

SPACE-RAY
INFRARED GAS HEATERS



INSTALLATION AND OPERATION INSTRUCTIONS

OWNER / INSTALLER: For your safety this manual must be carefully and thoroughly read and understood before installing, operating or servicing this heater.

INFRARED RADIANT TUBE HEATER

Single Stage Push Through System (Positive Pressure)

Models:

PTS SERIES: (40, 50, 75, 100, 125, 150, 175, 200) – N5/L5

PTU SERIES: (40, 50, 75, 100, 125, 150, 175, 200) – N5/L5

INSTALLER: This manual is the property of the owner. Please present this manual to the owner when you leave the job site.

▲ WARNING: Improper installation, adjustment, alteration, service, or maintenance can cause property damage, injury or death. Read the installation, operation and maintenance instructions thoroughly before installing or servicing this equipment.

IF YOU SMELL GAS:

DO NOT try to light any appliance.
DO NOT touch any electrical switch; **DO NOT** use any telephone in your building.
IMMEDIATELY call your gas supplier from a neighbor's telephone. Follow the gas supplier's instructions. If you cannot reach your gas supplier, call the fire department.

FOR YOUR SAFETY

DO NOT store or use gasoline or other flammable vapors and liquids in the vicinity of this or any other appliance.

!IMPORTANT: SAVE THIS MANUAL FOR FUTURE REFERENCE.

SPACE-RAY

Post Office Box 36485 (28236) • 305 Doggett Street (28203) • Charlotte, North Carolina
Phone (704) 372-3485 • Fax (704) 332-5843 • www.spaceray.com • email: info@spaceray.com

TABLE OF CONTENTS

<u>SECTION</u>	<u>DESCRIPTION</u>	<u>PAGE</u>
1.0)	Safety.....	2
2.0)	Installer Responsibility.....	2
3.0)	General Information.....	2
4.0)	Minimum Clearances to Combustibles.....	4
5.0)	Specifications.....	5
6.0)	Packing List.....	5
6.1)	Accessory Packages.....	9
7.0)	Typical Layouts - PTS/U Series.....	11
7.1)	Typical Assembly Layout.....	12
8.0)	Dimensions - PTS Series.....	13
8.1)	Dimensions - PTU Series.....	14
8.2)	Heater Assembly / Joining of Tube Sections.....	15
9.0)	Typical Suspension Methods.....	17
10.0)	Assembly of Tube Sections.....	18
10.1)	Assembly of Extension Section.....	19
10.2)	Inserting Turbulators.....	20
10.3)	Adding Body Reflectors.....	21
11.0)	Adding Optional 90° Elbow (PTS Only).....	22
11.1)	Adding Optional Corner Reflector (PTS Only).....	22
11.2)	Adding 180° U-Bend (PTU Only).....	23
11.3)	Adding Optional U-Bend Reflector (PTU Only).....	23
12.0)	Attaching Control Box Assembly.....	24
12.1)	Connecting The TISS System.....	25
13.0)	Gas Connections And Regulations.....	28
14.0)	Instructions For Pressure Test Gauge Connection.....	30
15.0)	Electrical Connections.....	31
16.0)	Venting.....	34
17.0)	Air For Combustion.....	38
17.1)	Direct Outside Air For Combustion.....	38
18.0)	Lighting and Shutdown Instructions.....	40
19.0)	Sequence of Operation.....	40
20.0)	Burner Component Location.....	41
21.0)	Cleaning And Annual Maintenance.....	42
22.0)	Troubleshooting Guide.....	43
23.0)	Replacing Parts.....	46
23.1)	Removal of Main Burner And Electrodes.....	46
23.2)	Removing Gas Valve And Manifold Assembly.....	47
23.3)	Air Switch Pressure Check.....	47
23.4)	Ignition System Checks.....	48
24.0)	Installation Data.....	49
25.0)	Replacement Parts Guide.....	50

This heater complies with ANSI Z83.20 (current standard) and CSA 2.34. Copies of the National Fuel Gas Code (ANSI Z223.1-latest edition) are available from the CSA at 8501 East Pleasant Valley Road, Cleveland, Ohio 44131 or 55 Scarsdale Road, Don Mills, Ontario M3B 2R3. All NFPA codes are available from the National Fire Protection Association, Batterymarch Park, Quincy, Massachusetts 02269.

1.0) SAFETY

This heater is a self-contained infrared radiant tube heater. Safety information required during installation and operation of this heater is provided in this manual and the labels on the product. The installation, service and maintenance of this heater must be performed by a contractor qualified in the installation and service of gas fired heating equipment.

All personnel in contact with the heater must read and understand all safety information, instructions and labels before operation. The following symbols will be used in this manual to indicate important safety information.

WARNING

Warning instructions must be followed to prevent or avoid hazards which may cause serious injury, property damage or death.

CAUTION

Caution instructions must be followed to prevent incorrect operation or installation of the heater which may cause minor injury or property damage.

2.0) INSTALLER RESPONSIBILITY

The installer is responsible for the following:

- The heater and venting, as well as electrical and gas supplies must be installed in accordance with these installation instructions and any applicable codes and regulations.
- Every heater shall be located with respect to building construction and other equipment so as to permit access to the heater.
- Each installer must follow the clearances to combustible materials for the heaters.
- Install the heater so that the supports and hangers are correctly spaced in accordance with these instructions. The heater must be supported by materials having a working load limit of at least 115lbs.
- Ensure that the tube integrity safety system TISS™ supplied is installed in accordance with these instructions and that the tension is correct.
- Supply the owner with a copy of these Installation and Operation Instructions.
- Where unvented heaters are used, gravity or mechanical means shall be provided to supply and exhaust at least 4 CFM per 1,000 Btu/hr input of installed heaters.
- Never use the heater as a support for a ladder or other access equipment. Do not hang anything from the heater.
- Supply all installation materials necessary that are not included with the heater.
- Check the nameplate to make sure that the burner is correct for the gas type in the building and the installation altitude.

3.0) GENERAL INFORMATION

This heater is a self-contained infrared radiant tube heater for use in locations where flammable gases or vapors are not generally present (as defined by OSHA acceptable limits) and is intended for the heating of **nonresidential** spaces.

INSTALLATION REQUIREMENTS

The installation must conform to local building codes or in the absence of local codes, with the National Fuel Gas Code ANSI Z223.1/NFPA54 or the Natural Gas and Propane Installation Code CSAB149.1. Heaters shall be installed by a licensed contractor or licensed installer. Clearances to combustibles as outlined in this manual should always be observed. In areas used for storage of combustible materials where they may be stacked below the heater, NFPA54 requires that the installer must post signs that will “specify the maximum permissible stacking height to maintain the required clearances from the heater to combustibles.”

Every heater shall be located with respect to building construction and other equipment so as to permit access to the

heater. Each installer shall use quality installation practices when locating the heater and must give consideration to clearances to combustible materials, vehicles parked below, lights, overhead doors, storage areas with stacked materials, sprinkler heads, gas and electrical lines and any other possible obstructions or hazards. Consideration also must be given to service accessibility.

The heater, when installed in aircraft hangars and public garages, must be installed in accordance with ANSI/NFPA 409-latest edition (Standard for Aircraft Hangars), ANSI/NFPA 88a-latest edition (Standard for Parking Structures), and ANSI/NFPA 88b-latest edition (Standard for Repair Garages) with the following clearances:

- a. At least 10 feet above the upper surfaces of wings or engine enclosures of the highest aircraft that may be housed in the hangar and at least 8 feet above the floor in shops, offices, and other sections of hangars communicating with aircraft storage or service areas.
- b. At least 8 feet above the floor in public garages. **▲WARNING:** Minimum clearances marked on the heater must be maintained from vehicles parked below the heater.

(FOR CANADA ONLY)

- a. Installation of this appliance is to be in accordance with latest edition of CAN 1-B149.1 (Installation Code for Natural Gas Burning Appliances and Equipment), and/or CAN B149.2 (Installation Code for Propane Gas Burning Appliances and Equipment).
- b. For installation in public garages or aircraft hangars, the minimum clearances from the bottom of the infrared heater to the upper surface of the highest aircraft or vehicle shall be 50 percent greater than the certified minimum clearance, but the clearance shall not be less than 8 feet.

Although these heaters may be used in many applications other than space heating (e.g., process heating), Space-Ray will not recognize the warranty for any use other than space heating.

This heater is for Indoor Installation and Covered Patio Installation only and can be used in either Vented or Unvented mode. The term Unvented actually means Indirect Vented. While the products of combustion are expelled into the building, national codes require ventilation in the building to dilute these products of combustion. This ventilation may be provided by gravity or mechanical means.

This heater is not an explosion proof heater. Where the possibility of exposure to volatile and low flash point materials exists, it could result in property damage or death. This heater must not be installed in a spray booth where the heater can operate during the spraying process. Consult your local fire marshal or insurance company.

PTS Series Only: Since straight tube heaters are always hotter at the control end than at the flue terminal end, always observe the minimum recommended mounting heights shown on the specification sheets and in Section 5.0 of this manual. Use U-tube configuration instead of straight tubes for spot or area heating (e.g., where a single heater is utilized for space heating).

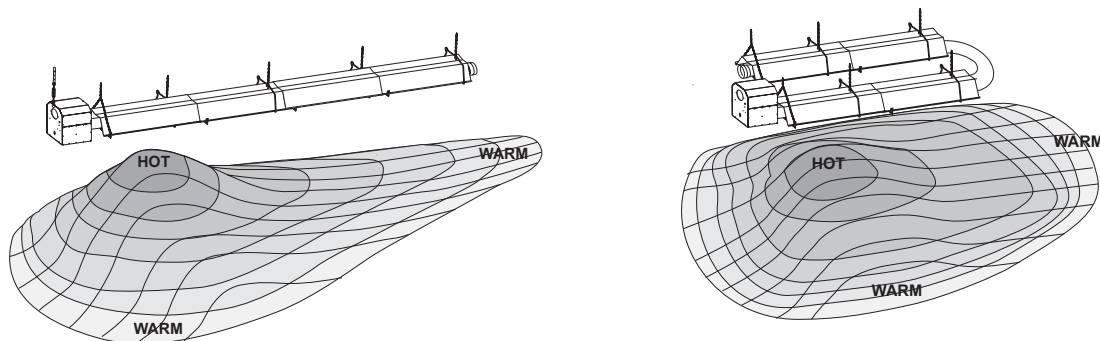

High Altitude:

Appliances are supplied as standard for altitudes of 0 to 2,000 feet (0-610 m). High-altitude ratings are obtained by a change in the orifice size. When ordered for high altitude installations, burners are supplied by the factory ready for high altitude installation. Check the nameplate for altitude before proceeding with the installation. In Canada the adjustment for altitude is made in accordance with Standard CGA 2.17, Gas-Fired Appliances for Use at High Altitudes.

4.0) MINIMUM CLEARANCES TO COMBUSTIBLES

⚠ WARNING		
		FIRE AND EXPLOSION HAZARD Combustible material must be located outside the clearance dimensions listed. Failure to do so may result in death, serious injury or property damage.

Minimum clearances to combustibles shall be measured from the outer surfaces as shown in the following diagram:

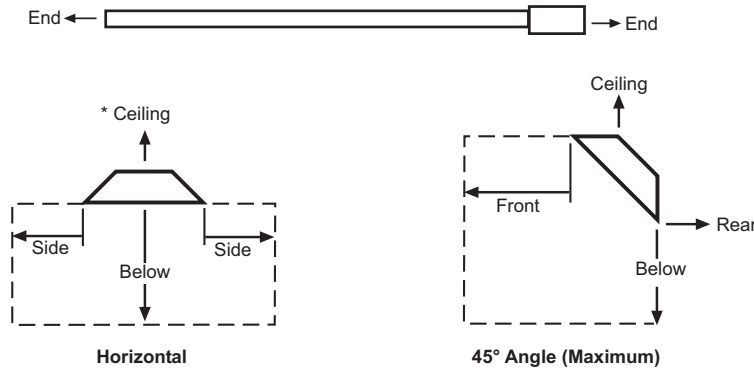

MINIMUM CLEARANCES TO COMBUSTIBLES						
Model No.	Mounted Horizontally				Angle Mounted at 45°	
	Sides	Ceiling*	Below	Ends	45° Front	45° Rear
PTS/PTU 40	27"	6"	40"	30"	48"	12"
PTS/PTU 50	27"	6"	40"	30"	48"	12"
PTS/PTU 75	27"	6"	60"	30"	48"	12"
PTS/PTU 100	66"	6"	88" **	40"	66"	20"
PTS/PTU 125	66"	6"	101" **	40"	66"	20"
PTS/PTU 150	84"	6"	106" **	48"	84"	24"
PTS/PTU 175	84"	6"	106" **	48"	84"	24"
PTS/PTU 200	84"	6"	106" **	48"	84"	24"

* When used indirect vented, minimum clearance for CEILING must be: 12" for PTS/PTU 50-75 and 18" for PTS/PTU 100-200. If optional corner and u-bend reflectors are not used, the clearance must be 18".

** Maximum clearance below reduces to 72" once you are 20ft. downstream from the control box.

▲WARNING: Certain materials or objects, when stored under the heater, will be subjected to radiant heat and could be seriously damaged. Observe the Minimum Clearances to Combustibles listed in the manual and on the heater at all times.

NOTE: The clearances specified above must be maintained to combustibles and other materials that may be damaged by temperatures 90°F above ambient temperature. Clearances to combustibles are posted on the control box. In areas used for storage of combustible materials where they may be stacked below the heater, NFPA54 requires that the installer must post signs that will "specify the maximum permissible stacking height to maintain the required clearances from the heater to combustibles." Space-Ray recommends posting these signs adjacent to the heater thermostat or other suitable location that will provide enhanced visibility.

BURNER PACKAGE NUMBERS:

NATURAL GAS	
<u>MODEL NO</u>	<u>PART NO.</u>
PTS/U 40-N5	#44149010
PTS/U 50-N5	#44149030
PTS/U 75-N5	#44149050
PTS/U 100-N5	#44149070
PTS/U 125-N5	#44149090
PTS/U 150-N5	#44149110
PTS/U 175-N5	#44149130
PTS/U 200-N5	#44149150

PROPANE GAS	
<u>MODEL NO</u>	<u>PART NO.</u>
PTS/U 40-L5	#44149020
PTS/U 50-L5	#44149040
PTS/U 75-L5	#44149060
PTS/U 100-L5	#44149080
PTS/U 125-L5	#44149100
PTS/U 150-L5	#44149120
PTS/U 175-L5	#44149140
PTS/U 200-L5	#44149160

B) PTS 40-200 Body Package Descriptions

(Package Part Number is indicated on the outside of each corresponding carton.)

System Lengths

PTS Body Packages – Aluminized/Hot Rolled or Alumi-Therm/Hot Rolled		10 Ft. 44134020	20 Ft. pkg 44135000	30 Ft. pkg 44136000	40 Ft. pkg 44137100	50 Ft. pkg 44138100
Part #	Each Body Package Includes:	Qty.	Qty.	Qty.	Qty.	Qty.
42912080	10 Ft. Tube with 24 Hole Flange (Aluminized)	1	1	1	-	-
42912169	10 Ft. Tube with 6 Hole Flange (Alumi-Therm)	-	-	-	1	1
41932101	10 Ft. Tube less Flanges (Hot Rolled)	-	1	2	3	4
43319100	Reflector, 9' 11½"	1	2	3	4	5
30462980	Tube Coupling	-	1	2	3	4
43318000	Tube Hanger/Support Bracket, 13"	1	2	3	4	5
43980010	Wire Hanger	1	2	3	4	5

Body Fastener Kit (included in body packages)		42907280	42907190	42907200	42907210	42907220
42873000	U-Bolt	1	2	3	4	5
02127110	Hex Nut, 5/16-18	3	5	6	8	10
02189020	HWHSM Screw, #10-16 x ½" TEKS	4	8	10	14	18

60Ft. System

PTS Body Packages – Alumi-Therm/Hot Rolled		40 Ft. Pkg 44137100	20 Ft. Pkg 44135010
Part #	Each Body Package Includes:	Qty.	Qty.
42912169	10 Ft. Tube with 6 Hole Flange (Alumi-Therm)	1	-
41932101	10 Ft. Tube less Flanges (Hot Rolled)	3	2
43319100	Reflector, 9' 11½"	4	2
30462980	Tube Coupling	3	2
43318000	Tube Hanger/Support Bracket, 13"	4	2
43980010	Wire Hanger	4	2

Body Fastener Kit (included in body packages)		42907210	42907190
42873000	U-Bolt	4	2
02127110	Hex Nut, 5/16-18	8	5
02189020	HWHSM Screw, #10-16 x ½" TEKS	14	8

70Ft. System

40 Ft. Pkg. 44137100	30 Ft. Pkg 44136040
Qty.	Qty.
1	-
3	3
4	3
3	3
4	3
4	3

42907210	42907200
4	3
8	6
14	10

C) PTS 40-200 Series Body Package Descriptions – ALC Option (Aluminized Calorized)

(Package Part Number is indicated on the outside of carton.)

System Lengths

PTS Body Packages – Aluminized/Aluminized or Alumi-Therm/Aluminized		10 Ft. Pkg 44134020	20 Ft. Pkg 44135020	30 Ft. Pkg 44136020	40 Ft. Pkg 44137090	50 Ft. Pkg 44138080
Part #	Each Body Package Includes:	Qty.	Qty.	Qty.	Qty.	Qty.
42912080	10 Ft. Tube with 24 Hole Flange (Aluminized)	1	1	1	-	-
42912169	10 Ft. Tube with 6 Hole Flange (Alumi-Therm)	-	-	-	1	1
41932100	10 Ft. Tube less Flanges (Aluminized)	-	1	2	3	4
43319100	Reflector, 9' 11½"	1	2	3	4	5
30462980	Tube Coupling	-	1	2	3	4
43318000	Tube Hanger/Support Bracket, 13"	1	2	3	4	5
43980010	Wire Hanger	1	2	3	4	5

Body Fastener Kit (included in body packages)		42907280	42907190	42907200	42907210	42907220
42873000	U-Bolt	1	2	3	4	5
02127110	Hex Nut, 5/16-18	3	5	6	8	10
02189020	HWHSM Screw, #10-16 x ½" TEKS	4	8	10	14	18

60Ft. System

PTS Body Packages – Alumi-Therm/Aluminized		40 Ft. Pkg 44137090	20 Ft. Pkg 44135030
Part #	Each Body Package Includes:	Qty.	Qty.
42912169	10 Ft. Tube with 6 Hole Flange (Alumi-Therm)	1	-
41932100	10 Ft. Tube less Flanges (Aluminized)	3	2
43319100	Reflector, 9' 11½"	4	2
30462980	Tube Coupling	3	1
43318000	Tube Hanger/Support Bracket, 13"	4	2
43980010	Wire Hanger	4	2

70Ft. System

40 Ft. Pkg 44137090	30 Ft. Pkg 44136050
Qty.	Qty.
1	-
3	3
4	3
3	3
4	3
4	3

Body Fastener Kit (included in body packages)		42907210	42907190
42873000	U-Bolt	4	2
02127110	Hex Nut, 5/16-18	8	5
02189020	HWHSM Screw, #10-16 x ½" TEKS	14	8

42907210	42907200
4	3
8	6
14	10

D) PTU 40-200 Body Package Descriptions

(Package Part Number is indicated on the outside of each corresponding carton.)

System Lengths

PTU Body Packages – Aluminized/Hot Rolled or Alumi-Therm/Hot Rolled		20 Ft. Pkg. 44135000	30 Ft. Pkg 44136010	40 Ft. Pkg 44137100	50 Ft. Pkg 44138110
Part #	Each Body Package Includes:	Qty.	Qty.	Qty.	Qty.
42912080	10 Ft. Tube with 24 Hole Flange (Aluminized)	1	1	-	-
42912169	10 Ft. Tube with 6 Hole Flange (Alumi-Therm)	-	-	1	1
41932101	10 Ft. Tube less Flanges (Hot Rolled)	1	1	3	3
41932051	5 Ft. Tube less Flanges (Hot Rolled)	-	2	-	2
43319100	Reflector, 9' 11½"	2	2	4	4
43319050	Reflector, 4' 11 ½"	-	2	-	2
30462980	Tube Coupling	1	3	3	5
43318000	Tube Hanger/Support Bracket, 13"	2	4	4	6
43980010	Wire Hanger	2	4	4	6

Body Fastener Kit (included in body packages)		42907190	42907210	42907210	42907221
42873000	U-Bolt	2	4	4	6
02127110	Hex Nut, 5/16-18	5	8	8	13
02189020	HWHSM Screw, #10-16 x 1/2" TEKS	8	14	14	24

U-Bend Package		43208020	43208020	43208020	43208020
42873000	U-Bend	1	1	1	1
43318500	31" Tube Support/Hanger Bracket	1	1	1	1
30462980	Tube Coupling	1	1	1	1
02189020	HWHSM Screw, #10-16 x 1/2" TEKS	2	2	2	2

60Ft. System

70Ft. System

PTU Body Packages – Alumi-Therm/Hot Rolled		40 Ft. Pkg. 44137100	20 Ft. Pkg. 44135010
Part #	Each Body Package Includes:	Qty.	Qty.
42912169	10 Ft. Tube with 6 Hole Flange (Alumi-Therm)	1	-
41932101	10 Ft. Tube less Flanges (Hot Rolled)	3	2
41932051	5 Ft. Tube less Flanges (Hot Rolled)	-	-
43319100	Reflector, 9' 11 1/2"	4	2
43319050	Reflector, 4' 11 1/2"	-	-
30462980	Tube Coupling	3	2
43318000	Tube Hanger/Support Bracket, 13"	4	2
43980010	Wire Hanger	4	2

40 Ft. Pkg. 44137120	30 Ft. Pkg. 44136040
Qty.	Qty.
1	-
2	3
2	-
3	3
2	-
4	3
5	3
5	3

Body Fastener Kit (included in body packages)		42907210	42907219
42873000	U-Bolt	4	2
02127110	Hex Nut, 5/16-18	8	5
02189020	HWHSM Screw, #10-16 x 1/2" TEKS	14	8

42907220	42907200
5	3
10	6
18	10

U-Bend Package		43208020
42873000	U-Bend	1
43318500	31" Tube Support/Hanger Bracket	1
30462980	Tube Coupling	1
02189020	HWHSM Screw, #10-16 x 1/2" TEKS	2

43208020
1
1
1
2

E) PTU 40-200 Series Body Package Descriptions – ALC Option (Aluminized Calorized)

(Package Part Number is indicated on the outside of each corresponding carton.)

System Lengths

PTU Body Packages –Aluminized/Aluminized or Alumi-Therm/Aluminized		20 Ft. Pkg. 44135020	30 Ft. Pkg. 44136030	40 Ft. Pkg. 44137090	50 Ft. Pkg. 44138090
Part #	Each Body Package Includes:	Qty.	Qty.	Qty.	Qty.
42912080	10 Ft. Tube with 24 Hole Flange (Aluminized)	1	1	-	-
42912169	10 Ft. Tube with 6 Hole Flange (Alumi-Therm)	-	-	1	1
41932100	10 Ft. Tube less Flanges (Aluminized)	1	1	3	3
41932050	5 Ft. Tube less Flanges (Aluminized)	-	2	-	2
43319100	Reflector, 9' 11 1/2"	2	2	4	4
43319050	Reflector, 4' 11 1/2"	-	2	-	2
30462980	Tube Coupling	1	3	3	5
43318000	Tube Hanger/Support Bracket, 13"	2	4	4	6
43980010	Wire Hanger	2	4	4	6

Body Fastener Kit (included in body packages)		42907190	42907210	42907210	42907221
42873000	U-Bolt	2	4	4	6
02127110	Hex Nut, 5/16-18	5	8	8	13
02189020	HWHSM Screw, #10-16 x 1/2" TEKS	8	14	14	24

U-Bend Package		43208020	43208020	43208020	43208020
42873000	U-Bend	1	1	1	1
43318500	31" Tube Support/Hanger Bracket	1	1	1	1
30462980	Tube Coupling	1	1	1	1
02189020	HWHSM Screw, #10-16 x 1/2" TEKS	2	2	2	2

		60Ft. System		70Ft. System	
PTU Body Packages – Alumi-Therm/Aluminized		40 Ft. Pkg. 44137090	20 Ft. Pkg. 44135030	40 Ft. Pkg. 44137110	30 Ft. Pkg. 44136050
Part #	Each Body Package Includes:	Qty.	Qty.	Qty.	Qty.
42912169	10 Ft. Tube with 6 Hole Flange (Alumi-Therm)	1	-	1	-
41932100	10 Ft. Tube less Flanges (Aluminized)	3	2	2	3
41932050	5 Ft. Tube less Flanges (Aluminized)	-	-	2	-
43319100	Reflector, 9' 11 1/2"	4	2	3	3
43319050	Reflector, 4' 11 1/2'	-	-	2	-
30462980	Tube Coupling	3	2	4	3
43318000	Tube Hanger/Support Bracket, 13"	4	2	5	3
43980010	Wire Hanger	4	2	5	3

Body Fastener Kit (included in body packages)		42907210	42907219	42907220	42907200
42873000	U-Bolt	4	2	5	3
02127110	Hex Nut, 5/16-18	8	5	10	6
02189020	HWHSM Screw, #10-16 x 1/2" TEKS	14	8	18	10

U-Bend Package		43208020	43208020
42873000	U-Bend	1	1
43318500	31" Tube Support/Hanger Bracket	1	1
30462980	Tube Coupling	1	1
02189020	HWHSM Screw, #10-16 x 1/2" TEKS	2	2

6.1) ACCESSORIES

A) End Reflector Accessory Package, Part #43341010

(1 pkg. per PTS Series or 2 pkgs. per PTU Series)

Contains:

End Reflector, #43320000.....QTY-2

Speed Clips, #02266010.....QTY-4

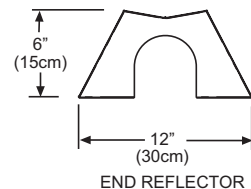

END REFLECTOR

B) Elbow Accessory Package, Part #43208010

(Option for PTS Series Only)

Contains:

Elbow, #431750010.....QTY-1

#10-16 x 1/2 Self-Drilling Screws, #02189020.....QTY-2

Tube Coupling, #30462980.....QTY-1

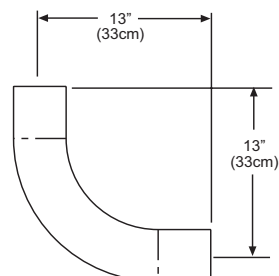

C) Corner Reflector Accessory Package, Part #43342000

(Option for PTS Series Only)

Contains:

Corner Reflector Assembly, #43345000.....QTY-1

Speed Clips, #02266010.....QTY-4

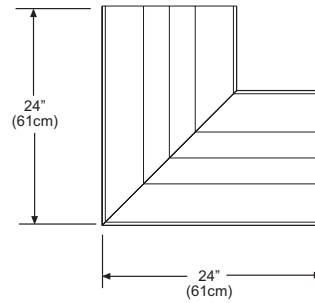

D) U-Bend Package, Part #43208020

(Option for PTU Series Only)

Contains:

U-Bend, #42913020.....QTY-1

#10-16 x 1/2 Self-Drilling Screws, #02189020.....QTY-2

Tube Coupling, #30462980.....QTY-1

31" Hanger/Tube Support, #43318500.....QTY-1

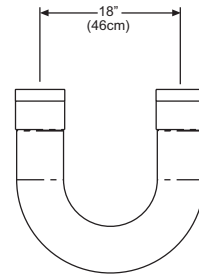

E) U-Bend Reflector Package, Part #43488000

(Option for PTU Series Only)

Contains:

U-Bend Reflector, #43490000.....QTY-1

U-Bend End Reflector, #43490050.....QTY-1

Speed Clips, #02266010.....QTY-11

#10-16 x 1/2 Self-Drilling Screws, #02189020.....QTY-4

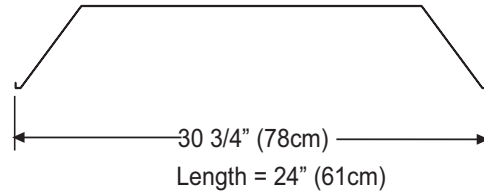

F) 31" Hanger/Tube Support, Part #43318500

(Option for Angle Mounting of PTU Series)

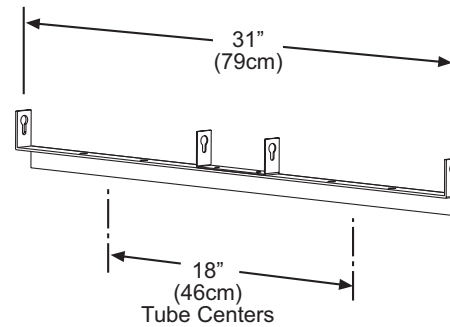

G) Exhaust Hood Package, Part #42924000

Contains:

Exhaust Hood Assembly, #42925540.....QTY-1

#10-16 x 1/2 Self-Drilling Screws, #02189020.....QTY-2

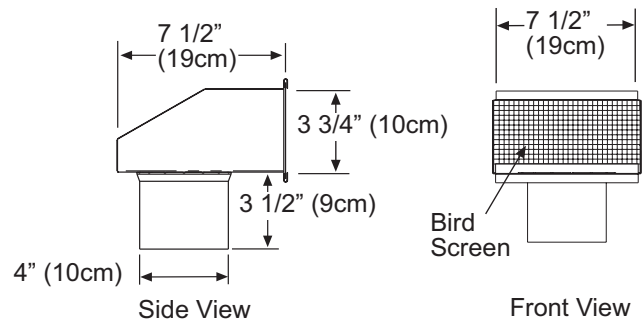

7.0) TYPICAL LAYOUTS – PTU / PTS Series

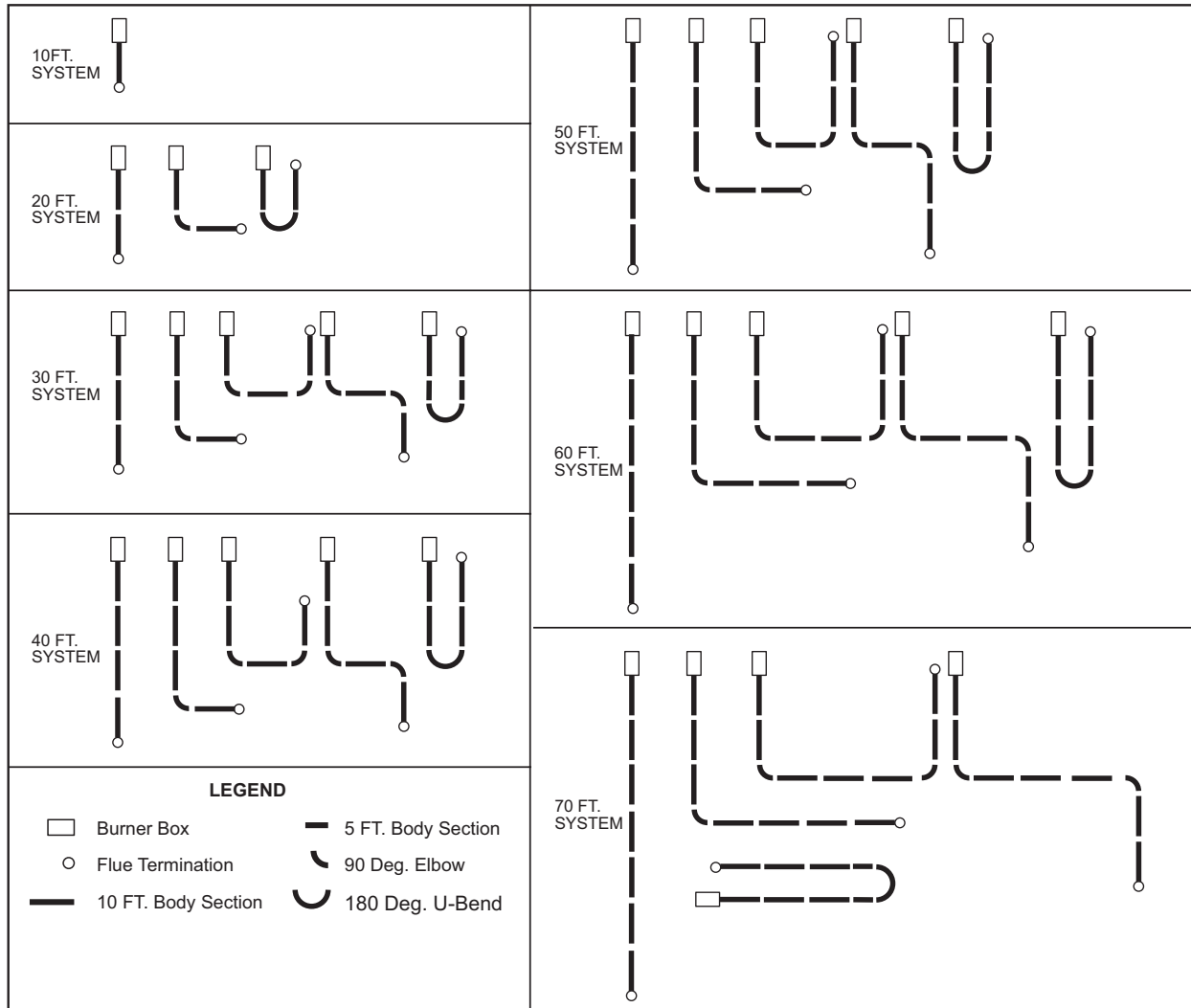

MODEL	EMITTER LENGTH		MODEL	BODY LENGTH	
	Min.	Max.		Min.	Max.
PTS 40	10 Ft.	20 Ft.	PTU 40	10 Ft.	10 Ft.
PTS 50	20 Ft.	30 Ft.	PTU 50	10 Ft.	15 Ft.
PTS 75	20 Ft.	30 Ft.	PTU 75	10 Ft.	15 Ft.
PTS 100	30 Ft.	40 Ft.	PTU 100	15 Ft.	20 Ft.
PTS 125	30 Ft.	50 Ft.	PTU 125	15 Ft.	25 Ft.
PTS 150	40 Ft.	60 Ft.	PTU 150	20 Ft.	30 Ft.
PTS 175	50 Ft.	70 Ft.	PTU 175	25 Ft.	35 Ft.
PTS 200	50 Ft.	70 Ft.	PTU 200	25 Ft.	35 Ft.

NOTES:

- 1) In all configurations, the control unit must be connected directly to either a) the 24-hole flange of the 10 ft. aluminized steel starting body section (for 10 ft., 20 ft., and 30 ft. systems) or b) the 6-hole flange of the 10 ft. alumi-therm steel starting body section (for 40 ft., 50 ft., 60 ft., and 70 ft. systems).
- 2) Joining of two 90° elbows directly together to form a "Z" shape IS NOT permitted.
- 3) PTS / U 175 - 40 ft length available for special applications.
- 4) 5 Ft. Body Packages may be utilized on any of these heaters to yield heater lengths from 15 ft. to 70 ft.
- 5) Any configuration of components not shown in the illustrations may be used except as noted in 1 and 2

above.

7.1) TYPICAL ASSEMBLY LAYOUT

⚠ WARNING

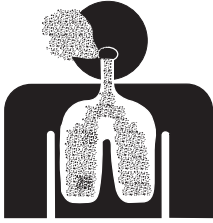

POISONOUS GAS AND SOOT HAZARD

The heater must be assembled with the correct number of turbulator sections and tube length for the rated heat input.

The turbulator must be installed in the last tube section as shown.

Failure to do so may result in death, serious injury, property damage or illness from Carbon Monoxide poisoning.

10 FT. SYSTEM

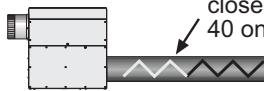

Stainless Steel Turbulator
closest to burner PTS / U
40 only.

20 FT. SYSTEM



30 FT. SYSTEM



40 FT. SYSTEM



50 FT. SYSTEM



60 FT. SYSTEM



70 FT. SYSTEM



MODEL	2 Ft. Turbulator Sections
PTS/U 40	4
PTS/U 50	5
PTS/U 75	5
PTS/U 100	3
PTS/U 125	7
PTS/U 150	4
PTS/U 175	0
PTS/U 200	1

LEGEND

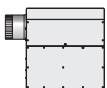

Burner Box



10ft Aluminized Tube 24
Hole Flange
or
10ft Alumi-Therm Tube
6 Hole Flange



Coupling



10ft Aluminized or HRS
Tube model dependent



2ft Stainless
Steel
Turbulator
sections



2ft Aluminized
Steel
Turbulator
sections

8.0) DIMENSIONS - PTS Series

Typical Dimensions Up to 60 Ft. Shown.

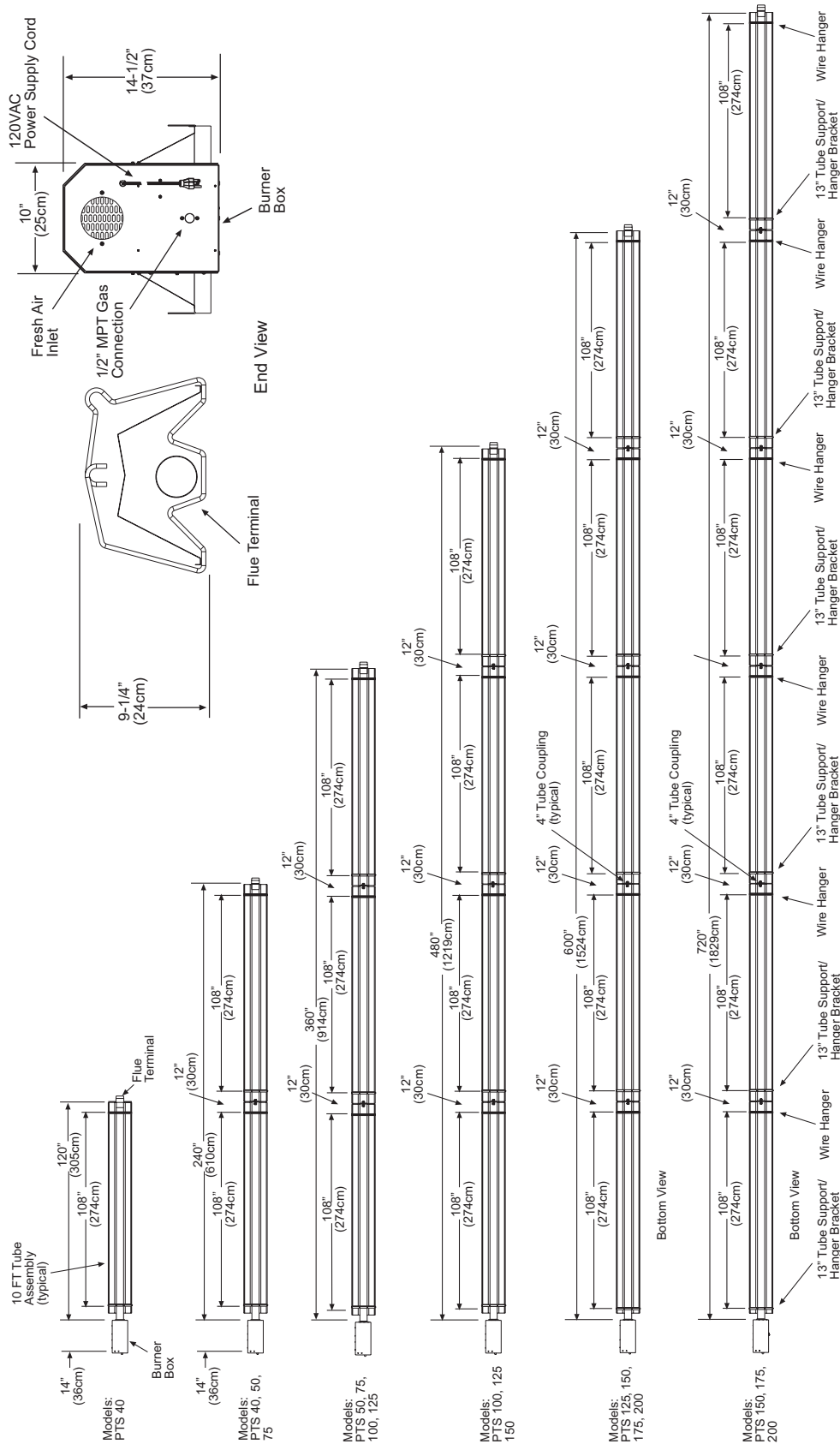

8.1) DIMENSIONS - PTU Series

Typical Dimensions Up to 50 Ft. Shown.

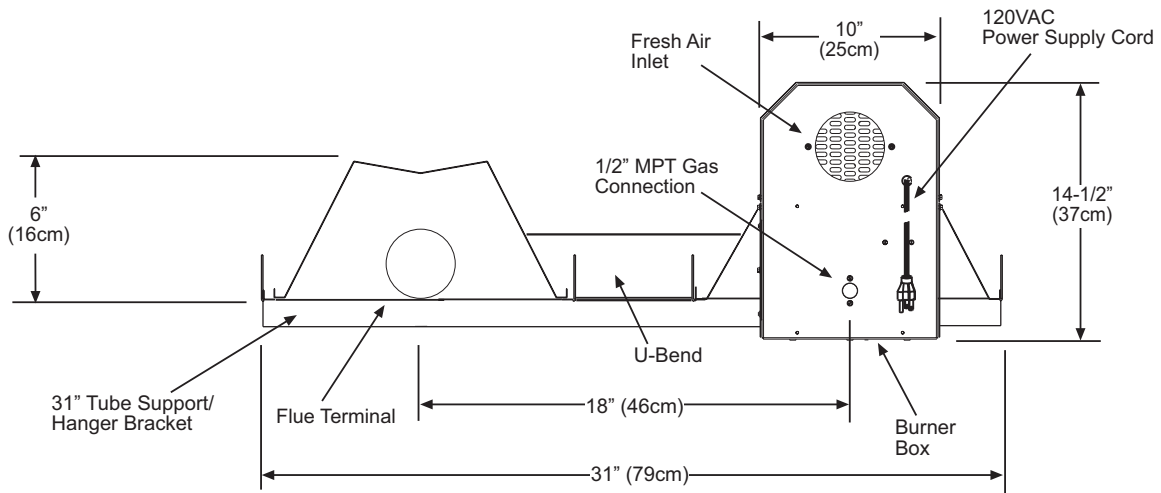
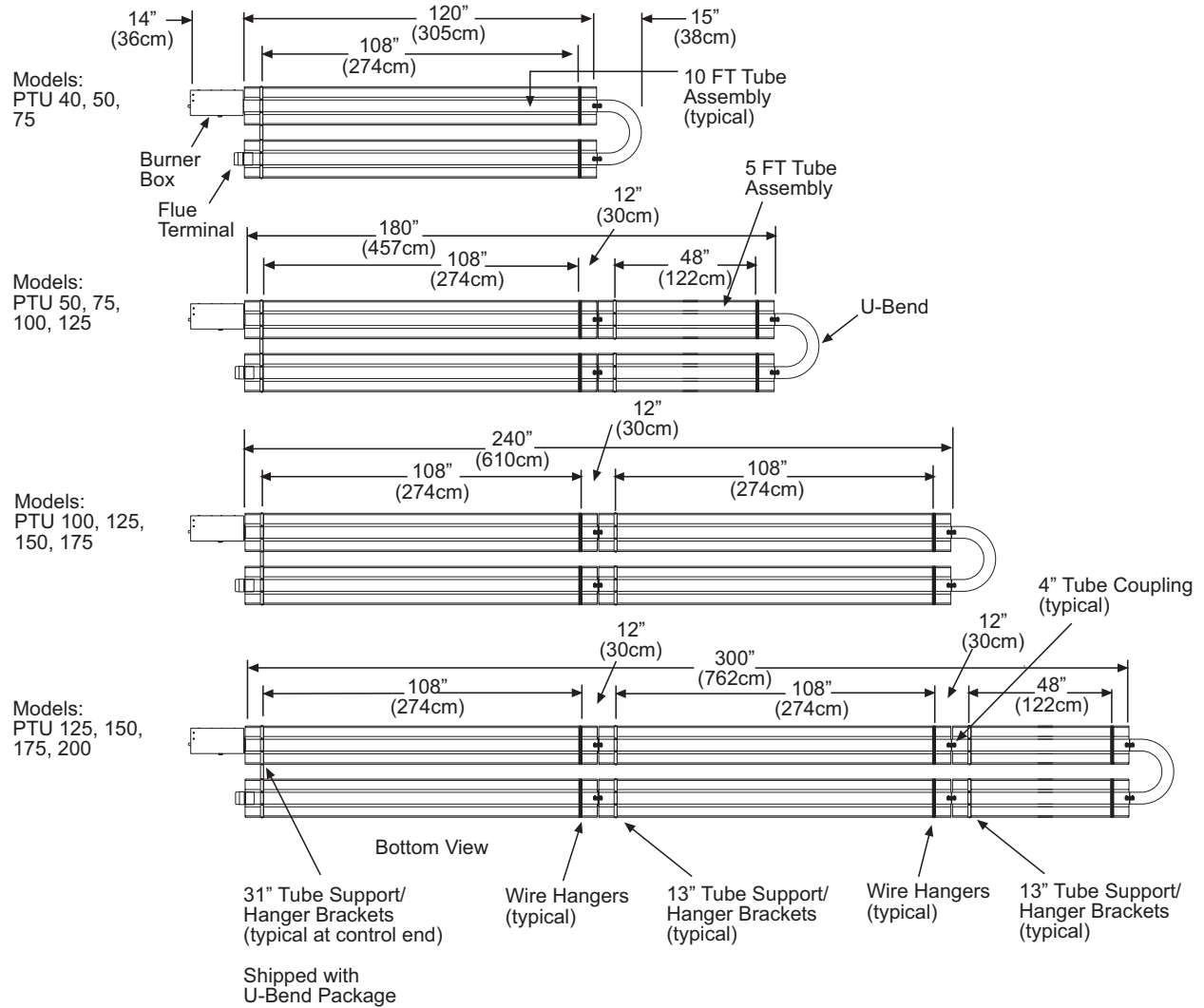

PTU (end view)

8.2) HEATER ASSEMBLY / JOINING OF TUBE SECTIONS

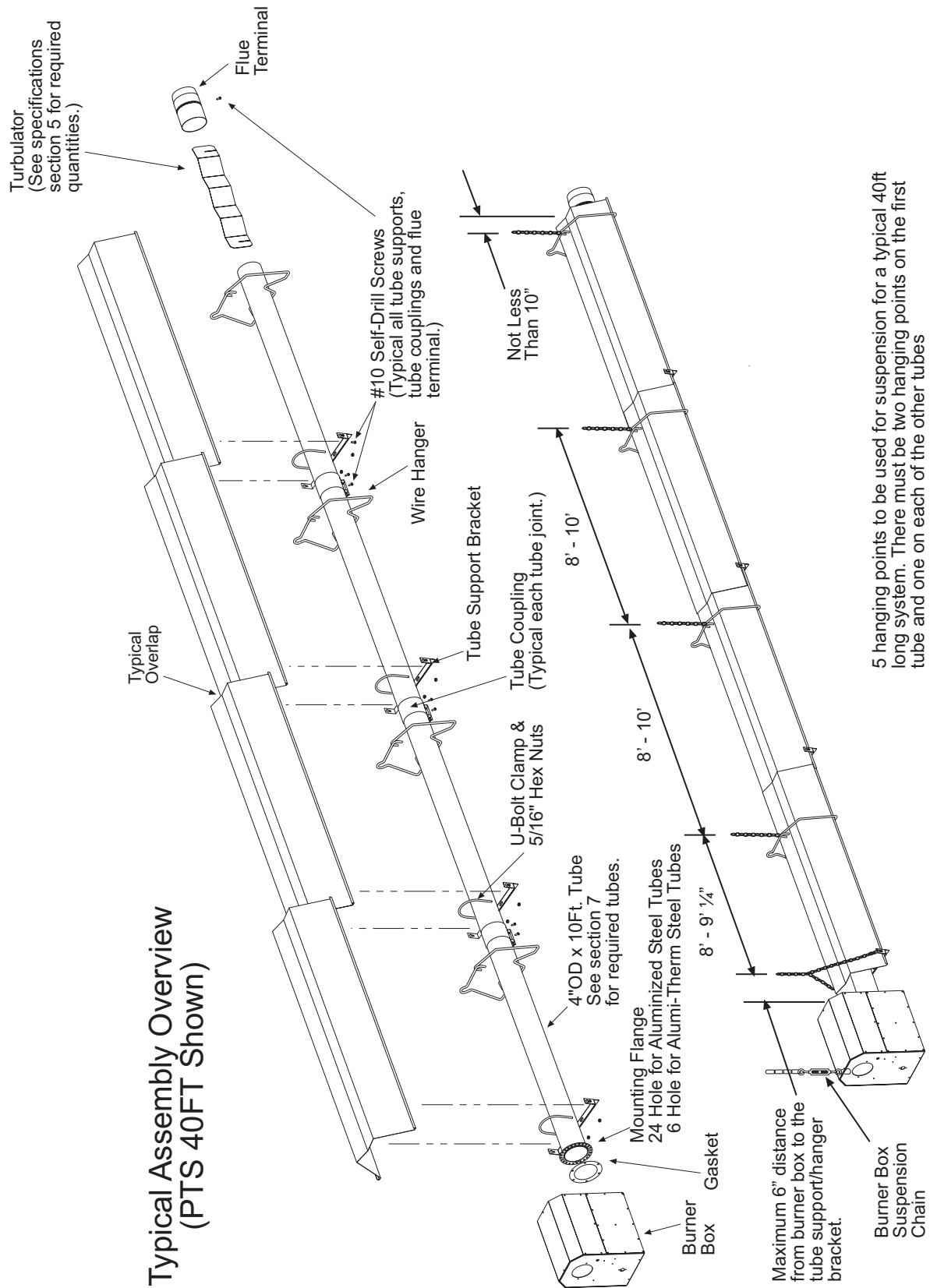

5 hanging points to be used for suspension for a typical 40ft long system. There must be two hanging points on the first tube and one on each of the other tubes

Typical Assembly Overview (PTU 40FT Shown)

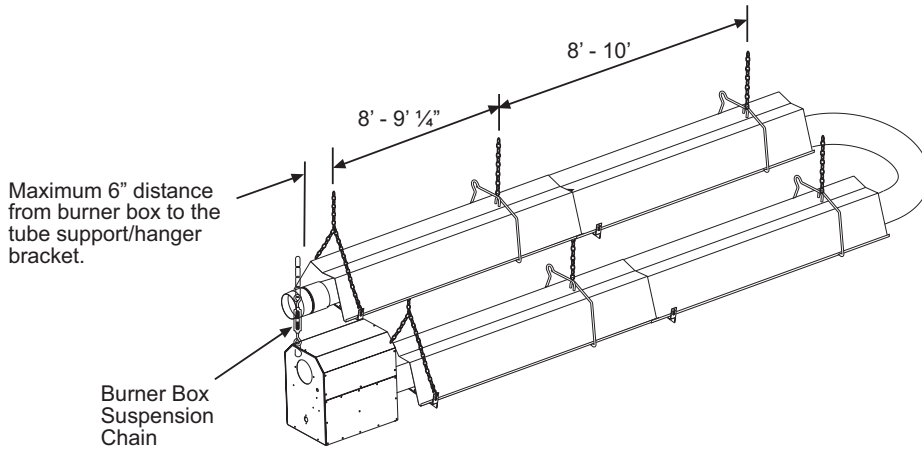
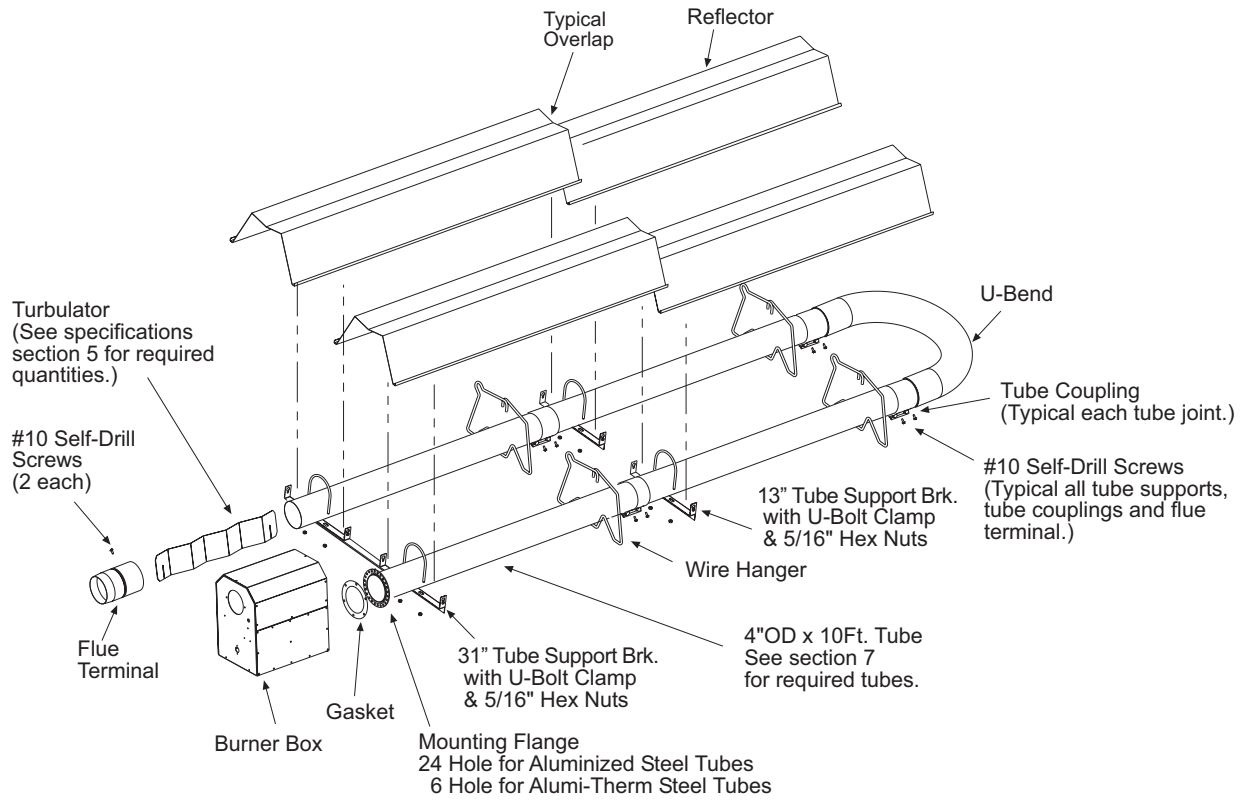

6 hanging points to be used for suspension for a typical 40ft long system. There must be two hanging points on the first tube and one on each of the other tubes

9.0) TYPICAL SUSPENSION METHODS

⚠ WARNING



SUSPENSION HAZARD

Burner must be secured to the mounting flange with nuts.

All materials used to suspend the heater must have a minimum working load of 115 lbs.

All "S" Hooks must be crimped closed.

Never use the heater to support a ladder or other access equipment.

Failure to do so may result in death, serious injury or property damage.

Various means of suspending the heater can be used. See the following drawings for typical examples.

1. Use only noncombustible materials for hangers and brackets.
2. A minimum No. 2 chain with a working load limit of 115 lbs. is required.
3. Turnbuckles can be used with chains to allow leveling of the heater. All "S" hooks and eye bolts must be manually crimped closed by the installer.
4. When using rigid means for heater suspension (rod, flat bar, etc.) provide sufficient lengths or swing joints to compensate for expansion. See Figures b and c.
5. Heaters subject to vibration must be provided with vibration isolating hangers.
6. Heaters must not be supported by gas or electric supply lines and must be suspended from a permanent structure with adequate load capacity.

Space-Ray recommends that the body sections be suspended using chains with turnbuckles. This will allow slight adjustments after assembly and heater expansion/ contraction during operation.

If a "trapeze" method is used (shown below), the minimum chain length for the two connecting chains is 36". If these chains must be less than 36", then do not use the trapeze method and, instead, use individual chains on each tube support/hanger bracket.

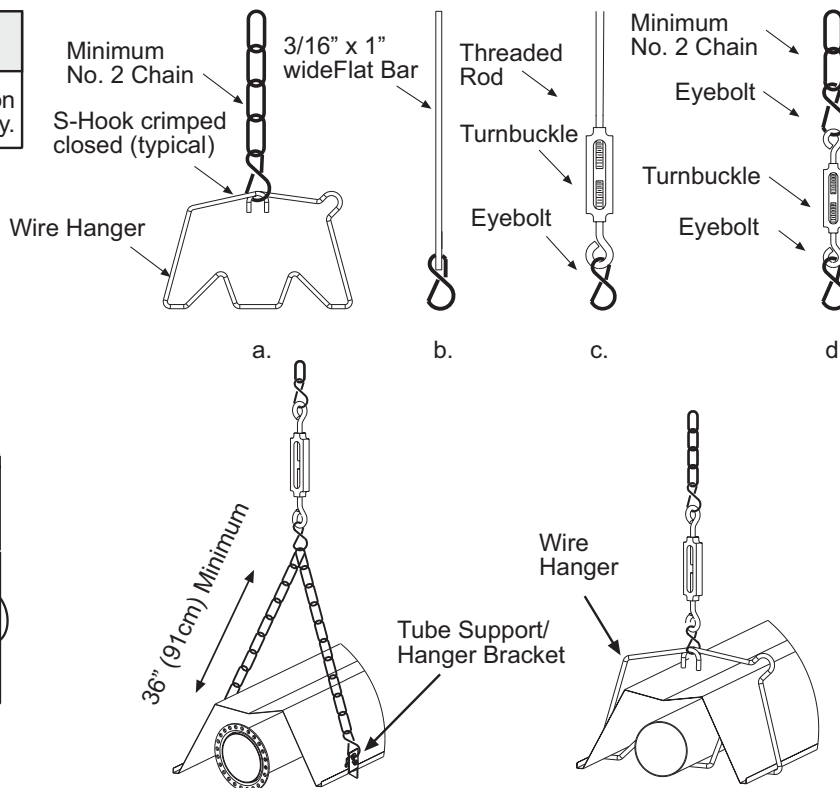
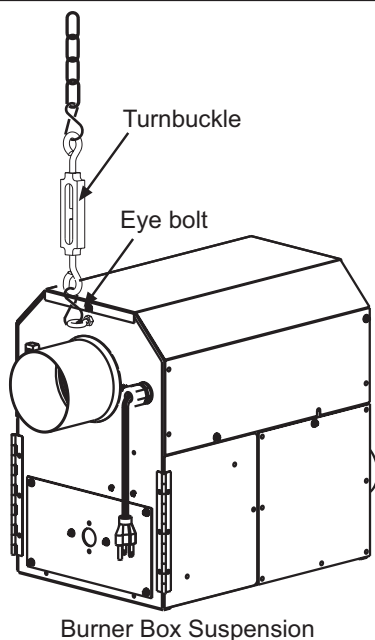

10.0) ASSEMBLY OF TUBE SECTIONS

! CAUTION	
	CUT HAZARD
Sheet metal parts, particularly reflectors and vent have sharp edges. Always use gloves when handling.	
Failure to do so may result in death, serious injury or property damage.	

During field assembly of the heater body sections, the recommended procedure is as follows:

1. Before hanging heater sections, first determine the actual layout of the system (see Sections 7.0 & 8.0 for details). Consideration must also be taken for flue pipe, fresh air ducting, gas piping, clearances to combustibles, etc. before hanging heater. Typical suspension methods are shown in Section 9.0.
2. Hang each tube section individually. **DO NOT** attach the heater tube sections together on the ground and attempt to hang the entire system.
3. In all configurations, the burner box must be connected directly to either **a**) the 24-hole flange of the 10 ft. aluminized steel starting body section (for 10 ft., 20 ft., and 30 ft. systems) **or b**) the 6-hole flange of the 10 ft. alumi-therm steel starting body section (for 40 ft., 50 ft., 60 ft., and 70 ft. systems).
4. Assemble a tube support/hanger bracket 4" from the end of the heat exchanger tube having the mounting flange. Align the tube such that the welded seam is facing down toward the ground.

! CAUTION FAILURE TO ASSEMBLE THE TUBE WITH THE SEAM FACING DOWN WILL VOID THE MANUFACTURER'S WARRANTY.

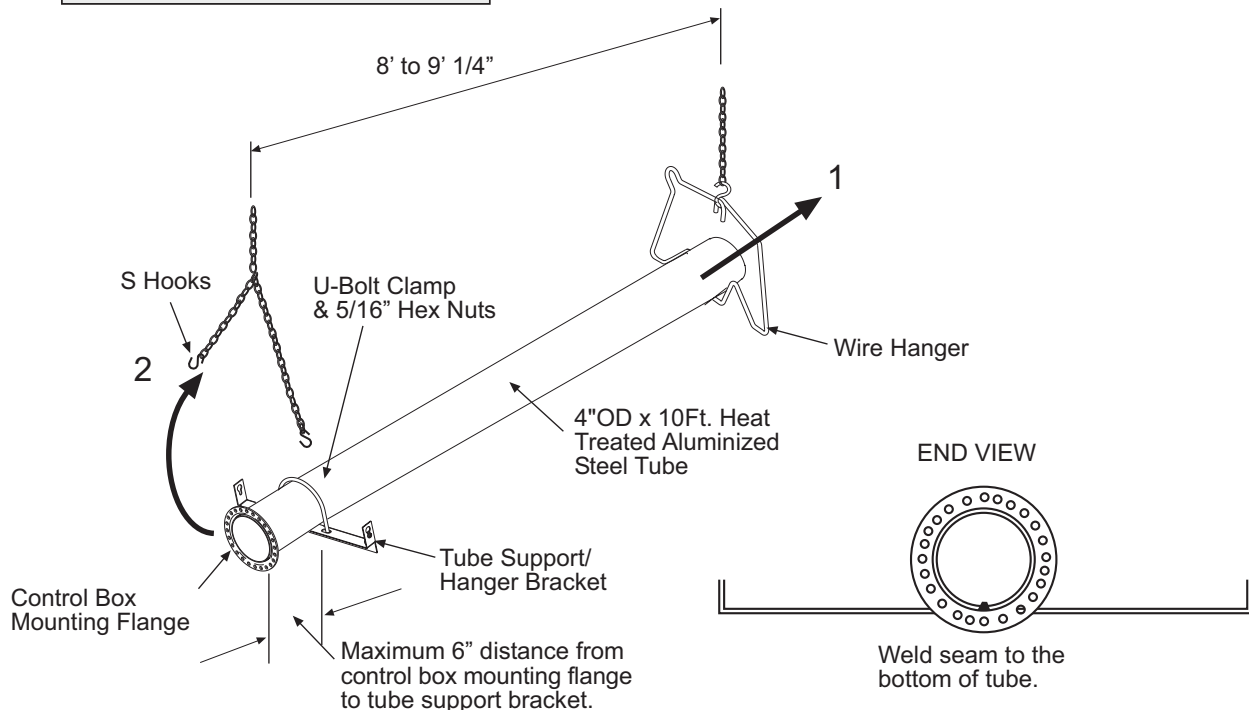

5. Suspend the chain to attach the wire hanger and the tube support bracket. Insert the tube into the wire hanger and then raise the tube support bracket end up to the suspension chain, use "S" hooks to attach the wire hanger and tube support bracket to the chain.

10.1 ASSEMBLY OF EXTENSION SECTION

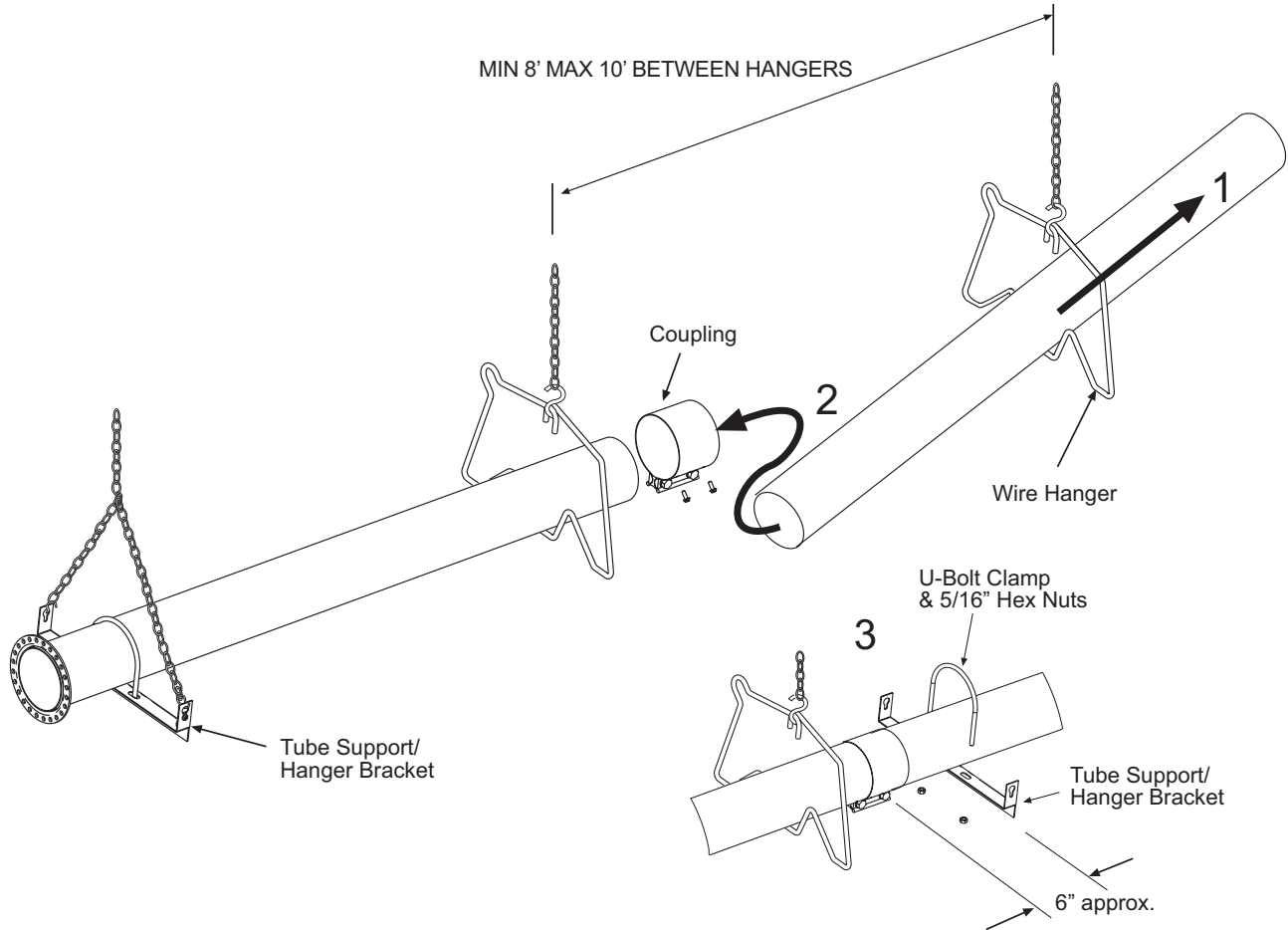

See typical assembly overview (Section 8.0) for typical complete assembly. Assemble additional extension sections as required for all systems. (See Sections 7.0, and 8.0 for typical layout details.)

Join the tube sections together and secure with tube couplings as described below:

▲WARNING: THE FOLLOWING COUPLING TIGHTENING INSTRUCTIONS MUST BE FOLLOWED PROPERLY TO AVOID FUTURE PROBLEMS.

1. Place the compression coupling over the end of the tube.
2. Use the small hole at the centerline of the coupling to check that the coupling is inserted correctly.
3. Partially tighten the bolt nearest the end of the tube (approximately half closed).

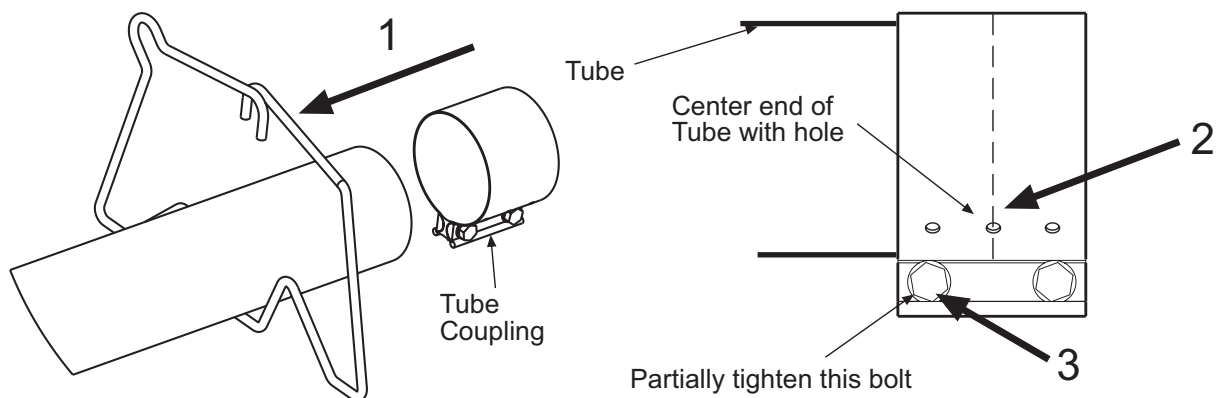

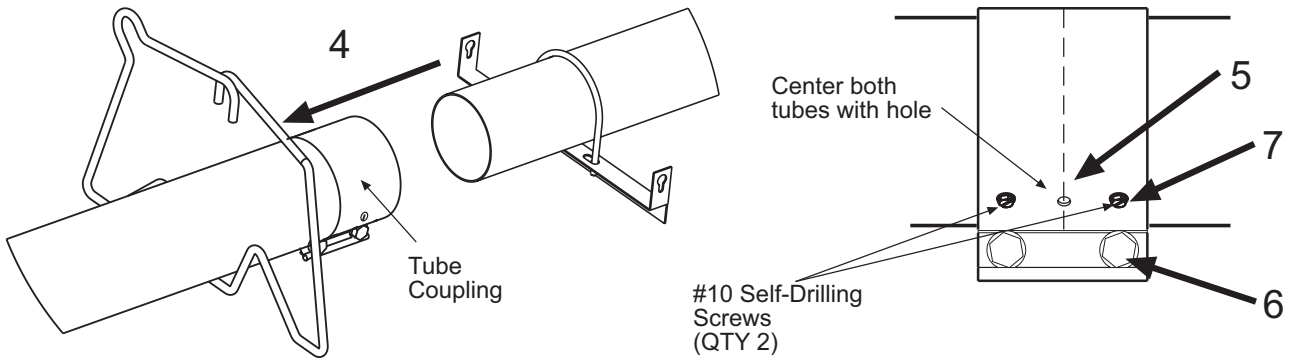

4. Slide the next tube into the coupling.
5. Make sure both tube ends are butted together.
6. Finish tightening both bolts to 40-60 ft.lbs. torque to ensure a complete seal.
7. Use the two Self-drilling screws through the pre-punched holes to secure the tubes in the coupling.

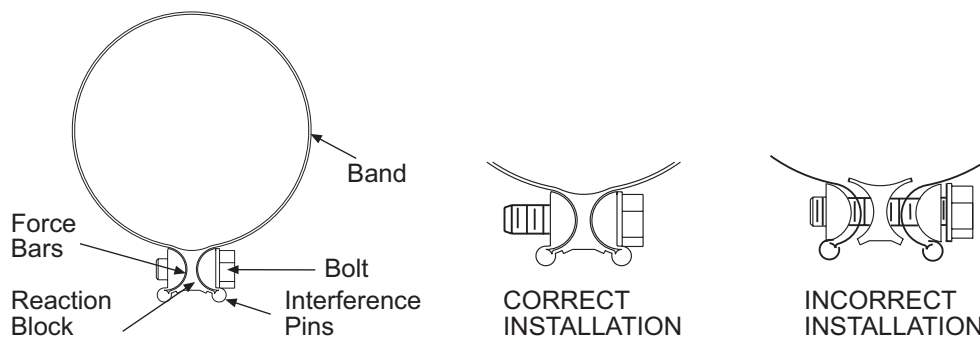

8. Check to ensure that the hardware is completely closed and the band is seated on the reaction block and interference pins as illustrated above.
9. Once all the heater body sections are attached, make sure that the heater system is level. If it is not, slight adjustments can be made using the turnbuckles. (See Section 9.0)



IMPORTANT: NEVER REUSE A COUPLING. Always install a new coupling only and torque as per instructions above and the diagrams above.

10.2) INSERTING TURBULATORS

⚠ WARNING

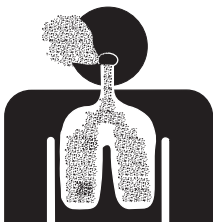

POISONOUS GAS AND SOOT HAZARD

The heater must be assembled with the correct number of turbulator sections and tube length for the rated heat input.

The turbulator must be installed in the last tube section as shown.

Failure to do so may result in death, serious injury, property damage or illness from Carbon Monoxide poisoning.

1. Assemble the turbulators together by interlocking the slotted end portions. Slide these into the last tube section until they are flush with the tube end. Note: Refer to the table below for quantities of turbulators required for each heater model.

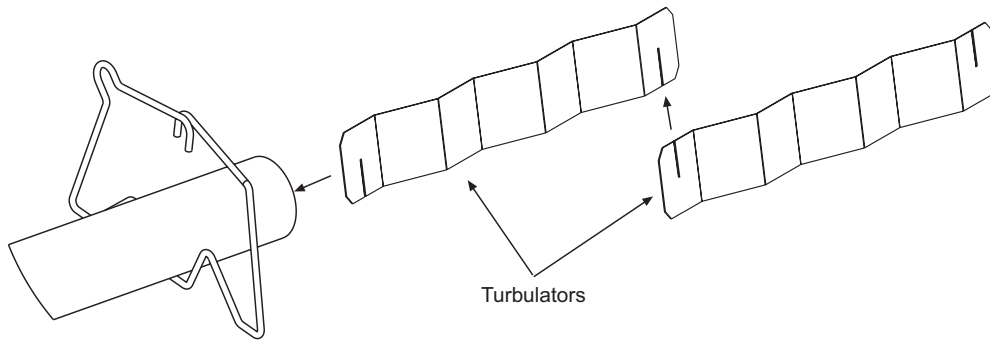

MODEL	2 Ft. Turbulator Sections
PTS/U 40	4
PTS/U 50	5
PTS/U 75	5
PTS/U 100	3
PTS/U 125	7
PTS/U 150	4
PTS/U 175	0
PTS/U 200	1

⚠ CAUTION

ASSEMBLY HAZARD

The PTS / U 40 has one stainless steel turbulator. This must be installed closest to the burner.

Failure to do so may result in deterioration of the turbulator material and invalidate the warranty.

10.3) ADDING REFLECTORS

- Slide the reflectors on the tube support/hanger brackets and through the wire hangers.
- The tube at the coupling joints must be covered. Slide the reflectors together and provide an overlap of two (2") inches for the first reflector overlap after the control unit. All remaining reflector overlaps will be approximately one (1") inch. This will allow for the natural expansion and contraction of the heater when in operation. **Note: The heaters can expand and contract up to 1-3/4" of an inch.**
- Secure the reflectors as shown in Detail "A" using #10 x 1/2" self-drilling sheet metal screws at each tube support/hanger bracket.

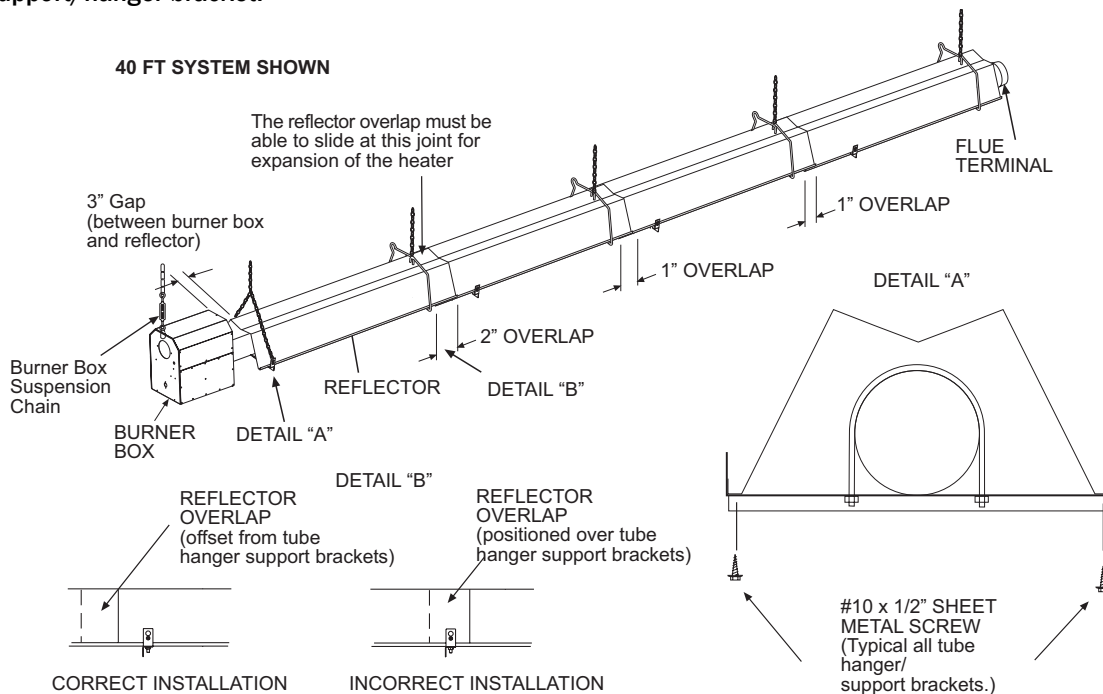

11.0) ADDING OPTIONAL 90° ELBOW (PTS ONLY)

1. The optional 90° elbow must be located a minimum of 10 ft. after the control box.
2. Hang the body sections in a 90° ("L") shaped pattern. Allow spacing for the elbow. The distance from one end of the elbow to the centerline of the opposite leg is 13" as shown.
3. Join the tube ends of the body sections and the elbow together and secure with tube couplings as described in Section 10.1.

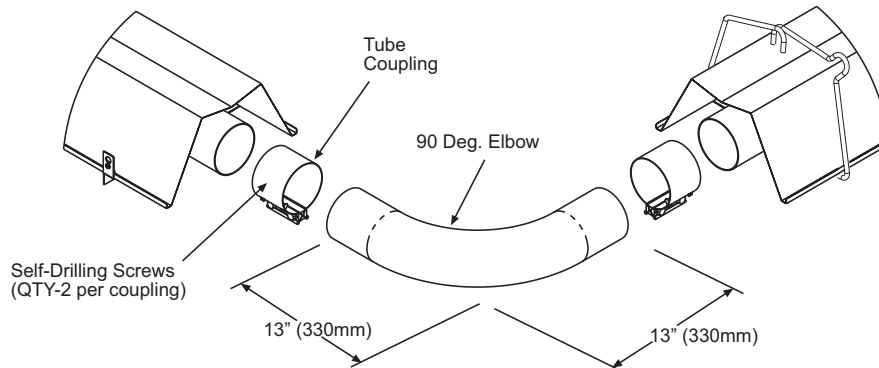

11.1) ADDING OPTIONAL CORNER REFLECTOR (PTS ONLY)

1. Place the corner reflector over the reflectors of both body sections.
2. Secure by sliding speed clips on the reflector edges. One speed clip is required for each side of reflector.
3. The corner reflector can be used only when the long axis of the heater is level and mounted in a horizontal position.

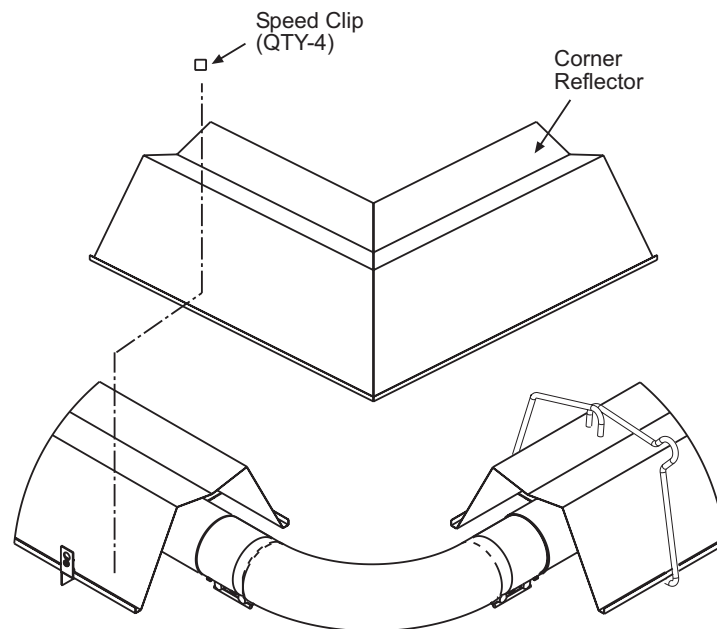

11.2) ADDING 180° U-Bend (PTU ONLY)

1. Hang body sections parallel with each other. The centerline distance from tube at each body section should be 18" as shown.
2. Join tube ends of body sections and the **U-Bend** together and secure with tube couplings as described in Section 10.1.

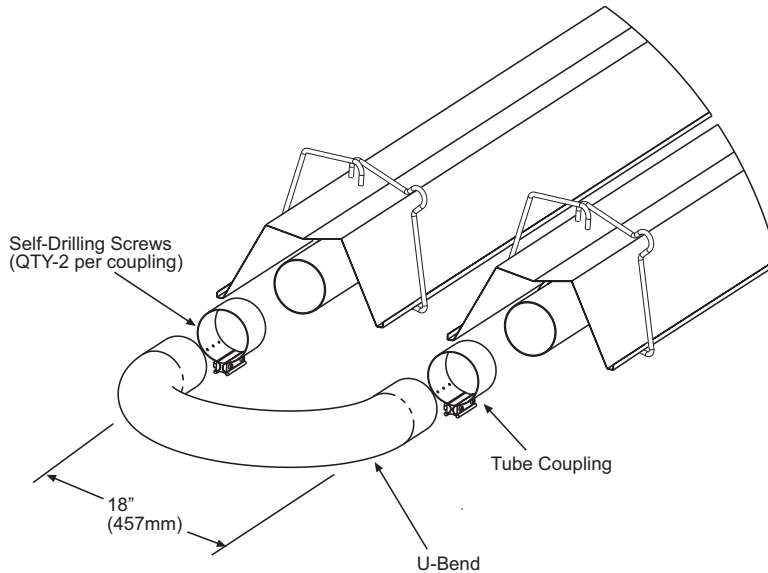

11.3) ADDING OPTIONAL U-BEND REFLECTOR (PTU ONLY)

1. Place the **U-Bend Reflector** over the reflectors of each body section with the end resting next to the tube wire hangers as shown.
2. Slide the speed clips on the reflector edges towards the end of the body section reflectors. Two speed clips are required for each side of the **U-Bend Reflector**. Make sure that the speed clips fit tightly over both the **U-Bend Reflector** and the reflector on each body section. Use two self-drilling screws to permanently secure both sides to the reflectors.
3. Place the **End Reflector** flush with the **U-Bend Reflector** as shown. **Note:** Clearance between end of the **U-Bend Reflector** and the **U-Bend** must be a minimum of 1". Secure by sliding speed clips onto the end reflector edges. Evenly space the speed clips on the sides (two each side) and top (three each) of the reflectors to provide a snug fit.

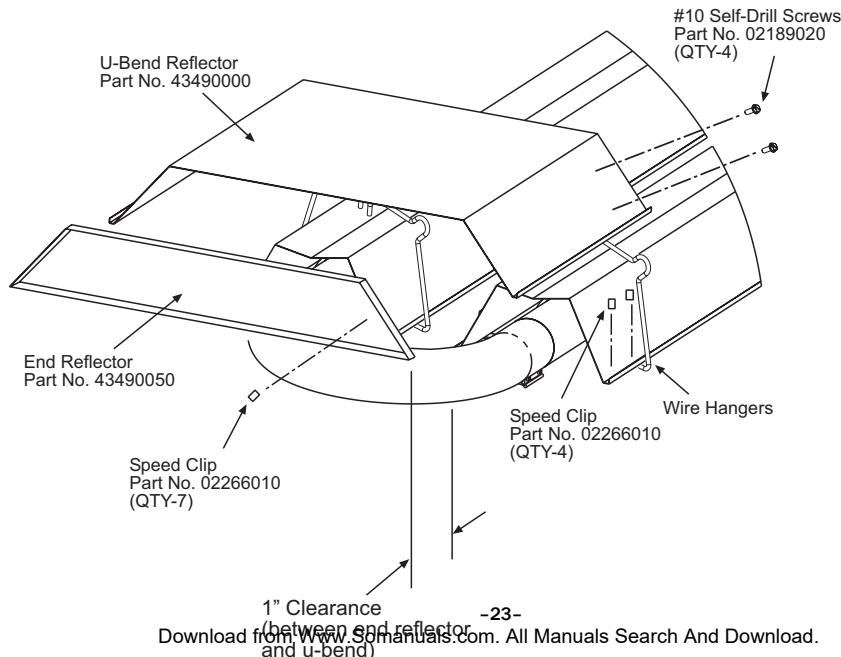

12.0) ATTACHING BURNER BOX ASSEMBLY

1. Attach the burner box and gasket to end of tube flange and secure with 1/4-20 locknuts.
2. Assemble the optional end reflector flush with the end of the main body reflector. Secure by sliding speed clips onto the reflector edges. Evenly space the speed clips on the sides (one each side) and top (two required) of the reflectors to provide a snug fit. Leave a 3" space between the end reflector and the burner box assembly.
3. The heater can be mounted **horizontally** or at an angle of up to **45 degrees** maximum from horizontal.

When angle mounting, the **burner box unit must** be positioned **upright** as shown below. **FAILURE TO INSTALL THE BURNER BOX IN AN UPRIGHT POSITION WILL VOID THE MANUFACTURER'S WARRANTY.**

! CAUTION
DO NOT lift burner or support it's weight using the TISS wire. It will break under heavy load.

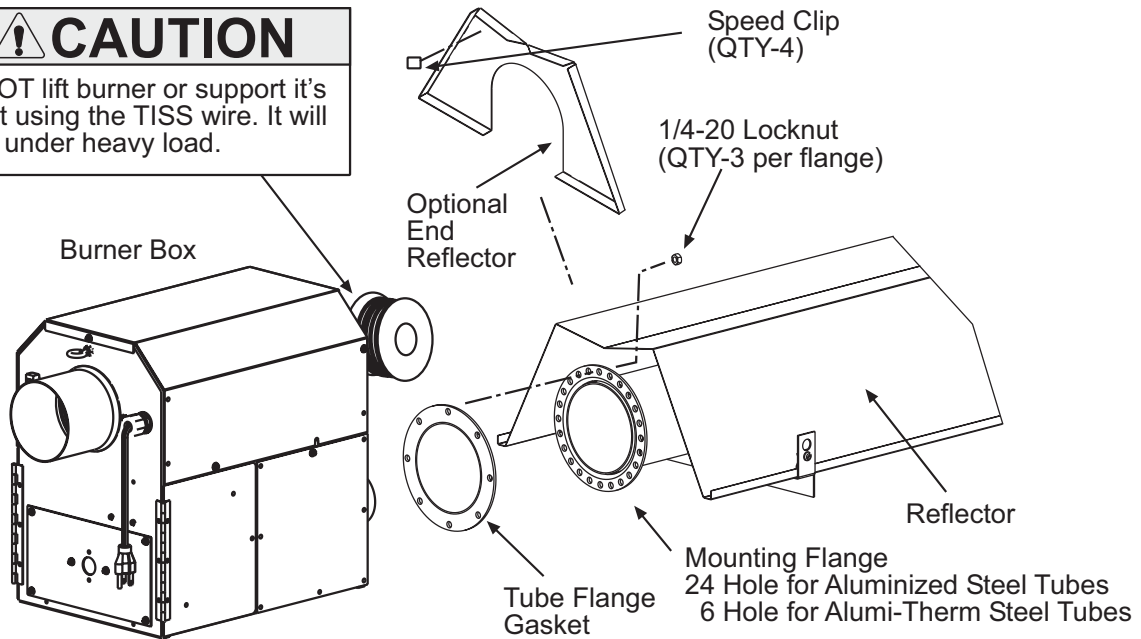

! CAUTION
Failure to install the burner box suspension chain will void manufacturers warranty.

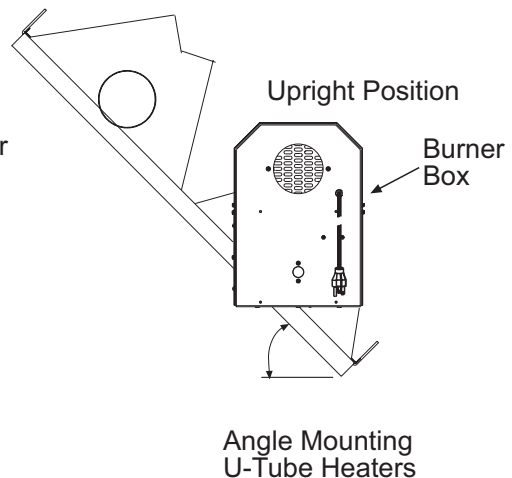
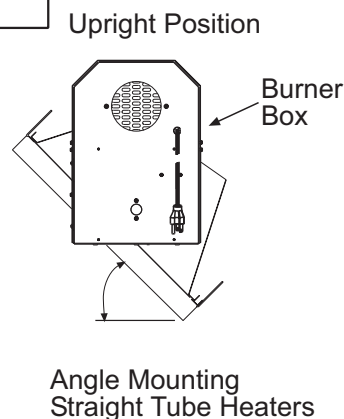
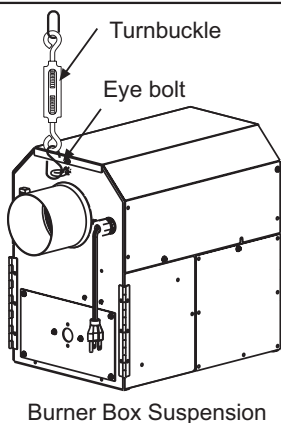

12.1) CONNECTING THE TISS SYSTEM

Description: The TISS (*Tube Integrity Safety System*) is designed to shut the main burner off in the event that a burnout occurs in the first 10ft. section of firing tube. **Note:** When replacing the firing tube a new TISS wire assembly PN 44176010 must also be installed.

Instructions:

1. Make sure that the gap between the burner box and end of reflector is 3" and the reflector is securely attached to the reflector support bracket. Make adjustments if necessary.

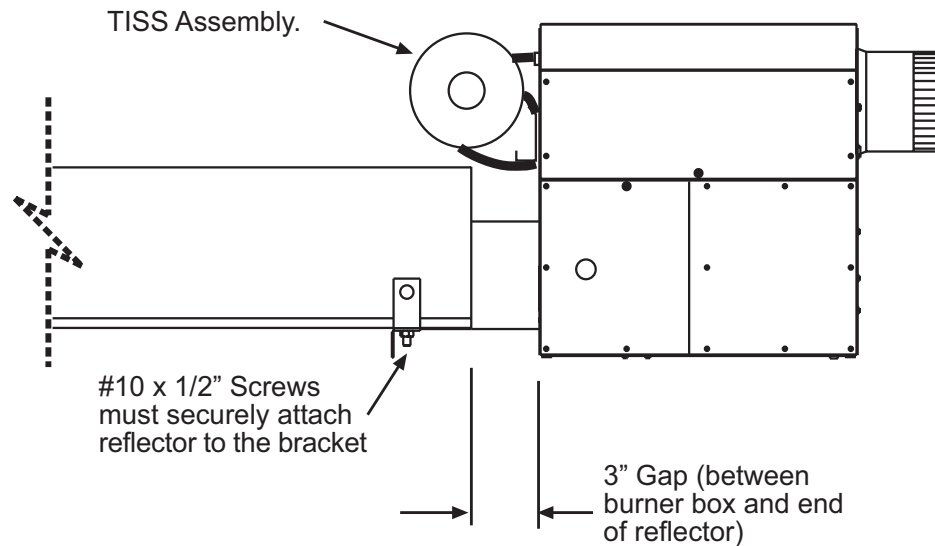

Step 1

2. Un-roll the TISS wire assembly from the spool. Be careful not to kink the wires.

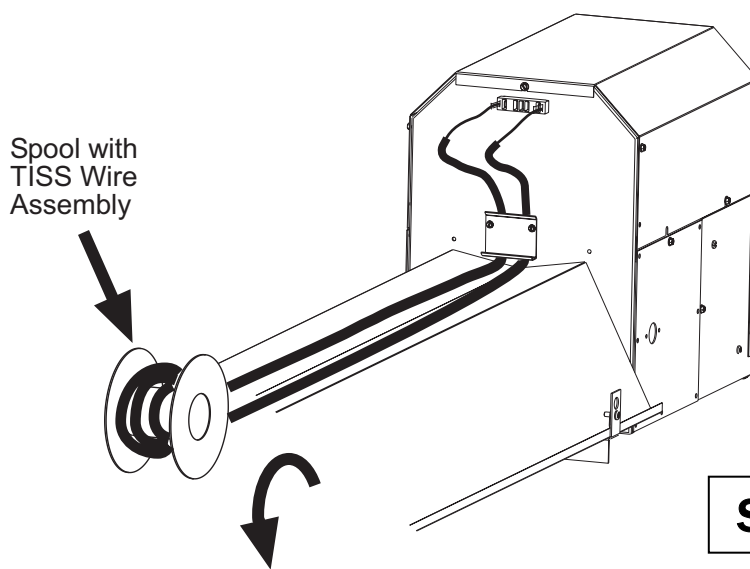

3. Hold the spring retainer clamp and pull the **TISS** wire assembly to end of reflector at overlap joint. Slide spring retainer clamp over end of reflector as shown.

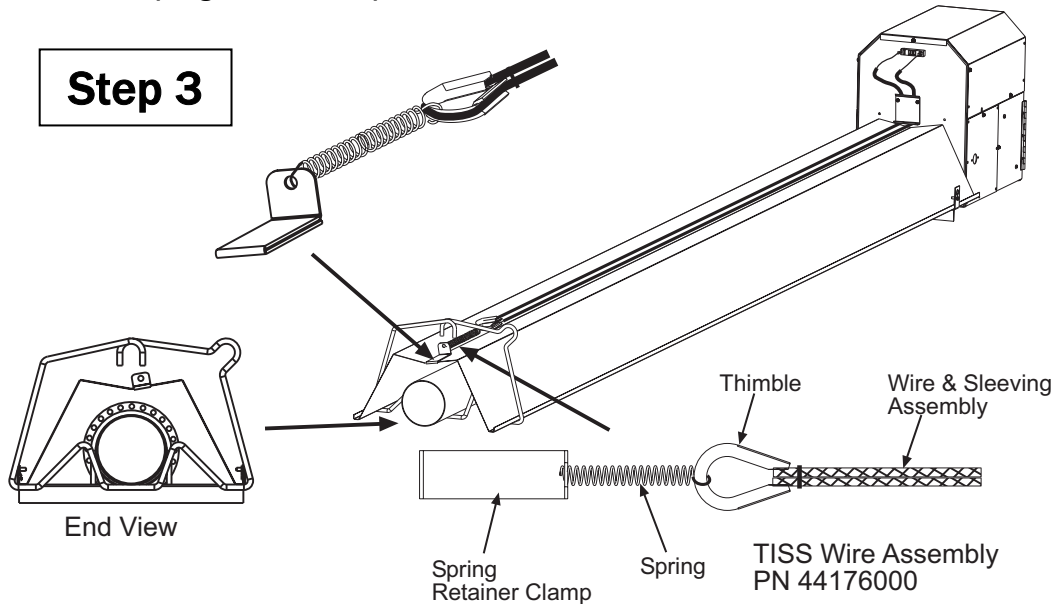

4. After attachment of the TISS, check to make sure that there is sufficient tension on the wire. Follow the diagram below to increase or decrease the tension as necessary.

1. Measure the extension of the spring from the end of the reflector to the thimble as shown below.

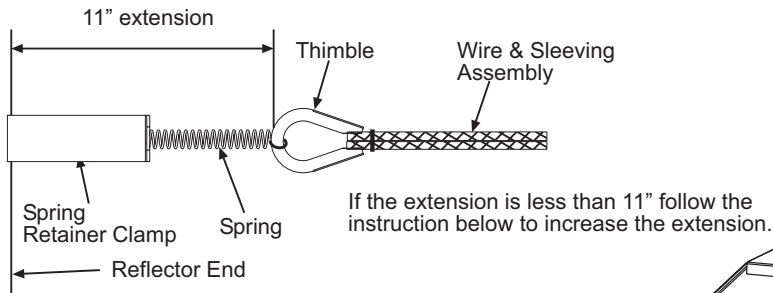

Step 4

2. Tape one end of the sleeve to the burner box or use a marker.

3. Mark the other end of the sleeve with tape or other marker. Use the top of the retainer as a reference.

4. Loosen screws.

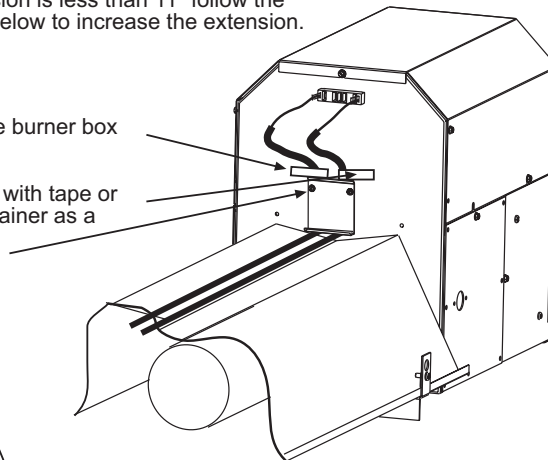

5. Pull one end of the sleeve and wire inside until the marker is raised by the total adjustment length. ie. if the extension is 10" then pull through 1" to increase the extension to 11".

6. Tighten screws.

7. Check extension using the method in step 1.

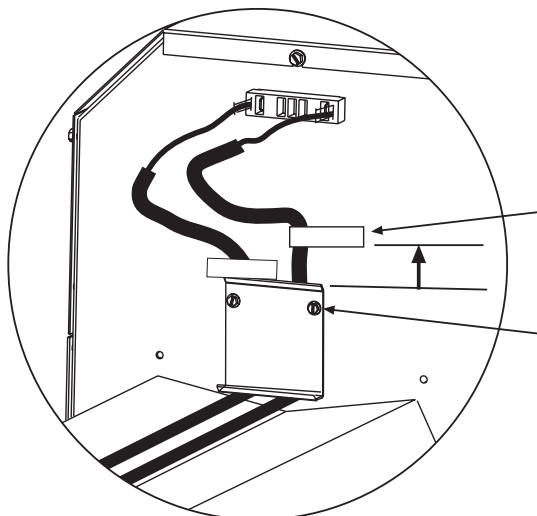

ANGLE MOUNTED HEATERS ONLY

5. If heaters are to be angle mounted, the TISS wire holder clamp must first be re-positioned as shown **using the bottom hole pattern** of the clamp. Follow procedures described earlier for all other adjustments.

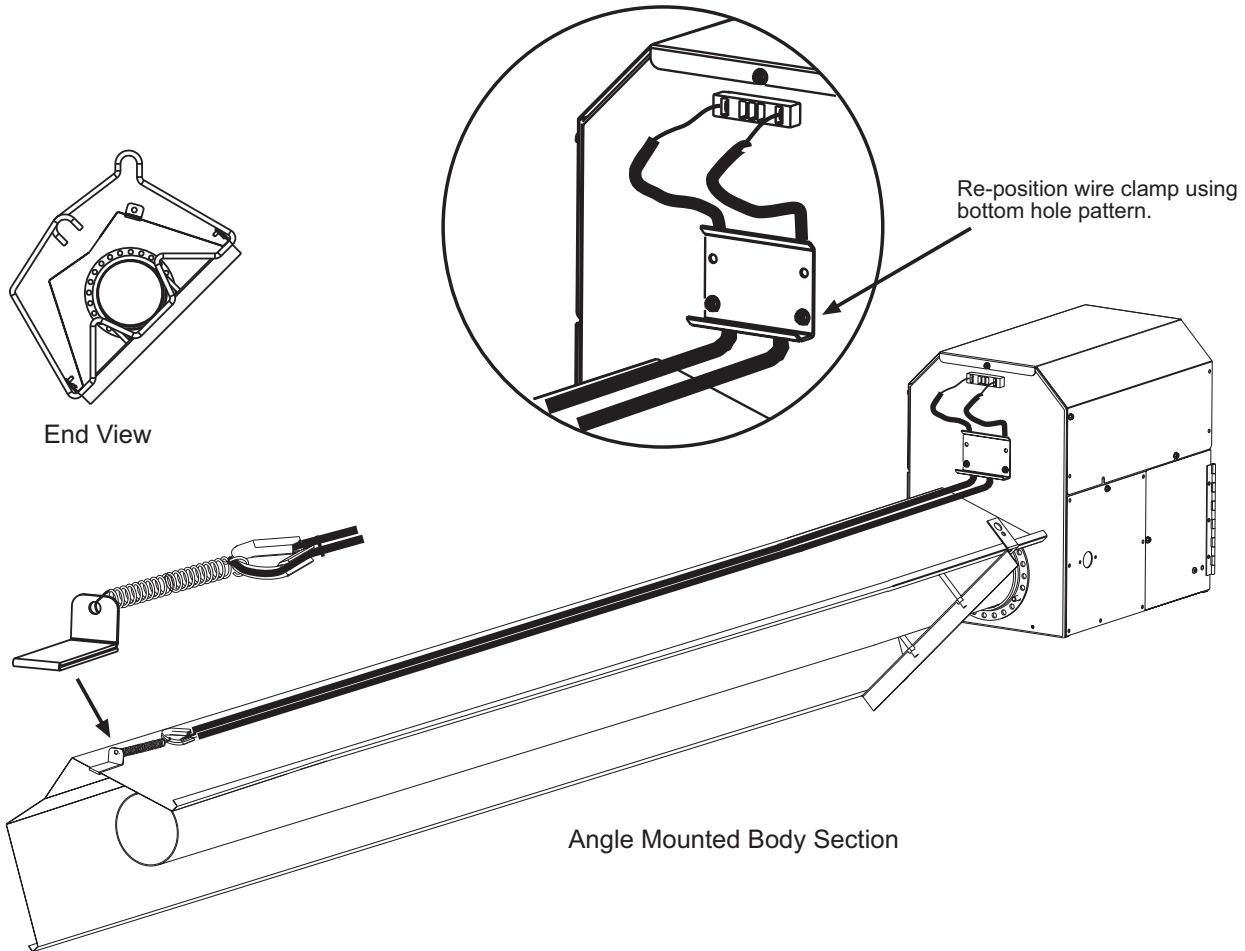

Step 5

13.0) GAS CONNECTIONS AND REGULATIONS

⚠ WARNING

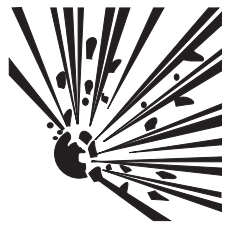

FIRE AND EXPLOSION HAZARD

Tighten flexible gas hose and components securely.

Flexible metal gas hoses must be installed without any twists or kinks in them. The hose will move during operation of the heater and it can crack if it is twisted.

Failure to do so may result in death, serious injury or property damage.

IMPORTANT BEFORE CONNECTING THE GAS TO THE HEATER

1. Connect to the supply tank or manifold in accordance with the latest edition of National Fuel Gas Code (ANSI Z223.1), and local building codes. Authorities having jurisdiction should be consulted before the installation is made. (In Canada, refer to the latest edition of CAN Standard B.149-1 & -2, Installation Codes for Gas Burning Appliances and Equipment.)
2. Check that the gas fuel on the burner rating plate matches the fuel for the application.
3. Check that the gas supply piping has the capacity for the total gas consumption of the heaters and any other equipment connected to the line.
4. Check that the calculated supply pressure with all gas appliances and heaters operating will not drop below the minimum supply pressure required for these heaters. Check inlet supply pressures on Section 14.
5. All gas supply lines must be located in accordance with the required clearances to combustibles from the heater as listed on the clearances label of the heater and section 4 of this manual.
6. Pipe joint compounds must be resistant to the action of liquefied petroleum gases.
7. Tube heaters will expand/contract during operation. Where local codes do not prohibit, a CSA or U.L. approved flexible connector supplied with this heater is required for connections between the rigid piping and the heater. A union should be installed before the burner box inlet. An approved shut off valve should be installed within 6 feet of the union.
8. The gas pipe, flexible hose and connections must be self supporting. The gas pipe work must not bear any of the weight of the heater or any other suspended assembly.
9. This appliance is equipped with a step-opening, combination gas valve. **The maximum supply pressure to the appliance is 14" W.C. or 1/2 P.S.I.** If the line pressure is more than the maximum supply pressure, then a second stage regulator which corresponds to the supply pressure must be used.
10. After all gas connections have been made, make sure the heater and all gas outlets are turned off before the main gas supply is turned on slowly. Turn the gas supply pressure on and check for leaks. To check for leaks, check by one of the methods listed in Appendix D of the National Fuel Gas Code.
11. If a 2nd stage regulator is used, the ball valve down stream in the supply line must be closed when purging the gas lines to prevent gas seeping through it. If initial gas pressure is higher than 14" w.c. the redundant combination gas valve is designed to lock out. Pressure build-up in the supply lines prior to the heater must be released before proper heater operation.

⚠ WARNING

DO NOT USE AN OPEN FLAME OF ANY KIND TO TEST FOR LEAKS.

KEY DIMENSIONS AND COMPONENTS OF THE GAS CONNECTIONS

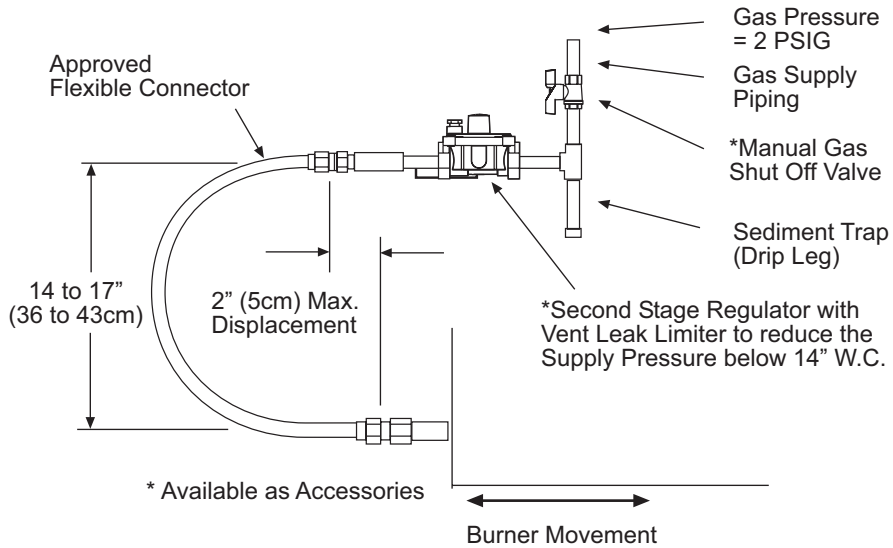

RECOMMENDED GAS CONNECTION POSITIONS WITH 36" FLEXIBLE GAS HOSE

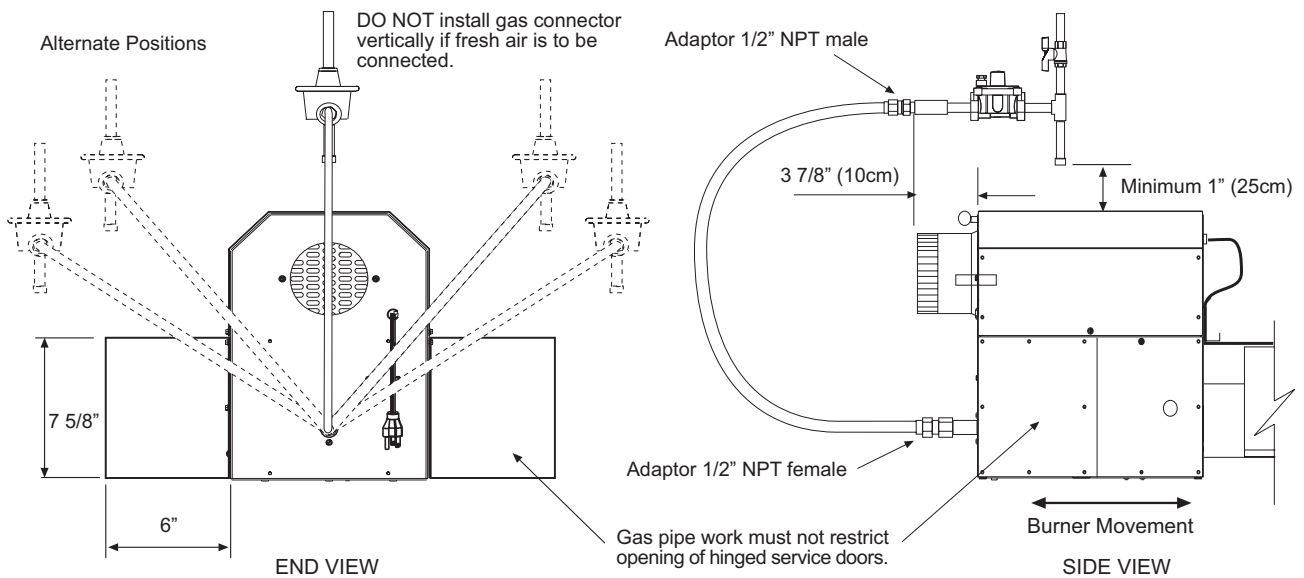

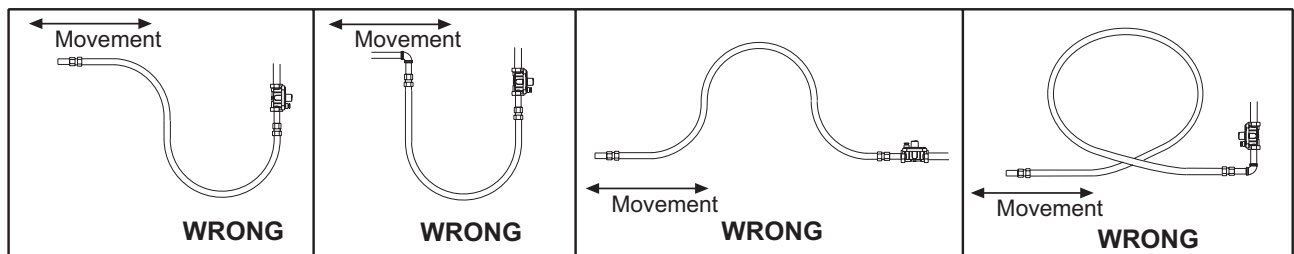

Certified connectors are recommended to be installed as shown, in one plane, and without sharp bends, kinks or twists.

INCORRECT POSITIONS

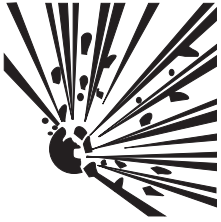

14.0) INSTRUCTIONS FOR PRESSURE TEST GAUGE CONNECTION

⚠ WARNING		
		<h3 style="margin: 0;">FIRE AND EXPLOSION HAZARD</h3> <p>Never operate the heater with the access panel open or removed.</p> <p>The access panels must be closed tightly with all the necessary screws during operation.</p> <p>Failure to do so may result in death, serious injury or property damage.</p>

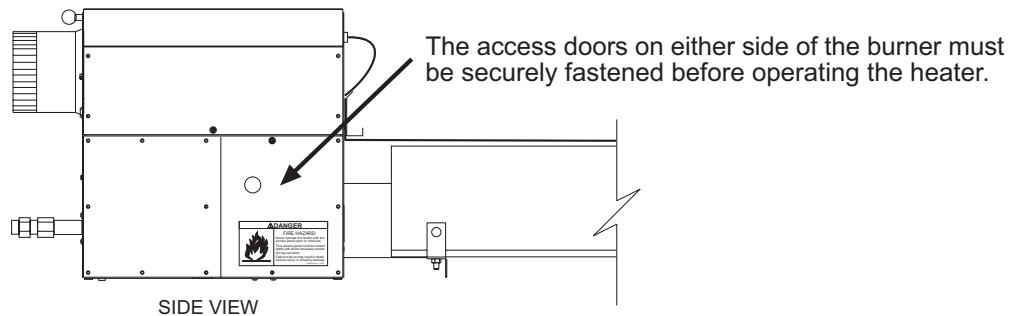

SUPPLY PRESSURE

1. The installer will provide a 1/8" N.P.T. tapped plug, accessible for test gauge connection immediately upstream of the gas supply connection to the heater.

MANIFOLD PRESSURE – COMBINATION GAS VALVE IS FACTORY SET

1. Turn the gas valve to the "OFF" position. Remove the 1/8" plug from the combination gas valve at the outlet pressure tap and connect a 1/8" nipple to the tapped hole. Connect the gauge to the nipple. Turn on the gas supply.
2. With the main burner operating, check the burner manifold pressure using a water column manometer. Gauges that measure pressure in pounds per square inch are not accurate enough to measure or set the manifold pressure. All measurements **MUST BE** made when this heater and all other gas burning equipment that is connected to the gas supply system are operating at maximum capacity.
3. **The combination gas valve is factory set and should not require adjustment.** If full rate adjustment is required, remove the cover screw. Using a small screwdriver, turn the adjustment screw clockwise ↻ to increase or counterclockwise ↺ to decrease the gas pressure to the burner. Replace the cover screw. **NOTE: The step opening pressure of this gas valve is not adjustable.**
4. Check the burner at step pressure, observing burner ignition and flame characteristics. The burner should ignite properly and without flashback to the orifice, and should remain lit.

GAS PRESSURE TABLE			
GAS TYPE	MANIFOLD PRESSURE	SUPPLY PRESSURE	
		<i>Minimum</i> *	<i>Maximum</i>
Natural Gas	3.5" W.C.	5" W.C.	14" W.C.
Propane Gas	10.0" W.C.	11" W.C.	14" W.C.

* Minimum permissible gas supply pressure for purpose of input adjustment.

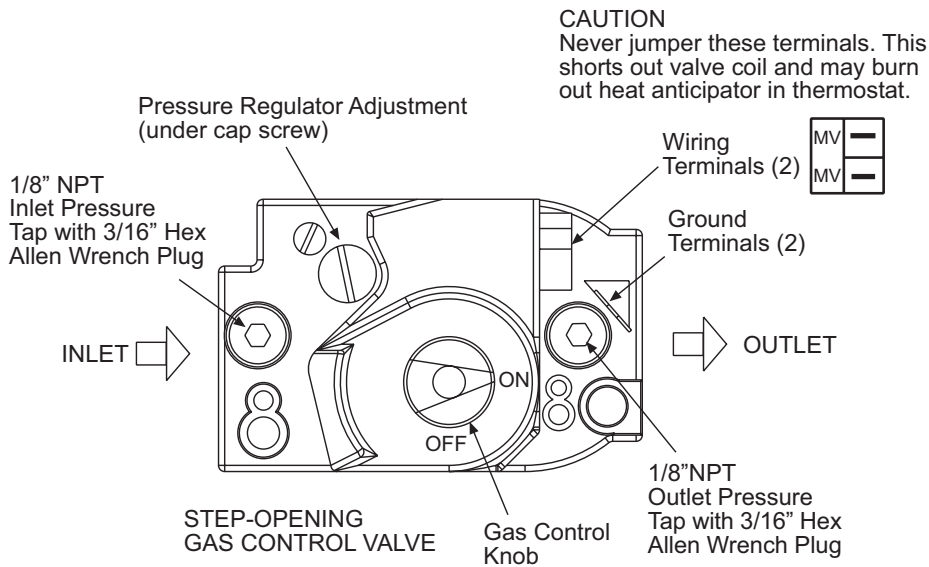

15.0) ELECTRICAL CONNECTIONS

⚠ WARNING

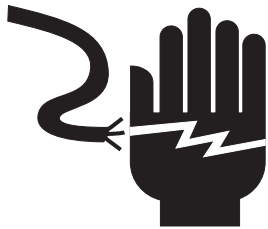

ELECTRIC SHOCK HAZARD

Disconnect electrical power and gas supply before servicing.

This appliance must be connected to a properly grounded electrical source.

Failure to do so may result in death or serious injury.

1. All electric wiring shall conform to the latest edition of the National Electrical Code (ANSI/NFPA No. 70), or the code legally authorized in the locality where the installation is made.
2. The unit must be electrically grounded in accordance with the National Electrical Code (ANSI/NFPA No. 70-latest edition). In Canada, refer to current standard C22.1 Canadian Electrical Code Part 1.
3. The wiring providing power to the heater shall be connected to a permanently live electrical circuit, one that is not controlled by a light switch.
4. The power supply to the unit should be protected with a fused disconnect switch or circuit breaker. A service switch, as required by local codes, shall be located in the vicinity of the heater (check local codes for allowable distances) and should be identified as Heater Service Switch. All electrical wiring must be located in accordance with the required Clearances to Combustibles below the heater as listed on the nameplate on the heater.
5. Connection to the power supply is provided by a 18/3 gauge x 72" long cord with grounded 3 prong plug.
6. The post purge function of the burner (fan on for 30 seconds after the call for heat) will only be enabled when using a 24 Volt thermostat. With the line Voltage thermostat post purge operation is disabled.

Optional 24V thermostat connection

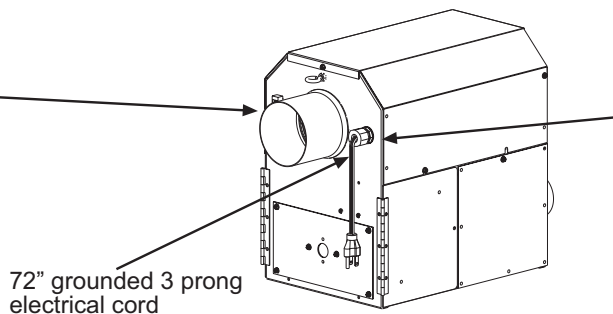
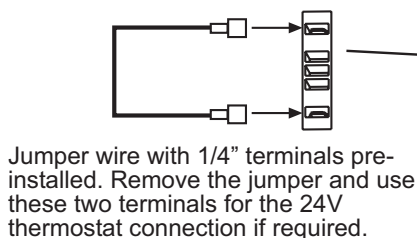

Liquid tight fitting must be tight to prevent ingress of moisture in harsh environments.

INTERNAL CONNECTION WIRING DIAGRAM — Direct Spark Ignition

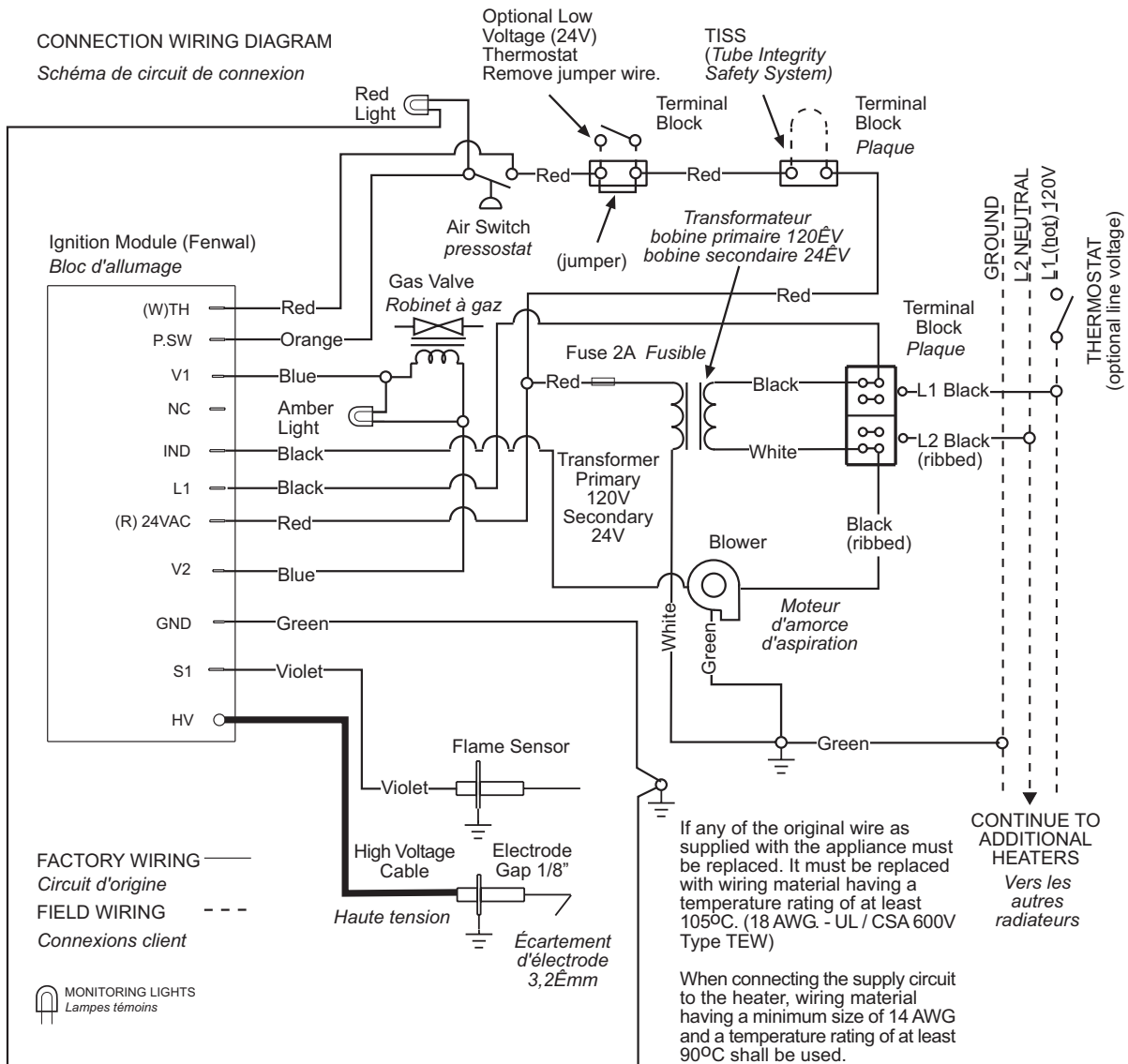

IGNITION MODULE TERMINAL DESIGNATIONS	
24VAC/R	24 VAC Supply to Module
TH/W	Thermostat Input
PS/W	Pressure Switch Input
GND	System Ground
V1	Valve Power
V2	Valve Ground
L1	120/240 VAC Input (Hot)
IND	Blower Output
NC	Alarm (if equipped)
S1	Remote Flame Sensor

NOTES:

1. If any of the original wire as supplied with the appliance must be replaced, it must be replaced with wiring material having a temperature rating of at least 105°C. (18 Ga. CSA 600V Type TEW)
2. When connecting the supply circuit to the heater, wiring material having a minimum size of 14 AWG and a temperature rating of at least 90°C shall be used.

FIELD CONNECTION WIRING DIAGRAMS

A. LINE VOLTAGE (120V) THERMOSTAT CONNECTIONS - SINGLE HEATER

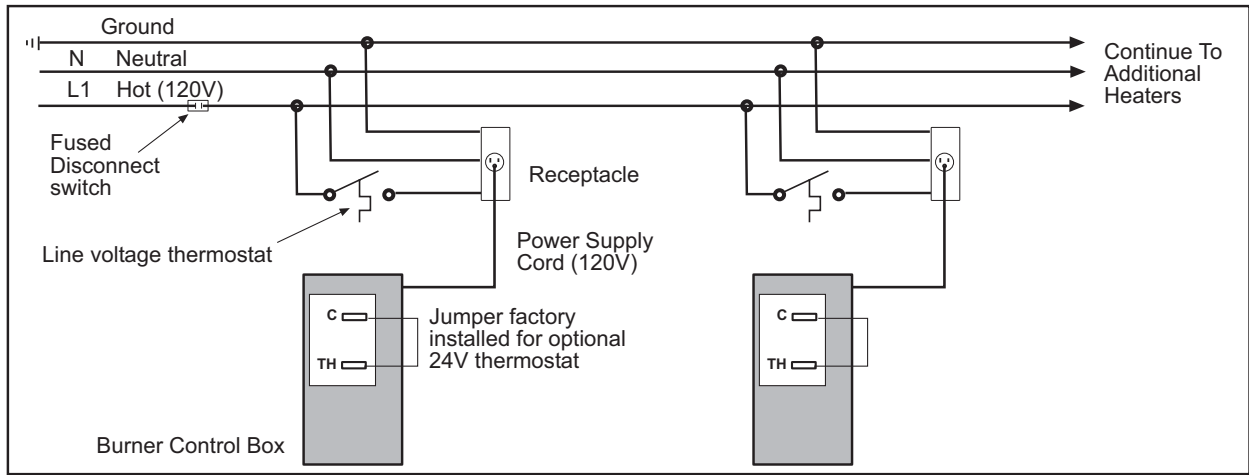

B. LINE VOLTAGE (120V) THERMOSTAT CONNECTIONS - MULTIPLE HEATERS

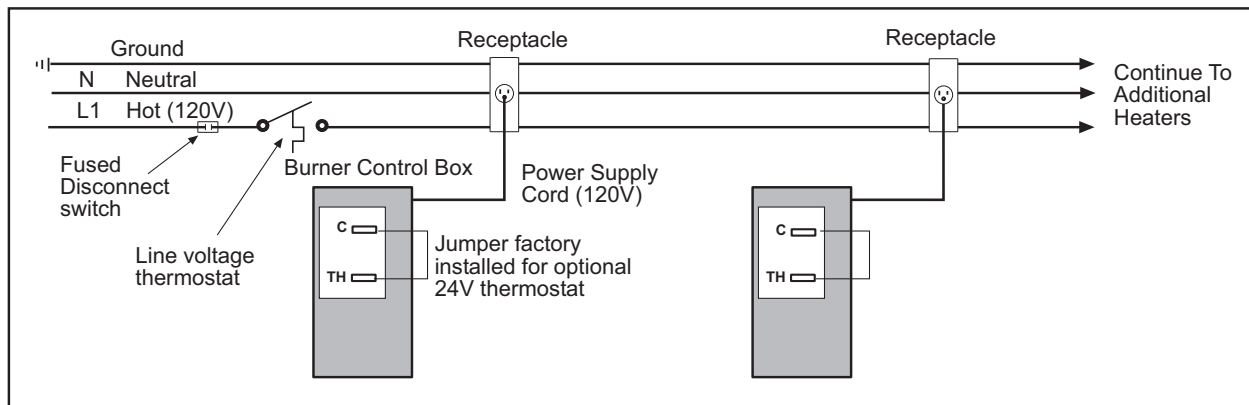

C. LOW VOLTAGE (24V) THERMOSTAT CONNECTIONS - SINGLE HEATERS

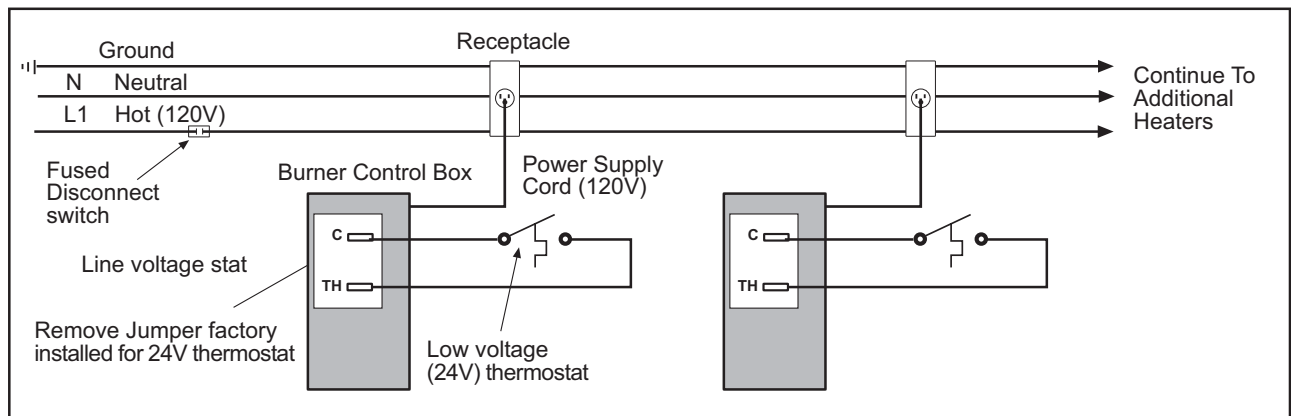

D. LOW VOLTAGE (24V) THERMOSTAT CONNECTIONS – MULTIPLE HEATERS (utilizing a fan center relay)

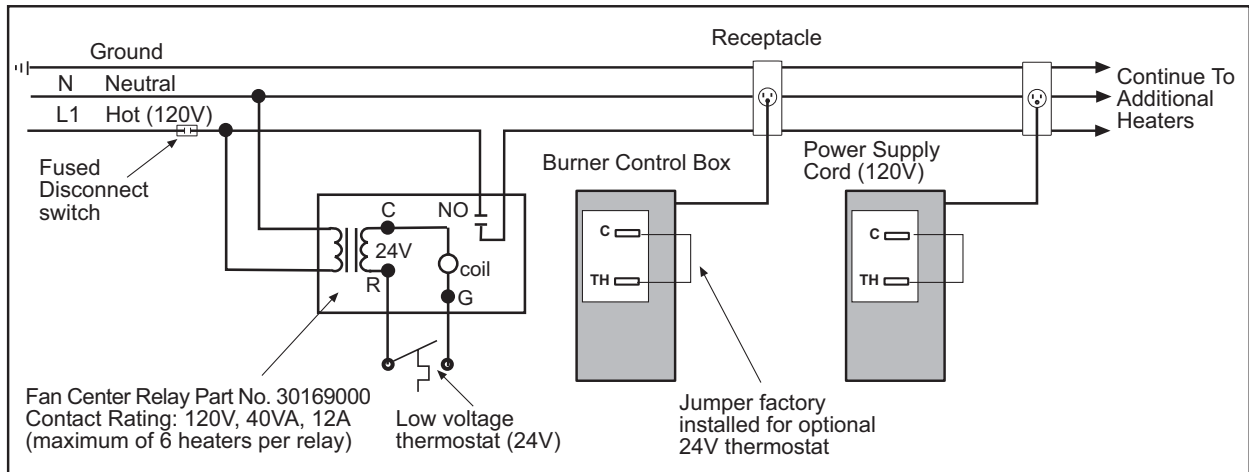

16.0) VENTING

⚠ WARNING

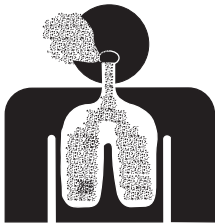

CARBON MONOXIDE HAZARD

Heaters installed in an unvented mode require a minimum ventilation flow of 4 CFM per 1,000 Btu/hr of total installed capacity.

In buildings with airborne contamination such as poultry houses the heater must be installed with fresh air for combustion.

Failure to do so may result in death, serious injury, property damage or illness from Carbon Monoxide poisoning.

A. BASIC FLUE VENTING — Venting must comply with the latest edition of the National Fuel Gas Code (ANSI Z223.1-latest edition) or the authority having jurisdiction. Other venting references are in the equipment volume of the ASHRAE Handbook.

Model	Heat exchanger length ft	Maximum vent length ft. (4" diameter)	Maximum Fresh air intake length ft (4" diameter)	Max. combination of fresh air and vent ft. (4" diameter)
PTS/U 40	20	45	50	75
PTS/U 50	20	45	50	75
PTS/U 50	30	35	40	65
PTS/U 75	20	45	50	75
PTS/U 75	30	35	40	65
PTS/U 100	30	45	50	75
PTS/U 100	40	35	40	65
PTS/U 125	30	60	50	75
PTS/U 125	40	50	40	65
PTS/U 125	50	40	30	55
PTS/U 150	40	60	50	75
PTS/U 150	50	50	40	65
PTS/U 150	60	40	30	55
PTS/U 175	50	60	50	75
PTS/U 175	60	50	40	65
PTS/U 175	70	40	30	55
PTS/U 200	50	60	40	65
PTS/U 200	60	50	30	55
PTS/U 200	70	40	30	45

Vent lengths shown in the table are for horizontal and vertical venting. If a longer length of vertical or horizontal venting is required contact the manufacturer for assistance with vent sizing.

SINGLE HEATER VENTING (VERTICAL THROUGH THE ROOF)

1. When venting the heater to outside of building through a roof, use single-wall metal pipe. This is to be constructed of galvanized sheet metal or other approved noncombustible corrosion-resistant material as allowed by state or local codes.
2. A vent passing through a combustible roof shall extend through an approved clearance thimble. Double-wall, Type B vent must be used for the portion of the vent system which passes through the roof. An approved vent cap (Leslie "VersaCap"-Type B or equal) must be attached to end of the flue.
3. The maximum equivalent length of vent pipe should be carefully observed. A safety switch in the heater is designed to shut the heater off before excessive flue restriction causes bad combustion. Refer to the Vent Sizing Table for maximum vent lengths and vent pipe diameter.
4. Joints between sections of piping shall be fastened by sheet metal screws or other approved means and should be sealed to prevent leakage of flue gas into building. Aluminum or Teflon tape suitable for 550°F (3M Company tapes 433 or 363) or silicone sealant is recommended.
5. All portions of the vent pipe shall be supported to prevent from sagging (6' spacing is recommended).
6. When the vent pipe passes through areas where the ambient temperature is likely to induce condensation of the flue gases, the vent pipe should be insulated and a condensation drain should be provided.
7. Minimum clearance for single-wall flue pipe to combustible material shall be 6 inches. This may be reduced when the combustible material is protected as specified in the National Fuel Gas Code or the authority having jurisdiction.
8. Single-wall metal pipe shall not originate in any unoccupied attic or concealed space and shall not pass through any attic, inside wall or concealed space, or through any floor. For the installation of a single-wall metal pipe through an exterior combustible wall, refer to latest edition of the National Fuel Gas Code or the authority having jurisdiction.
9. A venting system shall terminate at least 3 ft. above any forced air inlet located within 10 ft.

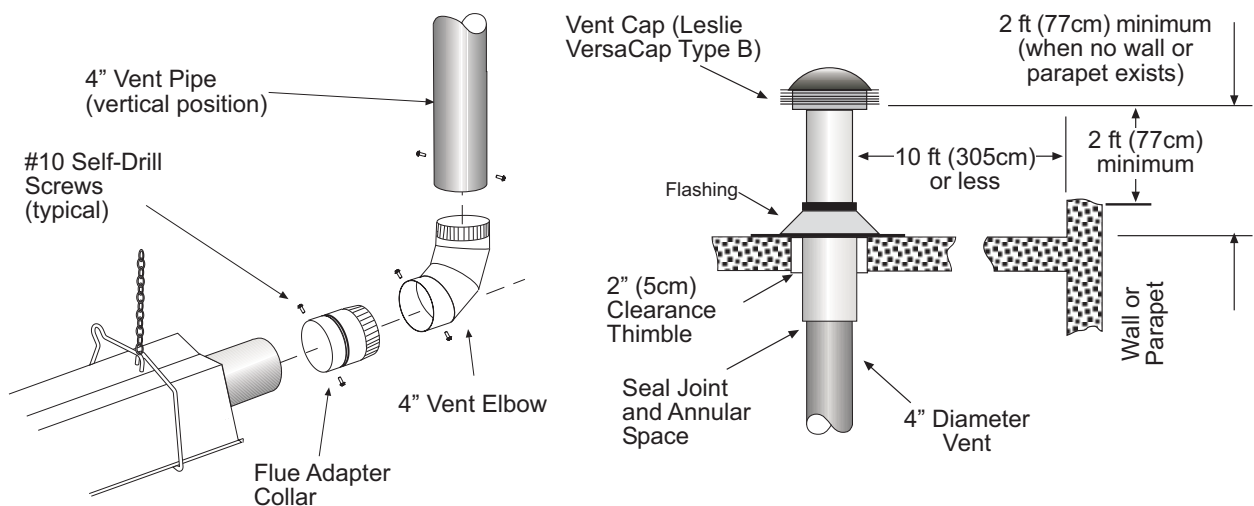

SINGLE HEATER VENTING (HORIZONTAL THROUGH SIDEWALL)

When venting the heater horizontally through a combustible outside sidewall, the same requirements listed previously for venting **Vertical Through The Roof** apply except as follows:

1. A vent passing through a combustible wall must pass through an approved clearance thimble (Air-Jet #4VT or Ameri-Vent #4EWT or other thimbles that are listed by a nationally recognized testing agency).
2. An approved vent cap (Braidert-Type L or equal) must be attached to the end of the vent pipe.

NOTE: To minimize problems associated with condensation in long horizontal runs, vent pipe can be insulated.

3. Use the following correction factors to obtain the equivalent length when elbows are used:
 - c. Subtract 10 ft. for each elbow beyond 15 ft. from the heater.
 - d. Subtract 15 ft. for each elbow within 15 ft. of the heater.
4. Limit to (2) 90° elbows in the vent system.
5. When venting through a sidewall, the horizontal vent pipe shall fall not less than 1/2 inch per 20 feet from the start of the vent system to the vent terminal. All portions of the vent pipe shall be supported to prevent sagging. (6' spacing is recommended)
6. A minimum clearance of 6 inches must be maintained between the outside wall and vent cap.

7. The horizontal venting system shall not terminate:
 - a. Less than 4 ft. (1.2m) below, 4 ft. (1.2m) horizontally from or 1 ft. (30cm) above any door, operable window or gravity air inlet into any building. The bottom of the vent terminal shall be located at least 7 ft. (2.1m) above grade or above snow accumulation level as determined by local codes.
 - b. Less than 3 ft. (0.9m) from a combustion air inlet.
 - c. Less than 3 ft. (0.9m) from any other building opening or any gas service regulator.
 - d. Less than 7 ft. (2.1m) above public walkways.
 - e. Directly over areas where condensate or vapor could create a nuisance or hazard or be harmful to the operation of gas utility meters, regulators, relief valves, or other equipment. Building materials should be protected from flue gases and condensate.
8. In regions of the country where prevailing winds are consistently higher than 40 mph, it may be necessary to terminate the vent system above the roof level.

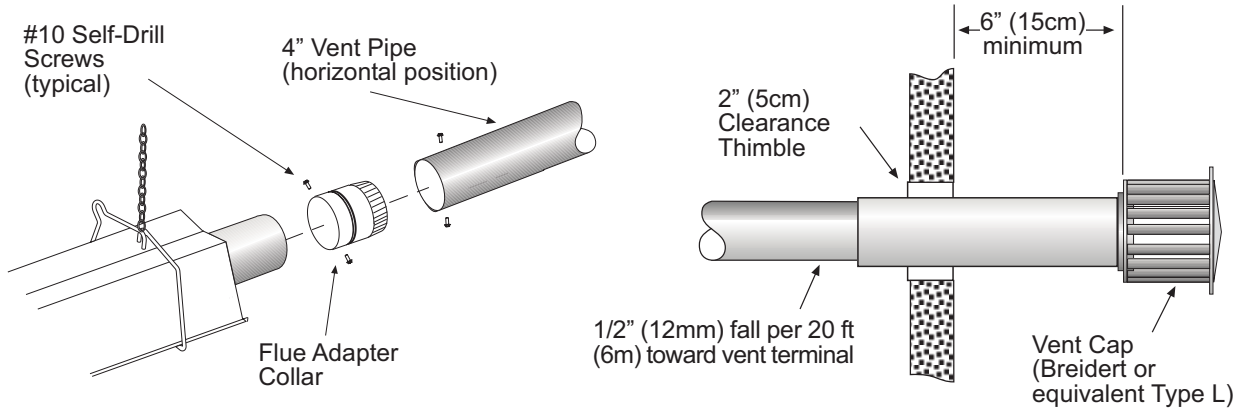

MULTIPLE HEATER VENTING (CONNECTIONS INTO A COMMON VENT OR MANIFOLD)

Requirements for venting of multiple heaters are the same as described for **SINGLE HEATER VENTING** except as follows:

1. The common vent size and total vent height is normally determined by the number of heaters per common vent, length of horizontal connector runs, and connector rise. Connector lengths should be as short as possible and have a minimum 1/2 inch per 20 foot fall. Without regard to connector rise and total vent height due to many possible venting configurations, the following should be observed:
 - a. Common vent pipe & vent connector diameter should be no less than that shown in the following Vent Sizing Table.
 - b. The connector length should be no more than 75% of the vertical portion of vent above the connector.
 - c. Where possible, use a Y-connector to the common vent.
2. Material for connectors should be constructed of galvanized sheet metal or other approved noncombustible corrosion resistant material as allowed by state or local codes. All common vent pipe should be double wall, Type B vent.
3. Avoid unnecessary bends. Limit to two (2) 90° elbows.
4. The entire length of vent connector shall be readily accessible for inspection, cleaning and replacement.
5. Groups of heaters with a common vent must be controlled by a common thermostat.

! WARNING

COMMON VENTING OF MULTIPLE HEATERS IN CONFINED SPACES IS PROHIBITED. If any heater connected to a common vent system for multiple heaters is found inoperative, the heater should be disconnected from the vent system and its entrance into the vent system capped.

Multiple Heater Vertical venting arrangement.

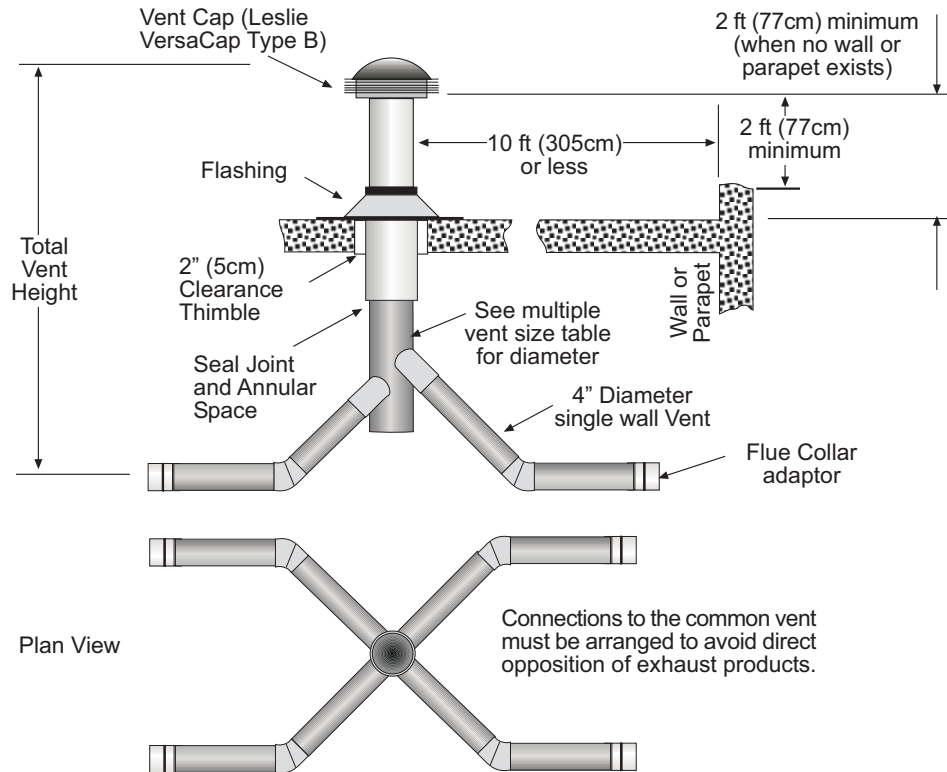

Multiple Heater Horizontal venting arrangement.

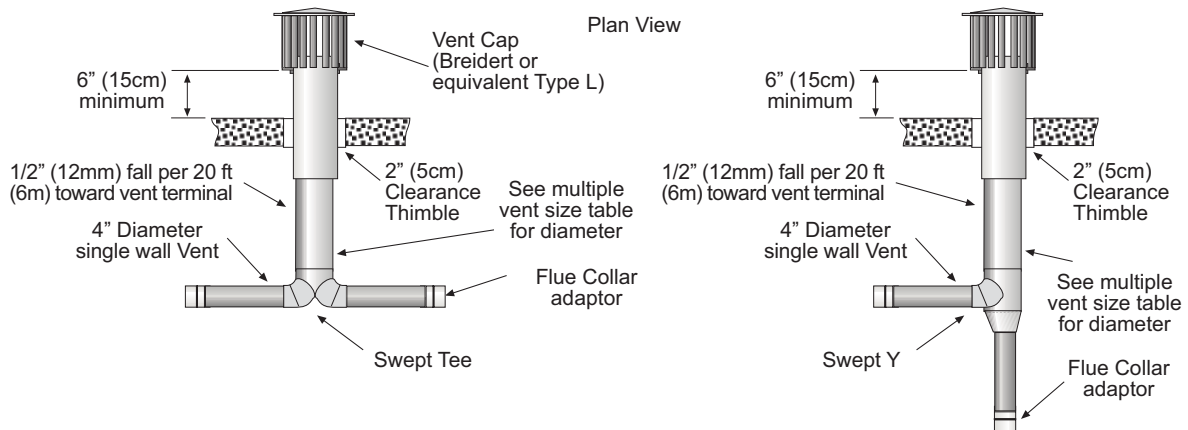

VENT SIZING TABLE — Multiple Heater Venting				
	Number of Heaters			
	Horizontal and vertical		Vertical Only	
	1	2	3	4
PTS/PTU 40	4"	4"	4"	4"
PTS/PTU 50	4"	4"	4"	5"
PTS/PTU 75	4"	4"	5"	6"
PTS/PTU 100	4"	5"	6"	6"
PTS/PTU 125	4"	5"	6"	7"
PTS/PTU 150	4"	6"	7"	7"
PTS/PTU 175	4"	6"	7"	8"
PTS/PTU 200	4"	6"	7"	8"

COMMON VENT DIAMETER
(If a size is not available use the next larger size.)

B. INDIRECT VENTING (UNVENTED HEATERS) — This heater requires ventilation in the building to dilute the products of combustion and provide fresh air for efficient combustion. Where unvented heaters are used, gravity or mechanical means shall be provided to supply and exhaust at least 4 CFM per 1,000 Btu/hr input of installed heaters. Exhaust vents must be located at the highest point above and in the vicinity of the heaters, and the inlet vents must be located below the level of the heaters. An exhaust hood (Part #42924000) must be placed on the flue adapter collar located on the end of the last body section when used unvented and must be mounted only in an downward position as shown.

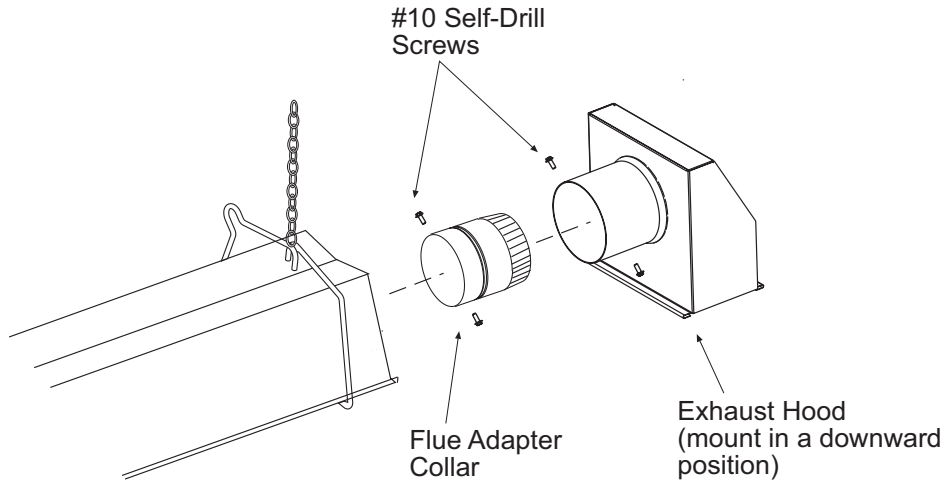

Exhaust Hood Attachment
(for UNVENTED use)

17.0) AIR FOR COMBUSTION

If indoor combustion air is to be supplied for a tightly enclosed area, one square inch of free area opening shall be provided below the heater for each 1,000 Btu/hr of heater input. Adequate clearances around the air inlet screen must be maintained at all times. In larger open areas of buildings, infiltration normally is adequate to provide air for combustion.

17.1) DIRECT OUTSIDE AIR FOR COMBUSTION

Outside combustion air should be supplied directly to the heater when the building is subject to negative pressure, or when contaminants or high humidity are present in the building air. These contaminants include paints, solvents, corrosive vapors or any other foreign particles that may cause damage to the heater or result in poor combustion.

Outside combustion air can be brought directly to the heater by a 4" diameter duct less than 50 ft. long or equivalent (see table in Section 16). This is attached to the 4" diameter starting collar (supplied with heater). The starting collar is fitted to the rear of the burner box cabinet as shown below. An approved vent cap must be placed directly on the end of the outside combustion air inlet pipe. The combustion air inlet should be not less than 3 ft. (0.9m), either vertically or horizontally, from the flue vent termination. The air intake terminal must be located not less than 1 ft. (30cm) above grade. It is good installation practice to supply combustion air from the same pressure zone as the vent outlet. Avoid bringing combustion air to the heater from an attic space. There is no guarantee that adequate combustion air will be supplied.

If the heater is installed less than 2 ft. from the ceiling, a combustion air inlet kit PN 44129510 must be provided to allow for expansion/contraction of straight tube heaters (PTS series).

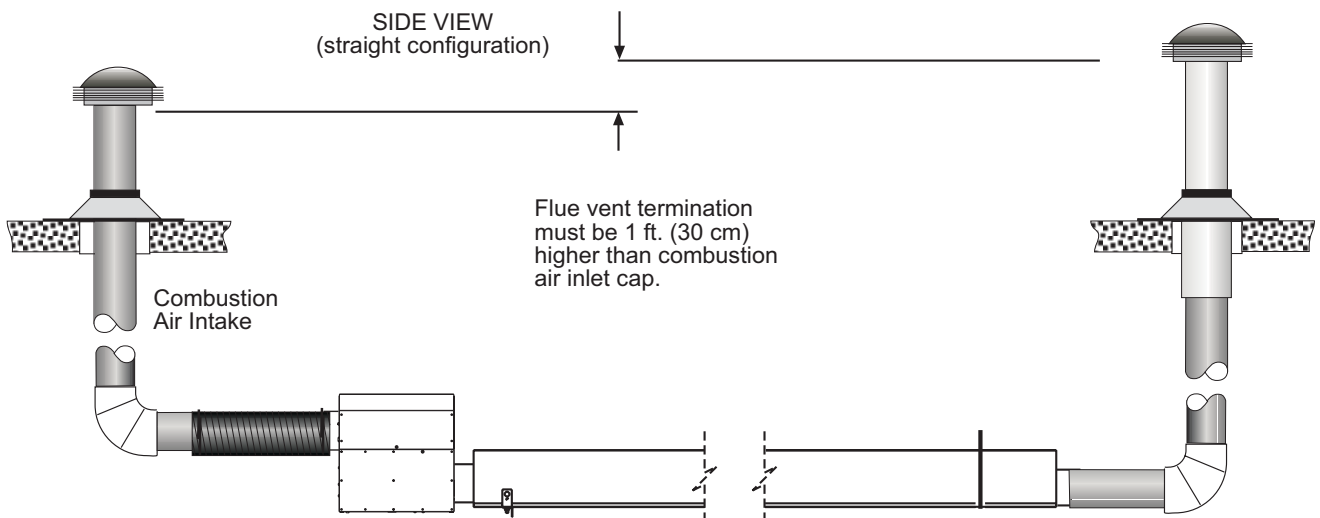
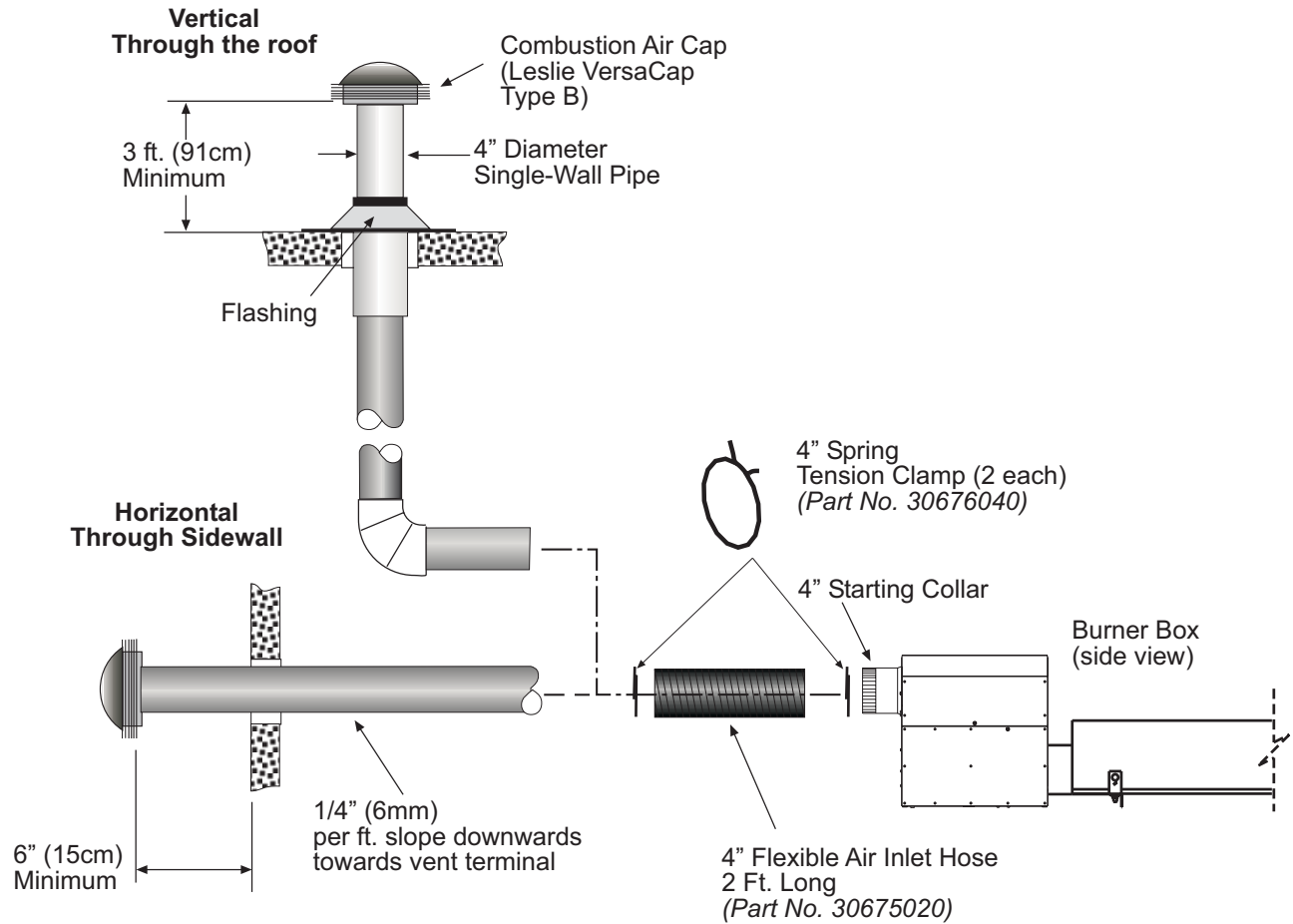

In colder climates, where necessary, insulate the outside combustion air duct. In high humidity applications, the burner box should be sealed with silicone sealer.

In **multiple heater applications**, the combustion air intake may be ducted individually or common ducted in the same configuration as shown for venting in Section 16.0. For combustion air intake duct sizing, please refer to the **Vent Sizing Table** and use the diameter indicated, based on the number of heaters per duct.

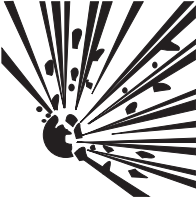

18.0) LIGHTING AND SHUTDOWN INSTRUCTIONS

⚠ WARNING







FIRE AND EXPLOSION HAZARD

Never operate the heater with the access panel open or removed.

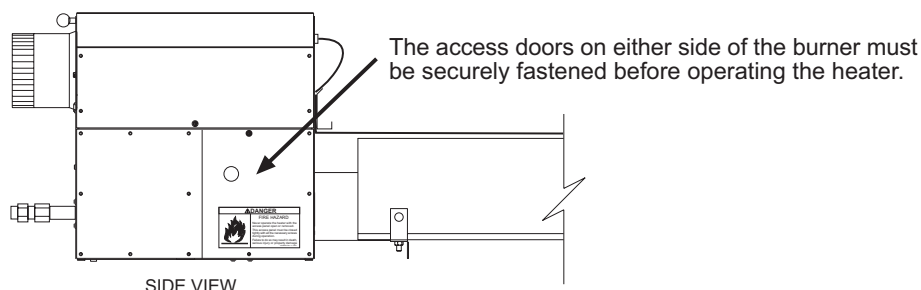
The access panels must be closed tightly with all the necessary screws during operation.

Failure to do so may result in death, serious injury or property damage.



- 1) Turn on the gas and electrical supply. Rotate the gas valve knob counter-clockwise  to the "ON" position.
- 2) Set the thermostat to call for heat. The blower motor will energize.
- 3) Ignition should occur after the 15-second pre-purge.
- 4) If the burner fails to light, or flame is not detected during the first trial for ignition (a period of approximately 15 seconds) the gas valve is de-energized and the control goes through an inter-purge delay of approximately 60 seconds before another ignition attempt. The control will attempt two additional ignition trials before going into lockout, and the valve relay will be de-energized immediately. The blower will be turned off following a post-purge period of approximately 30 seconds.
- 5) If the heater does not light, manually reset the thermostat or shut off power completely for 5 minutes before attempting to relight.
- 6) To permanently shut down the heater, rotate the gas valve knob clockwise  to the "OFF" position and turn off the gas and electrical supply.

NOTE: THE LIGHTING AND SHUTDOWN INSTRUCTIONS ARE ALSO SHOWN ON THE PERMANENT NAMEPLATE LABEL ATTACHED TO THE HEATER.

19.0) SEQUENCE OF OPERATION

The chart below shows the sequence of operation for the normal operating cycle of the PTS/PTU when connected to a permanent 120V power supply and the heater is turned on and off by a remote 24V thermostat. (Electrical connection diagram C).

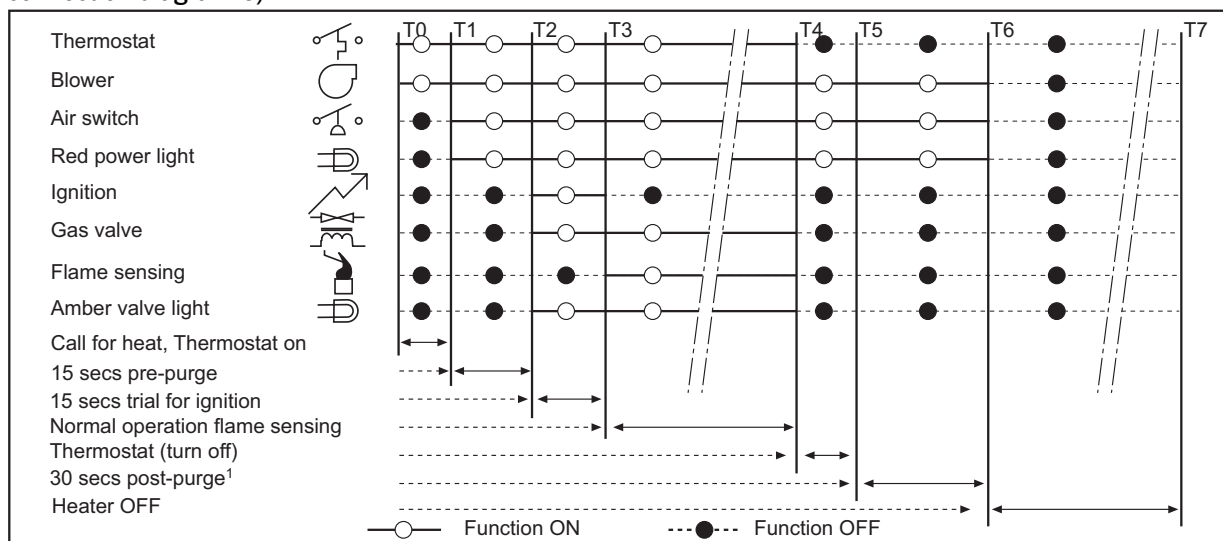

Note¹: When the PTS / PTU is operated by a thermostat interrupting the line voltage (120V) to the heater then the post purge function is disabled.

If the flame is not sensed during sequence T3 then the burner will automatically begin re-ignition sequence T2. The ignition sequence will be repeated three times with a 60 second inter-purge. If the flame is not re-established the heater will go to lockout.

20.0) BURNER COMPONENT LOCATIONS

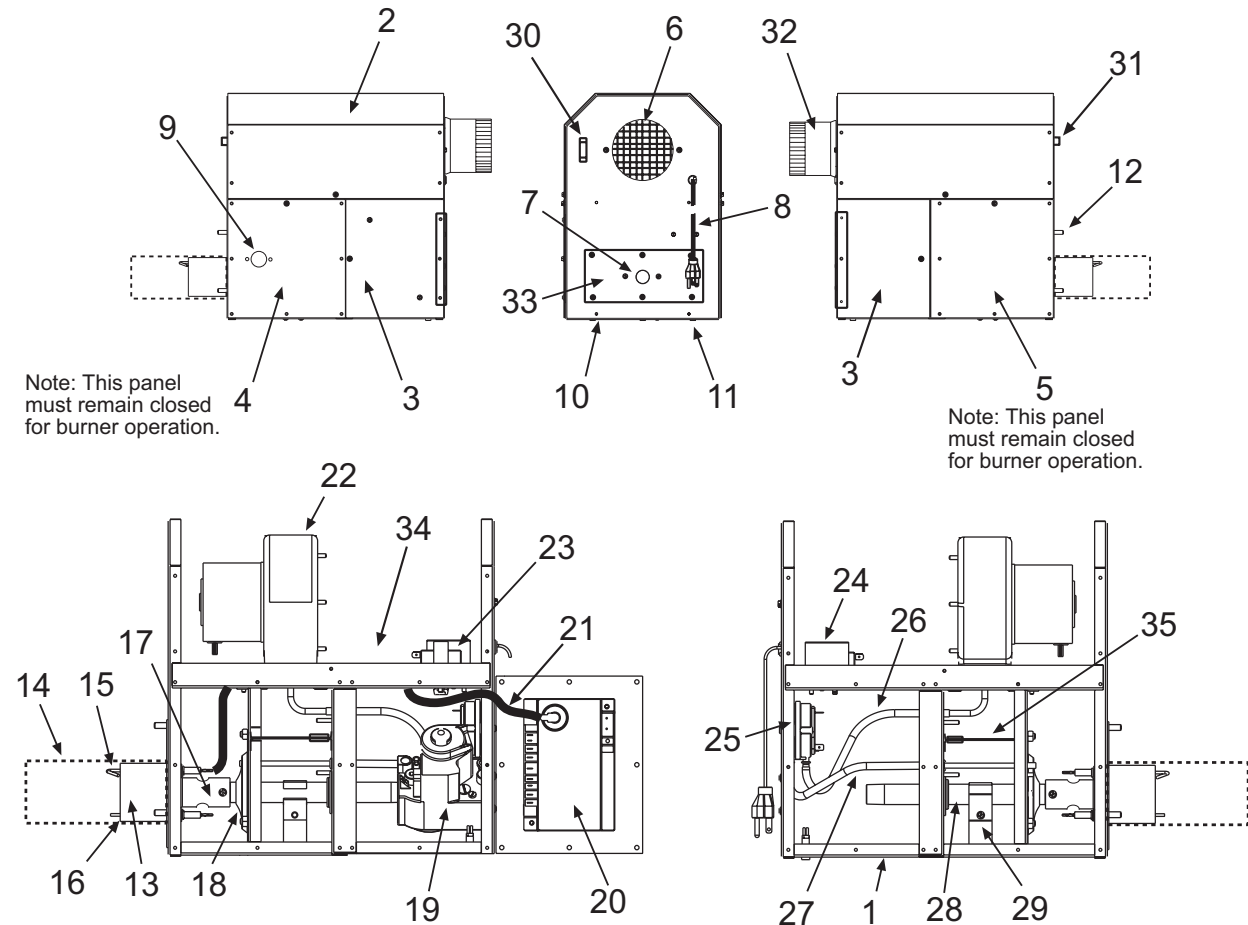



Note: This panel must remain closed for burner operation.

Note: This panel must remain closed for burner operation.

Legend:

1	Cabinet Assembly	19	Gas Control Valve
2	Access Panel - Top	20	Ignition Module
3	Access Panel - Hinged (2 ea)	21	Ignition Cable
4	Access Panel - LH Burner	22	Blower Assembly
5	Access Panel - RH Burner	23	Transformer - 120/24 VAC
6	Air Inlet Screen	24	Terminal Block/Fishpaper Shield
7	Gas Inlet Connection - 1/2"NPT	25	Air Switch
8	Power Supply Cord - 120V	26	Air Sensing Tube (P1+)
9	Burner Sight Glass	27	Air Sensing Tube (P2-)
10	Indicator Light - Amber (Gas Valve)	28	Manifold Pipe
11	Indicator Light - Red (Air Switch)	29	Manifold Support Bracket/Clamp
12	Tube Flange Connection	30	Terminal Block (24V thermostat)
13	Main Burner	31	Terminal Block (TISS connection)
14	Flame Screen (200m/BTU units only)	32	Starting Collar
15	Electrode	33	Valve Holder Plate
16	Flame Sensor	34	Fuseholder/Fuse (2 amp)
17	Main Burner Orifice	35	Combustion Air Plate
18	Air Restrictor Plate		

21.0) CLEANING AND MAINTENANCE

⚠ WARNING		
		ELECTRIC SHOCK & EXPLOSION HAZARD Disconnect electrical power and gas supply before servicing. Failure to do so may result in death or serious injury.

This heater must be cleaned and serviced annually by a qualified contractor before the start of each heating season and at any time excessive accumulation of dust and dirt is observed. Maximum heating efficiency and clean combustion will be maintained by keeping the heater clean.

The contractor shall check the following during periodic maintenance.

- **Clearances to combustibles:** Check that clearances are being maintained. Make sure there are no flammable objects, liquids or vapors near the heater. See also Section 4.
- **Reflectors:** Reflectors should be kept clean, at a minimum blow off the reflectors. (Dirty reflectors will reduce heat output).
- **Heat exchanger tubes:** Inspect the heat exchanger tubes to make sure they are not cracked, sagging or showing signs of fatigue.
- **Combustion air intake:** Disconnect combustion air intake from the burner box and inspect internally using a flashlight to make sure no foreign material has collected in the tubes and that there is no obstruction around the air intake openings. Clean any foreign materials. Inspect any joints to make sure they are completely sealed. See also Section 17.
- **Venting System:** Disconnect vent pipe and inspect internally using a flashlight to make sure no foreign material has collected in the pipes. Check the external vent cap and make sure that there is no obstruction around the exhaust openings. Clean any foreign materials. Inspect any joints to make sure they are completely sealed. See also Section 16.
- **Gas lines:** Make sure that the gas lines are not leaking. Check the gas connection to the heater for any signs of damage, fatigue or corrosion. If there are any signs of damage to the gas connection or leaks found in the gas piping, immediately stop using the heater until the gas pipe and connections have been repaired or replaced. Check that the gas lines are not bearing the weight of the heater. See also Section 13.
- **Burner Box:** In order to extend the longevity of the heater, the heat exchanger tube and the burner must be level. Check that the burner box is level, use the turnbuckle on the burner suspension eyebolt to adjust the level of the burner. See also Section 9.
- **Burner sight glass:** Check that the burner sight glass is clean and that the glass is sealed against the housing door. If there any signs of distortion, the sight glass must be replaced. See section 20 for sight glass location.
- **Blower wheel and housing:** Check that the blower wheel spins freely, blow out any dust or dirt with compressed air. See section 20 for blower location.
- **Electrode condition:** Visually check that the electrode gap is maintained at 1/8" and that the tips of the flame sensor and spark electrode are free from deposits. Clean off any deposits. Check that the electrode ceramic is free from cracks. See Section 23.1
- **Suspension system:** Check that the suspension system is holding the heater level. Make sure that the heater is hanging securely, look for any evidence where the heater may have been hit accidentally and tighten any loose hanging points. Check that S hooks are closed. Check that there is no evidence of wear on the chain at the connection to the heater and at the ceiling.
- **Tube Integrity Safety System:** Check that the tension of the tube integrity safety system is maintained at 11". Adjust tension if necessary. See section 12.1
- **Main Burner and Orifice:** Check the Main burner and orifice, remove any dirt or debris including spider webs. See Section 23.1

22.0) TROUBLESHOOTING GUIDE

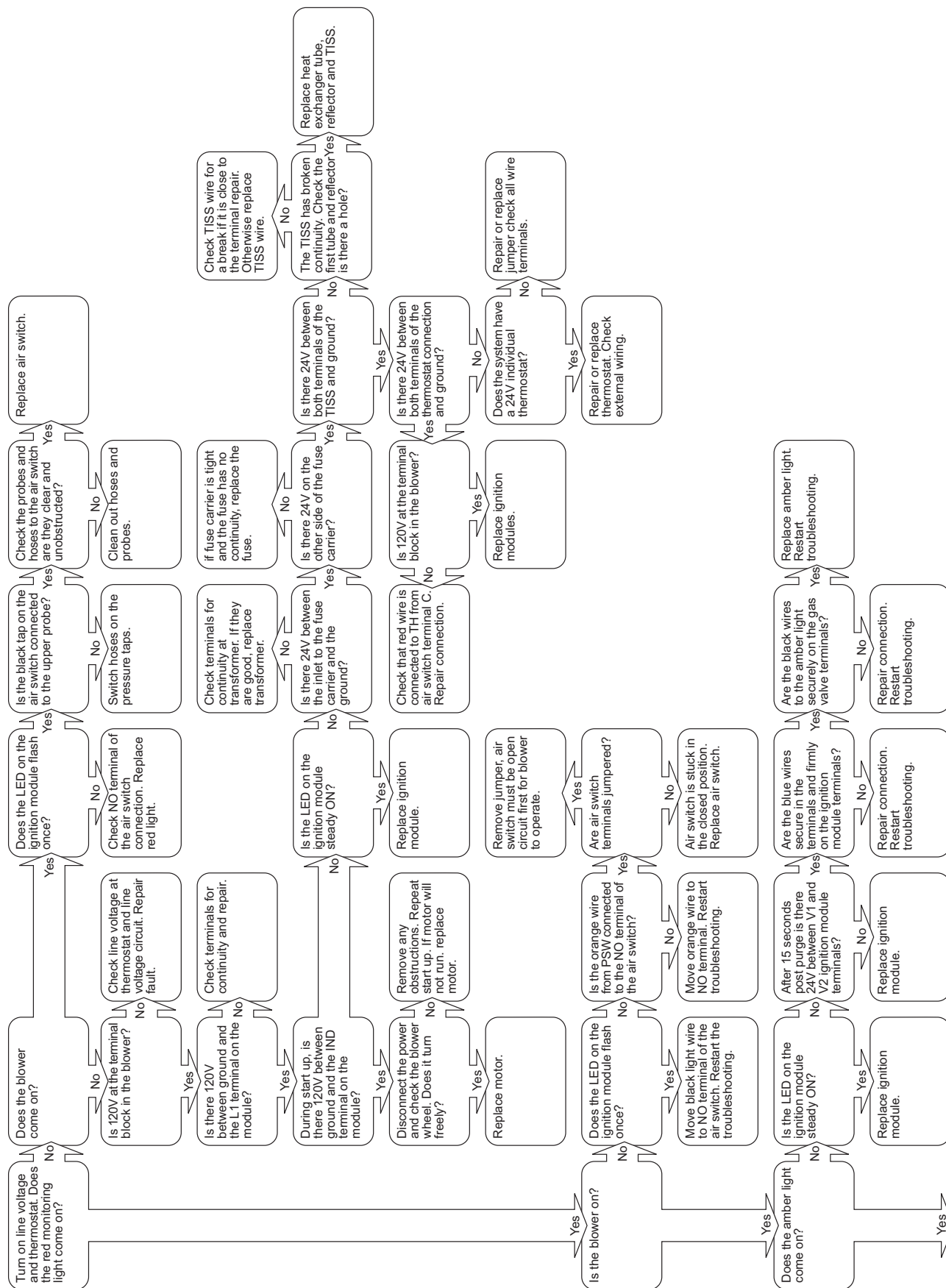

Troubleshooting continued on the next page.

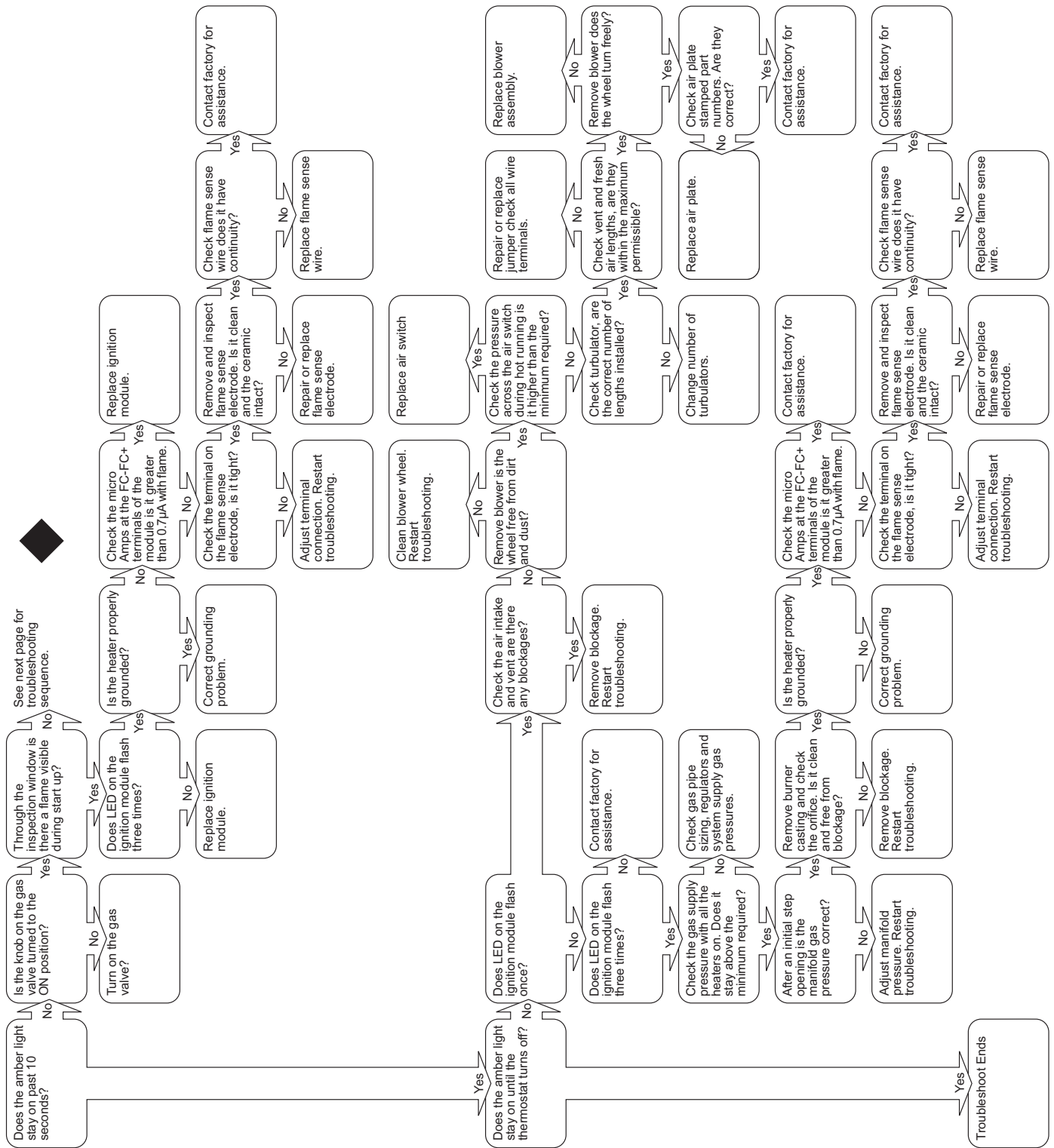

See next page for troubleshooting sequence.

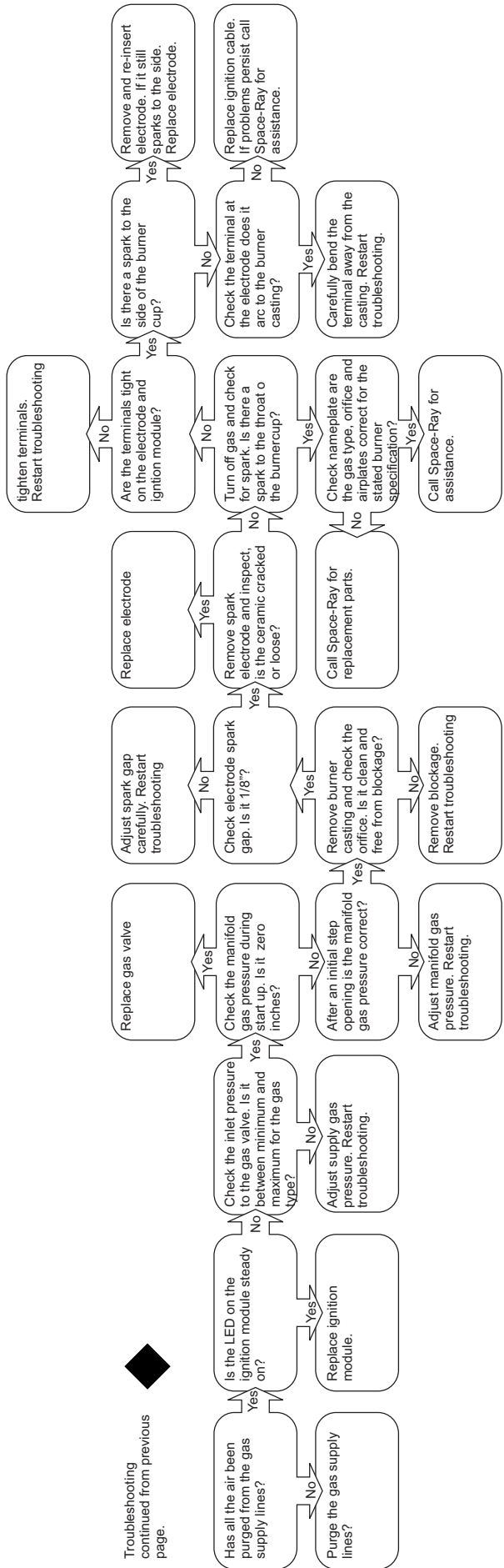

Troubleshooting continued from previous page.

23.0) REPLACING PARTS

⚠ WARNING

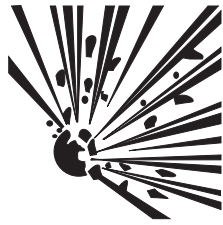
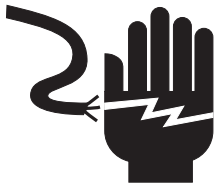

ELECTRIC SHOCK & EXPLOSION HAZARD

Disconnect electrical power and gas supply before servicing.

Failure to do so may result in death or serious injury.

Only use genuine Space-Ray replacement parts. Parts are available from the factory for replacement by a licensed person. Refer to the Replacement Parts Guide in Section 25 for all replacement parts.

23.1) REMOVAL OF MAIN BURNER AND ELECTRODES

The main burner can be inspected without removing the burner housing from the heat exchanger tube.

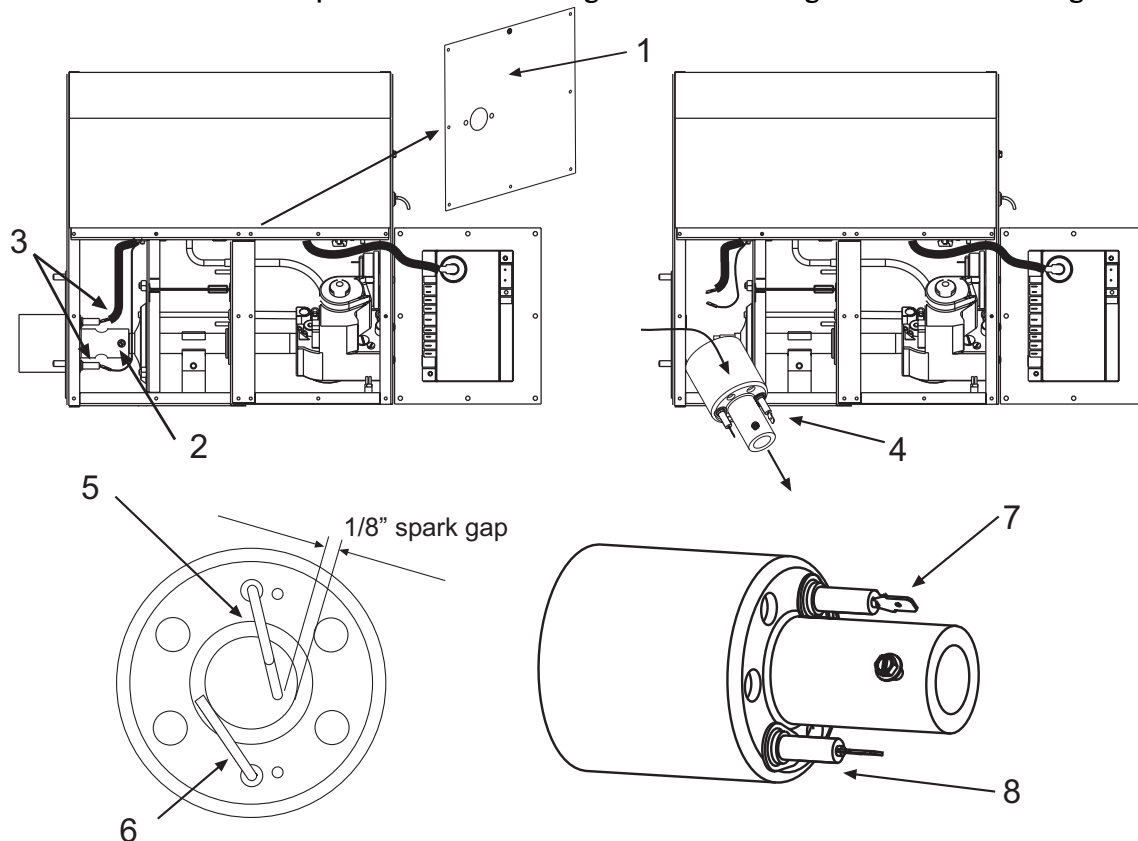

1. Disconnect electrical supply and Remove cover 1.
2. Remove screw securing burner casting to the gas manifold.
3. Disconnect Spark lead and sensing wire.
4. Pull burner forward from the gas manifold and then out through the side of the box as shown.
5. Check that the spark gap is 1/8" between the electrode and the burner casting as shown. Spark electrode should be clean and free from debris.
6. Flame sensor should be clean and free from debris.
7. Check ceramic on the spark electrode, for replacement into the box the spark electrode is the 1/4" terminal which connects to the spark lead.
8. Check ceramic on flame sense electrode, for replacement into the box the flame sense electrode is the 3/16" terminal which connects to the violet wire. (in some models the terminal is 1/4" painted violet)

23.2) REMOVAL OF GAS VALVE AND MANIFOLD ASSEMBLY

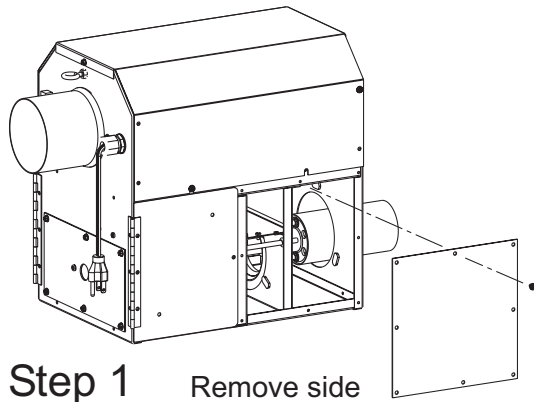

Step 1 Remove side access panel.

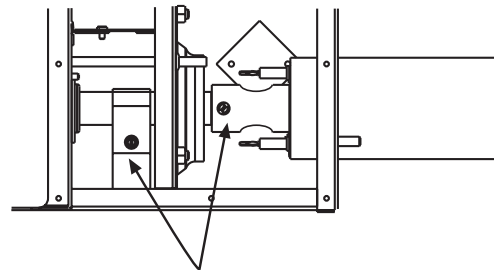

Step 2 Loosen screws from manifold clamp and burner assembly.

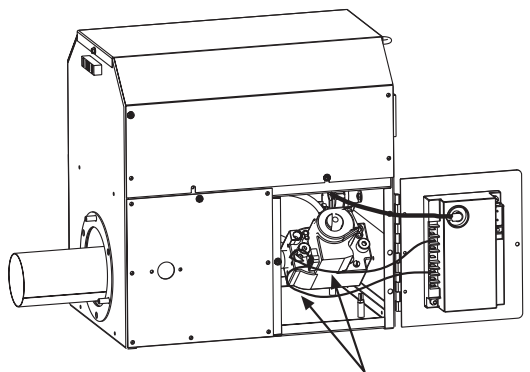

Step 3 Open hinged access panel and disconnect wires from gas valve.

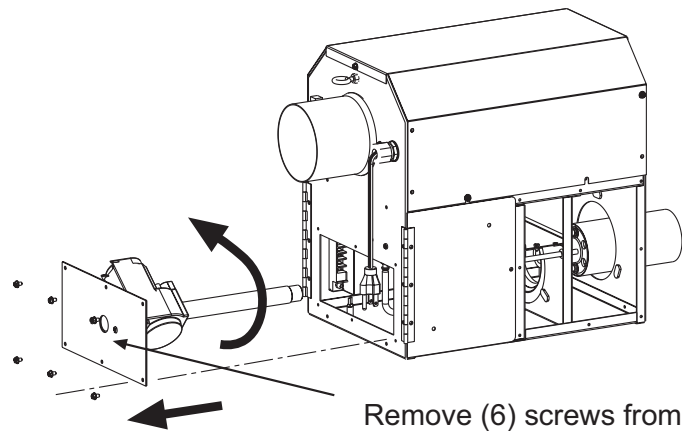

Step 4 Remove (6) screws from end panel. Rotate gas valve and manifold assembly slightly counter-clockwise and slide out from housing.

23.3) AIR SWITCH PRESSURE CHECK

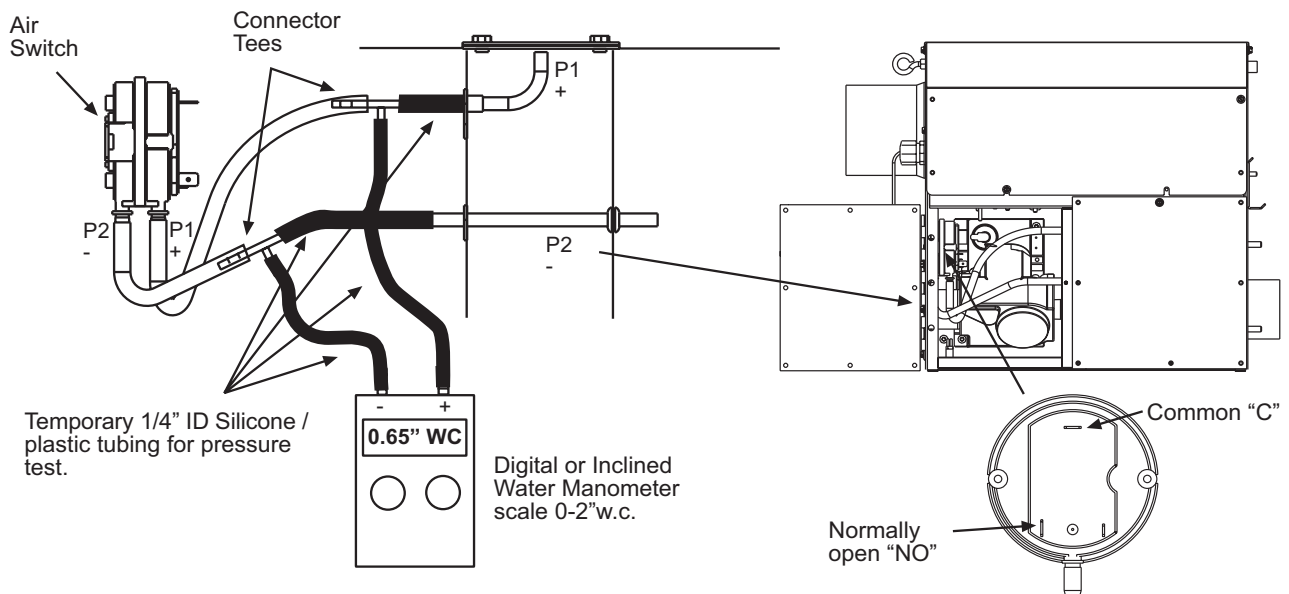

1. Open hinged access panel.
2. Add tubing to connect the air switch tubing P1 + and P2 - with the connector tees and the probes P1+ and P2+.
3. Connect plastic tubing of a digital or inclined water manometer with a 0-2" scale onto the connector tees.
4. Turn heater on and wait until blower motor is activated.
5. Observe air pressure from manometer. This should be higher than the set point indicated below for correct operation.

Model	Operating Pressure
PTS/U 40	0.98" W.C. Hot
PTS/U 50	0.98" W.C. Hot
PTS/U 75	0.70" W.C. Hot
PTS/U 100	0.70" W.C. Hot
PTS/U 125	0.39" W.C. Hot
PTS/U 150	0.39" W.C. Hot
PTS/U 175	0.39" W.C. Hot
PTS/U 200	0.39" W.C. Hot

All pressures are with the heater in operation for at least 15 minutes.

23.4) IGNITION SYSTEM CHECKS

TO CHECK FLAME SENSOR CIRCUIT.

Flame current is the current which passes through the flame from the sensor to ground. The minimum flame current necessary to keep the system from lockout is 0.7 microamps.

- a) Turn off heater at thermostat.
- b) Connect a meter (dc microammeter scale) in series with the ground lead as shown in the diagram. Connect the meter as follows:
 - Connect the black (negative) meter lead to the electronic control FC- terminal.
 - Connect the red (positive) meter lead to the electronic control FC+ terminal.
- c) Restart the system and read the meter. The flame sensor current must be steady and measure at least 0.7 microamps.
- d) If the meter reads less than the minimum or if reading is unsteady:
 - Make sure burner flame is capable of providing a good rectification signal.
 - Make sure fasteners securing igniter/sensor are tightened to assure correct positions. DO NOT relocate igniter/sensor.
 - Check for excessive (over 1000°F) temperature at ceramic insulator on flame sensor. Excessive temperature can cause short to ground. DO NOT relocate igniter/sensor.
 - Check for cracked ceramic insulator, which can cause short to ground, and replace sensor if necessary.
 - Make sure that electrical connections are clean and tight. Replace damaged wire.
- e) If the meter reads below "0" on the scale, meter leads are reversed. Disconnect power and reconnect meter leads for proper polarity.
- f) Remove microammeter. Return system to normal operation.

IGNITION MODULE DIAGNOSTICS

Flame Fault

If at any time the main valve fails to close completely and maintains a flame, the full time flame sense circuit will detect it and energize the combustion blower. Should the main valve later close completely removing the flame signal, the combustion blower will power off following the post purge period.

Fault Conditions

Error Mode	LED Indication
Internal Control Failure	Steady On
Air Flow Fault	1 Flash
Gas valve failure (stuck open)	2 Flashes
Ignition Lockout	3 Flashes

The LED located on the ignition module will flash ON for $\frac{1}{4}$ second, then OFF for $\frac{1}{4}$ second during a fault condition. The pause between fault codes is 3 seconds.

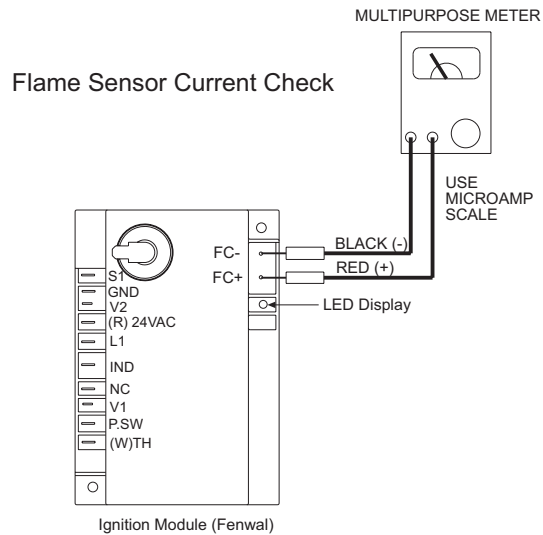

24.0) INSTALLATION DATA

Date of Installation: _____ # of Heaters in System: _____

Serial No. _____

Model: **PTS or PTU** _____

N = Natural Gas

L = Propane Gas

25.0 REPLACEMENT PARTS GUIDE – BURNER BOX

Item No.	Part No.	Description	Qty.
Fasteners			
1	02295040	PHTCS #6-32 x 3/8"	3
1a	02266010	Speed Clips (for air inlet plate)	2
2	02261030	HHTCS #8-32 x 3/8" (green coated)	1
3	02242050	PHTCS #8-32 x 3/8"	5
4	02215020	HHMS #8-32 x 3/4"	2
5	02167010	Locknut 1/4-20 Keps	5
5a	02309000	Eyebolt 1/4-20 x 2"	1
6	02167040	Locknut #8-32 Keps	9
7	02212020	HWHSMS #8 x 1/2" "B" Point (typical all access panels)	45
8	02132020	Rivet 1/8"	14

Housing Components			
9	44139990	Housing Assembly (welded)	1
9a	44140111	Valve Holder Plate	1
10	44140000	Access Panel (top)	1
11	44140040	Access Panel (hinged)	2
11a	02201070	Hinge 1-1/16" x 6"	2
12	44140058	Access Panel (LH burner end) –with sight glass-	1
13	44140090	Access Panel (RH burner end)	1
14	4414006x	Combustion Air Plate (see size requirements in section 5.0)	1

Burner Components			
15	42700500	Burner, Investment Casting - Machined	1
16	44146030	Manifold Support Bracket	1
17	44146040	Manifold Support Clamp	1
17a	44146050	Manifold Extension Bracket	1
18	30703000	Blower Assembly	1
19	30632500	Spark Module - Fenwal-24V #35-615935-197	1
20	30702010	Flame Sensor #PSE-GF24	1
21	30702020	Electrode #PSE-GF25	1
22	30281000	Terminal Block #EK-204	1
22a	30717000	Terminal Block #EF-10001 (24V thermostat connection)	1
22b	30713000	Fuse Holder	1
22c	30202000	Fuse 1/4 x 1-1/4" (2 amp)	1
23	30279000	Transformer 120v-24V 20VA	1
24	02175020	Strain Relief #SR-6P3-4 (ignition cable)	1
25	02175060	Strain Relief #SR-2M-1 (flame sensor wire)	1
26	30514020	Grommet .250ID #739 (air sensing tube)	1
26a	30512020	Split Bushing #2871 (misc. wiring, ignition cable, sensor wire)	2
27	30700040	Grommet, Pipe Sealing 1/2" #63595K34	1
28	42447000	Sight Glass (1-5/8" square plexiglass)	1
29	42744079	Air Sensing Tube Asm. (straight) 1/4"od	1
30	42744069	Air Sensing Tube Asm. (90 deg bend) 1/4"	1
31	30635030	Cord Connector 1/2" #LPCG50	1
32	03988100	Plastic Vacuum Air Tube 10" (P2- to static pressure point)	1
33	03988100	Plastic Vacuum Air 10" (P1+ to total pressure point)	1
34	43563040	Supply Cord -Flat (SPT-1 18/3 x 72" long)	1
35	42709000	Shield, Terminal Block	1
36	42395010	Gasket, Blower	1

37	03946010	Sealing Strip 1/8" x 3/8" wide (access panels) -not shown-	Ft.
38	42752250	Air Inlet Screen	1
38a	30504040	Starting Collar (combustion air inlet)	1
39	30701240	Ignition Cable - Female (2) 1/4" QC x 24"lg #PSE-GF23 -not shown-	1
40	44145060	Manifold Pipe – 6-1/4"lg	1
40a	03333140	Pipe Nipple – 4"lg	1
41	30333070	Gas Valve #VR8205P-2408 (natural gas)	1
41a	30333080	Gas Valve #VR8205P-2416 (propane gas)	1
42			
42a			
43	03259xxx	Main Burner Orifice #7/16-27 (see size requirements in section 5.0)	1
44	42741150	Air Restrictor Plate 2-3/4"	1
45	44151010	Burner Screen Sub-Assembly (PTS/PTU 200 only)	1
46	42398030	Monitoring Light – Amber (gas valve operation)	1
47	42398150	Monitoring Light – Red (air switch operation)	1
48	30186250	Air Switch (set point @ .93"WC) PTS/PTU40 & 50	1
48a	30186260	Air Switch (set point @ .65"WC) PTS/PTU75 & 100	1
48b	30186270	Air Switch (set point @ .34"WC) PTS/PTU125,150,175 & 200	1

Labels/Manual			
49	42848000	Label, Nameplate (Space-Ray)	1
50	42013000	Label, Logo (Space-Ray) (Not Shown)	1
51	43344070	Label, Clearances to Combustibles	1
52	42874020	Label, Wire Connection Diagram	1
53			
54	42875000	Label, Warning (installation/configuration/chemical)	1
55	43269010	Label, 24V Thermostat Connection	1
56	43269020	Label, TISS Connection	1
57	43269030	Label, Eyebolt Suspension Warning	1
58	43269040	Label, Gas Valve in "OFF" Position	1
59	43269050	Label, Burner Warning (access panel must remain closed)	1
60	43344110	Label, Flex Gas Connector	1
61	42785020	Label, Ladder Wiring Connection	1
62	42834000	Label, 120V Caution	1
63	42922030	Label, Sidewall Venting	1
64	43343330	Installation & Operation Manual (Not Shown)	1

Tube Integrity Safety Switch (TISS) Components			
65	44175000	Retainer clamp	1
66	30519020	Spring	1
67	30736000	Thimble	1
68	44176010	TISS replacement assembly	1

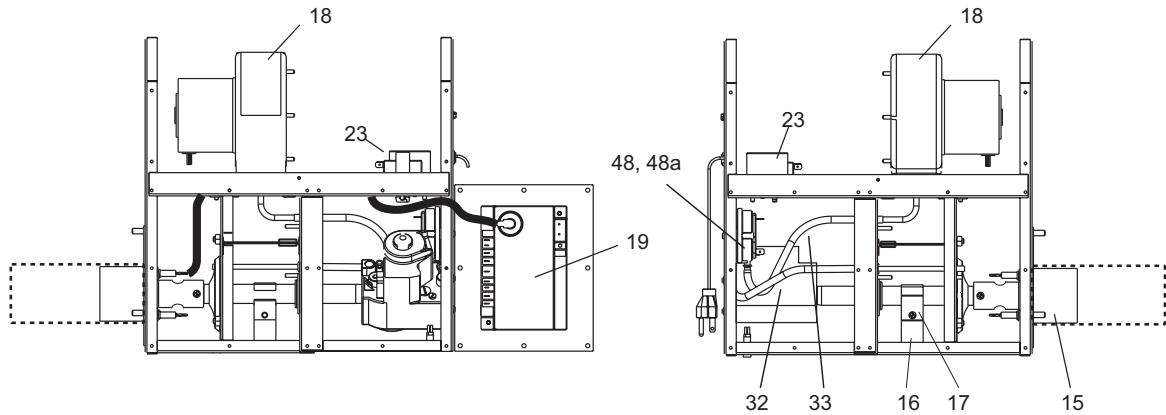
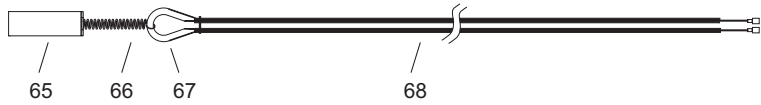
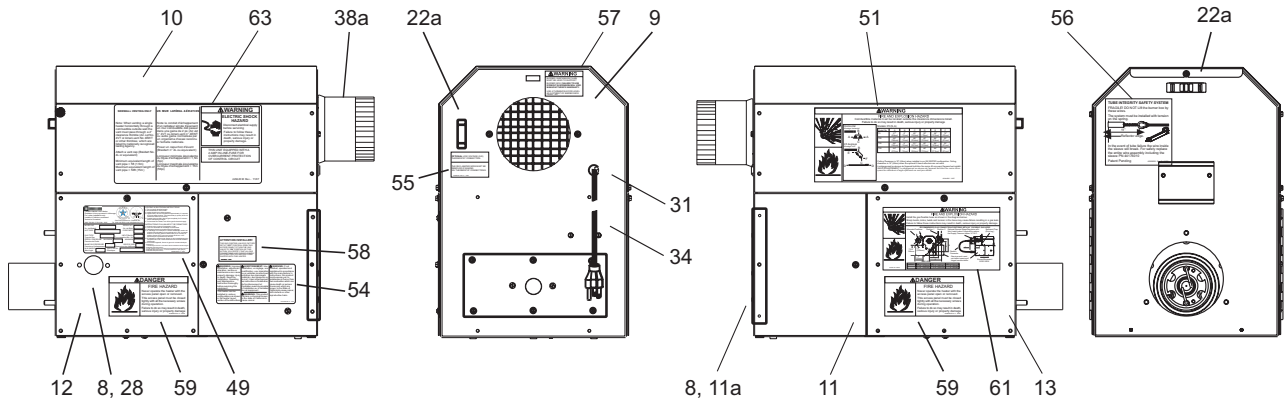
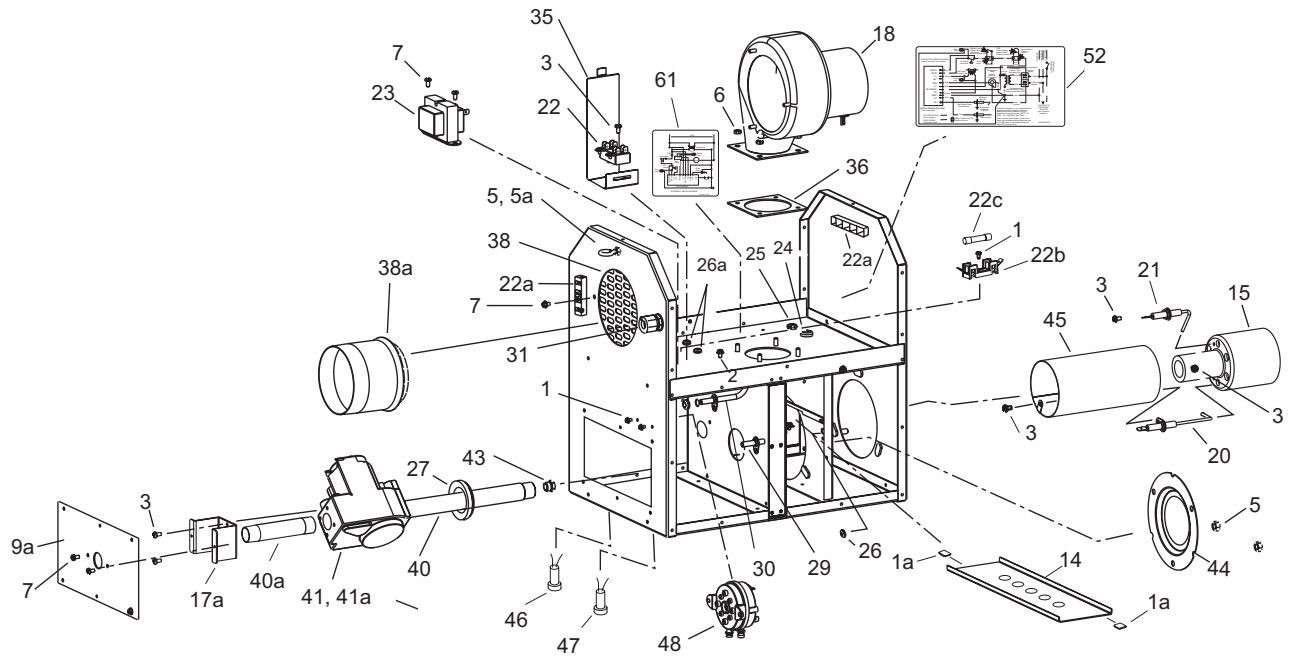

BODY COMPONENTS		
ITEM	PART NO.	DESCRIPTION
1	02266010	Reflector Speed Clip
2	43980010	Wire Hanger
3	42873000	"U" Bolt Clamp, 4" OD Tube
3a	02127110	5/16-18 Hex Nut (2 per "U" Bolt)
4	43318000	Tube Support/Hanger Bracket, 13"
5	43319050	Reflector, 4'-11½" long (5' section only; 1 per 5 ft. body section)
6	43319100	Reflector, 9'-11½" long (10' section only; 1 per 10 ft. body section)
7	43320000	End Reflector (optional)
8	43342000	Corner Reflector Package (optional)
9	42921000	Tube Flange Gasket
10*	44028170	10' Tube Assembly Kit, 4" OD, ATC steel with one 6-hole flange (start tube)
10a**	44028030	10' Tube Assembly Kit, 4" OD, ALC steel with one 24-hole flange (start tube)
11	44028100	10' Tube Assembly Kit, 4" OD, HRS steel without flanges (extension tube & exhaust tube)
11a	44028060	10' Tube Assembly Kit, 4" OD, ALC steel without flanges (extension tube & exhaust tube)
12	44028120	5' Tube Assembly Kit, 4" OD, HRS steel without flanges (extension tube & exhaust tube)
12a	44028010	5' Tube Assembly Kit, 4" OD, ALC steel without flanges (extension tube & exhaust tube)
13	43208010	4" O.D. Elbow Package
14	02189020	#10 x ½" Self-Drilling Screw
15	30462980	4" OD Tube Compression Coupling w/bolts
16	43208020	4" OD U-Bend (Required for PTU Only)
17	43488000	U-Bend Reflector (PTU Option)
18	30504500	Flue Adapter Collar
19	44152240	Turbulator (see specifications section 5.0 for quantities)

* Required on 40ft, 50ft, 60ft and 70ft systems for mounting of control box.

** Required on 10ft, 20ft and 30ft systems for mounting of control box.

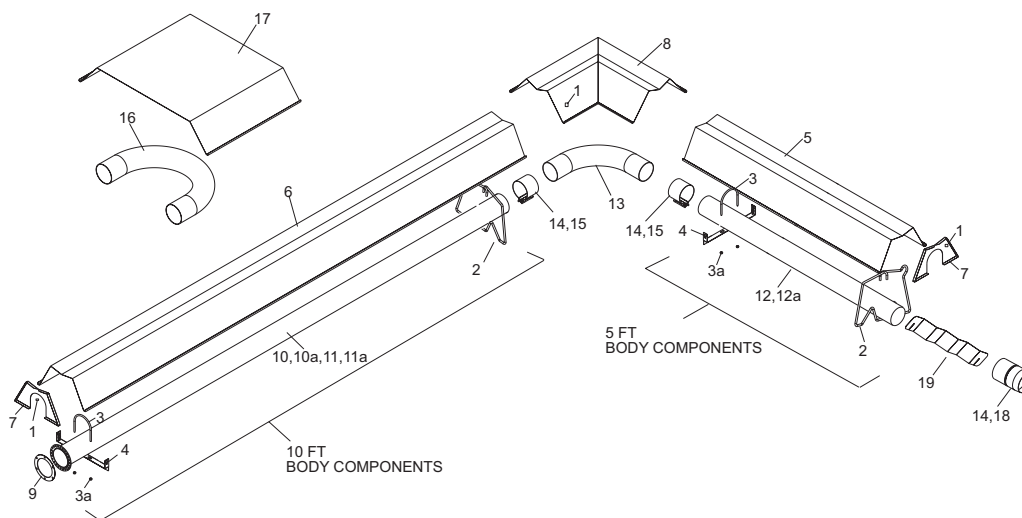

ALL ILLUSTRATIONS ARE INTENDED TO GIVE THE GENERAL IMPRESSION OF UNITS ONLY. OTHER COMBINATIONS OF 5 FT. AND 10 FT. SECTIONS, AND ONES WITH OR WITHOUT THE ELBOW PACKAGE ARE POSSIBLE. PLEASE CONSULT WITH YOUR Space-Ray SALES REPRESENTATIVE. WE RESERVE THE RIGHT TO ALTER ANY SPECIFICATION WITHOUT NOTICE.

Free Manuals Download Website

<http://myh66.com>

<http://usermanuals.us>

<http://www.somanuals.com>

<http://www.4manuals.cc>

<http://www.manual-lib.com>

<http://www.404manual.com>

<http://www.luxmanual.com>

<http://aubethermostatmanual.com>

Golf course search by state

<http://golfingnear.com>

Email search by domain

<http://emailbydomain.com>

Auto manuals search

<http://auto.somanuals.com>

TV manuals search

<http://tv.somanuals.com>