

# 12" Variable Speed Wood Lathe (Model 46-700)

INSTRUCTION MANUAL



Shown with Accessory  
46-705 Stand

DATED 8-1-91

PART NO. 434-08-651-0001  
©Delta International Machinery Corp. 1991

 **DELTA**

# TABLE OF CONTENTS

SAFETY RULES .....	3
ADDITIONAL SAFETY RULES FOR WOOD LATHES .....	4
UNPACKING AND CLEANING .....	5
ASSEMBLING AND SETTING UP LATHE .....	5
CONNECTING LATHE TO POWER SOURCE	
Power Connections .....	8
Grounding Instructions .....	8
FASTENING LATHE TO SUPPORTING SURFACE .....	9
OPERATING CONTROLS AND ADJUSTMENTS	
Starting And Stopping Lathe .....	9
Locking Switch In The "OFF" Position .....	9
Spindle Speeds .....	10
Repositioning Headstock For Outboard Turning .....	10
Tool Rest .....	11
Tailstock .....	11
Headstock Spur Center .....	12
Tailstock Cup Center .....	12
OPERATION	
Lathe Tools .....	13
How To Turn Spindles .....	13
Centering The Work .....	14
Mounting The Work .....	14
Tool Rest Position .....	15
Roughing A Cylinder .....	15
Position of Hands .....	16
Smoothing A Cylinder .....	16
Using The Parting Tool .....	16
Squaring An End .....	17
Cutting A Shoulder .....	17
Cutting Small Beads .....	18
Vee Grooves .....	18
Long Cuts .....	19
Cove Cuts .....	19
Square Sections .....	20
Faceplate Turning .....	21
Mounting Work To Faceplate .....	21
Inboard Faceplate Turning .....	21
Outboard Faceplate Turning .....	22
Hollow Tailstock .....	23
MAINTENANCE	
Replacing Variable Speed Drive Belt .....	24
AUTHORIZED SERVICE STATIONS .....	26
PARTS, SERVICE OR WARRANTY ASSISTANCE .....	28
WARRANTY .....	28

# SAFETY RULES

As with all machinery there are certain hazards involved with operation and use of the machine. Using the machine with respect and caution will considerably lessen the possibility of personal injury. However, if normal safety precautions are overlooked or ignored, personal injury to the operator may result.

This machine was designed for certain applications only. Delta Machinery strongly recommends that this machine NOT be modified and/or used for any application other than for which it was designed. If you have any questions relative to its application DO NOT use the machine until you have written Delta Machinery and we have advised you.

DELTA INTERNATIONAL MACHINERY CORP.  
MANAGER OF TECHNICAL SERVICES  
246 ALPHA DRIVE  
PITTSBURGH, PENNSYLVANIA 15238  
(IN CANADA: 644 IMPERIAL ROAD, GUELPH, ONTARIO N1H 6M7)

## WARNING: FAILURE TO FOLLOW THESE RULES MAY RESULT IN SERIOUS PERSONAL INJURY

- 1. FOR YOUR OWN SAFETY, READ INSTRUCTION MANUAL BEFORE OPERATING THE TOOL.** Learn the tool's application and limitations as well as the specific hazards peculiar to it.
- 2. KEEP GUARDS IN PLACE** and in working order.
- 3. ALWAYS WEAR EYE PROTECTION.**
- 4. GROUND ALL TOOLS.** If tool is equipped with three-prong plug, it should be plugged into a three-hole electrical receptacle. If an adapter is used to accommodate a two-prong receptacle, the adapter lug must be attached to a known ground. Never remove the third prong.
- 5. REMOVE ADJUSTING KEYS AND WRENCHES.** Form habit of checking to see that keys and adjusting wrenches are removed from tool before turning it "on."
- 6. KEEP WORK AREA CLEAN.** Cluttered areas and benches invite accidents.
- 7. DON'T USE IN DANGEROUS ENVIRONMENT.** Don't use power tools in damp or wet locations, or expose them to rain. Keep work area well-lighted.
- 8. KEEP CHILDREN AND VISITORS AWAY.** All children and visitors should be kept a safe distance from work area.
- 9. MAKE WORKSHOP CHILDPROOF** - with padlocks, master switches, or by removing starter keys.
- 10. DON'T FORCE TOOL.** It will do the job better and be safer at the rate for which it was designed.
- 11. USE RIGHT TOOL.** Don't force tool or attachment to do a job for which it was not designed.
- 12. WEAR PROPER APPAREL.** No loose clothing, gloves, neckties, rings, bracelets, or other jewelry to get caught in moving parts. Nonslip foot wear is recommended. Wear protective hair covering to contain long hair.
- 13. ALWAYS USE SAFETY GLASSES.** Wear safety glasses (must comply with ANSI Z87.1). Everyday eye-glasses only have impact resistant lenses; they are not safety glasses. Also use face or dust mask if cutting operation is dusty.
- 14. SECURE WORK.** Use clamps or a vise to hold work when practical. It's safer than using your hand and frees both hands to operate tool.
- 15. DON'T OVERREACH.** Keep proper footing and balance at all times.
- 16. MAINTAIN TOOLS IN TOP CONDITION.** Keep tools sharp and clean for best and safest performance. Follow instructions for lubricating and changing accessories.
- 17. DISCONNECT TOOLS** before servicing and when changing accessories such as blades, bits, cutters, etc.
- 18. USE RECOMMENDED ACCESSORIES.** The use of improper accessories may cause hazards.
- 19. AVOID ACCIDENTAL STARTING.** Make sure switch is in "OFF" position before plugging in power cord.
- 20. NEVER STAND ON TOOL.** Serious injury could occur if the tool is tipped or if the cutting tool is accidentally contacted.
- 21. CHECK DAMAGED PARTS.** Before further use of the tool, a guard or other part that is damaged should be carefully checked to ensure that it will operate properly and perform its intended function - check for alignment of moving parts, binding of moving parts, breakage of parts, mounting, and any other conditions that may affect its operation. A guard or other part that is damaged should be properly repaired or replaced.
- 22. DIRECTION OF FEED.** Feed work into a blade or cutter against the direction of rotation of the blade or cutter only.
- 23. NEVER LEAVE TOOL RUNNING UNATTENDED. TURN POWER OFF.** Don't leave tool until it comes to a complete stop.
- 24. DRUGS, ALCOHOL, MEDICATION.** Do not operate tool while under the influence of drug, alcohol or any medication.
- 25. MAKE SURE TOOL IS DISCONNECTED FROM POWER SUPPLY** while motor is being mounted, connected or reconnected.
- 26. WARNING:** The dust generated by certain woods and wood products can be injurious to your health. Always operate machinery in well ventilated areas and provide for proper dust removal. Use wood dust collection systems whenever possible.

# ADDITIONAL SAFETY RULES FOR WOOD LATHES

1. **WARNING: DO NOT** operate your lathe until it is completely assembled and installed according to the instructions.
2. **IF YOU ARE NOT** thoroughly familiar with the operation of wood lathes, obtain advice from your supervisor, instructor or other qualified person.
3. **MAKE SURE** wiring codes and recommended electrical connections are followed and that the machine is properly grounded.
4. **NEVER** turn the lathe "ON" before clearing the lathe bed of all objects (tools, scraps of wood, etc.).
5. **EXAMINE** set-up carefully before turning on the power.
6. **MAKE SURE** tool rest height is adjusted properly.
7. **MAKE SURE** tool rest is adjusted as close to the workpiece as possible.
8. **ROTATE** workpiece by hand to check clearance before engaging power.
9. **NEVER** adjust the tool rest while workpiece is turning.
10. **REMOVE** the tool rest before sanding or polishing.
11. **WHEN TURNING** between centers **MAKE SURE** the tailstock center is snug against the workpiece and locked. The tailstock center should be lubricated if it is not a ball bearing center.
12. **NEVER** drive workpiece into drive center when drive center is in headstock. Set drive center into workpiece with a soft mallet prior to installing it into the headstock.
13. **NEVER** loosen tailstock spindle or tailstock while workpiece is turning.
14. **WHEN** faceplate turning, **MAKE SURE** workpiece is securely fastened to the faceplate and that appropriate size faceplate is used to properly support workpiece.
15. **WHEN** faceplate turning, **MAKE SURE** the screw fasteners do not interfere with the turning tool at the finished dimension of the workpiece.
16. **ROUGH CUT** workpiece as close as possible to finished shape before installing on faceplate.
17. **TIGHTEN** all clamp handles before operating.
18. **EXAMINE** workpiece for flaws and test glue joints before placing workpiece in lathe.
19. **WHEN** roughing off, **DO NOT** jam tool into workpiece or take too big a cut.
20. **USE** lowest speed when starting a new workpiece.
21. **ALWAYS** operate the lathe at the recommended speeds. Consult owners manual for suggested speeds.
22. **MAKE** all adjustments with the power "OFF." Change speed only when lathe is running.
23. **DISCONNECT** lathe from power source when making repairs.
24. **DISCONNECT** lathe from power source and clean the machine before leaving it.
25. **MAKE SURE** the work area is cleaned before leaving the machine.
26. **SHOULD** any part of your lathe be missing, damaged or fail in any way, or any electrical component fail to perform properly, shut off switch and remove plug from the power supply outlet. Replace missing, damaged or failed parts before resuming operation.
27. **CAUTION:** To reduce the risk of injury, **ALWAYS** wear safety glasses and face and head protection when operating wood lathe.
28. **ADDITIONAL INFORMATION** regarding the safe and proper operation of this product is available from the National Safety Council, 444 N. Michigan Avenue, Chicago, IL 60611 in the Accident Prevention Manual for Industrial Operations and also in the Safety Data Sheets provided by the NSC. Please also refer to the American National Standards Institute ANSI O1.1 Safety Requirements for Woodworking Machines and the U.S. Department of Labor OSHA 1910.213 Regulations.

# UNPACKING AND CLEANING

Your new Wood Lathe is shipped complete in one carton. Carefully unpack the wood lathe and all loose items from the carton. Remove the protective coating from the lathe bed and all unpainted parts. This coating may be removed with a soft cloth moistened with kerosene (do not use acetone, gasoline, or lacquer thinner for this purpose). After cleaning cover the lathe bed with a good quality paste wax.

**WARNING: FOR YOUR OWN SAFETY, DO NOT CONNECT THE LATHE TO THE POWER SOURCE UNTIL THE MACHINE IS COMPLETELY ASSEMBLED AND YOU HAVE READ AND UNDERSTAND THE ENTIRE OWNERS MANUAL.**

## ASSEMBLING AND SETTING UP LATHE

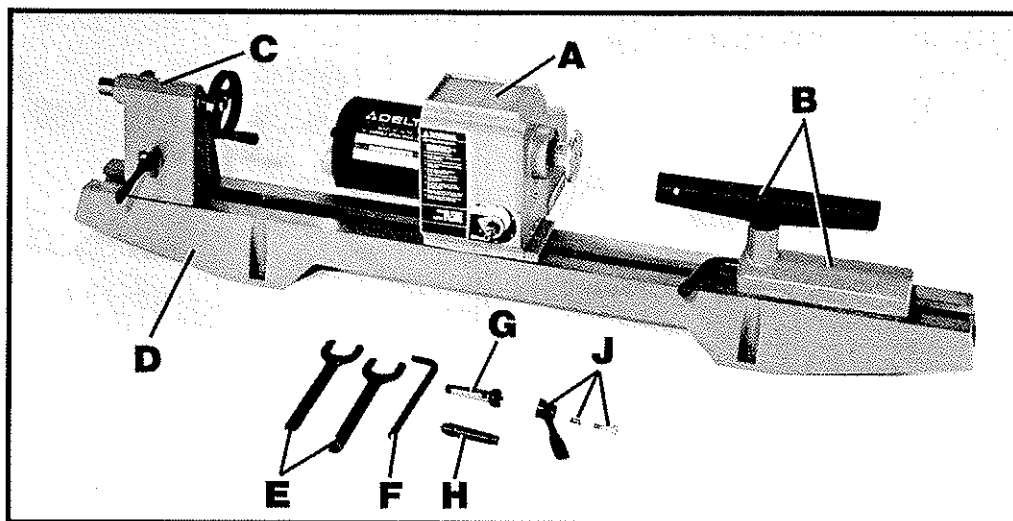

Fig. 2

1. Fig. 2, illustrates the lathe and all loose items after they are removed from the carton. The headstock (A), tool rest (B) and tailstock (C) are mounted to the lathe bed (D). Loose items shipped with your lathe are the two spindle wrenches (E), headstock positioning wrench (F), headstock spur center (G), tailstock cup center (H) and variable speed handle, spring and screw (J).

2. Assemble the handle, spring and screw (J) to the end of the variable speed control shaft, as shown in Fig. 3.

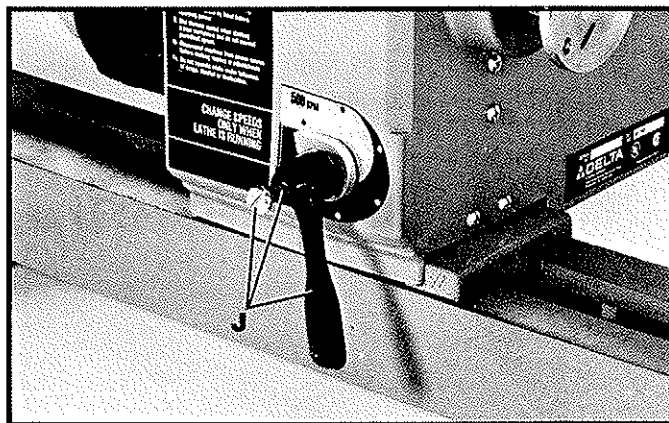

Fig. 3

3. Loosen tailstock locking lever (K) Fig. 4, and remove tailstock (C) from left end of lathe bed.

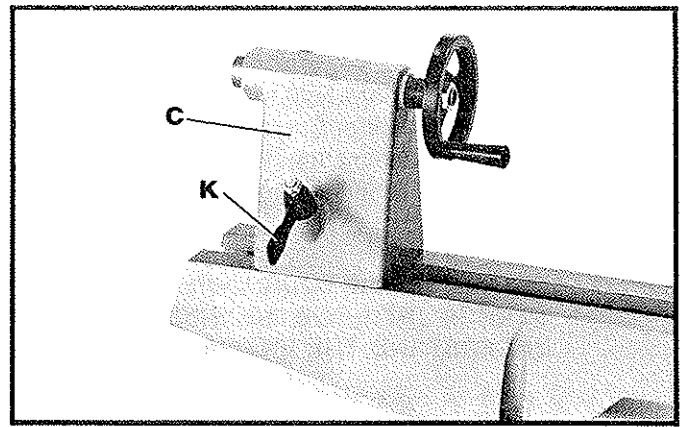

Fig. 4

4. Using the headstock positioning wrench (F) Fig. 5, loosen screw (L) located directly underneath headstock (A) just enough to allow the headstock (A) to slide along the lathe bed. **NOTE:** Do not overly loosen screw (L).

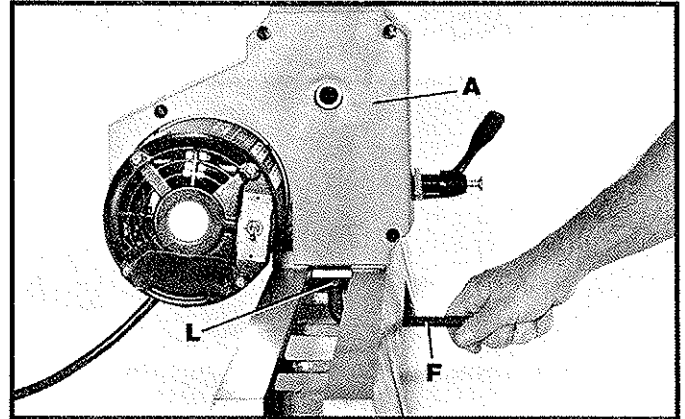

Fig. 5

5. Slide headstock (A) Fig. 6, to the left end of lathe bed (D), as shown, and tighten headstock locking screw that was loosened in **STEP 4**.

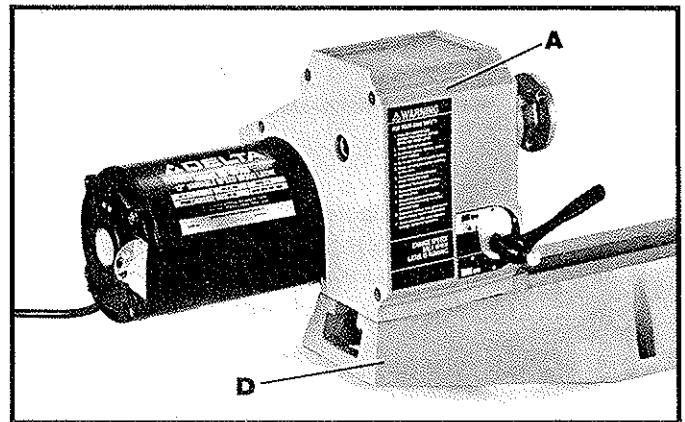

Fig. 6

6. Using the two spindle wrenches (E) Fig. 7, remove faceplate (M) from headstock spindle.

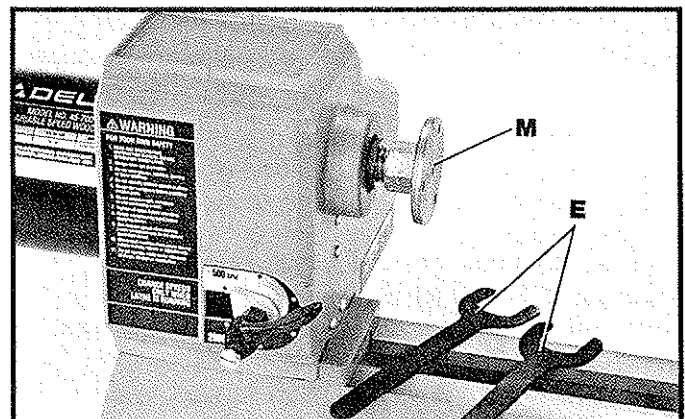

Fig. 7

7. Lift up tool rest base locking lever (N) Fig. 8, and loosen tool rest locking lever (O).

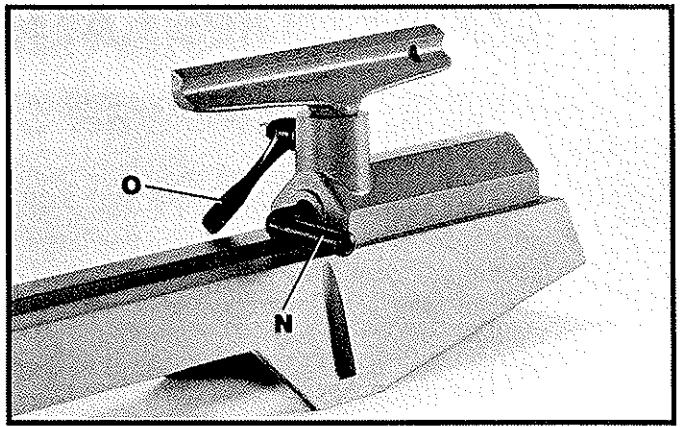

Fig. 8

8. Reposition tool rest base (P) and tool rest (Q) on lathe bed as shown in Fig. 9, and tighten locking levers (N) and (O).

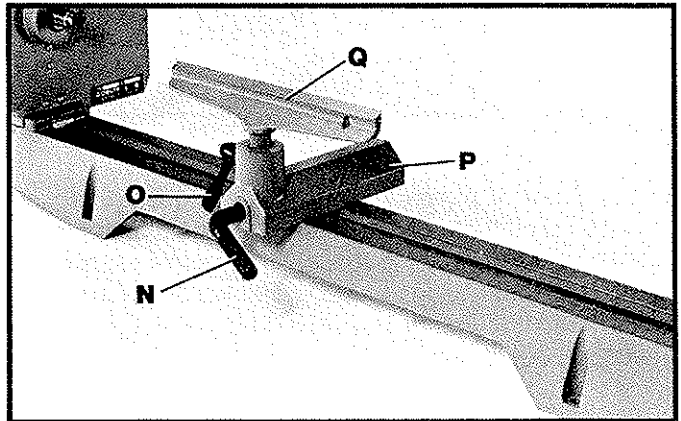

Fig. 9

9. Loosen tailstock locking lever (K) Fig. 10, and slide tailstock (C) onto right end of lathe bed as shown. **NOTE:** Make sure clamp (R) is in position underneath lathe bed.

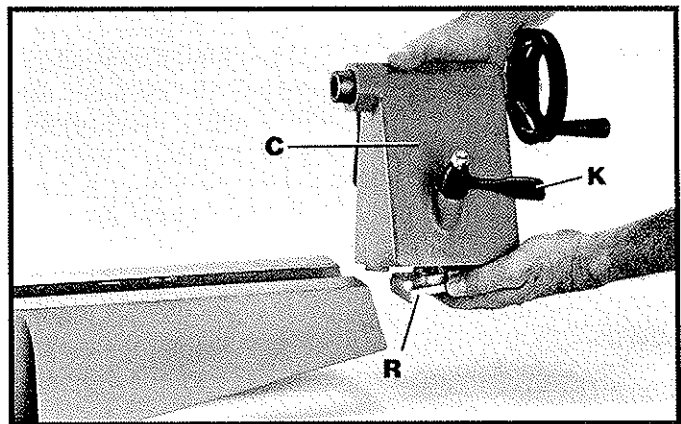

Fig. 10

10. Fig. 11, illustrates tailstock (C) mounted on right end of lathe bed. Tighten locking lever (K).

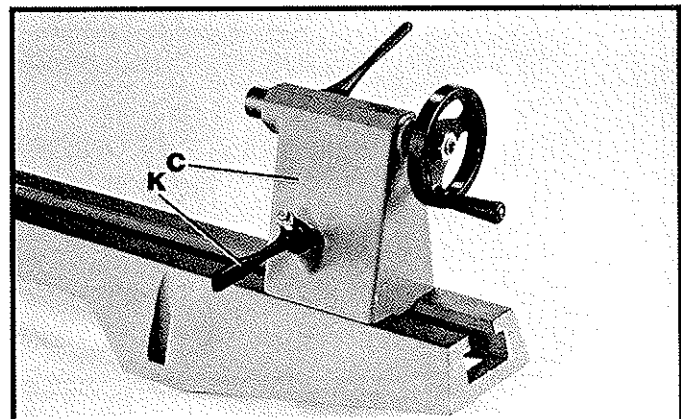

Fig. 11

# CONNECTING LATHE TO POWER SOURCE

## POWER CONNECTIONS

A separate electrical circuit should be used for your tools. This circuit should not be less than #12 wire and should be protected with a 20 Amp time lag fuse. If an extension cord is used, use only 3-wire extension cords which have 3-prong grounding type plugs and 3-pole receptacles which accept the tools plug. For distances up to 100 feet use #12 wire. For distances up to 150 feet use #10 wire. Have a certified electrician replace or repair damaged or worn cord immediately. Before connecting the motor to the power line, make sure the switch is in the "OFF" position and be sure that the electric current is of the same characteristics as stamped on motor nameplate. All line connections should make good contact. Running on low voltage will injure the motor.

## GROUNDING INSTRUCTIONS

**WARNING: THIS TOOL MUST BE GROUNDED WHILE IN USE TO PROTECT THE OPERATOR FROM ELECTRIC SHOCK.**

In the event of a malfunction or breakdown, grounding provides a path of least resistance for electric current to reduce the risk of electric shock. This tool is equipped with an electric cord having an equipment-grounding conductor and a grounding plug. The plug must be plugged into a matching outlet that is properly installed and grounded in accordance with all local codes and ordinances.

Do not modify the plug provided - if it will not fit the outlet, have the proper outlet installed by a qualified electrician.

Improper connection of the equipment-grounding conductor can result in risk of electric shock. The conductor with insulation having an outer surface that is green with or without yellow stripes is the equipment-grounding conductor. If repair or replacement of the electric cord or plug is necessary, do not connect the equipment grounding conductor to a live terminal.

Check with a qualified electrician or service personnel if the grounding instructions are not completely understood, or if in doubt as to whether the tool is properly grounded.

Use only 3-wire extension cords that have 3-prong grounding type plugs and 3-hole receptacles that accept the tool's plug, as shown in Fig. 12.

Repair or replace damaged or worn cord immediately.

This tool is intended for use on a circuit that has an outlet and a plug that looks like the one shown in Fig. 12. A temporary adapter, which looks like the adapter illustrated in Fig. 13, may be used to connect this plug to a 2-pole receptacle, as shown in Fig. 13, if a properly grounded outlet is not available. The temporary adapter should be used only until a properly grounded outlet can be installed by a qualified electrician. **THIS ADAPTER IS NOT APPLICABLE IN CANADA.** The green-colored rigid ear, lug, and the like, extending from the adapter must be connected to a permanent ground, such as a properly grounded outlet box, as shown in Fig. 13.

**CAUTION: IN ALL CASES, MAKE CERTAIN THE RECEPTACLE IN QUESTION IS PROPERLY GROUNDED. IF YOU ARE NOT SURE HAVE A CERTIFIED ELECTRICIAN CHECK THE RECEPTACLE.**

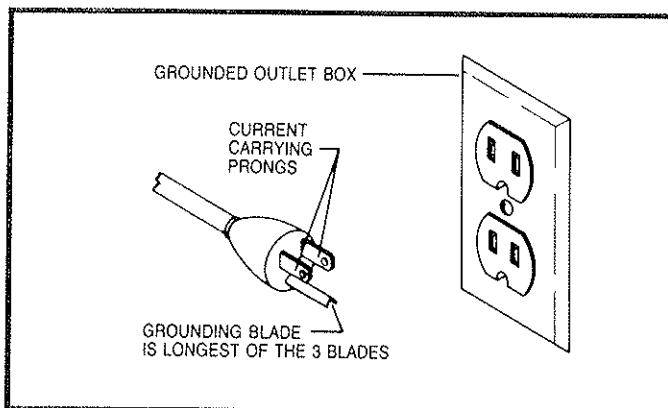

Fig. 12

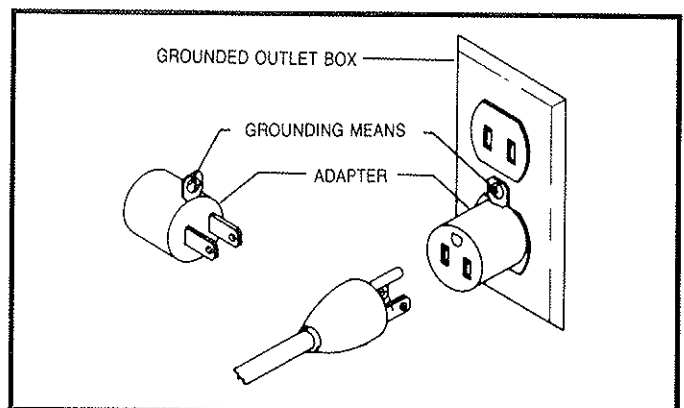

Fig. 13



# FASTENING LATHE TO SUPPORTING SURFACE

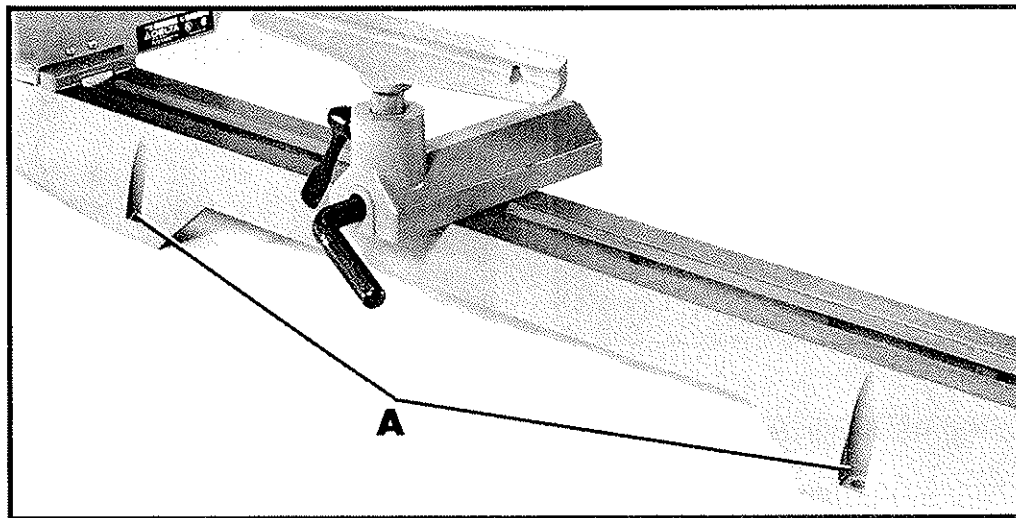

Fig. 14

This machine must be fastened to a supporting surface. Four holes, two of which are shown at (A) Fig. 14, are provided in the lathe bed for this purpose. **IMPORTANT:** If the lathe is to be mounted to the accessory 46-705 stand, the stand must be fastened to a supporting surface if it has any tendency to tip over, slide or "walk" during operation.

## OPERATING CONTROLS AND ADJUSTMENTS

### STARTING AND STOPPING LATHE

The switch (A) Fig. 15, is located on the end of the motor. To turn the lathe "ON" move the switch to the up position. To turn the lathe "OFF" move the switch to the down position.

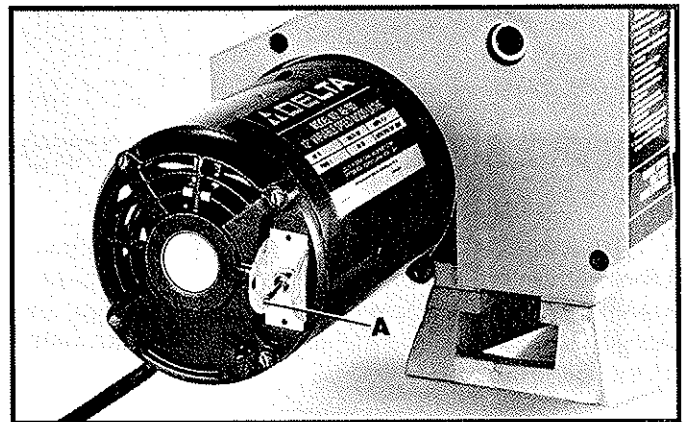

Fig. 15

### LOCKING SWITCH IN THE "OFF" POSITION

**IMPORTANT:** We suggest that when the lathe is not in use the switch be locked in the "OFF" position using a padlock (B) Fig. 16, through the holes in the switch bracket, as shown.

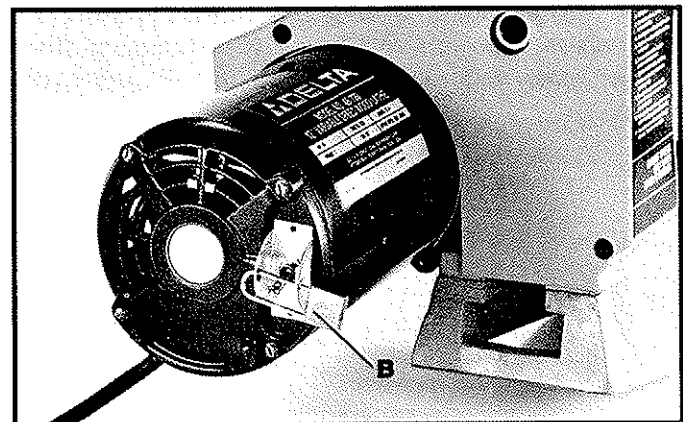

Fig. 16

# SPINDLE SPEEDS

Your 12" Wood Lathe is provided with variable rate spindle speeds from 500 to 2000 RPM. **IMPORTANT: CHANGE SPEEDS ONLY WHEN LATHE IS RUNNING.** To change speeds, rotate speed control lever (A) Fig. 17. Turning the lever (A) clockwise increases the speed and turning it counterclockwise decreases the speed. **NOTE:** Lever (A) is spring-loaded and can be repositioned by pulling out on the lever and repositioning it on the nut located underneath the lever.

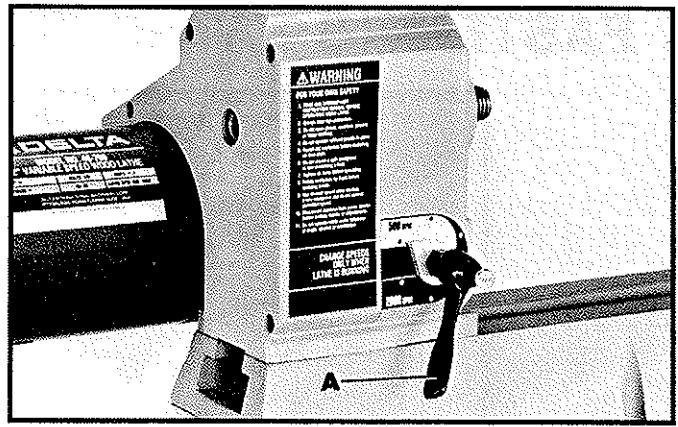

Fig. 17

Refer to Fig. 18, for the recommended spindle speeds when wood-turning on your machine.

## RECOMMENDED SPINDLE SPEEDS

DIAMETER OF WORK	ROUGHING OFF	GENERAL CUTTING	FINISHING
Under 2" Dia.	900 to 1300 RPM	1200 to 2000 RPM	1500 to 2000 RPM
2" to 4" Dia.	600 to 1000 RPM	1000 to 2000 RPM	1500 to 2000 RPM
4" to 6" Dia.	600 to 800 RPM	1000 to 1800 RPM	1500 to 2000 RPM
6" to 8" Dia.	500 to 600 RPM	800 to 1200 RPM	1200 to 1800 RPM
8" to 12" Dia.	500 RPM	600 to 800 RPM	900 to 1200 RPM

Fig. 18

## REPOSITIONING HEADSTOCK FOR OUTBOARD TURNING

1. To reposition headstock (A) Fig. 19, for outboard faceplate turning, loosen locking screw located directly underneath headstock with wrench (B) supplied, just enough to allow you to slide headstock (A) to the center of the lathe bed.

2. With headstock (A) Fig. 19, in position at the center of the lathe bed, loosen the headstock locking screw again, just enough to allow you to rotate headstock (A) 90 degrees to the right until spindle (C) is facing out. Then tighten screw underneath headstock (A) with wrench (B).

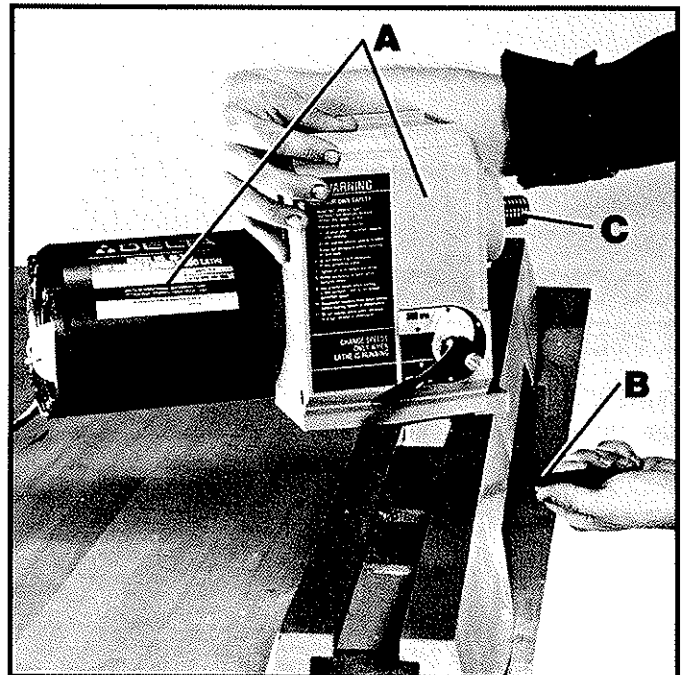

Fig. 19

## TOOL REST

The tool rest (A) and tool rest base (B) is shown in Fig. 20. To position the tool rest on the lathe bed, lift up clamp handle (C), move the tool rest base to the desired position and lock in place by pushing down on handle (C). To adjust the tool rest (A) for the correct height, loosen locking lever (D), move tool rest (A) up or down and tighten locking lever (D). **NOTE:** Locking lever (D) can be repositioned by removing nut (E) and lever (D). Reposition lever (D) on the nut located underneath the lever (D) and replace nut (E). Clamping action of clamp handle (C) Fig. 21, can be adjusted by removing the tool rest base from the lathe bed and tightening or loosening nut (F).

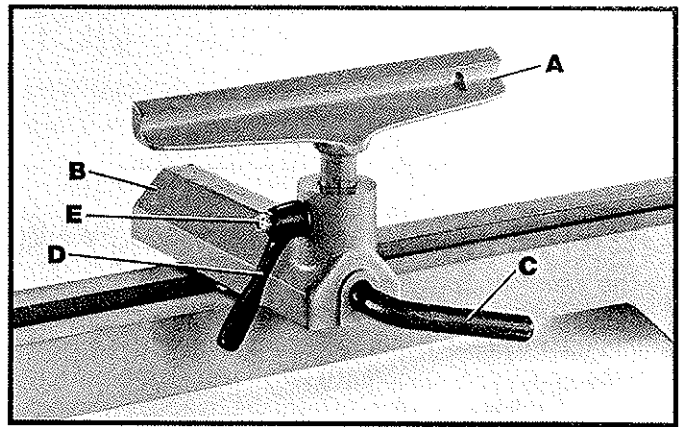

Fig. 20

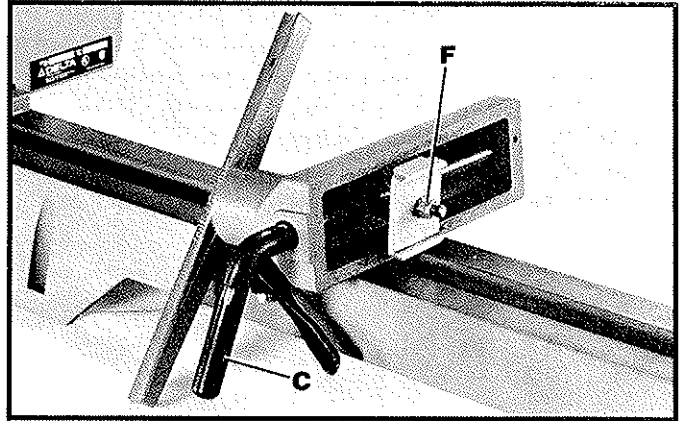

Fig. 21

## TAILSTOCK

The tailstock (A) Fig. 22, can be moved lengthwise along the lathe bed by loosening locking lever (B), sliding tailstock (A) to the desired position on the bed, and tightening lever (B).

The tailstock spindle (C) Fig. 22, moves in or out of the tailstock body by loosening locking lever (D) and turning handwheel (E). Total movement of the tailstock spindle (C) is two inches. The tailstock spindle is hollow the complete length of the tailstock enabling you to bore holes through turnings as shown later in this manual. **NOTE:** Locking lever (B) is spring-loaded and can be repositioned by pulling out on the handle and repositioning it on the nut located underneath the lever. Locking lever (D) Fig. 23, can be repositioned by removing nut (F) and lever (D). Reposition lever (D) on the nut located underneath lever (D) and replace nut (F).

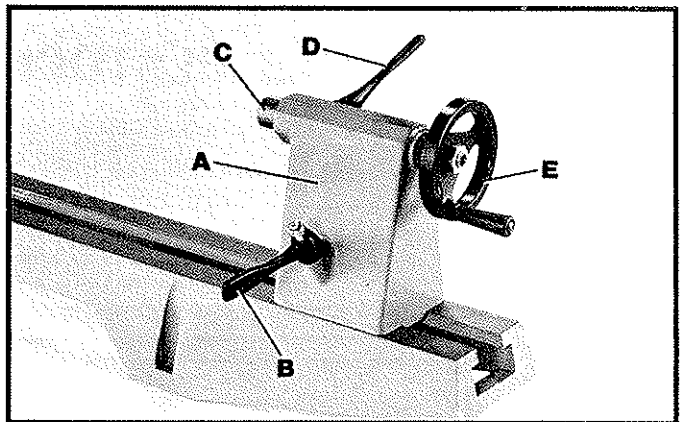

Fig. 22

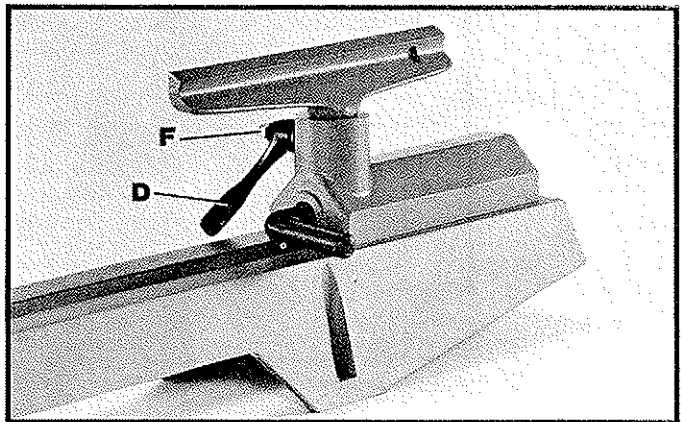

Fig. 23

## HEADSTOCK SPUR CENTER

The spur center (A) Fig. 24, supplied with your lathe, is equipped with a No. 2 Morse Taper shank and is inserted into the headstock spindle (B) as shown. To remove the tapered shank spur center (A) from the headstock spindle, use a dowel rod or a piece of soft metal rod through the hole (C) Fig. 25, in the opposite end of the spindle. Available as an accessory for your lathe is the Cat. No. 46-905 Knockout Bar which is ideal for this purpose. It is equipped with a brass plug on one end and a comfortable knob on the other. **IMPORTANT: NEVER DRIVE THE WORKPIECE INTO THE SPUR CENTER WHEN IT IS MOUNTED IN THE HEADSTOCK.** Instructions on setting the spur center into the workpiece are found in the **OPERATION** section of this manual.

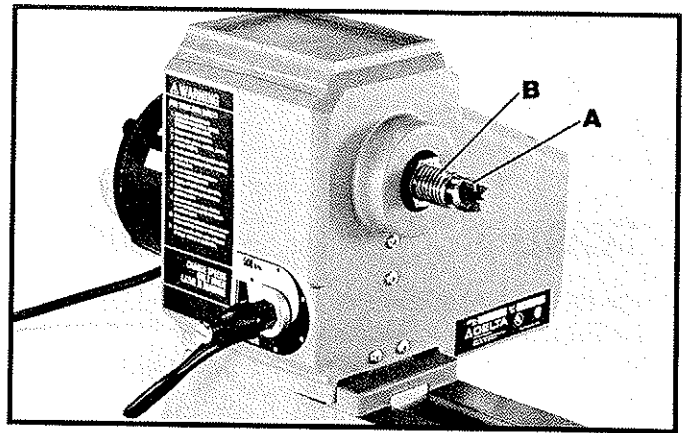

Fig. 24

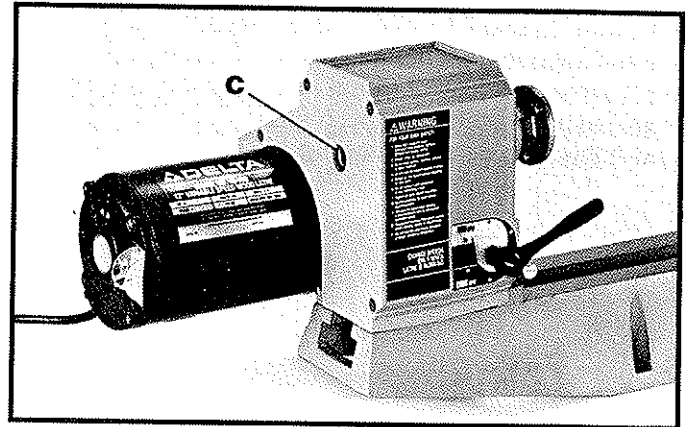

Fig. 25

## TAILSTOCK CUP CENTER

The tailstock cup center (A) Fig. 26, supplied with your lathe, is equipped with a No. 2 Morse Taper shank and is inserted into the tailstock spindle (B), as shown. To remove the tapered shank cup center (A) from the tailstock spindle, simply rotate handwheel (C) to move spindle (B) back into the tailstock body. This will push the cup center (A) out of the spindle (B).

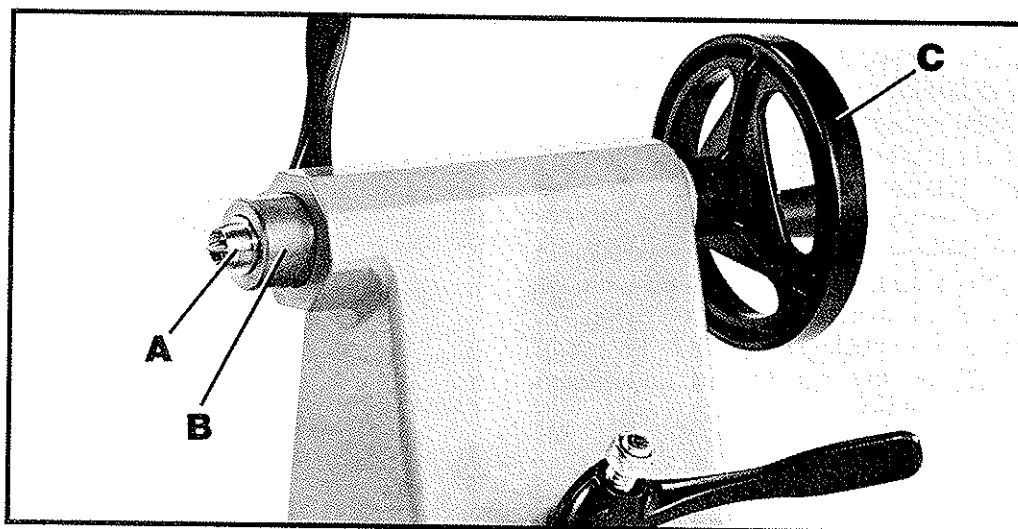

Fig. 26

# OPERATION

The following directions will give the inexperienced operator a start on the common lathe operations. Use scrap material for practice to get the feel of the machine before attempting regular work.

## LATHE TOOLS

The standard set of tools used in wood turning comprises five different shapes as shown in Fig. 27. Most important of these is the gouge, a roundnose, hollow chisel which is used for roughing cuts, cove cutting and other operations. Next in importance is the skew chisel, a double-ground, flat chisel, with the end ground to an angle instead of being square across. This tool is used for smoothing cylinders, for cutting shoulders, beads, vee-grooves, etc. The spear or diamond-point chisel and the round-nose chisel are scraping tools which are used where their shape fits the contour of the work. The parting tool is a double-ground chisel, and is used for cutting-off and for making straight incisions or sizing cuts to any required diameter.

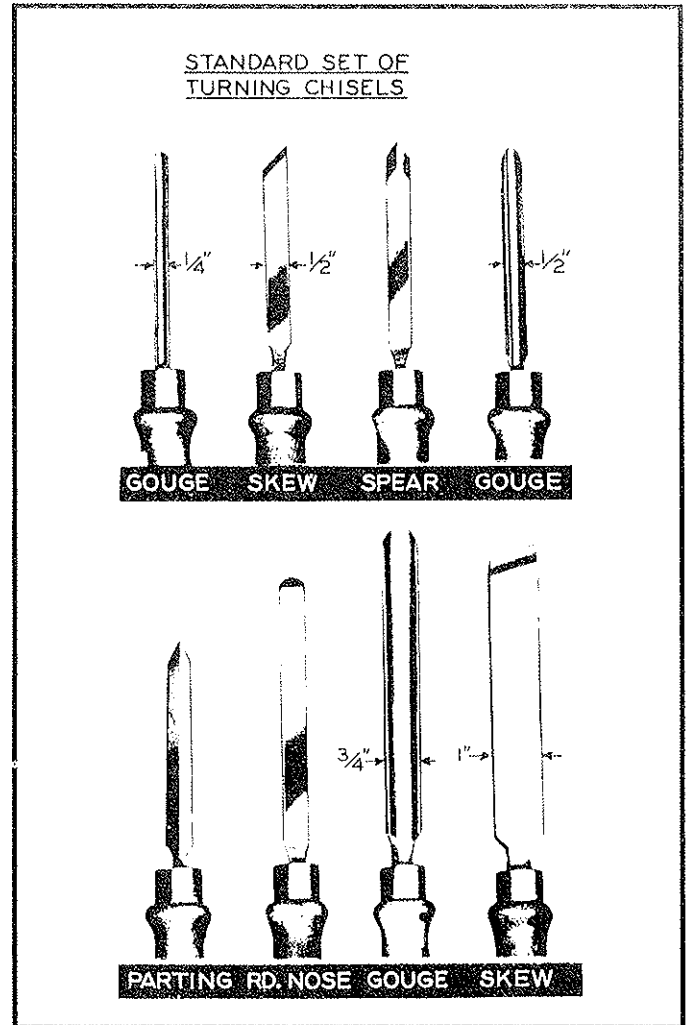

Fig. 27

## HOW TO TURN SPINDLES

Any turning where the workpiece is placed between the headstock and tailstock centers, as shown in Fig. 28, is called spindle turning. This is the principle type of wood turning, as typified by chair and table legs, lamp stems, etc. The turning of spindles can be done with either a scraping or cutting technique, the cutting technique by virtue of faster wood removal and a cleaner surface being almost a must for good work. Fig. 29, illustrates a spindle turning operation being performed.

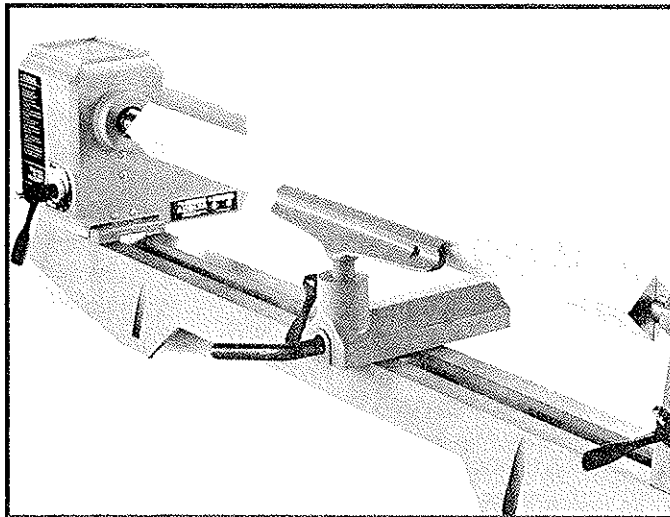

Fig. 28

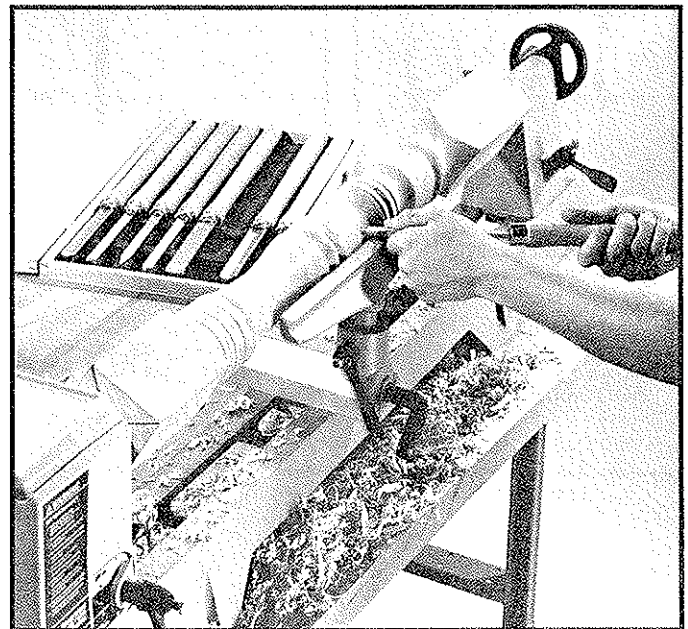

Fig. 29

# CENTERING THE WORK

Wood stock for any spindle turning should be approximately square, and the ends should be square with the sides. Two common methods of determining the center are shown in Fig. 30 and 31. In Fig. 30 a distance a little more or a little less than one-half the width of the stock is set off from each of the four sides. The small square thus set off in the center can then be used in marking the true center. The diagonal method, Fig. 31, consists of drawing lines from corner to corner, the intersection marking the center of the work.

After marking each end, the true center should be definitely marked with a punch awl or dividers, as shown in Fig. 32. If the stock is hardwood, the centers should be drilled to a depth of about 1/8", as shown in Fig. 33. The spur or live center is then placed against one end of the work and seated by striking with a mallet, as shown in Fig. 34. In hardwood, it is advisable to make a starting seat for the spur center, this being done by sawing on the diagonal lines, as shown in Fig. 35, and drilling a small hole at the intersection. After driving the center, it is best to hold center and work together and fit immediately to headstock spindle. If you are not using a ball bearing center, the end of work at tailstock center should be oiled, placing the lubricant on the wood either before or after it is put in the lathe, see Fig. 36. Many turners use beeswax, tallow, or a wax-and-oil mixture as a lubricant. The ideal method is to use a ball bearing center, which eliminates lubricating entirely. If the work is to be removed from the lathe before completion, an index mark should be made as a guide for recentering, as shown in Fig. 37. A permanent indexer can be made by grinding off one corner of one of the spurs.

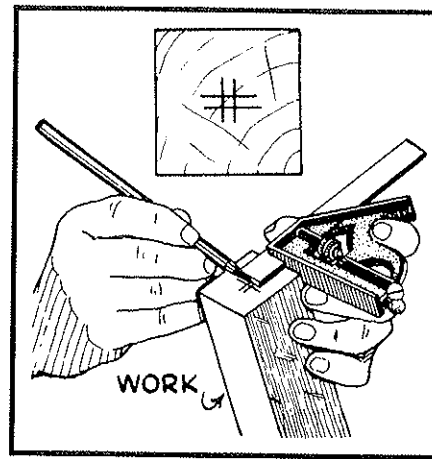

Fig. 30

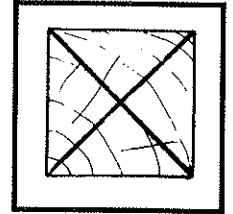

Fig. 31

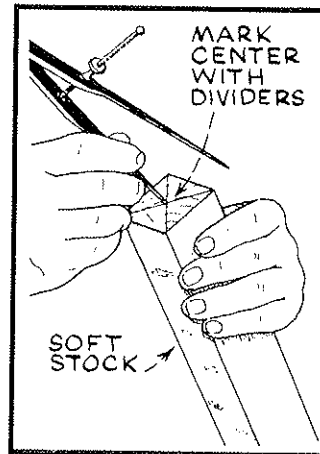

Fig. 32

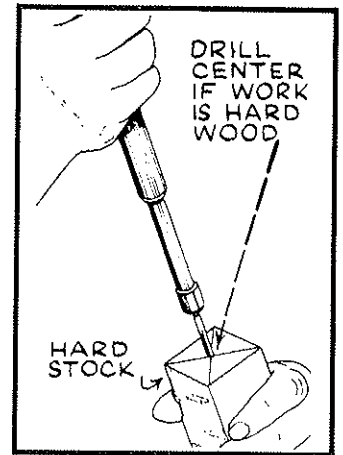

Fig. 33

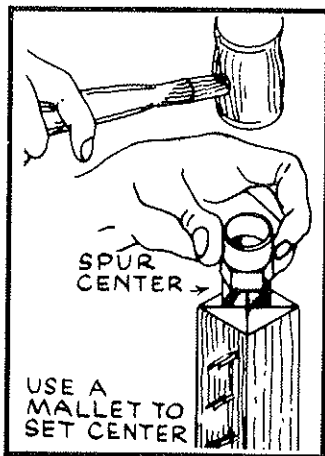

Fig. 34

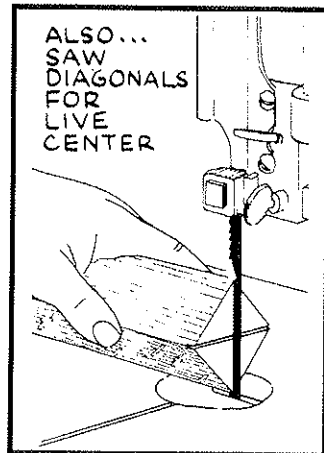

Fig. 35

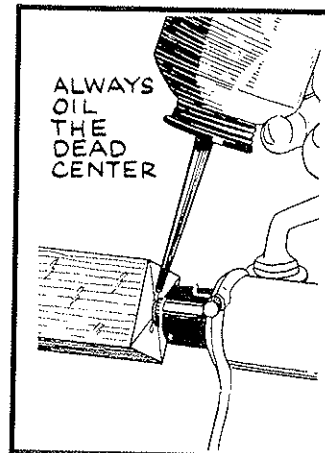

Fig. 36

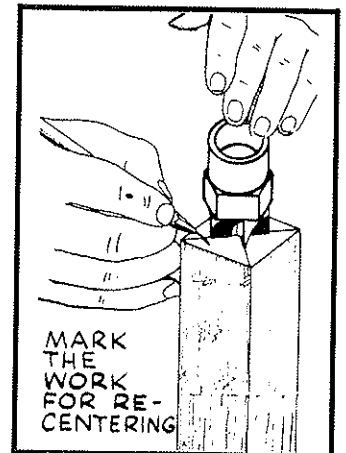

Fig. 37

# MOUNTING THE WORK

Mounting the work is done by moving the tailstock up to a position about 1 or 1 1/2" from the end of the stock, and locking it in this position. Advance the tailstock center by turning the feed handle until the center makes contact with the work. Continue to advance the center while slowly rotating the work by hand. After it becomes difficult to turn the work, slack off on the feed about one-quarter turn and lock the tailstock spindle.

## TOOL REST POSITION

The tool rest is now mounted, in place, about  $1/8''$  away from the work and  $1/8''$  above the work centerline, as shown in Fig. 38. This position may be varied to suit the work and the operator. A guide mark to show the most suitable working position can be placed on the tool rest shank as an aid to quick and accurate re-setting. Once some experience has been obtained, the setting of the tool rest will become almost second-nature.

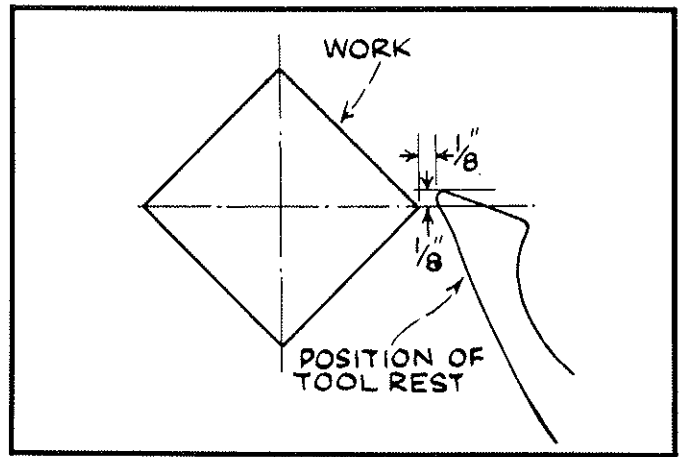

Fig. 38

## ROUGHING A CYLINDER

The large gouge is used in the first turning operation of roughing-off the sharp corners of the work. Run the lathe at low speed and hold the gouge in the manner shown in Fig. 39. The cut starts about 2 inches from the tailstock end, and continues from this point towards and off the tailstock end. A second bite is then taken about 2 or 3" to the left of the first cut, advancing again towards the tailstock to merge with the cut previously made. The procedure continues until a point about 2" from the live center is reached where the gouge is rolled in the opposite direction to carry the final cut off the live center end of the work. The roughing cut should not be carried out with one continuous movement as this tends to tear long slivers from the corners of the work; neither should the cut be started directly at the end of the stock for the same reason. The cut can be safely carried from the center of the stock towards and off either end once the first roughing cut has been made.

The position of the gouge in relation to the work involves two or three important angles. First of all, the tool may be advanced along the work either from right to left or from left to right. From left to right or from headstock towards tailstock is preferable, since this throws the chips clear of the operator. The gouge is rolled over slightly in the same direction it is advancing; as shown in Fig. 40. The tool is held well up on the work, with the bevel or grind tangent to the revolving surface, as shown in Fig. 41. In this position it will make a clean, shearing cut. When pushed straight into the work, like Fig. 42, the gouge has a scraping action, which is normally poor practice in spindle turning. The roughing cut is continued until the work approaches  $1/8''$  of the required diameter, stepping up to second or third speed once a barely cylindrical form has been obtained.

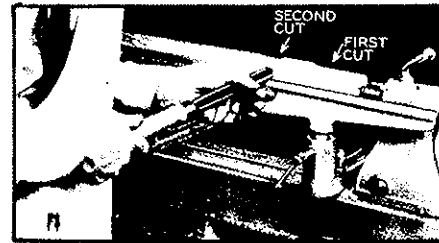

Fig. 39

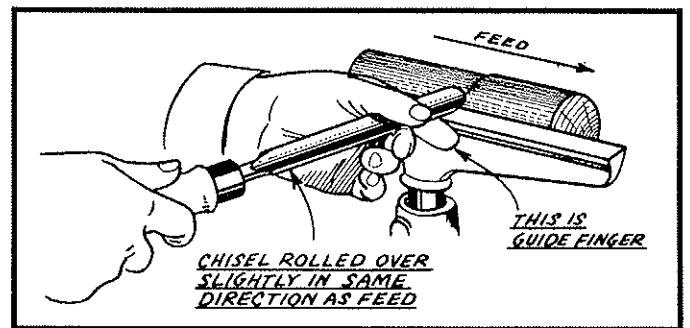

Fig. 40

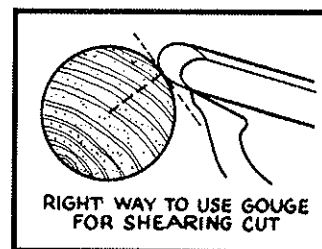

Fig. 41

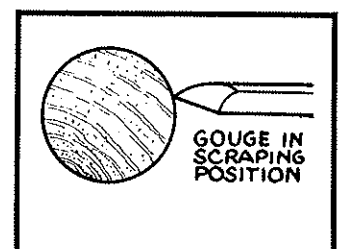

Fig. 42



## POSITION OF HANDS

In all tool handling, the handle hand takes a natural position, being nearer or further from the end of chisel depending on the amount of leverage required. The position of the tool rest hand is more a matter of individual liking rather than any set or "proper" position. However, a palm-up grip, as illustrated with the gouge, is generally considered the best practice. In this position, the first finger acts as a guide, as shown in Fig. 43, sliding along the tool rest as the cut is made. The alternate position is a palm-down grip, which is shown in Fig. 44. In this position, the heel of the hand or the little finger serves as a guide. The palm-down position is solid and positive-excellent for roughing or heavy cutting. Most beginners start with the palm-down grip, switching later to the palm-up position for better manipulation of the chisel.



Fig. 43



Fig. 44

## SMOOTHING A CYLINDER

This operation is done with the large skew chisel. It demands a little practice, but should be mastered thoroughly because it is one of the most important cuts in turning. Fig. 43 and 44 show how the chisel is held, using either grip as desired. The cutting point is near the center of chisel and high on the work, as shown in Fig. 45. The chisel must be supported by the tool rest at all times - in striving for a certain position in relation to the work, the beginner often overlooks this all-important point. Beginners often use the method shown in Fig. 45 to locate the proper tool position. To do this, you place the skew well over the work and riding-flat against it.

Pulling back slowly on the tool will eventually put it into position where it will bite into the wood. Raising the handle increases the depth of cut; lowering the handle makes the cut less. As with the gouge, the skew can be advanced in either direction. The part of the skew which does the actual cutting is the center portion and toward the heel. It is worthwhile to stop a test cut in progress and note just how the skew cuts. You will note that the back portion of the grind or bevel supports the tool, and the handle hand controls the depth of cut by rocking the chisel on this pivot point. For this reason it is important that the skew bevel be kept perfectly flat, not a double bevel nor rounded.

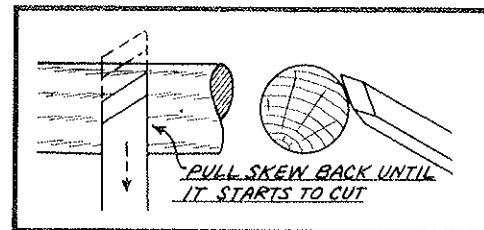

Fig. 45

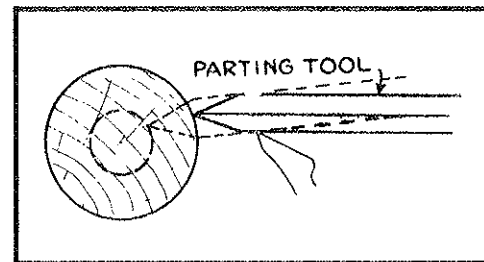

Fig. 46

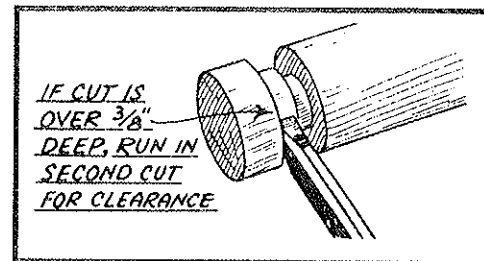

Fig. 47

## USING THE PARTING TOOL

The parting tool is perhaps the easiest turning chisel to handle. It is a scraping tool, and is simply pushed into the work, as shown in Figs. 46, 47 and 48. A somewhat better cutting action is obtained if the handle is held low, raising gradually as the work diameter decreases, as shown in Fig. 46. The tool is frequently used with one hand, the other hand holding calipers in the groove being cut. When parting tool cuts are deep, a clearance cut should be made alongside the first cut, as shown in Fig. 47, to prevent burning the tool point.



Fig. 48



# SQUARING AN END

This operation can be done with parting tool. However, the parting tool is a rough cutter, so that ultimately the skew must be used in cleaning the cut. The whole operation can be done with the skew, and this technique is illustrated by the drawings in Figs. 49, 50 and 51. The first movement is a nicking cut with the toe of the skew, as shown in Fig. 49. This cut cannot be made very deep without danger of burning the chisel, so a clearance cut is made by inclining the skew away from the first cut and again pushing the tool into the work. This procedure of side cut and clearance cut is continued as often as needed. The important point to note is that while the skew can be pushed into the wood in any direction, the cutting edge itself must be inclined a little away from this plane, see Fig. 51. Note that if the full cutting edge of skew bears against the cut surface, the tool will have a tendency to run. Now, observe the proper way to make the cut, as shown at left end of Fig. 51. The chisel is pushed straight into the work, but the cutting edge is inclined away from the cut surface - only the extreme toe cuts. This is the most important principle in skew handling, and you will run into it repeatedly in making shoulders, beads and vee cuts.

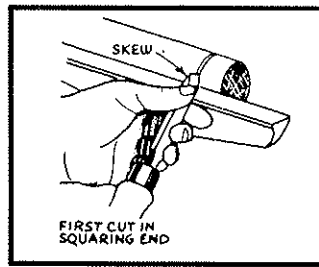

Fig. 49

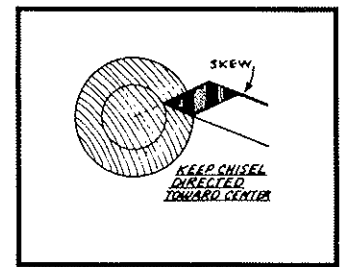

Fig. 50

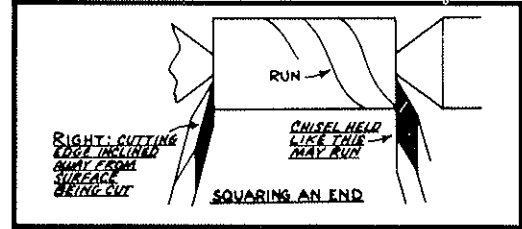

Fig. 51

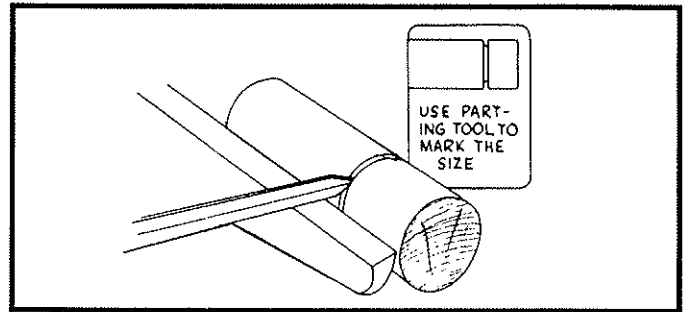

Fig. 52

# CUTTING A SHOULDER

The parting tool is first used to reduce the wood to within 1/16" of the required shoulder and diameter, as shown in Fig. 52. The waste stock is then cleaned out with the gouge, Fig. 53. Actual cutting of the shoulder is done with the skew, as shown in Fig. 54, and is a duplication of squaring end. The horizontal cut is also made with the skew, but in a little different manner from that used in doing plain cylinder work. If the shoulder is long, the ordinary skew position can be used for the outer portion of the cut, but at the angle between the horizontal and vertical cuts, the heel of the chisel moves into a position tangent between the skew and the cylinder, as shown in Fig. 55. In this position, the handle of the chisel is raised slightly to allow it to cut as the tool moves along the rest. A very light cut should be taken in order to produce smooth work. The heel of the skew can be used for making the entire cut, if desired, but the cut, whether in this position or any other position, should not be picked up directly at the end of the stock. It is quite evident that any horizontal cut started directly from the end of the work will have a tendency to bite into the wood, often ruining the entire piece. Always run off the end and not into it. Where a very short shoulder makes this impossible, it is best to use the skew flat in a scraping position. If the cutting technique is used, engage only with the heel of skew in a very light cut.

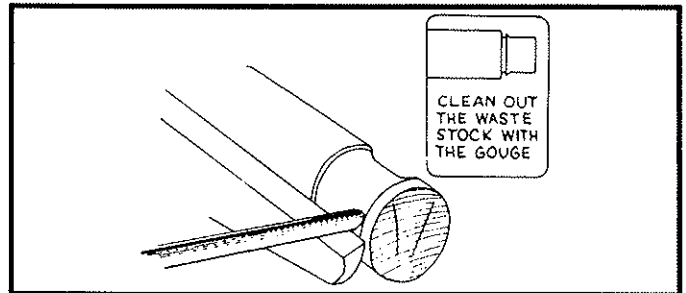

Fig. 53

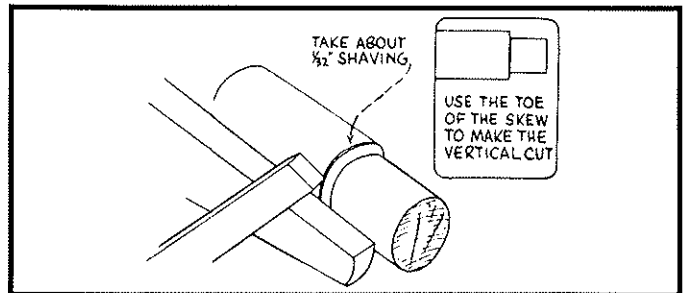

Fig. 54

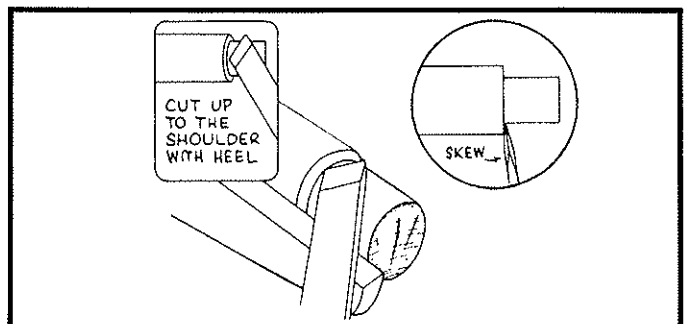

Fig. 55

## CUTTING SMALL BEADS

Beads can be scraped or cut. The easy method of scraping is done with the spear chisel, and works to best advantage on beads separated by parting tool cuts, as shown in Fig. 56. Scraping is slower and less productive of clean work than cutting, but it has the advantage of perfect safety - you won't spoil the work with long gash runs.

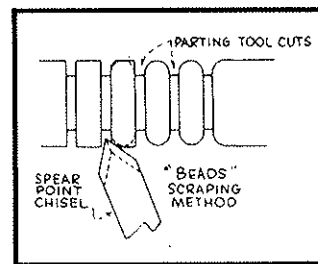

Fig. 56

Cutting beads quickly and accurately with the small skew is one of the most difficult lathe operations. Various working methods can be used, the usual system being as shown in Figs. 57, 58 and 59. The first cut is a vertical incision at the point where the two curved surfaces will eventually come together. This cut can be made with either heel or toe of skew, Fig. 60 showing the toe being used. Now, place the skew at right angles to the work and well up on the cylinder, as shown in Fig. 57. The chisel is flat on its side at the start, and is evenly rotated through the successive stages of the cut, as shown in Figs. 57, 58 and 59. At the same time, the chisel is pulled slightly backwards to maintain the cutting point. The entire cut is made with the heel of chisel. The opposite side of the bead is cut in the same manner, one cut serving to produce the full shape in each instance. Beads cut in this manner are beautifully smooth and polished, and the technique is well worth mastering.



Fig. 57



Fig. 58



Fig. 59

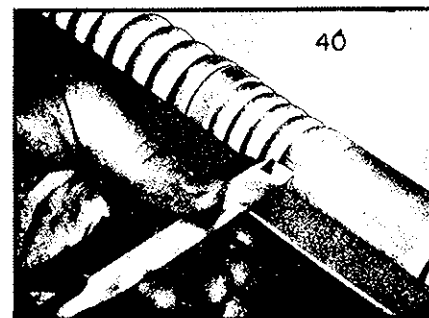

Fig. 60

## VEE GROOVES

Cutting the vee groove demands much the same technique as the bead, except the skew is hinged straight into the work without rotation, as shown in Fig. 61. Only one-half of the vee is made at a time, and one, two or more cuts may be needed on each side to obtain the desired shape. As in all cutting with the skew, the bevel next to the cut must be used as a fulcrum, without at the same time allowing the full edge of the chisel to catch and cause a run. Vee grooves can also be made with the toe of the skew, in the manner already described for squaring an end.

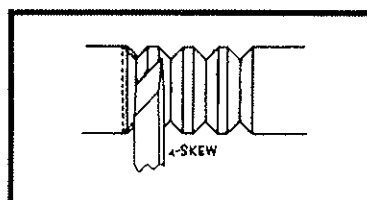

Fig. 61

## LONG CUTS

Long cuts are usually either convex or straight-tapered surfaces. With a convex surface, the method used in making the finishing cut is shown in Fig. 62 and 63. The gouge is turned on the tool rest so that it will be inclined considerably in the direction in which it is about to move. The grind is tangent to the work, and the center point of the cutting edge is the contact point with the wood. As the cut progresses towards and around the end of the curve, the handle is gradually raised and swung to the right, as shown in Fig. 63, in order to maintain the tangency between the grind and the surface being cut, as shown in Fig. 64.

Figs. 65 and 66 show the cutting of a long taper. The skew is used, and the operation differs from smoothing a cylinder only as regards the start of the cut. The starting cut should be made with the heel, as shown in Fig. 66, to prevent the tool from digging into the work. As the tool runs down the work, the chisel can be pulled back to allow the center point of the cutting edge to cut. However, the full taper can be made with the heel. There will be a tendency to cut too deeply at the center of the taper which should be guarded against. The direction of cutting is always downhill.

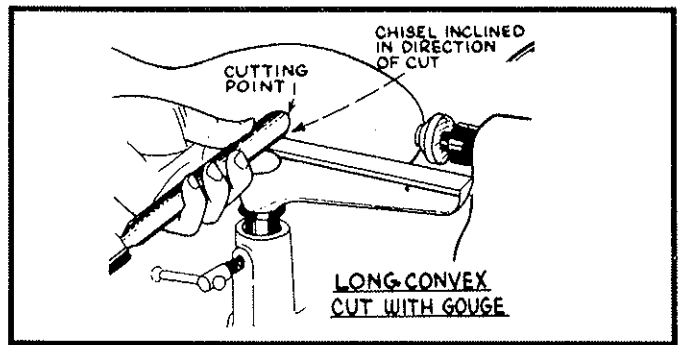

Fig. 62

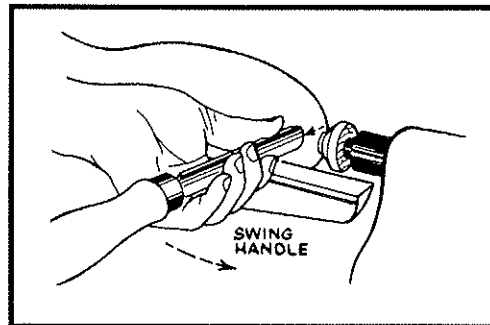

Fig. 63



Fig. 64



Fig. 65

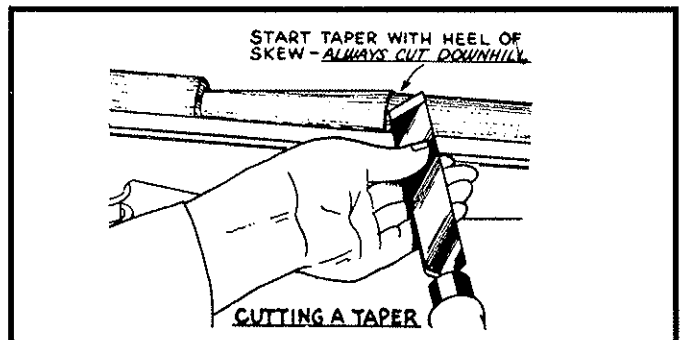

Fig. 66

## COVE CUTS

Second to forming a perfect bead, the cove or concave cut is the most difficult to master. This cut is made with the gouge, the size of the tool depending upon the size of the cut. The size of the intended cove is first laid out, and the gouge is pushed directly into the work to remove the surplus stock, as pictured in Fig. 67. The cove cut can now be made.

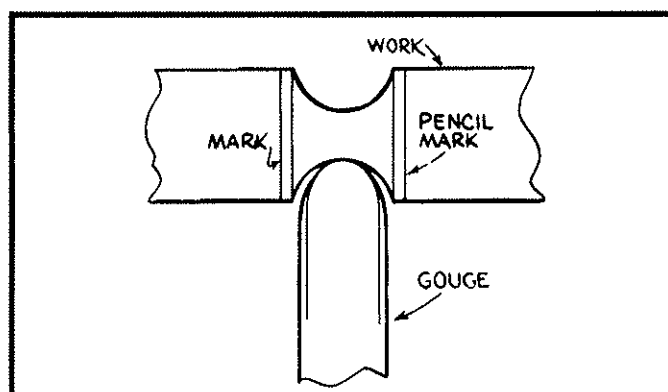

Fig. 67

The gouge is placed on edge on the tool rest in such a position that the grind of the chisel forms an approximate right angle with the work, as shown in Figs. 68 and 69. The chisel contacts the work at the center of the cutting edge, the tool being held so that the centerline of the gouge is pointing directly towards the center of the revolving stock, as shown in Fig. 70. This starting position is important; otherwise the gouge will have a tendency to run along the surface of the work.

From the starting position, the gouge is pushed into the revolving stock, and the tool is rolled on the rest. A triple action takes place here: First, the chisel is rolled to follow the shape of the cut; second, the handle is dropped slightly so that the portion already cut will force the lip of the chisel sidewise; third, the chisel is pushed forward so that at the end of the cut, Fig. 71, it will be well up on the work and tangent with the cut surface. Only one-half of the cut is made at one time, then the chisel is reversed to cut the other half. The occasional turner is advised to make cove cuts with a scraping technique, using either the small gouge or round nose chisel.

## SQUARE SECTIONS

When the turning has a square section, the stock should be jointed before turning. Good centering is essential since any error will show at the shoulder where the round meets the square. Turning of the shoulder from square to round can be done in various ways, one method being pictured in Figs. 72, 73, 74 and 75. If the parting tool is sharp, the nicking cut with skew, Fig. 72, can be omitted. The final trimming operation Fig. 75, can be done with either the skew or spear chisels. This is a scraping operation. While the shoulder can be cut with the same technique used for cutting a bead, the simpler scraping method pictured does clean work and is easier to do.

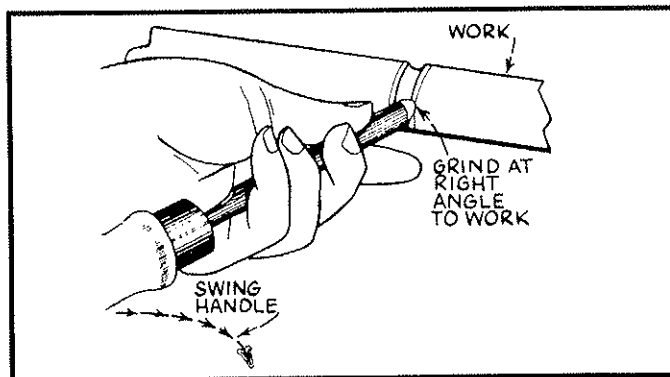

Fig. 68

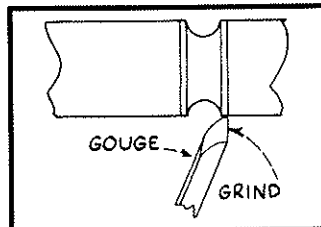

Fig. 69

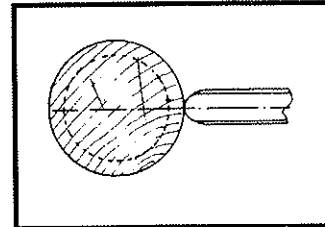

Fig. 70

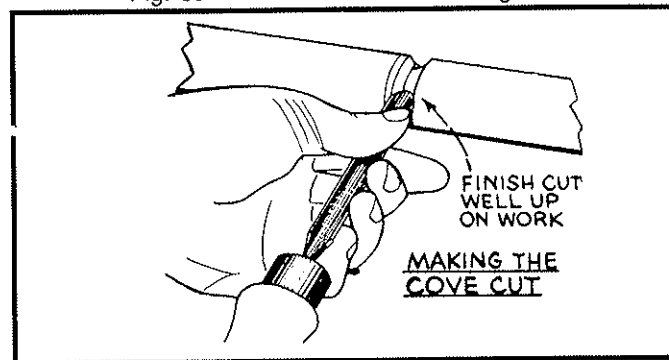

Fig. 71

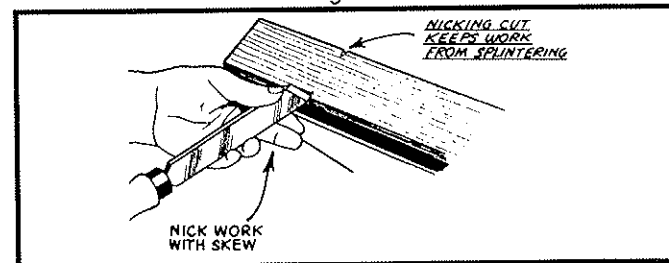

Fig. 72

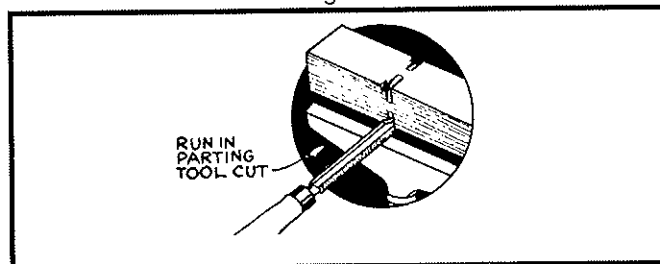

Fig. 73

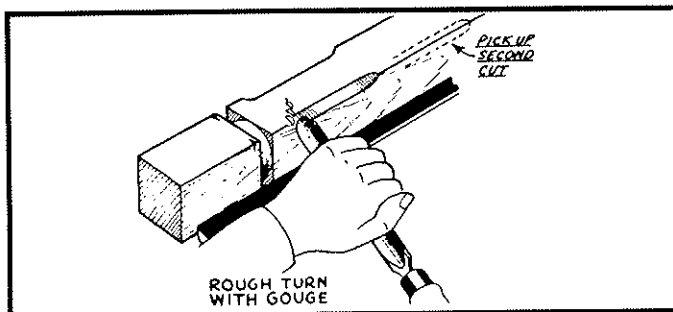

Fig. 74

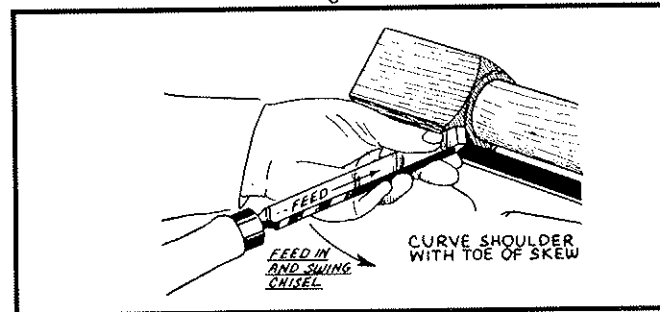

Fig. 75

# FACEPLATE TURNING

Turnings which cannot be worked between centers must be mounted on a faceplate or other work-holding device. The greater part of this type of turning is done with the faceplate mounting, although there are a number of jobs which require special chucks. All cutting in faceplate work is done by scraping; any attempt to use a cutting technique on the edge grain of large work will result in a hogging, gouging cut which may tear the chisel out of your hands. All work should be roughly band sawed a little oversize to eliminate heavy roughing cuts in turning.

## MOUNTING WORK TO FACEPLATE

Fig. 76 shows direct mounting to the 3" faceplate. Because it is easy to set up, this mounting should be used whenever the work permits. Larger pieces can be held in the same way by using the 6" faceplate. When normal screw-fastenings interfere, the work can often be mounted on a backing block, as shown in Fig. 77. When screws are not permissible at all, the work is glued to the backing block, fitting a sheet of paper at the joint to allow later separation without damaging the wood. Some work can be screwed or nailed from the face side into backing block. Work less than 3" diameter can be mounted on the single screw center, as shown in Fig. 78.

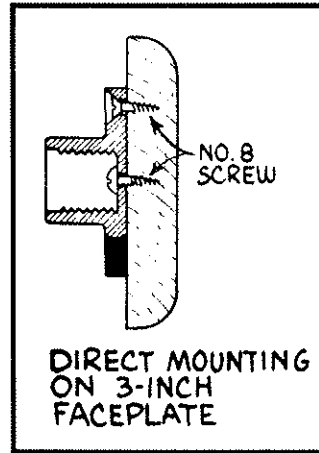

Fig. 76

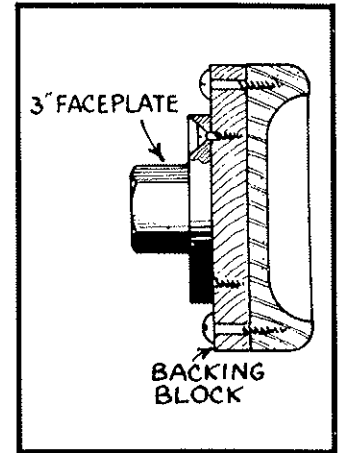

Fig. 77

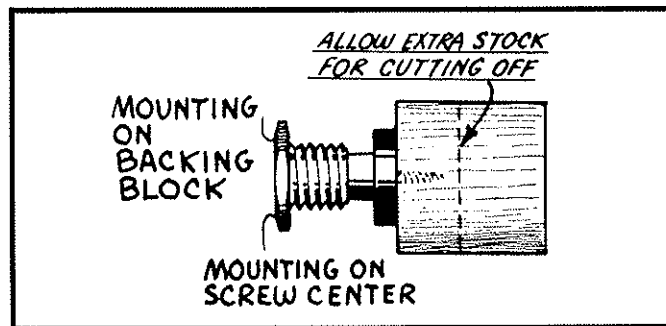

Fig. 78

## INBOARD FACEPLATE TURNING

Fig. 79, illustrates a typical inboard faceplate turning set-up. Inboard faceplate turning is used mostly when the workpiece (A) will rotate freely over the lathe bed, as shown. The workpiece (A) is mounted to a faceplate and the faceplate is threaded onto the spindle. Note that the standard equipment tool rest (B) can be adjusted to turn the outside diameter of the workpiece.

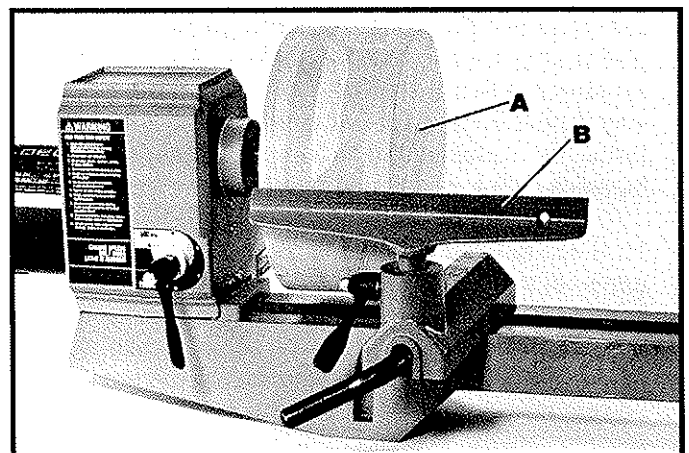

Fig. 79

Fig. 80, illustrates the standard equipment tool rest (C) adjusted to perform the turning operation on the outside surface (D) of the workpiece.

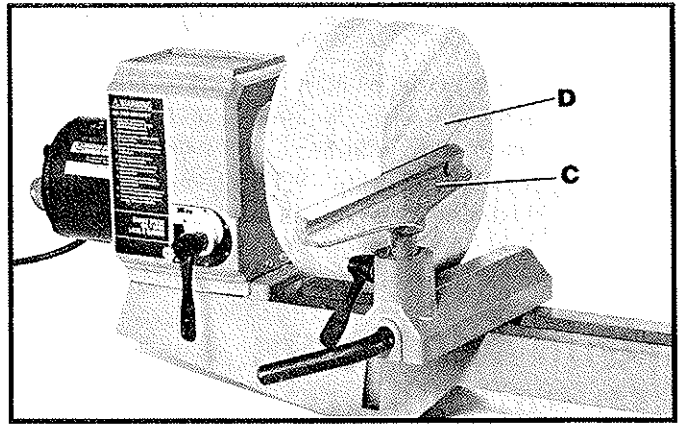

Fig. 80

Fig. 81, illustrates a typical inboard faceplate turning operation on the 12" Variable Speed Wood Lathe.

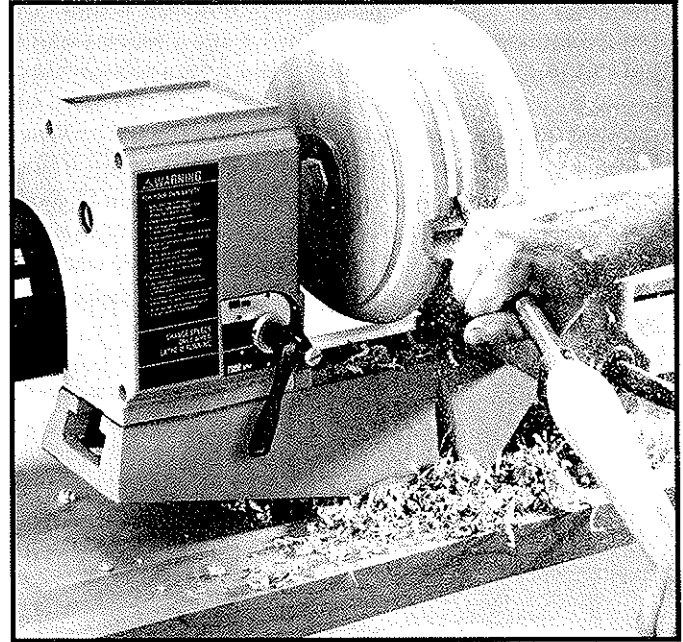

Fig. 81

## OUTBOARD FACEPLATE TURNING

Faceplate turning is usually performed inboard as previously explained; however, if the workpiece is too large to swing over the lathe bed it will be necessary to perform the operation in the outboard position. Some operators prefer outboard faceplate turning with smaller pieces also. It is more comfortable to stand in front of the workpiece rather than bending around the headstock as would be the case with inboard faceplate turning. The following explains setting up the lathe for outboard faceplate turning.

1. Loosen the headstock locking screw located directly underneath the headstock (A) Fig. 82, with wrench (B) just enough to move the headstock (A) to the center of the lathe bed. The headstock locking screw must be loosened again, just enough to permit you to turn the headstock (A) 90 degrees clockwise so that the spindle will be facing straight out. Then tighten the headstock locking screw.

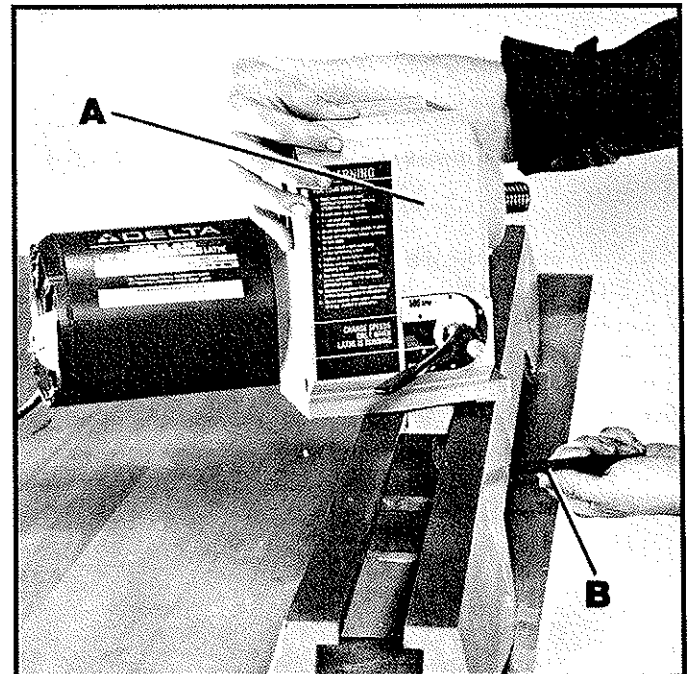

Fig. 82

2. The workpiece (C) Fig. 83, is then mounted to a faceplate and the faceplate is threaded onto the spindle, as shown.

3. Note that the standard equipment tool rest (D) Fig. 83, can be used to turn the outside diameter of the workpiece.

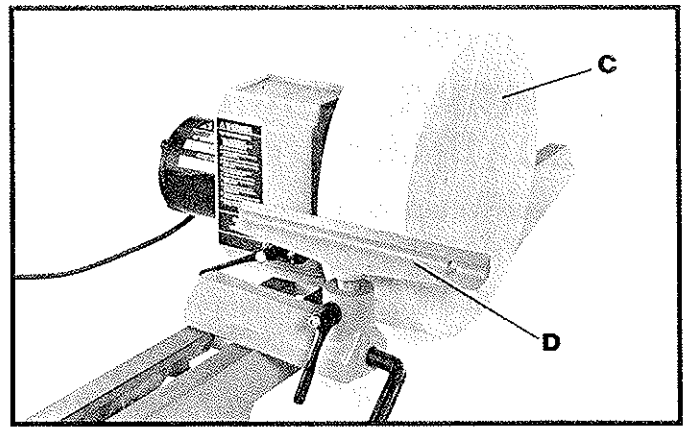

Fig. 83

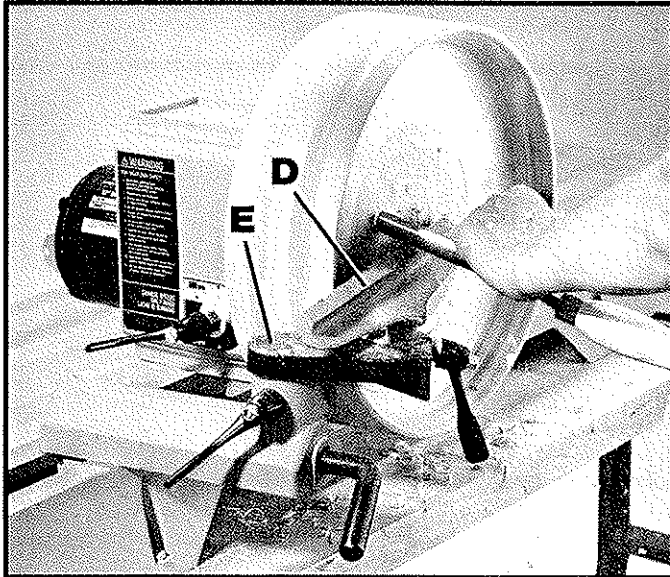

Fig. 84

4. Fig. 84, illustrates the standard equipment tool rest (D) being used along with the accessory 46-706 off-set base extension (E) to perform the inside turning operation.

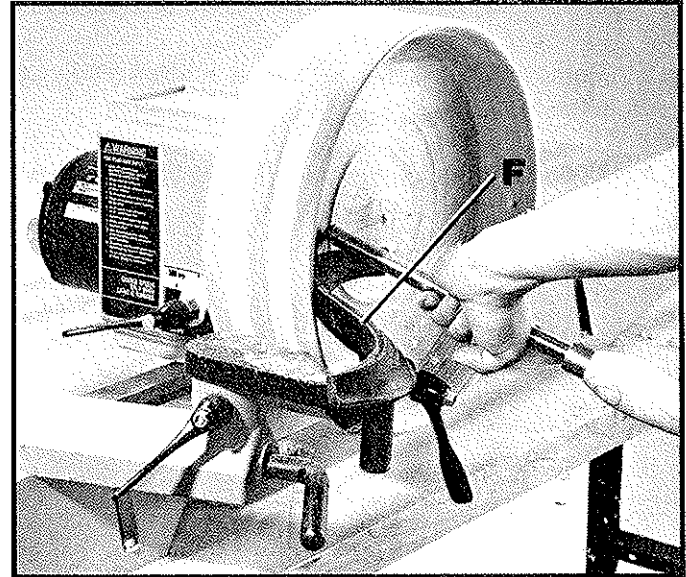

Fig. 85

5. As the inside turning operation becomes deeper it may be necessary to use the accessory 46-404 French Curl Tool Rest, shown at (F), to position the tool rest as close as possible to the workpiece as shown in Fig. 85.

## HOLLOW TAILSTOCK

This wood lathe is supplied with a 5/16" diameter hollow tailstock spindle that permits holes to be bored through the spindle using the accessory 46-708 hollow cup center and a compatible lamp auger (A), as shown in Fig. 86.

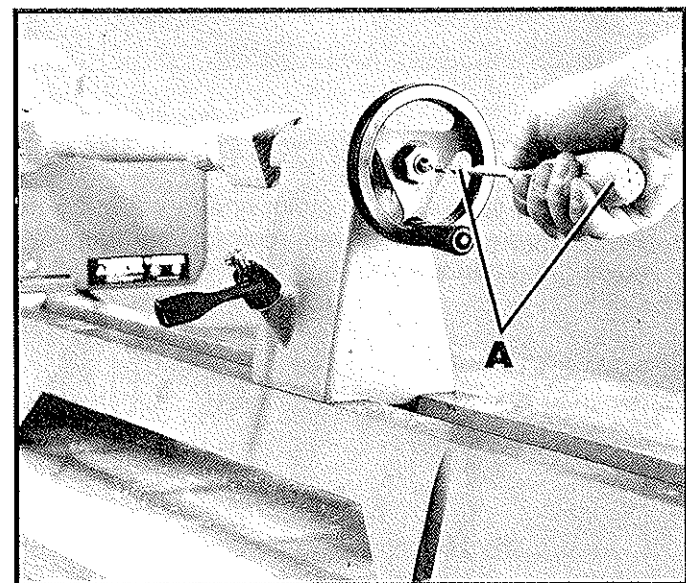

Fig. 86

# MAINTENANCE

## REPLACING VARIABLE SPEED DRIVE BELT

If it ever becomes necessary to replace the variable speed drive belt, proceed as follows:

1. Operate lathe at high speed, turn off switch and disconnect lathe from power source.
2. Remove the four screws (A) Fig. 87, located on the right side of the headstock.
3. Remove the five screws located in holes (B) Fig. 88, on left side of headstock.
4. Remove both left and right half headstock covers.

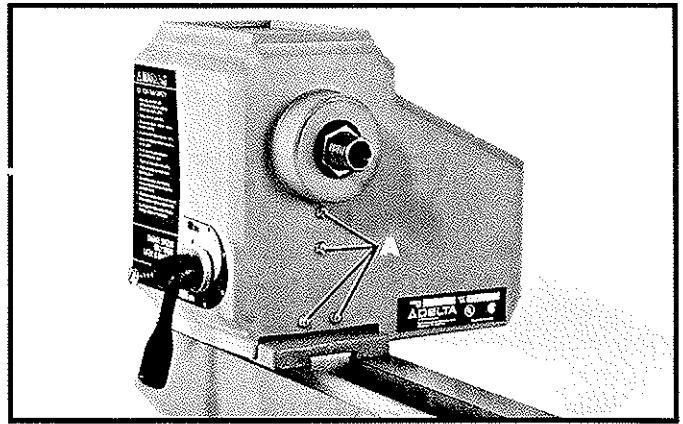

Fig. 87

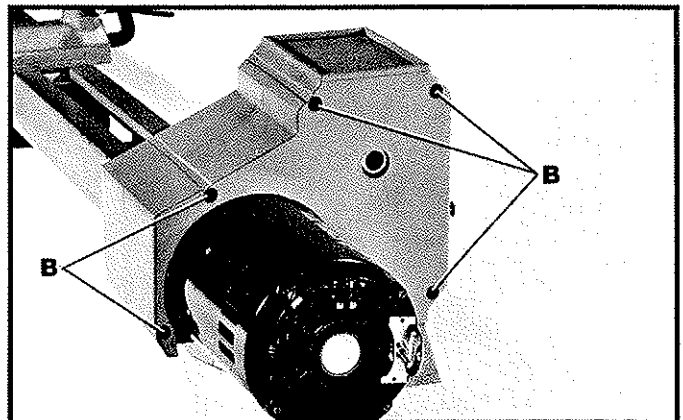

Fig. 88

5. Turn variable speed control handle (C) Fig. 89, counterclockwise to loosen tension on belt (D).

6. Remove three screws (E) Fig. 89. **CAUTION: CARE MUST BE TAKEN TO SUPPORT THE MOTOR WHEN REMOVING SCREWS (E) AS MOTOR BRACKET AND MOTOR WILL FALL FROM HEADSTOCK AND MOTOR PULLEY WILL SEPARATE.**

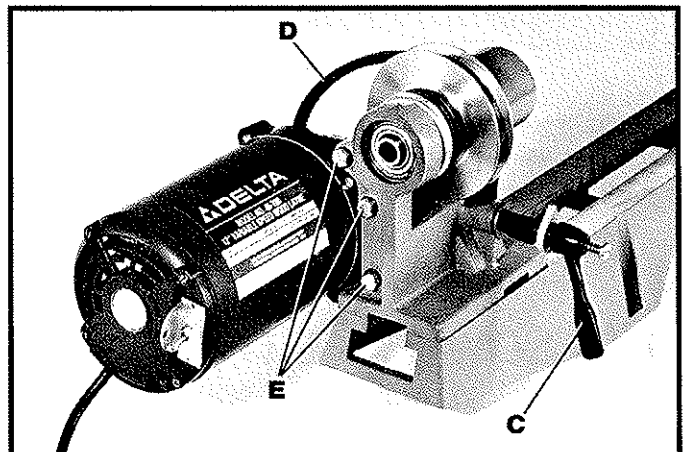

Fig. 89

7. Fig. 90, illustrates the motor and motor bracket (F) removed from headstock and motor pulley half (G) removed from motor shaft.

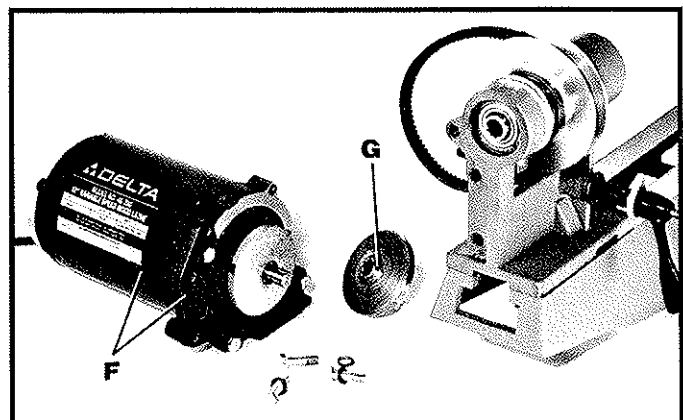

Fig. 90



8. Indicate the location of the spindle pulley hub (H), Fig. 91, on spindle (K) using a pencil. Then loosen set screw (L) and move spindle pulley half (J) to the left as shown and retighten set screw (L). **CAUTION: CARE MUST BE TAKEN TO HOLD PULLEY HALF (J) TO THE LEFT WHEN LOOSENING SCREW (L) AS THERE IS CONSIDERABLE SPRING PRESSURE, WHICH WILL MOVE THE PULLEY HALVES TO THE RIGHT.**

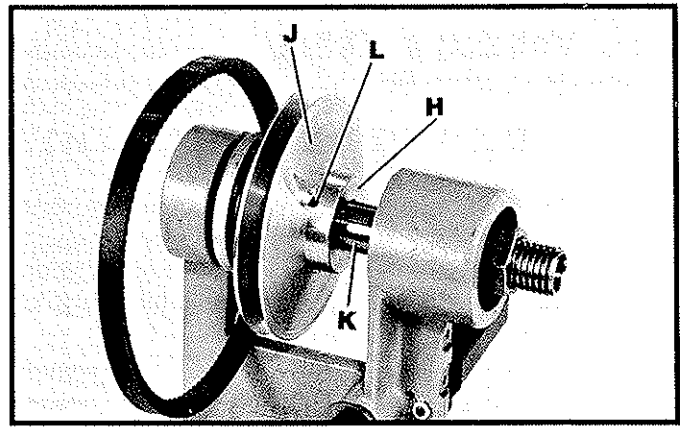

Fig. 91

9. Remove snap ring (M) Fig. 92, and spring washer (N) from inboard end of spindle.

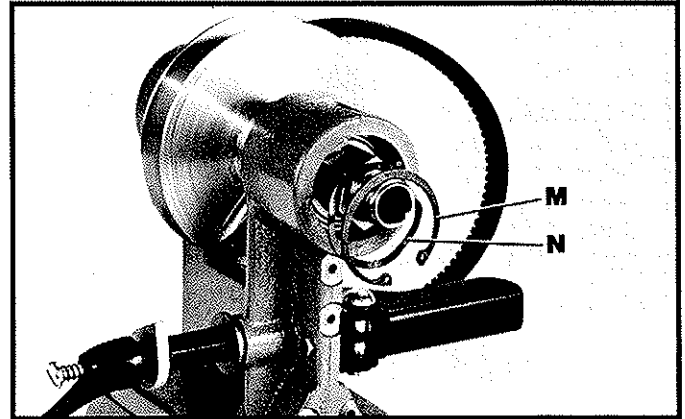

Fig. 92

10. Push spindle assembly (O) Fig. 93, to the right as shown to provide clearance enabling you to remove the belt (D). It may be necessary to tap on the left end of the spindle with a dowel rod to move spindle.

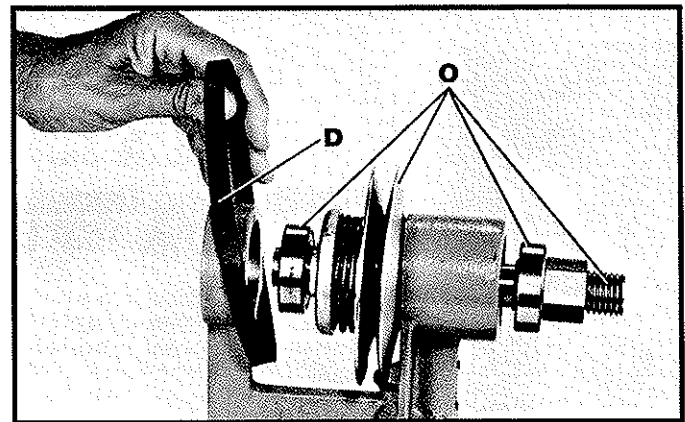

Fig. 93

12. Fig. 94, illustrates the spindle assembly replaced in the headstock. Loosen set screw (L) and move pulley hub (H) to the mark made on the spindle (K) in **STEP 8** and tighten set screw (L). **CAUTION: CARE MUST BE TAKEN WHEN LOOSENING SCREW (L) AS THERE IS CONSIDERABLE SPRING PRESSURE WHICH WILL MOVE THE PULLEY HALVES TO THE RIGHT.** After set screw (L) is tightened, manually move pulley half (P) to the left as far as possible and push belt down between pulley halves. This will provide sufficient slack in the belt when assembling belt to motor pulley.

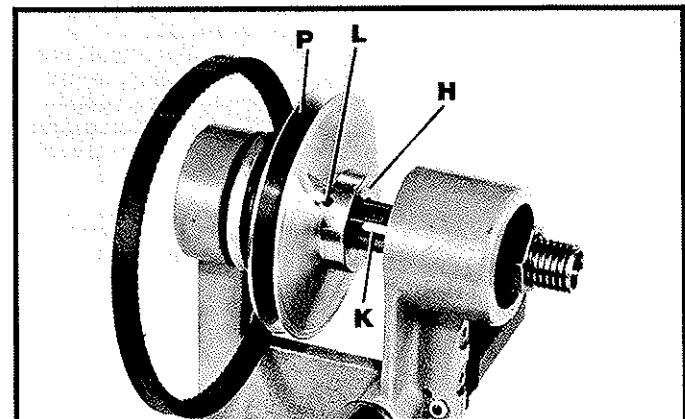

Fig. 94

13. Reassemble the complete headstock assembly by reversing **STEPS 2** thru **9**.



## PARTS, SERVICE OR WARRANTY ASSISTANCE

All Delta Machines and accessories are manufactured to high quality standards and are serviced by a network of factory service centers and authorized service stations listed in your owner's manual. To obtain additional infor-

mation regarding your Delta quality product or to obtain parts, service or warranty assistance, please call or fax Delta's toll-free 'hotline' number.

Delta maintains a modern, efficient Parts Distribution Center, maintaining an inventory of over 15,000 parts located in Memphis, Tennessee.

Highly qualified and experienced Customer Service Representatives are standing by to assist you on weekdays from 8:00 A.M. to 5:00 P.M. Memphis time.

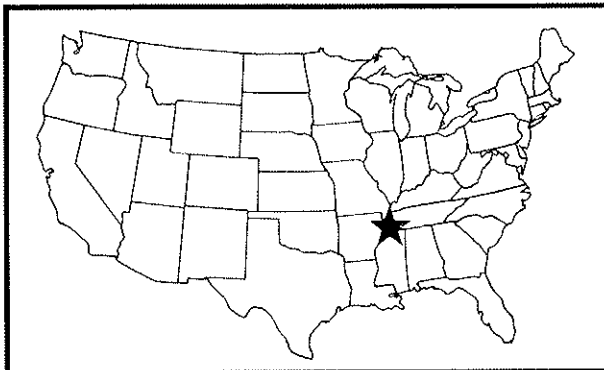

Memphis, TN 38118  
4290 Raines Road  
Phone: (901) 363-8800

**HOTLINE**  
800-223-PART  
FAX: 800-535-6488



### Delta Building Trades and Home Shop Machinery Two Year Limited Warranty

Delta will repair or replace, at its expense and at its option, any Delta machine, machine part, or machine accessory which in normal use has proven to be defective in workmanship or material, provided that the customer returns the product prepaid to a Delta factory service center or authorized service station with proof of purchase of the product within two years and provides Delta with reasonable opportunity to verify the alleged defect by inspection. Delta may require that electric motors be returned prepaid to a motor manufacturer's authorized station for inspection and repair or replacement. Delta will not be responsible for any asserted defect which has resulted from normal wear, misuse, abuse or repair or alteration made or specifically authorized by anyone other than an authorized Delta service facility or representative. Under no circumstances will Delta be liable for incidental or consequential damages resulting from defective products. This warranty is Delta's sole warranty and sets forth the customer's exclusive remedy, with respect to defective products; all other warranties, express or implied, whether of merchantability, fitness for purpose, or otherwise, are expressly disclaimed by Delta.

## Free Manuals Download Website

<http://myh66.com>

<http://usermanuals.us>

<http://www.somanuals.com>

<http://www.4manuals.cc>

<http://www.manual-lib.com>

<http://www.404manual.com>

<http://www.luxmanual.com>

<http://aubethermostatmanual.com>

Golf course search by state

<http://golfingnear.com>

Email search by domain

<http://emailbydomain.com>

Auto manuals search

<http://auto.somanuals.com>

TV manuals search

<http://tv.somanuals.com>