

Dell™ PowerVault™ DL2000

# Hardware Owner's Manual

# Notes, Notices, and Cautions



**NOTE:** A NOTE indicates important information that helps you make better use of your computer.



**NOTICE:** A NOTICE indicates either potential damage to hardware or loss of data and tells you how to avoid the problem.



**CAUTION:** A CAUTION indicates a potential for property damage, personal injury, or death.

---

**Information in this document is subject to change without notice.**

**© 2008 Dell Inc. All rights reserved.**

Reproduction of these materials in any manner whatsoever without the written permission of Dell Inc. is strictly forbidden.

Trademarks used in this text: *Dell*, the *DELL* logo, *PowerEdge*, and *PowerVault* are trademarks of Dell Inc.; *Intel* and *Xeon* are registered trademarks of Intel Corporation in the U.S. and other countries; *Microsoft*, *Windows*, and *Windows Server* are either trademarks or registered trademarks of Microsoft Corporation in the United States and/or other countries.

Other trademarks and trade names may be used in this document to refer to either the entities claiming the marks and names or their products. Dell Inc. disclaims any proprietary interest in trademarks and trade names other than its own.

Model EMS01

September 2009

Rev. A01

# Contents

1	About Your System . . . . .	11
	<b>Other Information You May Need</b> . . . . .	11
	<b>Accessing System Features During Startup</b> . . . . .	12
	<b>Front-Panel Features and Indicators</b> . . . . .	13
	Hard-Drive Indicator Codes . . . . .	15
	<b>Back-Panel Features and Indicators</b> . . . . .	17
	Connecting External Devices . . . . .	18
	<b>Power Indicator Codes</b> . . . . .	18
	<b>NIC Indicator Codes</b> . . . . .	19
	<b>LCD Status Messages</b> . . . . .	20
	Solving Problems Described by LCD Status Messages . . . . .	31
	Removing LCD Status Messages . . . . .	31
	<b>System Messages</b> . . . . .	32
	<b>Warning Messages</b> . . . . .	43
	<b>Diagnostics Messages</b> . . . . .	44
	<b>Alert Messages</b> . . . . .	44
2	Using the System Setup Program . . . . .	45
	<b>Entering the System Setup Program</b> . . . . .	45

Responding to Error Messages . . . . .	45
Using the System Setup Program . . . . .	46
<b>System Setup Options . . . . .</b>	<b>46</b>
Main Screen . . . . .	46
Memory Information Screen . . . . .	49
CPU Information Screen . . . . .	50
Integrated Devices Screen . . . . .	51
Serial Communication Screen . . . . .	53
System Security Screen . . . . .	53
Exit Screen . . . . .	56
<b>System and Setup Password Features . . . . .</b>	<b>56</b>
Using the System Password . . . . .	56
Using the Setup Password . . . . .	59
<b>Disabling a Forgotten Password . . . . .</b>	<b>60</b>
<b>Baseboard Management Controller Configuration . . . . .</b>	<b>61</b>
Entering the BMC Setup Module . . . . .	61
BMC Setup Module Options . . . . .	61
<b>3 Installing System Components . . . . .</b>	<b>63</b>
<b>Recommended Tools . . . . .</b>	<b>63</b>
<b>Inside the System . . . . .</b>	<b>64</b>
<b>Front Bezel . . . . .</b>	<b>65</b>
Removing the Front Bezel . . . . .	65
Replacing the Front Bezel . . . . .	66
<b>Opening and Closing the System . . . . .</b>	<b>66</b>
Opening the System . . . . .	67
Closing the System . . . . .	67

<b>Hard Drives</b> . . . . .	<b>68</b>
Before You Begin . . . . .	69
Removing a Drive Blank . . . . .	69
Installing a Drive Blank . . . . .	70
Removing a Hot-Plug Hard Drive . . . . .	70
Installing a Hot-Plug Hard Drive . . . . .	70
<b>Replacing a Hard-Drive Carrier</b> . . . . .	<b>72</b>
Removing a Hard Drive From a Hard-Drive Carrier . . . . .	72
Installing a SATA Hard Drive Into a SATA Drive Carrier . . . . .	72
Installing a SATA Hard Drive and Interposer Card Into a SATAu Hard-Drive Carrier . . . . .	73
<b>Power Supplies</b> . . . . .	<b>76</b>
Removing a Power Supply . . . . .	76
Replacing a Power Supply . . . . .	77
Removing the Power Supply Blank . . . . .	78
Installing the Power Supply Blank . . . . .	78
<b>System Fans</b> . . . . .	<b>78</b>
Removing a System Fan . . . . .	78
Replacing a Cooling Fan . . . . .	79
<b>Cooling Shroud</b> . . . . .	<b>80</b>
Removing the Cooling Shroud . . . . .	80
Installing the Cooling Shroud . . . . .	81
<b>Fan Brackets</b> . . . . .	<b>81</b>
Removing the Fan Bracket . . . . .	81
Replacing the Fan Bracket . . . . .	82
<b>Cable Routing</b> . . . . .	<b>83</b>
Removing the Cable Retention Bracket . . . . .	83
Installing the Cable Retention Bracket . . . . .	84

<b>SAS Controller Daughter Card</b> . . . . .	<b>85</b>
Installing a SAS Controller Daughter Card . . . . .	85
SAS Controller Daughter Card Cabling Guidelines . . . . .	87
Removing a SAS Controller Daughter Card . . . . .	87
<b>Configuring the Boot Device</b> . . . . .	<b>87</b>
<b>Expansion Cards</b> . . . . .	<b>88</b>
Expansion Card Installation Guidelines . . . . .	88
Installing an Expansion Card . . . . .	88
Removing an Expansion Card . . . . .	90
<b>Expansion-Card Cage</b> . . . . .	<b>91</b>
Removing the Expansion-Card Cage . . . . .	91
Replacing the Expansion-Card Cage . . . . .	93
<b>DRAC Card and Cables</b> . . . . .	<b>93</b>
Installing the DRAC Card and Cables . . . . .	93
Removing the DRAC Card and Cables . . . . .	95
<b>Optical Drive and Cable</b> . . . . .	<b>96</b>
Removing the Optical Drive . . . . .	96
Installing the Optical Drive . . . . .	97
Removing the Optical Drive Cable . . . . .	99
Installing the Optical Drive Cable . . . . .	99
<b>System Memory</b> . . . . .	<b>100</b>
General Memory Module Installation Guidelines . . . . .	100
Non-Optimal Memory Configurations . . . . .	101
Memory Sparing Support . . . . .	101
Memory Mirroring Support . . . . .	101
Installing Memory Modules . . . . .	102
Removing Memory Modules . . . . .	104

<b>Activating the Integrated NIC TOE . . . . .</b>	<b>105</b>
<b>Processors . . . . .</b>	<b>105</b>
Removing a Processor . . . . .	105
Installing a Processor . . . . .	108
<b>System Battery . . . . .</b>	<b>110</b>
Replacing the System Battery . . . . .	110
<b>Expansion-Card Riser Boards . . . . .</b>	<b>112</b>
Removing the Left Expansion-Card Riser Board . . . . .	112
Installing the Left Riser Board . . . . .	113
Removing the Central Riser Board . . . . .	114
Installing the Central Riser Board . . . . .	115
<b>Sideplane Board . . . . .</b>	<b>116</b>
Removing the Sideplane Board . . . . .	116
Installing the Sideplane Board . . . . .	118
<b>SAS Backplane Board . . . . .</b>	<b>118</b>
Removing the SAS Backplane Board . . . . .	118
Installing the SAS Backplane Board . . . . .	120
<b>Control Panel Assembly (Service-only Procedure) . . . . .</b>	<b>122</b>
Removing the Control Panel Assembly . . . . .	122
Installing the Control Panel Assembly . . . . .	123
<b>System Board (Service-only Procedure) . . . . .</b>	<b>124</b>
Removing the System Board . . . . .	124
Installing the System Board . . . . .	127
<b>4 Troubleshooting Your System . . . . .</b>	<b>129</b>
<b>Safety First—For You and Your System . . . . .</b>	<b>129</b>

<b>Start-Up Routine . . . . .</b>	<b>129</b>
<b>Checking the Equipment. . . . .</b>	<b>130</b>
Troubleshooting IRQ Assignment Conflicts . . . . .	130
Troubleshooting External Connections . . . . .	131
Troubleshooting the Video Subsystem . . . . .	131
Troubleshooting the Keyboard . . . . .	132
Troubleshooting the Mouse . . . . .	133
<b>Troubleshooting Basic I/O Functions . . . . .</b>	<b>133</b>
Troubleshooting a Serial I/O Device . . . . .	134
Troubleshooting a USB Device . . . . .	134
<b>Troubleshooting a NIC . . . . .</b>	<b>136</b>
<b>Troubleshooting a Wet System . . . . .</b>	<b>137</b>
<b>Troubleshooting a Damaged System . . . . .</b>	<b>138</b>
<b>Troubleshooting the System Battery . . . . .</b>	<b>138</b>
<b>Troubleshooting Power Supplies . . . . .</b>	<b>139</b>
<b>Troubleshooting System Cooling Problems . . . . .</b>	<b>140</b>
Troubleshooting a Fan . . . . .	141
<b>Troubleshooting System Memory . . . . .</b>	<b>142</b>
<b>Troubleshooting an Optical Drive . . . . .</b>	<b>143</b>
<b>Troubleshooting an External SCSI Tape Drive . . . . .</b>	<b>144</b>
<b>Troubleshooting a Hard Drive . . . . .</b>	<b>146</b>
<b>Troubleshooting a SAS Controller Daughter Card . . . . .</b>	<b>147</b>
<b>Troubleshooting Expansion Cards . . . . .</b>	<b>149</b>
<b>Troubleshooting the Microprocessors . . . . .</b>	<b>150</b>



<b>5</b>	<b>Running the System Diagnostics</b>	<b>153</b>
	<b>Using Server Administrator Diagnostics</b>	<b>153</b>
	<b>System Diagnostics Features</b>	<b>153</b>
	<b>When to Use the System Diagnostics</b>	<b>154</b>
	<b>Running the System Diagnostics</b>	<b>154</b>
	<b>System Diagnostics Testing Options</b>	<b>154</b>
	<b>Using the Custom Test Options</b>	<b>155</b>
	Selecting Devices for Testing	155
	Selecting Diagnostics Options	155
	Viewing Information and Results	156
<b>6</b>	<b>Jumpers and Connectors</b>	<b>157</b>
	<b>System Board Jumpers</b>	<b>157</b>
	<b>System Board Connectors</b>	<b>158</b>
	<b>SAS Backplane Board Connectors</b>	<b>161</b>
	<b>Sideplane Board Connectors</b>	<b>162</b>
	<b>Expansion-Card Riser-Board Components and     PCI Buses</b>	<b>162</b>
	<b>Disabling a Forgotten Password</b>	<b>164</b>
<b>7</b>	<b>Getting Help</b>	<b>167</b>
	<b>Contacting Dell</b>	<b>167</b>

Glossary . . . . .	169
Index . . . . .	181

# About Your System

This section describes the physical, firmware, and software interface features that provide and ensure the essential functioning of your system. The physical connectors on your system's front and back panels provide convenient connectivity and system expansion capability. The system firmware, applications, and operating systems monitor the system and component status and alert you when a problem arises. System conditions can be reported by any of the following:

- Front or back panel indicators
- System messages
- Warning messages
- Diagnostics messages
- Alert messages

This section describes each type of message, lists the possible causes, and provides steps to resolve any problems indicated by a message. The system indicators and features are illustrated in this section.

## Other Information You May Need



**CAUTION: Many repairs may only be done by a certified service technician. You should only perform troubleshooting and simple repairs as authorized in your product documentation, or as directed by the online or telephone service and support team. Damage due to servicing that is not authorized by Dell is not covered by your warranty. Read and follow the safety instructions that came with the product.**

- The *Rack Installation Guide* included with your rack solution describes how to install your system into a rack.
- The *Getting Started Guide* provides an overview of system features, setting up your system, and technical specifications.
- CDs and DVDs included with your system provide documentation and tools for configuring and managing your system.
- Systems management software documentation describes the features, requirements, installation, and basic operation of the software.

- Operating system documentation describes how to install (if necessary), configure, and use the operating system software.
- Documentation for any components you purchased separately provides information to configure and install these options.
- Updates are sometimes included with the system to describe changes to the system, software, and/or documentation.



**NOTE:** Always check for updates on [support.dell.com](http://support.dell.com) and read the updates first because they often supersede information in other documents.

- Release notes or readme files may be included to provide last-minute updates to the system or documentation or advanced technical reference material intended for experienced users or technicians.

## Accessing System Features During Startup

Table 1-1 describes keystrokes that may be entered during startup to access system features. If your operating system begins to load before you enter the keystroke, allow the system to finish booting, and then restart your system and try again.

**Table 1-1. Keystrokes for Accessing System Features**

Keystroke	Description
<F2>	Enters the System Setup program. See "Using the System Setup Program" on page 46.
<F10>	Opens the utility partition, allowing you to run the system diagnostics. See "Running the System Diagnostics" on page 153
<Ctrl+E>	Enters the Baseboard Management Controller (BMC) Management Utility, which allows access to the system event log (SEL). See the <i>BMC User's Guide</i> for more information on setup and use of BMC.
<Ctrl+C>	Enters the SAS Configuration Utility. See your SAS adapter <i>User's Guide</i> for more information.
<Ctrl+R>	Enters the RAID configuration utility, which allows you to configure a RAID card. For more information, see the documentation for your RAID card.

**Table 1-1. Keystrokes for Accessing System Features (continued)**

Keystroke	Description
<Ctrl+S>	Option is displayed only if you have PXE support enabled through the System Setup Program (see "Integrated Devices Screen" on page 51). This keystroke allows you to configure NIC settings for PXE boot. For more information, see the documentation for your integrated NIC.
<Ctrl+D>	If you have the optional Dell Remote Access Controller (DRAC), this keystroke allows access to selected DRAC configuration settings. See the DRAC User's Guide for more information on setup and use of DRAC.



## Front-Panel Features and Indicators

Figure 1-1 shows the controls, indicators, and connectors located behind the optional rack bezel on the system's front panel.

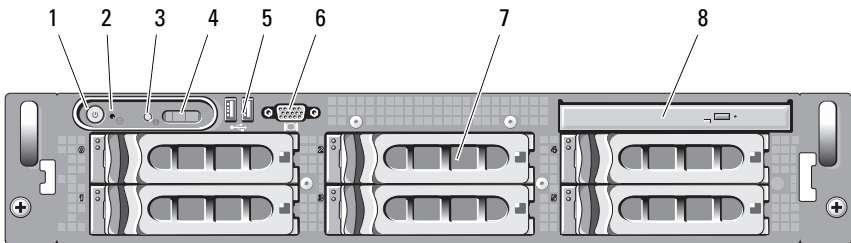

**Figure 1-1. Front-Panel Features and Indicators**



**Table 1-2. Front-Panel LED Indicators, Buttons, and Connectors**

Item	Indicator, Button, or Connector	Icon	Description
1	Power-on indicator, power button		<p>The power-on indicator lights when the system power is on.</p> <p>The power button controls the DC power supply output to the system.</p> <p><b>NOTE:</b> If you turn off the system using the power button and the system is running an ACPI-compliant operating system, the system performs a graceful shutdown before the power is turned off. If the system is not running an ACPI-compliant operating system, the power is turned off immediately after the power button is pressed.</p>
2	NMI button		<p>Used to troubleshoot software and device driver errors when using certain operating systems. This button can be pressed using the end of a paper clip.</p> <p>Use this button only if directed to do so by qualified support personnel or by the operating system's documentation.</p>
3	System identification button		<p>The identification buttons on the front and back panels can be used to locate a particular system within a rack. When one of these buttons is pushed, the LCD panel on the front and the blue system status indicator on the back blink until one of the buttons is pushed again.</p>

**Table 1-2. Front-Panel LED Indicators, Buttons, and Connectors (continued)**

Item	Indicator, Button, or Connector	Icon	Description
4	LCD panel		<p>Provides system ID, status information, and system error messages.</p> <p>The LCD lights during normal system operation. Both the systems management software and the identification buttons located on the front and back of the system can cause the LCD to flash blue to identify a particular system.</p> <p>The LCD lights amber when the system needs attention, and the LCD panel displays an error code followed by descriptive text.</p> <p><b>NOTE:</b> If the system is connected to AC power and an error has been detected, the LCD lights amber regardless of whether the system has been powered on.</p>
5	USB connectors (2)		Connects USB 2.0-compliant devices to the system.
6	Video connector		Connects a monitor to the system.
7	Hard drives (4)		Four 3.5-inch hot-plug
8	Optical drive		One slimline SATA DVD drive.

### Hard-Drive Indicator Codes

The hard-drive carriers have two indicators—the drive-activity indicator and the drive-status indicator. See Figure 1-2. In RAID configurations, the drive-status indicator lights to indicate the status of the drive. In non-RAID configurations, only the drive-activity indicator lights; the drive-status indicator is off.

**Figure 1-2. Hard-Drive Indicators**

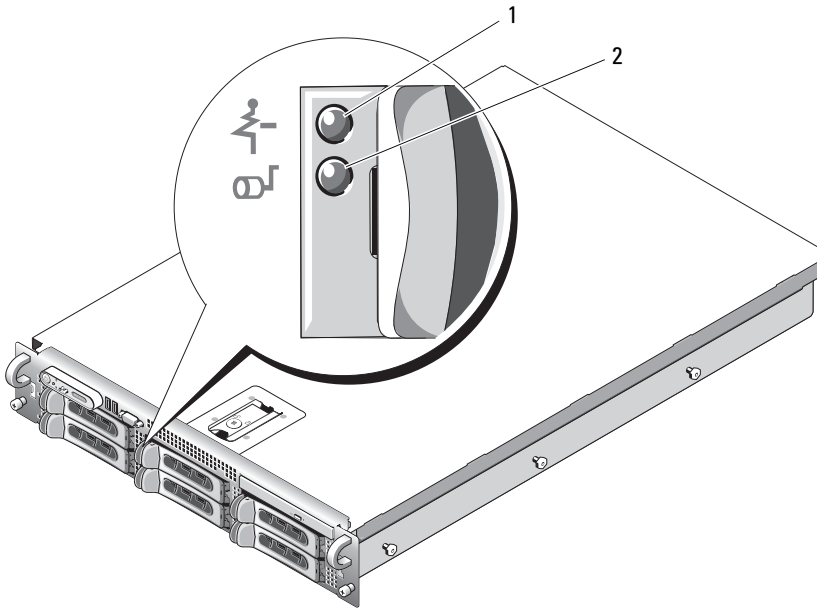

- 1 drive-status indicator (green and amber)
- 2 green drive-activity indicator

Table 1-3 lists the drive indicator patterns for RAID hard drives. Different patterns are displayed as drive events occur in the system. For example, if a hard drive fails, the "drive failed" pattern appears. After the drive is selected for removal, the "drive being prepared for removal" pattern appears, followed by the "drive ready for insertion or removal" pattern. After the replacement drive is installed, the "drive being prepared for operation" pattern appears, followed by the "drive online" pattern.

**NOTE:** For non-RAID configurations, only the drive-activity indicator is active. The drive-status indicator is off.

**Table 1-3. Hard-Drive Indicator Patterns for RAID**

Condition	Drive-Status Indicator Pattern
Identify drive/preparing for removal	Blinks green two times per second



**Table 1-3. Hard-Drive Indicator Patterns for RAID (continued)**

Condition	Drive-Status Indicator Pattern
Drive ready for insertion or removal	Off
Drive predicted failure	Blinks green, amber, and off.
Drive failed	Blinks amber four times per second.
Drive rebuilding	Blinks green slowly.
Drive online	Steady green.
Rebuild aborted	Blinks green three seconds, amber three seconds, and off six seconds.

## Back-Panel Features and Indicators

Figure 1-3 shows the controls, indicators, and connectors located on the system's back panel.

**Figure 1-3. Back-Panel Features and Indicators**

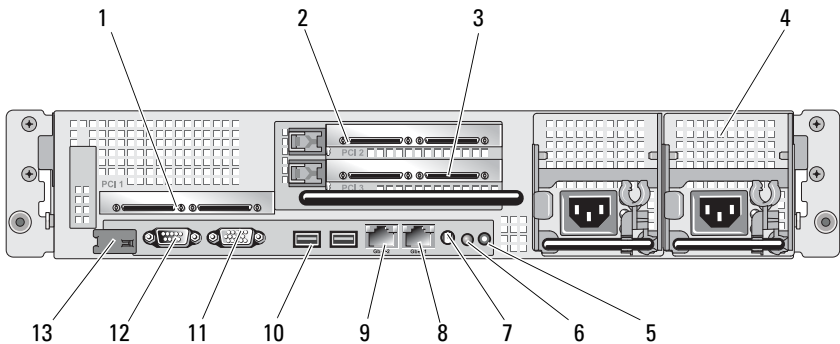

- |   |                              |    |                         |
|---|------------------------------|----|-------------------------|
| 1 | center PCI riser (slot 1)    | 2  | left PCI riser (slot 2) |
| 3 | left PCI riser (slot 3)      | 4  | power supplies (2)      |
| 5 | system identification button | 6  | system status indicator |
| 7 | system status indicator      | 8  | NIC2 connector          |
| 9 | NIC1 connector               | 10 | USB connectors (2)      |

11 video connector

12 serial connector

13 Dell remote access controller  
(optional)

## Connecting External Devices

When connecting external devices to your system, follow these guidelines:

- Most devices must be connected to a specific connector and device drivers must be installed before the device operates properly. (Device drivers are normally included with your operating system software or with the device itself.) See the documentation that accompanied the device for specific installation and configuration instructions.
- Always attach external devices while your system and the device are turned off. Next, turn on any external devices before turning on the system (unless the documentation for the device specifies otherwise).

For information about individual connectors, see "Jumpers and Connectors" on page 157. For information about enabling, disabling, and configuring I/O ports and connectors, see "Using the System Setup Program" on page 45.

## Power Indicator Codes

The power button on the front panel controls the power input to the system's power supplies. The power indicator lights green when the system is on.

The indicators on the redundant power supplies show whether power is present or whether a power fault has occurred (see Figure 1-4). Table 1-4 lists the power supply indicator codes.

**Table 1-4. Redundant Power Supply Indicators**

Indicator	Function
Power supply status	Green indicates that the power supply is operational.
Power supply fault	Amber indicates a problem with the power supply.
AC line status	Green indicates that a valid AC source is connected to the power supply.

**Figure 1-4. Redundant Power Supply Indicators**

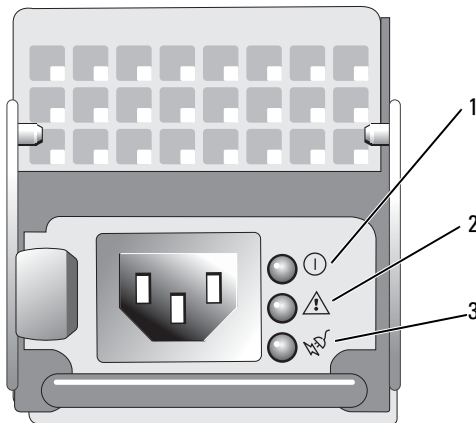

- 1 power supply status
- 2 power supply fault
- 3 AC line status

## NIC Indicator Codes

Each NIC on the back panel has an indicator that provides information on network activity and link status. See Figure 1-5. Table 1-5 lists the NIC indicator codes.

**Figure 1-5. NIC Indicators**

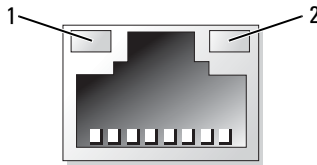

1 link indicator      2 activity indicator

**Table 1-5. NIC Indicator Codes**

Indicator	Indicator Code
Link and activity indicators are off	The NIC is not connected to the network.
Link indicator is green	The NIC is connected to a valid link partner on the network.
Activity indicator is amber blinking	Network data is being sent or received.

## LCD Status Messages

The system's control panel LCD provides status messages to signify when the system is operating correctly or when the system needs attention.

The LCD lights blue to indicate a normal operating condition, and lights amber to indicate an error condition. The LCD scrolls a message that includes a status code followed by descriptive text. Table 1-6 lists the LCD status messages that can occur and the probable cause for each message. The LCD messages refer to events recorded in the System Event Log (SEL). For information on the SEL and configuring system management settings, see the systems management software documentation.

**⚠ CAUTION: Many repairs may only be done by a certified service technician. You should only perform troubleshooting and simple repairs as authorized in your product documentation, or as directed by the online or telephone service and support team. Damage due to servicing that is not authorized by Dell is not covered by your warranty. Read and follow the safety instructions that came with the product.**



**NOTE:** If your system fails to boot, press the System ID button for at least five seconds until an error code appears on the LCD. Record the code, then see "Getting Help" on page 167.

**Table 1-6. LCD Status Messages**

<b>Code</b>	<b>Text</b>	<b>Causes</b>	<b>Corrective Actions</b>
<i>N/A</i>	<i>SYSTEM NAME</i>	<p>A 62-character string that can be defined by the user in the System Setup program.</p> <p>The <i>SYSTEM NAME</i> displays under the following conditions:</p> <ul style="list-style-type: none"> <li>• The system is powered on.</li> <li>• The power is off and active POST errors are displayed.</li> </ul>	<p>This message is for information only.</p> <p>You can change the system ID and name in the System Setup program. See "Using the System Setup Program" on page 45.</p>
E1000	FAILSAFE, Call Support		See "Getting Help" on page 167.
E1114	Temp Ambient	Ambient system temperature is out of acceptable range.	See "Troubleshooting System Cooling Problems" on page 140.
E1116	Temp Memory	Memory has exceeded acceptable temperature and has been disabled to prevent damage to the components.	See "Troubleshooting System Cooling Problems" on page 140.
E12nn	xx PwrGd	Specified voltage regulator has failed.	See "Getting Help" on page 167.
E1210	CMOS Batt	CMOS battery is missing, or the voltage is out of acceptable range.	See "Troubleshooting the System Battery" on page 138.
E1229	CPU # VCORE	Processor # VCORE voltage regulator has failed.	See "Getting Help" on page 167.

**Table 1-6. LCD Status Messages (continued)**

<b>Code</b>	<b>Text</b>	<b>Causes</b>	<b>Corrective Actions</b>
E1310	RPM Fan ##	RPM of specified cooling fan is out of acceptable operating range.	See "Troubleshooting System Cooling Problems" on page 140.
E1313	Fan Redundancy	The system is no longer fan-redundant. Another fan failure will put the system at risk of overheating.	Check control panel LCD for additional scrolling messages. See "Troubleshooting System Cooling Problems" on page 140.
E1410	CPU # IERR	Specified microprocessor is reporting an internal error.	See your system's <i>Information Update Tech Sheet</i> located on <a href="http://support.dell.com">support.dell.com</a> for the most current system information. If problem persists, see "Getting Help" on page 167.

**Table 1-6. LCD Status Messages (continued)**

<b>Code</b>	<b>Text</b>	<b>Causes</b>	<b>Corrective Actions</b>
E1414	CPU # Thermtrip	Specified microprocessor is out of acceptable temperature range and has halted operation.	See "Troubleshooting System Cooling Problems" on page 140. If the problem persists, ensure that the microprocessor heat sinks are properly installed. See "Troubleshooting the Microprocessors" on page 150.  <b>NOTE:</b> The LCD continues to display this message until the system's power cord is disconnected and reconnected to the AC power source, or the SEL is cleared using either Server Assistant or the BMC Management Utility. See the <i>Dell OpenManage Baseboard Management Controller User's Guide</i> for information about these utilities.
E1418	CPU # Presence	Specified processor is missing or bad, and the system is in an unsupported configuration.	See "Troubleshooting the Microprocessors" on page 150.
E141C	CPU Mismatch	Processors are in a configuration unsupported by Dell.	Ensure that your processors match and conform to the type described in the Microprocessor Technical Specifications outlined in your system's <i>Getting Started Guide</i> .

**Table 1-6. LCD Status Messages (continued)**

<b>Code</b>	<b>Text</b>	<b>Causes</b>	<b>Corrective Actions</b>
E141F	CPU Protocol	The system BIOS has reported a processor protocol error.	See "Getting Help" on page 167.
E1420	CPU Bus PERR	The system BIOS has reported a processor bus parity error.	See "Getting Help" on page 167.
E1421	CPU Init	The system BIOS has reported a processor initialization error.	See "Getting Help" on page 167.
E1422	CPU Machine Chk	The system BIOS has reported a machine check error.	See "Getting Help" on page 167.
E1610	PS # Missing	No power is available from the specified power supply; specified power supply is improperly installed or faulty.	See "Troubleshooting Power Supplies" on page 139.
E1614	PS # Status	No power is available from the specified power supply; specified power supply is improperly installed or faulty.	See "Troubleshooting Power Supplies" on page 139.
E1618	PS # Predictive	Power supply voltage is out of acceptable range; specified power supply is improperly installed or faulty.	See "Troubleshooting Power Supplies" on page 139.
E161C	PS # Input Lost	Power source for specified power supply is unavailable, or out of acceptable range.	Check the AC power source for the specified power supply. If problem persists, see "Troubleshooting Power Supplies" on page 139.



**Table 1-6. LCD Status Messages (continued)**

<b>Code</b>	<b>Text</b>	<b>Causes</b>	<b>Corrective Actions</b>
E1620	PS # Input Range	Power source for specified power supply is unavailable, or out of acceptable range.	Check the AC power source for the specified power supply. If problem persists, see "Troubleshooting Power Supplies" on page 139.
E1624	PS Redundancy	The power supply subsystem is no longer redundant. If the last supply fails, the system will go down.	See "Troubleshooting Power Supplies" on page 139.
E1710	I/O Channel Chk	The system BIOS has reported an I/O channel check.	See "Getting Help" on page 167.
E1711	PCI PERR B## D## F## PCI PERR Slot #	The system BIOS has reported a PCI parity error on a component that resides in PCI configuration space at bus ##, device ##, function ##.  The system BIOS has reported a PCI parity error on a component that resides in the specified PCI slot.	Remove and reseat the PCI expansion cards. If the problem persists, see "Troubleshooting Expansion Cards" on page 149.  Reinstall the expansion-card cage. See "Expansion-Card Cage" on page 91.  If the problem persists, the riser card or system board is faulty. See "Getting Help" on page 167.

**Table 1-6. LCD Status Messages (continued)**

<b>Code</b>	<b>Text</b>	<b>Causes</b>	<b>Corrective Actions</b>
E1712	PCI SERR B## D## F## PCI SERR Slot #	The system BIOS has reported a PCI system error on a component that resides in PCI configuration space at bus ##, device ##, function ##.  The system BIOS has reported a PCI system error on a component that resides in the specified slot.	Remove and reseal the PCI expansion cards. If the problem persists, see "Troubleshooting Expansion Cards" on page 149.  Reinstall the expansion-card cage. See "Expansion-Card Cage" on page 91.  If the problem persists, the riser card or system board is faulty. See "Getting Help" on page 167.
E1714	Unknown Err	The system BIOS has determined that there has been an error in the system, but is unable to determine its origin.	See "Getting Help" on page 167.
E171F	PCIE Fatal Err B## D## F## PCIE Fatal Err Slot #	The system BIOS has reported a PCIe fatal error on a component that resides in PCI configuration space at bus ##, device ##, function ##.  The system BIOS has reported a PCIe fatal error on a component that resides in the specified slot.	Remove and reseal the PCI expansion cards. If the problem persists, see "Troubleshooting Expansion Cards" on page 149.  Reinstall the expansion-card cage. See "Expansion-Card Cage" on page 91.  If the problem persists, the riser card or system board is faulty. See "Getting Help" on page 167.
E1810	HDD ## Fault	The SAS subsystem has determined that hard drive ## has experienced a fault.	See "Troubleshooting a Hard Drive" on page 146.

**Table 1-6. LCD Status Messages (continued)**

<b>Code</b>	<b>Text</b>	<b>Causes</b>	<b>Corrective Actions</b>
E1811	HDD ## Rbld Abrt	The specified hard drive has experienced a rebuild abort.	See "Troubleshooting a Hard Drive" on page 146. If the problem persists, see your RAID documentation.
E1812	HDD ## Removed	The specified hard drive has been removed from the system.	Information only.
E1913	CPU & Firmware Mismatch	The BMC firmware does not support the CPU.	Update to the latest BMC firmware. See the <i>BMC User's Guide</i> for more information on setup and use of BMC.
E1A11	PCI Rsr Config	PCI risers are not configured correctly; some invalid configurations may prevent the system from powering on.	See "Expansion-Card Riser Boards" on page 112.
E1A12	PCI Rsr Missing	One or all of the PCI risers is missing, preventing the system from powering on.	Information only.
E1A14	SAS Cable A	SAS cable A is missing or bad.	Reseat the cable. If problem persists, replace cable. See "SAS Controller Daughter Card" on page 85.
E1A15	SAS Cable B	SAS cable B is missing or bad.	Reseat the cable. If problem persists, replace cable. See "SAS Controller Daughter Card" on page 85.
E2010	No Memory	No memory is installed in the system.	Install memory. See "Installing Memory Modules" on page 102.

**Table 1-6. LCD Status Messages (continued)**

<b>Code</b>	<b>Text</b>	<b>Causes</b>	<b>Corrective Actions</b>
E2011	Mem Config Err	Memory detected, but is not configurable. Error detected during memory configuration.	See "Troubleshooting System Memory" on page 142.
E2012	Unusable Memory	Memory is configured, but not usable. Memory subsystem failure.	See "Troubleshooting System Memory" on page 142.
E2013	Shadow BIOS Fail	The system BIOS failed to copy its flash image into memory.	See "Troubleshooting System Memory" on page 142.
E2014	CMOS Fail	CMOS failure. CMOS RAM not functioning properly.	See "Getting Help" on page 167.
E2015	DMA Controller	DMA controller failure.	See "Getting Help" on page 167.
E2016	Int Controller	Interrupt controller failure.	See "Getting Help" on page 167.
E2017	Timer Fail	Timer refresh failure.	See "Getting Help" on page 167.
E2018	Prog Timer	Programmable interval timer error.	See "Getting Help" on page 167.
E2019	Parity Error	Parity error.	See "Getting Help" on page 167.
E201A	SIO Err	SIO failure.	See "Getting Help" on page 167.
E201B	Kybd Controller	Keyboard controller failure.	See "Getting Help" on page 167.
E201C	SMI Init	System management interrupt (SMI) initialization failure.	See "Getting Help" on page 167.
E201D	Shutdown Test	BIOS shutdown test failure.	See "Getting Help" on page 167.

**Table 1-6. LCD Status Messages (continued)**

<b>Code</b>	<b>Text</b>	<b>Causes</b>	<b>Corrective Actions</b>
E201E	POST Mem Test	BIOS POST memory test failure.	See "Troubleshooting System Memory" on page 142. If problem persists, see "Getting Help" on page 167.
E201F	DRAC Config	Dell remote access controller (DRAC) configuration failure.	Check screen for specific error messages. Ensure that DRAC cables and connectors are properly seated. If problem persists, see your DRAC documentation.
E2020	CPU Config	CPU configuration failure.	Check screen for specific error messages.
E2021	Memory Population	Incorrect memory configuration. Memory population order incorrect.	Check screen for specific error messages. See "Troubleshooting System Memory" on page 142.
E2022	POST Fail	General failure after video.	Check screen for specific error messages.
E2110	MBE Crd # DIMM ## & ##	One of the DIMMs in the set implicated by "## & ##" has had a memory multi-bit error (MBE). If no memory card is present, the "Crd #" string is left out of the message.	See "Troubleshooting System Memory" on page 142.

**Table 1-6. LCD Status Messages (continued)**

<b>Code</b>	<b>Text</b>	<b>Causes</b>	<b>Corrective Actions</b>
E2111	SBE Log Disable Crd # DIMM ##	The system BIOS has disabled memory single-bit error (SBE) logging, and will not resume logging further SBEs until the system is rebooted. "##" represents the DIMM implicated by the BIOS. If no memory riser card is present, the "Crd #" string is left out of the message.	See "Troubleshooting System Memory" on page 142.
E2112	Mem Spare Crd # # DIMM ##	The system BIOS has spared the memory because it has determined that the memory had too many errors. "## & ##" represents the DIMM pair implicated by the BIOS. If no memory card is present, the "Crd #" string is left out of the message.	See "Troubleshooting System Memory" on page 142.
E2113	Mem Mirror Crd # DIMM ## & ##	The system BIOS has disabled memory mirroring because it has determined that one half of the mirror has had too many errors. "## & ##" represents the DIMM pair implicated by the BIOS. If no memory card is present, the "Crd #" string is left out of the message.	See "Troubleshooting System Memory" on page 142.
E2118	Fatal NB Mem CRC	One of the connections in the Fully Buffered DIMM (FBD) memory subsystem link on the Northbound side has failed.	See "Troubleshooting System Memory" on page 142.

**Table 1-6. LCD Status Messages (continued)**

<b>Code</b>	<b>Text</b>	<b>Causes</b>	<b>Corrective Actions</b>
E2119	Fatal SB Mem CRC	One of the connections in the FBD memory subsystem link on the Southbound side has failed.	See "Troubleshooting System Memory" on page 142.
I1910	Intrusion	System cover has been removed.	Information only.
I1911	>3 ERRs Chk Log	LCD overflow message. A maximum of three error messages can display sequentially on the LCD. The fourth message displays as the standard overflow message.	Check the SEL for details on the events.
I1912	SEL Full	System Event Log is full of events, and is unable to log any more events.	Clear the log by deleting event entries.

**NOTE:** For the full name of an abbreviation or acronym used in this table, see the "Glossary" on page 169.

## Solving Problems Described by LCD Status Messages

The code and text on the LCD can often specify a very precise fault condition that is easily corrected. For example, if the code E1418 CPU\_1\_Presence appears, you know that a microprocessor is not installed in socket 1.

In contrast, you might be able to determine the problem if multiple related errors occur. For example, if you receive a series of messages indicating multiple voltage faults, you might determine that the problem is a failing power supply.

## Removing LCD Status Messages

For faults associated with sensors, such as temperature, voltage, fans, and so on, the LCD message is automatically removed when that sensor returns to a normal state. For example, if temperature for a component goes out of range,

the LCD displays the fault; when the temperature returns to the acceptable range, the message is removed from the LCD. For other faults, you must take action to remove the message from the display:

- Clear the SEL — You can perform this task remotely, but you will lose the event history for the system.
- Power cycle — Turn off the system and disconnect it from the electrical outlet; wait approximately ten seconds, reconnect the power cable, and restart the system.

Any of these actions will remove fault messages, and return the status indicators and LCD colors to the normal state. Messages will reappear under the following conditions:

- The sensor returns to a normal state but fails again, resulting in a new SEL entry.
- The system is reset and new error events are detected.
- A failure is recorded from another source that maps to the same display entry.

## System Messages

System messages appear on the screen to notify you of a possible problem with the system. Table 1-3 lists the system messages that can occur and the probable cause and corrective action for each message.



**NOTE:** If you receive a system message that is not listed in Table 1-3, check the documentation for the application that is running when the message appears or the operating system's documentation for an explanation of the message and recommended action.



**CAUTION:** Many repairs may only be done by a certified service technician. You should only perform troubleshooting and simple repairs as authorized in your product documentation, or as directed by the online or telephone service and support team. Damage due to servicing that is not authorized by Dell is not covered by your warranty. Read and follow the safety instructions that came with the product.



**Table 1-7. System Messages**

<b>Message</b>	<b>Causes</b>	<b>Corrective Actions</b>
Alert! Redundant memory disabled! Memory configuration does not support redundant memory.	Installed memory modules are not the same type and size; faulty memory module(s).	Ensure that all memory modules are of the same type and size and that they are properly installed. If the problem persists, see "Troubleshooting System Memory" on page 142.
Attempting to update Remote Configuration. Please wait...	Remote Configuration request has been detected and is being processed.	Wait until the process is complete.
BIOS Update Attempt Failed!	Remote BIOS update attempt failed.	Retry the BIOS update. If problem persists, see "Getting Help" on page 167.
Caution! NVRAM_CLR jumper is installed on system board.	NVRAM_CLR jumper is installed. CMOS has been cleared.	Remove NVRAM_CLR jumper. See Figure 6-1 for jumper location.
CPUs with different cache sizes detected!	Microprocessors with different cache sizes are installed.	Ensure that all microprocessors have the same cache size and that they are properly installed. See "Processors" on page 105.
Decreasing available memory	Faulty or improperly installed memory modules.	See "Troubleshooting System Memory" on page 142.

**Table 1-7. System Messages (continued)**

<b>Message</b>	<b>Causes</b>	<b>Corrective Actions</b>
DIMM pairs must be matched in size, speed, and technology. The following DIMM pair is mismatched: DIMM x and DIMM y.	Mismatched or unmatched DIMMs installed; faulty or improperly seated memory module(s).	Ensure that all pairs of memory modules are of the same type and size and that they are properly installed. See "System Memory" on page 100. If the problem persists, see "Troubleshooting System Memory" on page 142.
DIMMs must be populated in sequential order beginning with slot 1. The following DIMM is electrically isolated: DIMM x.	The specified DIMM is inaccessible to the system due to its location. DIMMs must be populated in sequential order, beginning with slot 1.	Populate 2, 4, or 8 DIMMs sequentially beginning with slot 1. See "System Memory" on page 100.
DIMMs should be installed in pairs. Pairs must be matched in size, speed, and technology.	Mismatched or unmatched DIMMs installed; faulty or improperly seated memory module(s). The system will operate in a degraded mode with reduced ECC protection. Only memory installed in channel 0 will be accessible.	Ensure that all pairs of memory modules are of the same type and size and that they are properly installed. See "System Memory" on page 100. If the problem persists, see "Troubleshooting System Memory" on page 142.
Dual-rank DIMM paired with Single-rank DIMM - The following DIMM/rank has been disabled by BIOS: DIMM x Rank y	Mismatched DIMMs installed; faulty memory module(s). The system has detected a dual-rank DIMM paired with a single-rank DIMM. The second rank of the dual-rank DIMM will be disabled.	Ensure that all pairs of memory modules are of the same type and size and that they are properly installed. See "System Memory" on page 100. If the problem persists, see "Troubleshooting System Memory" on page 142.

**Table 1-7. System Messages (continued)**

<b>Message</b>	<b>Causes</b>	<b>Corrective Actions</b>
Diskette drive <i>n</i> seek failure	Incorrect configuration settings in the System Setup program.	Run the System Setup program to correct the settings. See "Using the System Setup Program" on page 45.
	Faulty or improperly installed diskette drive.	Replace the diskette. If the problem persists, see "Troubleshooting an Optical Drive" on page 143.
	Loose tape drive interface cable, or loose power cable.	Reseat tape drive interface cable, or power cable. If the problem persists, see "Troubleshooting an Optical Drive" on page 143.
Diskette read failure	Faulty or improperly inserted diskette or tape drive.	Replace the diskette. See "Troubleshooting an Optical Drive" on page 143.
Diskette subsystem reset failed	Faulty or improperly installed diskette or tape drive.	Replace the diskette or tape. If the problem persists, see "Troubleshooting an Optical Drive" on page 143.
Drive not ready	Diskette missing from or improperly inserted in diskette drive.	Replace the diskette. If the problem persists, see "Troubleshooting an Optical Drive" on page 143.
Error: Incorrect memory configuration. DIMMs must be installed in pairs of matched memory size, speed, and technology.	Mismatched or unmatched DIMMs installed; faulty or improperly seated memory module(s).	Ensure that all pairs of memory modules are of the same type and size and that they are properly installed. See "System Memory" on page 100. If the problem persists, see "Troubleshooting System Memory" on page 142.

**Table 1-7. System Messages (continued)**

<b>Message</b>	<b>Causes</b>	<b>Corrective Actions</b>
Error: Memory failure detected. Memory size reduced. Replace the faulty DIMM as soon as possible.	Faulty or improperly seated memory module(s).	See "Troubleshooting System Memory" on page 142.
!!*** Error: Dell Remote Access Controller initialization failure*** DRAC virtual USB devices may not be available...	Dell Remote Access Controller initialization failure	Ensure that the Dell Remote Access Controller is properly installed. See "DRAC Card and Cables" on page 93.
FBD training error: The following branch has been disabled: Branch x	The specified branch (channel pair) contains DIMMs that are incompatible with each other.	Ensure that only Dell-qualified memory is used. Dell recommends purchasing memory upgrade kits directly from <a href="http://www.dell.com">www.dell.com</a> or your Dell sales agent to ensure compatibility.
Gate A20 failure	Faulty keyboard controller; faulty system board.	See "Getting Help" on page 167.
General failure	The operating system is unable to carry out the command.	This message is usually followed by specific information. Note the information, and take the appropriate action to resolve the problem.
Invalid NVRAM configuration, Resource Re-allocated	System detected and corrected a resource conflict.	No action is required.
Keyboard Controller failure	Faulty keyboard controller; faulty system board	See "Getting Help" on page 167.

**Table 1-7. System Messages (continued)**

<b>Message</b>	<b>Causes</b>	<b>Corrective Actions</b>
Manufacturing mode detected	System is in manufacturing mode.	Reboot to take the system out of manufacturing mode.
MEMBIST failure - The following DIMM/rank has been disabled by BIOS: DIMM x Rank y	Faulty memory module(s).	See "Troubleshooting System Memory" on page 142.
Memory address line failure at <i>address</i> , read <i>value</i> expecting <i>value</i>	Faulty or improperly installed memory modules.	See "Troubleshooting System Memory" on page 142.
Memory double word logic failure at <i>address</i> , read <i>value</i> expecting <i>value</i>		
Memory odd/even logic failure at <i>address</i> , read <i>value</i> expecting <i>value</i>		
Memory write/read failure at <i>address</i> , read <i>value</i> expecting <i>value</i>		
Memory tests terminated by keystroke.	POST memory test terminated by pressing the spacebar.	Information only.

**Table 1-7. System Messages (continued)**

<b>Message</b>	<b>Causes</b>	<b>Corrective Actions</b>
No boot device available	Faulty or missing optical/diskette drive subsystem, hard drive, or hard-drive subsystem, or no boot disk in drive A.	Use a bootable diskette, CD, or hard drive. If the problem persists, see "Troubleshooting an Optical Drive" on page 143, "Troubleshooting an Optical Drive" on page 143, and "Troubleshooting a Hard Drive" on page 146. See "Using the System Setup Program" on page 45 for information on setting the order of boot devices.
No boot sector on hard drive	Incorrect configuration settings in System Setup program, or no operating system on hard drive.	Check the hard-drive configuration settings in the System Setup program. See "Using the System Setup Program" on page 45. If necessary, install the operating system on your hard drive. See your operating system documentation.
No timer tick interrupt	Faulty system board.	See "'Getting Help" on page 167."
Northbound merge error - The following DIMM has been disabled by BIOS: DIMM x	The specified DIMM was unable to establish a successful data link with the memory controller.	See "Troubleshooting System Memory" on page 142.
Not a boot diskette	No operating system on diskette.	Use a bootable diskette.

**Table 1-7. System Messages (continued)**

<b>Message</b>	<b>Causes</b>	<b>Corrective Actions</b>
PCIe Degraded Link Width Error: Embedded Bus# <i>nn</i> /Dev# <i>nn</i> /Func <i>n</i> Expected Link Width is <i>n</i> Actual Link Width is <i>n</i>	Faulty or improperly installed PCIe card in the specified slot.	Reseat the PCIe card in the specified slot number. See "Expansion Cards" on page 88. If the problem persists, see "Getting Help" on page 167.
PCIe Degraded Link Width Error: Slot <i>n</i> Expected Link Width is <i>n</i> Actual Link Width is <i>n</i>	Faulty or improperly installed PCIe card in the specified slot.	Reseat the PCIe card in the specified slot number. See "Expansion Cards" on page 88. If the problem persists, see "Getting Help" on page 167.
PCIe Training Error: Embedded Bus# <i>nn</i> /Dev# <i>nn</i> /Func <i>n</i> PCIe Training Error: Slot <i>n</i>	Faulty or improperly installed PCIe card in the specified slot.	Reseat the PCIe card in the specified slot number. See "Expansion Cards" on page 88. If the problem persists, see "Getting Help" on page 167.
PCI BIOS failed to install	PCI device BIOS (Option ROM) checksum failure is detected during shadowing. Loose cables to expansion card(s); faulty or improperly installed expansion card(s).	Reseat the expansion card(s). Ensure that all appropriate cables are securely connected to the expansion card(s). If the problem persists, see "Troubleshooting Expansion Cards" on page 149.
Plug & Play Configuration Error	Error encountered in initializing PCI device; faulty system board.	Install the NVRAM_CLR jumper and reboot the system. See Figure 6-1 for jumper location. If the problem persists, see "Troubleshooting Expansion Cards" on page 149.

**Table 1-7. System Messages (continued)**

<b>Message</b>	<b>Causes</b>	<b>Corrective Actions</b>
Read fault Requested sector not found	The operating system cannot read from the diskette or hard drive, the system could not find a particular sector on the disk, or the requested sector is defective.	Replace the diskette. Ensure that the diskette and hard drive cables are properly connected. See "Troubleshooting a USB Device" on page 134, or "Troubleshooting a Hard Drive" on page 146 for the appropriate drive(s) installed in your system.
Remote configuration update attempt failed	System unable to process Remote Configuration request	Retry Remote Configuration.
ROM bad checksum = address	Expansion card improperly installed or faulty.	Reseat the expansion card(s). Ensure that all appropriate cables are securely connected to the expansion card(s). If the problem persists, see "Troubleshooting Expansion Cards" on page 149.
Sector not found Seek error Seek operation failed	Faulty diskette or hard drive.	See "Troubleshooting an Optical Drive" on page 143, "Troubleshooting a USB Device" on page 134, or "Troubleshooting a Hard Drive" on page 146 for the appropriate drive(s) installed in your system.
Shutdown failure	Shutdown test failure.	See "Troubleshooting System Memory" on page 142.



**Table 1-7. System Messages (continued)**

<b>Message</b>	<b>Causes</b>	<b>Corrective Actions</b>
The amount of system memory has changed	Memory has been added or removed or a memory module may be faulty.	If memory has been added or removed, this message is informative and can be ignored. If memory has not been added or removed, check the SEL to determine if single-bit or multi-bit errors were detected and replace the faulty memory module. See "Troubleshooting System Memory" on page 142.
Time-of-day clock stopped	Faulty battery or faulty chip.	See "Troubleshooting the System Battery" on page 138.
The following DIMM pair is not compatible with the memory controller: DIMM x and DIMM y	The specified DIMM(s) are incompatible with the system.	Ensure that only Dell-qualified memory is used. Dell recommends purchasing memory upgrade kits directly from <a href="http://www.dell.com">www.dell.com</a> or your Dell sales agent to ensure compatibility.
The following DIMMs are not compatible: DIMM x and DIMM y	The specified DIMM(s) are incompatible with the system.	Ensure that only ECC FBD1 memory is used. Dell recommends purchasing memory upgrade kits directly from <a href="http://www.dell.com">www.dell.com</a> or your Dell sales agent to ensure compatibility.
Time-of-day not set - please run SETUP program	Incorrect Time or Date settings; faulty system battery.	Check the Time and Date settings. See "Using the System Setup Program" on page 45. If the problem persists, replace the system battery. See "System Battery" on page 110.

**Table 1-7. System Messages (continued)**

<b>Message</b>	<b>Causes</b>	<b>Corrective Actions</b>
Timer chip counter 2 failed	Faulty system board.	See "Getting Help" on page 167.
Unsupported CPU combination Unsupported CPU stepping detected	Microprocessor(s) is not supported by the system.	Install a supported microprocessor or microprocessor combination. See "Processors" on page 105.
Utility partition not available	The <F10> key was pressed during POST, but no utility partition exists on the boot hard drive.	Create a utility partition on the boot hard drive. See the CDs that came with your system.
Warning! No micro code update loaded for processor 0	Micro code update failed.	Update the BIOS firmware. See "Getting Help" on page 167.
Warning: Embedded RAID firmware is not present.	Embedded RAID firmware does not respond.	See the RAID controller documentation for information about installing or updating the RAID firmware.
Warning: Embedded RAID error.	Embedded RAID firmware responds with an error.	See "Troubleshooting a SAS Controller Daughter Card" on page 147. See the RAID controller documentation for information about installing or updating the RAID firmware.

**Table 1-7. System Messages (continued)**

Message	Causes	Corrective Actions
Warning: The current memory configuration is not optimal. Dell recommends a population of 2, 4, or 8 DIMMs. DIMMs should be populated sequentially starting in slot 1.	System has detected a legal but non-optimal population of DIMMs (for example, 1 DIMM, 6 DIMMs, 4 DIMMs in slots 1, 2, 5, and 6, etc.). The system will run with all memory accessible but will experience sub-optimal performance.	Populate 2, 4, or 8 DIMMs sequentially beginning with slot 1. See "System Memory" on page 100.
Write fault Write fault on selected drive	Faulty diskette, optical/diskette drive assembly, hard drive, or hard-drive subsystem.	See "Troubleshooting an Optical Drive" on page 143, "Troubleshooting an Optical Drive" on page 143, and "Troubleshooting a Hard Drive" on page 146.

**NOTE:** For the full name of an abbreviation or acronym used in this table, see the "Glossary" on page 169.

## Warning Messages

A warning message alerts you to a possible problem and prompts you to respond before the system continues a task. For example, before you format a diskette, a message will warn you that you may lose all data on the diskette. Warning messages usually interrupt the task and require you to respond by typing *y* (yes) or *n* (no).



**NOTE:** Warning messages are generated by either the application or the operating system. For more information, see the documentation that accompanied the operating system or application.

## **Diagnostics Messages**

When you run system diagnostics, an error message may result. Diagnostic error messages are not covered in this section. Record the message on a copy of the Diagnostics Checklist in "Getting Help" on page 167, and then follow the instructions in that section for obtaining technical assistance.

## **Alert Messages**

Systems management software generates alert messages for your system. Alert messages include information, status, warning, and failure messages for drive, temperature, fan, and power conditions. For more information, see the systems management software documentation.

# Using the System Setup Program

After you set up your system, run the System Setup program to familiarize yourself with your system configuration and optional settings. Record the information for future reference.

You can use the System Setup program to:

- Change the system configuration stored in NVRAM after you add, change, or remove hardware
- Set or change user-selectable options—for example, the time or date
- Enable or disable integrated devices
- Correct discrepancies between the installed hardware and configuration settings

## Entering the System Setup Program

- 1 Turn on or restart your system.
- 2 Press <F2> immediately after you see the following message:

<F2> = System Setup

If your operating system begins to load before you press <F2>, allow the system to finish booting, and then restart your system and try again.

 **NOTE:** To ensure an orderly system shutdown, see the documentation that accompanied your operating system.

## Responding to Error Messages

You can enter the System Setup program by responding to certain error messages. If an error message appears while the system is booting, make a note of the message. Before entering the System Setup program, see "System Messages" on page 32 for an explanation of the message and suggestions for correcting errors.

 **NOTE:** After installing a memory upgrade, it is normal for your system to send a message the first time you start your system.

## Using the System Setup Program

Table 2-1 lists the keys that you use to view or change information on the System Setup program screens and to exit the program.

**Table 2-1. System Setup Program Navigation Keys**

Keys	Action
Up arrow or <Shift><Tab>	Moves to the previous field.
Down arrow or <Tab>	Moves to the next field.
Spacebar, <+>, <->, left and right arrows	Cycles through the settings in a field. In many fields, you can also type the appropriate value.
<Esc>	Exits the System Setup program and restarts the system if any changes were made.
<F1>	Displays the System Setup program's help file.



**NOTE:** For most of the options, any changes that you make are recorded but do not take effect until you restart the system.

## System Setup Options

### Main Screen

When you enter the System Setup program, the main System Setup program screen appears (see Figure 2-1).

**Figure 2-1. Main System Setup Program Screen**

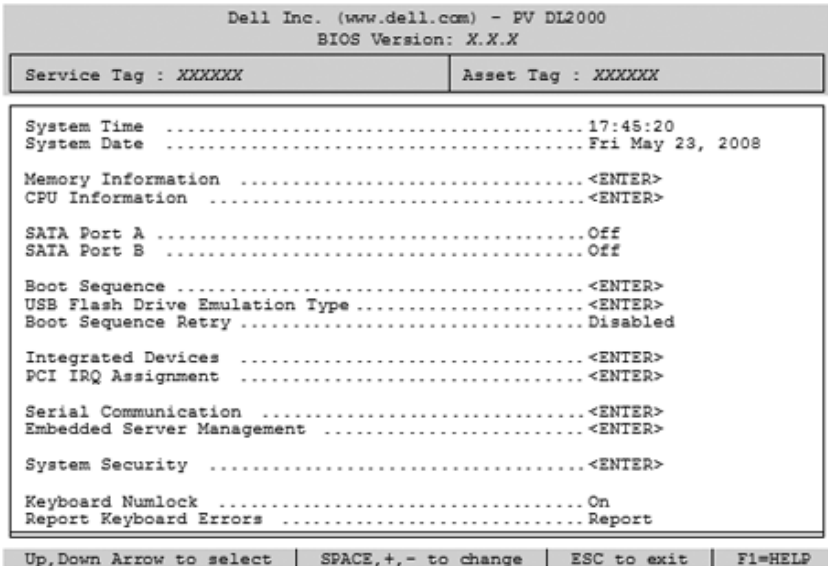



Table 2-2 lists the options and descriptions for the information fields that appear on the main System Setup program screen.

-  **NOTE:** The options for the System Setup program change based on the system configuration.
-  **NOTE:** The System Setup program defaults are listed under their respective options, where applicable.

**Table 2-2. System Setup Program Options**

Option	Description
System Time	Resets the time on the system's internal clock.
System Date	Resets the date on the system's internal calendar.
Memory Information	Displays information related to installed system, video, and redundant memory, including size, type, and speed.

**Table 2-2. System Setup Program Options (continued)**

<b>Option</b>	<b>Description</b>
CPU Information	Displays information related to microprocessors (speed, cache size, and so on). Enable or disable Hyper-Threading technology by changing the setting of the <b>Logical Processor</b> option. See Table 2-4.
SATA Port X	Displays type and capacity of SATA drive attached to Port X.
Boot Sequence	Determines the order in which the system searches for boot devices during system startup. Available options can include the diskette drive, CD drive, hard drives, and network. If you have installed a DRAC, additional options such as virtual floppy and virtual CD-ROM may be present.  <b>NOTE:</b> System boot is not supported from an external device attached to a SAS or SCSI adapter. See <a href="http://support.dell.com">support.dell.com</a> for the latest support information about booting from external devices
USB Flash Drive Type (Auto default)	Determines the emulation type for a USB flash drive. <b>Hard disk</b> allows the USB flash drive to act as a hard drive. <b>Floppy</b> allows the USB flash drive to act as a removal diskette drive. <b>Auto</b> automatically chooses an emulation type.
Boot Sequence Retry (Disabled default)	Enables or disables the Boot Sequence Retry feature. <b>Enabled</b> allows the system to re-attempt the Boot Sequence after a 30-second timeout if the last boot attempt failed.
Integrated Devices	See Table 2-5.
PCI IRQ Assignment	Displays a screen to change the IRQ assigned to each of the integrated devices on the PCI bus, and any installed expansion cards that require an IRQ.
Serial Communication	Displays a screen to configure serial communication, external serial connector, fail-safe baud rate, remote terminal type, and redirection after boot.
Embedded Server Management	Displays a screen to configure the front-panel LCD options and to set a user-defined LCD string.
System Security	Displays a screen to configure the system password and setup password features. See Table 2-7. For further information, see "Using the System Password" on page 56 and "Using the Setup Password" on page 59.



**Table 2-2. System Setup Program Options (continued)**

<b>Option</b>	<b>Description</b>
Keyboard NumLock (On default)	Determines whether your system starts up with the NumLock mode activated on 101- or 102-key keyboards (does not apply to 84-key keyboards).
Report Keyboard Errors (Report default)	Enables or disables reporting of keyboard errors during the POST. Select <b>Report</b> for host systems that have keyboards attached. Select <b>Do Not Report</b> to suppress all error messages relating to the keyboard or keyboard controller during POST. This setting does not affect the operation of the keyboard itself if a keyboard is attached to the system.
Asset Tag	Displays the customer-programmable asset tag number for the system if an asset tag number has been assigned.

## Memory Information Screen

Table 2-3 lists the descriptions for the information fields that appear on the **Memory Information** screen.

**Table 2-3. Memory Information Screen**

<b>Option</b>	<b>Description</b>
System Memory Size	Displays the amount of system memory.
System Memory Type	Displays the type of system memory.
System Memory Speed	Displays the system memory speed.
Video Memory	Displays the amount of video memory.
System Memory Testing	Specifies whether system memory tests are run at system boot. Options are <b>Enabled</b> and <b>Disabled</b> .
Redundant Memory (Disabled default)	Enables or disables the redundant memory feature. When set to <b>Spare Mode</b> , the first rank of memory on each DIMM is reserved for memory sparing. See "Memory Sparing Support" on page 101. Redundant memory feature is disabled if the Node Interleaving field is enabled.

**Table 2-3. Memory Information Screen (continued)**

<b>Option</b>	<b>Description</b>
Snoop Filter (Disabled default)	Enables or disables the snoop filter option.
Low Power Mode (Disabled default)	Enables or disables the low power mode of the memory. When set to <b>Disabled</b> , the memory runs at full speed. When set to <b>Enabled</b> , the memory runs at a reduced speed to conserve energy. <b>NOTE:</b> On some systems and memory combinations, changing the value from <b>Enabled</b> to <b>Disabled</b> requires a cold reboot.

### **CPU Information Screen**

Table 2-4 lists the options and descriptions for the information fields that appear on the **CPU Information** screen.

**Table 2-4. CPU Information Screen**

<b>Option</b>	<b>Description</b>
Bus Speed	Displays the bus speed of the processors.
Logical Processor (Enabled default)	Displays when the processors support HyperThreading. <b>Enabled</b> permits all logical processors to be used by the operating system. Only the first logical processor of each processor installed in the system is used by the operating system if <b>Disabled</b> is selected.
Adjacent Cache Line Prefetch (Enabled default)	Enables or disables optimal use of sequential memory access. Disable this option for applications that require high use of random memory access.
Virtualization Technology (Disabled default)	Displays when the processor(s) support Virtualization Technology. <b>Enabled</b> permits virtualization software to utilize Virtualization Technology functions incorporated in the processor design. This feature can only be used by software that supports Virtualization Technology.
Hardware Prefetcher (Enabled default)	Enables or disables the hardware prefetcher.

**Table 2-4. CPU Information Screen (continued)**

Option	Description
Demand-Based Power Management (Enabled default)	Enables or disables demand-based power management. When enabled, the CPU Performance State tables will be reported to the operating system; when disabled, the CPU Performance State tables will not be reported to the operating system. If any of the CPUs do not support demand-based power management, the field will become read-only, and automatically set to <b>Disabled</b> .
Processor X ID	Displays the family and model number of each processor. A submenu displays processor core speed, amount of level 2 cache, and number of cores.

## Integrated Devices Screen

Table 2-5 lists the options and descriptions for the information fields that appear on the **Integrated Devices** screen.

**Table 2-5. Integrated Devices Screen Options**

Option	Description
Integrated SAS Controller (Enabled default)	Enables or disables the integrated SAS controller.
Embedded SATA (Off default)	Allows the integrated SATA controller to be set to <b>Off</b> or <b>ATA Mode</b> .
IDE CD-ROM Controller (Auto default)	Enables the integrated IDE controller. When set to <b>Auto</b> , each channel of the integrated IDE controller is enabled if IDE devices are attached to the channel and the external IDE controller is not detected.  <b>NOTE:</b> This CD-ROM option will not appear on this menu screen if your system does not include this optional device.
User Accessible USB Ports (All Ports On default)	Enables or disables the system's user accessible USB ports. Options are <b>All Ports On</b> , <b>Only Back Ports On</b> , and <b>All Ports Off</b> .
Internal USB Port (On default)	Enables or disables the system's internal USB port. This option is active only when User Accessible USB ports is set to <b>All Ports On</b> .

**Table 2-5. Integrated Devices Screen Options (continued)**

<b>Option</b>	<b>Description</b>
Embedded Gb NIC1 (Enabled with PXE default)	Enables or disables the system's integrated NIC. Options are <b>Enabled without PXE</b> , <b>Enabled with PXE</b> , and <b>Disabled</b> . PXE support allows the system to boot from the network. Changes take effect after the system reboots.
MAC Address	Displays the MAC address for the integrated 10/100/1000 NIC. This field does not have user-selectable settings.
TOE Capability	Displays the TCP/IP offload engine (TOE) feature status of the onboard NIC.
Embedded Gb NIC2 (Enabled with PXE default)	Enables or disables the system's integrated NIC. Options are <b>Enabled without PXE</b> , <b>Enabled with PXE</b> , and <b>Disabled</b> . PXE support allows the system to boot from the network. Changes take effect after the system reboots.
MAC Address	Displays the MAC address for the integrated 10/100/1000 NIC. This field does not have user-selectable settings.
TOE Capability	Displays the TCP/IP offload engine (TOE) feature status of the onboard NIC.
Diskette Controller (Auto default)	Enables or disables the system's diskette drive controller. When <b>Auto</b> is selected, the system turns off the controller when necessary to accommodate a controller card installed in an expansion slot. You can also configure the drive as <b>Read-Only</b> , or <b>Off</b> . When using the <b>Read-Only</b> setting, the drive cannot be used to write to a disk.
OS Watchdog Timer (Disabled default)	<b>NOTE:</b> This feature is usable only with operating systems that support WDAT implementations of the Advanced Configuration and Power Interface (ACPI) 3.0b specification.  Sets a timer that monitors the operating system for activity and aids in recovery if the system stops responding. When this field is set to <b>Enabled</b> , the operating system is allowed to initialize the timer. When set to <b>Disabled</b> , the timer is not initialized.
I/OAT DMA Engine (Disable default)	Enables or disables the I/O Acceleration Technology (I/OAT) option. This feature should be enabled only if the hardware and software support I/OAT.
System Interrupts Assignment (Standard default)	Controls the interrupt assignment of PCI devices in the system. <b>Distributed</b> swizzles the interrupt routing to minimize IRQ sharing.

## Serial Communication Screen

Table 2-6 lists the options and descriptions for the information fields that appear on the **Serial Communication** screen.

**Table 2-6. Serial Communication Screen Options**

Option	Description
Serial Communication (Off default)	Options are <b>On with Console Redirection</b> via COM2, and <b>Off</b> .
Failsafe Baud Rate (57600 default)	Displays the failsafe baud rate used for console redirection when the baud rate cannot be negotiated automatically with the remote terminal. This rate should not be adjusted.
Remote Terminal Type (VT 100/VT 220 default)	Select either <b>VT 100/VT 220</b> or <b>ANSI</b> .
Redirection After Boot (Enabled default)	Enables or disables BIOS console redirection after your system boots to the operating system.

## System Security Screen

Table 2-7 lists the options and descriptions for the information fields that appear on the **System Security** screen.



**Table 2-7. System Security Screen Options**

Option	Description
System Password	Displays the current status of your system's password security feature and allows you to assign and verify a new system password. <b>NOTE:</b> See "Using the System Password" on page 56 for instructions on assigning a system password and using or changing an existing system password.
Setup Password	Restricts access to the System Setup program in the same way that you restrict access to your system using the system password feature. <b>NOTE:</b> See "Using the Setup Password" on page 59 for instructions on assigning a setup password and using or changing an existing setup password.

**Table 2-7. System Security Screen Options (continued)**

Option	Description
Password Status	<p>Setting the <b>Setup Password</b> option to <b>Enabled</b> prevents the system password from being changed or disabled at system start-up.</p> <p>To <i>lock</i> the system password, assign a setup password in the <b>Setup Password</b> option and then change the <b>Password Status</b> option to <b>Locked</b>. In this state, you cannot change the system password using the <b>System Password</b> option and cannot be disabled at system start-up by pressing &lt;Ctrl&gt;&lt;Enter&gt;.</p> <p>To <i>unlock</i> the system password, enter the setup password in the <b>Setup Password</b> field and then change the <b>Password Status</b> option to <b>Unlocked</b>. In this state, you can disable the system password at system start-up by pressing &lt;Ctrl&gt;&lt;Enter&gt; and then change the password using the <b>System Password</b> option.</p>
TPM Security (Off default)	<p>Sets the reporting of the Trusted Platform Module (TPM) in the system.</p> <p>When set to <b>Off</b> (default), presence of the TPM is not reported to the operating system.</p> <p>When set to <b>On</b> with <b>Pre-boot Measurements</b>, the system reports the TPM to the operating system and stores the pre-boot measurements (compliant with Trusted Computing Group standards) to the TPM during POST.</p> <p>When set to <b>On without Pre-boot Measurements</b>, the system reports the TPM to the operating system and bypasses pre-boot measurements.</p>
TPM Activation	<p>Changes the operational state of the TPM.</p> <p>When set to <b>Activate</b>, the TPM is enabled and activated at default settings.</p> <p>When set to <b>Deactivate</b>, the TPM is disabled and deactivated.</p> <p>The <b>No Change</b> state initiates no action. The operational state of the TPM remains unchanged (all user settings for the TPM are preserved).</p> <p><b>NOTE:</b> This field is read-only when <b>TPM Security</b> is set to <b>Off</b>.</p>

**Table 2-7. System Security Screen Options (continued)**

Option	Description
TPM Clear (No default)	<p> <b>NOTICE:</b> Clearing the TPM will cause loss of all encryption keys in the TPM. This will prevent booting to the operating system and result in loss of data if the encryption keys cannot be restored. Be sure to back up the TPM keys prior to enabling this option.</p> <p>When set to <b>Yes</b>, all the contents of the TPM are cleared.</p> <p><b>NOTE:</b> This field is read-only when <b>TPM Security</b> is set to <b>Off</b>.</p>
Power Button ( <b>Enabled</b> default)	<p>Turns system's power off and on.</p> <ul style="list-style-type: none"><li>• If you turn off the system using the power button and the system is running an ACPI-compliant operating system, the system can perform an orderly shutdown before power is turned off.</li><li>• If the system is not running an ACPI-compliant operating system, power is turned off immediately after the power button is pressed.</li></ul> <p>The button is enabled in the System Setup program. When disabled, the button can only turn on system power.</p> <p><b>NOTE:</b> You can still turn on the system by using the power button, even if the <b>Power Button</b> option is set to <b>Disabled</b>.</p>
NMI Button ( <b>Disabled</b> default)	<p> <b>NOTICE:</b> Use the NMI button only if directed to do so by qualified support personnel or by the operating system's documentation. Pressing this button halts the operating system and displays a diagnostic screen.</p> <p>Sets the NMI feature <b>On</b> or <b>Off</b>.</p>
AC Power Recovery ( <b>Last</b> default)	<p>Determines how the system reacts when power is restored to the system. If system is set to <b>Last</b>, the system returns to the last power state. <b>On</b> turns on the system after power is restored. When set to <b>Off</b>, the system remains off after power is restored.</p>

## Exit Screen

After you press <Esc> to exit the System Setup program, the **Exit** screen displays the following options:

- Save Changes and Exit
- Discard Changes and Exit
- Return to Setup

## System and Setup Password Features

 **NOTICE:** The password features provide a basic level of security for the data on your system. If your data requires more security, use additional forms of protection, such as data encryption programs.

 **NOTICE:** Anyone can access the data stored on your system if you leave the system running and unattended without having a system password assigned or if you leave your system unlocked so that someone can disable the password by changing a jumper setting.

Your system is shipped to you without the system password feature enabled. If system security is a concern, operate your system only with system password protection.

To change or delete an existing password, you must know the password (see "Deleting or Changing an Existing System Password" on page 59). If you forget your password, you cannot operate your system or change settings in the System Setup program until a trained service technician changes the password jumper setting to disable the passwords, and erases the existing passwords. This procedure is described in "Disabling a Forgotten Password" on page 164.

## Using the System Password

After a system password is assigned, only those who know the password have full use of the system. When the **System Password** option is set to **Enabled**, the system prompts you for the system password after the system starts.



## Assigning a System Password

Before you assign a system password, enter the System Setup program and check the **System Password** option.

When a system password is assigned, the setting shown for the **System Password** option is **Enabled**. If the setting shown for the **Password Status** is **Unlocked**, you can change the system password. If the **Password Status** option is **Locked**, you cannot change the system password. When the system password feature is disabled by a jumper setting, the system password is **Disabled**, and you cannot change or enter a new system password.

When a system password is not assigned and the password jumper on the system board is in the enabled (default) position, the setting shown for the **System Password** option is **Not Enabled** and the **Password Status** field is **Unlocked**. To assign a system password:

- 1 Verify that the **Password Status** option is set to **Unlocked**.
- 2 Highlight the **System Password** option and press <Enter>.
- 3 Type your new system password.

You can use up to 32 characters in your password.

As you press each character key (or the spacebar for a blank space), a placeholder appears in the field.

The password assignment is not case-sensitive. However, certain key combinations are not valid. If you enter one of these combinations, the system beeps. To erase a character when entering your password, press <Backspace> or the left-arrow key.

 **NOTE:** To escape from the field without assigning a system password, press <Enter> to move to another field, or press <Esc> at any time prior to completing step 5.

- 4 Press <Enter>.
- 5 To confirm your password, type it a second time and press <Enter>.

The setting shown for the **System Password** changes to **Enabled**. Exit the System Setup program and begin using your system.

- 6 Either reboot your system now for your password protection to take effect or continue working.

 **NOTE:** Password protection does not take effect until you reboot the system.

## Using Your System Password to Secure Your System



**NOTE:** If you have assigned a setup password (see "Using the Setup Password" on page 59), the system accepts your setup password as an alternate system password.

When the **Password Status** option is set to **Unlocked**, you have the option to leave the password security enabled or to disable the password security.

To leave the password security enabled:

- 1 Turn on or reboot your system by pressing <Ctrl> <Alt> <Del>.
- 2 Type your password and press <Enter>.

To disable the password security:

- 1 Turn on or reboot your system by pressing <Ctrl> <Alt> <Del>.
- 2 Type your password and press <Ctrl> <Enter>.

When the **Password Status** option is set to **Locked** whenever you turn on your system or reboot your system by pressing <Ctrl> <Alt> <Del>, type your password and press <Enter> at the prompt.

After you type the correct system password and press <Enter>, your system operates as usual.

If an incorrect system password is entered, the system displays a message and prompts you to re-enter your password. You have three attempts to enter the correct password. After the third unsuccessful attempt, the system displays an error message showing the number of unsuccessful attempts and that the system has halted and will shut down. This message can alert you to an unauthorized person attempting to use your system.

Even after you shut down and restart the system, the error message continues to be displayed until the correct password is entered.



**NOTE:** You can use the **Password Status** option in conjunction with the **System Password** and **Setup Password** options to further protect your system from unauthorized changes.

## Deleting or Changing an Existing System Password

- 1 When prompted, press <Ctrl><Enter> to disable the existing system password.

If you are asked to enter your setup password, contact your network administrator.

- 2 Enter the System Setup program by pressing <F2> during POST.
- 3 Select the **System Security** screen field to verify that the **Password Status** option is set to **Unlocked**.
- 4 When prompted, type the system password.
- 5 Confirm that **Not Enabled** is displayed for the **System Password** option.

If **Not Enabled** is displayed for the **System Password** option, the system password has been deleted. If **Enabled** is displayed for the **System Password** option, press the <Alt><b> key combination to restart the system, and then repeat steps 2 through 5.

## Using the Setup Password

### Assigning a Setup Password

You can assign (or change) a setup password only when the **Setup Password** option is set to **Not Enabled**. To assign a setup password, highlight the **Setup Password** option and press the <+> or <-> key. The system prompts you to enter and verify the password. If a character is illegal for password use, the system beeps.



**NOTE:** The setup password can be the same as the system password. If the two passwords are different, the setup password can be used as an alternate system password. However, the system password cannot be used in place of the setup password.

You can use up to 32 characters in your password.

As you press each character key (or the spacebar for a blank space), a placeholder appears in the field.

The password assignment is not case-sensitive. However, certain key combinations are not valid. If you enter one of these combinations, the system beeps. To erase a character when entering your password, press <Backspace> or the left-arrow key.

After you verify the password, the **Setup Password** setting changes to **Enabled**. The next time you enter the System Setup program, the system prompts you for the setup password.

A change to the **Setup Password** option becomes effective immediately (restarting the system is not required).

### **Operating With a Setup Password Enabled**

If **Setup Password** is set to **Enabled**, you must enter the correct setup password before you can modify most of the System Setup options. When you start the System Setup program, the program prompts you to enter a password.

If you do not enter the correct password in three attempts, the system lets you view, but not modify, the System Setup screens—with the following exception: If **System Password** is not set to **Enabled** and is not locked through the **Password Status** option, you can assign a system password (however, you cannot disable or change an existing system password).



**NOTE:** You can use the **Password Status** option in conjunction with the **Setup Password** option to protect the system password from unauthorized changes.

### **Deleting or Changing an Existing Setup Password**

- 1** Enter the System Setup program and select the **System Security** option.
- 2** Highlight the **Setup Password** option, press <Enter> to access the setup password window, and press <Enter> twice to clear the existing setup password.

The setting changes to **Not Enabled**.

- 3** If you want to assign a new setup password, perform the steps in "Assigning a Setup Password" on page 59.

## **Disabling a Forgotten Password**

See "Disabling a Forgotten Password" on page 164.

# Baseboard Management Controller Configuration

The Baseboard Management Controller (BMC) enables configuring, monitoring, and recovery of systems remotely. BMC provides the following features:

- Uses the system's integrated NIC
- Fault logging and SNMP alerting
- Access to system event log and sensor status
- Control of system functions including power on and off
- Support is independent of the system's power or operating state
- Provides text console redirection for system setup, text-based utilities, and operating system consoles



**NOTE:** To remotely access the BMC through the integrated NIC, you must connect the network connection to integrated NIC1.

For additional information on using BMC, see the documentation for the BMC and systems management applications.

## Entering the BMC Setup Module

- 1 Turn on or restart your system.
- 2 Press <Ctrl-E> when prompted after POST.

If your operating system begins to load before you press <Ctrl-E>, allow the system to finish booting, and then restart your system and try again.

## BMC Setup Module Options

For information about the BMC Setup Module options and how to configure the emergency management port (EMP), see the *BMC User's Guide*.



# Installing System Components

This section describes how to install the following system components:

- Hard drives
- Power supplies
- System fans
- Cooling shroud
- Fan brackets
- Cable routing
- SAS controller daughter card
- Expansion cards
- Expansion card cage
- DRAC card and cables
- Optical drive and cables
- System memory
- Processors
- System battery
- Expansion-card riser boards
- Sideplane board
- SAS Backplane board
- Control panel assembly
- System board

## Recommended Tools

You may need the following items to perform the procedures in this section:

- Key to the system keylock
- #1 and #2 Phillips screwdrivers
- T-10 Torx driver
- Wrist grounding strap

# Inside the System

**⚠ CAUTION:** Many repairs may only be done by a certified service technician. You should only perform troubleshooting and simple repairs as authorized in your product documentation, or as directed by the online or telephone service and support team. Damage due to servicing that is not authorized by Dell is not covered by your warranty. Read and follow the safety instructions that came with the product.

In Figure 3-1, the bezel and system cover are removed to provide an interior view of the system.

**Figure 3-1. Inside the System**

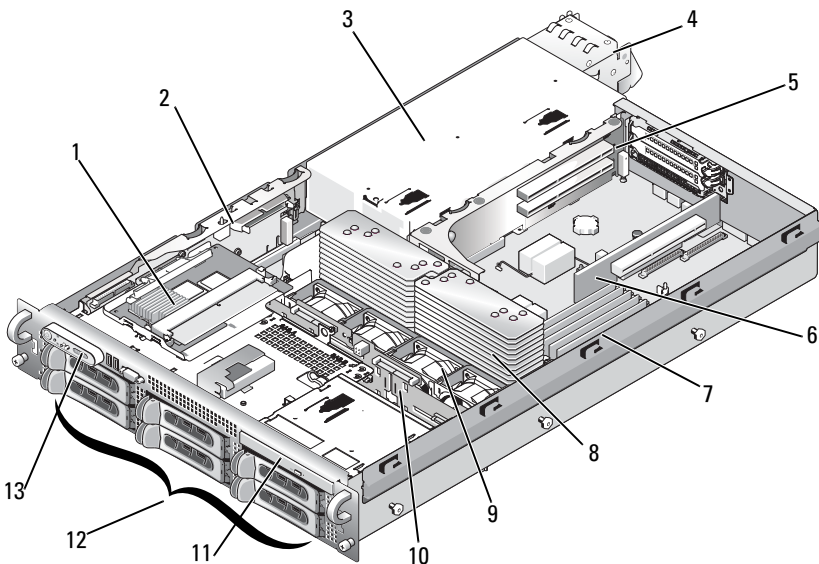



- |                                |   |
|--------------------------------|---|
| 1 SAS controller daughter card | 2 sideplane   |
| 3 power supply bay             | 4 power supplies (2)                                      |
| 5 left riser                   | 6 central riser   |
| 7 memory modules (8)           | 8 heatsinks and microprocessors (2)                       |
| 9 hot-pluggable fans (4)       | 10 SAS backplane  |
| 11 slimline optical drive      | 12 SATA hard drives (up to 4, depending on configuration) |
- 13 control panel

The system board holds the system's control circuitry and other electronic components. Several hardware options, such as the microprocessors and memory, are installed directly on the system board. The expansion-card cage containing the left riser accommodates up to two full-length PCIe expansion cards, while the central riser accommodates one half-length PCIe expansion card.

The system provides space for an optical drive. The optical drive connects to the controllers on the system board through the sideplane board. For more information, see "Optical Drive and Cable" on page 96.

The hard-drive bays provide space for up to four 3.5-inch SATA hard drives. The hard drives connect to a SAS controller card through the SAS backplane board. For more information, see "Hard Drives" on page 68 and "SAS Controller Daughter Card" on page 85.

During an installation or troubleshooting procedure, you may be required to change a jumper setting. For more information, see "System Board Jumpers" on page 157.

## Front Bezel

A lock on the bezel restricts access to the power button, optical drive, and hard drive(s). A control panel LCD located on the front panel and accessible through the front bezel displays the system's status.

### Removing the Front Bezel

- 1 Using the system key, unlock the bezel.
- 2 Press the tab at the left end of the bezel.

- 3 Rotate the left end of the bezel away from the system to release the right end of the bezel.
- 4 Pull the bezel away from the system. See Figure 3-2.

**Figure 3-2. Removing the Front Bezel**

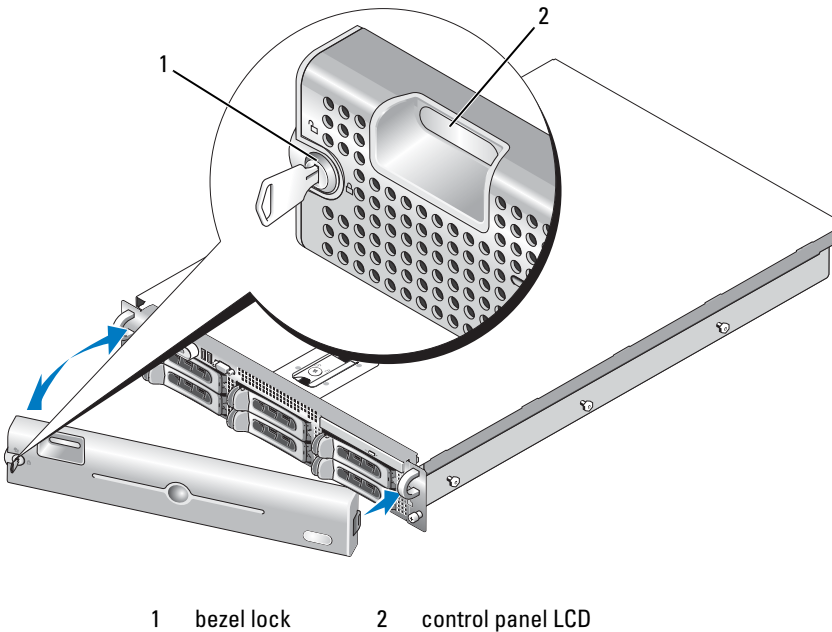

## Replacing the Front Bezel

To replace the front bezel, perform the above steps in reverse.

## Opening and Closing the System

**⚠ CAUTION:** Many repairs may only be done by a certified service technician. You should only perform troubleshooting and simple repairs as authorized in your product documentation, or as directed by the online or telephone service and support team. Damage due to servicing that is not authorized by Dell is not covered by your warranty. Read and follow the safety instructions that came with the product.

## Opening the System

To upgrade or troubleshoot the system, remove the system cover to gain access to internal components.

- 1** Unless you are installing a hot-plug component such as a cooling fan or power supply, turn off the system and attached peripherals, and disconnect the system from the electrical outlet and peripherals.
- 2** To remove the system cover, turn the latch release lock counter-clockwise to the unlocked position. See Figure 3-3.
- 3** Lift up on the latch on top of the system. See Figure 3-3.
- 4** Grasp the cover on both sides and carefully lift the cover away from the system.

## Closing the System

- 1** Lift up the latch on the cover.
- 2** Place the cover on top of the system and offset the cover slightly back so that it clears the chassis J hooks and lays flush on the system chassis. See Figure 3-3.
- 3** Push down the latch to lever the cover into the closed position.
- 4** Rotate the latch release lock in a clockwise direction to secure the cover.

**Figure 3-3. Removing the Cover**

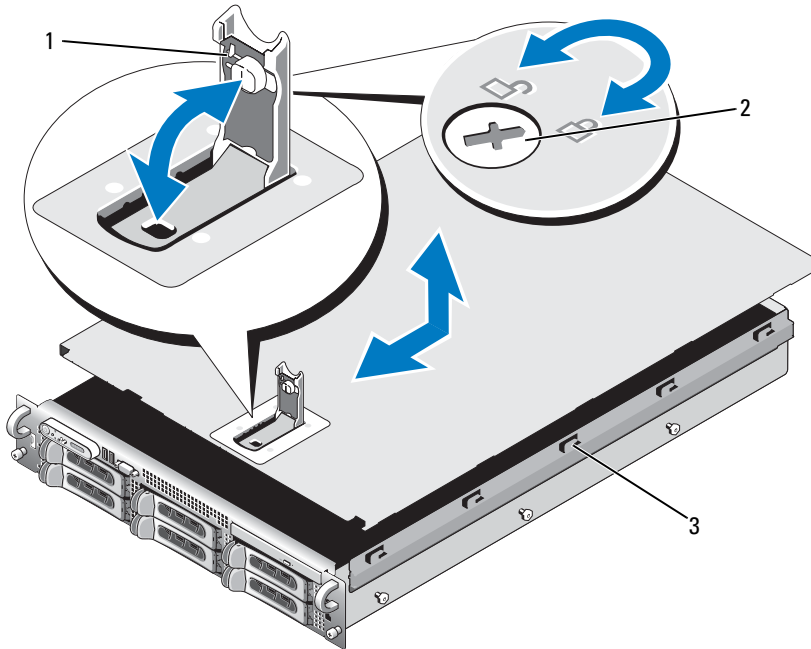

- 1 latch
- 2 latch release lock
- 3 alignment J hooks

## Hard Drives

This subsection describes how to install and configure SATA hard drives in the system's internal hard-drive bays. Your system features up to four SATA 3.5-inch hard drives. All drives connect to the system board through the SAS backplane board. See "SAS Backplane Board Connectors" on page 161 for information on these backplane options.

**NOTE:** Depending on the hard drive configuration you ordered, your hard drive(s) may come with a drive interposer that allows your SATA drive to attach to the SAS connector on the backplane.

## Before You Begin

Hard drives are supplied in special hot-pluggable drive carriers that fit in the hard-drive bays. Depending on your configuration, you received one of the following two drive carrier types:

- SATA drive carrier — Usable only with a SATA hard drive.
- SATAu drive carrier — Usable with either a SAS hard drive or a SATA hard drive with a universal interposer card. The interposer card provides enhanced functionality that makes the SATA hard drive usable in some storage systems.

 **NOTICE:** Before attempting to remove or install a drive while the system is running, see the documentation for the SAS controller daughter card to ensure that the host adapter is configured correctly to support hot-plug drive removal and insertion.

 **NOTE:** It is recommended that you use only drives that have been tested and approved for use with the SAS backplane board.

You may need to use different programs than those provided with the operating system to partition and format SATA hard drives.

 **NOTICE:** Do not turn off or reboot your system while the drive is being formatted. Doing so can cause a drive failure.

When you format a high-capacity hard drive, allow enough time for the formatting to be completed. Long format times for these drives are normal.

## Removing a Drive Blank

 **NOTICE:** To maintain proper system cooling, all empty hard-drive bays must have drive blanks installed. If you remove a hard-drive carrier from the system and do not reinstall it, you must replace the carrier with a drive blank.

For 3.5-inch hard drive configurations:

- 1 Remove the front bezel, if attached. See "Removing the Front Bezel" on page 65.
- 2 Insert your finger under the shrouded end of the blank and press in on the latch to eject the blank outward from the bay.
- 3 Pull the ends of the blank outward until the blank is free.

## Installing a Drive Blank

The drive blank is keyed to ensure correct insertion into the drive bay. To install a 3.5-inch drive blank, insert and rotate in the keyed side of the blank into the drive bay and press evenly on the other end of the blank until it is fully inserted and latched.

## Removing a Hot-Plug Hard Drive

- 1 Remove the front bezel, if attached. See "Removing the Front Bezel" on page 65.
- 2 From the RAID management software, prepare the drive for removal and wait until the hard-drive indicators on the drive carrier signal that the drive can be removed safely. See your SAS controller documentation for information about hot-plug drive removal.

If the drive has been online, the green activity/fault indicator will flash as the drive is powered down. When both drive indicators are off, the drive is ready for removal.

- 3 Open the drive carrier release handle to release the drive. See Figure 3-4.
- 4 Slide the hard drive out until it is free of the drive bay.
- 5 If you do not replace the hard drive, insert a drive blank in the vacated drive bay. See "Installing a Drive Blank" on page 70.

 **NOTICE:** To maintain proper system cooling, all empty hard-drive bays must have drive blanks installed.

## Installing a Hot-Plug Hard Drive

 **NOTICE:** When installing a hard drive, ensure that the adjacent drives are fully installed. Inserting a hard-drive carrier and attempting to lock its handle next to a partially installed carrier can damage the partially installed carrier's shield spring and make it unusable.

 **NOTICE:** Not all operating systems support hot-plug drive installation. See the documentation supplied with your operating system.

- 1 Remove the front bezel, if attached. See "Removing the Front Bezel" on page 65.
- 2 If a drive blank is present in the bay, remove it. See "Removing a Drive Blank" on page 69.

- 3 Install the hot-plug hard drive.
  - a Open the handle on the hard-drive carrier.

**Figure 3-4. Installing a Hot-Plug Hard Drive**

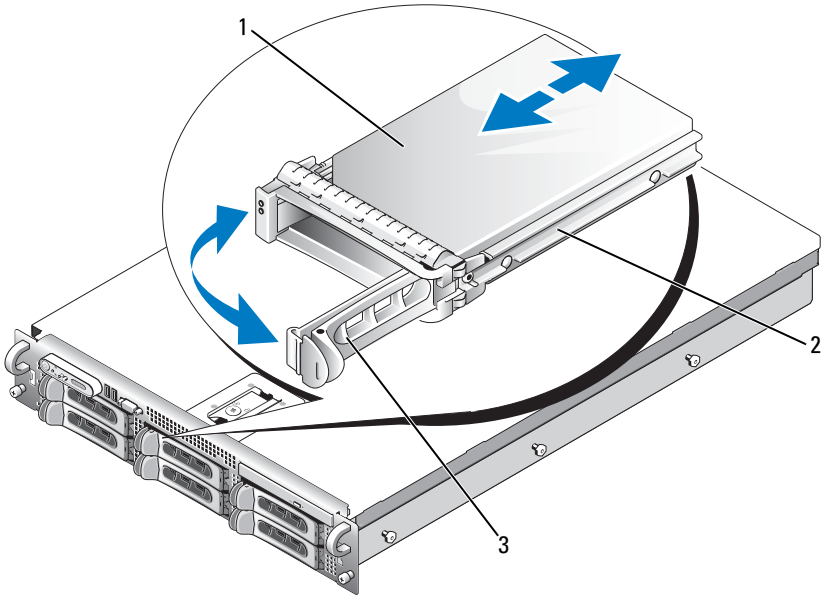

- |   |                              |   |               |
|---|------------------------------|---|---------------|
| 1 | hard drive                   | 2 | drive carrier |
| 3 | drive carrier release handle |   |               |

- b Insert the hard-drive carrier into the drive bay until the carrier contacts the backplane.
    - c Close the handle to lock the drive in place.
- 4 Replace the front bezel, if it was removed in step 1.

# Replacing a Hard-Drive Carrier

## Removing a Hard Drive From a Hard-Drive Carrier

- 1** If you are removing a SATA hard drive from a SATAu drive carrier, remove the interposer card:
  - a** Viewing the hard drive carrier from the rear, locate the release lever on the left end of the interposer card.
  - b** Push the lever away from the carrier rail to release the left end of the card.
  - c** Rotate the left end away from the hard drive to release the connector.
  - d** Pull the right end of the interposer card clear of the slots in the carrier rail.
- 2** Remove the four screws from the slide rails on the hard-drive carrier and separate the hard drive from the carrier.

## Installing a SATA Hard Drive Into a SATA Drive Carrier



**NOTE:** SATA hard drives that connect directly to the SAS backplane must be installed in SATA drive carriers (labeled "SATA").

- 1** Insert the SATA hard drive into the hard-drive carrier with the connector end of the drive at the rear. See Figure 3-5.
- 2** Align the screw holes on the hard drive with the holes on the hard-drive carrier. See Figure 3-5.
- 3** Attach the four screws to secure the hard drive to the hard-drive carrier. See Figure 3-5.



**Figure 3-5. Installing a SATA Hard Drive Into a SATA Drive Carrier**

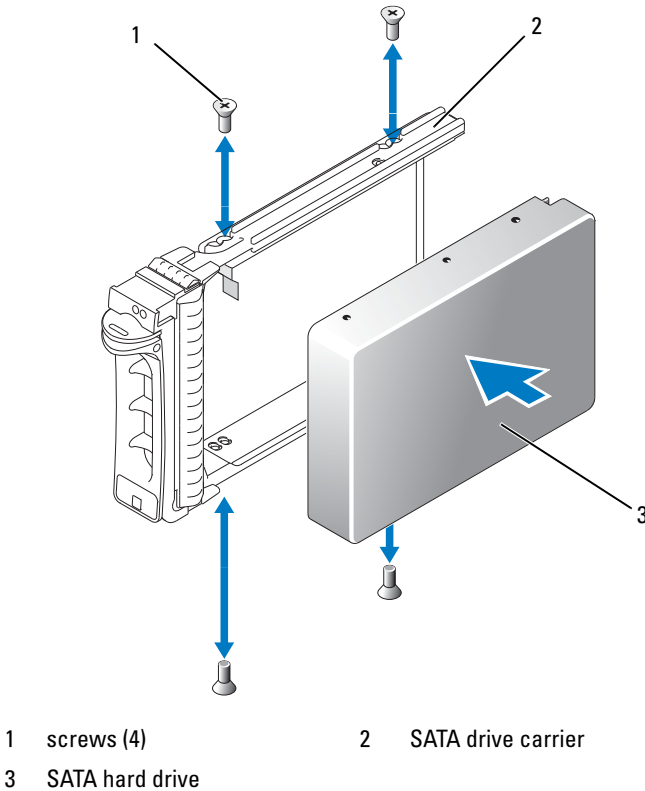

### **Installing a SATA Hard Drive and Interposer Card Into a SATAu Hard-Drive Carrier**



**NOTE:** When you install a SATA hard drive into a SATAu drive carrier, you must install an interposer card onto the back of the hard drive. The SATAu drive carrier is labeled "SATAu" and also has marks indicating the SAS and SATA mounting screws.

- 1 Insert the SATA hard drive into the SATAu hard-drive carrier with the connector end of the drive at the rear. See Figure 3-6.

- 2** Viewing the assembly as shown in Figure 3-6, align the bottom rear screw hole on the hard drive with the hole labeled "SATAu" on the hard drive carrier.

When aligned correctly, the rear of the interposer will be flush with the rear of the hard-drive carrier.

- 3** Attach the four screws to secure the hard drive to the hard-drive carrier. See Figure 3-6.
- 4** Attach the interposer card to the rear of the SATA hard drive:
  - a** Angle the top of the interposer card into the inside top carrier rail so that the tabs on the interposer card bracket attach to the slots on the inside of the carrier rail. See Figure 3-6.
  - b** Rotate the bottom end of the card toward the hard drive to seat the connector. See Figure 3-6.
  - c** Push the bottom end of the card to the hard drive until the latch on the card bracket clicks into place.

**Figure 3-6. Installing a SATA Hard Drive and Interposer Card Into a SATAu Drive Carrier**

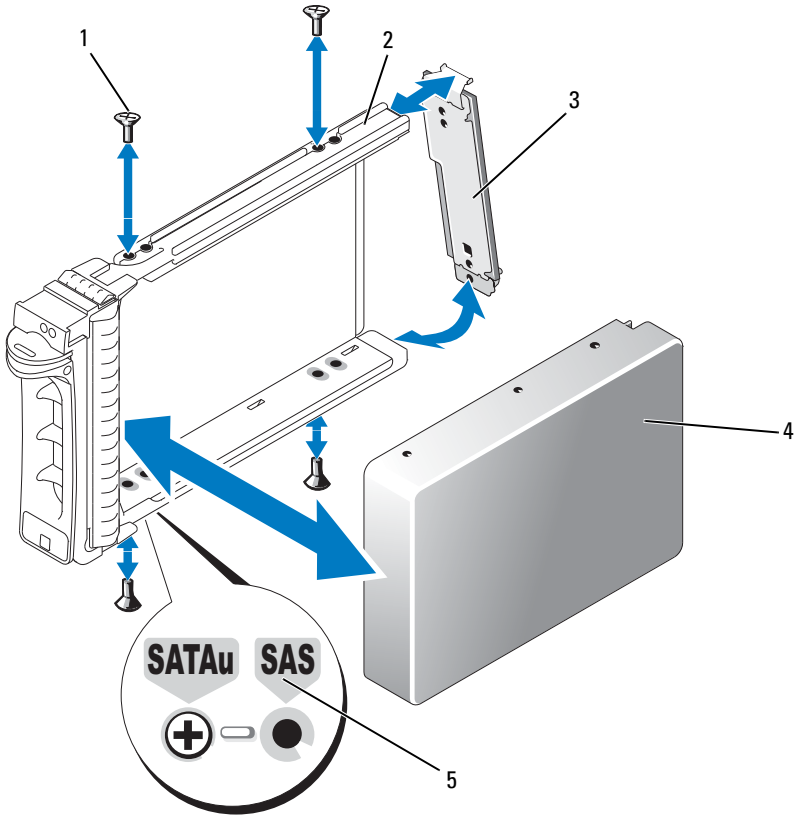

- |   |                             |   |                     |
|---|-----------------------------|---|---------------------|
| 1 | screws (4)                  | 2 | SATAu drive carrier |
| 3 | interposer card (SATA only) | 4 | SATA hard-drive     |
| 5 | hole labels                 |   |                     |

# Power Supplies

Your system supports one or two power supplies rated at an output of 750 W. If only one power supply is installed, it must be installed in the left power supply bay (1). If two power supplies are installed, the second power supply serves as a redundant, hot-plug power source.

 **NOTICE:** To ensure proper system cooling, the power supply blank must be installed on the unoccupied power supply bay in a non-redundant configuration. See "Installing the Power Supply Blank" on page 78.

## Removing a Power Supply

 **NOTICE:** The system requires one power supply for the system to operate normally. The system is in the redundant mode when two power supplies are installed and both power supplies are connected to an AC power source. Remove and replace only one power supply at a time in a system that is powered on. Operating the system with only one power supply installed and without a power supply blank installed for extended periods of time can cause the system to overheat.

 **NOTICE:** If only one power supply is installed, it must be installed in the left power supply bay (1).

 **NOTICE:** If you connect the system to a power source in the range of 120 to 220 VAC, and if two power supplies are installed, the second power supply serves as a redundant, hot-plug power source.

 **NOTE:** On your rack system, you may have to unlatch and lift the cable management arm if it interferes with power supply removal. For information about the cable management arm, see the system's *Rack Installation Guide*.

- 1 If your system has a single power supply, turn off the system and all attached peripherals. For a redundant system, you can leave the system running and proceed to the next step.
- 2 Disconnect the power cable from the power source.
- 3 Disconnect the power cable from the power supply and remove the cable from the cable retention bracket.
- 4 Release the locking tab on the left side of the power supply by pressing in toward the right, and rotate the power-supply handle up until the power supply is released from the chassis. See Figure 3-7.
- 5 Pull the power supply straight out to clear the chassis.

**Figure 3-7. Removing and Installing a Power Supply**

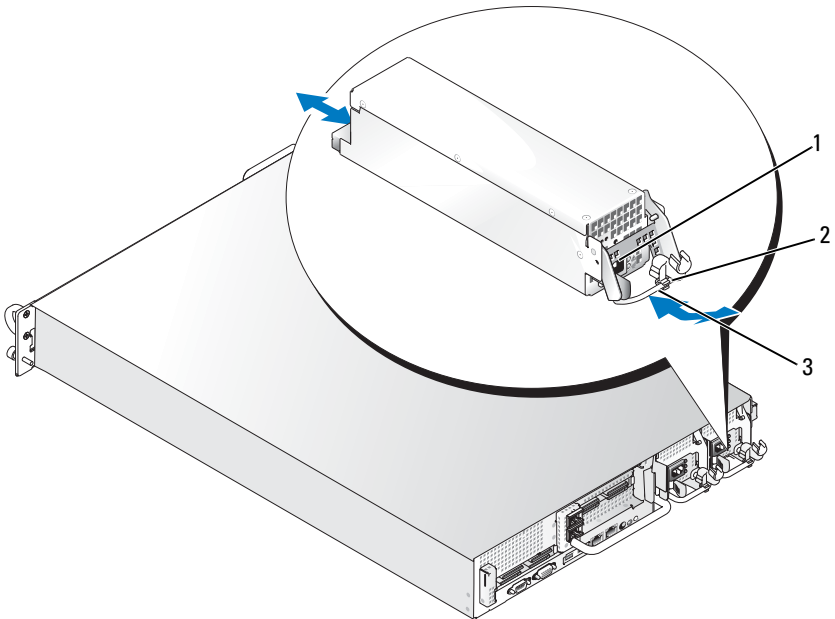

- 1 locking tab
- 2 cable retention bracket
- 3 power-supply handle

## Replacing a Power Supply

- 1 With the power-supply handle in the extended position, slide the new power supply into the chassis. See Figure 3-7.
- 2 Rotate the handle down until it is completely flush with the power-supply faceplate and the orange snap engages. See Figure 3-7.
- 3 Insert the power cable through the cable retention bracket, connect the power cable to the power supply, and plug the cable into a power outlet.



**NOTE:** After installing a new power supply, allow several seconds for the system to recognize the power supply and determine whether it is working properly. The power supply status indicator will turn green to signify that the power supply is functioning properly. See Figure 1-4.

## Removing the Power Supply Blank

Using a Phillips screwdriver, remove the screw on the left side of the blank, rotate the blank slightly to clear the bay, and remove from the chassis.



**NOTICE:** To ensure proper system cooling, the power supply blank must be installed on the unoccupied power supply bay in a non-redundant configuration. Remove the power supply blank only if you are installing a second power supply.

## Installing the Power Supply Blank

To install the power supply blank, insert the tab on the right edge of the blank into the slot in the power supply bay wall. Rotate the blank into the power supply bay and secure with the Phillips screw.

## System Fans

The system includes four hot-pluggable cooling fans.

### Removing a System Fan



**CAUTION:** Many repairs may only be done by a certified service technician. You should only perform troubleshooting and simple repairs as authorized in your product documentation, or as directed by the online or telephone service and support team. Damage due to servicing that is not authorized by Dell is not covered by your warranty. Read and follow the safety instructions that came with the product.



**NOTICE:** The system fans are hot-pluggable. To maintain proper cooling while the system is on, replace only one fan at a time.

- 1 Open the system. See "Opening the System" on page 67.



**CAUTION:** Use caution when handling the fan until the fan blades stop spinning.

- 2 Raise the fan handle and pull the fan straight up from the fan cage to clear the chassis. See Figure 3-8.

**Figure 3-8. Removing and Installing a Cooling Fan**

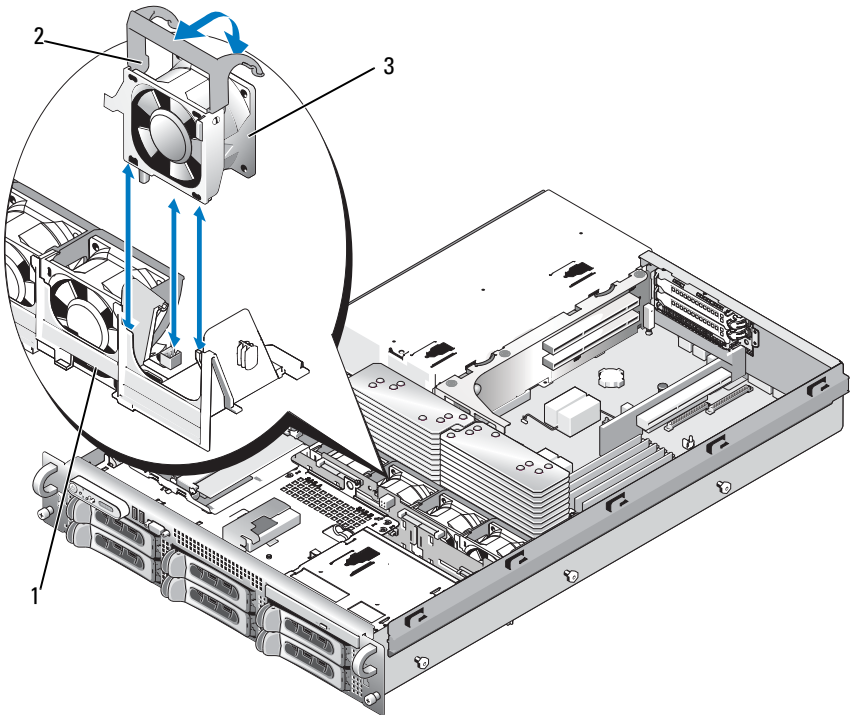

- |   |             |   |            |
|---|-------------|---|------------|
| 1 | fan bracket | 2 | fan handle |
| 3 | fan         |   |            |

### **Replacing a Cooling Fan**

- 1** Ensure that the fan handle is upright and lower the fan into its fan cage until the fan is fully seated. Then lower the fan handle until it snaps into place. See Figure 3-8.
- 2** Close the system. See "Closing the System" on page 67.

# Cooling Shroud

The cooling shroud produces and directs airflow over the system memory modules.

**⚠ CAUTION:** The DIMMs are hot to the touch for some time after the system has been powered down. Allow the DIMMs to cool before handling them.

**➡ NOTICE:** Never operate your system with the memory cooling shroud removed. Overheating of the system can develop quickly resulting in a shutdown of the system and the loss of data.

## Removing the Cooling Shroud

- 1 The cooling shroud is secured with a latch at the end of the shroud. Release the latch by pulling it towards the outside wall of the chassis. See Figure 3-9.
- 2 Rotate the shroud upward and toward the front of the system on its hinges, and then lift the shroud out of the system.

**Figure 3-9. Removing and Installing the Cooling Shroud**

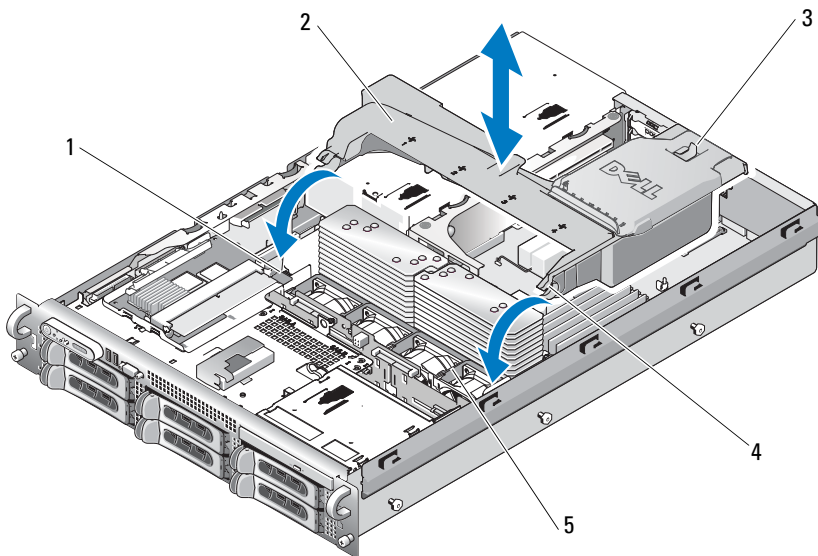

- |   |                   |   |                   |
|---|-------------------|---|-------------------|
| 1 | shroud pivots (2) | 2 | cooling shroud    |
| 3 | release latch     | 4 | shroud hinges (2) |
| 5 | fan bracket       |   |                   |



## Installing the Cooling Shroud

- 1 Align the hinges on the shroud pivots located on either end of the fan bracket. See Figure 3-9.
- 2 Slowly lower the shroud straight down into the system until the fan connector engages and the latches snap into place.

## Fan Brackets

### Removing the Fan Bracket



**CAUTION: Many repairs may only be done by a certified service technician. You should only perform troubleshooting and simple repairs as authorized in your product documentation, or as directed by the online or telephone service and support team. Damage due to servicing that is not authorized by Dell is not covered by your warranty. Read and follow the safety instructions that came with the product.**

- 1 Turn off the system, including any attached peripherals, and disconnect the system from the electrical outlet.
- 2 Open the system. See "Opening the System" on page 67.
- 3 Remove the cooling shroud. See "Removing the Cooling Shroud" on page 80.
- 4 Remove the SAS controller daughter card. See "Removing a SAS Controller Daughter Card" on page 87
- 5 Remove the fans from the fan bracket. See "Removing a System Fan" on page 78.
- 6 Remove the fan bracket from the system:
  - a Press down on the release latch on the left side of the fan bracket. See Figure 3-10.  
If the bracket does not disengage completely, push down slightly on the bracket when releasing the latch.
  - b Rotate the left side of the bracket upward, releasing the plastic clip from its slot in the system board tray.
  - c Draw the bracket out of the system.

**Figure 3-10. Removing and Installing the Fan Bracket**

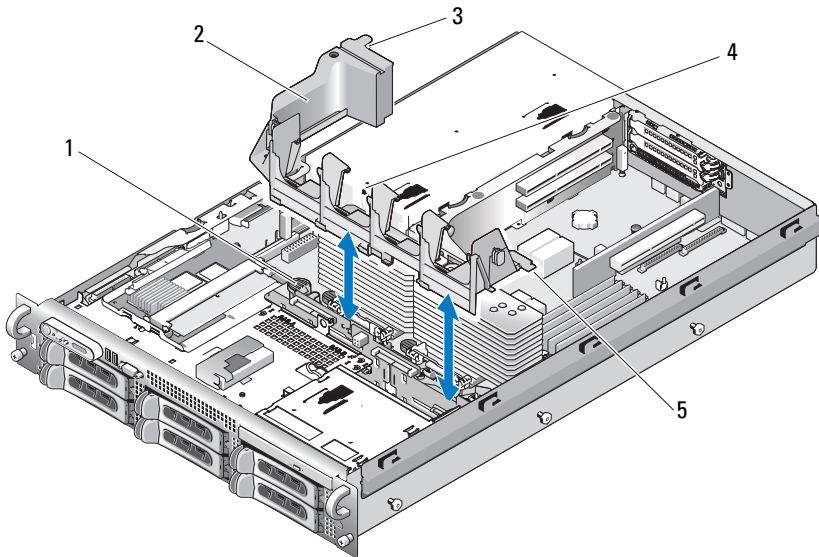

- |   |               |   |                                       |
|---|---------------|---|---------------------------------------|
| 1 | release latch | 2 | fan bracket                           |
| 3 | plastic clip  | 4 | fan bracket slot in power supply cage |
| 5 | tabs (2)      |   |                                       |

## Replacing the Fan Bracket

- 1 Insert the two tabs on the right side of the fan bracket into the two slots on the system board tray.
- 2 Gently rotate the left end of the fan bracket downward into the system until the release latch and plastic clip fully engage.
- 3 Reinstall the SAS controller daughter card. See "Installing a SAS Controller Daughter Card" on page 85.
- 4 Replace the fans in the fan bracket. See "Replacing a Cooling Fan" on page 79.
- 5 Close the system. See "Closing the System" on page 67.
- 6 Reconnect the system to the electrical outlet and turn on the system and attached peripherals.

## Cable Routing

Cables that extend through the system front-to-back are routed along a cable path within the interior right wall of the system chassis. The cables are secured by a cable retention bracket that attaches to the inner wall.

### Removing the Cable Retention Bracket

- 1** Remove the cooling shroud. See "Removing the Cooling Shroud."
- 2** Remove the cooling fan bracket. See "Removing the Fan Bracket."
- 3** Press outward on the blue release latch on the cable retention bracket and slide the bracket back until the tabs at the bottom of the bracket clear the chassis. See Figure 3-11.
- 4** Lift the cable retention bracket off the chassis wall.

**Figure 3-11. Removing and Installing the Cable Retention Bracket**

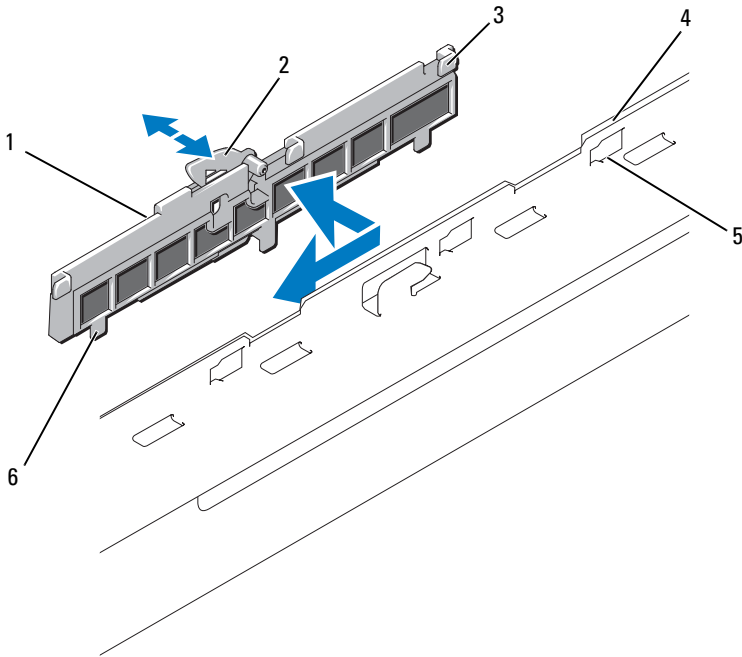

- |   |                         |   |                    |
|---|-------------------------|---|--------------------|
| 1 | cable retention bracket | 2 | release latch      |
| 3 | hooks (3)               | 4 | right chassis wall |
| 5 | chassis slots (6)       | 6 | tab (3)            |

### **Installing the Cable Retention Bracket**

- 1** Insert the hooks and tabs of the cable retention bracket into the slots in the chassis wall and slide the bracket back until the latch engages.
- 2** Install the cooling fan bracket. See "Replacing the Fan Bracket."
- 3** Install the cooling shroud. See "Installing the Cooling Shroud."

# SAS Controller Daughter Card

Your system includes a dedicated slot on the sideplane for a SAS controller daughter card. The SAS controller daughter card provides the SAS storage subsystem for your system's internal hard drives. The SAS controller daughter card is shown in Figure 3-12.

## Installing a SAS Controller Daughter Card

- 1** Turn off the system, including any attached peripherals, and disconnect the system from the electrical outlet.
- 2** Open the system. See "Opening the System" on page 67.
- 3** Disconnect the control panel cable from the sideplane board. See "Removing the Control Panel Assembly" on page 122.
- 4** Hold the SAS daughter card by its edges with the card connector facing the sideplane board.
- 5** Aligning the chassis slots on the SAS daughter card tray with the corresponding hooks on the chassis, insert the card connector into the SAS daughter card connector on the sideplane board. See Figure 3-12.  
Ensure that the card is aligned with the mid-section standoff on the SAS controller daughter card and fully seat the card in the sideplane board.

**Figure 3-12. Installing a SAS Controller Daughter Card**

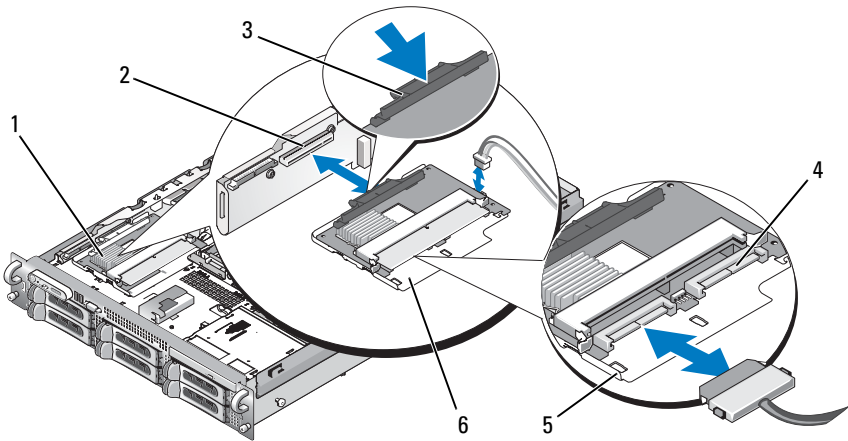

- |   |                              |   |  |
|---|------------------------------|---|--|
| 1 | SAS controller daughter card | 2 | SAS controller daughter card slot                                  |
| 3 | release tab                  | 4 | SAS connectors 0 and 1 out to backplane SAS_A and SAS_B connectors |
| 5 | chassis slots (2)            | 6 | SAS controller daughter card tray                                  |

**6** Attach any cables from the SAS controller daughter card to the backplane, refer to Figure 3-13 for the cabling guidelines for your system's card and backplane configuration.

## SAS Controller Daughter Card Cabling Guidelines

Figure 3-13. SAS Controller Daughter Card Cabling With 3.5-inch x4 Backplane

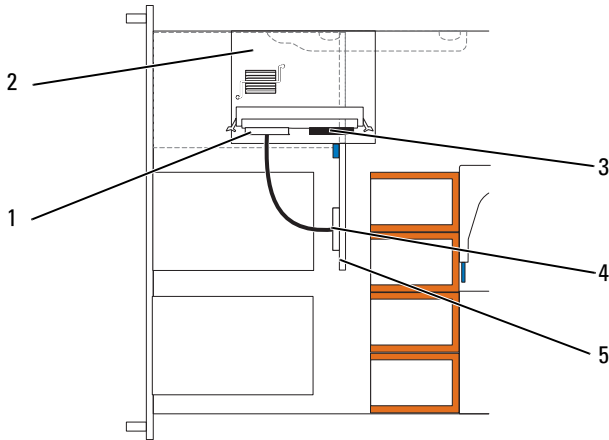

- |   |                       |   |                              |
|---|-----------------------|---|------------------------------|
| 1 | SAS controller 0      | 2 | SAS controller daughter card |
| 3 | SAS controller 1      | 4 | SAS backplane A              |
| 5 | 3.5-inch x4 backplane |   |                              |

### Removing a SAS Controller Daughter Card

- 1 Disconnect the control panel cable. See "Removing the Control Panel Assembly" on page 122
- 2 Disconnect any SAS cables from the card.
- 3 Gently press down on the release tab while sliding the SAS controller daughter card in its tray away from the sideplane connector, freeing the chassis slots on the tray from the chassis hooks, and lifting the card from the system. See Figure 3-12.

## Configuring the Boot Device



**NOTE:** System boot is not supported from an external device attached to a SAS or SCSI adapter. See [support.dell.com](http://support.dell.com) for the latest support information about booting from external devices.

If you plan to boot the system from a hard drive, the drive must be attached to the primary (or boot) controller. The device that the system boots from is determined by the boot order specified in the System Setup program.

The System Setup program provides options that the system uses to scan for installed boot devices. See "Using the System Setup Program" on page 45 for information about the System Setup program.

## Expansion Cards

The system is available with a PCI Express (PCIe) left riser board option. The PCIe left riser board provides one PCIe x8-lane expansion slot and one PCIe x4-lane expansion slot. The half-height center riser board provided with the PCIe left riser board option features one PCIe x8-lane expansion slot. The three expansion card slots are on separate buses.

### Expansion Card Installation Guidelines

To identify expansion slots, see "Expansion-Card Riser-Board Components and PCI Buses" on page 162.



**NOTE:** The expansion-card slots are not hot-pluggable.



**NOTE:** Although the PCIe x4-lane expansion slot on the PCIe left riser option is physically a PCIe x8 connector, it functions only as a PCIe x4-lane slot.



**NOTE:** Slot 1 on the central riser supports half-length expansion cards only. Slots 2 and 3 on the left riser support full-length expansion cards.



**NOTE:** Your system supports up to two RAID expansion cards to manage external storage.

### Installing an Expansion Card



**CAUTION:** Many repairs may only be done by a certified service technician. You should only perform troubleshooting and simple repairs as authorized in your product documentation, or as directed by the online or telephone service and support team. Damage due to servicing that is not authorized by Dell is not covered by your warranty. Read and follow the safety instructions that came with the product.





**NOTE:** The procedure for installing expansion cards into the left and central risers is the same except that there is no card guide for cards installing into the central riser, and only half-height cards are supported on the central riser. Full-length expansion card installation is illustrated in Figure 3-14.

- 1** Unpack the expansion card and prepare it for installation.  
For instructions, see the documentation accompanying the card.
- 2** Turn off the system, including any attached peripherals, and disconnect the system from the electrical outlet.
- 3** Open the system. See "Opening the System" on page 67.
- 4** Open the expansion-card guide latch and remove the filler bracket. See Figure 3-14.
- 5** Install the expansion card:
  - a** If the expansion card is full length, align its front edge with the front card guide. See Figure 3-14.
  - b** Position the expansion card so that the card-edge connector aligns with the expansion-card connector on the expansion-card riser board.
  - c** Insert the card-edge connector firmly into the PCI card connector until the card is fully seated.
  - d** When the card is seated in the connector, close the expansion-card latch. See Figure 3-14.

**Figure 3-14. Installing an Expansion Card**

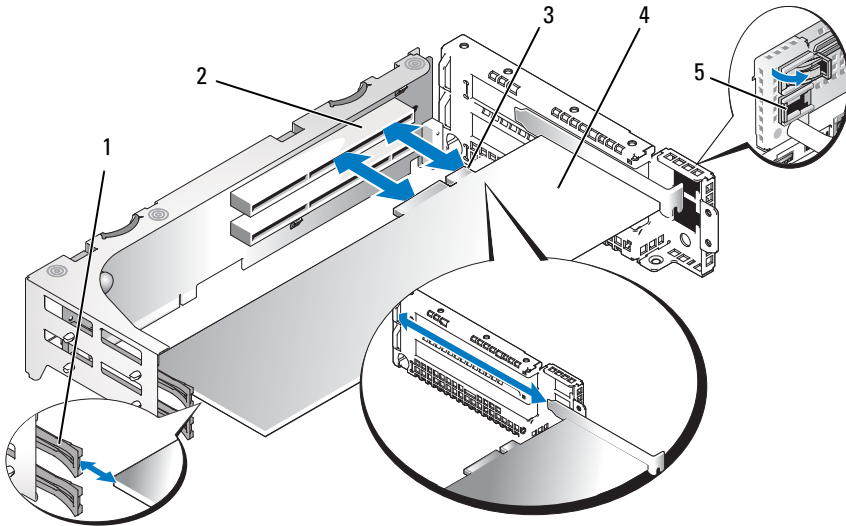

- |   |                            |   |                          |
|---|----------------------------|---|--------------------------|
| 1 | front card guide           | 2 | expansion-card connector |
| 3 | card-edge connector        | 4 | expansion card           |
| 5 | expansion-card guide latch |   |                          |

**6** Connect any expansion-card cables for the new card.

See the documentation that came with the card for information about its cable connections.

**7** Close the system. See "Closing the System" on page 67.

### Removing an Expansion Card



**CAUTION:** Many repairs may only be done by a certified service technician. You should only perform troubleshooting and simple repairs as authorized in your product documentation, or as directed by the online or telephone service and support team. Damage due to servicing that is not authorized by Dell is not covered by your warranty. Read and follow the safety instructions that came with the product.

- 1 Turn off the system, including any attached peripherals, and disconnect the system from the electrical outlet.
- 2 Open the system. See "Opening the System" on page 67.
- 3 Disconnect all expansion-card cables.
- 4 Release the expansion card:
  - a Open the expansion-card latch. See Figure 3-14.
  - b Grasp the expansion card by its top corners, and carefully remove it from the expansion-card connector.
- 5 If you are removing the card permanently, install a metal filler bracket over the empty expansion slot opening and close the expansion-card latch.  
 **NOTE:** You must install a filler bracket over an empty expansion slot to maintain Federal Communications Commission (FCC) certification of the system. The brackets also keep dust and dirt out of the system and aid in proper cooling and airflow inside the system.
- 6 Reconnect all expansion-card cables.
- 7 Close the system. See "Closing the System" on page 67.

## Expansion-Card Cage

### Removing the Expansion-Card Cage



**CAUTION:** Many repairs may only be done by a certified service technician. You should only perform troubleshooting and simple repairs as authorized in your product documentation, or as directed by the online or telephone service and support team. Damage due to servicing that is not authorized by Dell is not covered by your warranty. Read and follow the safety instructions that came with the product.



**NOTE:** You must remove all expansion cards from the expansion-card cage before removing the expansion-card cage from the system.

- 1 Turn off the system, including any attached peripherals, and disconnect the system from the electrical outlet.
- 2 Open the system. See "Opening the System" on page 67.
- 3 Disconnect all expansion-card cables.

- 4 Remove any expansion cards from the expansion-card cage. See "Removing an Expansion Card" on page 90.
- 5 Press the two blue release latches on the expansion-card cage. See Figure 3-15.

**Figure 3-15. Installing and Removing the Expansion-Card Cage**

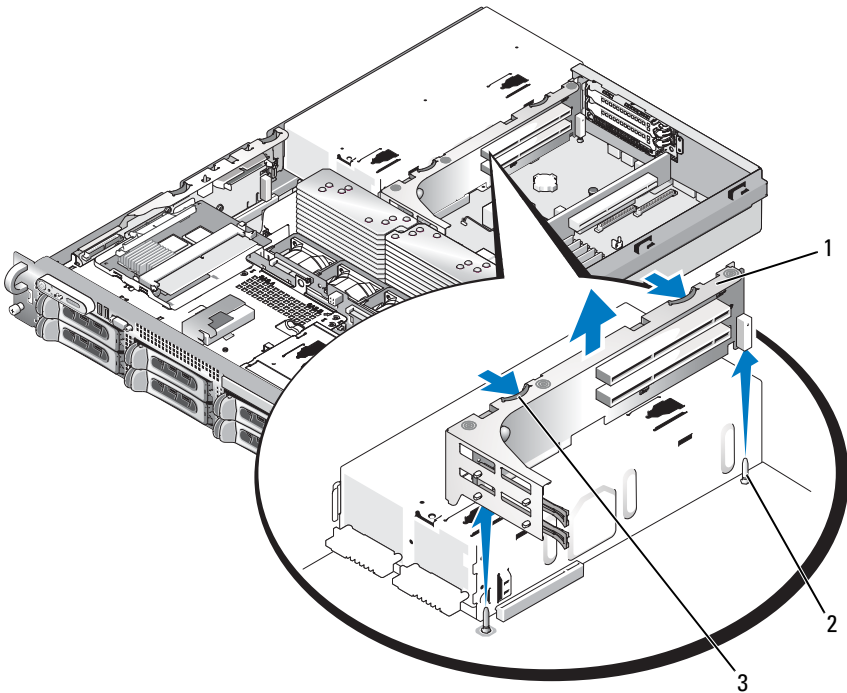

- |   |                     |   |                  |
|---|---------------------|---|------------------|
| 1 | expansion-card cage | 2 | chassis pins (2) |
| 3 | release latches (2) |   |                  |

- 6 Lift the cage straight up to clear the chassis. See Figure 3-15.

## Replacing the Expansion-Card Cage

 **CAUTION:** Many repairs may only be done by a certified service technician. You should only perform troubleshooting and simple repairs as authorized in your product documentation, or as directed by the online or telephone service and support team. Damage due to servicing that is not authorized by Dell is not covered by your warranty. Read and follow the safety instructions that came with the product.

- 1 Align the guides on each end of the expansion-card cage with the pins on the system board, and lower the cage. See Figure 3-15.
- 2 Install any expansion cards.
- 3 Reconnect all expansion-card cables.
- 4 Close the system. See "Closing the System" on page 67.

## DRAC Card and Cables

 **CAUTION:** Many repairs may only be done by a certified service technician. You should only perform troubleshooting and simple repairs as authorized in your product documentation, or as directed by the online or telephone service and support team. Damage due to servicing that is not authorized by Dell is not covered by your warranty. Read and follow the safety instructions that came with the product.

The optional Dell Remote Access Controller (DRAC) provides a set of advanced features for managing the server remotely. The following procedure describes the steps for installing or removing the optional DRAC card and cables.

### Installing the DRAC Card and Cables

- 1 Turn off the system, including any attached peripherals, and disconnect the system from the electrical outlet.
- 2 Open the system. See "Opening the System" on page 67.
- 3 If necessary, remove the plastic filler plug from the system back panel. See Figure 3-16.
- 4 Remove the central riser board. See "Removing the Central Riser Board" on page 114.

- 5 Angle the DRAC card so that its NIC connector inserts through the back-panel DRAC card opening, aligning the card with the back standoff.

**Figure 3-16. Installing and Removing a DRAC Card**

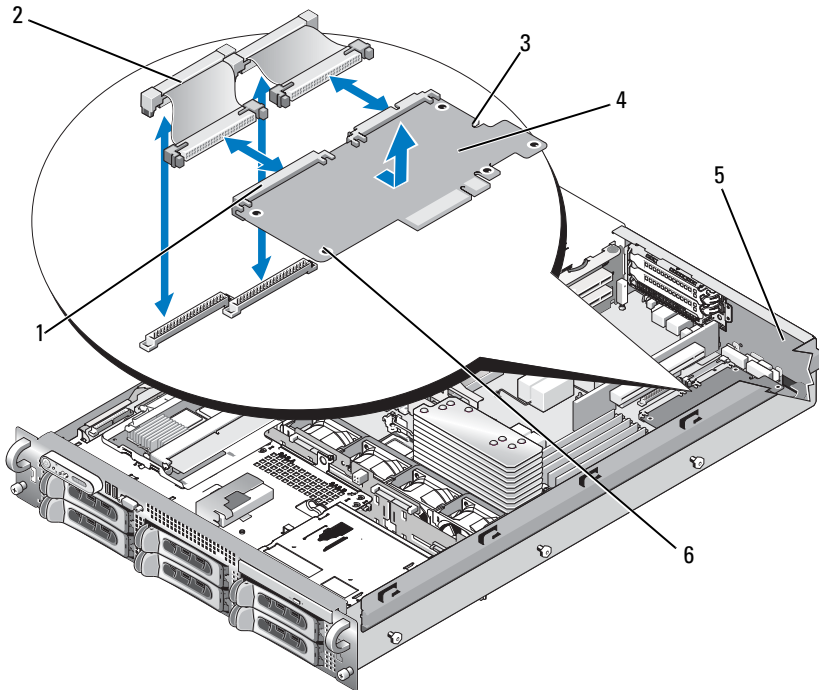

- |                            |                              |
|----------------------------|------------------------------|
| 1 DRAC-card connectors (2) | 2 DRAC-card cables (2)       |
| 3 retention standoff hole  | 4 DRAC card                  |
| 5 filler plug              | 6 support standoffs holes(2) |

- 6 Align the front edge of the DRAC card with the two front plastic retention standoffs adjacent to the DRAC system board connector, and press down the side of the card until it is fully seated. See Figure 3-16.

When the front of the card is fully seated, the front plastic standoffs snap over the front edge of the card.

- 7 Connect the two short ribbon cables to the DRAC card and the system board. See Figure 6-2 for the connector locations

➔ **NOTICE:** Be careful when attaching cables to the system board that you do not damage the surrounding system board components.

- a Connect one cable to connector 1 on the DRAC card and to DRAC\_CONN1 on the system board.
- b Connect the second cable to connector 2 on the DRAC card and to DRAC\_CONN2 on the system board. Reinstall the central riser board. See "Installing the Central Riser Board" on page 115.

➔ **NOTICE:** When detaching the DRAC cables from the system board, squeeze the metal ends of the cable connectors and gently work the connector out of the socket. Do not pull on the cable to unseat the connector. Doing so can damage the cable.

- 8 Add any PCI cards that were removed from the central riser. See "Installing an Expansion Card" on page 88.
- 9 Close the system. See "Closing the System" on page 67.
- 10 Reconnect the system and peripherals to their power sources, and turn them on.

See the DRAC card documentation for information on configuring and using the DRAC card.

## Removing the DRAC Card and Cables

- 1 Turn off the system, including any attached peripherals, and disconnect the system from the electrical outlet.
- 2 Open the system. See "Opening the System" on page 67.
- 3 Remove the central riser board. See "Removing the Central Riser Board" on page 114.
- 4 Remove the DRAC card cables from the system board by squeezing the metal tabs inward and pulling up.
- 5 Remove the DRAC card cables from the DRAC connectors by squeezing the metal tabs inward and pulling out.
- 6 Remove the DRAC card by pressing outward on the front standoffs and lifting the DRAC card out of the system.
- 7 Reinstall the central riser board. See "Installing the Central Riser Board" on page 115.

- 8 Add any PCI cards that were removed from the central riser. See "Installing an Expansion Card" on page 88.
- 9 Close the system. See "Closing the System" on page 67.
- 10 Reconnect the system and peripherals to their power sources, and turn them on.

## Optical Drive and Cable

A slimline optical drive is mounted on a tray that slides in the front panel and connects to the controllers on the system board through the SAS backplane board.

### Removing the Optical Drive



**CAUTION: Many repairs may only be done by a certified service technician. You should only perform troubleshooting and simple repairs as authorized in your product documentation, or as directed by the online or telephone service and support team. Damage due to servicing that is not authorized by Dell is not covered by your warranty. Read and follow the safety instructions that came with the product.**

- 1 Turn off the system, including any attached peripherals, and disconnect the system from its electrical outlet.
- 2 Remove the bezel. See "Removing the Front Bezel" on page 65.
- 3 Open the system. See "Opening the System" on page 67



- 4 Disconnect the optical drive cable from the back of the drive.
- 5 To remove the optical drive, press down and forward on the blue tray release tab and slide the drive tray out of the system. See Figure 3-17.

**Figure 3-17. Removing and Installing the Optical Drive Tray**

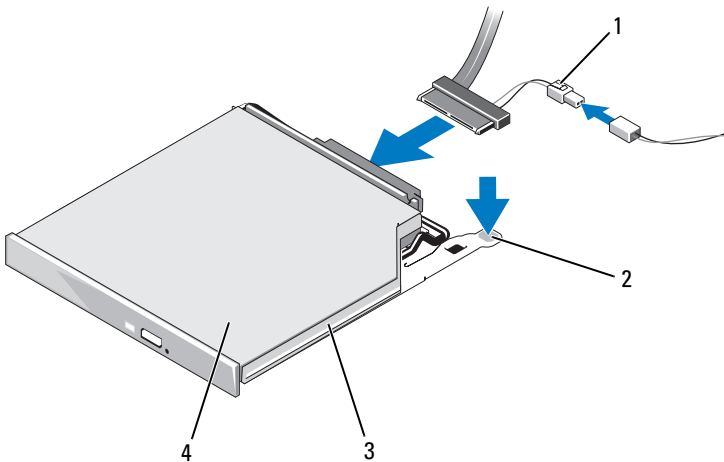

- |   |                     |   |                           |
|---|---------------------|---|---------------------------|
| 1 | optical-drive cable | 2 | optical-drive release tab |
| 3 | optical -drive tray | 4 | optical drive             |

### Installing the Optical Drive

- 1 Insert the optical drive tray into the system until it is fully inserted and locked into position.
- 2 Connect the SATA cable (the end with the branching power cable) to the back of the optical drive.
- 3 Connect the branching power cable to the power supply connector.
- 4 Remove the cooling shroud. See "Removing the Cooling Shroud" on page 80.

- 5 Remove the cable retention bracket from the right interior wall of the chassis. Push the blue release latch and push the bracket toward the front of the system until the bracket detaches from the chassis slots.
- 6 Route the SATA cable in the cable channel in the right wall of the chassis and replace the cable bracket over the cable. See Figure 3-18.

**Figure 3-18. SATA Cable Routing in the PowerVault DL2000**

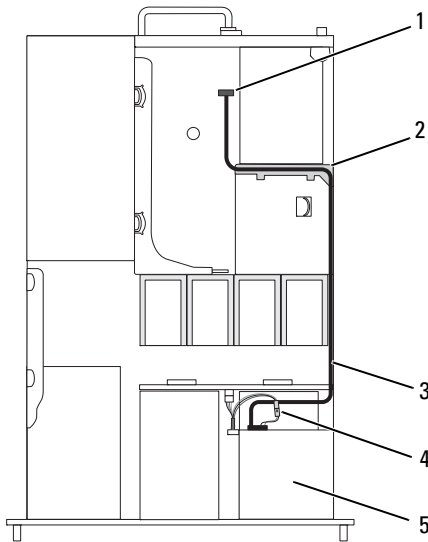

- |   |                                  |   |                  |
|---|----------------------------------|---|------------------|
| 1 | SATA_B connector on system board | 2 | SATA data cable  |
| 3 | system fans                      | 4 | SATA power cable |
| 5 | optical drive                    |   |                  |

- 7 Route the SATA cable along the top of the cable retention bracket to the central riser.
- 8 Bend the cable behind the central riser and connect the cable to the SATA\_A connector on the system board.

## Removing the Optical Drive Cable



**CAUTION: Many repairs may only be done by a certified service technician. You should only perform troubleshooting and simple repairs as authorized in your product documentation, or as directed by the online or telephone service and support team. Damage due to servicing that is not authorized by Dell is not covered by your warranty. Read and follow the safety instructions that came with the product.**

- 1 Turn off the system, including any attached peripherals, and disconnect the system from its electrical outlet.
- 2 Remove the bezel. See "Removing the Front Bezel" on page 65.
- 3 Open the system. See "Opening the System" on page 67.
- 4 Release the CD-to-side plane cable from the side plane by pressing outward on the optical drive data cable ejectors until they reach the locked position.
- 5 Remove the cable from the cable guides on the cooling shroud.
- 6 Remove the CD-to-side plane cable from the back of the optical drive. See Figure 3-17.

## Installing the Optical Drive Cable

- 1 Connect the CD-to-side plane cable (labeled CD) to the back of the optical drive.
- 2 Route the cable on the side of the cooling shroud and then through the cable guides on the cooling shroud.
- 3 With the optical drive data cable ejectors in the open position on the side plane, insert the cable (labeled sideplane) into the connector until the ejectors lock.
- 4 Close the system. See "Closing the System" on page 67.
- 5 Reconnect the system and peripherals to their power sources, and turn them on.

# System Memory

You can upgrade your system memory to a maximum of 16 GB by installing 667MHz fully buffered (FB) DDR II memory modules in sets of 1-GB or 2-GB. The eight memory sockets are located on the system board under the cooling shroud adjacent to the power supply bays. See Figure 6-2. You can purchase memory upgrade kits from Dell.



**NOTICE:** If you remove your original memory modules from the system during a memory upgrade, keep them separate from any new memory modules that you may have, even if you purchased the new memory modules from Dell. Use only 667 MHz DDR II FB-DIMMs.

The memory module sockets are divided into two equal branches (0 and 1). Each branch consists of two channels:

- Channel 0 and channel 1 are in branch 0.
- Channel 2 and channel 3 are in branch 1.

Each channel consists of two DIMM sockets:

- Channel 0 contains DIMM\_1, DIMM\_5.
- Channel 1 contains DIMM\_2, DIMM\_6.
- Channel 2 contains DIMM\_3, DIMM\_7.
- Channel 3 contains DIMM\_4, DIMM\_8.

The first DIMM socket of each channel has white release tabs.

## General Memory Module Installation Guidelines

To ensure optimal performance of your system, observe the following guidelines when configuring your system memory.

- Use only qualified Fully-Buffered DIMMs (FBDs). FBDs can be either single-ranked or dual-ranked. FBDs marked with a 1R are single-ranked and modules marked with a 2R are dual-ranked.
- A minimum of two identical FBDs must be installed.
- DIMM sockets must be populated by lowest number first.
- FBDs must be installed in pairs of matched memory size, speed, and technology, and the total number of FBDs in the configuration must total two, four, or eight. For best system performance, all four, or eight FBDs should be identical memory size, speed, and technology.

- Memory sparing and memory mirroring require eight FBDs, and all FBDs must be of identical memory size, speed, and technology.
- Memory sparing and memory mirroring cannot be implemented at the same time.

## Non-Optimal Memory Configurations

System performance can be affected if your memory configuration does not conform to the preceding installation guidelines. Your system may issue an error message during startup stating that your memory configuration is non-optimal.

## Memory Sparing Support

The system supports memory sparing if eight identical memory modules are installed in the system. The memory sparing feature must be enabled in the System Setup program and can be used only if memory mirroring is not enabled.

Memory sparing allocates four ranks of DIMM memory to the spare bank. These four ranks consist of the first rank of memory in DIMM sockets 1 through 4. For single-rank DIMMs, the entire capacity of the four DIMMs is allocated to sparing whereas for dual-rank DIMMs, only half of the four-DIMM capacity is allocated to sparing. Table 3-1 shows how memory sparing splits the available and spared memory in each of the single- and dual-ranked memory module combinations.

**Table 3-1. Memory Sparing Configurations**

DIMMs	Size/Type	Total Memory	Available	Spare
8	1-GB single-rank	8 GB	4 GB	4 GB
8	2-GB single-rank	16 GB	8 GB	8 GB
8	2-GB dual-rank	16 GB	12 GB	4 GB

## Memory Mirroring Support

The system supports memory mirroring if eight identical memory modules are installed in the system. Mirroring must be enabled in the System Setup program and can be used only if memory sparing is not enabled. In a mirrored configuration, the total available system memory is one-half of the total installed memory.

## Installing Memory Modules



**CAUTION:** Many repairs may only be done by a certified service technician. You should only perform troubleshooting and simple repairs as authorized in your product documentation, or as directed by the online or telephone service and support team. Damage due to servicing that is not authorized by Dell is not covered by your warranty. Read and follow the safety instructions that came with the product.

- 1 Turn off the system, including any attached peripherals, and disconnect the system from the electrical outlet.
- 2 Open the system. See "Opening the System" on page 67.
- 3 Remove the memory cooling shroud. See "Removing the Cooling Shroud" on page 80.



**NOTICE:** Never remove the memory cooling shroud without first powering down the system. Overheating of the system can develop quickly resulting in a shutdown of the system and the loss of data.

- 4 Locate the memory module sockets on the system board. See Figure 6-2.



**CAUTION:** The DIMMs are hot to the touch for some time after the system has been powered down. Allow time for the DIMMs to cool before handling them. Handle the DIMMs by the card edges and avoid touching the DIMM components.

- 5 Press the ejectors on the memory module socket down and out, as shown in Figure 3-19, to allow the memory module to be inserted into the socket.

**Figure 3-19. Installing and Removing a Memory Module**

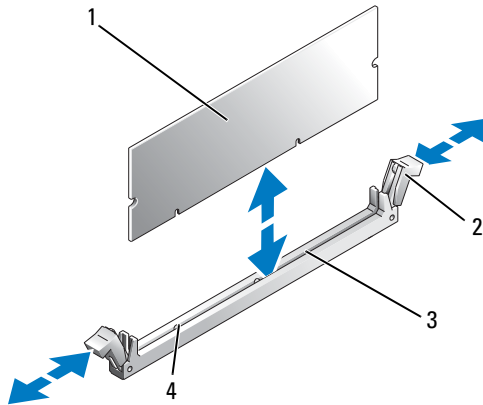

- |   |               |   |                                   |
|---|---------------|---|-----------------------------------|
| 1 | memory module | 2 | memory module socket ejectors (2) |
| 3 | socket        | 4 | alignment key                     |

- 6** Align the memory module's edge connector with the alignment key on the memory module socket, and insert the memory module in the socket.

 **NOTE:** The memory module socket has an alignment key that allows you to install the memory module in the socket in only one way.

- 7** Press down on the memory module with your thumbs while pulling up on the ejectors with your index fingers to lock the memory module into the socket.

When the memory module is properly seated in the socket, the ejectors on the memory module socket align with the ejectors on the other sockets that have memory modules installed.

- 8** Repeat step 3 through step 7 of this procedure to install the remaining memory modules.

- 9 Replace the memory cooling shroud. See "Installing the Cooling Shroud" on page 81.
-  **NOTICE:** Never operate your system with the memory cooling shroud removed. Overheating of the system can develop quickly resulting in a shutdown of the system and the loss of data.
- 10 Close the system. See "Opening the System" on page 67.
- 11 (Optional) Enter the System Setup program, and check the **System Memory** setting on the main **System Setup** screen. See "Entering the System Setup Program" on page 45.  
The system should have already changed the value to reflect the newly installed memory.
- 12 If the value is incorrect, one or more of the memory modules may not be installed properly. Repeat step 2 through step 11 of this procedure, checking to ensure that the memory modules are firmly seated in their sockets.
- 13 Run the system memory test in the system diagnostics. See "Running the System Diagnostics" on page 154.

## Removing Memory Modules

 **CAUTION:** Many repairs may only be done by a certified service technician. You should only perform troubleshooting and simple repairs as authorized in your product documentation, or as directed by the online or telephone service and support team. Damage due to servicing that is not authorized by Dell is not covered by your warranty. Read and follow the safety instructions that came with the product.

- 1 Turn off the system, including any attached peripherals, and disconnect the system from the electrical outlet.
  - 2 Open the system. See "Opening the System" on page 67.
  - 3 Remove the memory cooling shroud. See "Removing the Cooling Shroud" on page 80.
-  **NOTICE:** Never remove the memory cooling shroud without first powering down the system. Overheating of the system can develop quickly resulting in a shutdown of the system and the loss of data.



- 4 Locate the memory module sockets on the system board. See Figure 6-2.



**CAUTION: The DIMMs are hot to the touch for some time after the system has been powered down. Allow the DIMMs to cool before handling them. Handle the DIMMs by the card edges, and avoid touching the DIMM components.**

- 5 Press down and out on the ejectors on each end of the socket until the memory module pops out of the socket. See Figure 3-19.
  - 6 Replace the memory cooling shroud. See "Installing the Cooling Shroud" on page 81.
-  **NOTICE:** Never operate your system with the memory cooling shroud removed. Overheating of the system can develop quickly resulting in a shutdown of the system and the loss of data.
- 7 Close the system. See "Closing the System" on page 67.

## Activating the Integrated NIC TOE

To add TCP/IP Offload Engine (TOE) or iSCSI TOE functionality to the system's integrated NIC, install the appropriate TOE or iSCSI TOE NIC hardware key in the TOE\_KEY socket on the system board (see Figure 6-2.)

## Processors



You can upgrade your processor(s) to take advantage of future options in speed and functionality. Each processor and its associated internal cache memory are contained in a land grid array (LGA) package that is installed in a ZIF socket on the system board.

### Removing a Processor



**CAUTION: Many repairs may only be done by a certified service technician. You should only perform troubleshooting and simple repairs as authorized in your product documentation, or as directed by the online or telephone service and support team. Damage due to servicing that is not authorized by Dell is not covered by your warranty. Read and follow the safety instructions that came with the product.**

- 1 Prior to upgrading your system, download the latest system BIOS version on [support.dell.com](http://support.dell.com).

- 2 Turn off the system, including any attached peripherals, and disconnect the system from the electrical outlet.
  - 3 Open the system. See "Opening the System" on page 67.
  - 4 Remove the fans. See "Removing a System Fan" on page 78
  - 5 Remove the fan bracket. See "Removing the Fan Bracket" on page 81.
-  **NOTICE:** When you remove the heat sink, the possibility exists that the processor might adhere to the heat sink and be removed from the socket. It is recommended that you remove the heat sink while the processor is still warm.
-  **NOTICE:** Never remove the heat sink from a processor unless you intend to remove the processor. The heat sink is necessary to maintain proper thermal conditions.
- 6 Press the blue tab on the end of one of the heat-sink retention levers to disengage the lever, then lift the lever 90 degrees. See Figure 3-20.

**Figure 3-20. Installing and Removing the Heat Sink**

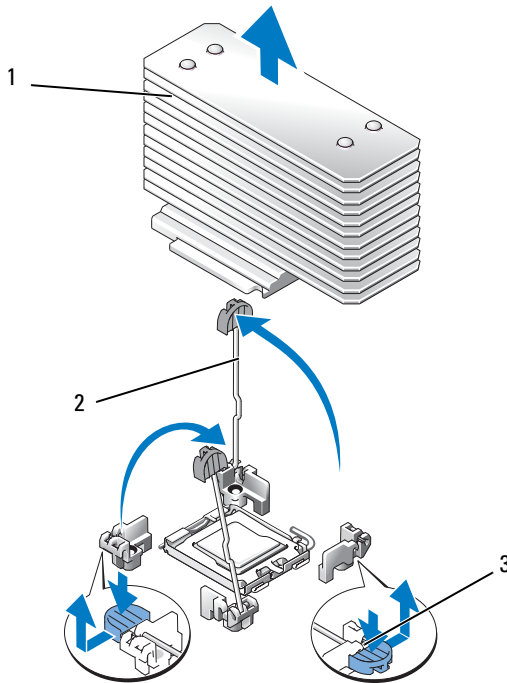

- 1 heat sink
- 2 heat-sink retention levers (2)
- 3 retention lever latch

- 7 Wait 30 seconds for the heat sink to loosen from the processor.
- 8 Open the other heat sink retention lever.
- 9 If the heat sink has not separated from the processor, carefully rotate the heat sink in a clockwise, then counterclockwise direction until it releases from the processor. Do not pry the heat sink from the processor.
- 10 Lift the heat sink off of the processor and set the heat sink aside.
- 11 Pull the socket-release lever 90 degrees upward until the processor is released from the socket. See Figure 3-21.
- 12 Rotate the processor shield upward and out of the way.

**Figure 3-21. Installing and Removing a Processor**

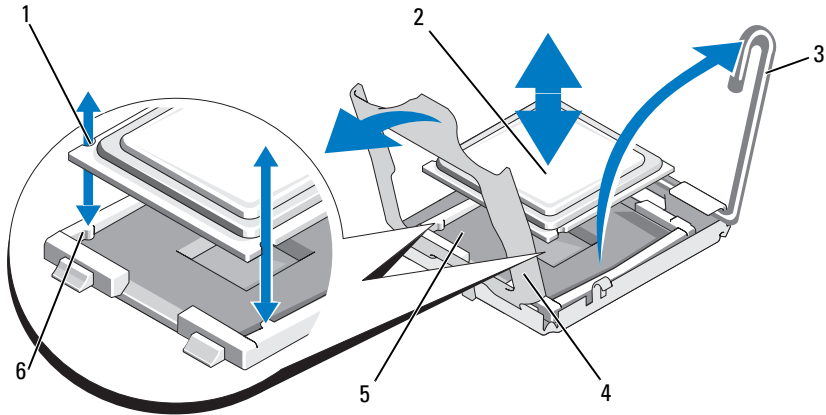

- |                          |                    |
|--------------------------|--------------------|
| 1 notch in processor (2) | 2 processor        |
| 3 socket-release lever   | 4 processor shield |
| 5 ZIF socket             | 6 socket key (2)   |

**13** Lift the processor out of the socket and leave the release lever up so that the socket is ready for the new processor.

**➔ NOTICE:** Be careful not to bend any of the pins on the ZIF socket when removing the processor. Bending the pins can permanently damage the system board.

### Installing a Processor

- 1 Unpack the new processor.
- 2 Align the processor with the socket keys on the ZIF socket. See Figure 3-21.
- 3 Install the processor in the socket.

**➔ NOTICE:** Positioning the processor incorrectly can permanently damage the system board or the processor when you turn it on. When placing the processor in the socket, be careful not to bend the pins in the socket.

- a If the release lever on the processor socket is not positioned all the way up, move it to that position.





See "Running the System Diagnostics" on page 154 for information about running the diagnostics.

## System Battery

The system battery is a 3.0-volt (V), coin-cell battery.

### Replacing the System Battery

 **CAUTION:** Many repairs may only be done by a certified service technician. You should only perform troubleshooting and simple repairs as authorized in your product documentation, or as directed by the online or telephone service and support team. Damage due to servicing that is not authorized by Dell is not covered by your warranty. Read and follow the safety instructions that came with the product.

 **CAUTION:** There is a danger of a new battery exploding if it is incorrectly installed. Replace the battery only with the same or equivalent type recommended by the manufacturer. Discard used batteries according to the manufacturer's instructions. See your *System Information Guide* for additional information.

- 1 Turn off the system, including any attached peripherals, and disconnect the system from the electrical outlet.
- 2 Open the system. See "Opening the System" on page 67
- 3 Locate the battery socket. See "System Board Connectors" on page 158.

 **NOTICE:** If you pry the battery out of its socket with a blunt object, be careful not to touch the system board with the object. Ensure that the object is inserted between the battery and the socket before you attempt to pry out the battery. Otherwise, you may damage the system board by prying off the socket or by breaking circuit traces on the system board.

 **NOTICE:** To avoid damage to the battery connector, you must firmly support the connector while installing or removing a battery.

- 4 Remove the system battery.
  - a Support the battery connector by pressing down firmly on the positive side of the connector.
  - b While supporting the battery connector, press the battery toward the positive side of the connector and pry it up out of the securing tabs at the negative side of the connector.

**Figure 3-22. Replacing the System Battery**

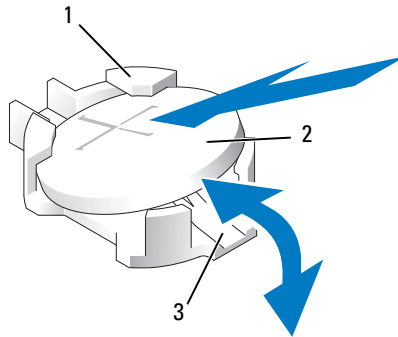

- 1 positive side of battery connector      2 system battery  
3 negative side of battery connector

➔ **NOTICE:** To avoid damage to the battery connector, you must firmly support the connector while installing or removing a battery.

- 5 Install the new system battery.
  - a Support the battery connector by pressing down firmly on the positive side of the connector.
  - b Hold the battery with the "+" facing up, and slide it under the securing tabs at the positive side of the connector.
  - c Press the battery straight down into the connector until it snaps into place.
- 6 Close the system. See "Closing the System" on page 67.
- 7 Reconnect the system to its electrical outlet and turn the system on, including any attached peripherals.
- 8 Enter the System Setup program to confirm that the battery is operating properly. See "Entering the System Setup Program" on page 45.
- 9 Enter the correct time and date in the System Setup program's **Time** and **Date** fields.
- 10 Exit the System Setup program.

- 11 To test the newly installed battery, turn off the system and disconnect it from the electrical outlet for at least an hour.
- 12 After an hour, reconnect the system to its electrical outlet and turn it on.
- 13 Enter the System Setup program and if the time and date are still incorrect, see "Getting Help" on page 167 for instructions on obtaining technical assistance.

## Expansion-Card Riser Boards

### Removing the Left Expansion-Card Riser Board



**CAUTION:** Many repairs may only be done by a certified service technician. You should only perform troubleshooting and simple repairs as authorized in your product documentation, or as directed by the online or telephone service and support team. Damage due to servicing that is not authorized by Dell is not covered by your warranty. Read and follow the safety instructions that came with the product.

- 1 Turn off the system and attached peripherals, and disconnect the system from the electrical outlet.
- 2 Open the system. See "Opening the System" on page 67.
- 3 Remove any expansion cards from the left riser expansion-card slots. See "Removing an Expansion Card" on page 90.
- 4 Remove the expansion-card cage. See "Removing the Expansion-Card Cage" on page 91.
- 5 Remove the expansion-card riser board:
  - a Pull the expansion-card riser release pin. See Figure 3-23.
  - b While pulling the release pin, slide the riser board away from the expansion card openings.
  - c Lift the riser board from the six securing tabs.



**Figure 3-23. Replacing the Left Riser Board**

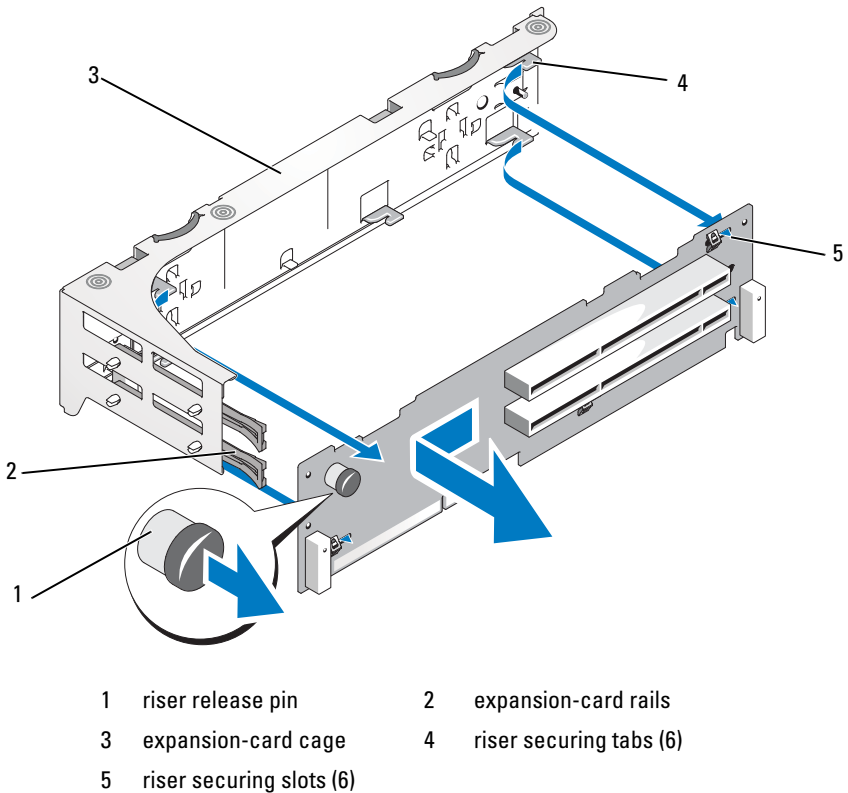

### Installing the Left Riser Board

**⚠ CAUTION:** Many repairs may only be done by a certified service technician. You should only perform troubleshooting and simple repairs as authorized in your product documentation, or as directed by the online or telephone service and support team. Damage due to servicing that is not authorized by Dell is not covered by your warranty. Read and follow the safety instructions that came with the product.

- 1 Place the riser board in the expansion-card cage so that the six securing tabs are fully inserted in the six securing slots on the riser board. See Figure 3-23.

- 2 Slide the riser board toward the expansion card openings until you feel the riser-board release pin snap into place.
- 3 Replace the expansion-card cage. See "Replacing the Expansion-Card Cage" on page 93.
- 4 Install all expansion cards in the expansion-card slots. See "Installing an Expansion Card" on page 88.
- 5 Close the system. See "Closing the System" on page 67.

## Removing the Central Riser Board



**CAUTION: Many repairs may only be done by a certified service technician. You should only perform troubleshooting and simple repairs as authorized in your product documentation, or as directed by the online or telephone service and support team. Damage due to servicing that is not authorized by Dell is not covered by your warranty. Read and follow the safety instructions that came with the product.**

- 1 Turn off the system and attached peripherals, and disconnect the system from the electrical outlet.
- 2 Open the system. See "Opening the System" on page 67.
- 3 Remove the optical drive cable. See "Removing the Optical Drive Cable" on page 99.
- 4 Remove the cooling shroud. See "Removing the Cooling Shroud" on page 80.
- 5 Remove the cable retention bracket. See "Removing the Cable Retention Bracket" on page 83.
- 6 Remove any peripheral cards from the central riser. See "Removing an Expansion Card" on page 90.
- 7 Press the blue release tab in the center of the central riser to release the board from the system board socket while easing both ends of the riser upward.
- 8 Lift the central riser board from the two guide pins on either end, and draw the riser away from the system board. See Figure 3-23.

**Figure 3-24. Installing the Central Riser Board**

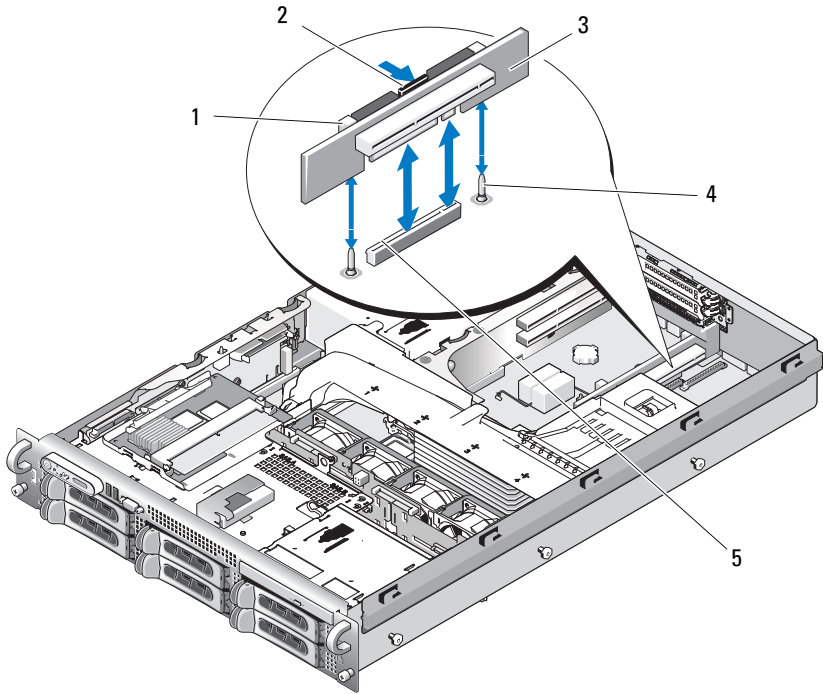

- |   |                     |   |                |
|---|---------------------|---|----------------|
| 1 | card guide (2)      | 2 | release tab    |
| 3 | central riser board | 4 | guide pins (2) |
| 5 | system board socket |   |                |

### **Installing the Central Riser Board**

- 1** Fitting the two guides over the guide pins on the system board, gently lower the central riser board until the board connector is firmly seated into the system board socket. See Figure 3-24.
- 2** Replace any PCI cards that were removed from the central riser. See "Installing an Expansion Card" on page 88.
- 3** Replace the cable retention bracket. See "Installing the Cable Retention Bracket" on page 84.

- 4 Replace the cooling shroud. See "Installing the Cooling Shroud" on page 81.
- 5 Install the optical drive cable. See "Removing the Optical Drive Cable" on page 99.
- 6 Close the system. See "Closing the System" on page 67.
- 7 Reconnect the system and peripherals to their power sources, and turn them on.

## Sideplane Board

### Removing the Sideplane Board



**CAUTION: Many repairs may only be done by a certified service technician. You should only perform troubleshooting and simple repairs as authorized in your product documentation, or as directed by the online or telephone service and support team. Damage due to servicing that is not authorized by Dell is not covered by your warranty. Read and follow the safety instructions that came with the product.**

- 1 Turn off the system and attached peripherals, and disconnect the system from the electrical outlet.
- 2 Open the system. See "Opening the System" on page 67.
- 3 Remove the SAS controller daughter card. See "Removing a SAS Controller Daughter Card" on page 87.
- 4 Remove any cables from the sideplane board.
- 5 Pressing inward on the sideplane release tabs, lift the sideplane up and away from the system. See Figure 3-25

**Figure 3-25. Sideplane Removal and Installation**

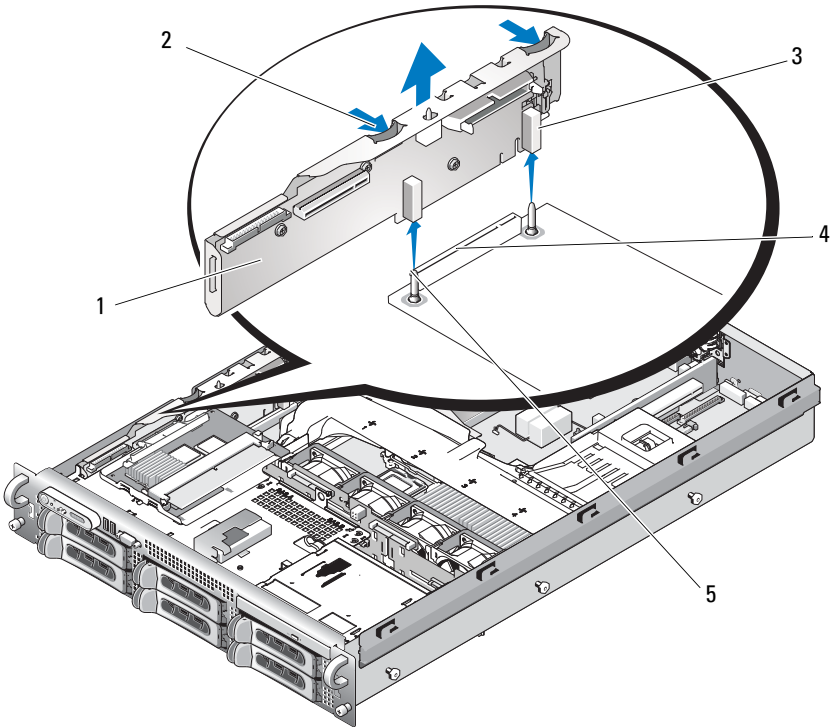

1 sideplane board

2 sideplane release tabs (2)

3 guides (2)

4 backplane connector

5 pins (2)

## Installing the Sideplane Board



**CAUTION: Many repairs may only be done by a certified service technician. You should only perform troubleshooting and simple repairs as authorized in your product documentation, or as directed by the online or telephone service and support team. Damage due to servicing that is not authorized by Dell is not covered by your warranty. Read and follow the safety instructions that came with the product.**

- 1 Turn off the system and attached peripherals, and disconnect the system from the electrical outlet.
- 2 Align the two guides on the sideplane board with the two pins on the SAS backplane board, and gently lower the sideplane so that the sideplane connector is fully seated into the SAS backplane board connector. See Figure 3-25.
- 3 Reattach any cables to the sideplane board.
- 4 If applicable, replace the storage controller daughter card. See "Installing a SAS Controller Daughter Card" on page 85.
- 5 Close the system. See "Closing the System" on page 67.

## SAS Backplane Board

### Removing the SAS Backplane Board



**CAUTION: Many repairs may only be done by a certified service technician. You should only perform troubleshooting and simple repairs as authorized in your product documentation, or as directed by the online or telephone service and support team. Damage due to servicing that is not authorized by Dell is not covered by your warranty. Read and follow the safety instructions that came with the product.**

- 1 Turn off the system and attached peripherals, and disconnect the system from the electrical outlet.
- 2 Open the system. See "Opening the System" on page 67.
- 3 If applicable, disconnect the optical drive from the SAS backplane board. See "Removing the Optical Drive" on page 96.
- 4 Remove the hard drives. See "Removing a Hot-Plug Hard Drive" on page 70.



**NOTE:** To properly reinstall the hard drives, ensure that you record which hard drive you remove from which bay.

- 5** Disconnect the SAS cable(s) and control panel cable from the backplane connectors. See "SAS Controller Daughter Card Cabling Guidelines" on page 87 and "Removing the Control Panel Assembly" on page 122.
- 6** If applicable, remove the storage controller daughter card. See "Removing a SAS Controller Daughter Card" on page 87.
- 7** Remove the cooling shroud. See "Removing the Cooling Shroud" on page 80.
- 8** Remove the fans. See "Removing a System Fan" on page 78
- 9** Remove the fan bracket. See "Removing the Fan Bracket" on page 81.
- 10** Remove the SAS backplane board:
  - a** Pull the SAS-backplane board release pin. See Figure 3-26.
  - b** While pulling the release pin, tilt the backplane board toward the back of the system.
  - c** Lift the backplane board from its securing tabs and remove the backplane board from the chassis.

**Figure 3-26. SAS Backplane Board Removal**

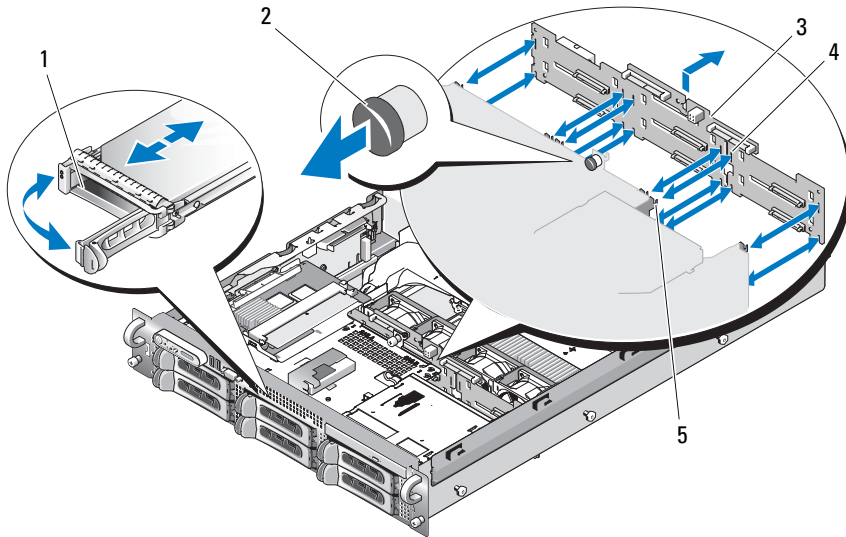

- |   |                     |   |                                 |
|---|---------------------|---|---------------------------------|
| 1 | drive carrier       | 2 | SAS-backplane board release pin |
| 3 | SAS backplane board | 4 | securing slots (10)             |
| 5 | securing tabs (10)  |   |                                 |

## Installing the SAS Backplane Board

**CAUTION:** Many repairs may only be done by a certified service technician. You should only perform troubleshooting and simple repairs as authorized in your product documentation, or as directed by the online or telephone service and support team. Damage due to servicing that is not authorized by Dell is not covered by your warranty. Read and follow the safety instructions that came with the product.

- 1 Place the SAS backplane board so that the securing tabs on the drive cage are fully inserted into the securing slots on the backplane board. See Figure 3-26.
- 2 Pull the SAS-backplane board release pin. See Figure 3-26.
- 3 While pulling the release pin, tilt the SAS-backplane board toward the front of the system until it stops, then release the release pin and ensure that it snaps into place.



- 4 Replace the fan bracket. See "Replacing the Fan Bracket" on page 82.
- 5 Replace the fans. See "Replacing a Cooling Fan" on page 79.
- 6 Replace the cooling shroud. See "Installing the Cooling Shroud" on page 81.
- 7 Reinstall the SAS controller daughter card. See "Installing a SAS Controller Daughter Card" on page 85.
- 8 Reattach the SAS controller daughter card cables and the control panel cable. See "SAS Controller Daughter Card Cabling Guidelines" on page 87.
- 9 Reinstall the hard drives. See "Installing a Hot-Plug Hard Drive" on page 70.  
 **NOTE:** Reinstall the hard drives in the same drive bays from which they were removed.
- 10 If applicable, reconnect the optical drive. See "Installing the Optical Drive" on page 97.
- 11 Close the system. See "Closing the System" on page 67.

# Control Panel Assembly (Service-only Procedure)

 **NOTE:** The control panel assembly consists of two separate modules—the display module and the control panel circuit board. Use the following instructions to remove and install either module.

## Removing the Control Panel Assembly

 **CAUTION:** Many repairs may only be done by a certified service technician. You should only perform troubleshooting and simple repairs as authorized in your product documentation, or as directed by the online or telephone service and support team. Damage due to servicing that is not authorized by Dell is not covered by your warranty. Read and follow the safety instructions that came with the product.

- 1 If applicable, remove the bezel. See "Removing the Front Bezel" on page 65.
- 2 Turn off the system and attached peripherals, and disconnect the system from the electrical outlet and peripherals.
- 3 Open the system. See "Opening the System" on page 67.
- 4 Disconnect the control panel cable at back of the control panel board. See Figure 3-27.

 **NOTICE:** Do not pull on the cable to unseat the connector. Doing so can damage the cable.

- a Squeeze the metal tabs on the ends of the cable connector.
  - b Gently work the connector out of the socket.
- 5 Disconnect the display module cable from the control panel board. See Figure 3-27.
  - 6 Remove the three screws that secure the control panel board to the system chassis and remove the board. See Figure 3-27.
  - 7 Remove the display module:
    - a Insert the end of paper clip into the hole on the right side of the display module and gently pry off the label.
    - b Using a T10 Torx driver, remove the two screws that secure the display module to the system chassis.
    - c Remove the display module from the chassis cutout.

**Figure 3-27. Control Panel Removal**

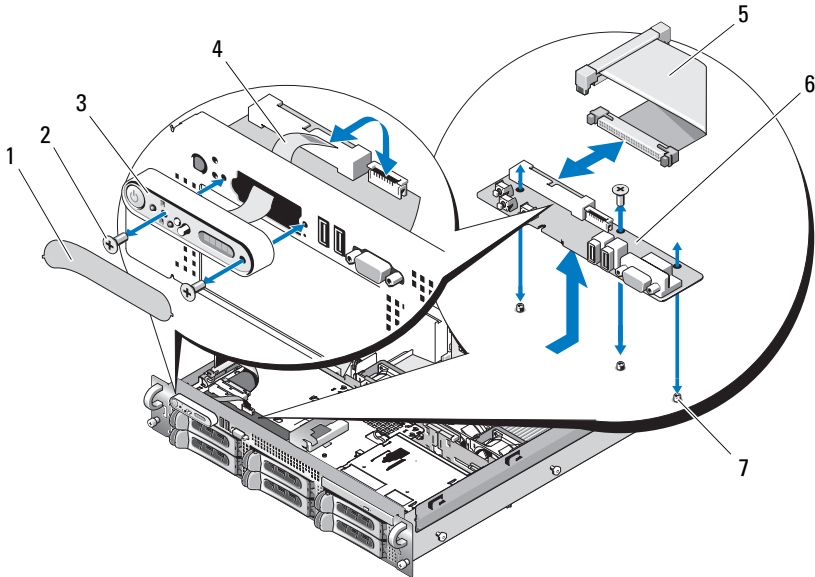

- |   |  |   |                                    |
|---|--|---|------------------------------------|
| 1 | display module label                               | 2 | display module securing screws (2) |
| 3 | display module                                     | 4 | display module cable               |
| 5 | control panel cable                                | 6 | control panel circuit board        |
| 7 | control-panel circuit board<br>securing screws (3) |   |                                    |

### **Installing the Control Panel Assembly**

- 1** Insert the display module into the chassis cutout and secure with the two Torx screws.
- 2** Affix the display module label to the display module.
- 3** Install the control panel board in the system chassis and secure with the three Phillips screws. See Figure 3-27.
- 4** Connect the display module cable to the control panel board. See Figure 3-27.

- 5 Connect the control panel cable to the control panel board. See Figure 3-27.
- 6 Close the system. See "Closing the System" on page 67.
- 7 Reconnect the system to the power source and turn on the system and attached peripherals.
- 8 If applicable, install the bezel.

## System Board (Service-only Procedure)

### Removing the System Board

 **CAUTION: Many repairs may only be done by a certified service technician. You should only perform troubleshooting and simple repairs as authorized in your product documentation, or as directed by the online or telephone service and support team. Damage due to servicing that is not authorized by Dell is not covered by your warranty. Read and follow the safety instructions that came with the product.**

- 1 Turn off the system and attached peripherals, and disconnect the system from the electrical outlet.
- 2 Open the system. See "Opening the System" on page 67
- 3 If applicable, remove any expansion cards. See "Installing an Expansion Card" on page 90
- 4 Remove the expansion-card cage. See "Removing the Expansion-Card Cage" on page 91
- 5 Remove the cooling shroud. See "Removing the Cooling Shroud" on page 80.
- 6 Remove the fans. See "Removing a System Fan" on page 78.
- 7 Remove the fan bracket. See "Removing the Fan Bracket" on page 81
- 8 If applicable, remove the DRAC card. See "DRAC Card and Cables" on page 93

 **CAUTION: The DIMMs are hot to the touch for some time after the system has been powered down. Allow time for the DIMMs to cool before handling them. Handle the DIMMs by the card edges and avoid touching the DIMM components.**

- 9 Remove the memory modules. See "Removing Memory Modules" on page 104.



**NOTE:** While removing the memory modules, record the memory module socket locations to ensure proper installation.

- 10** Remove the heatsink(s) and microprocessor(s). See "Removing a Processor" on page 105.
- 11** Remove the TOE key, if present. See Figure 6-2 for the location of the TOE key.
- 12** Remove the sideplane. See "Removing the Sideplane Board" on page 116.
- 13** Remove the SAS backplane. See "Removing the SAS Backplane Board" on page 118.
- 14** Remove the system board:
  - a** Pull the system-board tray riser release pin. See Figure 3-28.
  - b** While pulling the release pin, slide the system-board tray toward the front of the chassis.
  - c** Lift up the system-board tray and remove it from the chassis.

**Figure 3-28. System Board Removal**

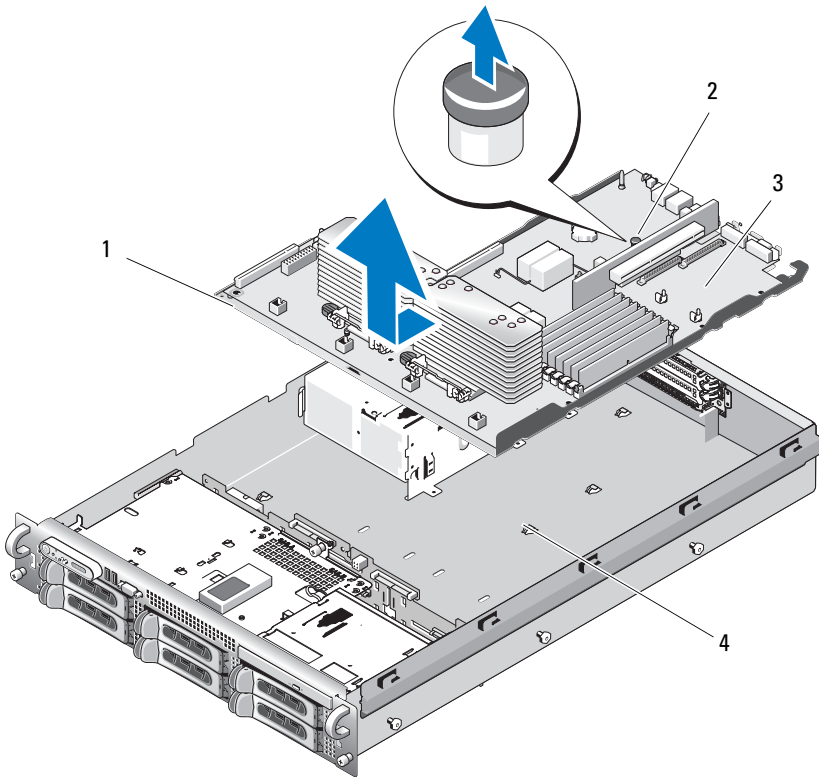

- |   |                   |   |                                     |
|---|-------------------|---|-------------------------------------|
| 1 | system-board tray | 2 | system-board tray riser release pin |
| 3 | system board      | 4 | system-board securing tabs          |

## Installing the System Board



**CAUTION:** Many repairs may only be done by a certified service technician. You should only perform troubleshooting and simple repairs as authorized in your product documentation, or as directed by the online or telephone service and support team. Damage due to servicing that is not authorized by Dell is not covered by your warranty. Read and follow the safety instructions that came with the product.

- 1 Lower the system-board tray until the tray sits flat on the bottom of the chassis.
- 2 Ensure that all 17 system-board securing tabs are fully inserted into the 17 system-board securing slots. See Figure 3-28.
- 3 Slide the system-board tray toward the back of the chassis until it locks into position.
- 4 Replace the SAS backplane. See "Installing the SAS Backplane Board" on page 120.
- 5 Replace the sideplane. See "Installing the Sideplane Board" on page 118
- 6 Reinstall the TOE key, if applicable. See Figure 6-2 for the TOE key's location.
- 7 Replace the heatsink(s) and microprocessor(s). See "Installing a Processor" on page 108.
- 8 Replace the memory modules. See "Installing Memory Modules" on page 102.
- 9 If applicable, replace the DRAC card. See "DRAC Card and Cables" on page 93.
- 10 Replace the fan bracket. See "Replacing the Fan Bracket" on page 82.
- 11 Replace the fans. See "Replacing a Cooling Fan" on page 79.
- 12 Replace the cooling shroud. See "Installing the Cooling Shroud" on page 81.
- 13 Replace the expansion-card cage. See "Replacing the Expansion-Card Cage" on page 93.
- 14 If applicable, replace any expansion cards. See "Installing an Expansion Card" on page 88.
- 15 Close the system. See "Closing the System" on page 67.





# Troubleshooting Your System

## Safety First—For You and Your System

To perform certain procedures in this document, you must remove the system cover and work inside the system. While working inside the system, do not attempt to service the system except as explained in this guide and elsewhere in your system documentation.



**CAUTION:** Many repairs may only be done by a certified service technician. You should only perform troubleshooting and simple repairs as authorized in your product documentation, or as directed by the online or telephone service and support team. Damage due to servicing that is not authorized by Dell is not covered by your warranty. Read and follow the safety instructions that came with the product.

## Start-Up Routine

Look and listen during the system's start-up routine for the indications described in Table 1-1.

**Table 4-1. Start-Up Routine Indications**

Look/listen for:	Action
A status or error message displayed on the front-panel LCD.	See "LCD Status Messages" on page 20.
An error message displayed on the monitor.	See "System Messages" on page 32.
Alert messages from the systems management software.	See the systems management software documentation.
The monitor's power indicator.	See "Troubleshooting the Video Subsystem" on page 131.
The keyboard indicators.	See "Troubleshooting the Keyboard" on page 132.
The USB CD drive activity indicator.	See "Troubleshooting a USB Device" on page 134.

**Table 4-1. Start-Up Routine Indications (continued)**

<b>Look/listen for:</b>	<b>Action</b>
The CD drive activity indicator.	See "Troubleshooting an Optical Drive" on page 143.
The hard-drive activity indicator.	See "Troubleshooting a Hard Drive" on page 146.
An unfamiliar constant scraping or grinding sound when you access a drive.	See "Getting Help" on page 167.

## Checking the Equipment

This section provides troubleshooting procedures for external devices attached to the system, such as the monitor, keyboard, or mouse. Before you perform any of the procedures, see "Troubleshooting External Connections" on page 131.

### Troubleshooting IRQ Assignment Conflicts

Most PCI devices can share an IRQ with another device, but they cannot use an IRQ simultaneously. To avoid this type of conflict, see the documentation for each PCI device for specific IRQ requirements. Table 4-2 lists the IRQ assignments.

**Table 4-2. IRQ Assignment Defaults**

<b>IRQ Line</b>	<b>Assignment</b>
IRQ0	System timer
IRQ1	Keyboard controller
IRQ2	Interrupt controller 1 to enable IRQ8 through IRQ15
IRQ3	Serial port 2 (COM2 and COM4)
IRQ4	Serial port 1 (COM1 and COM3)
IRQ5	Remote access controller
IRQ6	Diskette drive controller
IRQ7	Reserved
IRQ8	Real-time clock

**Table 4-2. IRQ Assignment Defaults (continued)**

<b>IRQ Line</b>	<b>Assignment</b>
IRQ9	ACPI functions (used for power management)
IRQ10	Available
IRQ11	Available
IRQ12	PS/2 mouse port unless the mouse is disabled through the System Setup program
IRQ13	Math coprocessor
IRQ14	IDE CD drive controller
IRQ15	Available

## **Troubleshooting External Connections**

Loose or improperly connected cables are the most likely source of problems for the system, monitor, and other peripherals (such as a printer, keyboard, mouse, or other external device). Ensure that all external cables are securely attached to the external connectors on your system. See "Front-Panel Features and Indicators" on page 13 and "Back-Panel Features and Indicators" on page 17 for the front- and back-panel connectors on your system.

## **Troubleshooting the Video Subsystem**

### ***Problem***

- Monitor is not working properly.
- Video memory is faulty.

### ***Action***

- 1** Check the system and power connections to the monitor.
- 2** Determine whether the system has an expansion card with a video output connector.

In this system configuration, the monitor cable should normally be connected to the connector on the expansion card, *not* to the system's integrated video connector.

To verify that the monitor is connected to the correct video connector, turn off the system and wait for 1 minute, then connect the monitor to the other video connector and turn the system on again.

- 3** Determine whether the system has monitors attached to both the front and rear video connectors.

The system supports only one monitor attached to either the front or rear video connector. When a monitor is connected to the front panel, the back-panel video, and PS/2 keyboard and mouse connectors are disabled.

If two monitors are attached to the system, disconnect one monitor. If the problem is not resolved, continue to the next step.

- 4** Run the appropriate online diagnostic test. See "Using Server Administrator Diagnostics" on page 153.

If the tests run successfully, the problem is not related to video hardware.

If the tests fail, see "Getting Help" on page 167.

## **Troubleshooting the Keyboard**

### ***Problem***

- System message indicates a problem with the keyboard
- Keyboard is not functioning properly

### ***Action***

- 1** Enter the System Setup program and ensure that the USB ports are enabled. See "Using the System Setup Program" on page 45.
- 2** Examine the keyboard and its cable for signs of damage.
- 3** Swap the faulty keyboard with a working keyboard.

If the problem is resolved, replace the faulty keyboard. See "Getting Help" on page 167.

- 4** Run the appropriate online diagnostic test. See "Using Server Administrator Diagnostics" on page 153.

If the problem is not resolved, see "Getting Help" on page 167.

## Troubleshooting the Mouse

### *Problem*

- System message indicates a problem with the mouse.
- Mouse is not functioning properly.

### *Action*

- 1** Run the appropriate online diagnostic test. See "Using Server Administrator Diagnostics" on page 153.  
If the test fails, continue to the next step.
- 2** Examine the mouse and its cable for signs of damage.  
If the mouse is not damaged, go to step 4.  
If the mouse is damaged, continue to the next step.
- 3** Swap the faulty mouse with a working mouse.  
If the problem is resolved, replace the faulty mouse. See "Getting Help" on page 167.
- 4** Enter the System Setup program and ensure that the USB port is enabled. See "Using the System Setup Program" on page 45.  
If the problem is not resolved, see "Getting Help" on page 167.

## Troubleshooting Basic I/O Functions

### *Problem*

- Error message indicates a problem with a serial port.
- Device connected to a serial port is not operating properly.

### *Action*

- 1** Enter the System Setup program and ensure that the serial port is enabled, and the serial port/COM ports are configured appropriately for any applications you are using. See "Using the System Setup Program" on page 45.

- 2 If the problem is confined to a particular application, see the application documentation for specific port configuration requirements that the program may require.
- 3 Run the appropriate online diagnostic test. See "Using Server Administrator Diagnostics" on page 153.

If the tests run successfully but the problem persists, see "Troubleshooting a Serial I/O Device" on page 134.

## **Troubleshooting a Serial I/O Device**

### ***Problem***

- Device connected to the serial port is not operating properly.

### ***Action***

- 1 Turn off the system and any peripheral devices connected to the serial port.
- 2 Swap the serial interface cable with a working cable, and turn on the system and the serial device.

If the problem is resolved, replace the interface cable.

- 3 Turn off the system and the serial device, and swap the device with a comparable device.
- 4 Turn on the system and the serial device.

If the problem is resolved, replace the serial device. See "Getting Help" on page 167.

If the problem persists, see "Getting Help" on page 167.

## **Troubleshooting a USB Device**

### ***Problem***

- System message indicates a problem with a USB device.
- Device connected to a USB port is not operating properly.

### **Action**

- 1** Enter the System Setup program, and ensure that the USB ports are enabled. See "Using the System Setup Program" on page 45.
- 2** Turn off the system and any USB devices.
- 3** Disconnect the USB devices, and connect the malfunctioning device to the other USB connector.
- 4** Turn on the system and the reconnected device.  
If the problem is resolved, the USB connector might be defective. See "Getting Help" on page 167.
- 5** If possible, swap the interface cable with a working cable.  
If the problem is resolved, replace the interface cable. See "Getting Help" on page 167.
- 6** Turn off the system and the USB device, and swap the device with a comparable device.
- 7** Turn on the system and the USB device.  
If the problem is resolved, replace the USB device. See "Getting Help" on page 167.  
If the problem persists, see "Getting Help" on page 167.

# Troubleshooting a NIC

## ***Problem***

- NIC cannot communicate with network.

## ***Action***

- 1** Run the appropriate online diagnostic test. See "Running the System Diagnostics" on page 154.
- 2** Check the appropriate indicator on the NIC connector. See "NIC Indicator Codes" on page 19.
  - If the link indicator does not light, check all cable connections.
  - If the activity indicator does not light, the network driver files might be damaged or missing.  
Remove and reinstall the drivers if applicable. See the NIC's documentation.
  - Change the autonegotiation setting, if possible.
  - Use another connector on the switch or hub.

If you are using a NIC card instead of an integrated NIC, see the documentation for the NIC card.

- 3** Ensure that the appropriate drivers are installed and the protocols are bound. See the NIC's documentation.
- 4** Enter the System Setup program and confirm that the NICs are enabled. See "Using the System Setup Program" on page 45.
- 5** Ensure that the NICs, hubs, and switches on the network are all set to the same data transmission speed. See the network equipment documentation.
- 6** Ensure that all network cables are of the proper type and do not exceed the maximum length. See Network Cable Requirements in your *Getting Started Guide*.



# Troubleshooting a Wet System

## *Problem*

- Liquid spilled on the system.
- Excessive humidity.

## *Action*



**CAUTION: Many repairs may only be done by a certified service technician. You should only perform troubleshooting and simple repairs as authorized in your product documentation, or as directed by the online or telephone service and support team. Damage due to servicing that is not authorized by Dell is not covered by your warranty. Read and follow the safety instructions that came with the product.**

- 1 Turn off the system and attached peripherals, and disconnect the system from the electrical outlet.
- 2 Open the system. See "Opening and Closing the System" on page 66.
- 3 Remove all expansion cards installed in the system. See "Removing an Expansion Card" on page 90.
- 4 Let the system dry thoroughly for at least 24 hours.
- 5 Close the system. See "Opening and Closing the System" on page 66.
- 6 Reconnect the system to the electrical outlet, and turn on the system and attached peripherals.

If the system does not start properly, see "Getting Help" on page 167.

- 7 If the system starts properly, shut down the system and reinstall all of the expansion cards that you removed. See "Installing an Expansion Card" on page 88.
- 8 Run the appropriate online diagnostic test. See "Using Server Administrator Diagnostics" on page 153.

If the tests fail, see "Getting Help" on page 167.

# Troubleshooting a Damaged System

## *Problem*

- System was dropped or damaged.

## *Action*



**CAUTION: Many repairs may only be done by a certified service technician. You should only perform troubleshooting and simple repairs as authorized in your product documentation, or as directed by the online or telephone service and support team. Damage due to servicing that is not authorized by Dell is not covered by your warranty. Read and follow the safety instructions that came with the product.**

- 1 Open the system. See "Opening and Closing the System" on page 66.
- 2 Ensure that the following components are properly installed:
  - Expansion cards and risers
  - Power supplies
  - Fans
  - Processors and heat sinks
  - Memory modules
  - Drive-carrier connections to the SAS backplane board, if applicable
- 3 Ensure that all cables are properly connected.
- 4 Close the system. See "Opening and Closing the System" on page 66.
- 5 Run the system board tests in the system diagnostics. See "Running the System Diagnostics" on page 154.  
If the tests fail, see "Getting Help" on page 167.

# Troubleshooting the System Battery

## *Problem*

- System message indicates a problem with the battery.
- System Setup program loses system configuration information.
- System date and time do not remain current.



**NOTE:** If the system is turned off for long periods of time (for weeks or months), the NVRAM may lose its system configuration information. This situation is caused by a defective battery.

### **Action**

- 1 Re-enter the time and date through the System Setup program. See "Using the System Setup Program" on page 45.
- 2 Turn off the system and disconnect it from the electrical outlet for at least one hour.
- 3 Reconnect the system to the electrical outlet and turn on the system.
- 4 Enter the System Setup program.

If the date and time are not correct in the System Setup program, replace the battery. See "System Battery" on page 110.

If the problem is not resolved by replacing the battery, see "Getting Help" on page 167.



**NOTE:** Some software may cause the system time to speed up or slow down. If the system seems to operate normally except for the time kept in the System Setup program, the problem may be caused by software rather than by a defective battery.

## **Troubleshooting Power Supplies**

### **Problem**

- System-status indicators are amber.
- Power-supply fault indicators are amber.
- Front-panel status LCD indicates a problem with the power supplies.

### **Action**



**CAUTION:** Many repairs may only be done by a certified service technician. You should only perform troubleshooting and simple repairs as authorized in your product documentation, or as directed by the online or telephone service and support team. Damage due to servicing that is not authorized by Dell is not covered by your warranty. Read and follow the safety instructions that came with the product.

1 Run the appropriate online diagnostics test. See "Using Server Administrator Diagnostics" on page 153.

2 Locate the faulty power supply.

The power supply's fault indicator is lit. See "Power Indicator Codes" on page 18.



**NOTICE:** You can hot-plug the power supplies. One power supply must be installed for the system to operate. The system is in the redundant mode when two power supplies are installed. Remove and install only one power supply at a time in a system that is powered on. Operating the system for extended periods of time with only one power supply installed, without a power supply blank installed, can cause the system to overheat.

Remove the faulty power supply. See "Removing a Power Supply" on page 76.

3 Ensure that the power supply is properly installed by removing and reinstalling it. See "Replacing a Power Supply" on page 77.



**NOTE:** After installing a power supply, allow several seconds for the system to recognize the power supply and to determine if it is working properly. The power indicator turns green to signify that the power supply is functioning properly. See "Power Indicator Codes" on page 18.

4 Check the indicators to see if the problem is resolved. If not, remove the faulty power supply. See "Removing a Power Supply" on page 76.

5 Install a new power supply. See "Replacing a Power Supply" on page 77. If the problem persists, see "Getting Help" on page 167.

## Troubleshooting System Cooling Problems

### *Problem*

- Systems management software issues a fan-related error message.

### *Action*

Ensure that none of the following conditions exist:

- Ambient temperature is too high.
- External airflow is obstructed.

- Cables inside the system obstruct airflow.
- An individual cooling fan has failed. See "Troubleshooting a Fan" on page 141.

## Troubleshooting a Fan

### *Problem*

- System-status indicator is amber.
- Systems management software issues a fan-related error message.
- Front panel LCD indicates a problem with the fan.

### *Action*



**CAUTION: Many repairs may only be done by a certified service technician. You should only perform troubleshooting and simple repairs as authorized in your product documentation, or as directed by the online or telephone service and support team. Damage due to servicing that is not authorized by Dell is not covered by your warranty. Read and follow the safety instructions that came with the product.**

- 1 Run the appropriate diagnostic test. See "Using Server Administrator Diagnostics" on page 153.
- 2 Open the system. See "Opening and Closing the System" on page 66.



**CAUTION: The cooling fans are hot-pluggable. To maintain proper cooling while the system is on, only replace one fan at a time.**

- 3 Locate the faulty fan indicated by the LCD display or diagnostic software. For the identification number of each fan, see Figure 3-8.
- 4 Ensure that the faulty fan's power cable is firmly attached to the fan power connector. See "System Fans" on page 78.



**NOTE:** Wait 30 seconds for the system to recognize the fan and determine whether it is working properly.

- 5 If the problem is not resolved, install a new fan. See "System Fans" on page 78.

If the replacement fan is working properly, close the system. See "Opening and Closing the System" on page 66.

If the replacement fan does not operate, see "Getting Help" on page 167.

# Troubleshooting System Memory

## **Problem**

- Faulty memory module.
- Faulty system board.
- Front-panel status LCD indicates a problem with system memory.

## **Action**



**CAUTION: Many repairs may only be done by a certified service technician. You should only perform troubleshooting and simple repairs as authorized in your product documentation, or as directed by the online or telephone service and support team. Damage due to servicing that is not authorized by Dell is not covered by your warranty. Read and follow the safety instructions that came with the product.**

- 1 Run the appropriate online diagnostic test. See "Using Server Administrator Diagnostics" on page 153.
- 2 Turn on the system and attached peripherals.  
If an error message does not appear, continue to the next step.  
If an error messages appears, go to step 11.
- 3 Enter the System Setup program and check the system memory setting. See "Entering the System Setup Program" on page 45.  
If the amount of memory installed matches the system memory setting, go to step 11.
- 4 Remove the bezel. See "Front Bezel" on page 65.
- 5 Turn off the system and attached peripherals, and disconnect the system from the electrical outlet.
- 6 Open the system. See "Opening and Closing the System" on page 66.
- 7 Reseat the memory modules in their sockets. See "Installing Memory Modules" on page 102.
- 8 Close the system. See "Opening and Closing the System" on page 66.
- 9 Reconnect the system to its electrical outlet, and turn on the system and attached peripherals.

- 10 Enter the System Setup program and check the system memory setting. See "Using the System Setup Program" on page 45.

If the amount of memory installed does not match the system memory setting, then perform the following steps:

- a Turn off the system and attached peripherals, and disconnect the system from its electrical outlet.
- b Open the system. See "Opening and Closing the System" on page 66.



**NOTE:** Several configurations for memory modules exist; see "General Memory Module Installation Guidelines" on page 100.

- c Swap the memory module in socket 1 with another of the same capacity. See "Installing Memory Modules" on page 102.
- d Close the system. See "Opening and Closing the System" on page 66.
- e Reconnect the system to its electrical outlet, and turn on the system and attached peripherals.
- f As the system boots, observe the monitor screen and the indicators on the keyboard.

- 11 Perform the following steps:

- a Turn off the system and attached peripherals, and disconnect the system from its electrical outlet.
- b Open the system. See "Opening and Closing the System" on page 66.
- c Perform step c through step f in step 10 for each memory module installed.

If the problem persists, see "Getting Help" on page 167.

## Troubleshooting an Optical Drive

### *Problem*

- System cannot read data from a CD or DVD in an optical drive.
- Optical drive indicator does not blink during boot.

### **Action**



**CAUTION: Many repairs may only be done by a certified service technician. You should only perform troubleshooting and simple repairs as authorized in your product documentation, or as directed by the online or telephone service and support team. Damage due to servicing that is not authorized by Dell is not covered by your warranty. Read and follow the safety instructions that came with the product.**

- 1 Try using a different CD or DVD that you know works properly.
- 2 Enter the System Setup program and ensure that the drive's IDE controller is enabled. See "Using the System Setup Program" on page 45.
- 3 Run the appropriate online diagnostic test. See "Using Server Administrator Diagnostics" on page 153.
- 4 Turn off the system and attached peripherals, and disconnect the system from the electrical outlet.
- 5 Open the system. See "Opening and Closing the System" on page 66.
- 6 Ensure that the interface cable is securely connected to the optical drive and to the sideplane.
- 7 Ensure that a power cable is properly connected to the drive.
- 8 Close the system. See "Opening and Closing the System" on page 66.
- 9 Reconnect the system to the electrical outlet, and turn on the system and attached peripherals.

If the problem is not resolved, see "Getting Help" on page 167.

## **Troubleshooting an External SCSI Tape Drive**

### **Problem**

- Defective tape drive
- Defective tape cartridge
- Missing or corrupted tape-backup software or tape drive device driver
- Defective SCSI controller



### **Action**

- 1 Remove the tape cartridge you were using when the problem occurred, and replace it with a tape cartridge that you know works.
- 2 Ensure that the SCSI device drivers for the tape drive are installed and are configured correctly.
- 3 Reinstall the tape-backup software as instructed in the tape-backup software documentation.
- 4 Ensure that the tape drive's interface/DC power cable is connected to the tape drive and SCSI controller card.
- 5 Verify that the tape drive is configured for a unique SCSI ID number and that the tape drive is terminated or not terminated, based on the interface cable used to connect the drive.

See the documentation for the tape drive for instructions on selecting the SCSI ID number and enabling or disabling termination.

- 6 Run the appropriate online diagnostics tests. See "Using Server Administrator Diagnostics" on page 153.
- 7 Open or remove the bezel. See "Front Bezel" on page 65.
- 8 Turn off the system and attached peripherals, and disconnect the system from the electrical outlet.



**CAUTION: Many repairs may only be done by a certified service technician. You should only perform troubleshooting and simple repairs as authorized in your product documentation, or as directed by the online or telephone service and support team. Damage due to servicing that is not authorized by Dell is not covered by your warranty. Read and follow the safety instructions that came with the product.**

- 9 Open the system. See "Opening and Closing the System" on page 66.
- 10 Ensure that the SCSI controller card is firmly seated in its connector. See "Installing an Expansion Card" on page 88.
- 11 Close the system. See "Opening and Closing the System" on page 66.
- 12 Reconnect the system to the electrical outlet, and turn on the system, including attached peripherals.
- 13 If the problem is not resolved, see the documentation for the tape drive for additional troubleshooting instructions.

- 14 If you cannot resolve the problem, see "Getting Help" on page 167 for information on obtaining technical assistance.

## Troubleshooting a Hard Drive

### *Problem*

- Device driver error.
- One or more hard drives not recognized by the system.

### *Action*



**CAUTION:** Many repairs may only be done by a certified service technician. You should only perform troubleshooting and simple repairs as authorized in your product documentation, or as directed by the online or telephone service and support team. Damage due to servicing that is not authorized by Dell is not covered by your warranty. Read and follow the safety instructions that came with the product.



**NOTICE:** This troubleshooting procedure can destroy data stored on the hard drive. Before you proceed, back up all files on the hard drive.

- 1 Run the appropriate online diagnostics test. See "Using Server Administrator Diagnostics" on page 153.

Depending on the results of the diagnostics test, proceed as needed through the following steps.

- 2 Remove the bezel. See "Removing the Front Bezel" on page 65.
- 3 If you are experiencing problems with multiple hard drives, skip to step 7. For a problem with a single hard drive, continue to the next step.
- 4 Turn off your system, reseal the hard drive, and restart the system.
- 5 If your system has a SAS controller daughter card, perform the following steps.
  - a Restart the system and press <Ctrl><C> to enter the host adapter configuration utility program.  
See the documentation supplied with the host adapter for information about the configuration utility.
  - b Ensure that the hard drive has been configured correctly for the RAID.



**support team. Damage due to servicing that is not authorized by Dell is not covered by your warranty. Read and follow the safety instructions that came with the product.**

- 1** Run the appropriate online diagnostic test. See "Using Server Administrator Diagnostics" on page 153.
- 2** Enter the System Setup program and ensure that the SAS controller daughter card is enabled. See "Using the System Setup Program" on page 45.
- 3** Restart the system and press the following key sequence to enter the configuration utility program:
  - <Ctrl><C> for a SAS controllerSee the controller's documentation for information about configuration settings.
- 4** Check the configuration settings, make any necessary corrections, and restart the system.

If the problem is not resolved, continue to the next step.
- 5** Remove the bezel. See "Removing the Front Bezel" on page 65.
- 6** Turn off the system and attached peripherals, and disconnect the system from its electrical outlet.
- 7** Open the system. See "Opening and Closing the System" on page 66.
- 8** Ensure that the controller card is firmly seated in its connector. See "SAS Controller Daughter Card" on page 85.
- 9** Verify that the cable connections between the SAS backplane(s) and the SAS controller daughter card are correct. See "Installing a SAS Controller Daughter Card" on page 85.
- 10** Ensure that the cables are firmly connected to the SAS controller daughter card and the SAS backplane board.
- 11** Close the system. See "Opening and Closing the System" on page 66.
- 12** Reconnect the system to its electrical outlet, and turn on the system and attached peripherals. If the problem persists, see "Getting Help" on page 167.

# Troubleshooting Expansion Cards



**NOTE:** When troubleshooting an expansion card, see the documentation for your operating system and the expansion card.

## *Problem*

- Error message indicates a problem with an expansion card.
- Expansion card performs incorrectly or not at all.

## *Action*



**CAUTION:** Many repairs may only be done by a certified service technician. You should only perform troubleshooting and simple repairs as authorized in your product documentation, or as directed by the online or telephone service and support team. Damage due to servicing that is not authorized by Dell is not covered by your warranty. Read and follow the safety instructions that came with the product.

- 1 Run the appropriate online diagnostic test. See "Using the System Setup Program" on page 45.
- 2 Open or remove the bezel. See "Front Bezel" on page 65.
- 3 Turn off the system and attached peripherals, and disconnect the system from the electrical outlet.
- 4 Open the system. See "Opening and Closing the System" on page 66.
- 5 Ensure that each expansion card is firmly seated in its connector. See "Installing an Expansion Card" on page 88.
- 6 Close the system. See "Opening and Closing the System" on page 66.
- 7 Reconnect the system to the electrical outlet, and turn on the system and attached peripherals.  
If the problem persists, go to the next step.
- 8 Turn off the system and attached peripherals, and disconnect the system from the electrical outlet.
- 9 Open the system. See "Opening and Closing the System" on page 66.
- 10 Remove all expansion cards installed in the system. See "Removing an Expansion Card" on page 90.
- 11 Close the system. See "Opening and Closing the System" on page 66.

- 12 Reconnect the system to the electrical outlet, and turn on the system and attached peripherals.
- 13 Run the appropriate online diagnostic test.  
If the tests fail, see "Getting Help" on page 167.
- 14 For each expansion card you removed in step 10, perform the following steps:
  - a Turn off the system and attached peripherals, and disconnect the system from the electrical outlet.
  - b Open the system. See "Opening and Closing the System" on page 66.
  - c Reinstall one of the expansion cards.
  - d Close the system. See "Opening and Closing the System" on page 66.
  - e Run the appropriate diagnostic test.  
If the tests fail, see "Getting Help" on page 167.

## Troubleshooting the Microprocessors

### *Problem*

- Error message indicates a processor problem.
- Front-panel status LCD indicates a problem with the processors or system board.
- A heat sink is not installed for each processor.

### *Action*



**CAUTION: Many repairs may only be done by a certified service technician. You should only perform troubleshooting and simple repairs as authorized in your product documentation, or as directed by the online or telephone service and support team. Damage due to servicing that is not authorized by Dell is not covered by your warranty. Read and follow the safety instructions that came with the product.**

- 1 Run the appropriate online diagnostics test. See "Using Server Administrator Diagnostics" on page 153.
- 2 Turn off the system and attached peripherals, and disconnect the system from the electrical outlet.

- 3** Open the system. See "Opening and Closing the System" on page 66.
- 4** Ensure that each processor and heat sink are properly installed. See "Processors" on page 105.
- 5** Close the system. See "Opening and Closing the System" on page 66.
- 6** Reconnect the system to the electrical outlet, and turn on the system and attached peripherals.
- 7** Run the appropriate online diagnostic test.  
If the tests fail or the problem persists, continue to the next step.
- 8** Turn off the system and attached peripherals, and disconnect the system from the electrical outlet.
- 9** Open the system. See "Opening and Closing the System" on page 66.
- 10** Remove processor 2, leaving only processor 1 installed. See "Processors" on page 105.  
To locate the processors, see Figure 6-2.  
If only one processor is installed, see "Getting Help" on page 167.
- 11** Close the system. See "Opening and Closing the System" on page 66.
- 12** Reconnect the system to the electrical outlet, and turn on the system and attached peripherals.
- 13** Run the appropriate online diagnostic test.  
If the tests complete successfully, go to step 19.
- 14** Turn off the system and attached peripherals, and disconnect the system from the electrical outlet.
- 15** Open the system. See "Opening and Closing the System" on page 66.
- 16** Replace processor 1 with another processor of the same capacity. See "Processors" on page 105.
- 17** Close the system. See "Opening and Closing the System" on page 66.
- 18** Run the appropriate online diagnostic test.  
If the tests complete successfully, replace processor 1. See "Getting Help" on page 167.
- 19** Turn off the system and attached peripherals, and disconnect the system from the electrical outlet.

- 20** Open the system. See "Opening and Closing the System" on page 66.
- 21** Reinstall the processors that you removed in step 10. See "Processors" on page 105.
- 22** Close the system. See "Opening and Closing the System" on page 66.
- 23** Reconnect the system to the electrical outlet, and turn on the system and attached peripherals.

If the problem persists, see "Getting Help" on page 167.



# Running the System Diagnostics

If you experience a problem with your system, run the diagnostics before calling for technical assistance. The purpose of the diagnostics is to test your system's hardware without requiring additional equipment or risking data loss. If you are unable to fix the problem yourself, service and support personnel can use diagnostics test results to help you solve the problem.

## Using Server Administrator Diagnostics

To assess a system problem, first use the online Server Administrator diagnostics. If you are unable to identify the problem, then use the system diagnostics.

To access the online diagnostics, log into the Server Administrator home page, and then click the **Diagnostics** tab. For information about using diagnostics, see the online help. For additional information, see the *Server Administrator User's Guide*.

## System Diagnostics Features

The system diagnostics provides a series of menus and options for particular device groups or devices. The system diagnostics menus and options allow you to:

- Run tests individually or collectively.
- Control the sequence of tests.
- Repeat tests.
- Display, print, or save test results.
- Temporarily suspend testing if an error is detected or terminate testing when a user-defined error limit is reached.
- View help messages that briefly describe each test and its parameters.
- View status messages that inform you if tests are completed successfully.
- View error messages that inform you of problems encountered during testing.

# When to Use the System Diagnostics

If a major component or device in the system does not operate properly, component failure may be indicated. As long as the microprocessor and the system's input/output devices (monitor, keyboard, and optical drive) are functioning, you can use the system diagnostics to help identify the problem.

## Running the System Diagnostics

The system diagnostics is run from the utility partition on your hard drive.

 **NOTICE:** Use the system diagnostics to test only your system. Using this program with other systems may cause invalid results or error messages. In addition, use only the program that came with your system (or an updated version of that program).

- 1 As the system boots, press <F10> during POST.
- 2 From the utility partition main menu, select **Run System Diagnostics**, or select **Run Memory Diagnostics** if you are troubleshooting memory.

When you start the system diagnostics, a message is displayed stating that the diagnostics are initializing. Next, the **Diagnostics** menu appears. The menu allows you to run all or specific diagnostics tests or to exit the system diagnostics.

 **NOTE:** Before you read the rest of this section, start the system diagnostics so that you can see the utility on your screen.

## System Diagnostics Testing Options

Click the testing option in the **Main Menu** window. Table 5-1 provides a brief explanation of testing options.

**Table 5-1. System Diagnostics Testing Options**

Testing Option	Function
Express Test	Performs a quick check of the system. This option runs device tests that do not require user interaction. Use this option to quickly identify the source of your problem.
Extended Test	Performs a more thorough check of the system. This test can take an hour or longer.
Custom Test	Tests a particular device.
Information	Displays test results.

# Using the Custom Test Options

When you select **Custom Test** in the **Main Menu** window, the **Customize** window appears and allows you to select the device(s) to be tested, select specific options for testing, and view the test results.

## Selecting Devices for Testing

The left side of the **Customize** window lists devices that can be tested. Devices are grouped by device type or by module, depending on the option you select. Click the (+) next to a device or module to view its components. Click (+) on any component to view the tests that are available. Clicking a device, rather than its components, selects all of the components of the device for testing.

## Selecting Diagnostics Options

Use the **Diagnostics Options** area to select how you want to test a device. You can set the following options:

- **Non-Interactive Tests Only** — When checked, runs only tests that require no user intervention.
- **Quick Tests Only** — When checked, runs only the quick tests on the device. Extended tests will not run when you select this option.
- **Show Ending Timestamp** — When checked, time stamps the test log.
- **Test Iterations** — Selects the number of times the test is run.
- **Log output file pathname** — When checked, enables you to specify where the test log file is saved.

## Viewing Information and Results

The tabs in the **Customize** window provide information about the test and the test results. The following tabs are available:

- **Results** — Displays the test that ran and the result.
- **Errors** — Displays any errors that occurred during the test.
- **Help** — Displays information about the currently selected device, component, or test.
- **Configuration** — Displays basic configuration information about the currently selected device.
- **Parameters** — If applicable, displays parameters that you can set for the test.

# Jumpers and Connectors

This section provides specific information about the system jumpers and describes the connectors on the various boards in the system.

## System Board Jumpers

Figure 6-1 shows the location of the configuration jumpers on the system board. Table 6-1 lists the jumper settings.







-  **NOTE:** To access the jumpers, remove the cooling shroud by lifting the release latch and sliding the shroud towards the front of the system. See Figure 3-9.
-  **NOTE:** Lift up the memory module airflow shroud for easy access to the jumpers.

Figure 6-1. System Board Jumpers

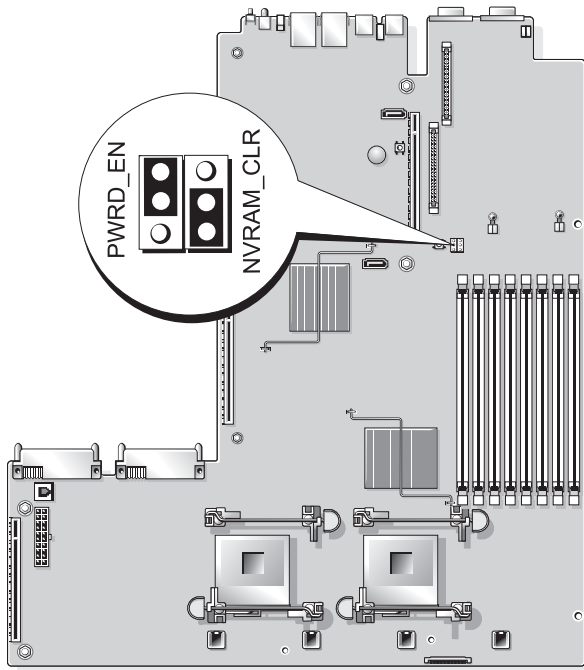

**Table 6-1. System Board Jumper Settings**

Jumper	Setting	Description
1 PWRD_EN	 (default)	The password feature is enabled.
		The password feature is disabled.
2 NVRAM_CLR	 (default)	The configuration settings are retained at system boot.
		The configuration settings are cleared at the next system boot. (If the configuration settings become corrupted to the point where the system will not boot, install the jumper and boot the system. Remove the jumper before restoring the configuration information.)

**NOTE:** For the full name of an abbreviation or acronym used in this table, see the "Glossary" on page 169.

## System Board Connectors

See Figure 6-2 and Table 6-2 for the location and description of system board connectors.

**Figure 6-2. System Board Connectors**

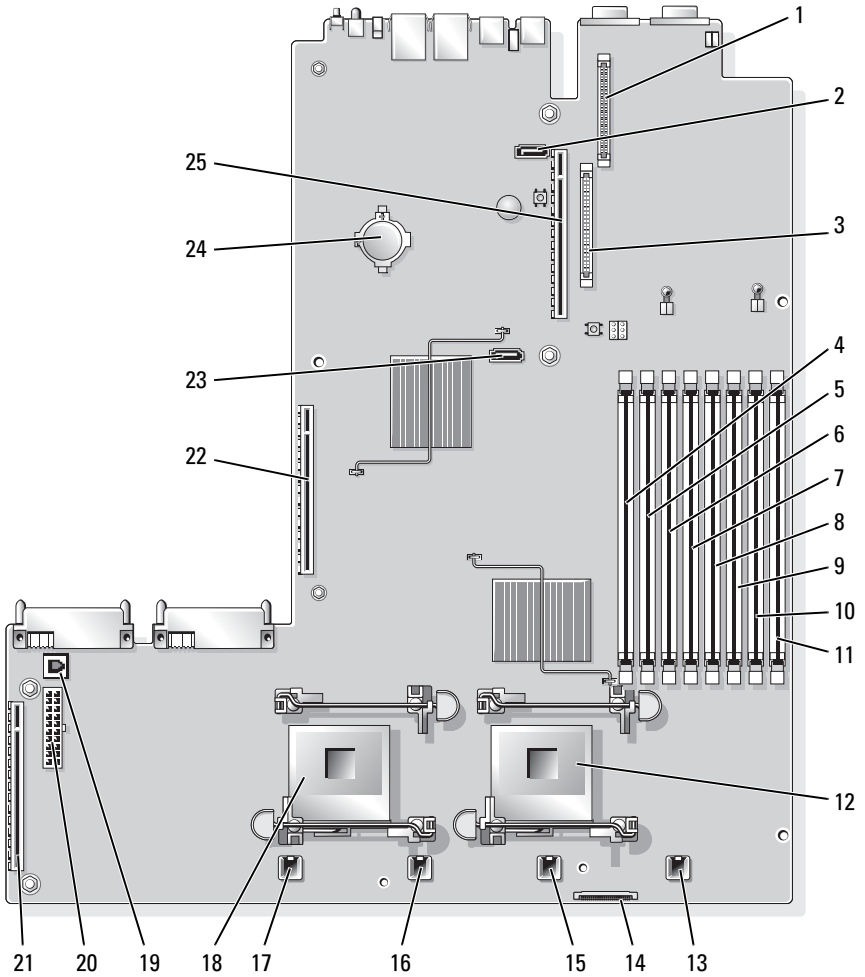

**Table 6-2. System Board Connectors**

Connector	Description
1	DRAC_CONN2 Dell Remote Access Control (DRAC) card 2
2	SATA_B SATA B connector

**Table 6-2. System Board Connectors (continued)**

<b>Connector</b>	<b>Description</b>
3 DRAC_CONN1	Dell Remote Access Control (DRAC) card 1
4 DIMM 1	Memory module, slot 1
5 DIMM 5	Memory module, slot 5
6 DIMM 2	Memory module, slot 2
7 DIMM 6	Memory module, slot 6
8 DIMM 3	Memory module, slot 3
9 DIMM 7	Memory module, slot 7
10 DIMM 4	Memory module, slot 4
11 DIMM 8	Memory module, slot 8
12 CPU1	Microprocessor 1
13 FAN4_2U	System cooling fan
14 FLOPPY	Floppy drive connector
15 FAN3_2U	System cooling fan
16 FAN2_2U	System cooling fan
17 FAN1_2U	System cooling fan
18 CPU2	Microprocessor 2
19 TOE_KEY	TCP/IP Offload Engine Key
20 BACKPLANE	Backplane power connector
21 SIDEPLANE	Sideplane connector
22 RISER1	Left riser board connector
23 SATA_A	SATA A connector
24 BATTERY	System battery
25 RISER2	Central riser board connector



# SAS Backplane Board Connectors

Figure 6-3 shows the location of the connectors on the SAS backplane board.

**Figure 6-3. SAS Backplane Board Components: 3.5-inch x4**

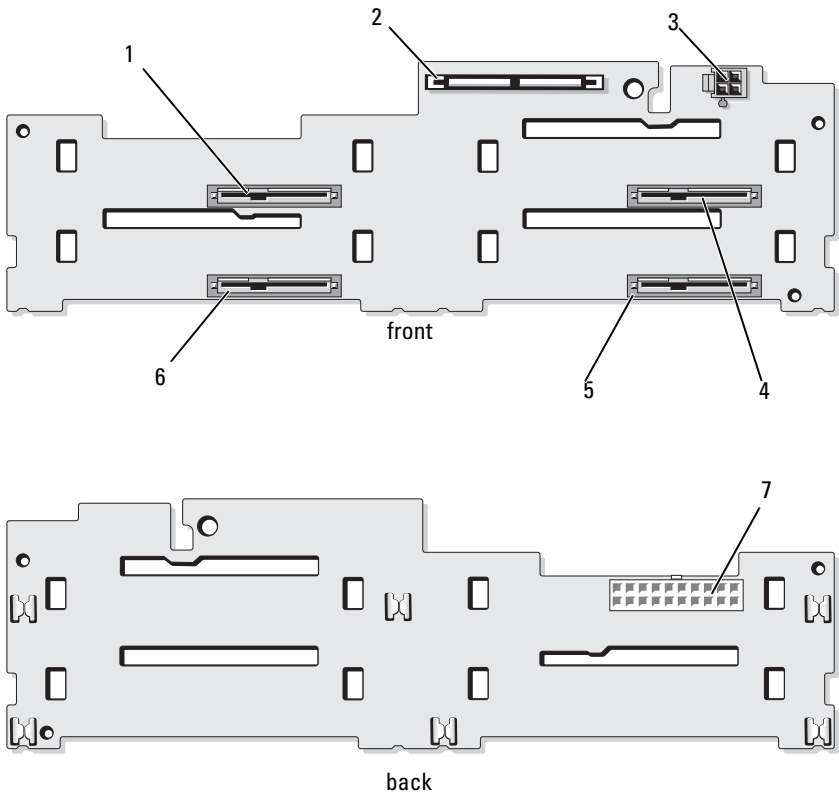

- |   |  |   |                   |
|---|--|---|-------------------|
| 1 | drive 0 (SASDRV0)                      | 2 | SAS (SAS_A)       |
| 3 | tape drive power connector (J_TBU_PWR) | 4 | drive 2 (SASDRV2) |
| 5 | drive 3 (SASDRV3)                      | 6 | drive 1 (SASDRV1) |
| 7 | backplane power (J_BP_PWR)             |   |                   |

# Sideplane Board Connectors

See Figure 6-4 for the location and description of connectors on the sideplane board.

**Figure 6-4. Sideplane Board Connectors**

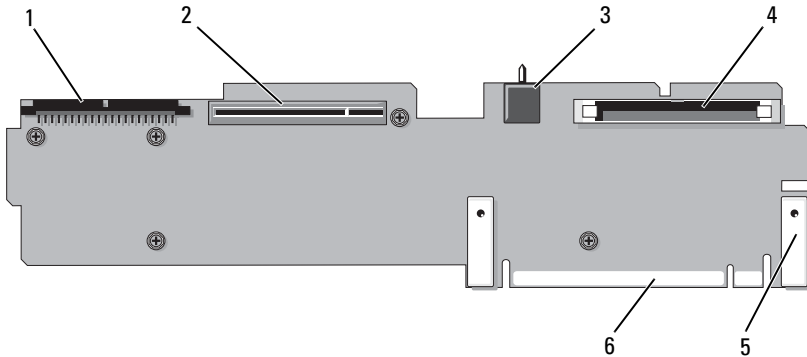

- |                            |   |
|----------------------------|---|
| 1 control panel (CTRL)     | 2 SAS controller daughter card (PCIE_STORAGE) |
| 3 chassis intrusion switch | 4 CD IDE (IDE)                                |
| 5 pin guides (2)           | 6 system board connector                      |

## Expansion-Card Riser-Board Components and PCI Buses

Figure 6-5 and Figure 6-6 show the components on the optional PCIe expansion-card riser boards, including the expansion-card slots and buses.

**Figure 6-5. Optional PCIe Left Expansion-Card Riser Board Components**

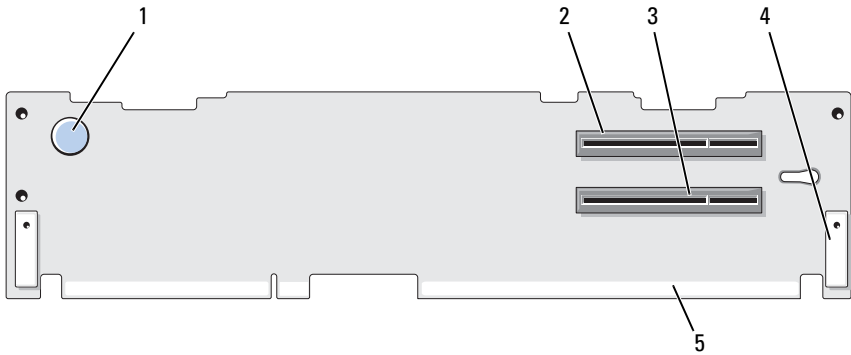

- |                             |                             |
|-----------------------------|-----------------------------|
| 1 riser release pin         | 2 slot 2 PCIe x8 lane width |
| 3 slot 3 PCIe x4 lane width | 4 pin guide (2)             |
| 5 system board connector    |                             |

**Figure 6-6. Optional PCIe Expansion-Card Central Riser Board Components**

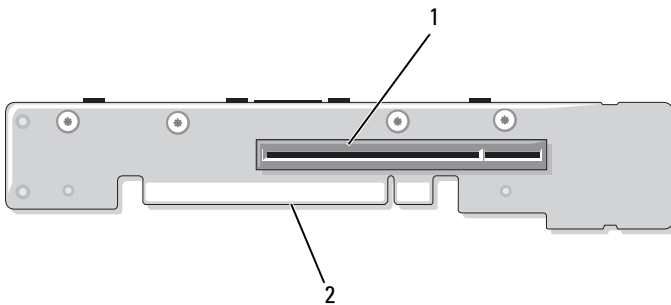

- |                                |                          |
|--------------------------------|--------------------------|
| 1 slot 1 PCI-X - x8 lane width | 2 system board connector |
|--------------------------------|--------------------------|

## Disabling a Forgotten Password

The system's software security features include a system password and a setup password, which are discussed in detail in "Using the System Setup Program" on page 45. The password jumper enables these password features or disables them and clears any password(s) currently in use.



**NOTICE:** See "Protecting Against Electrostatic Discharge" in the safety instructions that came with your system.

- 1 Turn off the system, including any attached peripherals, and disconnect the system from the electrical outlet.
- 2 Open the system. See "Opening and Closing the System" on page 66.
- 3 Lift up the memory module shroud.
- 4 Remove the jumper plug from the password jumper.  
See Figure 6-1 to locate the password jumper (labeled "PWRD\_EN") on the system board.
- 5 Close the system.
- 6 Reconnect your system and peripherals to their electrical outlets, and turn on the system.

The existing passwords are not disabled (erased) until the system boots with the password jumper plug removed. However, before you assign a new system and/or setup password, you must install the jumper plug.



**NOTE:** If you assign a new system and/or setup password with the jumper plug still removed, the system disables the new password(s) the next time it boots.

- 7 Turn off the system, including any attached peripherals, and disconnect the system from the electrical outlet.
- 8 Open the system. See "Opening and Closing the System" on page 66.
- 9 Install the jumper plug on the password jumper.
- 10 Lower the memory module shroud.
- 11 Close the system.

- 12** Reconnect your system and peripherals to their electrical outlets, and turn on the system.
- 13** Assign a new system and/or setup password.  
To assign a new password using the System Setup program, see "Assigning a System Password" on page 57.



# Getting Help

## Contacting Dell

For customers in the United States, call 800-WWW-DELL (800-999-3355).



**NOTE:** If you do not have an active Internet connection, you can find contact information on your purchase invoice, packing slip, bill, or Dell product catalog.

Dell provides several online and telephone-based support and service options. Availability varies by country and product, and some services may not be available in your area. To contact Dell for sales, technical support, or customer service issues:

- 1 Visit [support.dell.com](http://support.dell.com).
- 2 Verify your country or region in the **Choose A Country/Region** drop-down menu at the bottom of the page.
- 3 Click **Contact Us** on the left side of the page.
- 4 Select the appropriate service or support link based on your need.
- 5 Choose the method of contacting Dell that is convenient for you.





# Glossary

This section defines or identifies technical terms, abbreviations, and acronyms used in your system documents.

**A** — Ampere(s).

**AC** — Alternating current.

**ACPI** — Advanced Configuration and Power Interface. A standard interface for enabling the operating system to direct configuration and power management.

**ambient temperature** — The temperature of the area or room where the system is located.

**ANSI** — American National Standards Institute. The primary organization for developing technology standards in the U.S.

**application** — Software designed to help you perform a specific task or series of tasks. Applications run from the operating system.

**ASCII** — American Standard Code for Information Interchange.

**asset tag** — An individual code assigned to a system, usually by an administrator, for security or tracking purposes.

**backup** — A copy of a program or data file. As a precaution, back up your system's hard drive on a regular basis. Before making a change to the configuration of your system, back up important start-up files from your operating system.

**backup battery** — A battery that maintains system configuration, date, and time information in a special section of memory when the system is turned off.

**beep code** — A diagnostic message in the form of a pattern of beeps from your system's speaker. For example, one beep, followed by a second beep, and then a burst of three beeps is beep code 1-1-3.

**BIOS** — Basic input/output system. Your system's BIOS contains programs stored on a flash memory chip. The BIOS controls the following:

- Communications between the processor and peripheral devices
- Miscellaneous functions, such as system messages

**bit** — The smallest unit of information interpreted by your system.

**blade** — A module that contains a processor, memory, and a hard drive. The modules are mounted into a chassis that includes power supplies and fans.

**BMC** — Baseboard management controller.

**boot routine** — A program that clears all memory, initializes devices, and loads the operating system when you start your system. Unless the operating system fails to respond, you can reboot (also called *warm boot*) your system by pressing <Ctrl><Alt><Del>. Otherwise, you must restart the system by pressing the reset button or by turning the system off and then back on.

**bootable diskette** — A diskette that is used to start your system if the system will not boot from the hard drive.

**BTU** — British thermal unit.

**bus** — An information pathway between the components of a system. Your system contains an expansion bus that allows the processor to communicate with controllers for the peripheral devices connected to the system. Your system also contains an address bus and a data bus for communications between the processor and RAM.

**C** — Celsius.

**cache** — A fast storage area that keeps a copy of data or instructions for quick data retrieval. When a program makes a request to a disk drive for data that is in the cache, the disk-cache utility can retrieve the data from RAM faster than from the disk drive.

**CD** — Compact disc. CD drives use optical technology to read data from CDs.

**cm** — Centimeter(s).

**cmos** — Complementary metal-oxide semiconductor.

**component** — As they relate to DMI, components include operating systems, computer systems, expansion cards, and peripherals that are compatible with DMI. Each component is made up of groups and attributes that are defined as relevant to that component.

**COM $n$**  — The device names for the serial ports on your system.

**control panel** — The part of the system that contains indicators and controls, such as the power button and power indicator.

**controller** — A chip that controls the transfer of data between the processor and memory or between the processor and a peripheral.

**conventional memory** — The first 640 KB of RAM. Conventional memory is found in all systems. Unless they are specially designed, MS-DOS<sup>®</sup> programs are limited to running in conventional memory.

**coprocessor** — A chip that relieves the system's processor of specific processing tasks. A math coprocessor, for example, handles numeric processing.

**CPU** — Central processing unit. See *processor*.

**DC** — Direct current.

**DDR** — Double-data rate. A technology in memory modules that potentially doubles the output.

**device driver** — A program that allows the operating system or some other program to interface correctly with a peripheral. Some device drivers—such as network drivers—must be loaded from the `config.sys` file or as memory-resident programs (usually, from the `autoexec.bat` file). Others must load when you start the program for which they were designed.

**DHCP** — Dynamic Host Configuration Protocol. A method of automatically assigning an IP address to a client system.

**diagnostics** — A comprehensive set of tests for your system.

**DIMM** — Dual in-line memory module. See also *memory module*.

**DIN** — *Deutsche Industrie Norm*.

**directory** — Directories help keep related files organized on a disk in a hierarchical, “inverted tree” structure. Each disk has a “root” directory. Additional directories that branch off the root directory are called *subdirectories*. Subdirectories may contain additional directories branching off them.

**DMA** — Direct memory access. A DMA channel allows certain types of data transfer between RAM and a device to bypass the processor.

**DMI** — Desktop Management Interface. DMI enables the management of your system’s software and hardware by collecting information about the system’s components, such as the operating system, memory, peripherals, expansion cards, and asset tag.

**DNS** — Domain Name System. A method of translating Internet domain names, such as `www.dell.com`, into IP addresses, such as 143.166.83.200.

**DRAC** — Dell Remote access controller.

**DRAM** — Dynamic random-access memory. A system’s RAM is usually made up entirely of DRAM chips.

**DVD** — Digital versatile disc.

**ECC** — Error checking and correction.

**EEPROM** — Electronically erasable programmable read-only memory.

**EMC** — Electromagnetic compatibility.

**EMI** — Electromagnetic interference.

**ERA** — Embedded remote access. ERA allows you to perform remote, or “out-of-band,” server management on your network server using a remote access controller.

**ESD** — Electrostatic discharge.

**ESM** — Embedded server management.

**expansion bus** — Your system contains an expansion bus that allows the processor to communicate with controllers for peripherals, such as NICs.

**expansion card** — An add-in card, such as a NIC or SCSI adapter, that plugs into an expansion-card connector on the system board. An expansion card adds some specialized function to the system by providing an interface between the expansion bus and a peripheral.

**expansion-card connector** — A connector on the system board or riser board for plugging in an expansion card.

**F** — Fahrenheit.

**FAT** — File allocation table. The file system structure used by MS-DOS to organize and keep track of file storage. The Microsoft® Windows® operating systems can optionally use a FAT file system structure.

**flash memory** — A type of EEPROM chip that can be reprogrammed from a utility on diskette while still installed in a system; most EEPROM chips can only be rewritten with special programming equipment.

**format** — To prepare a hard drive or diskette for storing files. An unconditional format deletes all data stored on the disk.

**FSB** — Front-side bus. The FSB is the data path and physical interface between the processor and the main memory (RAM).

**ft** — Feet.

**FTP** — File transfer protocol.

**g** — Gram(s).

**G** — Gravities.

**Gb** — Gigabit(s); 1024 megabits or 1,073,741,824 bits.

**GB** — Gigabyte(s); 1024 megabytes or 1,073,741,824 bytes. However, when referring to hard-drive capacity, the term is usually rounded to 1,000,000,000 bytes.

**graphics mode** — A video mode that can be defined as  $x$  horizontal by  $y$  vertical pixels by  $z$  colors.

**group** — As it relates to DMI, a group is a data structure that defines common information, or attributes, about a manageable component.

**guarding** — A type of data redundancy in which a set of physical drives stores data and an additional drive stores parity data. See also *mirroring*, *striping*, and *RAID*.

**h** — Hexadecimal. A base-16 numbering system, often used in programming to identify addresses in the system's RAM and I/O memory addresses for devices. In text, hexadecimal numbers are often followed by *h*.

**headless system** — A system or device that functions without having a keyboard, mouse, or monitor attached. Normally, headless systems are managed over a network using an Internet browser.

**host adapter** — A host adapter implements communication between the system's bus and the controller for a peripheral device. (Hard-drive controller subsystems include integrated host adapter circuitry.) To add a SCSI expansion bus to your system, you must install or connect the appropriate host adapter.

**Hz** — Hertz.

**I/O** — Input/output. A keyboard is an input device, and a monitor is an output device. In general, I/O activity can be differentiated from computational activity.

**ID** — Identification.

**IDE** — Integrated drive electronics. A standard interface between the system board and storage devices.

**integrated mirroring** — Provides simultaneous physical mirroring of two drives. Integrated mirroring functionality is provided by the system's hardware. See also *mirroring*.

**internal processor cache** — An instruction and data cache built into the processor.

**IP** — Internet Protocol.

**IPX** — Internet package exchange.

**IRQ** — Interrupt request. A signal that data is about to be sent to or received by a peripheral device travels by an IRQ line to the processor. Each peripheral connection must be assigned an IRQ number. Two devices can share the same IRQ assignment, but you cannot operate both devices simultaneously.

**jumper** — Small blocks on a circuit board with two or more pins emerging from them. Plastic plugs containing a wire fit down over the pins. The wire connects the pins and creates a circuit, providing a simple and reversible method of changing the circuitry in a board.

**K** — Kilo-; 1000.

**Kb** — Kilobit(s); 1024 bits.

**KB** — Kilobyte(s); 1024 bytes.

**Kbps** — Kilobit(s) per second.

**KBps** — Kilobyte(s) per second.

**key combination** — A command requiring you to press multiple keys at the same time (for example, <Ctrl><Alt><Del>).

**kg** — Kilogram(s); 1000 grams.

**kHz** — Kiloherzt.

**KMM** — Keyboard/monitor/mouse.

**KVM** — Keyboard/video/mouse. KVM refers to a switch that allows selection of the system from which the video is displayed and for which the keyboard and mouse are used.

**LAN** — Local area network. A LAN is usually confined to the same building or a few nearby buildings, with all equipment linked by wiring dedicated specifically to the LAN.

**lb** — Pound(s).

**LCD** — Liquid crystal display.

**LED** — Light-emitting diode. An electronic device that lights up when a current is passed through it.

**Linux** — Like a UNIX<sup>®</sup> operating system that runs on a variety of hardware systems. Linux is open source software, which is freely available; however, the full distribution of Linux along with technical support and training are available for a fee from vendors such as Red Hat<sup>®</sup> Software.

**local bus** — On a system with local-bus expansion capability, certain peripheral devices (such as the video adapter circuitry) can be designed to run much faster than they would with a traditional expansion bus. See also *bus*.

**LVD** — Low voltage differential.

**m** — Meter(s).

**mA** — Milliampere(s).

**MAC address** — Media Access Control address. Your system's unique hardware number on a network.

**mAh** — Milliampere-hour(s).

**Mb** — Megabit(s); 1,048,576 bits.

**MB** — Megabyte(s); 1,048,576 bytes. However, when referring to hard-drive capacity, the term is often rounded to mean 1,000,000 bytes.

**Mbps** — Megabits per second.

**MBps** — Megabytes per second.

**MBR** — Master boot record.

**memory address** — A specific location, usually expressed as a hexadecimal number, in the system's RAM.

**memory module** — A small circuit board containing DRAM chips that connects to the system board.

**memory** — An area in your system that stores basic system data. A system can contain several different forms of memory, such as integrated memory (ROM and RAM) and add-in memory modules (DIMMs).

**MHz** — Megahertz.

**mirroring** — A type of data redundancy in which a set of physical drives stores data and one or more sets of additional drives stores duplicate copies of the data. Mirroring functionality is provided by software. See also *guarding*, *integrated mirroring*, *striping*, and *RAID*.

**mm** — Millimeter(s).

**ms** — Millisecond(s).

**MS-DOS®** — Microsoft Disk Operating System.

**NAS** — Network Attached Storage. NAS is one of the concepts used for implementing shared storage on a network. NAS systems have their own operating systems, integrated hardware, and software that are optimized to serve specific storage needs.

**NIC** — Network interface controller. A device that is installed or integrated in a system to allow connection to a network.

**NMI** — Nonmaskable interrupt. A device sends an NMI to signal the processor about hardware errors.

**ns** — Nanosecond(s).

**NTFS** — The NT File System option in the Windows 2000 operating system.

**NVRAM** — Nonvolatile random-access memory. Memory that does not lose its contents when you turn off your system. NVRAM is used for maintaining the date, time, and system configuration information.

**parity** — Redundant information that is associated with a block of data.

**partition** — You can divide a hard drive into multiple physical sections called *partitions* with the **fdisk** command. Each partition can contain multiple logical drives. You must format each logical drive with the **format** command.

**PCI** — Peripheral Component Interconnect. A standard for local-bus implementation.

**PDU** — Power distribution unit. A power source with multiple power outlets that provides electrical power to servers and storage systems in a rack.

**peripheral** — An internal or external device, such as a diskette drive or keyboard, connected to a system.

**PGA** — Pin grid array. A type of processor socket that allows you to remove the processor chip.

**pixel** — A single point on a video display. Pixels are arranged in rows and columns to create an image. A video resolution, such as 640 x 480, is expressed as the number of pixels across by the number of pixels up and down.

**POST** — Power-on self-test. Before the operating system loads when you turn on your system, the POST tests various system components such as RAM and hard drives.

**processor** — The primary computational chip inside the system that controls the interpretation and execution of arithmetic and logic functions. Software written for one processor must usually be revised to run on another processor. *CPU* is a synonym for processor.

**protected mode** — An operating mode that allows operating systems to implement:

- A memory address space of 16 MB to 4 GB
- Multitasking
- Virtual memory, a method for increasing addressable memory by using the hard drive

The Windows 2000 and UNIX 32-bit operating systems run in protected mode. MS-DOS cannot run in protected mode.

**PS/2** — Personal System/2.

**PXE** — Preboot eXecution Environment. A way of booting a system via a LAN (without a hard drive or bootable diskette).

**RAID** — Redundant array of independent disks. A method of providing data redundancy. Some common implementations of RAID include RAID 0, RAID 1, RAID 5, RAID 10, and RAID 50. See also *guarding*, *mirroring*, and *striping*.

**RAM** — Random-access memory. The system's primary temporary storage area for program instructions and data. Any information stored in RAM is lost when you turn off your system.

**RAS** — Remote Access Service. This service allows users running the Windows operating system to remotely access a network from their system using a modem.

**readme file** — A text file, usually shipped with software or hardware, that contains information supplementing or updating the product's documentation.

**read-only file** — A read-only file is one that you are prohibited from editing or deleting.

**ROM** — Read-only memory. Your system contains some programs essential to its operation in ROM code. A ROM chip retains its contents even after you turn off your system. Examples of code in ROM include the program that initiates your system's boot routine and the POST.

**ROMB** — RAID on motherboard.

**rpm** — Revolutions per minute.



**RTC** — Real-time clock.

**SAS** — Serial-attached SCSI.

**SATA** — Serial Advanced Technology Attachment. A standard interface between the system board and storage devices.

**SCSI** — Small computer system interface. An I/O bus interface with faster data transmission rates than standard ports.

**SDRAM** — Synchronous dynamic random-access memory.

**sec** — Second(s).

**serial port** — An I/O port used most often to connect a modem to your system. You can usually identify a serial port on your system by its 9-pin connector.

**service tag** — A bar code label on the system used to identify it when you call Dell for technical support.

**simple disk volume** — The volume of free space on a single dynamic, physical disk.

**SMART** — Self-Monitoring Analysis and Reporting Technology. Allows hard drives to report errors and failures to the system BIOS and then display an error message on the screen.

**SMP** — Symmetric multiprocessing. Used to describe a system that has two or more processors connected via a high-bandwidth link and managed by an operating system, where each processor has equal access to I/O devices.

**SNMP** — Simple Network Management Protocol. A standard interface that allows a network manager to remotely monitor and manage workstations.

**spanning** — Spanning, or concatenating, disk volumes combines unallocated space from multiple disks into one logical volume, allowing more efficient use of all the space and all drive letters on a multiple-disk system.

**striping** — Disk striping writes data across three or more disks in an array, but only uses a portion of the space on each disk. The amount of space used by a "stripe" is the same on each disk used. A virtual disk may use several stripes on the same set of disks in an array. See also *guarding*, *mirroring*, and *RAID*.

**SVGA** — Super video graphics array. VGA and SVGA are video standards for video adapters with greater resolution and color display capabilities than previous standards.

**system board** — As the main circuit board, the system board usually contains most of your system's integral components, such as the processor, RAM, controllers for peripherals, and various ROM chips.

**system configuration information** — Data stored in memory that tells a system what hardware is installed and how the system should be configured for operation.

**system diskette** — See *bootable diskette*.

**system memory** — See RAM.

**System Setup program** — A BIOS-based program that allows you to configure your system's hardware and customize the system's operation by setting features such as password protection. Because the System Setup program is stored in NVRAM, any settings remain in effect until you change them again.

**system.ini file** — A start-up file for the Windows operating system. When you start Windows, it consults the **system.ini** file to determine a variety of options for the Windows operating environment. Among other things, the **system.ini** file records which video, mouse, and keyboard drivers are installed for Windows.

**TCP/IP** — Transmission Control Protocol/Internet Protocol.

**termination** — Some devices (such as the last device at each end of a SCSI cable) must be terminated to prevent reflections and spurious signals in the cable. When such devices are connected in a series, you may need to enable or disable the termination on these devices by changing jumper or switch settings on the devices or by changing settings in the configuration software for the devices.

**TOE** — TCP/IP offload engine.

**UNIX** — Universal Internet Exchange. UNIX, the precursor to Linux, is an operating system written in the C programming language.

**uplink port** — A port on a network hub or switch used to connect to other hubs or switches without requiring a crossover cable.

**UPS** — Uninterruptible power supply. A battery-powered unit that automatically supplies power to your system in the event of an electrical failure.

**USB** — Universal Serial Bus. A USB connector provides a single connection point for multiple USB-compliant devices, such as mice and keyboards. USB devices can be connected and disconnected while the system is running.

**utility** — A program used to manage system resources—memory, disk drives, or printers, for example.

**UTP** — Unshielded twisted pair. A type of wiring used to connect systems in a business or home to a telephone line.

**V** — Volt(s).

**VAC** — Volt(s) alternating current.

**VDC** — Volt(s) direct current.

**VGA** — Video graphics array. VGA and SVGA are video standards for video adapters with greater resolution and color display capabilities than previous standards.

**video adapter** — The logical circuitry that provides (in combination with the monitor) your system's video capabilities. A video adapter may be integrated into the system board or may be an expansion card that plugs into an expansion slot.

**video driver** — A program that allows graphics-mode application programs and operating systems to display at a chosen resolution with the desired number of colors. Video drivers may need to match the video adapter installed in the system.

**video memory** — Most VGA and SVGA video adapters include memory chips in addition to your system's RAM. The amount of video memory installed primarily influences the number of colors that a program can display (with the appropriate video drivers and monitor capabilities).

**video resolution** — Video resolution (800 x 600, for example) is expressed as the number of pixels across by the number of pixels up and down. To display a program at a specific graphics resolution, you must install the appropriate video drivers and your monitor must support the resolution.

**W** — Watt(s).

**WH** — Watt-hour(s).

**win.ini file** — A start-up file for the Windows operating system. When you start Windows, it consults the **win.ini** file to determine a variety of options for the Windows operating environment. The **win.ini** file also usually includes sections that contain optional settings for Windows application programs that are installed on the hard drive.

**Windows 2000** — An integrated and complete Microsoft Windows operating system that does not require MS-DOS and that provides advanced operating system performance, improved ease of use, enhanced workgroup functionality, and simplified file management and browsing.

**Windows Powered** — A Windows operating system designed for use on NAS systems. For NAS systems, the Windows Powered operating system is dedicated to file service for network clients.

**Windows Server 2003** — A set of Microsoft software technologies that enable software integration through the use of XML Web services. XML Web services are small reusable applications written in XML that allow data to be communicated between otherwise unconnected sources.

**XML** — Extensible Markup Language. XML is a way to create common information formats and to share both the format and the data on the World Wide Web, intranets, and elsewhere.

**ZIF** — Zero insertion force.



# Index

## A

alert messages, 44

## B

back-panel  
features, 17

baseboard management  
controller, 61  
BMC, 61

batteries  
removing and replacing, 110  
troubleshooting, 138

bezel  
removing, 65-66  
replacing, 66

blank  
hard drive, 69  
power supply, 78

BMC, 61

boot device  
configuring, 87

## C

cable retention bracket  
installing, 84  
removing, 83

cable routing, 83

cabling  
cable routing, 83

CD drive  
troubleshooting, 143

central riser board  
installing, 115  
removing, 114

checking equipment, 130

configuring  
memory, 100

connecting external devices, 18

connectors  
expansion-card riser board, 162  
SAS backplane board, 161  
system board, 158

contacting Dell, 167

control panel assembly  
installing, 123  
removing, 122

cooling fan  
troubleshooting, 141

cooling fans  
removing, 78  
replacing, 79

cover  
removing, 66

## D

- damaged systems
  - troubleshooting, 138
- daughter card
  - SAS, 85, 87
- Dell
  - contacting, 167
- diagnostics
  - advanced testing options, 155
  - testing options, 154
  - when to use, 154
- DRAC card
  - installing, 93
  - removing, 95
- drive blank
  - installing, 70
  - removing, 69
- drive carrier
  - SATA hard drive (SATA), 72
  - SATA hard drive (SATAu), 73

## E

- error messages, 45
- expansion cards
  - installation guidelines, 88
  - installing, 88
  - removing, 90
  - troubleshooting, 149
- expansion slots
  - PCI buses, 162
- expansion-card cage

- removing, 91
- replacing, 93

- expansion-card riser board
  - connectors, 162
  - PCI buses, 162
- external devices
  - connecting, 18

## F

- fan bracket
  - removing, 81
  - replacing, 82
- features
  - back-panel, 17
  - front-panel, 13

## G

- guidelines
  - expansion card installation, 88
- guidelines for memory
  - installation, 100

## H

- hard drive
  - installing, 70
  - installing SATA in a SATA drive carrier, 72
  - installing SATA in a SATAu drive carrier, 73
  - removing, 70

- removing from a drive carrier, 72
- troubleshooting, 146

## hard drives

- boot device, 87
- indicator codes, 15

## hot-plug

- hard drives, 70

## I

### indicators

- back-panel, 17
- front-panel, 13
- hard-drive, 15
- NIC, 19
- power, 18

### installing

- cable retention bracket, 84
- control panel assembly, 123
- DRAC card, 93
- expansion card, 88
- expansion card guidelines, 88
- hard drive blank, 70
- hard drives, 70
- left riser board, 112
- memory, 102
- memory guidelines, 100
- optical drive, 97
- optical drive cable, 99
- power supply blank, 78
- processor, 105, 108
- SAS backplane board, 120
- SAS controller daughter card, 85

- SATA hard drive in a SATA drive carrier, 72

- SATA hard drive in a SATAu drive carrier, 73

- sideplane board, 118
- system board, 127

## integrated NIC TOE

- activating, 105

## IRQs

- avoiding conflicts, 130
- line assignments, 130

## J

### jumpers

- system board, 157

## K

### keyboard

- troubleshooting, 132

## L

### left riser board

- installing, 113
- removing, 112

## M

### memory

- installation guidelines, 100
- installing, 102

- system, 100
- troubleshooting, 142
- memory modules
  - removing, 104
- messages
  - alert, 44
  - error messages, 45
  - hard-drive indicator codes, 15
  - status LCD, 20
  - system, 32
  - warning, 43
- microprocessors
  - troubleshooting, 150
- mouse
  - troubleshooting, 133

## **N**

- NICs
  - indicators, 19
  - troubleshooting, 136

## **O**

- optical drive
  - installing, 97
- optical drive and cable
  - removing, 96
- optical drive cable
  - installing, 99
  - removing, 99
- options

- system setup, 46

## **P**

- password
  - disabling, 164
- password features
  - setup, 56
  - system, 56
- passwords
  - setup, 59
  - system, 56
- PCI buses
  - expansion-card riser board, 162
- phone numbers, 167
- POST
  - accessing system features, 12
- power
  - indicator, 18
- power supplies
  - removing, 76
  - replacing, 77
  - troubleshooting, 139
- power supply blank, 78
- processor
  - removing, 105, 108
  - upgrades, 105

## **R**

- removing
  - bezel, 65



- cable retention bracket, 83
- central riser, 114-115
- control panel assembly, 122
- cooling fan, 78
- cover, 66
- DRAC card, 95
- expansion card, 90
- expansion-card cage, 91
- fan bracket, 81
- hard drive blank, 69
- hard drive from a drive carrier, 72
- hard drives, 70
- left riser, 113
- left riser board, 112
- memory, 104
- optical drive and cable, 96
- optical drive cable, 99
- power supply, 76
- power supply blank, 78
- processor, 105, 108
- SAS backplane board, 118
- SAS controller daughter card, 85, 87
- sideplane board, 116
- system battery, 110
- system board, 124

removing and replacing  
bezel, 66

replacing  
bezel, 66  
cooling fan, 79  
expansion-card cage, 93  
fan bracket, 82  
power supply, 77  
system battery, 110

system board, 124

## **S**

safety, 129

SAS backplane board

- connectors, 161

- installing, 120

- removing, 118

SAS controller daughter card

- cabling guidelines, 87

- installing, 85

- removing, 85, 87

- troubleshooting, 147

SATA Cable Routing in  
thePowerVault DL2000, 98

securing your system, 58

serial I/O device

- troubleshooting, 134

setup password

- assigning, 59

- changing, 60

- using, 59

setup password enabled

- working with, 60

setup password features, 56

sideplane board

- installing, 118

- removing, 116

startup

- accessing system features, 12

support

- contacting Dell, 167
- system
  - opening, 66
- system board
  - connectors, 158
  - installing, 127
  - jumpers, 157
  - removing, 124
  - replacing, 124
- system cooling
  - troubleshooting, 140
- system features
  - accessing, 12
- system messages, 32
- system password
  - assigning, 57
  - changing, 59
  - deleting, 59
  - using, 56
- system password features, 56
- system setup
  - entering, 45, 61
  - options, 46
  - using, 46
- system setup program
  - memory options, 49
- system setup screens
  - console redirection, 53
  - integrated devices, 51
  - main, 46
  - system security, 53

## T

- tape drive
  - troubleshooting, 144
- telephone numbers, 167
- TOE
  - activating integrated NIC
    - TOE, 105
- troubleshooting
  - basic I/O, 133
  - battery, 138
  - CD drive, 143
  - cooling fan, 141
  - damaged system, 138
  - expansion cards, 149
  - external connections, 131
  - hard drive, 146
  - keyboard, 132
  - memory, 142
  - microprocessors, 150
  - mouse, 133
  - NIC, 136
  - power supplies, 139
  - SAS controller daughtercard, 147
  - serial I/O device, 134
  - start-up routine, 129
  - system cooling, 140
  - tape drive, 144
  - USB device, 134
  - video, 131
  - wet system, 137

## U

- upgrades

- processor, 105
- USB device
  - troubleshooting, 134
- using system setup, 46

## **V**

- video
  - troubleshooting, 131

## **W**

- warning messages, 43
- warranty, 11
- wet system
  - troubleshooting, 137



## Free Manuals Download Website

<http://myh66.com>

<http://usermanuals.us>

<http://www.somanuals.com>

<http://www.4manuals.cc>

<http://www.manual-lib.com>

<http://www.404manual.com>

<http://www.luxmanual.com>

<http://aubethermostatmanual.com>

Golf course search by state

<http://golfingnear.com>

Email search by domain

<http://emailbydomain.com>

Auto manuals search

<http://auto.somanuals.com>

TV manuals search

<http://tv.somanuals.com>