

CHANNEL VISION™
10 Year Limited Warranty

Channel Vision Technology will repair or replace any defect in material or workmanship which occurs during normal use of this product with new or rebuilt parts, free of charge in the USA, for ten years from the date of original purchase. This is a no hassle warranty with no mail in warranty card needed. This warranty does not cover damages in shipment, failures caused by other products not supplied by Channel Vision Technology, or failures due to accident, misuse, abuse, or alteration of the equipment. This warranty is extended only to the original purchaser, and a purchase receipt, invoice, or other proof of original purchase date will be required before warranty repairs are provided.

Mail in service can be obtained during the warranty period by calling (800) 840-0288 toll free. A Return Authorization number must be obtained in advance and can be marked on the outside of the shipping carton.

This warranty gives you specific legal rights and you may have other rights (which vary from state to state). If a problem with this product develops during or after the warranty period, please contact Channel Vision Technology, your dealer or any factory-authorized service center.

CHANNEL VISION™
www.channelvision.com

234 Fischer Avenue, Costa Mesa, California 92626 USA
(714)424-6500 • (800)840-0288 • (714)424-6510 fax
email: techsupport@channelvision.com

500-027 rev D

Download from Www.Somanuals.com. All Manuals Search And Download.

INSTRUCTIONS



OS525 **5.25" Marine/Outdoor Speaker**

CHANNEL VISION™
©2008 CHANNEL VISION TECHNOLOGY

Model OS525

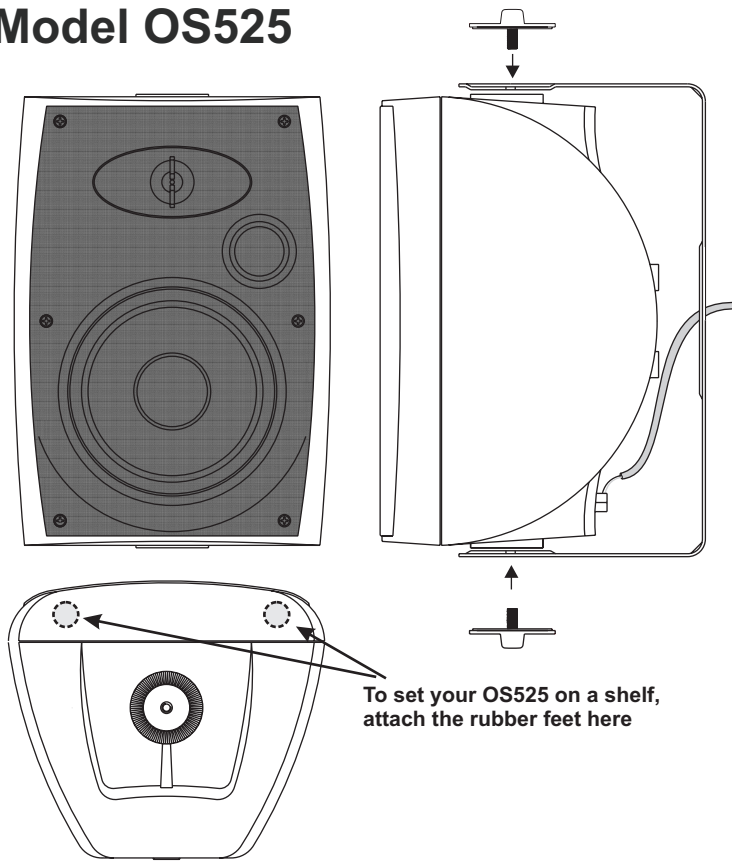

To set your OS525 on a shelf,
attach the rubber feet here

- 1) Weather resistant design
- 2) Aluminum grilles, and brackets
- 3) Stainless steel hardware
- 4) UV protected cabinet resists sun fade
- 5) 14 AWG gold plated terminal posts
- 6) 5.25" woofer with mica mix cone
- 7) 1" soft dome tweeter
- 8) 18dB /octave crossover network
- 9) Tweeter protected by poly switch

Specifications:

- Frequency range:** 45Hz - 20kHz \pm 3dB
- Sensitivity:** 89dB (1W/1M)
- Power Handling:** 100 Watts
- Drivers:** 1- 25mm soft dome tweeter
1- 5.25" woofer w/ 1" voice coil
- Impedance:** 6 ohms
- Finish:** ABS plastic
- Dimensions:** 11"H x 6 3/4" W x 7 1/2" D
- Weight:** 5.2 Lbs with bracket

Specifications subject to change without notice.

Installation:

- The OS525 may be mounted vertically or horizontally.
- The OS525's case is weather resistant and made with UV stabilized ABS. But for longest life, we recommend placement in a protected area, such as under an eave.
- We recommend wiring with AWG 16 or larger, stranded wire.
- For proper phasing, both speakers must be wired alike. Connect red wire to red terminal on speakers and to red or plus terminal on amplifier.
- To control the volume of the speakers locally, use an impedance matching volume control, such as the Channel Vision VC-302.

Free Manuals Download Website

<http://myh66.com>

<http://usermanuals.us>

<http://www.somanuals.com>

<http://www.4manuals.cc>

<http://www.manual-lib.com>

<http://www.404manual.com>

<http://www.luxmanual.com>

<http://aubethermostatmanual.com>

Golf course search by state

<http://golfingnear.com>

Email search by domain

<http://emailbydomain.com>

Auto manuals search

<http://auto.somanuals.com>

TV manuals search

<http://tv.somanuals.com>