



**19XL  
50/60 Hz  
Hermetic Centrifugal Liquid Chillers  
with HCFC-22 and HFC-134a**

## **Start-Up, Operation, and Maintenance Instructions**

---

Manufacturer reserves the right to discontinue, or change at any time, specifications or designs without notice and without incurring obligations.

PC 211

Catalog No. 531-94512-94

Form 19XL-3SS

Replaces: 19XL-2SS

Copyright © Carrier Corporation 1994

---

## **Safety Considerations**

**Centrifugal liquid chillers are designed to provide safe and reliable service when operated within design specifications. When operating this equipment, use good judgement and safety precautions to avoid damage to equipment and property or injury to personnel.**

**Be sure you understand and follow the procedures and safety precautions contained in the machine instructions as well as those listed in this guide.**



**DANGER**



**DANGER**

**DO NOT VENT** refrigerant relief devices within a building. Outlet from rupture disc or relief valve must be vented outdoors in accordance with the latest edition of ANSI/ASHRAE 15 (American National Standards Institute/American Society of Heating, Refrigeration, and Air Conditioning Engineers). The accumulation of refrigerant in an enclosed space can displace oxygen and cause asphyxiation.

**PROVIDE** adequate ventilation in accordance with ANSI/ASHRAE 15, especially for enclosed and low overhead spaces. Inhalation of high concentrations of vapor is harmful and may cause heart irregularities, unconsciousness, or death. Misuse can be fatal. Vapor is heavier than air and reduces the amount of oxygen available for breathing. Product causes eye and skin irritation. Decomposition products are hazardous.

**DO NOT USE OXYGEN** to purge lines or to pressurize a machine for any purpose. Oxygen gas reacts violently with oil, grease, and other common substances.

**NEVER EXCEED** specified test pressures. **VERIFY** the allowable test pressure by checking the instruction literature and the design pressures on the equipment nameplate.

**DO NOT USE** air for leak testing. Use only refrigerant or dry nitrogen.

**DO NOT VALVE OFF** any safety device.

**BE SURE** that all pressure relief devices are properly installed and functioning before operating any machine.



**WARNING**



**WARNING**

**DO NOT WELD OR FLAMECUT** any refrigerant line or vessel until all refrigerant (*liquid and vapor*) has been removed from chiller. Traces of vapor should be displaced with dry air or nitrogen and the work area should be well ventilated.

***Refrigerant in contact with an open flame produces toxic gases.***

**DO NOT USE** eyebolts or eyebolt holes to rig machine sections or the entire assembly.

**DO NOT** work on high-voltage equipment unless you are a qualified electrician.

**DO NOT WORK ON** electrical components, including control panels, switches, starters, or oil heater until you are sure **ALL POWER IS OFF** and no residual voltage can leak from capacitors or solid-state components.

**LOCK OPEN AND TAG** electrical circuits during servicing. **IF WORK IS INTERRUPTED**, confirm that all circuits are deenergized before resuming work.

**DO NOT** siphon refrigerant.

**AVOID SPILLING** liquid refrigerant on skin or getting it into the eyes. **USE SAFETY GOGGLES.** Wash any spills from the skin with soap and water. If liquid refrigerant enters the eyes, **IMMEDIATELY FLUSH EYES** with water and consult a physician.

**NEVER APPLY** an open flame or live steam to a refrigerant cylinder. Dangerous over pressure can result. When it is necessary to heat refrigerant, use only warm (110 F [43 C]) water.



**WARNING**



**WARNING**

**DO NOT REUSE disposable (nonreturnable) cylinders or attempt to refill them. It is DANGEROUS AND ILLEGAL. When cylinder is emptied, evacuate remaining gas pressure, loosen the collar, and unscrew and discard the valve stem. DO NOT INCINERATE.**

**CHECK THE REFRIGERANT TYPE before adding refrigerant to the machine. The introduction of the wrong refrigerant can cause machine damage or malfunction to this machine. Operation of this equipment with refrigerants other than those cited herein should comply with ANSI/ASHRAE-15 (latest edition). Contact Carrier for further information on use of this machine with other refrigerants.**

**DO NOT ATTEMPT TO REMOVE fittings, covers, etc., while machine is under pressure or while machine is running. Be sure pressure is at 0 psig (0 kPa) before breaking any refrigerant connection.**

**CAREFULLY INSPECT all relief devices, rupture discs, and other relief devices AT LEAST ONCE A YEAR. If machine operates in a corrosive atmosphere, inspect the devices at more frequent intervals.**

**DO NOT ATTEMPT TO REPAIR OR RECONDITION any relief device when corrosion or build-up of foreign material (rust, dirt, scale, etc.) is found within the valve body or mechanism. Replace the device.**

**DO NOT install relief devices in series or backwards.**

**USE CARE when working near or in line with a compressed spring. Sudden release of the spring can cause it and objects in its path to act as projectiles.**



**CAUTION**



**CAUTION**

**DO NOT STEP** on refrigerant lines. Broken lines can whip about and release refrigerant, causing personal injury.

**DO NOT** climb over a machine. Use platform, catwalk, or staging. Follow safe practices when using ladders.

**USE MECHANICAL EQUIPMENT** (crane, hoist, etc.) to lift or move inspection covers or other heavy components. Even if components are light, use mechanical equipment when there is a risk of slipping or losing your balance.

**BE AWARE** that certain automatic start arrangements **CAN ENGAGE THE STARTER, TOWER FAN, OR PUMPS**. Open the disconnect *ahead of* the starter, tower fan, and pumps.

**USE** only repair or replacement parts that meet the code requirements of the original equipment.

**DO NOT VENT OR DRAIN** waterboxes containing industrial brines, liquid, gases, or semisolids without the permission of your process control group.

**DO NOT LOOSEN** waterbox cover bolts until the waterbox has been completely drained.

**DOUBLE-CHECK** that coupling nut wrenches, dial indicators, or other items have been removed before rotating any shafts.

**DO NOT LOOSEN** a packing gland nut before checking that the nut has a positive thread engagement.



**CAUTION**



**CAUTION**

**PERIODICALLY INSPECT** all valves, fittings, and piping for corrosion, rust, leaks, or damage.

**PROVIDE A DRAIN** connection in the vent line near each pressure relief device to prevent a build-up of condensate or rain water.



**List of Tables**

**List of Figures**

**Safety Considerations**

**Introduction**

**Abbreviations and Explanations**

**Machine Familiarization**

**Machine Information Plate**

**System Components**

**Cooler**

**Condenser**

**Motor-Compressor**

**Control Center**

**Factory-Mounted Starter (Optional)**

**Storage Vessel (Optional)**

### **Refrigeration Cycle**

### **Motor/Oil Refrigeration Cooling Cycle**

### **Lubrication Cycle**

#### **Summary**

#### **Details**

#### **Oil Reclaim System**

##### **During Normal Machine Operation**

##### **During Light Load Conditions**

### **Starting Equipment**

#### **Unit Mounted Solid-State Starter (Optional)**

#### **Unit Mounted Wye-Delta Starter (Optional)**

### **Controls**

#### **Definitions**

##### **Analog Signal**



**Digital Signal**

**Volatile Memory**

**General**

**PIC System Components**

**Processor Module (PSIO)**

**Starter Management Module (SMM)**

**Local Interface Device (LID)**

**6-Pack Relay Board**

**8-Input Modules**

**Oil Heater Contactor (1C)**

**Oil Pump Contactor (2C)**

**Hot Gas Bypass Contactor Relay (3C) (Optional)**

**Control Transformers (T1-T4)**

**Control and Oil Heater Voltage Selector (S1)**

**LID Operation and Menus**

**General**

**Alarm and Alerts**

**Menu Structure**

**To View Point Status**

**Override Operations**

**Time Schedule Operation**

**To View and Change Set Points**

**Service Operation**

**PIC System Functions**

**Capacity Control**

**Entering Chilled Water Control**

**Deadband**

**Proportional Bands and Gain**

**Demand Limiting**

**Machine Timers**

**Occupancy Schedule**

**Safety Controls**

**Shunt Trip**

**Default Screen Freeze**

**Motor Cooling Control**

**Ramp Loading Control**

**Capacity Override**

**High Discharge Temperature Control**

**Oil Sump Temperature Control**

**PSIO Software Versions 08 and Lower**

**PSIO Software Versions 09 and Higher**

**Oil Cooler**

**Remote Start/Stop Controls**

**Spare Safety Inputs**

**Spare Alarm Contacts**

**Condenser Pump Control**

**Condenser Freeze Protection**

**Tower Fan Relay**

**Auto. Restart After Power Failure**

**Water/Brine Reset**

**Demand Limit Control, Option (Requires Optional 8-Input Module)**

**Surge Prevention Algorithm**

**Surge Protection**

**Lead/Lag Control**

**Common Point Sensor Installation**

**Machine Communication Wiring**

**Lead/Lag Operation**

**Faulted Chiller Operation**

**Load Balancing**

**Auto Restart After Power Failure**

**Ice Build Control**

**Ice Build Initiation**

---

## **Contents**

---

**Start-Up/Recycle Operation**

**Temperature Control During Ice Build**

**Termination of Ice Build**

**Return to Non-ice Build Operations**

**Attach to Network Device Control**

**Changing Refrigerant Types**

**Attaching to Other CCN Modules**

**Service Operation**

**To Log On**

**To Log Off**

**Holiday Scheduling**

**Start-Up/Shutdown/Recycle Sequence**

**Local Start-Up**

**Shutdown Sequence**

**Automatic Soft-Stop Amps Threshold (PSIO Software Version 09 and Higher)**

**Chilled Water Recycle Mode**

**Safety Shutdown**

**Before Initial Start-Up**

**Job Data Required**

**Equipment Required**

**Using the Optional Storage Tank and Pumpout System**

**Remove Shipping Packaging**

**Open Oil Circuit Valves**

**Torque All Gasketed Joints**

**Check Machine Tightness**

**Refrigerant Tracer**

**Leak Test Machine**

**Standing Vacuum Test**

**Machine Dehydration**

**Inspect Water Piping**

**Check Optional Pumpout Compressor Water Piping**

**Check Relief Devices**

**Inspect Wiring**

**Carrier Comfort Network Interface**

**Check Starter**

**Mechanical-Type Starters**

**Benshaw, Inc. Solid-State Starter**

**Cutler-Hammer® Solid-State Starters**

**Oil Charge**

**Power Up the Controls and Check the Oil Heater**

**Software Version**

**Set Up Machine Control Configuration**

**Input the Design Set Points**

**Input the Local Occupied Schedule (OCCPC01S)**

**Selecting Refrigerant Type**

**To Confirm Refrigerant Type**

**To Change Refrigerant Type**

**Input Service Configurations**

**Password**

**Input Time and Date**

**Change LID Configuration If Necessary**

**Modify Controller Identification If Necessary**

**Input Equipment Service Parameters If Necessary**

**Modify Equipment Configuration If Necessary**

**Check Voltage Supply**

**Perform an Automated Control Test**

**Check Optional Pumpout System Controls and Compressor**

**High Altitude Locations**



### **Charge Refrigerant into Machine**

**19XL Machine Equalization without Pumpout Unit**

**19XL Machine Equalization with Pumpout Unit**

**Trimming Refrigerant Charge**

### **Initial Start-Up**

**Preparation**

**Manual Operation of the Guide Vanes**

**Dry Run to Test Start-Up Sequence**

**Check Rotation**

**If Rotation Is Proper**

**If the Motor Rotation Is Not Clockwise**

**Notes on Solid-State Starters (Benshaw, Inc.)**

**Check Oil Pressure and Compressor Stop**

**Calibrate Motor Current Demand Setting**

**To Prevent Accidental Start-Up**

### **Check Machine Operating Condition**

#### **Instruct the Customer Operator**

**Cooler-Condenser**

**Optional Storage Tank and Pumpout System**

**Motor Compressor Assembly**

**Motor Compressor Lubrication System**

**Control System**

**Auxiliary Equipment**

**Describe Machine Cycles**

**Review Maintenance**

**Safety Devices and Procedures**

**Check Operator Knowledge**

**Review the Start-Up, Operation, and Maintenance Manual**

### **Operating Instructions**

#### **Operator Duties**

**Prepare the Machine for Start-Up**

**To Start the Machine**

**Check the Running System**

**To Stop the Machine**

**After Limited Shutdown**

**Extended Shutdown**

**After Extended Shutdown**

**Cold Weather Operation**

**Manual Guide Vane Operation**

**Refrigeration Log**

**Pumpout and Refrigerant Transfer Procedures**

**Preparation**

**Operating the Optional Pumpout Compressor**

**To Read Refrigerant Pressures**

### **Machines with Storage Tanks**

**Transfer Refrigerant from Storage Tank to Machine**

**Transfer the Refrigerant from Machine to Storage Tank**

### **Machines with Isolation Valves**

**Transfer All Refrigerant to Condenser Vessel**

**Transfer All Refrigerant to Cooler/Compressor Vessel**

**Return Refrigerant to Normal Operating Conditions**

### **General Maintenance**

**Refrigerant Properties**

**Adding Refrigerant**

**Removing Refrigerant**

**Adjusting the Refrigerant Charge**

**Refrigerant Leak Testing**

**Leak Rate**

**Test After Service, Repair, or Major Leak**

**Refrigerant Tracer**

**To Pressurize with Dry Nitrogen**

**Repair the Leak, Retest, and Apply Standing Vacuum Test**

**Checking Guide Vane Linkage**

**Checking the Auxiliary Switch on Guide Vane Actuator**

**Trim Refrigerant Charge**

**Weekly Maintenance**

**Check the Lubrication System**

**Scheduled Maintenance**

**Service Ontime**

**Inspect the Control Center**

**Check Safety and Operating Controls Monthly**

**Changing Oil Filter**

**Oil Specification**

**Oil Changes**

**To Change the Oil**

**Refrigerant Filter**

**Oil Reclaim Filters**

**Inspect Refrigerant Float System**

**Inspect Relief Valves and Piping**

**Compressor Bearing and Gear Maintenance**

**Inspect the Heat Exchanger Tubes**

**Cooler**

**Condenser**

**Water Leaks**

**Water Treatment**

**Inspect the Starting Equipment**

**Check Pressure Transducers**

**Optional Pumpout System Maintenance**

**Optional Pumpout Compressor Oil Charge**

**Optional Pumpout Safety Control Settings**

**Ordering Replacement Chiller Parts**

**Troubleshooting Guide**

**Overview**

**Checking the Display Messages**

**Checking Temperature Sensors**

**Resistance Check**

**Voltage Drop**

**Check Sensor Accuracy**

**Dual Temperature Sensors**

**Checking Pressure Transducers**

**Transducer Replacement**

**Control Algorithms Checkout Procedure**

**Control Test**

**Control Modules**

**Red LED**

**Green LEDs**

**Notes on Module Operation**

**Processor Module (PSIO)**

**Inputs**

**Outputs**

**Starter Management Module (SMM)**

**Inputs**

**Outputs**

**Options Modules (8-Input)**

**Replacing Defective Processor Modules**

**Installation**



### **Solid-State Starters**

**Testing Silicon Control Rectifiers in Benshaw, Inc. Solid-State Starters**

**Testing Silicon Control Rectifiers (SCRs) in Cutler-Hammer®  
Solid-State Starters**

**Electronic Protection Relay (EPR)**

### **Physical Data**

**Initial Start-Up Checklist for 19XL Hermetic Centrifugal Liquid Chiller**

## List of Tables

**Table 1 — Major PIC Components and Panel Locations**

**Table 2 — LID Screens**

**Example 1 — Status01 Display Screen**

**Example 2 — Status02 Display Screen**

**Example 3 — Status03 Display Screen**

**Example 4 — Setpoint Display Screen**

**Example 5 — Configuration (Config) Display Screen**

**Example 6 — Lead/Lag Configuration Display Screen**

**Example 7 — Service1 Display Screen**

**Example 8 — Service2 Display Screen**

**Example 9 — Service3 Display Screen**

**Example 10 — Maintenance (Maint01) Display Screen**

**Example 11 — Maintenance (Maint02) Display Screen**

**Example 12 — Maintenance (Maint03) Display Screen**

**Example 13 — Maintenance (Maint04) Display Screen**

---

## Contents

---

- Table 3 — Protective Safety Limits and Control Settings**
- Table 4 — Capacity Overrides**
- Table 5A — HCFC-22 Pressure — Temperature (F)**
- Table 5B — HCFC-22 Pressure — Temperature (C)**
- Table 5C — HFC-134a Pressure — Temperature (F)**
- Table 5D — HFC-134a Pressure — Temperature (C)**
- Table 6 — Potentiometer Adjustment**
- Table 7 — Amps Correction Factors for 19XL Motors**
- Table 8 — Control Test Menu Functions**
- Table 9 — Refrigerant (HCFC-22 or HFC-134a) Charges**
- Table 10 — LID Primary and Secondary Messages and Custom Alarm/  
Alert Messages with Troubleshooting Guides**
  - A. Shutdown with On/Off/Reset-Off**
  - B. Timing Out or Timed Out**
  - C. In Recycle Shutdown**

### **Table 10 — LID Primary and Secondary Messages and Custom Alarm/ Alert Messages with Troubleshooting Guides (Continued)**

**D. Pre-Start Alerts**

**E. Normal or Auto.-Restart**

**F. Start-Up Failures**

**G. Compressor Jumpstart and Refrigerant Protection**

**H. Normal Run with Reset, Temperature, or Demand**

**I. Normal Run Overrides Active (Alerts)**

**J. Out-Of-Range Sensor Failures**

**K. Machine Protect Limit Faults**

**L. Machine Alerts**

**M. Spare Sensor Alert Messages**

**N. Other Problems/Malfunctions**

**Table 11A— Thermistor Temperature (F) vs Resistance/Voltage Drop**

**Table 11B— Thermistor Temperature (C) vs Resistance/Voltage Drop**

**Table 12 — Benshaw, Inc. Solid-State Starter Troubleshooting Guide**

---

## Contents

---

**Table 13 — Cutler-Hammer® Solid-State Starter Troubleshooting Guide**

**Table 14 — Heat Exchanger Data**

**Table 15 — Additional Data for Marine Waterboxes**

**Table 16 — Compressor Weights**

**Table 17 — Compressor/Motor Weights**

**Table 18 — Waterbox Cover Weights**

**Table 19 — Optional Pumpout System Electrical Data**

### List of Figures

**Figure 1 — 19XL Identification**

**Figure 2A— Typical 19XL Components — Design I**

**Figure 2B— Typical 19XL Components — Design II**

**Figure 3 — Refrigerant Motor Cooling and Oil Cooling Cycles**

**Figure 4 — Lubrication System**

**Figure 5 — Cutler-Hammer Solid-State Starter, Internal View**

**Figure 6 — Benshaw, Inc. Solid-State Starter, Internal View**

**Figure 7 — Typical Starter Front View (Solid-State Starter Shown)**

**Figure 8 — 19XL Controls and Sensor Locations**

**Figure 9 — Control Sensors (Temperature)**

**Figure 10— Control Sensors (Pressure Transducer, Typical)**

**Figure 11— Control Panel (Front View), with Options Module**

**Figure 12— Power Panel with Options**

**Figure 13 — LID Default Screen**

**Figure 14 — LID Service Screen**

**Figure 15 — Example of Point Status Screen (Status01)**

**Figure 16 — 19XL Menu Structure**

**Figure 17 — 19XL Service Menu Structure**

**Figure 18 — Example of Time Schedule Operation Screen**

**Figure 19 — Example of Set Point Screen**

**Figure 20 — 19XL Hot Gas Bypass/Surge Prevention**

**Figure 21 — 19XL with Default Metric Settings**

**Figure 22 — Example of Attach to Network Device Screen**

**Figure 23 — Example of Holiday Period Screen**

**Figure 24 — Control Sequence**

**Figure 25 — Typical Wet-Bulb Type Vacuum Indicator**

**Figure 26 — 19XL Leak Test Procedures**

- Figure 27 — Typical Optional Pumpout System Piping Schematic with Storage Tank**
- Figure 28 — Typical Optional Pumpout System Piping Schematic without Storage Tank**
- Figure 29 — Dehydration Cold Trap**
- Figure 30 — Benshaw, Inc. Solid-State Starter Power Stack**
- Figure 31 — Ramp Up and Starting Torque Potentiometers**
- Figure 32 — Typical Potentiometer Adjustment**
- Figure 33 — Typical Cutler-Hammer® Solid-State Starter**
- Figure 34 — Correct Motor Rotation**
- Figure 35 — Refrigeration Log**
- Figure 36 — 19XL Pumpout Unit Wiring Schematic**
- Figure 37 — Optional Pumpout System**
- Figure 38 — Guide Vane Actuator Linkage**
- Figure 39 — 19XL Float Valve Designs**



**Figure 40 — Optional Pumpout System Controls**

**Figure 41 — PSIO Module Address Selector Switch Locations and LED Locations**

**Figure 42 — LID Module (Rear View) and LED Locations**

**Figure 43 — Processor (PSIO) Module**

**Figure 44 — Starter Management Module (SSM)**

**Figure 45 — Options Module**

**Figure 46 — Typical Benshaw, Inc. Solid-State Starter (Internal View)**

**Figure 47 — Resistance Check**

**Figure 48 — SCR and Power Poles**

**Figure 49 — Typical Cutler-Hammer® Solid-State Starter (Internal View)**

**Figure 50 — Cutler-Hammer Terminal Functions**

**Figure 51 — Solid-State Starter, General Operation Troubleshooting Guide (Typical)**

---

## Contents

---

**Figure 52 — Solid-State Starter, Starter Fault (Motor Will Not Start) Troubleshooting Guide (Typical)**

**Figure 53 — Compressor Fits and Clearances**

**Figure 54 — Compressor Fits and Clearances (Continued)**

**Figure 55 — Compressor Fits and Clearances (Continued)**

**Figure 56 — Electronic PIC Controls Wiring Schematic**

**Figure 57 — Machine Power Panel, Starter Assembly, and Motor Wiring Schematic**

**Figure 58 — Typical Wye-Delta Unit Mounted Starter Wiring Schematic**

## Introduction

Prior to initial start-up of the 19XL unit, those involved in the start-up, operation, and maintenance should be thoroughly familiar with these instructions and other necessary job data. This book is outlined so that you may become familiar with the control system before performing start-up procedures. Procedures in this manual are arranged in the sequence required for proper machine start-up and operation.



**WARNING**



**WARNING**

**This unit uses a microprocessor control system. Do not short or jumper between terminations on circuit boards or modules; control or board failure may result. Be aware of electrostatic discharge (static electricity) when handling or making contact with circuit boards or module connections. Always touch a chassis (grounded) part to dissipate body electrostatic charge before working inside control center.**

**Use extreme care when handling tools near boards and when connecting or disconnecting terminal plugs. Circuit boards can easily be damaged. Always hold boards by the edges and avoid touching components and connections.**

**This equipment uses, and can radiate, radio frequency energy. If not installed and used in accordance with the instruction manual, it may cause interference to radio communications. It has been tested and found to comply with the limits for a Class A computing device pursuant to Subpart J of Part 15 of FCC Rules, which are designed to provide reasonable protection against such interference when operated in a commercial environment. Operation of this equipment in a residential area is likely to cause interference, in which case the user, at his own expense, will be required to take whatever measures may be required to correct the interference.**

**Always store and transport replacement or defective boards in anti-static shipping bag.**



# Abbreviations and Explanations

Frequently used abbreviations in this manual include:

<b>CCN</b>	— Carrier Comfort Network	<b>LID</b>	— Local Interface Device
<b>CCW</b>	— Counterclockwise	<b>LCW</b>	— Leaving Chilled Water
<b>CW</b>	— Clockwise	<b>OLTA</b>	— Overload Trip Amps
<b>ECW</b>	— Entering Chilled Water	<b>PIC</b>	— Product Integrated Control
<b>ECDW</b>	— Entering Condenser Water	<b>PSIO</b>	— Processor Sensor Input/Output Module
<b>EMS</b>	— Energy Management System	<b>RLA</b>	— Rated Load Amps
<b>HGBP</b>	— Hot Gas Bypass	<b>SCR</b>	— Silicon Control Rectifier
<b>I/O</b>	— Input/Output	<b>SI</b>	— International System of Units
<b>LCD</b>	— Liquid Crystal Display	<b>SMM</b>	— Starter Management Module
<b>LCDW</b>	— Leaving Condenser Water	<b>TXV</b>	— Thermal Expansion Valve
<b>LED</b>	— Light-Emitting Diode		

The 19XL machines use HCFC-22 and HFC-134a refrigerant. When referencing refrigerant charges in this manual, the HCFC-22 charge will be listed first and the HFC-134a value will be shown next to it in [ ].

Words printed in all capital letters or in italics may be viewed on the LID.

The PSIO software version number of your 19XL unit will be located on the front cover.



# Machine Familiarization

([Figure 1](#), Figure 2A ([Front View](#)) ([Rear View](#)), and Figure 2B ([Front View](#)) ([Rear View](#)))

## Machine Information Plate

The information plate is located on the right side of the machine control center panel.

[Click here for Figure 1 — 19XL Identification](#)

## System Components

The components include the cooler and condenser heat exchangers in separate vessels, motor-compressor, lubrication package, control center, and motor starter. All connections from pressure vessels have external threads to enable each component to be pressure tested with a threaded pipe cap during factory assembly.

### Cooler

This vessel (also known as the evaporator) is located underneath the compressor. The cooler is maintained at lower temperature/pressure so that evaporating refrigerant can remove heat from water flowing through its internal tubes.

### Condenser

The condenser operates at a higher temperature/pressure than the cooler, and has water



flowing through its internal tubes in order to remove heat from the refrigerant.

## **Motor-Compressor**

This component maintains system temperature/pressure differences and moves the heat carrying refrigerant from the cooler to the condenser.

## **Control Center**

The control center is the user interface for controlling the machine. It regulates the machine's capacity as required to maintain proper leaving chilled water temperature. The control center:

- registers cooler, condenser, and lubricating system pressures
- shows machine operating condition and alarm shutdown conditions
- records the total machine operating hours
- sequences machine start, stop, and recycle under microprocessor control
- provides access to other CCN (Carrier Comfort Network) devices

## **Factory-Mounted Starter (Optional)**

The starter allows for the proper starting and disconnecting of the electrical energy for the compressor-motor, oil pump, oil heater, and control panels.

## **Storage Vessel (Optional)**

There are 2 sizes of storage vessels available. The vessels have double relief valves, a magnetically coupled dial-type refrigerant level gage, a one-inch FPT drain valve, and a 1/2-in. male flare vapor connection for the pumpout unit. A 30-in.-0-400 psi (-101- 0-2750 kPa) gage



also is supplied with each unit.

**Note:** If a storage vessel is not used at the jobsite, factory-installed isolation valves on the chiller may be used to isolate the machine charge in either the cooler or condenser. An optional pumpout compressor system is used to transfer refrigerant from vessel to vessel.

## Refrigeration Cycle

The compressor continuously draws refrigerant vapor from the cooler, at a rate set by the amount of guide vane opening. As the compressor suction reduces the pressure in the cooler, the remaining refrigerant boils at a fairly low temperature (typically 38 to 42 F [3 to 6 C]). The energy required for boiling is obtained from the water flowing through the cooler tubes. With heat energy removed, the water becomes cold enough for use in an air conditioning circuit or process liquid cooling.

After taking heat from the water, the refrigerant vapor is compressed. Compression adds still more heat energy and the refrigerant is quite warm (typically 98 to 102 F [37 to 40 C]) when it is discharged from the compressor into the condenser.

Relatively cool (typically 65 to 90 F [18 to 32 C]) water flowing into the condenser tubes removes heat from the refrigerant and the vapor condenses to liquid.

The liquid refrigerant passes through orifices into the FLASC (Flash Subcooler) chamber





(Figure 3). Since the FLASC chamber is at a lower pressure, part of the liquid refrigerant flashes to vapor, thereby cooling the remaining liquid. The FLASC vapor is recondensed on the tubes which are cooled by entering condenser water. The liquid drains into a float chamber between the FLASC chamber and cooler. Here a float valve forms a liquid seal to keep FLASC chamber vapor from entering the cooler. When liquid refrigerant passes through the valve, some of it flashes to vapor in the reduced pressure on the cooler side. In flashing, it removes heat from the remaining liquid. The refrigerant is now at a temperature and pressure at which the cycle began.

## Motor/Oil Refrigeration Cooling Cycle

The motor and the lubricating oil are cooled by liquid refrigerant taken from the bottom of the condenser vessel (Figure 3). Flow of refrigerant is maintained by the pressure differential that exists due to compressor operation. After the refrigerant flows past an isolation valve, an in-line filter, and a sight glass/moisture indicator, the flow is split between motor cooling and oil cooling systems.

Flow to the motor flows through an orifice and into the motor. There is also another orifice and a solenoid valve which will open if additional motor cooling is required. Once past the orifice, the refrigerant is directed over the motor by a spray nozzle. The refrigerant collects in the bottom of the motor casing and then is drained back into the cooler through the motor refrigerant drain line. A back pressure valve or an orifice in this line maintains a higher pressure



in the motor shell than in the cooler/oil sump. The motor is protected by a temperature sensor imbedded in the stator windings. Higher motor temperatures (above 125 F [51 C]) energize a solenoid to provide additional motor cooling. A further increase in temperature past the motor override set point will override the temperature capacity control to hold, and if the motor temperature rises 10° F (5.5° C) above this set point, will close the inlet guide vanes. If the temperature rises above the safety limit, the compressor will shut down.

Refrigerant that flows to the oil cooling system is regulated by a thermostatic expansion valve. There is always a minimum flow bypassing the TXV, which flows through an orifice. The TXV valve regulates flow into the oil/refrigerant plate and frame-type heat exchanger. The bulb for the expansion valve controls oil temperature to the bearings. The refrigerant leaving the heat exchanger then returns to the cooler.

[Click here for Figure 2A \(Front and Rear Views\) — Typical 19XL Components — Design I](#)

[Click here for Figure 2B \(Front and Rear Views\) — Typical 19XL Components — Design II](#)



[Click here for Figure 3 — Refrigerant Motor Cooling and Oil Cooling Cycles](#)

## Lubrication Cycle

### Summary

The oil pump, oil filter, and oil cooler make up a package located partially in the transmission casting of the compressor-motor assembly. The oil is pumped into a filter assembly to remove foreign particles, and is then forced into an oil cooler heat exchanger where the oil is cooled to proper operational temperatures. After the oil cooler, part of the flow is directed to the gears and the high speed shaft bearings; the remaining flow is directed to the motor shaft bearings. Oil drains into the transmission oil sump to complete the cycle ([Figure 4](#)).

### Details

Oil is charged into the lubrication system through a hand valve. Two sight glasses in the oil reservoir permit oil level observation. Normal oil level is between the middle of the upper sight glass and the top of the lower sight glass when the compressor is shut down. The oil level should be visible in at least one of the 2 sight glasses during operation. Oil sump temperature is displayed on the LID default screen. Oil sump temperature ranges during compressor operation between 100 to 120 F (37 to 49 C) [120 to 140 F (49 to 60 C)].



The oil pump suction is fed from the oil reservoir. An oil pressure relief valve maintains 18 to 25 psid (124 to 172 kPad) differential pressure in the system at the pump discharge. This differential pressure can be read directly from the Local Interface Device (LID) default screen. The oil pump discharges oil to the oil filter assembly. This filter is capable of being valved closed to permit removal of the filter without draining the entire oil system (see [Maintenance](#) sections for details). The oil is then piped to the oil cooler. This heat exchanger uses refrigerant from the condenser as the coolant. The refrigerant cools the oil to a temperature between 100 and 120 F (37 to 49 C).

As the oil leaves the oil cooler, it passes the oil pressure transducer and the thermal bulb for the refrigerant expansion valve on the oil cooler. The oil is then divided, with a portion flowing to the thrust bearing, forward pinion bearing, and gear spray. The balance then lubricates the motor shaft bearings and the rear pinion bearing. The oil temperature is measured as the oil leaves the thrust and forward journal bearings within the bearing housing. The oil then drains into the oil reservoir at the base of the compressor. The PIC (Product Integrated Control) measures the temperature of the oil in the sump and maintains the temperature during shutdown (see [Oil Sump Temperature Control](#) section). This temperature is read on the LID default screen.

During the machine start-up, the PIC will energize the oil pump and provide 15 seconds of prelubrication to the bearings after pressure is verified before starting the compressor. During shutdown, the oil pump will run for 60 seconds after the compressor shuts down for the purpose



of post-lubrication. The oil pump can also be energized for testing purposes in the Control Test.

Ramp loading can slow the rate of guide vane opening to minimize oil foaming at start-up. If the guide vanes open quickly, the sudden drop in suction pressure can cause any refrigerant in the oil to flash. The resulting oil foam cannot be pumped efficiently, therefore oil pressure falls off and lubrication is poor. If oil pressure falls below 15 psid (103 kPad) differential, the PIC will shut down the compressor.

[Click here for Figure 4 — Lubrication System](#)

## Oil Reclaim System

The oil reclaim system operates to return oil back to the oil reservoir by recovering it from 2 areas on the machine. The primary area of recovery is from the guide vane housing. Oil also is recovered, along with refrigerant, from the cooler.

Any refrigerant that enters the oil reservoir/transmission area is flashed into gas. The demister line at the top of the casing will vent this refrigerant into the suction of the compressor. Oil entrained in the refrigerant is eliminated by the demister filter.

**During Normal Machine Operation**, oil is entrained with the refrigerant. As the compressor pulls the refrigerant into the guide vane housing to be compressed, the oil will normally drop out at this point and fall to the bottom of the housing where it accumulates. Using



discharge gas pressure to power an eductor, the oil is vacuumed from the housing by the eductor and is discharged into the oil reservoir. Oil and refrigerant are also recovered from the top of the cooler refrigerant level and are discharged into the guide vane housing. The oil will drop to the bottom of the guide vane housing and be recovered by the eductor system.

**During Light Load Conditions**, the suction gas into the compressor does not have enough velocity to return oil, which is floating in the cooler back to the compressor. In addition, the eductor may not have enough power to pull the oil from the guide vane housing back into the oil reservoir due to extremely low pressure at the guide vanes. Two solenoids, located on the oil reclaim piping, are operated so that the eductor can pull oil and refrigerant directly from the cooler and discharge the mixture into the oil reservoir. The oil reclaim solenoids are operated by an auxiliary contact integral to the guide vane actuator. This switchover of the solenoids occurs when the guide vanes are opened beyond 30 degrees from the closed position.



## Starting Equipment

The 19XL requires a motor starter to operate the centrifugal hermetic compressor motor, the oil pump, and various auxiliary equipment. The starter serves as the main field wiring interface for the contractor.

Three types of starters are available from Carrier Corporation: solid-state, wye-delta, and across-the-line starters. See Carrier Specification Z-375 for specific starter requirements. All starters must meet these specifications in order to properly start and satisfy mechanical safety requirements. Starters may be supplied as separate, free-standing units, or may be mounted directly on the chiller (unit mounted) for low-voltage units only.

Inside the starter are 3 separate circuit breakers. Circuit breaker CB1 is the compressor motor circuit breaker. The disconnect switch on the starter front cover is connected to this breaker. Circuit breaker CB1 supplies power to the compressor motor.

**WARNING**



**WARNING**

**The main circuit breaker (CB1) on the front of the starter disconnects the main motor current only. Power is still energized for the other circuits. Two more circuit breakers inside the starter must be turned off to disconnect power to the oil pump, PIC controls, and oil heater.**



Circuit breaker CB2 supplies power to the control center, oil heater, and portions of the starter controls. Circuit breaker CB3 supplies power to oil pump. Both of these circuit breakers are wired in parallel with CB1 so that power is supplied to them if the CB1 disconnect is open.

All starters are shipped with a Carrier control module called the Starter Management Module (SMM). This module controls and monitors all aspects of the starter. See the [Controls](#) section for additional SMM information. All starter replacement parts are supplied by the starter manufacturer.

## Unit-Mounted Solid-State Starter (Optional)

The 19XL may be equipped with a solid-state, reduced-voltage starter ([Figure 5](#), [Figure 6](#), [Figure 7](#)). This starter provides on-off control of the compressor motor as its primary function. Using this type of starter reduces the peak starting torque, reduces the motor inrush current, and decreases mechanical shock. This is summed up by the phrase “soft starting.”

Two varieties of solid-state starters are available as a 19XL option (factory supplied and installed). When a unit-mounted, optional, solid-state starter is purchased with the 19XL, either a Benshaw, Inc. or Cutler-Hammer® solid-state starter will be shipped with the unit. See [Figure 5](#) and [Figure 6](#). The solid-state starter’s manufacturer name will be located inside the starter access door. See [Figure 7](#).

These starters operate by reducing the starting voltage. The starting torque of a motor at full voltage is typically 125% to 175% of the running torque. When the voltage and the current are





reduced at start-up, the starting torque is reduced as well. The object is to reduce the starting voltage to just the voltage necessary to develop the torque required to get the motor moving. The voltage and current are then ramped up in a desired period of time. The voltage is reduced through the use of silicon controlled rectifiers (SCR). Once full voltage is reached, a bypass contactor is energized to bypass the SCRs.

**WARNING**



**WARNING**

**When voltage is supplied to the solid-state circuitry, the heat sinks within the starter are at line voltage. Do not touch the heat sinks while voltage is present or serious injury will result.**

There are a number of LEDs (light-emitting diodes) that are useful in troubleshooting and starter checkout on Benshaw, Inc. solid-state starters. These are used to indicate:

- voltage to the SCRs
- SCR control voltage
- power indication
- proper phasing for rotation
- start circuit energized
- overtemperature
- ground fault



- current unbalance
- run state

These LEDs are further explained in the [Check Starter](#) and [Troubleshooting Guide](#) sections.

## **Unit-Mounted Wye-Delta Starter (Optional)**

The 19XL machine may be equipped with a wye-delta starter mounted on the unit. This starter is intended for use with low-voltage motors (under 600 v). It reduces the starting current inrush by connecting each phase of the motor windings into a wye configuration. This occurs during the starting period when the motor is accelerating up to speed. After a time delay, once the motor is up to speed, the starter automatically connects the phase windings into a delta configuration.

[Click here for Figure 5 — Cutler-Hammer® Solid-State Starter, Internal View](#)

[Click here for Figure 6 — Benshaw, Inc. Solid-State Starter, Internal View](#)

[Click here for Figure 7 — Typical Starter Front View \(Solid-State Starter Shown\)](#)



# Controls

## Definitions

### Analog Signal

*An analog signal* varies in proportion to the monitored source. It quantifies values between operating limits. (Example: A temperature sensor is an analog device because its resistance changes in proportion to the temperature, generating many values.)

### Digital Signal

*A digital (discrete) signal* is a 2-position representation of the value of a monitored source. (Example: A switch is a digital device because it only indicates whether a value is above or below a set point or boundary by generating an on/off, high/low, or open/closed signal.)

### Volatile Memory

*Volatile memory* is memory incapable of being sustained if power is lost and subsequently restored.

**CAUTION**



**CAUTION**

**The memory of the PSIO and LID modules are volatile. If the battery in a module is removed or damaged, all programming will be lost.**



## General

The 19XL hermetic centrifugal liquid chiller contains a microprocessor-based control center that monitors and controls all operations of the machine. The microprocessor control system matches the cooling capacity of the machine to the cooling load while providing state-of-the-art machine protection. The system controls cooling load within the set point plus the deadband by sensing the leaving chilled water or brine temperature, and regulating the inlet guide vane via a mechanically linked actuator motor. The guide vane is a variable flow prewhirl assembly that controls the refrigeration effect in the cooler by regulating the amount of refrigerant vapor flow into the compressor. An increase in guide vane opening increases capacity. A decrease in guide vane opening decreases capacity. Machine protection is provided by the processor which monitors the digital and analog inputs and executes capacity overrides or safety shutdowns, if required.

## PIC System Components

The Product Integrated Control (PIC) is the control system on the machine. See [Table 1](#). The PIC controls the operation of the machine by monitoring all operating conditions. The PIC can diagnose a problem and let the operator know what the problem is and what to check. It promptly positions the guide vanes to maintain leaving chilled water temperature. It can interface with auxiliary equipment such as pumps and cooling tower fans to turn them on only when required. It continually checks all safeties to prevent any unsafe operating condition. It



also regulates the oil heater while the compressor is off, and the hot gas bypass valve, if installed.

The PIC can be interfaced with the Carrier Comfort Network (CCN) if desired. It can communicate with other PIC-equipped chillers and other CCN devices.

The PIC consists of 3 modules housed inside the 3 major components. The component names and the control voltage contained in each component are listed below (also see [Table 1](#)):

- control center
  - all extra low-voltage wiring (24 v or less)
- power panel
  - 230 or 115 v control voltage (per job requirement)
  - up to 600 v for oil pump power
- starter cabinet
  - machine power wiring (per job requirement)

[Click here for Table 1 — Major PIC Components and Panel Locations](#)

## Processor Module (PSIO)

The PSIO is the brain of the PIC. This module contains all of the operating software needed



to control the machine. The 19XL uses 3 pressure transducers and 8 thermistors to sense pressures and temperatures. These are connected to the PSIO module. The PSIO also provides outputs to the: guide vane actuator; oil pump; oil heater; hot gas bypass (optional); motor cooling solenoid; and alarm contact. The PSIO communicates with the LID, the SMM, and the optional 8-input modules for user interface and starter management.

### **Starter Management Module (SMM)**

This module is located within the starter cabinet. This module initiates PSIO commands for starter functions such as start/stop of the compressor, start/stop of the condenser and chilled water pumps, start/stop of the tower fan, spare alarm contacts, and the shunt trip. The SMM monitors starter inputs such as flow switches, line voltage, remote start contact, spare safety, condenser high pressure, oil pump interlock, motor current signal, starter 1M and run contacts, and kW transducer input (optional). The SMM contains logic capable of safely shutting down the machine if communications with the PSIO are lost.

### **Local Interface Device (LID)**

The LID is mounted to the control center and allows the operator to interface with the PSIO or other CCN devices. It is the input center for all local machine set points, schedules, set-up functions, and options. The LID has a STOP button, an alarm light, 4 buttons for logic inputs, and a display. The function of the 4 buttons or “softkeys” are menu driven and are shown on the display directly above the key.



## **6-Pack Relay Board**

This device is a cluster of 6 pilot relays located in the control center. It is energized by the PSIO for the oil pump, oil heater, alarm, optional hot gas bypass relay, and motor cooling solenoid.

## **8-Input Modules**

One optional module is factory installed in the control center panel when ordered. There can be up to 2 of these modules per chiller with 8 spare inputs each. They are used whenever chilled water reset, demand reset, or reading a spare sensor is required. The sensors or 4 to 20 mA signals are field-installed.

The spare temperature sensors must have the same temperature/resistance curve as the other temperature sensors on this unit. These sensors are 5,000 ohm at 75 F (25 C).

## **Oil Heater Contactor (1C)**

This contactor is located in the power panel and operates the heater at either 115 or 230 v. It is controlled by the PIC to maintain oil temperature during machine shutdown.

## **Oil Pump Contactor (2C)**

This contactor is located in the power panel. It operates all 200 to 575-v oil pumps. The PIC energizes the contactor to turn on the oil pump as necessary.



## Hot Gas Bypass Contactor Relay (3C) (Optional)

This relay, located in the power panel, controls the opening of the hot gas bypass valve. The PIC energizes the relay during low load, high lift conditions.

## Control Transformers (T1-T4)

These transformers convert incoming control voltage to either 21 vac power for the PSIO module and options modules, or 24 vac power for 3 power panel contactor relays, 3 control solenoid valves, and the guide vane actuator. They are located in the power panel.

[Click here for Figure 8 — 19XL Controls and Sensor Locations](#)

[Click here for Figure 9 — Control Sensors \(Temperature\)](#)

[Click here for Figure 10 — Control Sensors \(Pressure Transducer, Typical\)](#)

[Click here for Figure 11 — Control Panel \(Front View\), with Options Module](#)





[Click here for Figure 12 — Power Panel with Options](#)

## Control and Oil Heater Voltage Selector (S1)

It is possible to use either 115 v or 230 v incoming control power in the power panel. The switch is set to the voltage used at the job site.

## LID Operation and Menus ( [Figure 13](#), [Figure 14](#), [Figure 15](#), [Figure 16](#), [Figure 17](#), [Figure 18](#), and [Figure 19](#) )

### General

- The LID display will automatically revert to the default screen after 15 minutes if no softkey activity takes place and if the machine is not in the Pumpdown mode ([Figure 13](#)).
- When not in the default screen, the upper right-hand corner of the LID always displays the name of the screen that you have entered ([Figure 14](#)).
- The LID may be configured in English or SI units, through the LID configuration screen.
- Local Operation — By pressing the LOCAL softkey, the PIC is now in the LOCAL operation mode and the control will accept modification to programming from the LID only. The PIC will use the Local Time Schedule to determine machine start and stop times.
- CCN Operation — By pressing the CCN softkey, the PIC is now in the CCN operation



mode, and the control will accept modifications from any CCN interface or module (with the proper authority), as well as the LID. The PIC will use the CCN time schedule to determine start and stop times.

## Alarms and Alerts

Alarm (\*) and alert (!) status are indicated on the Status tables. An alarm (\*) will shut down the compressor. An alert (!) notifies the operator that an unusual condition has occurred. The machine will continue to operate when an alert is shown.

[Click here for Figure 13 — LID Default Screen](#)

[Click here for Figure 14 — LID Service Screen](#)

Alarms are indicated when the control center alarm light (!) flashes. The primary alarm message is viewed on the default screen and an additional, secondary, message and troubleshooting information are sent to the Alarm History table.

When an alarm is detected, the LID default screen will freeze (stop updating) at the time of alarm. The freeze enables the operator to view the machine conditions at the time of alarm. The Status tables will show the updated information. Once all alarms have been cleared (by pressing the RESET softkey), the default LID screen will return to normal operation.



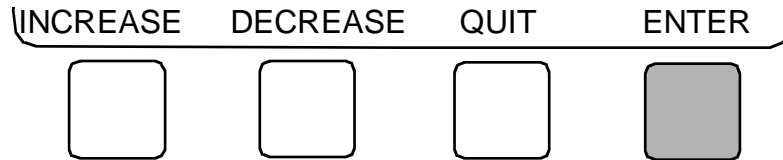
## Menu Structure

To perform any of the operations described below, the PIC must be powered up and have successfully completed its self test.

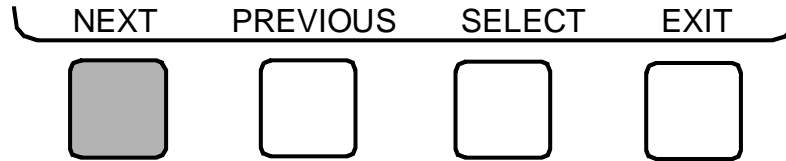
- Press QUIT to leave the selected decision or field without saving any changes.



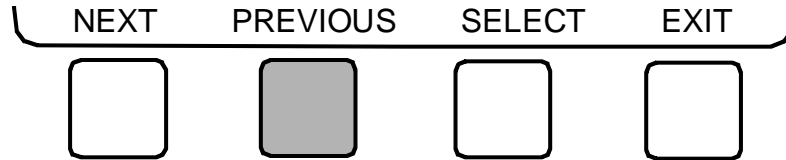
- Press ENTER to leave the selected decision or field and save changes.



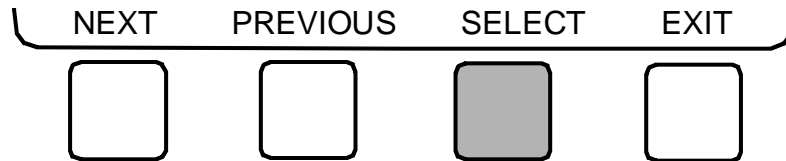
- Press NEXT to scroll the cursor bar down in order to highlight a point or to view more points below the current screen.



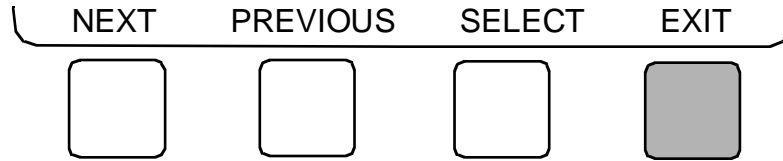
- Press PREVIOUS to scroll the cursor bar up in order to highlight a point or to view points above the current screen.



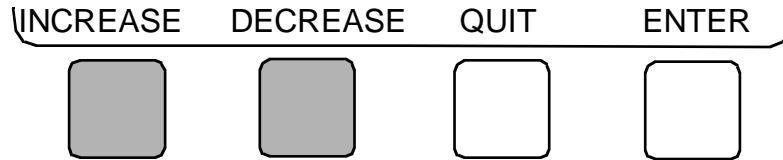
- Press SELECT to view the next screen level (highlighted with the cursor bar), or to override (if allowable) the highlighted point value.



- Press EXIT to return to the previous screen level.



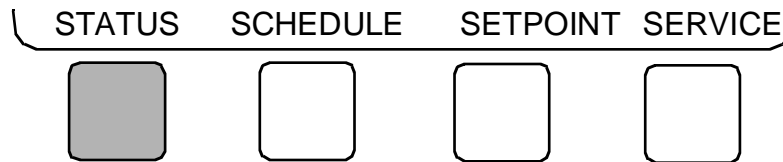
- Press INCREASE or DECREASE to change the highlighted point value.



## To View Point Status (Figure 15)

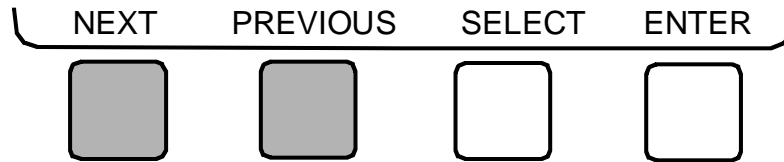
Point Status is the actual value of all of the temperatures, pressures, relays, and actuators sensed and controlled by the PIC.

1. On the Menu screen, press STATUS to view the list of Point Status tables.

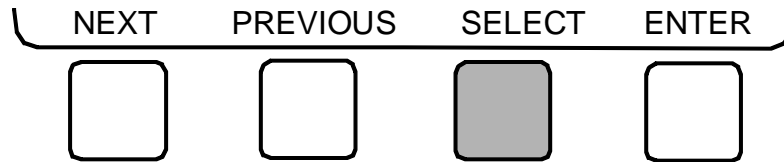


2. Press NEXT or PREVIOUS to highlight the desired status table. The list of tables is:

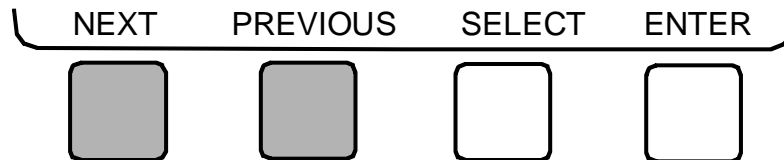
- Status01 — Status of control points and sensors
- Status02 — Status of relays and contacts
- Status03 — Status of both optional 8-input modules and sensors



3. Press SELECT to view the desired Point Status table desired.



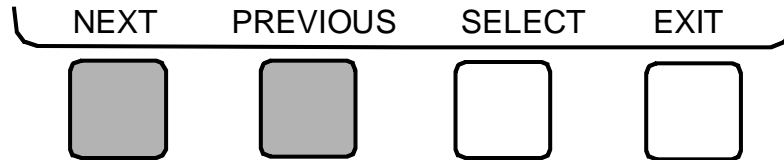
4. On the Point Status table press NEXT or PREVIOUS until desired point is displayed on the screen.



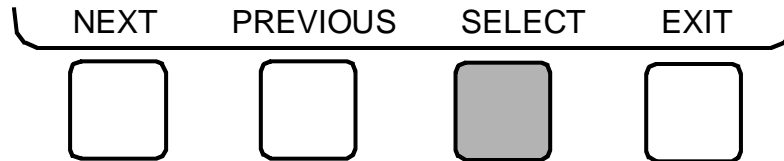
## Override Operations

### To Override a Value or Status

1. On the Point Status table press NEXT or PREVIOUS to highlight the desired point.



2. Press SELECT to select the highlighted point. Then:



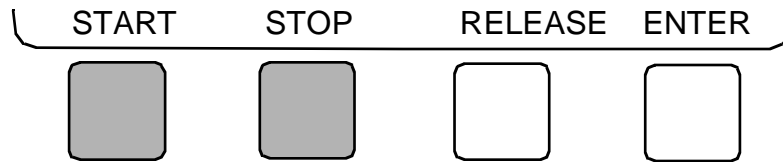
[Click here for Figure 15 — Example of Point Status Screen \(Status 01\)](#)

[Click here for Figure 16 — 19XL Menu Structure](#)

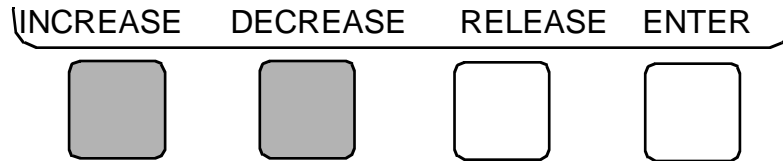


[Click here for Figure 17 — 19XL Service Menu Structure](#)

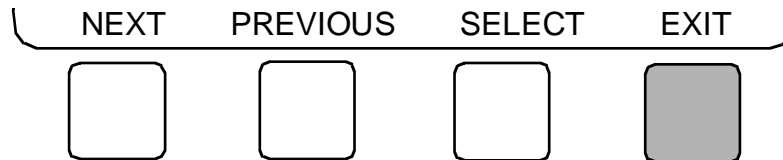
*For Discrete Points* — Press START or STOP to select the desired state.



*For Analog Points* — Press INCREASE or DECREASE to select the desired value.



3. Press ENTER to register new value.



**Note:** When overriding or changing metric values, it is necessary to hold the softkey down for a

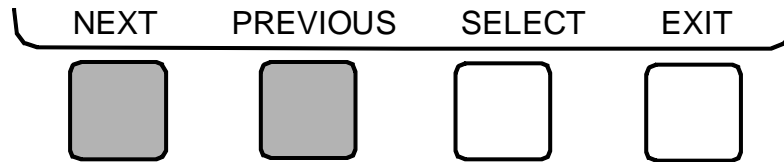




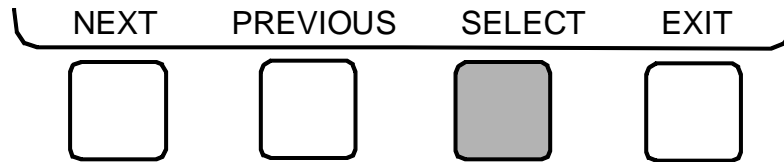
few seconds in order to see a value change, especially on kilopascal values.

## To Remove an Override

1. On the Point Status table press NEXT or PREVIOUS to highlight the desired point.



2. Press SELECT to access the highlighted point.



3. Press RELEASE to remove the override and return the point to the PIC's automatic control.



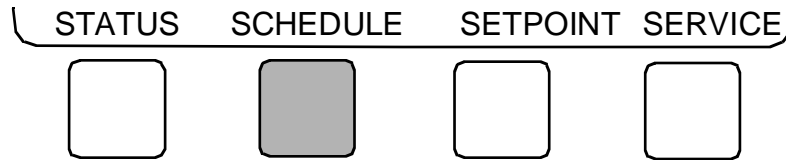
## Override Indication

An override value is indicated by "SUPVSR," "SERVC," or "BEST" flashing next to the point value on the Status table.



## Time Schedule Operation (Figure 18)

1. On the Menu screen, press SCHEDULE.



2. Press NEXT or PREVIOUS to highlight the desired schedule.

PSIO Software Version 08 and lower:

OCCPC01S — LOCAL Time Schedule

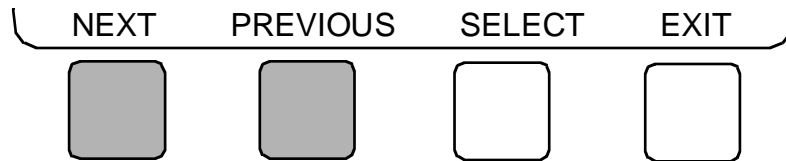
OCCPC02S — CCN Time Schedule

PSIO Software Version 09 and higher:

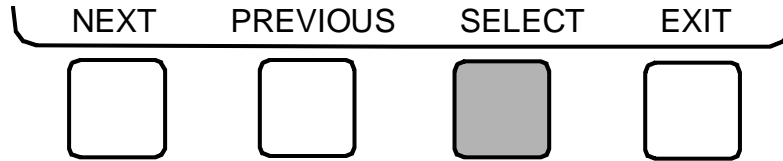
OCCPC01S — LOCAL Time Schedule

OCCPC02S — ICE BUILD Time Schedule

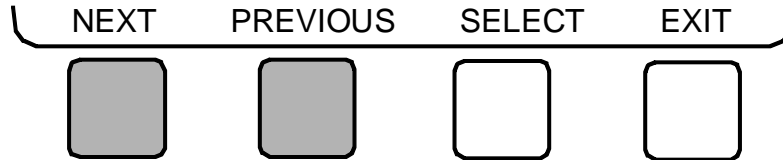
OCCPC03-99S — CCN Time Schedule (Actual number is defined in Config table.)



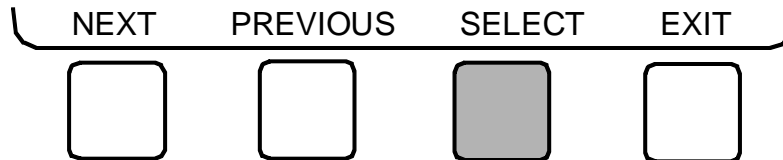
3. Press SELECT to access and view the time schedule.



4. Press NEXT or PREVIOUS to highlight the desired period or override that you wish to change.



5. Press SELECT to access the highlighted period or override.

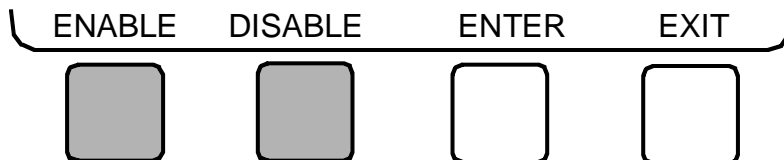


6.

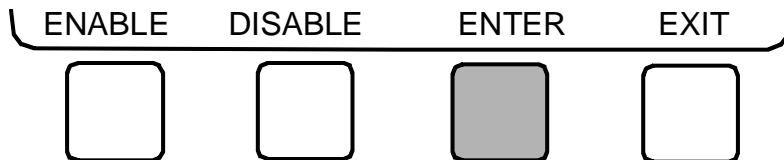
- a. Press INCREASE or DECREASE to change the time values. Override values are in one-hour increments, up to 4 hours.



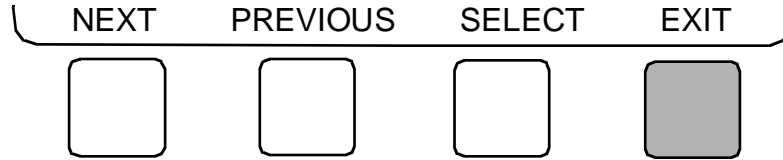
- b. Press ENABLE to select days in the day-of-week fields. Press DISABLE to eliminate days from the period.



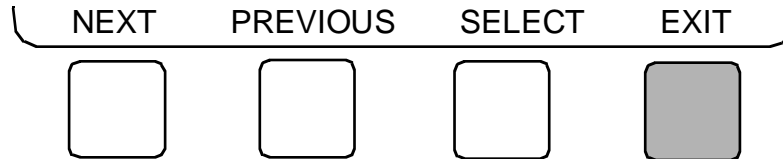
7. Press ENTER to register the values and to move horizontally (left to right) within a period.



8. Press EXIT to leave the period or override.



9. Either return to Step 4 to select another period or override, or press EXIT again to leave the current time schedule screen and save the changes.



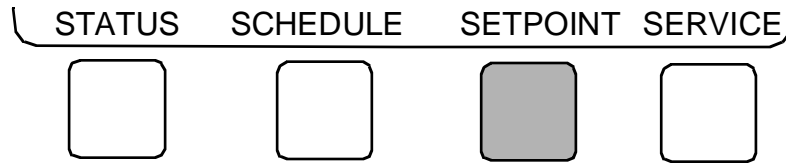
[Click here for Figure 18 — Example of Time Schedule Operation Screen](#)

10. Holiday Designation (HOLIDEF table) may be found in the [Service Operation](#) section. You must assign the month, day, and duration for the holiday. The Broadcast function in the Brodefns table also must be enabled for holiday periods to function.

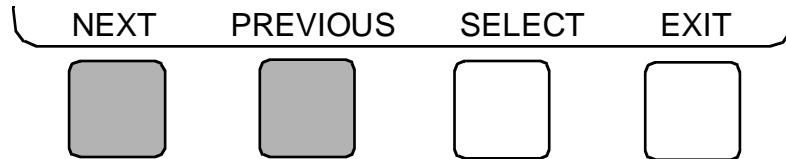


## To View and Change Set Points (Figure 19)

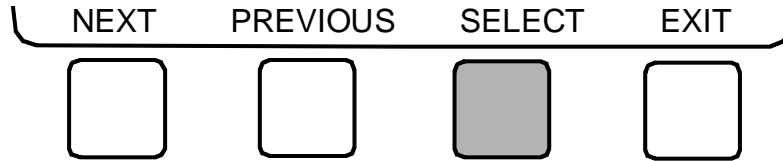
1. To view the Set Point table, at the Menu screen press SETPOINT.



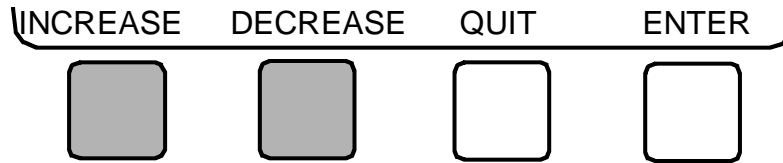
2. There are 4 set points on this screen: Base Demand Limit; LCW Set Point (leaving chilled water set point); ECW Set Point (entering chilled water set point); and ICE BUILD set point (PSIO Software Version 09 and higher only). Only one of the chilled water set points can be active at one time, and the type of set point is activated in the Service menu. ICE BUILD is also activated and configured in the Service menu.
3. Press NEXT or PREVIOUS to highlight the desired set point entry.



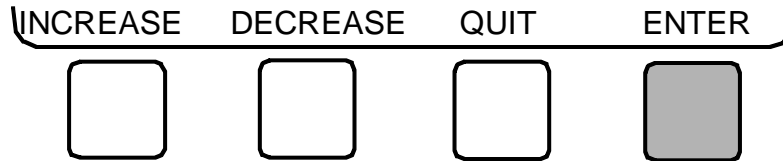
4. Press SELECT to modify the highlighted set point.



5. Press INCREASE or DECREASE to change the selected set point value.



6. Press ENTER to save the changes and return to the previous screen.



[Click here for Figure 19 — Example of Set Point Screen](#)



## Service Operation

To view the menu-driven programs available for Service Operation, see [Service Operation](#) section. For examples of LID display screens, see Table 2 (begins on this page).

### Table 2 — LID Screens

#### Note:

1. Only 12 lines of information appear on the LID screen at any given time. Press NEXT or PREVIOUS to highlight a point or to view points below or above the current screen.
2. The LID may be configured in English or SI units, as required, through the LID configuration screen.
3. Data appearing in the Reference Point Names column is used for CCN operations only.
4. All options associated with ICE BUILD, Lead/Lag, CCN Occupancy Configuration, and Soft Stopping are only available on PSIO Software Version 9 and higher.

#### Click on an example to view:

[Example 1 — Status01 Display Screen](#)

[Example 2 — Status02 Display Screen](#)

[Example 3 — Status03 Display Screen](#)

[Example 4 — Setpoint Display Screen](#)

[Example 5 — Configuration \(Config\) Display Screen](#)





## Table 2 — LID Screens (Continued)

**Click on an example to view:**

[Example 6 — Lead/Lag Configuration Display Screen](#)

[Example 7 — Service1 Display Screen](#)

[Example 8 — Service2 Display Screen](#)

[Example 9 — Service3 Display Screen](#)

[Example 10 — Maintenance \(Maint01\) Display Screen](#)

[Example 11 — Maintenance \(Maint02\) Display Screen](#)

[Example 12 — Maintenance \(Maint03\) Display Screen](#)

[Example 13 — Maintenance \(Maint04\) Display Screen](#)



## PIC System Functions

**Note:** Throughout this manual, words printed in capital letters and italics are values that may be viewed on the LID. See [Table 2](#) for examples of LID screens. Point names are listed in the Description column. An overview of LID operation and menus is given in [Figure 13](#), [Figure 14](#), [Figure 15](#), [Figure 16](#), [Figure 17](#), [Figure 18](#), and [Figure 19](#).

### Capacity Control

The PIC controls the machine capacity by modulating the inlet guide vanes in response to chilled water temperature changes away from the *CONTROL POINT*. The *CONTROL POINT* may be changed by a CCN network device, or is determined by the PIC adding any active chilled water reset to the chilled water *SET POINT*. The PIC uses the *PROPORTIONAL INC (Increase) BAND*, *PROPORTIONAL DEC (Decrease) BAND*, and the *PROPORTIONAL ECW (Entering Chilled Water) GAIN* to determine how fast or slow to respond. *CONTROL POINT* may be viewed/overridden on the Status table, Status01 selection.

### Entering Chilled Water Control

If this option is enabled, the PIC uses *ENTERING CHILLED WATER* temperature to modulate the vanes instead of *LEAVING CHILLED WATER* temperature. *ENTERING CHILLED WATER* control option may be viewed/modified on the Equipment Configuration table, Config table.



## Deadband

This is the tolerance on the chilled water/ brine temperature *CONTROL POINT*. If the water temperature goes outside of the *DEADBAND*, the PIC opens or closes the guide vanes in response until it is within tolerance. The PIC may be configured with a 0.5 to 2 F (0.3 to 1.1 C) deadband. *DEADBAND* may be viewed or modified on the Equipment Service1 table.

For example, a 1° F (0.6° C) deadband setting controls the water temperature within  $\pm 0.5^\circ$  F (0.3° C) of the control point. This may cause frequent guide vane movement if the chilled water load fluctuates frequently. A value of 1° F (0.6° C) is the default setting.

## Proportional Bands and Gain

Proportional band is the rate at which the guide vane position is corrected in proportion to how far the chilled water/brine temperature is from the control point. Proportional gain determines how quickly the guide vanes react to how quickly the temperature is moving from *CONTROL POINT*.

The proportional band can be viewed/modified on the LID. There are two response modes, one for temperature response above the control point, the other for response below the control point.

The first type is called *PROPORTIONAL INC BAND*, and it can slow or quicken vane response to chilled water/brine temperature above *DEADBAND*. It can be adjusted from a setting of 2 to 10; the default setting is 6.5. *PROPORTIONAL DEC BAND* can slow or quicken



vane response to chilled water temperature below deadband plus control point. It can be adjusted on the LID from a setting of 2 to 10, and the default setting is 6.0. Increasing either of these settings will cause the vanes to respond slower than a lower setting.

The *PROPORTIONAL ECW GAIN* can be adjusted at the LID display from a setting of 1.0 to 3.0, with a default setting of 2.0. Increase this setting to increase guide vane response to a change in entering chilled water temperature. The proportional bands and gain may be viewed/modified on the Equipment Service3 table.

## **Demand Limiting**

The PIC will respond to the *ACTIVE DEMAND LIMIT* set point by limiting the opening of the guide vanes. It will compare the set point to either *COMPRESSOR MOTOR LOAD* or *COMPRESSOR MOTOR CURRENT* (percentage), depending on how the control is configured for the *DEMAND LIMIT SOURCE* which is accessed on the SERVICE1 table. The default setting is current limiting.

## **Machine Timers**

The PIC maintains 2 runtime clocks, known as *COMPRESSOR ONTIME* and *SERVICE ONTIME*. *COMPRESSOR ONTIME* indicates the total lifetime compressor run hours. This timer can register up to 500,000 hours before the clock turns back to zero. The *SERVICE ONTIME* is a resettable timer that can be used to indicate the hours since the last service visit or any other reason. The time can be changed through the LID to whatever value is desired. This timer can



register up to 32,767 hours before it rolls over to zero.

The chiller also maintains a start-to-start timer and a stop-to-start timer. These timers limit how soon the machine can be started. See the [Start-Up/Shutdown/Recycle Sequence](#) section for operational information.

## Occupancy Schedule

This schedule determines when the chiller is either occupied or unoccupied.

Each schedule consists of from one to 8 occupied/unoccupied time periods, set by the operator. These time periods can be enabled to be in effect, or not in effect, on each day of the week and for holidays. The day begins with 0000 hours and ends with 2400 hours. The machine is in OCCUPIED mode unless an unoccupied time period is in effect.

The machine will shut down when the schedule goes to UNOCCUPIED. These schedules can be set up to follow the building schedule or to be 100% OCCUPIED if the operator wishes. The schedules also can be bypassed by forcing the Start/Stop command on the PIC Status screen to start. The schedules also can be overridden to keep the unit in an OCCUPIED mode for up to 4 hours, on a one-time basis.

**Figure 18** shows a schedule for a typical office building time schedule, with a 3-hour, off-peak cool down period from midnight to 3 a.m., following a weekend shutdown. Example: Holiday periods are unoccupied 24 hours per day. The building operates Monday through Friday, 7:00 a.m. to 6:00 p.m., with a Saturday schedule of 6:00 a.m. to 1:00 p.m., and includes the Monday



midnight to 3:00 a.m. weekend cool-down schedule.

**Note:** This schedule is for illustration only, and is not intended to be a recommended schedule for chiller operation.

### **PSIO Software Version 08 and Lower**

Whenever the chiller is in the LOCAL mode, the machine will start when the Occupancy Schedule 01 indicates OCCUPIED. When in the CCN mode, Occupancy Schedule 02 is used.

### **PSIO Software Version 09 and Higher**

The Local Time Schedule is still the Occupancy Schedule 01. The Ice Build Time Schedule is Schedule 02 and the CCN Default Time Schedule is Schedule 03. The CCN schedule number is defined on the Config table in the Equipment Configuration table. The schedule number can change to any value from 03 to 99. If this schedule number is changed on the Config table, the operator must use the Attach to Network Device table to upload the new number into the Schedule screen. See [Figure 17](#).



## Safety Controls

The PIC monitors all safety control inputs, and if required, shuts down the machine or limits the guide vanes to protect the machine from possible damage from any of the following conditions:

- high bearing temperature
- high motor winding temperature
- high discharge temperature
- low oil pressure
- low cooler refrigerant temperature/pressure
- condenser high pressure or low pressure
- inadequate water/brine cooler and condenser flow
- high, low, or loss of voltage
- excessive motor acceleration time
- excessive starter transition time
- lack of motor current signal
- excessive motor amps
- excessive compressor surge
- temperature and transducer faults

Starter faults or optional protective devices within the starter can shut down the machine.

These devices are dependent on what has been purchased as options.



**CAUTION**



**CAUTION**

**If compressor motor overload occurs, check the motor for grounded or open phases before attempting a restart.**

If the controller initiates a safety shutdown, it displays the fault on the LID display with a primary and a secondary message, and energizes an alarm relay in the starter and blinks the alarm light on the control center. The alarm is stored in memory and can be viewed in the PIC alarm table along with a message for troubleshooting.

To give a better warning as to the operating condition of the machine, the operator also can define alert limits on various monitored inputs. Safety contact and alert limits are defined in [Table 3](#). Alarm and alert messages are listed in the [Troubleshooting Guide](#) section.

[Click here for Table 3 — Protective Safety Limits and Control Settings  
\(and figure following table\)](#)





## Shunt Trip

The shunt trip function of the PIC is a safety trip. The shunt trip is wired from an output on the SMM to the motor circuit breaker. If the PIC tries to shut down the compressor through normal shutdown procedure but is unsuccessful for 30 seconds, the shunt trip output is energized and causes the circuit breaker to trip off. If ground fault protection has been applied to the starter, the ground fault trip will also energize the shunt trip to trip the circuit breaker.

## Default Screen Freeze

Whenever an alarm occurs, the LID default screen will freeze displaying the condition of the machine at the time of alarm. Knowledge of the operating state of the chiller at the time an alarm occurs is useful when troubleshooting. Current machine information can be viewed on the Status tables. Once all existing alarms are cleared (by pressing the RESET softkey), the default LID will return normal operation.

## Motor Cooling Control

Motor temperature is reduced by refrigerant entering the motor shell and evaporating. The refrigerant is regulated by the motor cooling relay. This relay will energize when the compressor is running and motor temperature is above 125 F (51.7 C). The relay will close when motor temperature is below 100 F (37.8 C). Note that there is always a minimum flow of refrigerant when the compressor is operating for motor cooling; the relay only controls additional refrigerant to the motor.



## Ramp Loading Control

The ramp loading control slows down the rate at which the compressor loads up. This control can prevent the compressor from loading up during the short period of time when the machine is started, and the chilled water loop has to be brought down to normal design conditions. This helps reduce electrical demand charges by slowly bringing the chilled water to control point. However, the total power draw during this period remains almost unchanged.

There are 2 methods of ramp loading with the PIC. Ramp loading can be based on chilled water temperature or on motor load.

1. Temperature ramp loading limits the rate at which either leaving chilled water or entering chilled water temperature decreases by an operator-configured rate. The lowest temperature ramp table will be used the first time the machine is started (at commissioning). The lowest temperature ramp rate will also be used if machine power has been off for 3 hours or more (even if the motor ramp load is selected).
2. Motor load ramp loading limits the rate at which the compressor motor current or compressor motor load increases by an operator-configured rate.

The *TEMP (Temperature) PULLDOWN*, *LOAD PULL DOWN*, and *SELECT RAMP TYPE* may be viewed/modified on the LID Equipment Configuration table, Config table (see [Table 2](#)). Motor load is the default type.



## Capacity Override (Table 4)

These can prevent some safety shutdowns caused by exceeding motor amperage limit, refrigerant low temperature safety limit, motor high temperature safety limit, and condenser high pressure limit. In all cases there are 2 stages of compressor vane control.

1. The vanes are held from opening further, and the status line on the LID indicates the reason for the override.
2. The vanes are closed until condition decreases below the first step set point, and then the vanes are released to normal capacity control.

Whenever the motor current demand limit set point is reached, it activates a capacity override, again with a 2-step process. Exceeding 110% of the rated load amps for more than 30 seconds will initiate a safety shutdown.

The compressor high lift (surge prevention) set point will cause a capacity override as well. When the surge prevention set point is reached, the controller normally will only hold the guide vanes from opening. If so equipped, the hot gas bypass valve will open instead of holding the vanes.

[Click here for Table 4 — Capacity Overrides](#)



## High Discharge Temperature Control

If the discharge temperature increases above 160 F (71.1 C) (PSIO Software Version 09 and higher) or 180 F (82 C) (PSIO Software Version 08 or lower), the guide vanes are proportionally opened to increase gas flow through the compressor. If the leaving chilled water temperature is then brought 5° F (2.8° C) below the control set point temperature, the controls will bring the machine into the recycle mode.

## Oil Sump Temperature Control

The oil sump temperature control is regulated by the PIC which uses the oil heater relay when the machine is shut down.

As part of the pre-start checks executed by the controls, oil sump temperature is compared against evaporator refrigerant temperature. If the difference between these 2 temperatures is 50 F (27.8 C) or less, the start-up will be delayed until the oil temperature is 50 F (27.8 C) or more. Once this temperature is confirmed, the start-up continues.

## PSIO Software Version 08 and Lower

The oil heater relay is energized whenever the chiller compressor is off, and the oil sump temperature is less than 140 F (60 C) or sump temperature is less than the cooler refrigerant temperature plus 60° F (33.3° C). The heater is then turned off when the oil sump temperature is: 1) more than 160 F (71.1 C); or 2) the sump temperature is more than 145 F (62.8 C) and more than the cooler refrigerant temperature plus 65° F (36.1° C). The heater is always off during start-up or when the compressor is running.



## PSIO Software Version 09 and Higher

The oil heater relay is energized whenever the chiller compressor is off and the oil sump temperature is less than 150 F (65.6 C) or the oil sump temperature is less than the cooler refrigerant temperature plus 70° F (39° C). The oil heater is turned off when the oil sump temperature is either 1) more than 160 F (71.1 C); or 2) the oil sump temperature is more than 155 F (68.3 C) and more than the cooler refrigerant temperature plus 75° F (41.6° C). The oil heater is always off during start-up or when the compressor is running.

When a power failure to the PSIO module has occurred for more than 3 hours (i.e., initial start-up), the oil sump is heated to 100° F (56° C) above the evaporator refrigerant temperature or 190 F (88 C), whichever is lower. Once this temperature is reached, the oil pump will be energized for 1 to 2 minutes or until the oil sump temperature cools to below 145 F (63 C). The normal heating algorithm is now followed once ramp loading has been completed.

After a 3-hour power failure, the oil temperature must rise to the higher oil temperature. The controls will delay the start of the compressor until this temperature is met.

### Oil Cooler

The oil must be cooled when the compressor is running. This is accomplished through a small, plate-type heat exchanger located behind the oil pump. The heat exchanger uses liquid condenser refrigerant as the cooling liquid. A refrigerant thermal expansion valve (TXV) regulates refrigerant flow to control oil temperature entering the bearings. There is always a flow



regulates refrigerant flow to control oil temperature entering the bearings. There is always a flow of refrigerant bypassing the thermal expansion valve (TXV). The bulb for the expansion valve is strapped to the oil supply line leaving the heat exchanger and the valve is set to maintain 110 F (43 C).

**Note:** The expansion valve is not adjustable. Oil sump temperature may be at a lower temperature.

## Remote Start/Stop Controls

A remote device, such as a time clock which uses a set of contacts, may be used to start and stop the machine. However, the device should not be programmed to start and stop the machine in excess of 2 or 3 times every 12 hours. If more than 8 starts in 12 hours occur, then an Excessive Starts alarm is displayed, preventing the machine from starting. The operator must reset the alarm at the LID in order to override the starts counter and start the machine. If Automatic Restart After a Power Failure is not activated when a power failure occurs, and the remote contact is closed, the machine will indicate an alarm because of the loss of voltage.

The contacts for Remote Start are wired into the starter at terminal strip TB5, terminals 8A and 8B. See the certified drawings for further details on contact ratings. The contacts must be dry (no power).

## Spare Safety Inputs

Normally closed (NC) digital inputs for additional field-supplied safeties may be wired to the



spare protective limits input channel in place of the factory-installed jumper. (Wire multiple inputs in series.) The opening of any contact will result in a safety shutdown and LID display. Refer to the certified drawings for safety contact ratings.

Analog temperature sensors may also be added to the options modules, if installed. These may be programmed to cause an alert on the CCN network, but will not shut the machine down.

### **Spare Alarm Contacts**

Two spare sets of alarm contacts are provided within the starter. The contact ratings are provided in the certified drawings. The contacts are located on terminal strip TB6, terminals 5A and 5B, and terminals 5C and 5D.

### **Condenser Pump Control**

The machine will monitor the *CONDENSER PRESSURE* and may turn on this pump if the pressure becomes too high whenever the compressor is shut down. *CONDENSER PRESSURE OVERRIDE* is used to determine this pressure point. This value is found on the Equipment Service1 LID table and has a default value ([Table 4](#)). If the *CONDENSER PRESSURE* is greater than or equal to the *CONDENSER PRESSURE OVERRIDE*, and the *ENTERING CONDENSER WATER TEMP (Temperature)* is less than 115 F (46 C), then the condenser pump will energize to try to decrease the pressure. The pump will turn off when the condenser pressure is less than the pressure override less 5 psi (34 kPa), or the *CONDENSER REFRIG (Refrigerant) TEMP* is within 3° F (2° C) of the *ENTERING CONDENSER WATER* temperature.



## Condenser Freeze Prevention

This control algorithm helps prevent condenser tube freeze-up by energizing the condenser pump relay. If the pump is controlled by the PIC, starting the pump will help prevent the water in the condenser from freezing. Condenser freeze prevention can occur whenever the machine is not running except when it is either actively in pumpdown or in Pumpdown Lockout with the freeze prevention disabled (refer to Control Test table, Pumpdown/Terminate Lockout tables).

When the CONDENSER REFRIG TEMP is less than or equal to the CONDENSER FREEZE POINT, or the ENTERING CONDENSER WATER temperature is less than or equal to the CONDENSER FREEZE POINT, then the CONDENSER WATER PUMP shall be energized until the CONDENSER REFRIG TEMP is greater than the CONDENSER FREEZE POINT plus 5° F (2.7° C). An alarm will be generated if the machine is in PUMPDOWN mode and the pump is energized. An alert will be generated if the machine is not in PUMPDOWN mode and the pump is energized. If in recycle shutdown, the mode shall transition to a non-recycle shutdown.

## Tower-Fan Relay

Low condenser water temperature can cause the chiller to shut down on low refrigerant temperature. The tower fan relay, located in the starter, is controlled by the PIC to energize and deenergize as the pressure differential between cooler and condenser vessels changes in order to prevent low condenser water temperature and to maximize machine efficiency. The tower-fan





relay can only accomplish this if the relay has been added to the cooling tower temperature controller. The *TOWER FAN RELAY* is turned on whenever the *CONDENSER WATER PUMP* is running, flow is verified, and the difference between cooler and condenser pressure is more than 45 psid (310 kPad) (30 psid [207 kPad] for HFC-134a) or entering condenser water temperature is greater than 85 F (29 C). The *TOWER FAN RELAY* is deenergized when the condenser pump is off, flow is lost, the evaporator refrigerant temperature is less than the override temperature, or the differential pressure is less than 40 psid (279 kPad) (28 psid [193 kPad] for HFC-134a) and entering condensing water is less than 80 F (27 C).

**IMPORTANT: A field-supplied water temperature control system for condenser water should be installed. The system should maintain the leaving condenser water temperature at a temperature that is 20° F (11° C) above the leaving chilled water temperature.**

**CAUTION**



**CAUTION**

**The tower-fan relay control is not a substitute for a condenser water temperature control. When used with a Water Temperature Control system, the tower fan relay control can be used to help prevent low condenser water temperatures.**



## **Auto. Restart After Power Failure**

This option may be enabled or disabled, and may be viewed/modified in the Config table of Equipment Configuration. If enabled, the chiller will start up automatically after a single cycle dropout, low, high, or loss of voltage has occurred, and the power is within  $\pm 10\%$  of normal. The 15- and 3-minute inhibit timers are ignored during this type of start-up.

When power is restored after the power failure, and if the compressor had been running, the oil pump will be energized for one minute prior to the evaporator pump energizing. Auto restart will then continue like a normal start-up.

If power to the PSIO module has been off for more than 3 hours, the PIC will raise the oil temperature  $100^{\circ}\text{F}$  ( $56^{\circ}\text{C}$ ) above the evaporator temperature. Refrigerant normally migrates into the oil when the oil heater is left off for extended periods of time. The PIC operates the oil pump for 1 to 2 minutes to ensure that the oil is free of excess refrigerant. Once this algorithm is completed, the RESTART of the chiller will continue.

## **Water/Brine Reset**

Three types of chilled water or brine reset are available and can be viewed or modified on the Equipment Configuration table Config selection.

The LID default screen status message indicates when the chilled water reset is active. The Control Point temperature on the Status01 table indicates the machine's current reset temperature.



To activate a reset type, input all configuration information for that reset type in the Config table. Then input the reset type number in the SELECT/ENABLE RESET TYPE input line.

1. Reset Type 1 (Requires optional 8-input module) — Automatic chilled water temperature reset based on a 4 to 20 mA input signal. This type permits up to  $\pm 30^{\circ}$  F ( $\pm 16^{\circ}$  C) of automatic reset to the chilled water or brine temperature set point, based on the input from a 4 to 20 mA signal. This signal is hardwired into the number one 8-input module.

If the 4-20 mA signal is externally powered from the 8-input module, the signal is wired to terminals J1-5(+) and J1- 6(-). If the signal is to be internally powered by the 8-input module (for example, when using variable resistance), the signal is wired to J1-7(+) and J1-6(-).

The PIC must now be configured on the Service2 table to ensure that the appropriate power source is identified.

2. Reset Type 2 (Requires optional 8-input module) — Automatic chilled water temperature reset based on a remote temperature sensor input. This type permits  $\pm 30^{\circ}$  F ( $\pm 16^{\circ}$  C) of automatic reset to the set point based on a temperature sensor wired to the number one 8-input module (see wiring diagrams or certified drawings).

The temperature sensor must be wired to terminal J1-19 and J1-20.

To configure Reset Type 2, enter the temperature of the remote sensor at the point where no temperature reset will occur. Next, enter the temperature at which the full amount of reset will occur. Then, enter the maximum amount of reset required to operate the machine.



Reset Type 2 can now be activated.

3. Reset Type 3 — Automatic chilled water temperature reset based on cooler temperature difference. This type of reset will add  $\pm 30^{\circ}$  F ( $\pm 16^{\circ}$  C) based on the temperature difference between entering and leaving chilled water temperature. This is the only type of reset available without the need of the number one 8-input module. No wiring is required for this type as it already uses the cooler water sensors.

To configure Reset Type 3, enter the chilled water temperature difference (the difference between entering and leaving chilled water) at which no temperature reset occurs. This chilled water temperature difference is usually the full design load temperature difference. The difference in chilled water temperature at which the full amount of reset will occur is now entered on the next input line. Next, the amount of reset is entered. Reset Type 3 can now be activated.



## **Demand Limit Control, Option — (Requires Optional 8-Input Module)**

The demand limit may be externally controlled with a 4 to 20 mA signal from an energy management system (EMS). The option is set up on the Config table. When enabled, the control is set for 100% demand with 4 mA and an operator configured minimum demand set point at 20 mA.

The Demand Reset input from an energy management system is hardwired into the number one, 8-input module. The signal may be internally powered by the module or externally powered. If the signal is externally powered, the signal is wired to terminals J1-1(+) and J1-2(-). If the signal is internally powered, the signal is wired to terminals J1-3(+) and J1-2(-). When enabled, the control is set for 100% demand with 4 mA and an operator configured minimum demand set point at 20 mA.

## **Surge Prevention Algorithm**

This is an operator configurable feature which can determine if lift conditions are too high for the compressor and then take corrective action. Lift is defined as the difference between the pressure at the impeller eye and the impeller discharge. The maximum lift that a particular impeller wheel can perform varies with the gas flow across the impeller, and the size of the wheel.

The algorithm first determines if corrective action is necessary. This is done by checking 2 sets of operator configured data points, which are the MINIMUM and the MAXIMUM Load



Points, (T1/P1;T2/P2). These points have default settings for each type of refrigerant, HCFC-22 or HFC-134a, as defined on the Service1 table, or on [Table 4](#). These settings and the algorithm function are graphically displayed in [Figure 20](#). The two sets of load points on this graph (default settings are shown) describe a line which the algorithm uses to determine the maximum lift of the compressor. Whenever the actual differential pressure between the cooler and condenser, and the temperature difference between the entering and leaving chilled water are above the line on the graph (as defined by the MINIMUM and MAXIMUM Load Points) the algorithm will go into a corrective action mode. If the actual values are below the line, the algorithm takes no action. Modification of the default set points of the MINIMUM and MAXIMUM load points is described in [Figure 21](#).

Corrective action can be taken by making one of 2 choices. If a hot gas bypass line is present, and the hot gas is configured on the Service1 table, then the hot gas bypass valve can be energized. If a hot gas bypass is not present, then the action taken is to hold the guide vanes. See [Table 4](#), Capacity Overrides. Both of these corrective actions will reduce the lift experienced by the compressor and help to prevent a surge condition. Surge is a condition when the lift becomes so high that the gas flow across the impeller reverses. This condition can eventually cause machine damage. The surge prevention algorithm is intended to notify the operator that machine operating conditions are marginal, and to take action to help prevent machine damage such as lowering entering condenser water temperature.



## Surge Protection

Surging of the compressor can be determined by the PIC through operator configured settings. Surge will cause amperage fluctuations of the compressor motor. The PIC monitors these amperage swings, and if the swing is greater than the configurable setting in one second, then one surge count has occurred. The SURGE DELTA PERCENT AMPS setting is displayed and configured on the Service1 screen. It has a default setting of 25% amps, SURGE PROTECTION COUNTS can be monitored on the Maint03 table.

A surge protection shutdown of the machine will occur whenever the surge protection counter reaches 12 counts within an operator specified time, known as the SURGE TIME PERIOD. The SURGE TIME PERIOD is displayed and configured on the Service1 screen. It has a default of 5 minutes.

[Click here for Figure 20 — 19XL Hot Gas Bypass/Surge Prevention](#)

[Click here for Figure 21 — 19XL with Default Metric Settings](#)



## Lead/Lag Control

**Note:** Lead/lag control is only available on machines with PSIO Software Version 09 or higher.

Lead/lag is a control system process that automatically starts and stops a lag or second chiller in a 2-chiller water system. Refer to [Figure 16](#) and [Figure 17](#) for menu, table, and screen selection information. On machines that have PSIO software with Lead/Lag capability, it is possible to utilize the PIC controls to perform the lead/lag function on 2 machines. A third machine can be added to the lead/lag system as a standby chiller to start up in case the lead or lag chiller in the system has shut down during an alarm condition and additional cooling is required.

**Note:** Lead/lag configuration is viewed and edited under Lead/Lag in the Equipment Configuration table (located in the Service menu). Lead/lag status during machine operation is viewed in the MAINT04 table in the Control Algorithm Status table. See [Table 2](#).

### Lead/Lag System Requirements:

- all machines must have PSIO software capable of performing the lead/lag function
- water pumps **MUST** be energized from the PIC controls
- water flows should be constant
- CCN Time Schedules for all machines must be identical





## Operation Features:

- 2 chiller lead/lag
- addition of a third chiller for backup
- manual rotation of lead chiller
- load balancing if configured
- staggered restart of the chillers after a power failure
- chillers may be piped in parallel or in series chilled water flow

## Common Point Sensor Installation

Lead/lag operation does not require a common chilled water point sensor. Common point sensors can be added to the 8-input option module, if desired. Refer to the certified drawings for termination of sensor leads.

**Note:** If the common point sensor option is chosen on a chilled water system, both machines should have their own 8-input option module and common point sensor installed. Each machine will use its own common point sensor for control, when that machine is designated as the lead chiller. The PIC cannot read the value of common point sensors installed on other machines in the chilled water system.

When installing chillers in series, a common point sensor should be used. If a common point sensor is not used, the leaving chilled water sensor of the upstream chiller must be moved into the leaving chilled water pipe of the downstream chiller.

If return chilled water control is required on chillers piped in series, the common point return



chilled water sensor should be installed. If this sensor is not installed, the return chilled water sensor of the downstream chiller must be relocated to the return chilled water pipe of the upstream machine.

To properly control the common supply point temperature sensor when chillers are piped in parallel, the water flow through the shutdown chillers must be isolated so that no water bypass around the operating chiller occurs. The common point sensor option must not be used if water bypass around the operating chiller is occurring.

## Machine Communication Wiring

Refer to the machine's Installation Instructions, [Carrier Comfort Network Interface](#) section for information on machine communication wiring.

## Lead/Lag Operation

The PIC control provides the ability to operate 2 chillers in the LEAD/LAG mode. It also provides the additional ability to start a designated standby chiller when either the lead or lag chiller is faulted and capacity requirements are not met. The lead/lag option operates in CCN mode only. If any other chiller configured for lead/lag is set to the LOCAL or OFF modes, it will be unavailable for lead/lag operation.

**Note:** Lead/lag configuration is viewed and edited in Lead/Lag, under the Equipment Configuration table of the Service menu. Lead/lag status during machine operation is viewed in the MAINT04 table in the Control Algorithm Status table.



## Lead/Lag Chiller Configuration and Operation

The configured lead chiller is identified when the LEAD/LAG SELECT value for that chiller is configured to the value of "1." The configured lag chiller is identified when the LEAD/LAG SELECT for that chiller is configured to the value of "2." The standby chiller is configured to a value of "3." A value of "0" disables the lead/lag in that chiller.

To configure the LAG ADDRESS value on the LEAD/LAG Configuration table, always use the address of the other chiller on the system for this value. Using this address will make it easier to rotate the lead and lag machines.

If the address assignments placed into the LAG ADDRESS and STANDBY ADDRESS values conflict, the lead/lag will be disabled and an alert (!) message will occur. For example, if the LAG ADDRESS matches the lead machine's address, the lead/lag will be disabled and an alert (!) message will occur. The lead/lag maintenance screen (MAINT04) will display the message 'INVALID CONFIG' in the LEAD/LAG CONFIGURATION and CURRENT MODE fields.

The lead chiller responds to normal start/stop controls such as occupancy schedule, forced start/stop, and remote start contact inputs. After completing start up and ramp loading, the PIC evaluates the need for additional capacity. If additional capacity is needed, the PIC initiates the start up of the chiller configured at the LAG ADDRESS. If the lag chiller is faulted (in alarm) or is in the OFF or LOCAL modes, then the chiller at the STANDBY ADDRESS (if configured) is



requested to start. After the second chiller is started and is running, the lead chiller shall monitor conditions and evaluate whether the capacity has reduced enough for the lead chiller to sustain the system alone. If the capacity is reduced enough for the lead chiller to sustain the CONTROL POINT temperatures alone, then the operating lag chiller is stopped.

If the lead chiller is stopped in CCN mode for any reason other than an alarm (\*) condition, then the lag and standby chillers are stopped. If the configured lead chiller stops for an alarm condition, then the configured lag chiller takes the lead chiller's place as the lead chiller and the standby chiller serves as the lag chiller.

If the configured lead chiller does not complete the start-up before the PRESTART FAULT TIMER (user configured value) elapses, then the lag chiller shall be started and the lead chiller will shut down. The lead chiller then monitors the start request from the acting lead chiller to start. The PRESTART FAULT TIMER is initiated at the time of a start request. The PRESTART FAULT TIMER's function is to provide a timeout in the event that there is a prestart alert condition preventing the machine from starting in a timely manner. The timer is configured under Lead/Lag, found in the Equipment Configuration table of the Service menu.

If the lag chiller does not achieve start-up before the PRESTART FAULT TIMER elapses, then the lag chiller shall be stopped and the standby chiller will be requested to start, if configured and ready.



## Standby Chiller Configuration and Operation

The configured standby chiller is identified as such by having the LEAD/LAG SELECT configured to the value of “3.” The standby chiller can only operate as a replacement for the lag chiller if one of the other two chillers is in an alarm (\*) condition (as shown on the LID panel). If both lead and lag chillers are in an alarm (\*) condition, the standby chiller shall default to operate in CCN mode based on its configured Occupancy Schedule and remote contacts input.

### Lag Chiller Start-Up Requirements

Before the lag chiller can be started, the following conditions must be met:

1. Lead chiller ramp loading must be complete.
2. Lead chiller CHILLED WATER temperature must be greater than the CONTROL POINT plus 1/2 the WATER/BRINE DEADBAND.

**Note:** The chilled water temperature sensor may be the leaving chilled water sensor, the return water sensor, the common supply water sensor, or the common return water sensor, depending on which options are configured and enabled.

3. Lead chiller ACTIVE DEMAND LIMIT value must be greater than 95% of full load amps.
4. Lead chiller temperature pulldown rate of the CHILLED WATER temperature is less than 0.5° F (0.27° C) per minute.
5. The lag chiller status indicates it is in CCN mode and is not faulted. If the current lag chiller is in an alarm condition, then the standby chiller becomes the active lag chiller, if it is configured and available.



6. The configured LAG START TIMER entry has elapsed. The LAG START TIMER shall be started when the lead chiller ramp loading is completed. The LAG START TIMER entry is accessed by selecting Lead/Lag from the Equipment Configuration table of the Service menu.

When all of the above requirements have been met, the lag chiller is forced to a START mode. The PIC control then monitors the lag chiller for a successful start. If the lag chiller fails to start, the standby chiller, if configured, is started.

### **Lag Chiller Shutdown Requirements**

The following conditions must be met in order for the lag chiller to be stopped.

1. Lead chiller COMPRESSOR MOTOR LOAD value is less than the lead chiller percent capacity plus 15%.

**Note:** Lead chiller percent capacity =  $100 - \text{LAG PERCENT CAPACITY}$

The LAG PERCENT CAPACITY value is configured on the Lead/Lag Configuration screen.

2. The lead chiller chilled water temperature is less than the CONTROL POINT plus 1/2 of the WATER/BRINE DEADBAND.
3. The configured LAG STOP TIMER entry has elapsed. The LAG STOP TIMER is started when the CHILLED WATER TEMPERATURE is less than the CHILLED WATER CONTROL POINT plus 1/2 of the WATER/BRINE DEADBAND and the lead chiller



COMPRESSOR MOTOR LOAD is less than the lead chiller percent capacity plus 15%. The timer is ignored if the chilled water temperature reaches 3° F (1.67° C) below the CONTROL POINT and the lead chiller COMPRESSOR MOTOR LOAD value is less than the lead chiller percent capacity plus 15%.

## **Faulted Chiller Operation**

If the lead chiller shuts down on an alarm (\*) condition, it stops communication to the lag and standby chillers. After 30 seconds, the lag chiller will now become the acting lead chiller and will start and stop the standby chiller, if necessary.

If the lag chiller faults when the lead chiller is also faulted, the standby chiller reverts to a stand-alone CCN mode of operation.

If the lead chiller is in an alarm (\*) condition (as shown on the LID panel), the RESET softkey is pressed to clear the alarm, and the chiller is placed in the CCN mode, the lead chiller will now communicate and monitor the RUN STATUS of the lag and standby chillers. If both the lag and standby chillers are running, the lead chiller will not attempt to start and will not assume the role of lead chiller until either the lag or standby chiller shuts down. If only one chiller is running, the lead chiller will wait for a start request from the operating chiller. When the configured lead chiller starts, it assumes its role as lead chiller.



## Load Balancing

When the LOAD BALANCE OPTION is enabled, the lead chiller will set the ACTIVE DEMAND LIMIT in the lag chiller to the lead chiller's COMPRESSOR MOTOR LOAD value. This value has limits of 40% to 100%. When setting the lag chiller ACTIVE DEMAND LIMIT, the CONTROL POINT shall be modified to a value of 3° F (1.67° C) less than the lead chiller's CONTROL POINT value. If the LOAD BALANCE OPTION is disabled, the ACTIVE DEMAND LIMIT and the CONTROL POINT are forced to the same value as the lead chiller.

## Auto. Restart After Power Failure

When an autorestart condition occurs, each chiller may have a delay added to the start-up sequence, depending on its lead/lag configuration. The lead chiller does not have a delay. The lag chiller has a 45 second delay. The standby chiller has a 90 second delay. The delay time is added after the chiller water flow verification. The PIC controls ensure that the guide vanes are closed. After the guide vane position is confirmed, the delay for lag and standby chiller occurs prior to energizing the oil pump. The normal start-up sequence then continues. The auto. restart delay sequence occurs whether the chiller is in CCN or LOCAL mode and is intended to stagger the compressor motors from being energized simultaneously. This will help reduce the inrush demands on the building power system.





## Ice Build Control

**IMPORTANT: The Ice Build control option is only available on machines with PSIO Software Version 09 and higher.**

Ice build control automatically sets the chilled WATER/ BRINE CONTROL POINT of the machine to a temperature where an ice building operation for thermal storage can be accomplished.

**Note:** For ice build control to properly operate, the PIC controls must be placed in CCN mode.

See [Figure 16](#) and [Figure 17](#).

The PIC can be configured for ice build operation. Configuration of ice build control is accomplished through entries in the Config table, Ice Build Setpoint table, and the Ice Build Time Schedule table. [Figure 16](#) and [Figure 17](#) show how to access each entry.

The Ice Build Time Schedule defines the period during which ice build is active if the ice build option is ENABLED. If the Ice Build Time Schedule overlaps other schedules defining time, then the Ice Build Time Schedule shall take priority. During the ice build period, the WATER/BRINE CONTROL POINT is set to the ICE BUILD SETPOINT for temperature control. The ICE BUILD RECYCLE OPTION and ICE BUILD TERMINATION entries from a screen in the Config (configuration) table provide options for machine recycle and termination of ice build cycle, respectively. Termination of ice build can result from the ENTERING CHILLED WATER/BRINE



temperature being less than the ICE BUILD SETPOINT, opening of the REMOTE CONTACT inputs from an ice level indicator, or reaching the end of the Ice Build Time Schedule.

## Ice Build Initiation

The Ice Build Time Schedule provides the means for activating ice build. The ice build time table is named OCCPC02S.

If the Ice Build Time Schedule is OCCUPIED and the ICE BUILD OPTION is ENABLED, then ice build is active and the following events automatically take place (unless overridden by a higher authority CCN device):

1. Force CHILLER START/STOP to START.
2. Force WATER/BRINE CONTROL POINT to the ICE BUILD SETPOINT.
3. Remove any force (Auto) on the ACTIVE DEMAND LIMIT.

**Note:** Items 1-3 (shown above) shall not occur if the chiller is configured and operating as a lag or standby chiller for lead/lag and is actively controlled by a lead chiller. The lead chiller communicates the ICE BUILD SETPOINT, desired CHILLER START/STOP state, and ACTIVE DEMAND LIMIT to the lag or standby chiller as required for ice build, if configured to do so.



## Start-Up/Recycle Operation

If the machine is not running when ice build activates, then the PIC checks the following parameters, based on the ICE BUILD TERMINATION value, to avoid starting the compressor unnecessarily:

- if ICE BUILD TERMINATION is set to the TEMPERATURE ONLY OPTION and the ENTERING CHILLED WATER temperature is less than or equal to the ICE BUILD SETPOINT;
- if ICE BUILD TERMINATION is set to the CONTACTS ONLY OPTION and the remote contacts are open;
- if the ICE BUILD TERMINATION is set to the BOTH (temperature and contacts) option and ENTERING CHILLED WATER temperature is less than or equal to the ICE BUILD SETPOINT and remote contacts are open.

The ICE BUILD RECYCLE OPTION determines whether or not the PIC will go into a RECYCLE mode. If the ICE BUILD RECYCLE OPTION is set to DSABLE (disable) when the ice build terminates, the PIC will revert back to normal temperature control duty. If the ICE BUILD RECYCLE OPTION is set to ENABLE, when ice build terminates, the PIC will go into an ICE BUILD RECYCLE mode and the chilled water pump relay will remain energized to keep the chilled water flowing. If the entering CHILLED WATER/BRINE TEMPERATURE increases above the ICE BUILD SETPOINT plus the RECYCLE DELTA T value, the compressor will restart and control the CHILLED WATER/ BRINE TEMPERATURE to the ICE BUILD SETPOINT.



## Temperature Control During Ice Build

During ice build, the capacity control algorithm uses the WATER/BRINE CONTROL POINT minus 5 F (2.7 C) to control the LEAVING CHILLED WATER temperature. The ECW OPTION and any temperature reset option are ignored during ice build. The 20 mA DEMAND LIMIT OPTION is also ignored during ice build.

## Termination Of Ice Build

Ice build termination occurs under the following conditions:

1. Ice Build Time Schedule — When the Ice Build Time Schedule transitions to UNOCCUPIED, ice build operation shall terminate.
2. ECW TEMPERATURE —Termination of compressor operation, based on temperature, shall occur if the ICE BUILD TERMINATION is set to the ICE BUILD TERMINATION TEMP option and the ENTERING CHILLED WATER temperature is less than the ICE BUILD SETPOINT. If the ICE BUILD RECYCLE OPTION is set to ENABLE, a recycle shutdown occurs and recycle start-up shall be based on LEAVING CHILLED WATER temperature being greater than the WATER/BRINE CONTROL POINT plus RECYCLE DELTA T.
3. Remote Contacts/Ice Level Input —Termination of compressor operation occurs when ICE BUILD TERMINATION is set to CONTACTS ONLY OPTION and the remote contacts are open. In this case, the contacts are provided for ice level termination control. The remote contacts can still be opened and closed to start and stop the chiller when the Ice Build Time



Schedule is UNOCCUPIED. The contacts are used to stop the ICE BUILD mode when the Ice Build Time Schedule is OCCUPIED.

4. ECW TEMPERATURE and Remote Contacts — Termination of compressor operation shall occur when ICE BUILD TERMINATION is set to BOTH (temperature and contacts) option and the previously described conditions for ECW TEMPERATURE and remote contacts have occurred.

**Note:** Overriding the CHILLER START/STOP, WATER/ BRINE CONTROL POINT, and ACTIVE DEMAND LIMIT variables by CCN devices (with a priority less than 4) during the ice build period is not possible. However, overriding can be accomplished with CCN during two chiller lead/ lag.

## **Return to Non-Ice Build Operations**

Upon termination of ice build, the machine shall return to normal temperature control and start/stop schedule operation. If the CHILLER START/ STOP or WATER/BRINE CONTROL POINT has been forced (with a priority less than 4), prior to entering ice build operation, then chiller START/STOP and WATER/BRINE CONTROL POINT forces will be removed.



## Attach to Network Device Control

On the Service menu, one of the selections is ATTACH TO NETWORK DEVICE. This table serves the following purposes:

- to upload new parameters when switching the controller to HFC-134a refrigerant.
- to upload the Occupancy Schedule Number (if changed) for OCCPC03S, as defined in the Service01 table
- to attach the LID to any CCN device, if the machine has been connected to a CCN Network. This may include other PIC controlled chillers.
- to change to a new PSIO or LID module or upgrade software.

Figure 22 illustrates the ATTACH TO NETWORK DEVICE table. The Local description is always the PSIO module address of the machine the LID is mounted on. Whenever the controller identification of the PSIO is changed, this change is reflected on the bus and address for the LOCAL DEVICE of the ATTACH TO DEVICE screen automatically. See Figure 17.

Whenever the ATTACH TO NETWORK DEVICE table is entered, the LID erases information on the module to which it was attached in order to make room for another device. Therefore, it is then required to attach to a CCN module when this screen is entered, even if the LID is attached back to the original module. When the ATTACH softkey is pressed, the message “UPLOADING TABLES, PLEASE WAIT” flashes. The LID will then upload the highlighted device or module. If the module address cannot be found, the message “COMMUNICATION FAILURE” will appear. The LID will then revert back to the ATTACH TO DEVICE screen. The upload process time for



various CCN modules is different for each module. In general, the uploading process will take 3 to 5 minutes.

## **Changing Refrigerant Types**

To select refrigerant type, go to the Control Test table. Whenever the refrigerant type is changed, the ATTACH TO NETWORK DEVICE table must be used. After changing the refrigerant type in the Control Test table, move to the ATTACH TO NETWORK DEVICE table. Make sure the highlight bar is located on the LOCAL selection. Press the ATTACH softkey. The information in the PSIO module will now be uploaded. The default screen will appear. The new refrigerant type change for the controller is complete.

## **Attaching to Other CCN Modules**

If the machine PSIO has been connected to a CCN Network or other PIC controlled chillers through CCN wiring, the LID can be used to view or change parameters on the other controllers. Other PIC machines can be viewed and set points changed (if the other unit is in CCN control), if desired from this particular LID module.

To view the other devices, move to the ATTACH TO NETWORK DEVICE table. Move the highlight bar to any device number. Press SELECT softkey to change the bus number and address of the module to be viewed. Press EXIT softkey to move back to the ATTACH TO NETWORK DEVICE table. If the module number is not valid, the “COMMUNICATION FAILURE” message will show and a new address number should be entered or the wiring



checked. If the model is communicating properly, the “UPLOAD IN PROGRESS” message will flash and the new module can now be viewed.

Whenever there is a question regarding which module on the LID is currently being shown, check the device name descriptor on the upper left hand corner of the LID screen. See [Figure 22](#).

When the CCN device has been viewed, the ATTACH TO NETWORK DEVICE table should now be used to attach to the PIC that is on the machine. Move to the ATTACH TO NETWORK DEVICE table and press the ATTACH softkey to upload the LOCAL device. The PSIO for the 19XL will now be uploaded.

**Note:** The LID will not automatically re-attach to the PSIO module on the machine. Press the ATTACH softkey to attach to LOCAL DEVICE and view the machine PSIO.

[Click here for Figure 22 — Example of Attach to Network Device Screen](#)





## Service Operation

An overview of the menu-driven programs available for Service Operation is shown in [Figure 17](#).

### To Log On

1. On the Menu screen, press SERVICE. The keys now correspond to the numerals 1, 2, 3, 4.
2. Press the four digits of your password, one at a time. An asterisk (\*) appears as you enter each digit.

ENTER A 4 DIGIT PASSWORD:\*

1	2	3	4
<input type="text"/>	<input type="text"/>	<input type="text"/>	<input type="text"/>

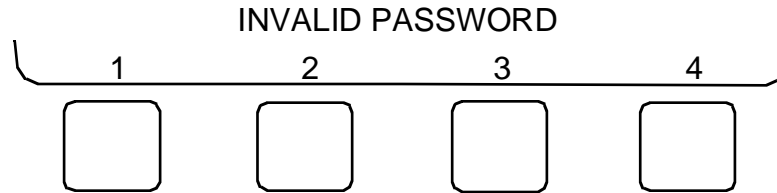
The menu bar (Next-Previous-Select-Exit) is displayed to indicate that you have successfully logged on.

NEXT	PREVIOUS	SELECT	EXIT
<input type="text"/>	<input type="text"/>	<input type="text"/>	<input type="text"/>

If the password is entered incorrectly, an error message is displayed. If this occurs, return to



Step 1 and try logging on again.



**Note:** The initial factory set password is 1-1-1-1.

## To Log Off

Access the Log Out of Device table of the Service menu in order to password-protect the Service menu. The LID will automatically sign off and password-protect itself if a key is not pressed for 15 minutes. The LID default screen is then displayed.

## Holiday Scheduling (Figure 23)

The time schedules may be configured for special operation during a holiday period. When modifying a time period, the “H” at the end of the days of the week field signifies that the period is applicable to a holiday. (See Figure 18.)

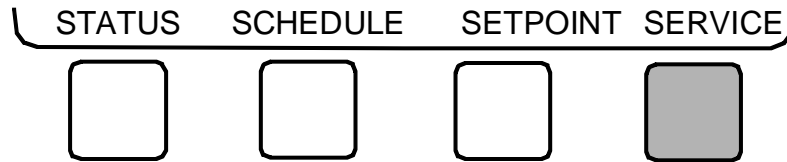
The Broadcast function must be activated for the holidays configured in the Holidef tables to work properly. Access the Brodefs table in the Equipment Configuration table and answer “Yes” to the activated function. However, when the machine is connected to a CCN Network, only one machine or CCN device can be configured to be the broadcast device. The controller



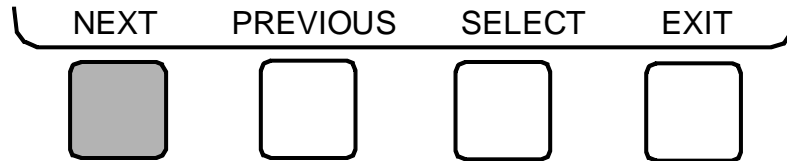
that is configured to be the broadcaster is the device responsible for transmitting holiday, time, and daylight-savings dates throughout the network.

To view or change the holiday periods for up to 18 different holidays, perform the following operation:

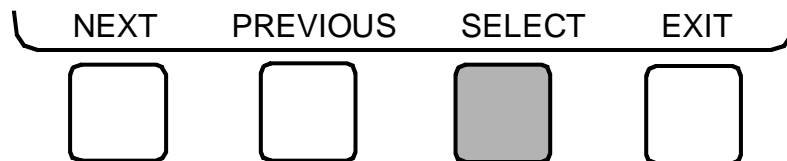
1. At the Menu screen, press SERVICE to access the Service menu.



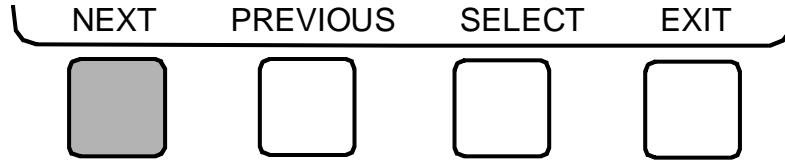
2. If not logged on, follow the instructions for To Log On or To Log Off. Once logged on, press NEXT until Equipment Configuration is highlighted.



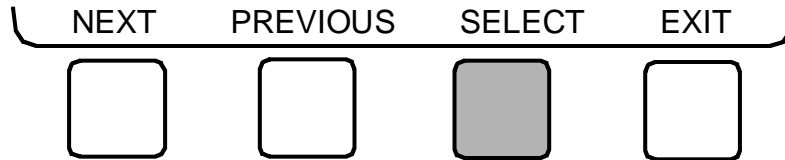
3. Once Equipment Configuration is highlighted, press SELECT to access.



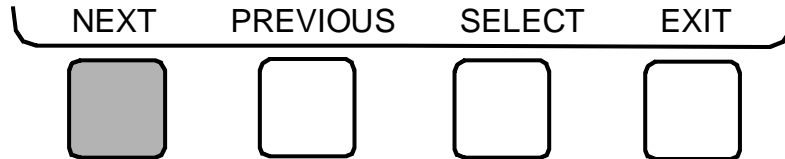
4. Press NEXT until Holiddef is highlighted. This is the Holiday Definition table.



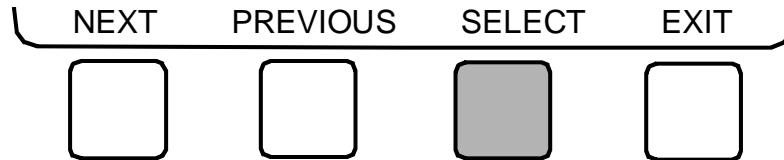
5. Press SELECT to enter the Data Table Select screen. This screen lists 18 holiday tables.



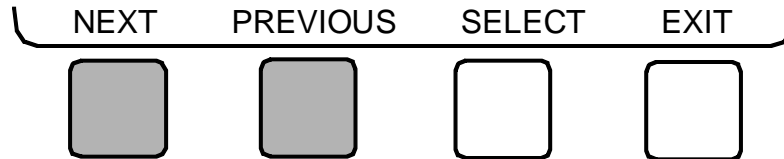
6. Press NEXT to highlight the holiday table that you wish to view or change. Each table is one holiday period, starting on a specific date, and lasting up to 99 days.



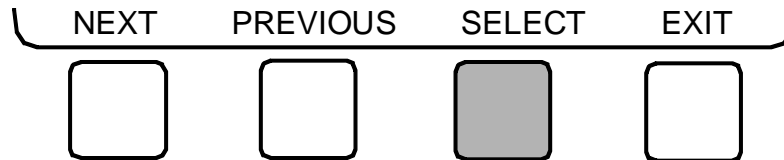
7. Press SELECT to access the holiday table. The Configuration Select table now shows the holiday start month and day, and how many days the holiday period will last.



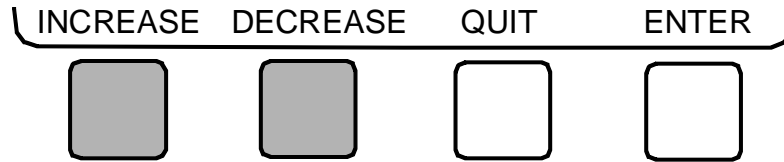
8. Press NEXT or PREVIOUS to highlight the month, day, or duration.



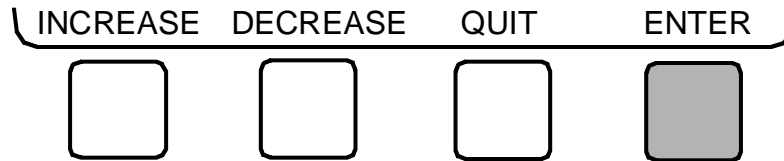
9. Press SELECT to modify the month, day, or duration.



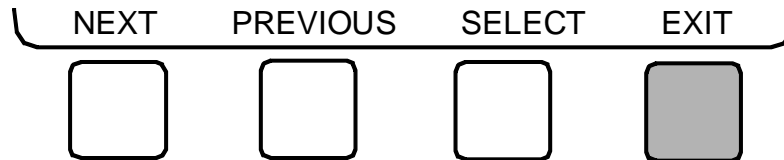
10. Press INCREASE or DECREASE to change the selected value.



11. Press ENTER to save the changes.



12. Press EXIT to return to the previous menu.



[Click here for Figure 23 — Example of Holiday Period Screen](#)



# Start-Up/Shutdown/Recycle Sequence (Figure 24)

## Local Start-Up

Local start-up (or a manual start-up) is initiated by pressing the LOCAL menu softkey which is on the default LID screen. Local start-up can proceed when Time Schedule 01 is in OCCUPIED mode, and after the internal 15 minute start-to-start and the 3 minute stop-to-start inhibit timers have expired (on PSIO software Version 08 and lower or a 1 minute stop-to-start timer on PSIO Software Version 09 and higher).

The chiller start/stop status point on the Status01 table may be overridden to start, regardless of the time schedule, in order to locally start the unit. Also, the remote contacts may be enabled through the LID and closed to initiate a start-up.

Whenever the chiller is in LOCAL control mode, the PIC will wait for Time Schedule 01 to become occupied and the remote contacts to close, if enabled. The PIC will then perform a series of pre-start checks to verify that all pre-start alerts and safeties are within the limits shown in [Table 3](#). The run status line on the LID now reads “Starting.” If the checks are successful, the chilled water/brine pump relay will be energized. Five seconds later, the condenser pump relay is energized. Thirty seconds later the PIC monitors the chilled water and condenser water flow switches, and waits until the *WATER FLOW VERIFY TIME* (operator configured, default 5 minutes) to confirm flow. After flow is verified, the chilled water/brine temperature is compared to *CONTROL POINT* plus *DEADBAND*. If the temperature is less



than or equal to this value, the PIC will turn off the condenser pump relay and go into a RECYCLE mode. If the water/brine temperature is high enough, the start-up sequence continues on to check the guide vane position. If the guide vanes are more than 6% open, the start-up waits until the PIC closes the vanes. If the vanes are closed, and the oil pump pressure is less than 3 psid (21 kPad), the oil pump relay will then be energized. The PIC then waits until the *OIL PRESS (Pressure) VERIFY TIME* (operator configured, default 15 seconds) for oil pressure to reach 18 psid (124 kPad). After oil pressure is verified, the PIC waits 10 seconds, and then the compressor start relay (1CR) is energized to start the compressor.

Failure to verify any of the requirements up to this point will result in the PIC aborting the start and displaying the applicable pre-start mode of failure on the LID default screen. A pre-start failure does not advance the starts in 12 hours counter. Any failure after the 1CR relay has energized results in a safety shutdown, advances the starts in the 12 hours counter by one, and displays the applicable shutdown status on the LID display.

[Click here for Figure 24 — Control Sequence](#)

## Shutdown Sequence

Shutdown of the machine can occur if any of the following events happen:

- the STOP button is pressed for at least one second (the alarm light will blink once to





- confirm stop command)
- recycle condition is present (see **Chilled Water Recycle Mode** section)
- time schedule has gone into UNOCCUPIED mode (machine protective limit has been reached and machine is in alarm)
- the start/stop status is overridden to stop from the CCN network or the LID

When a stop signal occurs, the shutdown sequence first stops the compressor by deactivating the start relay. A status message of “SHUTDOWN IN PROGRESS, COMPRESSOR DEENERGIZED” is displayed. The guide vanes are then brought to the closed position. The oil pump relay and the chilled water/brine pump relay are shut down 60 seconds after the compressor stops. The condenser water pump will be shut down when the *CONDENSER REFRIGERANT TEMP* is less than the *CONDENSER PRESSURE OVERRIDE* minus 5 psi (34 kPa) or is less than or equal to the *ENTERING CONDENSER WATER TEMP* plus 3° F (2° C). The stop-to-start timer will now begin to count down. If the start-to-start timer is still greater than the value of the start-to-stop timer, then this time is now displayed on the LID.

Certain conditions during shutdown will change this sequence:

- if the *COMPRESSOR MOTOR LOAD* is greater than 10% after shutdown, or the starter contacts remain energized, the oil pump and chilled water pump remain energized and the alarm is displayed
- if the *ENTERING CONDENSER WATER* temperature is greater than 115 F (46 C) at shutdown, the condenser pump will be deenergized after the 1CR compressor start relay



- if the machine shuts down due to low refrigerant temperature, the chilled water pump will stay running until the *LEAVING CHILLED WATER* is greater than *CONTROL POINT*, plus 5° F (3° C)

## **Automatic Soft Stop Amps Threshold (PSIO Software Version 09 and Higher)**

The SOFT STOP AMPS THRESHOLD closes the guide vanes of the compressor automatically when a non-recycle, non-alarm stop signal occurs before the compressor motor is deenergized.

If the STOP button is pressed, the guide vanes close to a preset amperage percent or until the guide vane is less than 2% open. The compressor will then shut off.

If the machine enters an alarm state or if the compressor enters a RECYCLE mode, the compressor will be deenergized immediately.

To activate SOFT STOP AMPS THRESHOLD, view the bottom of Service1 table. Set the SOFT STOP AMPS THRESHOLD value to the percentage amps at which the motor will shut down. The default setting is 100% amps (no Soft Stop).

When the SOFT STOP AMPS THRESHOLD is being applied, a status message “SHUTDOWN IN PROGRESS, COMPRESSOR UNLOADING” is shown.

## **Chilled Water Recycle Mode**

The machine may cycle off and wait until the load increases to restart again when the



compressor is running in a lightly loaded condition. This cycling of the chiller is normal and is known as recycle. A recycle shutdown is initiated when any of the following conditions are true:

- when in LCW control, the *LEAVING CHILLED WATER* temperature is more than 5° F (3° C) below the control point, and the *CONTROL POINT* has not increased in the last 5 minutes
- when *ECW CONTROL OPTION* is enabled, the *ENTERING CHILLED WATER* temperature is more than 5° F (3° C) below the *CONTROL POINT*, and the *CONTROL POINT* has not increased in the last 5 minutes
- when the *LEAVING CHILLED WATER* temperature is within 3° F (2° C) of the *BRINE REFRIG TRIPPOINT*.

When the machine is in RECYCLE mode, the chilled water pump relay remains energized so that the chilled water temperature can be monitored for increasing load. The recycle control uses *RECYCLE RESTART DELTA T* to check when the compressor should be restarted. This is an operator-configured function which defaults to 5° F (3° C). This value is viewed/modified on the Service1 table. The compressor will restart when:

- in LCW CONTROL the *LEAVING CHILLED WATER* temperature is greater than the *CONTROL POINT* plus the *RECYCLE RESTART DELTA T*; or
- in ECW CONTROL, the *ENTERING CHILLED WATER* temperature is greater than the *CONTROL POINT* plus the *RECYCLE RESTART DELTA T*

Once these conditions are met, the compressor shall initiate a start-up, with a normal start-up sequence.

An alert condition may be generated if 5 or more RECYCLE STARTUPS occur in less than 4



hours. This excessive recycling can reduce machine life. Compressor recycling due to extremely low loads should be reduced. To reduce compressor recycling, use the time schedule to shut the machine down during low load operation or increase the machine load by running the fan systems. If the hot gas bypass is installed, adjust the values to ensure that hot gas is energized during light load conditions. Increase the RECYCLE RESTART DELTA T on the Service1 table to lengthen the time between restarts.

The machine should not be operated below design minimum load without a hot gas bypass installed on the machine.

## **Safety Shutdown**

A safety shutdown is identical to a manual shutdown with the exception that the LID will display the reason for the shutdown, the alarm light will blink continuously, and the spare alarm contacts will be energized. A safety shutdown requires that the RESET softkey be pressed in order to clear the alarm. If the alarm is still present, the alarm light will continue to blink. Once the alarm is cleared, the operator must press the CCN or LOCAL softkeys to restart the machine.



**CAUTION**



**CAUTION**

**Do not reset starter loads or any other starter safety for 30 seconds after the compressor has stopped. Voltage output to the compressor start signal is maintained for 10 seconds to determine starter fault.**

## **Before Initial Start-Up**

### **Job Data Required**

- list of applicable design temperatures and pressures (product data submittal)
- machine certified prints
- starting equipment details and wiring diagrams
- diagrams and instructions for special controls or options
- 19XL Installation Instructions
- pumpout unit instructions

### **Equipment Required**

- mechanic's tools (refrigeration)
- digital volt-ohmmeter (DVM)
- clamp-on ammeter
- electronic leak detector



- absolute pressure manometer or wet-bulb vacuum indicator ([Figure 25](#))
- 500 v insulation tester (megohmmeter) for compressor motors with nameplate voltage of 600 v or less, or a 5000-v insulation tester for compressor motor rated above 600 v

## Using the Optional Storage Tank and Pumpout System

Refer to [Pumpout and Refrigerant Transfer Procedures](#) section for: pumpout system preparation, refrigerant transfer, and machine evacuation.

## Remove Shipping Packaging

Remove any packaging material from the control center, power panel, guide vane actuator, motor cooling and oil reclaim solenoids, motor and bearing temperature sensor covers, and the factory-mounted starter.

[Click here for Figure 25 — Typical Wet-Bulb Type Vacuum Indicator](#)

## Open Oil Circuit Valves

Check that the oil filter isolation valves ([Figure 4](#)) are open by removing the valve cap and checking the valve stem.

## Torque All Gasketed Joints

Gaskets normally have relaxed by the time the machine arrives at the jobsite. Tighten all gasketed joints to ensure a leak tight machine.



## Check Machine Tightness

Figure 26 outlines the proper sequence and procedures for leak testing.

19XL chillers are shipped with the refrigerant contained in the condenser shell and the oil charge shipped in the compressor. The cooler will have a 15 psig (103 kPa) refrigerant charge. Units may be ordered with the refrigerant shipped separately, along with a 15 psig (103 kPa) nitrogen-holding charge in each vessel. To determine if there are any leaks, the machine should be charged with refrigerant. Use an electronic leak detector to check all flanges and solder joints after the machine is pressurized. If any leaks are detected, follow the leak test procedure.

If the machine is spring isolated, keep all springs blocked in both directions in order to prevent possible piping stress and damage during the transfer of refrigerant from vessel to vessel during the leak test process, or any time refrigerant is transferred. Adjust the springs when the refrigerant is in operating condition, and when the water circuits are full.

## Refrigerant Tracer

Carrier recommends the use of an environmentally acceptable refrigerant tracer for leak testing with an electronic detector or halide torch.

Ultrasonic leak detectors also can be used if the machine is under pressure.



**WARNING**



**WARNING**

**Do not use air or oxygen as a means of pressurizing the machine. Some mixtures of HCFC-22 or HFC-134a and air can undergo combustion.**

[Click here for Figure 26 — 19XL Leak Test Procedures](#)

## **Leak Test Machine**

Due to regulations regarding refrigerant emissions and the difficulties associated with separating contaminants from refrigerant, Carrier recommends the following leak test procedures. See [Figure 26](#) for an outline of the leak test procedures. Refer to [Figure 27](#) and [Figure 28](#) during pumpout procedures and [Table 5A](#), [Table 5B](#), [Table 5C](#), and [Table 5D](#) for refrigerant pressure/temperature values.

1. If the pressure readings are normal for machine condition:
  - a. Evacuate the holding charge from the vessels, if present.
  - b. Raise the machine pressure, if necessary, by adding refrigerant until pressure is at equivalent saturated pressure for the surrounding temperature. Follow the pumpout procedures in the [Transferring Refrigerant from Storage Tank to Machine](#) section, Steps 1a - e.



**WARNING**



**WARNING**

**Never charge liquid refrigerant into the machine if the pressure in the machine is less than 68 psig (469 kPa) for HCFC-22 and 35 psig (241 kPa) for HFC-134a. Charge as a gas only, with the cooler and condenser pumps running, until this pressure is reached, using PUMPDOWN LOCKOUT and TERMINATE LOCKOUT mode on the PIC. Flashing of liquid refrigerant at low pressures can cause tube freezeup and considerable damage.**

- c. Leak test machine as outlined in Steps 3 - 9.
2. If the pressure readings are abnormal for machine condition:
- a. Prepare to leak test machines shipped with refrigerant (Step 2h).
  - b. Check for large leaks by connecting a nitrogen bottle and raising the pressure to 30 psig (207 kPa). Soap test all joints. If the test pressure holds for 30 minutes, prepare the test for small leaks (Steps 2g - h).
  - c. Plainly mark any leaks which are found.
  - d. Release the pressure in the system.
  - e. Repair all leaks.
  - f. Retest the joints that were repaired.





- b. If the machine fails this test, check for large leaks (Step 2b).
  - c. Dehydrate the machine if it passes the standing vacuum test. Follow the procedure in the Machine Dehydration section. Charge machine with refrigerant (see Pumpout and Refrigerant Transfer Procedures, [Machines with Storage Tanks](#) section, Steps 1a-e).
7. If a leak is found, pump the refrigerant back into the storage tank, or if isolation valves are present, pump into the non-leaking vessel (see [Pumpout and Refrigerant Transfer Procedures](#) section).
  8. Transfer the refrigerant until machine pressure is at 18 in. Hg (40 kPa absolute).
  9. Repair the leak and repeat the procedure, beginning from Step 2h to ensure a leaktight repair. (If machine is opened to the atmosphere for an extended period, evacuate it before repeating leak test.)

## Standing Vacuum Test

When performing the standing vacuum test, or machine dehydration, use a manometer or a wet bulb indicator. Dial gages cannot indicate the small amount of acceptable leakage during a short period of time.

1. Attach an absolute pressure manometer or wet bulb indicator to the machine.
2. Evacuate the vessel (see [Pumpout and Refrigerant Transfer Procedures](#) section) to at least 18 in. Hg vac, ref 30-in. bar (41 kPa), using a vacuum pump or the pumpout unit.
3. Valve off the pump to hold the vacuum and record the manometer or indicator reading.



4.

- a. If the leakage rate is less than 0.05 in. Hg (.17 kPa) in 24 hours, the machine is sufficiently tight.
- b. If the leakage rate exceeds 0.05 in. Hg (.17 kPa) in 24 hours, repressurize the vessel and test for leaks. If refrigerant is available in the other vessel, pressurize by following Steps 2-10 of [Return Refrigerant to Normal Operating Conditions](#) section. If not, use nitrogen and a refrigerant tracer. Raise the vessel pressure in increments until the leak is detected. If refrigerant is used, the maximum gas pressure is approximately 120 psig (827 kPa) for HCFC-22, 70 psig (483 kPa) for HFC-134a at normal ambient temperature. If nitrogen is used, limit the leak test pressure to 230 psig (1585 kPa) maximum.

5. Repair leak, retest, and proceed with dehydration.

[Click here for Figure 27 — Typical Optional Pumpout System Piping Schematic with Storage Tank](#)

[Click here for Figure 28 — Typical Optional Pumpout System Piping Schematic without Storage Tank](#)



[Click here for Table 5A — HCFC-22 Pressure — Temperature \(F\)](#)

[Click here for Table 5B — HCFC-22 Pressure — Temperature \(C\)](#)

[Click here for Table 5C — HFC-134a Pressure — Temperature \(F\)](#)

[Click here for Table 5D — HFC-134a Pressure — Temperature \(C\)](#)

## **Machine Dehydration**

Dehydration is recommended if the machine has been open for a considerable period of time, if the machine is known to contain moisture, or if there has been a complete loss of machine holding charge or refrigerant pressure.



**WARNING**



**WARNING**

**Do not start or megohm test the compressor motor or oil pump motor, even for a rotation check, if the machine is under dehydration vacuum. Insulation breakdown and severe damage may result.**

Dehydration is readily accomplished at room temperatures. Use of a cold trap (Figure 29) may substantially reduce the time required to complete the dehydration. The higher the room temperature, the faster dehydration takes place. At low room temperatures, a very deep vacuum is required for boiling off any moisture. If low ambient temperatures are involved, contact a qualified service representative for the dehydration techniques required.

Perform dehydration as follows:

1. Connect a high capacity vacuum pump (5 cfm [ $.002 \text{ m}^3/\text{s}$ ] or larger is recommended) to the refrigerant charging valve (Figure 2A or Figure 2B). Tubing from the pump to the machine should be as short and as large a diameter as possible to provide least resistance to gas flow.
2. Use an absolute pressure manometer or a wet bulb vacuum indicator to measure the vacuum. Open the shutoff valve to the vacuum indicator only when taking a reading. Leave the valve open for 3 minutes to allow the indicator vacuum to equalize with the machine vacuum.



3. Open all isolation valves (if present), if the entire machine is to be dehydrated.
4. With the machine ambient temperature at 60 F (15.6 C) or higher, operate the vacuum pump until the manometer reads 29.8 in. Hg vac, ref 30 in. bar. (0.1 psia) (−100.61 kPa) or a vacuum indicator reads 35 F (1.7 C). Operate the pump an additional 2 hours.  
Do not apply greater vacuum than 29.82 in. Hg vac (757.4 mm Hg) or go below 33 F (.56 C) on the wet bulb vacuum indicator. At this temperature/pressure, isolated pockets of moisture can turn into ice. The slow rate of evaporation (sublimation) of ice at these low temperatures/ pressures greatly increases dehydration time.
5. Valve off the vacuum pump, stop the pump, and record the instrument reading.
6. After a 2-hour wait, take another instrument reading. If the reading has not changed, dehydration is complete. If the reading indicates vacuum loss, repeat Steps 4 and 5.
7. If the reading continues to change after several attempts, perform a leak test up to the maximum 230 psig (1585 kPa) pressure. Locate and repair the leak, and repeat dehydration.

[Click here for Figure 29 — Dehydration Cold Trap](#)



## Inspect Water Piping

Refer to piping diagrams provided in the certified drawings, and the piping instructions in the 19XL Installation Instructions manual. Inspect the piping to the cooler and condenser. Be sure that flow directions are correct and that all piping specifications have been met.

Piping systems must be properly vented, with no stress on waterbox nozzles and covers. Water flows through the cooler and condenser must meet job requirements. Measure the pressure drop across cooler and across condenser.

**CAUTION**



**CAUTION**

**Water must be within design limits, clean, and treated to ensure proper machine performance and reduce the potential of tubing damage due to corrosion, scaling, or erosion. Carrier assumes no responsibility for chiller damage resulting from untreated or improperly treated water.**

## Check Optional Pumpout Compressor Water Piping

If the optional storage tank and/or pumpout system are installed, check to ensure the pumpout condenser water has been piped in. Check for field-supplied shutoff valves and controls as specified in the job data. Check for refrigerant leaks on field-installed piping. See

[Figure 27](#) and [Figure 28](#).





## Check Relief Devices

Be sure that relief devices have been piped to the outdoors in compliance with the latest edition of ANSI/ASHRAE Standard 15 and applicable local safety codes. Piping connections must allow for access to the valve mechanism for periodic inspection and leak testing.

19XL relief valves are set to relieve at the 300 psig (2068 kPa) machine design pressure.

## Inspect Wiring

**WARNING**



**WARNING**

**Do not check voltage supply without proper equipment and precautions. Serious injury may result. Follow power company recommendations.**

**CAUTION**



**CAUTION**

**Do not apply any kind of test voltage, even for a rotation check, if the machine is under a dehydration vacuum. Insulation breakdown and serious damage may result.**

1. Examine wiring for conformance to job wiring diagrams and to all applicable electrical codes.



2. On low-voltage compressors (600 v or less) connect voltmeter across the power wires to the compressor starter and measure the voltage. Compare this reading with the voltage rating on the compressor and starter nameplates.
3. Compare the ampere rating on the starter nameplate with the compressor nameplate. The overload trip amps must be 108% to 120% of the rated load amps.
4. The starter for a centrifugal compressor motor must contain the components and terminals required for PIC refrigeration control. Check certified drawings.
5. Check the voltage to the following components and compare to the nameplate values: oil pump contact, pumpout compressor starter, and power panel.
6. Be sure that fused disconnects or circuit breakers have been supplied for the oil pump, power panel, and pumpout unit.
7. Check that all electrical equipment and controls are properly grounded in accordance with job drawings, certified drawings, and all applicable electrical codes.
8. Make sure that the customer's contractor has verified proper operation of the pumps, cooling tower fans, and associated auxiliary equipment. This includes ensuring that motors are properly lubricated and have proper electrical supply and proper rotation.
9. For field-installed starters only, test the machine compressor motor and its power lead insulation resistance with a 500-v insulation tester such as a megohmmeter. (Use a 5000-v tester for motors rated over 600 v.) Factory-mounted starters do not require a megohm test.



- a. Open the starter main disconnect switch and follow lockout/tagout rules.

**CAUTION**



**CAUTION**

**If the motor starter is a solid-state starter, the motor leads must be disconnected from the starter before an insulation test is performed. The voltage generated from the tester can damage the starter solid-state components.**

- b. With the tester connected to the motor leads, take 10-second and 60-second megohm readings as follows:

6-Lead Motor — Tie all 6 leads together and test between the lead group and ground. Next tie leads in pairs, 1 and 4, 2 and 5, and 3 and 6. Test between each pair while grounding the third pair.

3-Lead Motor — Tie terminals 1, 2, and 3 together and test between the group and ground.

- c. Divide the 60-second resistance reading by the 10-second reading. The ratio, or polarization index, must be one or higher. Both the 10- and 60-second readings must be at least 50 megohms.

If the readings on a field-installed starter are unsatisfactory, repeat the test at the motor with the power leads disconnected. Satisfactory readings in this second test indicate the fault is in the power leads.



**Note:** Unit-mounted starters do not have to be megohm tested.

10. Tighten up all wiring connections to the plugs on the SMM, 8-input, and PSIO modules.
11. Ensure that the voltage selector switch inside the power panel is switched to the incoming voltage rating.
12. On machines with freestanding starters, inspect the power panel to ensure that the contractor has fed the wires into the bottom of the panel. Wiring into the top of the panel can cause debris to fall into the contactors. Clean and inspect the contactors if this has occurred.

## Carrier Comfort Network Interface

The Carrier Comfort Network (CCN) communication bus wiring is supplied and installed by the electrical contractor. It consists of shielded, 3-conductor cable with drain wire.

The system elements are connected to the communication bus in a daisy chain arrangement. The positive pin of each system element communication connector must be wired to the positive pins of the system element on either side of it; the negative pins must be wired to the negative pins; the signal ground pins must be wired to signal ground pins.

To attach the CCN communication bus wiring, refer to the certified drawings and wiring diagrams. The wire is inserted into the CCN communications plug (COMM1) on the PSIO module. This plug also is referred to as J5.

**Note:** Conductors and drain wire must be 20 AWG (American Wire Gage) minimum stranded,



tinned copper. Individual conductors must be insulated with PVC, PVC/nylon, vinyl, Teflon, or polyethylene. An aluminum/polyester 100% foil shield and an outer jacket of PVC, PVC/nylon, chrome vinyl or Teflon with a minimum operating temperature range of -20 C to 60 C is required. See table below for cables that meet the requirements.

<b>Manufacturer</b>	<b>Cable No.</b>
<b>Alpha</b>	2413 or 5463
<b>American</b>	A22503
<b>Belden</b>	8772
<b>Columbia</b>	02525

When connecting the CCN communication bus to a system element, a color code system for the entire network is recommended to simplify installation and checkout. The following color code is recommended:

<b>Signal Type</b>	<b>CCN Bus Conductor Insulation Color</b>	<b>PSIO Module Comm 1 Plug (J5) Pin No.</b>
<b>+</b>	RED	1
<b>Ground</b>	WHITE	2
<b>-</b>	BLACK	3



## Check Starter

**CAUTION**



**CAUTION**

**BE AWARE** that certain automatic start arrangements *can engage the starter*. Open the disconnect *ahead* of the starter in addition to shutting off the machine or pump.

Use the instruction and service manual supplied by the starter manufacturer to verify that the starter has been installed correctly.

**CAUTION**



**CAUTION**

**The main disconnect on the starter front panel may not deenergize all internal circuits. Open all internal and remote disconnects before servicing the starter.**

Whenever a starter safety trip device activates, wait at least 30 seconds before resetting the safety. The microprocessor maintains its output to the 1CR relay for 10 seconds to determine the fault mode of failure.

## Mechanical-Type Starters

1. Check all field wiring connections for tightness, clearance from moving parts, and correct connection.
2. Check the contactor(s) to be sure they move freely. Check the mechanical interlock between contactors to ensure that 1S and 2M contactors cannot be closed at the same time. Check all other electro-mechanical devices, e.g., relays, timers, for free movement. If the devices do not move freely, contact the starter manufacturer for replacement components.
3. Some dashpot-type magnetic overload relays must be filled with oil on the job site. If the starter is equipped with devices of this type, remove the fluid cups from these magnetic overload relays. Add dashpot oil to cups per instructions supplied with the starter. The oil is usually shipped in a small container attached to the starter frame near the relays. Use only dashpot oil supplied with the starter. Do not substitute.

Factory-filled dashpot overload relays need no oil at start-up and solid-state overload relays do not have oil.

4. Reapply starter control power (*not main chiller power*) to check electrical functions. When using a reduced-voltage starter (such as a wye-delta type) check the transition timer for proper setting. The factory setting is 30 seconds ( $\pm 5$  seconds), timed closing. The timer is adjustable in a range between 0 and 60 seconds and settings other than the nominal 30



seconds may be chosen as needed (typically 20 to 30 seconds are used).

When the timer has been set, check that the starter, (with relay 1CR closed, goes through a complete and proper start cycle.

## Benshaw, Inc. Solid-State Starter

**WARNING**



**WARNING**

**This equipment is at line voltage when AC power is connected. Pressing the STOP button does not remove voltage. Use caution when adjusting the potentiometers on the equipment.**

1. Check that all wiring connections are properly terminated to the starter.
2. Verify that the ground wire to the starter is installed properly and is of sufficient size.
3. Verify that the motors are properly grounded to the starter.
4. Check that all of the relays are properly seated in their sockets.
5. Verify that the proper ac input voltage is brought into the starter per the certified drawings.
6. Verify the initial factory settings of the starting torque and ramp potentiometers are set per the note on the schematic for the starters.

**Note:** The potentiometers are located at the lower left hand corner on the circuit board mounted in front of the starter power stack ([Figure 30](#) and [Figure 31](#)).





The starting torque potentiometer should be set so that when the PIC calls for the motor to start, the rotor should just start to turn. The nominal dial position for a 60 Hz motor is approximately the 11:30 position. The nominal dial position for a 50 Hz motor is approximately in the 9:30 position because the board is turned on its side, so that the 9:00 o'clock position is located where the 6:00 o'clock position would normally be located. The ramp potentiometer should be set so that the motor is up to full speed in 15 to 20 seconds, the bypass contactors have energized, and the auxiliary LCD is energized.

7. Proceed to apply power to the starter.
8. The Power +15 and Phase Correct LEDs should be on. If not, see the starter [Troubleshooting Guide](#) section.

[Click here for Figure 30 — Benshaw, Inc. Solid-State Starter Power Stack](#)

[Click here for Figure 31 — Ramp Up and Starting Torque Potentiometers](#)



# Initial Start-Up Checklist for 19XL Hermetic Centrifugal Liquid Chiller

(Print and use for job file)

[Click here for Initial Start-Up Checklist for 19XL Hermetic Centrifugal Liquid Chiller](#)

## Cutler-Hammer® Solid-State Starters

**WARNING**



**WARNING**

**This equipment is at line voltage when ac power is connected. Pressing the STOP button does not remove voltage. Use caution when adjusting the potentiometers on the equipment.**

1. Check that all wiring connections are properly terminated to the starter.
2. Verify that the ground wire to the starter is installed properly and is of sufficient size.
3. Verify that the motor is properly grounded to the starter.
4. Check that all of the relays are properly seated in their sockets.
5. Verify that the proper ac input voltage is brought into the starter. Refer to the certified drawings.

The order in which the solid-state control module adjustment potentiometers are set is



important because of the interdependency of these functions. See [Table 6](#). The settings should be made in the following sequence:

### Potentiometer Adjustment

**Note:** All potentiometers are factory set. The following information is provided for reference.

Adjustment potentiometers are nearly linear. To make an initial setting, determine the percentage of the potentiometer rotation. Use the following formula to calculate the percent of rotation. See [Figure 32](#) and [Figure 33](#).

$$\% \text{ of rotation} = \frac{(\text{desired setting}) - (\text{minimum setting})}{(\text{maximum setting}) - (\text{minimum setting})}$$

Example: Starting current is adjustable between 100% and 400% of motor full load current. The initial setting for 200% starting current is as follows:

$$\% \text{ of rotation} = \frac{(200\%) - (100\%)}{(400\%) - (100\%)} = 1/3 \text{ of full rotation (33\%)}$$



**CAUTION**



**CAUTION**

**Do not adjust any potentiometer beyond its stops. This type of adjustment will result in damage to the potentiometer.**

## Starting Current

The torque required to start a machine (initial torque) varies from one application to another. Starting current may be adjusted to match the initial motor torque of the application. The starting current value is adjustable from 100% to 400% FLA and is factory set at 100%. If quick acceleration is desired, set the starting current at a higher level.

[Click here for Table 6 — Potentiometer Adjustment](#)

[Click here for Figure 32 — Typical Potentiometer Adjustment](#)

[Click here for Figure 33 — Typical Cutler-Hammer® Solid State Starter](#)



## **Ramp Time (Adjustable Current Ramp)**

The motor current is ramped up from the starting current value over a timed period set by the ramp time potentiometer (adjustable from 2 to 30 seconds at 400% current limit setting). The 19XL is factory set at 15 seconds. However, based on jobsite conditions, a range of  $\pm 5$  seconds is acceptable.

## **Current Limit**

This protection limits motor current to a set value and holds motor torque at a reduced level during motor start. The current limit is adjustable from 100% to 400% of the motor full load current value. The current limit is factory set at 250%.

## **Pulse Start**

A pulse start is not used on this machine. It is set to the OFF position.

## **Current Trip**

A control contact closes when the motor reaches a factory set value of 175% of full load amps. This signal is used as an interlock to shut down the machine if the motor stalls (increasing load).

## **Changing Adjustments**

The settings are interdependent. If any setting is changed, the other settings should be checked. Check the settings in the sequence shown above.



## Voltage Measurements

Consider the following when checking voltage measurements:

- Before energizing the starter, check the incoming lines for properly balanced voltages.
- Close the circuit breaker to apply power to the starter. Verify the 120 vac control voltage.
- Visually check to ensure that all fans are running (if applicable).
- Verify phase sequence at line terminals. Incorrect phase sequence will result in a shunt trip of the circuit breaker.
- Verify that the phase rotation of the lines to the motor is correct.
- If the motor is found to be rotating in the wrong direction, interchange any two phases to the motor.
- Start the unit.
- When unit reaches full speed, monitor the running current to ensure that the motor is not overloaded.

## Oil Charge

The 19XL compressor holds approximately 8 gal. (30 L) of oil. The machine will be shipped with oil in the compressor. When the sump is full, the oil level should be no higher than the middle of the upper sight glass and minimum level is the bottom of the lower sight glass ([Figure 2A](#) or [Figure 2B](#)). If oil is added, it must meet Carrier's specification for centrifugal compressor usage as described in the [Oil Changes](#) section. Charge the oil through the oil charging valve,



located near the bottom of the transmission housing ([Figure 2A](#) or [Figure 2B](#)). The oil must be pumped from the oil container through the charging valve due to higher refrigerant pressure. The pumping device must be able to lift from 0 to 200 psig (0 to 1380 kPa) or above unit pressure. Oil should only be charged or removed when the machine is shut down.

## **Power Up the Controls and Check the Oil Heater**

Ensure that an oil level is visible in the compressor before energizing controls. A circuit breaker in the starter energizes the oil heater and the control circuit. When first powered, the LID should display the default screen within a short period of time.

The oil heater is energized by powering the control circuit. This should be done several hours before start-up to minimize oil-refrigerant migration. The oil heater is controlled by the PIC and is powered through a contactor in the power panel. Starters contain a separate circuit breaker to power the heater and the control circuit. This set up allows the heater to energize when the main motor circuit breaker is off for service work or extended shutdowns. The oil heater relay status can be viewed on the Status02 table on the LID. Oil sump temperature can be viewed on the LID default screen.

When the Time/Date is configured for the first time or if power is lost for more than 3 hours, the oil heater will be energized until the oil temperature is at least 100° F (55° C) above the evaporator temperature. See the [Oil Sump Temperature Control](#) section for additional information. The oil pump will then energize for 1 to 2 minutes to bring the oil temperature to



normal operating temperature. A LOW OIL TEMPERATURE alert will show on the default LID screen if the operator has the controls set to start.

## Software Version

The software version will always be labeled on the PSIO module, and on the back side of the LID module. On both the Controller ID and LID ID display screens, the software version number will also appear.

## Set Up Machine Control Configuration

**WARNING**



**WARNING**

**Do not operate the machine before the control configurations have been checked and a Control Test has been satisfactorily completed. Protection by safety controls cannot be assumed until all control configurations have been confirmed.**

As configuration of the 19XL unit is performed, write down all configuration settings. A log, such as the one shown on pages CL-1 to CL-2, provides a convenient list for configuration values.





## Input the Design Set Points

Access the LID set point screen and view/modify the base demand limit set point, and *either* the LCW set point *or* the ECW set point. The PIC can control a set point to either the leaving or entering chilled water. This control method is set in the Equipment Configuration table, Config table.

## Input the Local Occupied Schedule (OCCPC01S)

Access the schedule OCCPC01S screen on the LID and set up the occupied time schedule per the customer's requirements. If no schedule is available, the default is factory set for 24 hours occupied 7 days per week including holidays.

For more information about how to set up a time schedule, see the [Controls](#) section.

The CCN Occupied Schedule (OCCPC03S) should be configured if a CCN system is being installed or if a secondary time schedule is needed.

## Selecting Refrigerant Type

The 19XL control must be configured for the refrigerant being used, either HCFC-22 or HFC-134a.

## To Confirm Refrigerant Type

Confirm that the correct refrigerant type is indicated by entering the Controls Test tables on the Service menu, [Figure 17](#). Select REFRIGERANT TYPE. The screen will display the current



refrigerant setting. Press EXIT softkey to leave the screen without changes.

## To Change Refrigerant Type

Enter the Controls Test tables on the Service Menu. See [Figure 17](#). Select REFRIGERANT TYPE. The screen will display the current refrigerant setting. Press YES softkey to change the current setting. Next, move to the ATTACH TO NETWORK DEVICE screen on the Service menu and the ATTACH TO LOCAL DEVICE to upload the new refrigerant tables.

## Input Service Configurations

The following configurations require the LID screen to be in the Service portion of the menu.

- password
- input time and date
- LID configuration
- controller identification
- service parameters
- equipment configuration
- automated control test

## Password

When accessing the Service tables, a password must be entered. All LIDs are initially set for a password of 1-1-1-1. This password may be changed in the LID configuration screen, if desired.



## **Input Time and Date**

Access the Time and Date table on the Service menu. Input the present time of day, date, and day of the week. “Holiday Today” should only be configured to “Yes” if the present day is a holiday.

## **Change Lid Configuration If Necessary**

The LID Configuration screen is used to view or modify the LID CCN address, change to English or SI units, and to change the password. If there is more than one machine at the jobsite, change the LID address on each machine so that each machine has its own address. Note and record the new address. Change the screen to SI units as required, and change the password if desired.

## **Modify Controller Identification If Necessary**

The controller identification screen is used to change the PSIO module address. Change this address for each machine if there is more than one machine at the jobsite. Write the new address on the PSIO module for future reference.

Change the LID address if there is more than one machine on the jobsite. Access the LID configuration screen to view or modify this address.

## **Input Equipment Service Parameters If Necessary**

The Equipment Service table has three service tables: Service1, Service2, and Service3.



## Configure SERVICE1 Table

Access Service1 table to modify/view the following to jobsite parameters:

<b>Chilled Medium Brine Refrigerant Trippoint Surge Limiting or Hot Gas Bypass Option Minimum Load Points (T1/P1) Maximum Load Points (T2/P2) Amps Correction Factor Motor Rated Load Amps Motor Rated Line Voltage Motor Rated Line kW Line Frequency Compressor Starter Type</b>	Water or Brine? Usually 3° F (1.7° C) below design refrigerant temperature Is HGBP installed?  Per job data — See Modify Load Points section (this page) Per job data — See Modify Load Points section (this page) See <a href="#">Table 6</a> Per job data Per job data Per job data (if kW meter installed) 50 or 60 Hz Reduced voltage or full?
--	---

**Note:** Other values are left at the default values. These may be changed by the operator as required. Service2 and Service3 tables can be modified by the owner/operator as required.

### Modify Minimum and Maximum Load Points ( $\Delta T1/P1$ ; $\Delta T2/P2$ ) If Necessary

These pairs of machine load points, located on the Service1 table, determine when to limit guide vane travel or to open the hot gas bypass valve when surge prevention is needed. These points should be set based on individual machine operating conditions.



If, after configuring a value for these points, surge prevention is operating too soon or too late for conditions, these parameters should be changed by the operator.

Example of configuration: Machine operating parameters

Refrigerant used: HCFC-22

*Estimated Minimum Load Conditions:*

44 F (6.7 C) LCW

45.5 F (7.5 C) EWC

43 F (6.1 C) Suction Temperature

70 F (21.1 C) Condensing Temperature

*Estimated Maximum Load Conditions:*

44 F (6.7 C) LCW

54 F (12.2 C) ECW

42 F (5.6 C) Suction Temperature

98 F (36.7 C) Condensing Temperature



## Calculate Maximum Load

To calculate maximum load points, use design load condition data. If the machine full load cooler temperature difference is more than 15° F (8.3 C), estimate the refrigerant suction and condensing temperatures at this difference. Use the proper saturated pressure and temperature for the particular refrigerant used.

Suction Temperature:

42 F (5.6 C) = 71.5 psig (521 kPa) saturated refrigerant pressure (HCFC-22)

Condensing Temperature:

98 F (36.7 C) = 190 psig (1310 kPa) saturated refrigerant pressure (HCFC-22)

Maximum Load  $\Delta T_2$ :

54 – 44 = 10° F (12.2 – 6.7 = 5.5° C)

Maximum Load  $\Delta P_2$ :

190 – 71.5 = 118.5 psid (1310 – 521 = 789 kPad)

To avoid unnecessary surge prevention, add about 10 psid (70 kPad) to  $\Delta P_2$  from these conditions:

$\Delta T_2 = 10^\circ \text{ F (5.5}^\circ \text{ C)}$

$\Delta P_2 = 130 \text{ psid (900 kPad)}$



## Calculate Minimum Load

To calculate minimum load conditions, estimate the temperature difference that the cooler will have at 10% load, then estimate what the suction and condensing temperatures will be at this point. Use the proper saturated pressure and temperature for the particular refrigerant used.

Suction Temperature:

43 F (6.1 C) = 73 psig (503 kPa) saturated refrigerant pressure (HCFC-22)

Condensing Temperature:

70 F (21.1 C) = 121 psig (834 kPa) saturated refrigerant pressure (HCFC-22)

Minimum Load  $\Delta T1$ :

$45.5 - 44 = 1.5^\circ \text{ F}$  ( $7.5 - 6.7 = 0.8^\circ \text{ C}$ )

Minimum Load  $\Delta P1$ :

$121 - 73 = 48 \text{ psid}$  ( $834 - 503 = 331 \text{ kPad}$ )

Again, to avoid unnecessary surge prevention, add 10 psid (70 kPad) at  $\Delta P1$  from these conditions:

$\Delta T1 = 1.5 \text{ F}$  (0.8 C)

$\Delta P1 = 60 \text{ psid}$  (410 kPad)



If surge prevention occurs too soon or too late:

Load	Surge Prevention Occurs Too Soon	Surge Prevention Occurs Too Late
At low loads (<50%)	Increase P1 by 10 psid (70 kPad)	Decrease P1 by 10 psid (70 kPad)
At high loads (>50%)	Increase P2 by 10 psid (70 kPad)	Decrease P2 by 10 psid (70 kPad)

## Modify Amp Correction Factors

To modify the amp correction factor, use the values listed in [Table 7](#). Enter the appropriate amp correction factor in the Service1 table of Equipment Service.

[Click here for Table 7 — Amps Correction Factors for 19XL Motors](#)

## Modify Equipment Configuration If Necessary

The Equipment Configuration table has tables to select and view or modify. Carrier's certified drawings will have the configuration values required for the jobsite. Modify these tables only if requested.





## Config Table Modifications

Change the values in this table per job data. See certified drawings for values. Modifications include:

- chilled water reset
- entering chilled water control (Enable/Disable)
- 4-20 mA demand limit
- auto restart option (Enable/Disable)
- remote contact option (Enable/Disable)

## Owner-Modified CCN Tables

The following tables are described for reference only.

*Occdef Table Modifications* — The Occdef tables contain the Local and CCN time schedules, which can be modified here, or in the Schedule screen as described previously.

*Holidef Table Modifications* —The Holidef tables configure the days of the year that holidays are in effect. See the holiday paragraphs in the **Controls** section for more details.

*Brodef's Table Modifications* — The Brodef's screen defines the outside-air temperature sensor and humidity sensor if one is to be installed. It will define the start and end of daylight savings time. Enter the dates for the start and end of daylight savings if required for the location. Brodef's also will activate the Broadcast function which enables the holiday periods that are defined on the LID.

*Other Tables* —The Alarmdef, Cons-def, and Runt-def contain tables for use with a CCN



system. See the applicable CCN manual for more information on these tables. These tables can only be defined through a CCN Building Supervisor.

## Check Voltage Supply

Access the Status 01 screen and read the actual line voltage. This reading should be equal to the incoming power to the starter. Use a voltmeter to check incoming power at the starter power leads. If the readings are not equal, an adjustment can be made to the 24-v input to the SMM at the potentiometer located in the low-voltage section to equalize the two readings.

## Perform an Automated Control Test

Check the safety controls status by performing an automated controls test. Access the Control Test table and select the Automated Tests function ([Table 8](#)).

The Automated Control Test will check all outputs and inputs for function. It will also set the refrigerant type. The compressor must be in the OFF mode in order to operate the controls test and the 24-v input to the SMM must be in range (per line voltage percent on Status01 table). The OFF mode is caused by pressing the STOP pushbutton on the LID. Each test will ask the operator to confirm that the operation is occurring, and whether or not to continue. If an error occurs, the operator has the choice to try to address the problem as the test is being done, or to note the problem and proceed to the next test.

**Note:** If during the Control Test the guide vanes do not open, check to see that the low pressure alarm is not active. (This will cause the guide vanes to close).



**Note:** The oil pump test will not energize the oil pump if cooler pressure is below –5 psig (–35 kPa).

When the test is finished, or the EXIT softkey is pressed, the test will be stopped and the Control Test menu will be displayed. If a specific automated test procedure is not completed, access the particular control test to test the function when ready. The Control Test menu is described as follows.

<b>Automated Tests</b>	As described above, a complete control test.
<b>PSIO Thermistors</b>	Check of all PSIO thermistors only.
<b>Options Thermistors</b>	Check of all options boards thermistors.
<b>Transducers</b>	Check of all transducers.
<b>Guide Vane Actuator</b>	Check of the guide vane operation.
<b>Pumps</b>	Check operation of pump outputs, either all pumps can be activated, or individual pumps. The test will also test the associated input such as flow or pressure.
<b>Discrete Outputs</b>	Activation of all on/off outputs or individually.
<b>Pumpdown/Lockout</b>	Pumpdown prevents the low refrigerant alarm during evacuation so refrigerant can be removed from the unit; locks the compressor off; and starts the water pumps.
<b>Terminate Lockout</b>	To charge refrigerant and enable the chiller to run after pumpdown lockout.
<b>Refrigerant Type*</b>	Sets type of refrigerant used: HCFC-22 or HFC-134a.

\*Make sure to Attach to Local Device after changing refrigerant type. Refer to [Selecting Refrigerant Type](#) section.



## Check Optional Pumpout System Controls and Compressor

Controls include an on/off switch, a 3-amp fuse, the compressor overloads, an internal thermostat, a compressor contactor, and a refrigerant high pressure cutout. The high pressure cutout is factory set to open at  $220 \pm 5$  psig ( $1250 \pm 34$  kPa), and automatically reset at  $185 +0, -7$  ( $1280 +0, -48$  kPa) with HCFC-22. HFC-134a units open at 161 psig (1110 kPa) and reset at 130 psig (896 kPa). Check that the water-cooled condenser has been connected. Loosen the compressor holddown bolts to allow free spring travel. Open the compressor suction and discharge service valves. Check that oil is visible in the compressor sight glass. Add oil if necessary.

See [Pumpout and Refrigerant Transfer Procedures](#) and [Optional Pumpout System Maintenance](#) sections, for details on transfer of refrigerant, oil specifications, etc.

## High Altitude Locations

Recalibration of the pressure transducers will be necessary as the machine was initially calibrated at sea level. Please see the calibration procedure in the [Troubleshooting Guide](#) section.



## Charge Refrigerant into Machine

**CAUTION**



**CAUTION**

The transfer, addition, or removal of refrigerant in spring isolated machines may place severe stress on external piping if springs have not been blocked in both up and down directions.

The standard 19XL machine will have the refrigerant already charged in the vessels. The 19XL may be ordered with a nitrogen holding charge of 15 psig (103 kPa). Evacuate the entire machine, and charge machine from refrigerant cylinders.

### 19XL Machine Equalization without Pumpout Unit

**WARNING**



**WARNING**

When equalizing refrigerant pressure on the 19XL machine after service work or during the initial machine start-up, *do not use the discharge isolation valve to equalize*. The motor cooling isolation valve or charging hose (connected between pumpout valves on top of cooler and condenser) is to be used as the equalization valve.



To equalize the pressure differential on a refrigerant isolated 19XL machine, use the TERMINATE LOCKOUT function of the Control Test in the SERVICE menu. This will help to turn on pumps and advise the proper procedure. The following procedure describes how to equalize refrigerant pressure on an isolated 19XL machine without a pumpout unit:

1. Access TERMINATE LOCKOUT function on the Control Test.
2. Turn on the chilled water and condenser water pumps to ensure against freezing.
3. Slowly open the refrigerant cooling isolation valve. The machine cooler and condenser pressures will gradually equalize. This process will take approximately 15 minutes.
4. Once the pressures have equalized, the condenser isolation valve, the optional hot gas isolation valve, and cooler isolation valve may now be opened. Refer to [Figure 27](#) and [Figure 28](#), Valves 11, 12, and 14.

**WARNING**



**WARNING**

**Whenever turning the discharge isolation valve, be sure to re-attach the valve locking device. This will prevent the valve from opening or closing during service work or during machine operation.**

[Click here for Table 8 — Control Test Menu Functions](#)



## 19XL Machine Equalization with Pumpout Unit

The following procedure describes how to equalize refrigerant pressure on an isolated 19XL machine using the pumpout unit:

1. Access the TERMINATE LOCKOUT mode in the Control Test.
2. Turn on the chilled water and condenser water pumps to prevent possible freezing.
3. Open valve 4 on the pumpout unit and open valves 1a and 1b on the cooler and condenser, [Figure 27](#) and [Figure 28](#). Slowly open valve 2 on the pumpout unit to equalize the pressure. This process will take approximately 15 minutes.
4. Once the pressures have equalized, the discharge isolation valve, cooler isolation valve, optional hot gas bypass isolation valve, and the refrigerant isolation valve can be opened. Close valves 1a and 1b, and all pumpout unit valves.

**WARNING**



**WARNING**

**Whenever turning the discharge isolation valve, be sure to re-attach the valve locking device. This will prevent the valve from opening or closing during service work or during machine operation.**

The full refrigerant charge on the 19XL will vary with machine components and design conditions, indicated on the job data specifications. An approximate charge may be found by



adding the condenser charge to the cooler charge listed in [Table 9](#).

Always operate the condenser and chilled water pumps during charging operations to prevent freeze-ups. Use the Control Test Terminate Lockout to monitor conditions and start the pumps.

If the machine has been shipped with a holding charge, the refrigerant will be added through the refrigerant charging valve ([Figure 27](#) and [Figure 28](#), valve 7) or to the pumpout charging connection. First evacuate the nitrogen holding charge from the vessels. Charge the refrigerant as a gas until the system pressure exceeds 68 psig (469 kPa) for HCFC-22; 35 psig (141 kPa) for HFC-134a. After the machine is beyond this pressure the refrigerant should be charged as a liquid until all of the recommended refrigerant charge has been added.





## Trimming Refrigerant Charge

The 19XL is shipped with the correct charge for the design duty of the machine. Trimming the charge can be best accomplished when design load is available. To trim, check the temperature difference between leaving chilled water temperature and cooler refrigerant temperature at full load design conditions. If necessary, add or remove refrigerant to bring the temperature difference to design conditions or minimum differential.

[Click here for Table 9 — Refrigerant \(HCFC-22 or HFC-134a\) Charges](#)

## Initial Start-up

### Preparation

Before starting the machine, check that the:

1. Power is on to the main starter, oil pump relay, tower fan starter, oil heater relay, and the machine control center.
2. Cooling tower water is at proper level, and at or below design entering temperature.
3. Machine is charged with refrigerant and all refrigerant and oil valves are in their proper operating position.
4. Oil is at the proper level in the reservoir sight glasses.



5. Oil reservoir temperature is above 140 F (60 C) or refrigerant temperature plus 50° F (28° C).
6. Valves in the evaporator and condenser water circuits are open.

**Note:** If pumps are not automatic, make sure water is circulating properly.

7. Solid-state starter checks: The Power +15 and the Phase Correct LEDs must be lit before the starter will energize. If the Power +15 LED is not on, incoming voltage is not present or is incorrect. If the Phase Correct LED is not lit, rotate any 2 incoming phases to correct the phasing.

**WARNING**



**WARNING**

**Do not permit water or brine that is warmer than 110 F (43 C) to flow through the cooler or condenser. Refrigerant overpressure may discharge through the relief devices and result in the loss of refrigerant charge.**

8. Press RELEASE to automate the chiller start/stop value on the Status01 table to enable the chiller to start. The initial factory setting of this value is overridden to stop in order to prevent accidental start-up.



## Manual Operation of the Guide Vanes

Manual operation of the guide vanes is helpful to establish a steady motor current for calibration of the motor amps value.

In order to manually operate the guide vanes, it is necessary to override the *TARGET GUIDE VANE POSITION* value which is accessed on the Status01 table. Manual control is indicated by the word “SUPVSR!” flashing after the target value position. Manual control is also indicated on the default screen on the run status line.

1. Access the Status01 table and look at the target guide vane position ([Figure 16](#)). If the compressor is off, the value will read zero.
2. Move the highlight bar to the *TARGET GUIDE VANE POSITION* line and press the SELECT softkey.
3. Press ENTER to override the automatic target. The screen will now read a value of zero, and the word “SUPVSR!” will flash.
4. Press the SELECT softkey, and then press RELEASE softkey to release the vanes to AUTOMATIC mode. After a few seconds the “SUPVSR!” will disappear.

## Dry Run to Test Start-Up Sequence

1. Disengage the main motor disconnect on the starter front panel. This should only disconnect the motor power. Power to the controls, oil pump, and starter control circuit should still be energized.



2. Look at the default screen on the LID: the Status message in the upper left-hand corner will show a “Manually Stopped” message. Press CCN or Local to start. If not, go to the Schedule screen and override the schedule or change the occupied time. Press the LOCAL softkey to begin the start-up sequences.
3. Check that chilled water and condenser water pumps energize.
4. Check that the oil pump starts and pressurizes the lubrication system. After the oil pump has run about 11 seconds, the starter will be energized and go through its start-up sequence.
5. Check the main contactor for proper operation.
6. The PIC will eventually show an alarm for motor amps not sensed. Reset this alarm and continue with the initial start-up.

## Check Rotation

1. Engage the main motor disconnect on the front of the starter panel. The motor is now ready for rotation check.
2. After the default screen Status message states “Ready for Start” press the LOCAL softkey; start-up checks will be made by the control.
3. When the starter is energized and the motor begins to turn. Check for clockwise rotation (Figure 34).

**If Rotation Is Proper**, allow the compressor to come up to speed.



**If the Motor Rotation Is Not Clockwise** (as viewed through the sight glass), reverse any 2 of the 3 incoming power leads to the starter and recheck rotation.

**Note:** Solid-state starters have phase protection and will not allow a start if the phase is not correct. Instead, a Starter Fault message will occur if this happens.

**CAUTION**



**CAUTION**

**Do not check motor rotation during coastdown. Rotation may have reversed during equalization of vessel pressures.**

[Click here for Figure 34 — Correct Motor Rotation](#)

### **Notes on Solid-State Starters (Benshaw, Inc.)**

1. When the compressor is energized to start by the 1CR relay, confirm that the Relay On LED is lit on the starter SCR control board. The compressor motor should start to turn immediately when this light comes on. If not, adjust the start torque potentiometer in a clockwise direction.
2. Observe that all 6-gate LEDs are lit on the starter SCR control board.



3. The factory setting should bring the motor to full voltage in 15 to 30 seconds. If the setting is not correct, adjust the ramp potentiometer counterclockwise for a shorter time, clockwise for a longer time. (See [Figure 6](#) for starter component placement.)

## Check Oil Pressure and Compressor Stop

1. When the motor is up to full speed, note the differential oil pressure reading on the LID default screen. It should be between 18 and 30 psid (124 to 206 kPad).
2. Press the Stop button and listen for any unusual sounds from the compressor as it coasts to a stop.

## Calibrate Motor Current Demand Setting

1. Make sure that the compressor motor rated load amps in the Service1 table has been configured. Place an ammeter on the line that passes through the motor load current transfer on the motor side of the power factor correction capacitors (if provided).
2. Start the compressor and establish a steady motor current value between 70% and 100% RLA by manually overriding the guide vane target value on the LID and setting the chilled water set point to a low value. Do not exceed 105% of the nameplate RLA.
3. When a steady motor current value in the desired range is met, compare the compressor motor amps value on the Status01 table to the actual amps shown on the ammeter on the starter. Adjust the amps value on the LID to the actual value seen at the starter if there is a difference. Highlight the amps value then press SELECT. Press INCREASE or DECREASE to bring the value to that indicated on the ammeter. Press ENTER when equal.
4. Make sure that the target guide vane position is released into AUTOMATIC mode.



## **To Prevent Accidental Start-Up**

The PIC can be set up so that start-up of the unit is more difficult than just pressing the LOCAL or CCN softkeys during machine service or when necessary. By accessing the Status01 table, and highlighting the chiller Start/Stop line, the value can be overridden to stop by pressing SELECT and then the STOP and ENTER softkeys. "SUPVSR" will appear after the value. When attempting to restart, remember to release the override. The default machine message line will also state that the Start/Stop has been set to "Start" or "Stop" when the value is overridden.

## **Check Machine Operating Condition**

Check to be sure that machine temperatures, pressures, water flows, and oil and refrigerant levels indicate that the system is functioning properly.

## **Instruct the Customer Operator**

Check to be sure that the operator(s) understand all operating and maintenance procedures. Point out the various machine parts and explain their function as part of the complete system.

## **Cooler-Condenser**

Float chamber, relief devices, refrigerant charging valve, temperature sensor locations, pressure transducer locations, Schrader fittings, waterboxes and tubes, and vents and drains.



## **Optional Storage Tank and Pumpout System**

Transfer valves and pumpout system, refrigerant charging and pumpdown procedure, and relief devices.

## **Motor Compressor Assembly**

Guide vane actuator, transmission, motor cooling system, oil cooling system, temperature and pressure sensors, oil sight glasses, integral oil pump, isolatable oil filter, extra oil and motor temperature sensors, synthetic oil, and compressor serviceability.

## **Motor Compressor Lubrication System**

Oil pump, cooler filter, oil heater, oil charge and specification, operating and shutdown oil level, temperature and pressure, and oil charging connections.

## **Control System**

CCN and Local start, reset, menu, softkey functions, LID operation, occupancy schedule, set points, safety controls, and auxiliary and optional controls.

## **Auxiliary Equipment**

Starters and disconnects, separate electrical sources, pumps, and cooling tower.

## **Describe Machine Cycles**

Refrigerant, motor cooling, lubrication, and oil reclaim.





## **Review Maintenance**

Scheduled, routine, and extended shutdowns, importance of a log sheet, importance of water treatment and tube cleaning, and importance of maintaining a leak-free machine.

## **Safety Devices and Procedures**

Electrical disconnects, relief device inspection, and handling refrigerant.

## **Check Operator Knowledge**

Start, stop, and shutdown procedures, safety and operating controls, refrigerant and oil charging, and job safety.

## **Review the Start-Up, Operation, and Maintenance Manual**

# **Operating Instructions**

## **Operator Duties**

1. Become familiar with refrigeration machine and related equipment before operating the machine.
2. Prepare the system for start-up, start and stop the machine, and place the system in a shutdown condition.
3. Maintain a log of operating conditions and document any abnormal readings.
4. Inspect the equipment, make routine adjustments, and perform a Control Test. Maintain the proper oil and refrigerant levels.



5. Protect the system from damage during shutdown periods.
6. Maintain the set point, time schedules, and other PIC functions.

## Prepare the Machine for Start-Up

Follow the steps described in the [Initial Start-Up](#) section.

## To Start the Machine

1. Start the water pumps, if they are not automatic.
2. On the LID default screen, press the LOCAL or CCN softkey to start the system. If the machine is in the OCCUPIED mode, and the start timers have expired, the start sequence will start. Follow the procedure described in the [Start-Up/Shutdown/Recycle](#) section.

## Check the Running System

After the compressor starts, the operator should monitor the LID display and observe the parameters for normal operating conditions:

1. The oil reservoir temperature should be above 140 F (60 C) during shutdown, and above 100 F (38 C) during compressor operation.
2. The bearing oil temperature accessed on the Status01 table should be 120 to 165 F (49 to 74 C). If the bearing temperature reads more than 180 F (83 C) with the oil pump running, stop the machine and determine the cause of the high temperature. *Do not restart* the machine until corrected.



3. The oil level should be visible anywhere in one of the two sight glasses. Foaming of the oil is acceptable as long as the oil pressure and temperature are within limits.
4. The oil pressure should be between 18 and 30 psid (124 to 207 kPad) differential, as seen on the LID default screen. Typically the reading will be 18 to 25 psid (124 to 172 kPad) at initial start-up.
5. The moisture indicator sight glass on the refrigerant motor cooling line should indicate refrigerant flow and a dry condition.
6. The condenser pressure and temperature varies with the machine design conditions. Typically the pressure will range between 100 and 210 psig (690 to 1450 kPa) with a corresponding temperature range of 60 to 105 F (15 to 41 C). The condenser entering water temperature should be controlled below the specified design entering water temperature to save on compressor kilowatt requirements.
7. Cooler pressure and temperature also will vary with the design conditions. Typical pressure range will be between 60 and 80 psig (410 and 550 kPa), with temperature ranging between 34 and 45 F (1 and 8 C).
8. The compressor may operate at full capacity for a short time after the pulldown ramping has ended, even though the building load is small. The active electrical demand setting can be overridden to limit the compressor kW, or the pulldown rate can be decreased to avoid a high demand charge for the short period of high demand operation. Pulldown rate can be



based on load rate or temperature rate. It is accessed on the Equipment Configuration, Config table (Table 2, [Example 5](#)).

## To Stop the Machine

1. The occupancy schedule will start and stop the machine automatically once the time schedule is set up.
2. By pressing the STOP button for one second, the alarm light will blink once to confirm that the button has been pressed, then the compressor will follow the normal shutdown sequence as described in the [Controls](#) section. The machine will not restart until the CCN or LOCAL softkey is pressed. The machine is now in the OFF mode. If the machine fails to stop, in addition to action that the PIC will initiate, the operator should close the guide vanes by overriding the guide vane target to zero to reduce machine load; then by opening the main disconnect. Do not attempt to stop the machine by opening an isolating knife switch. High intensity arcing may occur. *Do not restart* the machine until the problem is diagnosed and corrected.

## After Limited Shutdown

No special preparations should be necessary. Follow the regular preliminary checks and starting procedures.



## Extended Shutdown

The refrigerant should be transferred into the storage vessel (if supplied; see [Pumpout and Refrigerant Transfer Procedures](#)) in order to reduce machine pressure and possibility of leaks. Maintain a holding charge of 5 to 10 lbs (2.27 to 4.5 kg) of refrigerant to prevent air from leaking into the machine.

If freezing temperatures are likely to occur in the machine area, drain the chilled water, condenser water, and the pumpout condenser water circuits to avoid freeze-up. Keep the waterbox drains open.

Leave the oil charge in the machine with the oil heater and controls energized to maintain the minimum oil reservoir temperature.

## After Extended Shutdown

Be sure that the water system drains are closed. It may be advisable to flush the water circuits to remove any soft rust which may have formed. This is a good time to brush the tubes if necessary.

Check the cooler pressure on the LID default screen, and compare to the original holding charge that was left in the machine. If (after adjusting for ambient temperature changes) any loss in pressure is indicated, check for refrigerant leaks. See [Check Machine Tightness](#) section.

Recharge the machine by transferring refrigerant from the storage tank (if supplied). Follow the [Pumpout and Refrigerant Transfer Procedures](#) section. Observe freeze-up precautions.



Carefully make all regular preliminary and running system checks. Perform a Control Test before start-up. If the compressor oil level appears abnormally high, the oil may have absorbed refrigerant. Make sure that the oil temperature is above 140 F (60 C) or cooler refrigerant temperature plus 50° F (27° C).

## Cold Weather Operation

When the entering condenser water drops very low, the operator should automatically cycle the cooling tower fans off to keep the temperature up. Piping may also be arranged to bypass the cooling tower. The PIC controls have a low limit tower fan relay (PR3) that can be used to assist in this control.

## Manual Guide Vane Operation

Manual operation of the guide vanes in order to check control operation or control of the guide vanes in an emergency operation is possible by overriding the target guide vane position. Access the Status01 table on the LID and highlight *TARGET GUIDE VANE POSITION*. To control the position, enter a percentage of guide vane opening that is desired. Zero percent is fully closed, 100% is fully open. To release the guide vanes to AUTOMATIC mode, press the RELEASE softkey.

**Note:** Manual control will increase the guide vanes and override the pulldown rate during start-up. Motor current above the electrical demand setting, capacity overrides, and chilled water below control point will override the manual target and close the guide vanes. For descriptions of capacity overrides and set points, see the **Controls** section.



## Refrigeration Log

A refrigeration log, such as the one shown in [Figure 35](#), provides a convenient checklist for routine inspection and maintenance and provides a continuous record of machine performance. It is an aid in scheduling routine maintenance and in diagnosing machine problems.

Keep a record of the machine pressures, temperatures, and liquid levels on a sheet similar to that shown. Automatic recording of PIC data is possible through the use of CCN devices such as the Data Collection module and a Building Supervisor. Contact your Carrier representative for more information.

[Click here for Figure 35 — Refrigeration Log \(For Print\)](#)



# Pumpout and Refrigerant Transfer Procedures

## Preparation

The 19XL may come equipped with an optional storage tank or pumpout system, or a pumpout compressor. The refrigerant can be pumped for service work to either the cooler/compressor vessel, or the condenser vessel by using the optional pumpout system. If a storage tank is supplied, the refrigerant can be isolated in the external tank. The following procedures are used to describe how to transfer refrigerant from vessel to vessel and perform machine evacuations.

## Operating the Optional Pumpout Compressor

1. Be sure that the suction and the discharge service valves on the optional pumpout compressor are open (backseated) during operation. Rotate the valve stem fully counterclockwise to open. Frontseating the valve closes the refrigerant line and opens the gage port to compressor pressure.
2. Make sure that the compressor holddown bolts have been loosened to allow free spring travel.
3. Open the refrigerant inlet valve on the pumpout compressor.
4. Oil should be visible in the compressor sight glass under all operating conditions and during shutdown. If oil is low, add oil as described under [Optional Pumpout System Maintenance](#) section. The pumpout unit control wiring schematic is detailed in [Figure 36](#).





**To Read Refrigerant Pressures** during pumpout or leak testing:

1. The LID display on the machine control center is suitable for determining refrigerant-side pressures and low (soft) vacuum. For evacuation or dehydration measurement, use a quality vacuum indicator or manometer to ensure the desired range and accuracy. This can be placed on the Schrader connections on each vessel ([Figure 8](#)) by removing the pressure transducer.
2. To determine storage tank pressure, a 30 in.-0-400 psi (-101- 0-2760 kPa) gage is attached to the vessel.
3. Refer to [Figure 27](#), [Figure 28](#), and [Figure 37](#) for valve locations and numbers.

**CAUTION**



**CAUTION**

**Transfer, addition, or removal of refrigerant in spring-isolated machines may place severe stress on external piping if springs have not been blocked in both up and down directions.**

## Machines with Storage Tanks

If the machine has isolation valves, leave them open for the following procedures. The letter “C” describes a closed valve. Valves 9 and 10 on the storage tank are always closed. See [Figure 16](#), [Figure 17](#), [Figure 27](#), and [Figure 28](#).



## Transfer Refrigerant from Storage Tank to Machine

1. Equalize refrigerant pressure.
  - a. Use the Control Test Terminate Lockout to turn on water pumps and monitor pressures.
  - b. Close pumpout/storage tank valves 2, 4, 5, and 8, and close machine charging valve 7; open machine isolation valves 11, 12, 13, and 14 (if present).
  - c. Open pumpout/storage tank valves 3 and 6, open machine valves 1a and 1b.

Valve	1a	1b	2	3	4	5	6	7	8	11	12	13	14
Condition			C		C	C		C	C				

[Click here for Figure 36 — 19XL Pumpout Unit Wiring Schematic](#)

[Click here for Figure 37 — Optional Pumpout System](#)

- d. Gradually crack open valve 5 to increase machine pressure to 68 psig (469 kPa) for HCFC-22, 35 psig (141 kPa) for HFC-134a. Slowly feed refrigerant to prevent freeze up.



- e. Open valve 5 fully after the pressure rises above the freeze point of the refrigerant. Open liquid line valve 7 until refrigerant pressure equalizes.

Valve	1a	1b	2	3	4	5	6	7	8	11	12	13	14
Condition			C		C				C				

2. Transfer remaining refrigerant.

- a. Close valve 5 and open valve 4.

Valve	1a	1b	2	3	4	5	6	7	8	11	12	13	14
Condition			C			C			C				

- b. Turn off the water pumps through the LID.  
 c. Turn off the pumpout condenser water, and turn on the pumpout compressor to push liquid out of the storage tank.  
 d. Close liquid line valve 7.  
 e. Turn off the pumpout compressor.  
 f. Close valves 3 and 4.



g. Open valves 2 and 5.

Valve	1a	1b	2	3	4	5	6	7	8	11	12	13	14
Condition				C	C			C	C				

h. Turn on pumpout condenser water.

i. Run the pumpout compressor until the storage tank pressure reaches 5 psig (34 kPa) (18 in. Hg [40 kPa absolute] if repairing the tank).

j. Turn off the pumpout compressor.

k. Close valves 1a, 1b, 2, 5, and 6.

l. Turn off pumpout condenser water.

Valve	1a	1b	2	3	4	5	6	7	8	11	12	13	14
Condition	C	C	C	C	C	C	C	C	C				



## Transfer the Refrigerant from Machine to Storage Tank

1. Equalize refrigerant pressure.

a. Valve positions:

Valve	1a	1b	2	3	4	5	6	7	8	11	12	13	14
Condition			C		C	C		C	C				

b. Slowly open valve 5 and liquid line valve 7 to allow liquid refrigerant to drain by gravity into the storage tank.

Valve	1a	1b	2	3	4	5	6	7	8	11	12	13	14
Condition			C		C				C				

2. Transfer the remaining liquid.

a. Turn off pumpout condenser water. Place valves in the following positions:

Valve	1a	1b	2	3	4	5	6	7	8	11	12	13	14
Condition				C	C				C				



- b. Run the pumpout compressor for 30 minutes then close valve 7.
- c. Turn off the pumpout compressor.

Valve	1a	1b	2	3	4	5	6	7	8	11	12	13	14
Condition				C	C			C	C				

3. Remove any remaining refrigerant.

- a. Turn on water pumps through the use of the Control Test Pumpdown.
- b. Turn on pumpout condenser water.
- c. Place valves in the following positions:

Valve	1a	1b	2	3	4	5	6	7	8	11	12	13	14
Condition			C			C		C	C				

- d. Run the pumpout compressor until the machine pressure reaches 65 psig (448 kPa) for HCFC-22, 30 psig (207 kPa) for HFC-134a, then shut off the pumpout. Warm condenser water will boil off any entrapped liquid refrigerant and machine pressure will rise.
- e. When the pressure rises to 70 psig (483 kPa) for HCFC-22, 40 psig (276 kPa) for HFC-134a, turn on the pumpout compressor until the pressure again reaches 65 psig



(448 kPa) for HCFC-22, 30 psig (207 kPa) for HFC-134a, and then turn off the compressor. Repeat this process until the pressure no longer rises, then turn on the pumpout compressor and pumpout until the pressure reaches 18 in. Hg. (40 kPa absolute).

f. Close valves 1a, 1b, 3, 4, and 6.

Valve	1a	1b	2	3	4	5	6	7	8	11	12	13	14
Condition	C	C	C	C	C	C	C	C	C				

g. Turn off the pumpout condenser water and continue with the Control Test for Pumpdown, which will lock out the machine compressor for operation.

4. Establish vacuum for service.

a. In order to conserve refrigerant, operate the pumpout compressor until the machine pressure is reduced to 18 in. Hg vac., ref 30 in. bar. (40 kPa abs.) following Step 3e.



# Machines with Isolation Valves

## Transfer All Refrigerant to Condenser Vessel

1. Push refrigerant into condenser.
  - a. Valve positions:

Valve	1a	1b	2	3	4	5	8	11	12	13	14
Condition				C	C		C		C	C	C

- b. Turn off machine water pumps and pumpout condenser water.
- c. Turn on pumpout compressor to push liquid out of the cooler/compressor.
- d. When all liquid has been pushed into the condenser, close cooler isolation valve 11.
- e. Access the Control Test, Pumpdown table on the LID display to turn on the machine water pumps.
- f. Turn off the pumpout compressor.





2. Evacuate gas from cooler/compressor vessel.

- a. Close pumpout valves 2 and 5, and open valves 3 and 4.

Valve	1a	1b	2	3	4	5	8	11	12	13	14
Condition			C			C	C	C	C	C	C

- b. Turn on pumpout condenser water.

- c. Run pumpout until the compressor reaches 18 in. Hg vac (40 kPa abs.). Monitor pressures on the LID and on refrigerant gages.

- d. Close valve 1a.

- e. Turn off pumpout compressor.

- f. Close valves 1b, 3, and 4.

- g. Turn off pumpout condenser water.

Valve	1a	1b	2	3	4	5	8	11	12	13	14
Condition	C	C	C	C	C	C	C	C	C	C	C

- h. Proceed to Pumpdown test on the LID to turn off machine water pumps and lock out machine compressor.



## Transfer All Refrigerant to Cooler/Compressor Vessel

1. Push refrigerant into the cooler vessel.

a. Valve positions:

Valve	1a	1b	2	3	4	5	8	11	12	13	14
Condition			C			C	C		C	C	C

b. Turn off machine water pumps and pumpout condenser water.

c. Turn on pumpout compressor to push refrigerant out of the condenser.

d. When all liquid is out of the condenser, close cooler isolation valve 11.

e. Turn off the pumpout compressor.

2. Evacuate gas from the condenser vessel.

a. Access the Control Test, Pumpdown table on the LID display to turn on the machine water pumps.

b. Close pumpout valves 3 and 4; open valves 2 and 5.

Valve	1a	1b	2	3	4	5	8	11	12	13	14
Condition				C	C		C	C	C	C	C



- c. Turn on pumpout condenser water.
- d. Run the pumpout until the compressor reaches 18 in. Hg vac (40 kPa abs.). Monitor pressure at the LID and refrigerant gages.
- e. Close valve 1b.
- f. Turn off pumpout compressor.
- g. Close valves 1a, 2, and 5.

Valve	1a	1b	2	3	4	5	8	11	12	13	14
Condition	C	C	C	C	C	C	C	C	C	C	C

- h. Turn off pumpout condenser water.
- i. Proceed to Pumpdown test on the LID to turn off machine water pumps and lockout machine compressor.



## Return Refrigerant to Normal Operating Conditions

1. Be sure that the vessel that was opened has been evacuated.
2. Access the Control Test Terminate Lockout table to view vessel pressures and turn on machine water pumps.
3. Open valves 1a, 1b, and 3.

Valve	1a	1b	2	3	4	5	8	11	12	13	14
Condition			C		C	C	C	C	C	C	C

4. Crack open valve 5, gradually increasing pressure in the evacuated vessel to 68 psig (469 kPa), for HCFC-22, 35 psig (141 kPa) for HFC-134a. Feed refrigerant slowly to prevent tube freeze up.
5. Leak test to ensure vessel integrity.
6. Open valve 5 fully.

Valve	1a	1b	2	3	4	5	8	11	12	13	14
Condition			C		C		C	C	C	C	C

7. Open valve 11 to equalize the liquid refrigerant level between vessels.



8. Close valves 1a, 1b, 3, and 5.
9. Open isolation valves 12, 13, and 14 (if present).

Valve	1a	1b	2	3	4	5	8	11	12	13	14
Condition	C	C	C	C	C	C	C				

10. Proceed to Terminate Pumpdown Lockout test to turn off water pumps and enable the machine compressor for start-up.



## General Maintenance

### Refrigerant Properties

HCFC-22 or HFC-134a is the standard refrigerant in the 19XL. At normal atmospheric pressure, HCFC-22 will boil at  $-41\text{ F}$  ( $-40\text{ C}$ ) and HFC-134a will boil at  $-14\text{ F}$  ( $-25\text{ C}$ ) and must, therefore, be kept in pressurized containers or storage tanks. The refrigerants are practically odorless when mixed with air. Both refrigerants are non-combustible at atmospheric pressure. Read the Material Safety Data Sheet and the latest ASHRAE Safety Guide for Mechanical Refrigeration to learn more about safe handling of these refrigerants.

**DANGER**



**DANGER**

**HCFC-22 and HFC-134a will dissolve oil and some nonmetallic materials, dry the skin, and, in heavy concentrations, may displace enough oxygen to cause asphyxiation. In handling this refrigerant, protect the hands and eyes and avoid breathing fumes.**



## Adding Refrigerant

Follow the procedures described in [Trimming Refrigerant Charge](#) section.

**WARNING**



**WARNING**

**Always use the compressor Pumpdown function in the Control Test table to turn on the evaporator pump and lock out the compressor when transferring refrigerant. Liquid refrigerant may flash into a gas and cause possible freeze-up when the machine pressure is below 65 psig (448 kPa), for HCFC-22, 30 psig (207 kPa) for HFC-134a.**

## Removing Refrigerant

If the optional pumpout system is used, the 19XL refrigerant charge may be transferred to a storage vessel, or within the condenser or cooler. Follow procedures in the [Pumpout and Refrigerant Transfer Procedures](#) section when removing refrigerant from the storage tank to the machine.

## Adjusting the Refrigerant Charge

If the addition or removal of refrigerant is required for improved machine performance, follow the procedures given under the [Trim Refrigerant Charge](#) section.



Contents

## Refrigerant Leak Testing

Because HCFC-22 and HFC-134a are above atmospheric pressure at room temperature, leak testing can be performed with refrigerant in the machine. Use an electronic, halide leak detector, soap bubble solution, or ultra-sonic leak detector. Be sure that the room is well ventilated and free from concentration of refrigerant to keep false readings to a minimum. Before making any necessary repairs to a leak, transfer all refrigerant from the leaking vessel.

## Leak Rate

ASHRAE recommends that machines should be immediately taken off line and repaired if the refrigerant leakage rate for the entire machine is more than 10% of the operating refrigerant charge per year. Additionally, Carrier recommends that leaks totalling less than the above rate but more than a rate of 1 lb (0.5 kg) per year should be repaired during annual maintenance or whenever the refrigerant is pumped over for other service work.

## Test After Service, Repair, or Major Leak

If all refrigerant has been lost or if the machine has been opened for service, the machine or the affected vessels must be pressured and leak tested. Refer to the [Leak Test Machine](#) section to perform a leak test.





**WARNING**



**WARNING**

**HCFC-22 and HFC-134a should not be mixed with air or oxygen and pressurized for leak testing. In general, neither refrigerant should not be allowed to be present with high concentrations of air or oxygen above atmospheric pressures, as the mixture can undergo combustion.**

## Refrigerant Tracer

Use an environmentally acceptable refrigerant as a tracer for leak test procedures.

## To Pressurize with Dry Nitrogen

Another method of leak testing is to pressurize with nitrogen only and use a soap bubble solution or an ultrasonic leak detector to determine if leaks are present. This should only be done if all refrigerant has been evacuated from the vessel.

1. Connect a copper tube from the pressure regulator on the cylinder to the refrigerant charging valve. Never apply full cylinder pressure to the pressurizing line. Follow the listed sequence.
2. Open the charging valve fully.
3. Slowly open the cylinder regulating valve.
4. Observe the pressure gage on the machine and close the regulating valve when the pressure reaches test level. *Do not exceed 140 psig (965 kPa).*



5. Close the charging valve on the machine. Remove the copper tube if no longer required.

## Repair the Leak, Retest, and Apply Standing Vacuum Test

After pressurizing the machine, test for leaks with an electronic, halide leak detector, soap bubble solution, or an ultrasonic leak detector. Bring the machine back to atmospheric pressure, repair any leaks found, and retest.

After retesting and finding no leaks, apply a standing vacuum test, and then dehydrate the machine. Refer to the [Standing Vacuum Test](#) and [Machine Dehydration](#) in the Before Initial Start-Up section.

## Checking Guide Vane Linkage

When the machine is off, the guide vanes are closed and the actuator mechanism is in the position shown in [Figure 38](#). If slack develops in the drive chain, backlash can be eliminated as follows:

1. With the machine shut down and the actuator fully closed, remove the chain guard and loosen the actuator bracket holddown bolts.
2. Loosen guide vane sprocket adjusting bolts.
3. Pry bracket upwards to remove slack, then retighten the bracket holddown bolts.
4. Retighten the guide vane sprocket adjusting bolts. Make sure that the guide vane shaft is rotated fully in the clockwise direction in order for it to be fully closed.



## Checking the Auxiliary Switch on Guide Vane Actuator

The auxiliary switch used to activate the oil reclaim system solenoids should move to the OPEN position when the actuator is 70 degrees open. (At this point the guide vanes should be 30 degrees open.)

[Click here for Figure 38 — Guide Vane Actuator Linkage](#)

## Trim Refrigerant Charge

If it becomes necessary to adjust the refrigerant charge to obtain optional machine performance, operate the machine at design load and then add or remove refrigerant slowly until the difference between leaving chilled water temperature and the cooler refrigerant temperature reaches design conditions or becomes a minimum. *Do not overcharge.*

Refrigerant may be added either through the storage tank or directly into the machine as described in the section entitled, [Refrigerant Charging](#).

To remove any excess refrigerant, follow the procedure in [Transfer Refrigerant from Machine to Storage Tank](#) section, Steps 1a and b.



# Weekly Maintenance

## Check the Lubrication System

Mark the oil level on the reservoir sight glass, and observe the level each week while the machine is shut down.

If the level goes below the lower sight glass, the oil reclaim system will need to be checked for proper operation. If additional oil is required, add it through the oil drain charging valve ([Figure 2A](#) or [Figure 2B](#)). A pump is required for adding oil against refrigerant pressure. The oil charge is approximately 8 gallons (30 L). The added oil *must* meet Carrier specifications for the 19XL. Refer to [Changing Oil Filter](#) and [Oil Changes](#) sections. Any additional oil that is added should be logged by noting the amount and date. Any oil that is added due to oil loss that is not related to service will eventually return to the sump. It must be removed when the level is high.

A 1200-watt oil heater is controlled by the PIC to maintain oil temperature (see the [Controls](#) section) when the compressor is off. The LID Status02 table displays whether the heater is energized or not. If the PIC shows that the heater is energized, but the sump is not heating up, the power to the oil heater may be off or the oil level may be too low. Check the oil level, the oil heater contactor voltage, and oil heater resistance.

The PIC will not permit compressor start-up if the oil temperature is too low. The control will continue with start-up only after the temperature is within limits.



## Scheduled Maintenance

Establish a regular maintenance schedule based on the actual machine requirements such as machine load, run hours, and water quality. The time intervals listed in this section are offered as guides to service only.

### Service Ontime

The LID will display a *SERVICE ONTIME* value on the Status01 table. This value should be reset to zero by the service person or the operator each time major service work is completed so that time between service can be viewed.

### Inspect the Control Center

Maintenance is limited to general cleaning and tightening of connections. Vacuum the cabinet to eliminate dust build-up. In the event of machine control malfunctions, refer to the [Troubleshooting Guide](#) section for control checks and adjustments.

**CAUTION**



**CAUTION**

**Be sure power to the control center is off when cleaning and tightening connections inside the control center.**



## Check Safety and Operating Controls Monthly

To ensure machine protection, the Control Test Automated Test should be done at least once per month. See [Table 3](#) for safety control settings. See [Table 8](#) for Control Test functions.

## Changing Oil Filter

Change the oil filter on a yearly basis or when the machine is opened for repairs. The 19XL has an isolatable oil filter so that the filter may be changed with the refrigerant remaining in the machine. Use the following procedure:

1. Make sure that the compressor is off, and the disconnect for the compressor is open.
2. Disconnect the power to the oil pump.
3. Close the oil filter isolation valves ([Figure 4](#)).
4. Connect an oil charging hose from the oil charging valve ([Figure 4](#)), and place the other end in a clean container suitable for used oil. The oil drained from the filter housing should be used as an oil sample to be sent to a laboratory for proper analysis. *Do not contaminate this sample.*
5. Slowly open the charging valve to drain the oil from the housing.



**CAUTION**



**CAUTION**

**The oil filter housing is at a high pressure. Relieve this pressure slowly.**

6. Once all oil has been drained, place some rags or absorbent material under the oil filter housing to catch any drips once the filter is opened. Remove the 4 bolts from the end of the filter housing and remove the filter cover.
7. Remove the filter retainer by unscrewing the retainer nut. The filter may now be removed and disposed of properly.
8. Replace the old filter with a new filter. Install the filter retainer and tighten down the retainer nut. Install the filter cover and tighten the 4 bolts.
9. Evacuate the filter housing by placing a vacuum pump on the charging valve. Follow the normal evacuation procedures. Shut the charging valve when done, and reconnect the valve so that new oil can be pumped into the filter housing. Fill with the same amount that was removed, then close the charging valve.
10. Remove the hose from the charging valve, open the isolation valves to the filter housing, and turn on the power to the pump and the motor.

## Oil Specification

If oil is to be added, it must meet the following Carrier specifications:

- Oil type for HCFC-22 Machines only... Alkyl-benzene-based synthetic compressor oil specifically formatted for use in HCFC-22 gear-driven machines  
ISO Viscosity Grade .....86
- Oil Type for units using R-134a.....Inhibited polyolester-based synthetic compressor oil formatted for use with HFC, gear-driven, hermetic compressors.  
ISO Viscosity Grade .....68

The alkyl-benzene type oil (part number PP23BZ101) or the polyolester-based oil (P/N: PP23BZ103) may be ordered from your local Carrier representative.

## Oil Changes

Carrier recommends changing the oil after the first year of operation and every three years thereafter as a minimum in addition to a yearly oil analysis. However, if a continuous oil monitoring system is functioning and a yearly oil analysis is performed, time between oil changes can be extended.

## To Change the Oil

1. Transfer the refrigerant into the condenser (for isolatable vessels) or a storage tank.
2. Mark the existing oil level.
3. Open the control and oil heater circuit breaker.





4. When the machine pressure is 5 psi (34 kPa) or less, drain the oil reservoir by opening the oil charging valve ([Figure 2A](#) or [Figure 2B](#)). Slowly open the valve against refrigerant pressure.
5. Change the oil filter at this time. See [Changing Oil Filter](#) section.
6. Change the refrigerant filter at this time, see the next section, [Refrigerant Filter](#).
7. Charge the machine with oil. Charge until the oil level is equal to the oil level marked in Step 2. Turn on the power to the oil heater and let the PIC warm it up to at least 140 F (60 C). Operate the oil pump manually, through the Control Test, for 2 minutes. The oil level should be full in the lower sight glass for shutdown conditions. If the oil level is above 1/2 full in the upper sight glass, remove the excess oil. The oil level should now be equal to the amount shown in Step 2.

## Refrigerant Filter

A refrigerant filter/drier, located on the refrigerant cooling line to the motor ([Figure 2A](#) or [Figure 2B](#)), should be changed once a year, or more often if filter condition indicates a need for more frequent replacement. Change the filter with the machine pressure at 0 psig (0 kPa) by transferring the refrigerant to the condenser vessel, (if isolation valves are present), or a storage tank. A moisture indicator sight glass is located beyond this filter to indicate the volume and moisture in the refrigerant. If the moisture indicator (dry-eye) indicates moisture, locate the source of water immediately by performing a thorough leak check.



## Oil Reclaim Filters

The oil reclaim system has a strainer on the eductor suction line and a filter on the cooler scavaging line. Replace these filters once per year, or more often if filter condition indicates a need for more frequent replacement. Change these filters by transferring the refrigerant charge to a storage vessel or the condenser.

## Inspect Refrigerant Float System

Perform inspection every 5 years or when the condenser is opened for service. Transfer the refrigerant into the cooler vessel or into a storage tank. Remove the float access cover. Clean the chamber and valve assembly thoroughly. Be sure that the valve moves freely. Make sure that all openings are free of obstructions. Examine the cover gasket and replace if necessary. See [Figure 39](#) for views of both float valve designs. On the linear float valve design, inspect orientation of the float slide pin. It must be pointed toward the bubbler tube for proper operation.

[Click here for Figure 39 — 19XL Float Valve Designs](#)

## Inspect Relief Valves and Piping

The relief valves on this machine protect the system against the potentially dangerous effects of overpressure. To ensure against damage to the equipment and possible injury to personnel, these devices must be kept in peak operating condition.



As a minimum, the following maintenance is required.

1. At least once a year, disconnect the vent piping at the valve outlet and carefully inspect the valve body and mechanism for any evidence of internal corrosion or rust, dirt, scale, leakage, etc.
2. If corrosion or foreign material is found, do not attempt to repair or recondition. *Replace the valve.*
3. If the machine is installed in a corrosive atmosphere or the relief valves are vented into a corrosive atmosphere, make valve inspections at more frequent intervals.

## **Compressor Bearing and Gear Maintenance**

The key to good bearing and gear maintenance is proper lubrication. Use the proper grade of oil, maintained at recommended level, temperature, and pressure. Inspect the lubrication system regularly and thoroughly.

To inspect the bearings, a complete compressor teardown is required. Only a trained service technician should remove and examine the bearings. The cover plate on older compressor bases was used for factory-test purposes, and is not usable for bearing or gear inspection. The bearings and gears should be examined on a scheduled basis for signs of wear. The frequency of examination is determined by the hours of machine operation, load conditions during operation, and the condition of the oil and the lubrication system. Excessive bearing wear can sometimes be detected through increased vibration or increased bearing temperature. If either



symptom appears, contact an experienced and responsible service organization for assistance.

## **Inspect the Heat Exchanger Tubes**

### **Cooler**

Inspect and clean the cooler tubes at the end of the first operating season. Because these tubes have internal ridges, a rotary-type tube cleaning system is necessary to fully clean the tubes. Upon inspection, the tube condition will determine the scheduled frequency for cleaning, and will indicate whether water treatment is adequate in the chilled water/brine circuit. Inspect the entering and leaving chilled water temperature sensors for signs of corrosion or scale. Replace the sensor if corroded or remove any scale if found.

### **Condenser**

Since this water circuit is usually an open-type system, the tubes may be subject to contamination and scale. Clean the condenser tubes with a rotary tube cleaning system at least once per year, and more often if the water is contaminated. Inspect the entering and leaving condenser water sensors for signs of corrosion or scale. Replace the sensor if corroded or remove any scale if found.

Higher than normal condenser pressures, together with the inability to reach full refrigeration load, usually indicate dirty tubes or air in the machine. If the refrigeration log indicates a rise above normal condenser pressures, check the condenser refrigerant temperature against the



leaving condenser water temperature. If this reading is more than what the design difference is supposed to be, then the condenser tubes may be dirty, or water flow may be incorrect. Because HCFC-22 and HFC134-a are high-pressure refrigerants, air usually does not enter the machine, rather, the refrigerant leaks out.

During the tube cleaning process, use brushes especially designed to avoid scraping and scratching the tube wall. Contact your Carrier representative to obtain these brushes. *Do not* use wire brushes.

**CAUTION**



**CAUTION**

**Hard scale may require chemical treatment for its prevention or removal. Consult a water treatment specialist for proper treatment.**

## Water Leaks

Water is indicated during machine operation by the refrigerant moisture indicator ([Figure 2A](#) or [Figure 2B](#)) on the refrigerant motor cooling line. Water leaks should be repaired immediately.



**CAUTION**



**CAUTION**

**Machine must be dehydrated after repair of water leaks. See [Machine Dehydration](#) section.**

## **Water Treatment**

Untreated or improperly treated water may result in corrosion, scaling, erosion, or algae. The services of a qualified water treatment specialist should be obtained to develop and monitor a treatment program.

**CAUTION**



**CAUTION**

**Water must be within design flow limits, clean, and treated to ensure proper machine performance and reduce the potential of tubing damage due to corrosion, scaling, erosion, and algae. Carrier assumes no responsibility for chiller damage resulting from untreated or improperly treated water.**



## Inspect the Starting Equipment

Before working on any starter, shut off the machine, and open all disconnects supplying power to the starter.

**WARNING**



**WARNING**

**The disconnect on the starter front panel does not deenergize all internal circuits. Open all internal and remote disconnects before servicing the starter.**

**WARNING**



**WARNING**

**Never open isolating knife switches while equipment is operating. Electrical arcing can cause serious injury.**

Inspect starter contact surfaces for wear or pitting on mechanical-type starters. Do not sandpaper or file silver-plated contacts. Follow the starter manufacturer's instructions for contact replacement, lubrication, spare parts ordering, and other maintenance requirements.

Periodically vacuum or blow off accumulated debris on the internal parts with a high-velocity, low-pressure blower.

Power connections on newly installed starters may relax and loosen after a month of operation. Turn power off and retighten. Recheck annually thereafter.



**CAUTION**



**CAUTION**

**Loose power connections can cause voltage spikes, overheating, malfunctioning, or failures.**

## **Check Pressure Transducers**

Once a year, the pressure transducers should be checked against a pressure gage reading. Check all three transducers: oil pressure, condenser pressure, cooler pressure.

Note the evaporator and condenser pressure readings on the Status01 table on the LID. Attach an accurate set of refrigeration gages to the cooler and condenser Schrader fittings. Compare the two readings. If there is a difference in readings, the transducer can be calibrated, as described in the [Troubleshooting Guide](#) section.

## **Optional Pumpout System Maintenance**

For compressor maintenance details, refer to the 06D, 07D Installation, Start-Up, and Service Instructions.





## Optional Pumpout Compressor Oil Charge

Use oil conforming to Carrier specifications for reciprocating compressor usage. Oil requirements are as follows:

ISO Viscosity ..... 68

Carrier Part Number ..... PP23BZ103

The total oil charge, 4.5 pints (2.6 L), consists of 3.5 pints (2.0 L) for the compressor and one additional pint (0.6 L) for the oil separator.

Oil should be visible in one of the compressor sight glasses both during operation and at shutdown. Always check the oil level before operating the compressor. Before adding or changing oil, relieve the refrigerant pressure as follows:

1. Attach a pressure gage to the gage port of either compressor service valve (Figure 37).
2. Close the suction service valve and open the discharge line to the storage tank or the machine.
3. Operate the compressor until the crankcase pressure drops to 2 psig (13 kPa).
4. Stop the compressor and isolate the system by closing the discharge service valve.
5. Slowly remove the oil return line connection (Figure 37). Add oil as required.
6. Replace the connection and reopen the compressor service valves.



## Optional Pumpout Safety Control Settings (Figure 40)

The optional pumpout system high-pressure switch should open at  $220 \pm 5$  psig ( $1517 \pm 34$  kPa) and should reset automatically on pressure drop to 190 psig (1310 kPa) for HCFC-22 machines. For machines using HFC-134a, the switch opens at 161 psig (1110 kPa) and closes at 130 psig (896 kPa). Check the switch setting by operating the pumpout compressor and slowly throttling the pumpout condenser water.

[Click here for Figure 40 — Optional Pumpout System Controls](#)

## Ordering Replacement Chiller Parts

When ordering Carrier specified parts, the following information must accompany an order:

- machine model number and serial number
- name, quantity, and part number of the part required
- delivery address and method of shipment.



# Troubleshooting Guide

## Overview

The PIC has many features to aid the operator and the technician in troubleshooting a 19XL machine.

- By using the LID display, the chiller actual operating conditions can be viewed while the unit is running.
- When an alarm occurs, the default LID screen will freeze at the time of alarm. The freeze enables the operator to view the machine conditions at the time of alarm. The Status tables will still show the current information. Once all alarms have been cleared, the default LID screens will return to normal operation.
- The Control Algorithm Status tables will display various screens of information in order to diagnose problems with chilled water temperature control, chilled water temperature control overrides, hot gas bypass, surge algorithm status, and time schedule operation.
- The Control Test feature allows proper operation and testing of temperature sensors, pressure transducers, the guide vane actuator, oil pump, water pumps, tower control, and other on/off outputs while the compressor is stopped. It also has the ability to lock off the compressor and turn on water pumps for pumpout operation. The display will show the required temperatures and pressures during these operations.
- Other Service menu tables can access configured items, such as chilled water resets, override set points, etc.
- If an operating fault is detected, an alarm message is generated and displayed on the LID default screen. A more detailed message — along with a diagnostic message — also is stored into the Alarm History table.



## Checking the Display Messages

The first area to check when troubleshooting the 19XL is the LID display. If the alarm light is flashing, check the primary and secondary message lines on the LID default screen ([Figure 13](#)). These messages will indicate where the fault is occurring. The Alarm History table on the LID Service menu will also carry an alarm message to further expand on this alarm. For a complete listing of messages, see [Table 10](#). If the alarm light starts to flash while accessing a menu screen, depress EXIT to return to the Default screen to read the failure message. The compressor will not run with an alarm condition existing, unless the alarm type is an unauthorized start or a failure to shut down.

## Checking Temperature Sensors

All temperature sensors are of the thermistor type. This means that the resistance of the sensor varies with temperature. All sensors have the same resistance characteristics. Determine sensor temperature by measuring voltage drop if the controls are powered, or resistance if the controls are powered off. Compare the readings to the values listed in [Table 11A](#) or [Table 11B](#).

### Resistance Check

Turn off the control power and disconnect the terminal plug of the sensor in question from the module. Measure sensor resistance between receptacles designated by the wiring diagram with



a digital ohmmeter. The resistance and corresponding temperature is listed in [Table 11A](#) or [Table 11B](#). Check the resistance of both wires to ground. This resistance should be infinite.

## Voltage Drop

Using a digital voltmeter, the voltage drop across any energized sensor can be measured while the control is energized. [Table 11A](#) or [Table 11B](#) lists the relationship between temperature and sensor voltage drop (volts dc measured across the energized sensor). Exercise care when measuring voltage to prevent damage to the sensor leads, connector plugs, and modules. Sensors should also be checked at the sensor plugs. Check the sensor wire at the sensor for 5 vdc if the control is powered.

**CAUTION**



**CAUTION**

**Relieve all refrigerant pressure or drain the water prior to replacing the temperature sensors.**

## Check Sensor Accuracy

Place the sensor in a medium of a known temperature and compare that temperature to the measured reading. The thermometer used to determine the temperature of the medium should be of laboratory quality with 0.5° F (.25° C) graduations. The sensor in question should be accurate to within 2° F (1.2° C).



See **Figure 8** for sensor locations. The sensors are immersed directly in the refrigerant or water circuits. The wiring at each sensor is easily disconnected by unlatching the connector. These connectors allow only one-way connection to the sensor. When installing a new sensor, apply a pipe sealant or thread sealant to the sensor threads.

## **Dual Temperature Sensors**

There are 2 sensors each on the bearing and motor temperature sensors for servicing convenience. In case one of the dual sensors is damaged, the other one can be used by moving a wire.

The number 2 terminal in the sensor terminal box is the common line. To use the second sensor, move the wire from the number 1 position to the number 3 position.

## **Checking Pressure Transducers**

There are 3 pressure transducers on the 19XL. These determine cooler, condenser, and oil pressure. The cooler and condenser transducers also are used by the PIC to determine the refrigerant temperatures. All 3 can be calibrated if necessary. It is not usually necessary to calibrate at initial start-up. However, at high altitude locations, calibration of the transducer will be necessary to ensure the proper refrigerant temperature/pressure relationship. Each transducer is supplied with 5 vdc power from a power supply. If the power supply fails, a transducer voltage reference alarm will occur. If the transducer reading is suspected of being



faulty, check the supply voltage. It should be 5 vdc  $\pm$  .5 v. If the supply voltage is correct, the transducer should be recalibrated or replaced.

**IMPORTANT: Whenever the oil pressure or the cooler pressure transducer is calibrated, the other sensor should be calibrated to prevent problems with oil differential pressure readings.**

Calibration can be checked by comparing the pressure readings from the transducer against an accurate refrigeration gage. These readings are all viewed or calibrated from the Status01 table on the LID. The transducer can be checked and calibrated at 2 pressure points. These calibration points are 0 psig (0 kPa) and between 240 and 260 psig (1655 to 1793 kPa). To calibrate these transducers:

1. Shut down the compressor.
2. Disconnect the transducer in question from its Schrader fitting.

**Note:** If the cooler or condenser vessels are at 0 psig (0 kPa) or are open to atmospheric pressure, the transducers can be calibrated for zero without removing the transducer from the vessel.

3. Access the Status01 table, and view the particular transducer reading; it should read 0 psi (0 kPa). If the reading is not 0 psi (0 kPa), but within  $\pm$  5 psi (35 kPa), the value may be zeroed by pressing the SELECT softkey while the highlight bar is located on the transducer, and then by pressing the ENTER. The value will now go to zero.



If the transducer value is not within the calibration range, the transducer will return to the original reading. If the LID pressure value is within the allowed range (noted above), check the voltage ratio of the transducer. To obtain the voltage ratio, divide the voltage (dc) input from the transducer by the supply voltage signal, measured at the PSIO terminals J7-J34 and J7-J35. For example, the condenser transducer voltage input is measured at PSIO terminals J7-1 and J7-2. The voltage ratio must be between 0.80 vdc and 0.11 vdc for the software to allow calibration. Pressurize the transducer until the ratio is within range. Then attempt calibration again.

4. A high pressure point can also be calibrated between 240 and 260 psig (1655 and 1793 kPa) by attaching a regulated 250 psig (1724 kPa) pressure (usually from a nitrogen cylinder). The high pressure point can be calibrated by accessing the transducer on the Status01 screen, highlighting the transducer, pressing the SELECT softkey, and then increasing or decreasing the value to the exact pressure on the refrigerant gage. Press ENTER to finish. High altitude locations must compensate the pressure so that the temperature/pressure relationship is correct.

If the transducer reading returns to the previous value and the pressure is within the allowed range, check the voltage ratio of the transducer. Refer to Step 3 above. The voltage ratio for this high pressure calibration must be between 0.585 and 0.634 vdc to allow calibration. Change the pressure at the transducer until the ratio is within the acceptable range. Then attempt calibrate to the new pressure input.





The PIC will not allow calibration if the transducer is too far out of calibration. A new transducer must be installed and recalibrated.

## Transducer Replacement

Since the transducers are mounted on Schrader-type fittings, there is no need to remove refrigerant from the vessel. Disconnect the transducer wiring by pulling up on the locking tab while pulling up on the weather-tight connecting plug from the end of the transducer. *Do not pull on the transducer wires.* Unscrew the transducer from the Schrader fitting. When installing a new transducer, do not use pipe sealer, which can plug the sensor. Put the plug connector back on the sensor and snap into place. Check for refrigerant leaks.

**WARNING**



**WARNING**

**Make sure to use a backup wrench on the Schrader fitting whenever removing a transducer.**



## Control Algorithms Checkout Procedure

In the LID Service menu, one of the tables is Control Algorithm Status. This table contains 4 maintenance tables which may be viewed in order to see how the particular control algorithm is operating. The 4 tables are:

<b>MAINT01</b>	Capacity Control	This table shows all values that are used to calculate the chilled water/brine control point.
<b>MAINT02</b>	Override Status	Details of all chilled water control override values are viewed here.
<b>MAINT03</b>	Surge/HGBP Status	The surge and hot gas bypass control algorithm status is viewed from this screen. All values dealing with this control are displayed.
<b>MAINT04 (PSIO Software Version 09 and Higher)</b>	LEAD/LAG Status	This screen indicates LEAD/LAG operation status.
<b>OCCDEFM</b>	Time Schedules Status	The Local and CCN occupied schedules are displayed here in a manner that the operator can quickly determine whether the schedule is in the OCCUPIED mode or not.
<b>WSMDEFME</b>	Water System Manager Status	The water system manager is a CCN module which can turn on the chiller and change the chilled water control point. This screen indicates the status of this system.

These maintenance tables are very useful in determining how the control temperature is calculated, guide vane position, reaction from load changes, control point overrides, hot gas bypass reaction, surge prevention, etc.



## Control Test

The Control Test feature can check all of the thermistor temperature sensors, including those on the Options modules, pressure transducers, pumps and their associated flow switches, the guide vane actuator, and other control outputs, such as hot gas bypass. The tests can help to determine whether a switch is defective, or a pump relay is not operating, among other useful troubleshooting tests. During pumpdown operations, the pumps are energized to prevent freeze-up and the vessel pressures and temperatures are displayed. The lockout feature will prevent start-up of the compressor when no refrigerant is present in the machine, or if the vessels are isolated. The lockout is then terminated by the operator by using the Terminate Lockout function after the pumpdown procedure is reversed and refrigerant is added.

### **Table 10, A - N — LID Primary and Secondary Messages and Custom Alarm/Alert Messages with Troubleshooting Guides**

[Click here for Table 10A — Shutdown with ON/OFF/RESET-OFF](#)

[Click here for Table 10B — Timing Out or Timed Out](#)



[Click here for Table 10C — In Recycle Shutdown](#)

[Click here for Table 10D — Pre-Start Alerts](#)

[Click here for Table 10E — Normal or Auto.-Restart](#)

[Click here for Table 10F — Start-Up Failures](#)

[Click here for Table 10G — Compressor Jumpstart and Refrigerant Protection](#)

[Click here for Table 10H — Normal Run with Reset, Temperature, or Demand](#)



[Click here for Table 10I — Normal Run Overrides Active \(Alerts\)](#)

[Click here for Table 10J — Out-of-Range Sensor Failures](#)

[Click here for Table 10K — Machine Protect Limit Faults](#)

[Click here for Table 10L — Machine Alerts](#)

[Click here for Table 10M — Spare Sensor Alert Messages](#)

[Click here for Table 10N — Other Problems/Malfunctions](#)



[Click here for Table 11A — Thermistor Temperature \(F\) vs Resistance/Voltage Drop](#)

[Click here for Table 11B — Thermistor Temperature \(C\) vs Resistance/Voltage Drop](#)

## Control Modules

**CAUTION**



**CAUTION**

**Turn controller power off before servicing controls. This ensures safety and prevents damage to controller.**

The Processor module (PSIO), 8-input (Options) modules, Starter Management Module (SMM), and the Local Interface Device (LID) module perform continuous diagnostic evaluations of the hardware to determine its condition. Proper operation of all modules is indicated by LEDs (light-emitting diodes) located on the side of the LID, and on the top horizontal surface of the PSIO, SMM, and 8-input modules.

[Contents](#)

## Red Led

If the LED is blinking continuously at a 2-second rate, it is indicating proper operation. If it is lit continuously it indicates a problem requiring replacement of the module. Off continuously indicates that the power should be checked. If the red LED blinks 3 times per second, a software error has been discovered and the module must be replaced. If there is no input power, check fuses and the circuit breaker. If fuse is good, check for shorted secondary of transformer, or if power is present to the module, replace the module.

## Green LEDs

There are one or 2 green LEDs on each type of module. These LEDs indicate communication status between different parts of the controller and the network modules as follows:

### LID Module

*Upper LED* — Communication with CCN network, if present; blinks when communication occurs.

*Lower LED* — Communication with PSIO module; must blink every 5 to 8 seconds when the LID default screen is displayed.



## **PSIO Module**

*Green LED closest to communications connection* — Communication with SMM and 8-input module; must blink continuously.

*Other Green LED* — Communication with LID; must blink every 3 to 5 seconds.

## **8-Input Modules and SMM**

*Green LED* — Communication with PSIO module; will blink continuously.





## Notes on Module Operation

1. The machine operator monitors and modifies configurations in the microprocessor through the 4 softkeys and the LID. Communication with the LID and the PSIO is accomplished through the CCN bus. The communication between the PSIO, SMM, and both 8-input modules is accomplished through the sensor bus, which is a 3-wire cable.  
On sensor bus terminal strips, Terminal 1 of PSIO module is connected to Terminal 1 of each of the other modules. Terminals 2 and 3 are connected in the same manner. See [Figure 41](#), [Figure 42](#), [Figure 43](#), [Figure 44](#), and [Figure 45](#). If a Terminal 2 wire is connected to Terminal 1, the system does not work.
2. If a green LED is solid on, check communication wiring. If a green LED is off, check the red LED operation. If the red LED is normal, check the module address switches ([Figure 41](#), [Figure 42](#), [Figure 43](#), [Figure 44](#), and [Figure 45](#)). Proper addresses are:

Module	Address	
	SW1	SW2
<b>SMM (Starter Management Module)</b>	3	2
<b>8-input Options Module 1</b>	6	4
<b>8-input Options Module 2</b>	7	2



If all modules indicate communications failure, check communications plug on the PSIO module for proper seating. Also check the wiring (CCN bus — 1:red, 2:wht, 3:blk; Sensor bus — 1:red, 2:blk, 3:clr/wht). If a good connection is assured and the condition persists, replace the PSIO module.

If only one 8-input module or SMM indicates communication failure, check the communications plug on that module. If a good connection is assured and the condition persists, replace the module.

All system operating intelligence rests in the PSIO module. Some safety shutdown logic resides in the SMM in case communications are lost between the 2 modules. The PSIO monitors conditions using input ports on the PSIO, the SMM, and the 8-input modules. Outputs are controlled by the PSIO and SMM as well.

### **3. Power is supplied to modules within the control panel via 21-vac power sources.**

The transformers are located within the power panel, with the exception of the SMM, which operates from a 24-vac power source and has its own 24-vac transformer located within the starter.

Within the power panel, T1 supplies power to the LID, the PSIO, and the 5-vac power supply for the transducers. The other 21-vac transformer is T4, which supplies power to both 8-input modules (if present). T4 is capable of supplying power to two modules; if additional modules are added, another power supply will be required. Power is connected to Terminals 1 and 2 of the power input connection on each module.



[Click here for Figure 41 — PSIO Module Address Selector Switch Locations and LED Locations](#)

[Click here for Figure 42 — LID Module \(Rear View\) and LED Locations](#)

## **Processor Module (PSIO) (Figure 43)**

### **Inputs**

Each input channel has 3 terminals; only 2 of the terminals are used. Application of machine determines which terminals are normally used. Always refer to individual unit wiring for terminal numbers.

### **Outputs**

Output is 20 vdc. There are 3 terminals per output, only 2 of which are used, depending on the application. Refer to the unit wiring diagram.

[Click here for Figure 43 — Processor \(PSIO\) Module](#)



## Starter Management Module (SMM) (Figure 44)

### Inputs

Inputs on strips J2 and J3 are a mix of analog and discrete (on/off) inputs. Application of the machine determines which terminals are used. Always refer to the individual unit wiring diagram for terminal numbers.

### Outputs

Outputs are 24 vdc and wired to strip J1. There are 2 terminals used per output.

[Click here for Figure 44 — Starter Management Module \(SSM\)](#)



## Options Modules (8-Input)

The options modules are optional additions to the PIC, and are used to add temperature reset inputs, spare sensor inputs, and demand limit inputs. Each option module contains 8 inputs, each input meant for a specific duty. See the wiring diagram for exact module wire terminations. Inputs for each of the options modules available include the following:

### Option Module 1

- 4 to 20 mA Auto. Demand Reset
- 4 to 20 mA Auto. Chilled Water Reset
- Common Chilled Water Supply Temperature
- Common Chilled Water Return Temperature
- Remote Temperature Reset Sensor
- Spare Temperature 1
- Spare Temperature 2
- Spare Temperature 3

### Option Module 2

- 4 to 20 mA Spare 1
- 4 to 20 mA Spare 2
- Spare Temperature 4
- Spare Temperature 5
- Spare Temperature 6
- Spare Temperature 7
- Spare Temperature 8
- Spare Temperature 9



Terminal block connections are provided on the options modules. All sensor inputs are field wired and installed. Options module number 1 can be factory or field-installed. Options module 2 is shipped separately and must be field installed. For installation, refer to the unit or field wiring diagrams. Be sure to address the module for the proper module number ([Figure 45](#)) and to configure the chiller for each feature being used.

[Click here for Figure 45 — Options Module](#)

## Replacing Defective Processor Modules

The replacement part number is printed in a small label on front of the PSIO module. The model and serial numbers are printed on the unit nameplate located on an exterior corner post. The proper software is factory-installed by Carrier in the replacement module. When ordering a replacement processor module (PSIO), specify complete replacement part number, full unit model number, and serial number. This new unit requires reconfiguration to the original machine data by the installer. Follow the procedures described in the [Set Up Machine Control Configuration](#) section.

**CAUTION**



**CAUTION**

**Electrical shock can cause personal injury. Disconnect all electrical power before servicing.**



## Installation

1. Verify if the existing PSIO module is defective, by using the procedure described in the [Troubleshooting Guide](#) section, and [Control Modules](#) section. Do not select the Attach to Network Device table if the LID displays communication failure.
2. Data regarding the PSIO configuration should have been recorded and saved. This data will have to be reconfigured into the LID. If this data is not available, follow the procedures described in the [Set Up Machine Control Configuration](#) section.

If a CCN Building Supervisor or Service Tool is present, the module configuration should have already been uploaded into memory; then, when the new module is installed, the configuration can be downloaded from the computer.

Any communication wires from other machines or CCN modules should be disconnected to prevent the new PSIO module from uploading incorrect run hours into memory.

3. Check that all power to the unit is off. Carefully disconnect all wires from the defective module by unplugging the 6 connectors. It is not necessary to remove any of the individual wires from the connectors.
4. Remove defective PSIO by removing its mounting screw with a long-shaft Phillips screwdriver, and removing the module from the control box. Save the screw for later use. The green ground wire is held in place with the module mounting screw.
5. Package the defective module in the carton of the new module for return to Carrier.



6. Mount the new module in the unit control box using a long-shaft Phillips screwdriver and the screw saved in Step 4 above. Make sure that the green grounding wire is reinstalled along with the mounting screw.
7. Connect the LID communication wires (CCN bus) and the power wires. If CCN wiring has been attached to the CCN bus, disconnect the wires. Attach the sensor bus plug and the input and output plugs.
8. Carefully check all wiring connections before restoring power.
9. Restore control power and verify that the red and green LEDs on the PSIO are functioning properly.
10. Access the Attach to Network Device table on the LID Service menu. Set the local device address to Bus 0, Address 90. Press the ATTACH softkey to upload the PSIO into the LID.
11. Change the address of the PSIO in the Controller Identification table back to the previous value. Write the address on the PSIO.
12. Use the configuration sheets to input setpoint, configuration, and schedule information into the PSIO. The Time and Date table also must be set. A Building Supervisor can be used to download, the old configuration into the PSIO.
13. Perform a Control Test and verify all tests.

If the software version has been updated, a CCN download of the configuration will not be allowed. Configure the PSIO by hand, and upload the PSIO into the network by using the Attach to Network Device table.





14. Restore chiller to normal operation, calibrate motor amps.

## Solid-State Starters

Troubleshooting guides and information pertaining to the operation of the solid-state starter may be found in [Figure 46](#), [Figure 47](#), [Figure 48](#), [Figure 49](#), [Figure 50](#), [Figure 51](#), [Figure 52](#), [Table 12](#), and [Table 13](#).

Attempt to solve the problem by using the following preliminary checks before consulting the troubleshooting tables.

When the power is off:

- Inspect for physical damage and signs of arcing, overheating, etc.
- Is the wiring to the starter correct?
- Are all connections in the starter tight?
- Is the current feedback resistor properly adjusted and installed?
- Is a heater coil installed in each leg of the motor?
- Is the control transformer fuse blown?
- Is the motor connected to the starter?

## Testing Silicon Control Rectifiers in Benschaw, Inc. Solid-State Starters

If a silicon control rectifier (SCR) is suspected of being defective, use the following procedure as part of a general troubleshooting guide.



**IMPORTANT: Before performing the SCR check below, remove power from the starter and disconnect the motor terminals T1, T2, and T3.**

1. Connect ohmmeter across terminals L1 and T1. Resistance reading should be greater than 50,000 ohms.
2. If reading is less than 50,000 ohms, remove connecting bus heatsink between SCR3 and SCR6 and check anode to cathode of SCR3 and SCR6 separately to determine which device is defective. See [Figure 46](#). Replace defective device and retest controller.
3. Repeat Steps 1 and 2 across terminals L2 and T2 for SCRs 2 and 5.
4. Repeat Steps 1 and 2 across terminals L3 and T3 for SCRs 1 and 4.

If the SCRs tested were not defective but the problem still persists, refer to the following Steps 5 and 6.

5. Disconnect the SCR1 from the white gate and red cathode wires on the AK control logic card. With an ohmmeter set on Rx1, check between white and red wires. Resistance should normally be between 8 and 20 ohms average. Excessively high or low resistance may be indicative of a defective device. Replace and retest.
6. Repeat Step 5 for SCR leads 2 through 6. Care should be taken to ensure that the gate and cathode wires are replaced exactly as they were: white wire to gate (G1 through G6); red wire to cathode (K1 through K6).



**CAUTION**



**CAUTION**

**Damage to the starter may result if wires are reversed.**

If problem is still not resolved, consult the starter manufacturer for servicing.

## **Testing Silicon Control Rectifiers (SCRs) in Cutler-Hammer® Solid-State Starters**

To check for a shorted SCR refer to Steps 1-3 and [Figure 47](#), [Figure 48](#), and [Figure 49](#).

**Note:** Do not megger (high voltage insulation test) the starter.

1. Connect ohmmeter across terminals L1 and T1. Check the resistance reading. Resistance reading should be greater than 10,000 ohms.

[Click here for Figure 46 — Typical Benshaw, Inc. Solid-State Starter \(Internal View\)](#)

2. Connect ohmmeter across terminals L2 and T2. Check the resistance reading. Resistance reading should be greater than 10,000 ohms.
3. Connect ohmmeter across terminals L3 and T3. Check the resistance reading. Resistance reading should be greater than 10,000 ohms.

If the SCRs tested were not defective, but the problem persists, refer to Steps 4-8.



4. Connect the T1, T2, and T3 terminals on the starter to the motor.
5. Disconnect one of the wires to the shunt trip contact on the starter. This wire is disconnected to prevent the shorted SCR detection from operating the disconnect device while this test is being performed.
6. Close the disconnect breaker. Check the voltage from the starter line terminal to load terminal on each phase. The measured voltage should be approximately 0.58 times the system line-to-line voltage.

If the voltage on any power pole is significantly less, one or both SCRs in the power pole may be shorted. See [Figure 48](#).

7. If a shorted SCR is detected, check for possible shorted connections, system grounds, or any other condition that might be causing the short. Replacement of SCRs or power poles without determining the cause of the failure may result in repeated failure of the SCRs.
8. When the starter is running, measure the voltage from the line side to the load side of each starter power pole. The voltage should be approximately 1 to 1.5 vac.

**DANGER**



**DANGER**

**When measuring voltage from line side to load side, observe proper electrical safety procedures since the power poles have voltage applied. This voltage could be as high as 600 v. Personal injury could result.**



If one of the voltages is higher than 2 v, but the voltages of the 3 power poles are approximately equal, the starter is probably still in current limit. If the voltage is higher than 2 v on only 1 or 2 power poles, not all SCRs are firing properly. Make sure the gate lead connections are tight. If all 3 power poles have less than a 2 v drop from line side to load side of each starter power pole when the motor is up to speed, any current unbalance in the motor is caused by the motor or an unbalanced line voltage.

[Click here for Figure 47 — Resistance Check](#)

[Click here for Figure 48 — SCR and Power Poles](#)

[Click here for Figure 49 — Typical Cutler-Hammer® Solid-State Starter \(Internal View\)](#)

### **Electronic Protection Relay (EPR)**

On Cutler-Hammer solid-state starters, the EPR is designed to provide an alternative to conventional motor protection due to overcurrent. See [Figure 50](#). It performs the following functions:

*Test Button* — The TEST button provides testing of the EPR's ability to detect overload, test relay operation, and simulate motor load.



*System Ready (SYST RDY)* — This light-emitting diode (LED) provides a visual indication that the EPR is functioning.

*Trip Time Potentiometer* — The Trip Time potentiometer has 50 selectable overload trip classes ranging from 1 to 50 seconds.

*Reset Time Potentiometer* — The Reset Time potentiometer has 5 to 120 minutes of motor cooling reset.

*Full Load Amperes (FLA)* — The FLA potentiometer is adjustable from 1 to 1,500 amps, based on overload frame size.

*Trip LED* — The Trip LED provides a visual indication that the EPR has detected an overload condition and tripped.

*Fault (FLT) LED* — The FLT LED is an indicator light.

*Reset Button* — The RESET button allows for the manual reset of the EPR.

*Trip, Common (COM), and FLA Test Terminals* — The Trip, COM, and FLA test terminals provide for Digital Voltmeter (DVM) calibration.

*Terminal 1 (TB1)* — Terminal 1 is the 120 vac connection to power the EPR.

*Terminal 4 (TB4)* — Terminal 4 is the normally closed, electronically isolated EPR contact for overload trip.

**Note:** When the System Ready (SYST RDY) LED is a steady green light, no fault has been found in the solid-state starter operation. When the SYST RDY LED is a steady green



light and the fault indicator (FLT) is a flashing red light, the a motor overload trip is approaching. When the FLT LED is a solid red light and the SYST RDY LED is a flashing green light, a motor overload trip has occurred. When the FLT LED is a solid red light and the SYST RDY LED is a solid green light, the overload has tripped because of a phase unbalance.

[Click here for Figure 50 — Cutler-Hammer® Terminal Functions](#)

[Click here for Figure 51 — Solid-State Starter, General Operation Troubleshooting Guide \(Typical\)](#)

[Click here for Figure 52 — Solid-State Starter, Starter Fault \(Motor Will Not Start\) Troubleshooting Guide \(Typical\)](#)

[Click here for Table 12 — Benshaw, Inc. Solid-State Starter Troubleshooting Guide](#)



[Click here for Table 13 — Cutler-Hammer® Solid-State Starter Troubleshooting Guide](#)

## Physical Data

[Table 14](#), [Table 15](#), [Table 16](#), [Table 17](#), [Table 18](#), [Table 19](#), [Figure 53](#), [Figure 54](#), [Figure 55](#), [Figure 56](#), [Figure 57](#), and [Figure 58](#) provide additional information regarding compressor fits and clearances, physical and electrical data, and wiring schematics for operator convenience during troubleshooting.

[Click here for Table 14 — Heat Exchanger Data](#)

[Click here for Table 15 — Additional Data for Marine Waterboxes](#)

[Click here for Table 16 — Compressor Weights](#)





[Click here for Table 17 — Compressor/Motor Weights](#)

[Click here for Table 18 — Waterbox Cover Weights](#)

[Click here for Table 19 — Optional Pumpout System Electrical Data](#)

[Click here for Figure 53 — Compressor Fits and Clearances](#)

[Click here for Figure 54 — Compressor Fits and Clearances \(continued\)](#)

[Click here for Figure 55 — Compressor Fits and Clearances \(continued\)](#)



[Click here for Figure 56 — Electronic PIC Controls Wiring Schematic](#)

[Click here for Figure 57 — Machine Power Panel, Starter Assembly, and Motor Wiring Schematic](#)

[Click here for Figure 58 — Typical Wye-Delta Unit Mounted Starter Wiring Schematic](#)



**Table 1 — Major PIC Components and Panel Locations\***

Pic Component	Panel Location
<b>Processor Sensor Input/Output Module (PSIO)</b>	Control Center
<b>Starter Management Module (SMM)</b>	Starter Cabinet
<b>Local Interface Device (LID)</b>	Control Center
<b>6-Pack Relay Board</b>	Control Center
<b>8-Input Modules (Optional)</b>	Control Center
<b>Oil Heater Contactor (1C)</b>	Power Panel
<b>Oil Pump Contactor (2C)</b>	Power Panel
<b>Hot Gas Bypass Relay (3C) (Optional)</b>	Power Panel
<b>Control Transformers (T1-T4)</b>	Power Panel
<b>Control and Oil Heater Voltage Selector (S1)</b>	Power Panel
<b>Temperature Sensors</b>	See <a href="#">Figure 8</a>
<b>Pressure Transducers</b>	See <a href="#">Figure 8</a>

\*See [Figure 5](#), [Figure 6](#), [Figure 8](#), [Figure 9](#), [Figure 10](#), [Figure 11](#), and [Figure 12](#).



## Table 2 — LID Screens

### Notes:

1. Only 12 lines of information appear on the LID screen at any given time. Press **NEXT** or **PREVIOUS** to highlight a point or to view points below or above the current screen.
2. The LID may be configured in English or SI units, as required, through the LID configuration screen.
3. Data appearing in the Reference Point Names column is used for CCN operations only.
4. All options associated with ICE BUILD, Lead/Lag, CCN Occupancy Configuration, and Soft Stopping are only available on PSIO Software Version 9 and higher.

### Example 1 — Status01 Display Screen

To access this display from the **LID default** screen:

1. Press **MENU**.
2. Press **STATUS** (**STATUS01** will be highlighted).
3. Press **SELECT**.

**Table 2, Example 1 — Status01 Display Screen**

Description	Range	Units	Reference Point Name (Alarm History)
<b>Control Mode</b>	Reset.Off.Local.CCN		MODE
<b>Run Status</b>	Timeout.Recycle.Startup. Ramping.Running.Demand. Override.Shutdown.Abnormal. Pumpdown		STATUS
<b>Occupied?</b>	No/Yes		OCC
<b>Alarm State</b>	Normal/Alarm		ALM
<b>*Chiller Start/Stop</b>	Stop/Start		CHIL_S_S
<b>Base Demand Limit</b>	40-100	%	DLM
<b>*Active Demand Limit</b>	40-100	%	DEM_LIM
<b>Compressor Motor Load</b>	0-999	%	CA_L
<b>Current</b>	0-999	%	CA_P
<b>Amps</b>	0-999	AMPS	CA_A
<b>*Target Guide Vane Pos</b>	0-100	%	GV_TRG
<b>Actual Guide Vane Pos</b>	0-100	%	GV_ACT
<b>Water/Brine: Setpoint</b>	10-120 (-12.2-48.9)	DEG F (DEG C)	SP
<b>* Control Point</b>	10-120 (-12.2-48.9)	DEG F (DEG C)	LCW_STPT





**Table 2, Example 1 — Status01 Display Screen (Continued)**

Description	Range	Units	Reference Point Name (Alarm History)
Entering Chilled Water	-40-245 (-40-118)	DEG F (DEG C)	ECW
Leaving Chilled Water	-40-245 (-40-118)	DEG F (DEG C)	LCW
Entering Condenser Water	-40-245 (-40-118)	DEG F (DEG C)	ECDW
Leaving Condenser Water	-40-245 (-40-118)	DEG F (DEG C)	LCDW
Evaporator Refrig Temp	-40-245 (-40-118)	DEG F (DEG C)	ERT
Evaporator Pressure	-6.7-420 (-46-2896)	PSI (kPa)	ERP
Condenser Refrig Temp	-40-245 (-40-118)	DEG F (DEG C)	CRT
Condenser Pressure	-6.7-420 (-46-2896)	PSI (kPa)	CRP
Discharge Temperature	-40-245 (-40-118)	DEG F (DEG C)	CMPD
Bearing Temperature	-40-245 (-40-118)	DEG F (DEG C)	MTRB
Motor Winding Temp	-40-245 (-40-118)	DEG F (DEG C)	MTRW
Oil Sump Temperature	-40-245 (-40-118)	DEG F (DEG C)	OILT
Oil Pressure Transducer	-6.7-420 (-46-2896)	PSI (kPa)	OILP
Oil Pressure	-6.7-420 (-46-2896)	PSID (kPad)	OILPD
Line Voltage: Percent	0-999	%	V_P
Actual	0-9999	VOLTS	V_A
*Remote Contacts Input	Off/On		REMCON
Total Compressor Starts	0-65535		c_starts
Starts in 12 Hours	0-8		STARTS
Compressor Ontime	0-500000.0	HOURS	c_hrs
*Service Ontime	0-32767	HOURS	S_HRS
*Compressor Motor kW	0-9999	kW	CKW

**Note:** All values are variables available for read operation to a CCN. Descriptions shown with (\*) support write operations for BEST programming language, data-transfer, and overriding.





## Example 2 — Status02 Display Screen

To access this display from the **LID default** screen:

1. Press **MENU**.
2. Press **STATUS**.
3. Scroll down to highlight **STATUS02**.
4. Press **SELECT**.

**Table 2, Example 2 — Status02 Display Screen**

Description	Point Type		Units	Reference Point Name (Alarm History)
	Input	Output		
Hot Gas Bypass Relay		X	OFF/ON	HGBR
*Chilled Water Pump		X	OFF/ON	CHWP
Chilled Water Flow	X		NO/YES	EVFL
*Condenser Water Pump		X	OFF/ON	CDP
Condenser Water Flow	X		NO/YES	CDFL
Compressor Start Relay		X	OFF/ON	CMPR
Compressor Start Contact	X		OPEN/CLOSED	1CR_AUX
Compressor Run Contact	X		OPEN/CLOSED	RUN_AUX
Starter Fault Contact	X		OPEN/CLOSED	STR_FLT
Pressure Trip Contact	X		OPEN/CLOSED	PRS_TRIP
Single Cycle Dropout	X		NORMAL/ALARM	V1_CYCLE
Oil Pump Relay		X	OFF/ON	OILR
Oil Heater Relay		X	OFF/ON	OILH
Motor Cooling Relay		X	OFF/ON	MTRC
*Tower Fan Relay		X	OFF/ON	TFR
Compr. Shunt Trip Relay		X	OFF/ON	TRIPR
Alarm Relay		X	NORMAL/ALARM	ALM
Spare Prot Limit Input	X		ALARM/NORMAL	SPR_PL

**Note:** All values are variables available for read operation to a CCN. Descriptions shown with (\*) support write operations from the LID only.





### Example 3 — Status03 Display Screen

To access this display from the **LID default** screen:

1. Press **MENU**.
2. Press **STATUS**.
3. Scroll down to highlight **STATUS03**.
4. Press **SELECT**.

**Table 2, Example 3 — Status03 Display Screen**

Description	Range	Units	Reference Point Name (Alarm History)
<b>OPTIONS BOARD 1</b>			
*Demand Limit 4-20 mA	4-20	mA	DEM_OPT
*Temp Reset 4-20 mA	4-20	mA	RES_OPT
*Common CHWS Sensor	-40-245 (-40-118)	DEG F (DEG C)	CHWS
*Common CHWR Sensor	-40-245 (-40-118)	DEG F (DEG C)	CHWR
*Remote Reset Sensor	-40-245 (-40-118)	DEG F (DEG C)	R_RESET
*Temp Sensor — Spare 1	-40-245 (-40-118)	DEG F (DEG C)	SPARE1
*Temp Sensor — Spare 2	-40-245 (-40-118)	DEG F (DEG C)	SPARE2
*Temp Sensor — Spare 3	-40-245 (-40-118)	DEG F (DEG C)	SPARE3
<b>OPTIONS BOARD 2</b>			
*4-20 mA — Spare 1	4-20	mA	SPARE1_M
*4-20 mA — Spare 2	4-20	mA	SPARE2_M
*Temp Sensor — Spare 4	-40-245 (-40-118)	DEG F (DEG C)	SPARE4
*Temp Sensor — Spare 5	-40-245 (-40-118)	DEG F (DEG C)	SPARE5
*Temp Sensor — Spare 6	-40-245 (-40-118)	DEG F (DEG C)	SPARE6
*Temp Sensor — Spare 7	-40-245 (-40-118)	DEG F (DEG C)	SPARE7
*Temp Sensor — Spare 8	-40-245 (-40-118)	DEG F (DEG C)	SPARE8
*Temp Sensor — Spare 9	-40-245 (-40-118)	DEG F (DEG C)	SPARE9

**Note:** All values shall be variables available for read operation to a CCN network. Descriptions shown with (\*) support write operations for BEST programming language, data-transfer, and overriding.





## Example 4 — Setpoint Display Screen

To access this display from the **LID default** screen:

1. Press **MENU**.
2. Press **SETPOINT**.

**Table 2, Example 4 — Setpoint Display Screen**

Description	Configurable Range	Units	Reference Point Name	Default Value
<b>Base Demand Limit</b>	40-100	%	DLM	100
<b>LCW Setpoint</b>	20-120 (-6.7-48.9)	DEG F (DEG C)	lcw_sp	50.0 (10.0)
<b>ECW Setpoint</b>	20-120 (-6.7-48.9)	DEG F (DEG C)	ecw_sp	60.0 (15.6)
<b>ICE BUILD Setpoint</b>	20- 60 (-6.7-15.6)	DEG F (DEG C)	ice_sp	40.0 ( 4.4)







## Example 5 — Configuration (Config) Display Screen

To access this display from the **LID default** screen:

1. Press **MENU**.
2. Press **SERVICE**.
3. Scroll down to highlight **EQUIPMENT CONFIGURATION**.
4. Press **SELECT**.
5. Scroll down to highlight **CONFIG**.
6. Press **SELECT**.

**Table 2, Example 5 — Configuration (Config) Display Screen**

Description	Configurable Range	Units	Reference Point Name	Default Value
<b>RESET TYPE 1</b> Degrees Reset at 20 mA	-30-30 (-17-17)	DEG F (DEG C)	deg_20ma	10Δ(6Δ)
<b>RESET TYPE 2</b> Remote Temp (No Reset)	-40-245 (-40-118)	DEG F (DEG C)	res_rt1	85 (29)
Remote Temp (Full Reset)	-40-245 (-40-118)	DEG F (DEG C)	res_rt2	65 (18)
Degrees Reset	-30-30 (-17-17)	DEG F (DEG C)	res_rt	10Δ (6Δ)
<b>RESET TYPE 3</b> CHW Delta T (No Reset)	0-15 (0-8)	DEG F (DEG C)	restd_1	10Δ (6Δ)
CHW Delta T (Full Reset)	0-15 (0-8)	DEG F (DEG C)	restd_2	0Δ (-0Δ)
Degrees Reset	-30-30 (-17-17)	DEG F (DEG C)	deg_chw	5Δ (3Δ)
Select/Enable Reset Type	0-3		res_sel	0
<b>ECW CONTROL OPTION</b> Demand Limit At 20 mA	DISABLE/ENABLE		ecw_opt	DISABLE
20mA Demand Limit Option	40-100	%	dem_20ma	40
Auto Restart Option	DISABLE/ENABLE		dem_sel	DISABLE
Remote Contacts Option	DISABLE/ENABLE		astart	DISABLE
Temp Pulldown Deg/Min	2-10		r_contact	DISABLE
Load Pulldown %/Min	5-20		tmp_ramp	3
Select Ramp Type:	0/1		kw_ramp	10
Temp = 0, Load = 1			ramp_opt	1
Loadshed Group Number	0-99		ldsgrp	0
Loadshed Demand Delta	0-60	%	ldsdelta	20
Maximum Loadshed Time	0-120	MIN	maxldstm	60
<b>CCN Occupancy Config:</b> Schedule Number	3-99		occpcxxe	3
Broadcast Option	DISABLE/ENABLE		occbrcst	DISABLE
<b>ICE BUILD Option</b> ICE BUILD TERMINATION	DISABLE/ENABLE		ibopt	DISABLE
0 =Temp, 1 =Contacts, 2 =Both	0-2		ibterm	0
ICE BUILD Recycle Option	DISABLE/ENABLE		ibrecyc	DISABLE

**Note:** Δ = delta degrees.





## Example 6 — Lead/Lag Configuration Display Screen

To access this display from the **LID default** screen:

1. Press **MENU**.
2. Press **SERVICE**.
3. Scroll down to highlight **EQUIPMENT CONFIGURATION**.
4. Press **SELECT**.
5. Scroll down to highlight **Lead/Lag**.
6. Press **SELECT**.

**Table 2, Example 6 — Lead/Lag Configuration Display Screen**

Description	Configurable Range	Units	Reference Point Name	Default Value
<b>LEAD/LAG SELECT</b> DISABLE =0, LEAD =1, LAG =2, STANDBY =3	0-3		leadlag	0
<b>Load Balance Option</b>	DISABLE/ENABLE		loadbal	DISABLE
<b>Common Sensor Option</b>	DISABLE/ENABLE		commsens	DISABLE
<b>LAG Percent Capacity</b>	25-75	%	lag_per	50
<b>LAG Address</b>	1-236		lag_add	92
<b>LAG START Timer</b>	2-60	MIN	lagstart	10
<b>LAG STOP Timer</b>	2-60	MIN	lagstop	10
<b>PRESTART FAULT Timer</b>	0-30	MIN	preflt	5
<b>STANDBY Chiller Option</b>	DISABLE/ENABLE		stndopt	DISABLE
<b>STANDBY Percent Capacity</b>	25-75	%	stnd_per	50
<b>STANDBY Address</b>	1-236		stnd_add	93

**Note:** The Lead/Lag Configuration table is available on PSIO Software Version 09 and higher.





### Example 7 — Service1 Display Screen

To access this display from the **LID default** screen:

1. Press **MENU**.
2. Press **SERVICE**.
3. Scroll down to highlight **EQUIPMENT SERVICE**.
4. Press **SELECT**.
5. Scroll down to highlight **SERVICE1**.
6. Press **SELECT**.

**Table 2, Example 7 — Service1 Display Screen**

Description	Configurable Range	Units	Reference Point Name	Default Value
<b>Motor Temp Override</b>	150-200 (66-93)	DEG F (DEG C)	mt_over	200 (93)
<b>Cond Press Override</b>	150-245 (1034-1689) [90-200 (620-1379)]	PSI (kPa)	cp_over	195 (1345) [125 (862)]
<b>Refrig Override Delta T</b>	2-5 (1-3)	DEG F (DEG C)	ref_over	3Δ (1.6Δ)
<b>Chilled Medium</b>	Water/Brine		medium	WATER
<b>Brine Refrig Trippoint</b>	8-40 (-13.3-4)	DEG F (DEG C)	br_trip	33 (1)
<b>Compr Discharge Alert</b>	125-200 (52-93)	DEG F (DEG C)	cd_alert	200 (93)
<b>Bearing Temp Alert</b>	175-185 (79-85)	DEG F (DEG C)	tb_alert	175 (79)
<b>Water Flow Verify Time</b>	0.5-5	MIN	wflow_t	5
<b>Oil Press Verify Time</b>	15-300	SEC	oilpr_t	15
<b>Water/Brine Deadband</b>	0.5-2.0 (0.3-1.1)	DEG F (DEG C)	cw_db	1.0 (0.6)
<b>Recycle Restart Delta T</b>	2.0-10.0 (1.1-5.6)	DEG F (DEG C)	rcyc_dt	5 (2.8)
<b>Surge Limit/HGBP Option</b>	0/1		srg_hgbp	0
<b>Select: Surge=0, HGBP=1</b>				
<b>Surge/HGBP Delta T1</b>	0.5-15 (0.3-8.3)	DEG F (DEG C)	hgb_dt1	1.5 (0.8)
<b>Surge/HGBP Delta P1</b>	50-170 (345-1172) [30-170 (207-1172)]	PSI (kPa)	hgb_dp1	75 (517) [50 (345)]
<b>Min. Load Points (T1/P1)</b>				
<b>Surge/HGBP Delta T2</b>	0.5-15 (0.3-8.3) 50-170 (345-1172)	DEG F (DEG C)	hgb_dt2	10 (5.6)





**Table 2, Example 7 — Service1 Display Screen (Continued)**

Description	Configurable Range	Units	Reference Point Name	Default Value
Surge/HGBP Delta P2 Full Load Points (T2/P2)	[30-170 (207-1172)]	PSI (kPa)	hgb_dp2	170 (1172) [85 (586)]
Surge/HGBP Deadband	1-3 (0.6-1.6)	DEG F (DEG C)	hgb_dp	1 (0.6)
Surge Delta Percent Amps	10-50	%	surge_a	25
Surge Time Period	1-5	MIN	surge_t	2
Demand Limit Source Select: Amps=0, Load=1	0/1		dem_src	0
Amps Correction Factor	1-8		corfact	3
Motor Rated Load Amps	1-9999	AMPS	a_fs	200
Motor Rated Line Voltage	1-9999	VOLTS	v_fs	460
Meter Rated Line KW	1-9999	kW	kw_fs	600
Line Frequency Select: 0=60 Hz, 1=50 Hz	0/1	HZ	freq	0
Compr Starter Type	REDUCE/FULL		starter	REDUCE
Condenser Freeze Point	-20-35 (-28.9-1.7)	DEG F (DEG C)	cdfreeze	34 (1)
Soft Stop Amps Threshold	40-100	%	softstop	100

**Note:**

1. Condenser Freeze Point and Softstop Amps Threshold are only selectable/readable on PSIO Software Versions 09 and higher.
2. Values in [ ] indicate HFC-134a values.
3. Δ = delta degrees.





### Example 8 — Service2 Display Screen

To access this display from the LID default screen:

1. Press **MENU**.
2. Press **SERVICE**.
3. Scroll down to highlight **EQUIPMENT SERVICE**.
4. Press **SELECT**.
5. Scroll down to highlight **SERVICE2**.
6. Press **SELECT**.

**Table 2, Example 8 — Service2 Display Screen**

Description	Configurable Range	Units	Reference Point Name	Default Value
<b>OPTIONS BOARD 1</b> <b>20 mA POWER CONFIGURATION</b> External = 0, Internal = 1 <b>RESET 20 mA Power Source DEMAND 20 mA Power Source</b> <b>SPARE ALERT ENABLE</b> Disable = 0, Low = 1, High = 2 <b>Temp = Alert Threshold</b>	DISABLE/ENABLE DISABLE/ENABLE		res_20 ma dem_20 ma	DISABLE DISABLE
<b>CHWS Temp Enable</b>	0-2		chws_en	0
<b>CHWS Temp Alert</b>	-40-245 (-40-118)	DEG F (DEG C)	chws_al	245 (118)
<b>CHWR Temp Enable</b>	0-2		chwr_en	0
<b>CHWR Temp Alert</b>	-40-245 (-40-118)	DEG F (DEG C)	chwr_al	245 (118)
<b>Reset Temp Enable</b>	0-2		rres_en	0
<b>Reset Temp Alert</b>	-40-245 (-40-118)	DEG F (DEG C)	rres_al	245 (118)
<b>Spare Temp 1 Enable</b>	0-2		spr1_en	0
<b>Spare Temp 1 Alert</b>	-40-245 (-40-118)	DEG F (DEG C)	spr1_al	245 (118)
<b>Spare Temp 2 Enable</b>	0-2		spr2_en	0
<b>Spare Temp 2 Alert</b>	-40-245 (-40-118)	DEG F (DEG C)	spr2_al	245 (118)
<b>Spare Temp 3 Enable</b>	0-2		spr3_en	0
<b>Spare Temp 3 Alert</b>	-40-245 (-40-118)	DEG F (DEG C)	spr3_al	245 (118)





**Table 2, Example 8 — Service2 Display Screen (Continued)**

Description	Configurable Range	Units	Reference Point Name	Default Value
<b>OPTIONS BOARD 2</b>				
<b>20 mA POWER CONFIGURATION External = 0, Internal = 1</b>				
<b>SPARE 1 20 mA Power Source</b>	DISABLE/ENABLE		sp1_20 ma	DISABLE
<b>SPARE 2 20 mA Power Source</b>	DISABLE/ENABLE		sp2_20 ma	DISABLE
<b>SPARE ALERT ENABLE</b>				
<b>Disable = 0, Low = 1, High = 2</b>				
<b>Temp = Alert Threshold</b>				
<b>Spare Temp 4 Enable</b>	0-2		spr4_en	0
<b>Spare Temp 4 Alert</b>	-40-245 (-40-118)	DEG F (DEG C)	spr4_al	245 (118)
<b>Spare Temp 5 Enable</b>	0-2		spr5_en	0
<b>Spare Temp 5 Alert</b>	-40-245 (-40-118)	DEG F (DEG C)	spr5_al	245 (118)
<b>Spare Temp 6 Enable</b>	0-2		spr6_en	0
<b>Spare Temp 6 Alert</b>	-40-245 (-40-118)	DEG F (DEG C)	spr6_al	245 (118)
<b>Spare Temp 7 Enable</b>	0-2		spr7_en	0
<b>Spare Temp 7 Alert</b>	-40-245 (-40-118)	DEG F (DEG C)	spr7_al	245 (118)
<b>Spare Temp 8 Enable</b>	0-2		spr8_en	0
<b>Spare Temp 8 Alert</b>	-40-245 (-40-118)	DEG F (DEG C)	spr8_al	245 (118)
<b>Spare Temp 9 Enable</b>	0-2		spr9_en	0
<b>Spare Temp 9 Alert</b>	-40-245 (-40-118)	DEG F (DEG C)	spr9_al	245 (118)

**Note:** This screen provides the means to generate alert messages based on exceeding the “Temp Alert” threshold for each point listed. If the “Enable” is set to 1, a value above the “Temp Alert” threshold shall generate an alert message. If the “Enable” is set to 2, a value below the “Temp Alert” threshold shall generate an alert message. If the “Enable” is set to 0, alert generation is disabled.





### Example 9 — Service3 Display Screen

To access this display from the **LID default** screen:

1. Press **MENU**.
2. Press **SERVICE**.
3. Scroll down to highlight **EQUIPMENT SERVICE**.
4. Press **SELECT**.
5. Scroll down to highlight **SERVICE3**.

**Table 2, Example 9 — Service3 Display Screen**

Description	Configurable Range	Units	Reference Point Name	Default Value
Proportional Inc Band	2-10		gv_inc	6.5
Proportional Dec Band	2-10		gv_de	6.0
Proportional ECW Gain	1-3		gv_ecw	2.0
Guide Vane Travel Limit	30-100	%	gv_lim	50





## Example 10 — Maintenance (Maint01) Display Screen

To access this display from the **LID default** screen:

1. Press **MENU**.
2. Press **SERVICE**.
3. Scroll down to highlight **ALGORITHM STATUS**.
4. Press **SELECT**.
5. Scroll down to highlight **MAINT01**.

**Table 2, Example 10 — Maintenance (Maint01) Display Screen**

Description	Range/Status	Units	Reference Point Name
<b>CAPACITY CONTROL</b>			
<b>Control Point</b>	10-120 (-12.2-48.9)	DEG F (DEG C)	ctrlpt
<b>Leaving Chilled Water</b>	-40-245 (-40-118)	DEG F (DEG C)	LCW
<b>Entering Chilled Water</b>	-40-245 (-40-118)	DEG F (DEG C)	ECW
<b>Control Point Error</b>	-99-99 (-55-55)	DEG F (DEG C)	cperr
<b>ECW Delta T</b>	-99-99 (-55-55)	DEG F (DEG C)	ecwdt
<b>ECW Reset</b>	-99-99 (-55-55)	DEG F (DEG C)	ecwres
<b>LCW Reset</b>	-99-99 (-55-55)	DEG F (DEG C)	lcwres
<b>Total Error + Resets</b>	-99-99 (-55-55)	DEG F (DEG C)	error
<b>Guide Vane Delta</b>	-2-2	%	gvd
<b>Target Guide Vane Pos</b>	0-100	%	GV_TRG
<b>Actual Guide Vane Pos</b>	0-100	%	GV_ACT
<b>Proportional Inc Band</b>	2-10		gv_inc
<b>Proportional Dec Band</b>	2-10		gv_dec
<b>Proportional ECW Gain</b>	1-3		gv_ecw
<b>Water/Brine Deadband</b>	0.5-2 (0.3-1.1)	DEG F (DEG C)	cwdb

**Note:** Overriding is not supported on this maintenance screen. Active overrides show the associated point in alert (\*). Only values with capital letter reference point names are variables available for read operation.







### Example 11 — Maintenance (Maint02) Display Screen

To access this display from the **LID default** screen:

1. Press **MENU**.
2. Press **SERVICE**.
3. Scroll down to highlight **CONTROL ALGORITHM STATUS**.
4. Press **SELECT**.
5. Scroll down to highlight **MAINT02**.
6. Press **SELECT**.

**Table 2, Example 11 — Maintenance (Maint02) Display Screen**

Description	Range/Status	Units	Reference Point Name
<b>OVERRIDE/ALERT STATUS</b>			
<b>MOTOR WINDING TEMP</b>	-40-245 (-40-118)	DEG F (DEG C)	MTRW
<b>Override Threshold</b>	150-200 (66-93)	DEG F (DEG C)	mt_over
<b>CONDENSER PRESSURE</b>	-6.7-420 (-42-2896)	PSI (kPa)	CRP
<b>Override Threshold</b>	90-245 (621-1689)	PSI (kPa)	cp_over
<b>EVAPORATOR REFRIG TEMP</b>	-40-245 (-40-118)	DEG F (DEG C)	ERT
<b>Override Threshold</b>	2-45 (1-7.2)	DEG F (DEG C)	rt_over
<b>DISCHARGE TEMPERATURE</b>	-40-245 (-40-118)	DEG F (DEG C)	CMPD
<b>Alert Threshold</b>	125-200 (52-93)	DEG F (DEG C)	cd_alert
<b>BEARING TEMPERATURE</b>	-40-245 (-40-118)	DEG F (DEG C)	MTRB
<b>Alert Threshold</b>	175-185 (79-85)	DEG F (DEG C)	tb_alert

**Note:** Overriding is not supported on this maintenance screen. Active overrides show the associated point in alert (\*). Only values with capital letter reference point names are variables available for read operation.





## Example 12 — Maintenance (Maint03) Display Screen

To access this display from the **LID default** screen:

1. Press **MENU**.
2. Press **SERVICE**.
3. Scroll down to highlight **CONTROL ALGORITHM STATUS**.
4. Press **SELECT**.
5. Scroll down to highlight **MAINT03**.
6. Press **SELECT**.

**Table 2, Example 12 — Maintenance (Maint03) Display Screen**

Description	Range/Status	Units	Reference Point Name
<b>SURGE/HGBP ACTIVE?</b>	NO/YES		
<b>Active Delta P</b>	0-200 (0-1379)	PSI (kPa)	dp_a
<b>Active Delta T</b>	0-200 (0-111)	DEG F (DEG C)	dt_a
<b>Calculated Delta T</b>	0-200 (0-111)	DEG F (DEG C)	dt_c
<b>Surge Protection Counts</b>	0-12		spc

**Note:** Override is not supported on this maintenance screen. Only values with capital letter reference point names are variables available for read operation.





### Example 13 — Maintenance (Maint04) Display Screen

To access this display from the **LID default** screen:

1. Press **MENU**.
2. Press **SERVICE**.
3. Scroll down to highlight **CONTROL ALGORITHM STATUS**.
4. Press **SELECT**.
5. Scroll down to highlight **MAINT04**.
6. Press **SELECT**.

**Table 2, Example 13 — Maintenance (Maint04) Display Screen**

Description	Range/Status	Units	Reference Point Name
<b>LEAD/LAG: Configuration</b>	DISABLE,LEAD,LAG,STANDBY, INVALID		leadlag
<b>Current Mode</b>	DISABLE,LEAD,LAG,STANDBY, CONFIG		llmode
<b>Load Balance Option</b>	DISABLE/ENABLE		loadbal
<b>LAG Start Time</b>	0-60	MIN	lagstart
<b>LAG Stop Time</b>	0-60	MIN	lagstop
<b>Prestart Fault Time</b>	0-30	MIN	preflt
<b>Pulldown: Delta T/Min</b>	x.xx	Δ DEG F (ΔDEG C)	pull_dt
<b>Satisfied?</b>	No/Yes		pull_sat
<b>LEAD CHILLER in Control</b>	No/Yes		leadctrl
<b>LAG CHILLER: Mode</b>	Reset,Off,Local,CCN		lagmode
<b>Run Status</b>	Timeout,Recycle,Startup,Ramping,Running Demand,Override,Shutdown,Abnor- mal,Pumpdown		lagstat
<b>Start/Stop</b>	Stop,Start,Retain		lag_s_s
<b>Recovery Start Request</b>	No/Yes		lag_rec
<b>STANDBY CHILLER: Mode</b>	Reset,Off,Local,CCN		stdmode
<b>Run Status</b>	Timeout,Recycle,Startup,Ramping,Running Demand,Override,Shutdown,Abnor- mal,Pumpdown		stdstat
<b>Start/Stop</b>	Stop,Start,Retain		std_s_s
<b>Recovery Start Request</b>	No/Yes		std_rec

#### Notes:

1. Only values with capital letter reference point names are variables available for read operation. Forcing is not supported on this maintenance screen.
2. The MAINT04 screen is available on PSIO Software Version 09 and higher.
3. Δ = delta degrees.



**Table 3 — Protective Safety Limits and Control Settings**

Monitored Parameter	Limit	Applicable Comments
Temperature Sensors Out Of Range	−40 to 245 F (−40 to 118.3 C)	Must be outside range for 2 seconds
Pressure Transducers Out Of Range	0.08 to 0.98 Voltage Ratio	Must be outside range for 2 seconds. Ratio = Input Voltage ÷ Voltage Reference
Compressor Discharge Temperature	>220 F (104.4 C)	Preset, alert setting configurable
Motor Winding Temperature	>220 F (104.4 C)	Preset, alert setting configurable
Bearing Temperature	>185 F (85 C)	Preset, alert setting configurable
Evaporator Refrigerant Temperature	<33 F (for water chilling) (0.6° C)	Preset, configure chilled medium for water (Service1 table)
	<Brine Refrigerant Trippoint (set point adjustable from 0 to 40 F [−18 to 4 C] for brine chilling)	Configure chilled medium for brine (Service1 table). Adjust brine refrigerant trippoint for proper cutout
Transducer Voltage	<4.5 vdc > 5.5 vdc	Preset
Condenser Pressure — Switch — Control	>263 ± 7 psig (1813 ± 48 kPa), reset at 180 ± 10 (1241 ± 69 kPa)	Preset
	>260 psig (1793 kPa) for HCFC-22; 215 psig (1482 kPa) for HFC-134a	Preset
Oil Pressure — Switch — Control	Cutout <11 psid (76 kPad) ± 1.5 psd (10.3 kPad) Cut-in >16.5 psid (114 kPad) ± 4 psid (27.5 kPad)	Preset, no calibration needed
	Cutout <15 psid (103 kPad) Alert <18 psid (124 kPad)	Preset
Line Voltage — High — Low — Single-cycle	>110% for one minute	Preset, based on transformed line voltage to 24 vac rated-input to the Starter Management Module. Also monitored at PSIO power input.
	<90% for one minute or ≤85% for 3 seconds	
	<50% for one cycle	
Compressor Motor Load	>110% for 30 seconds	Preset
	<10% with compressor running	Preset
	>10% with compressor off	Preset



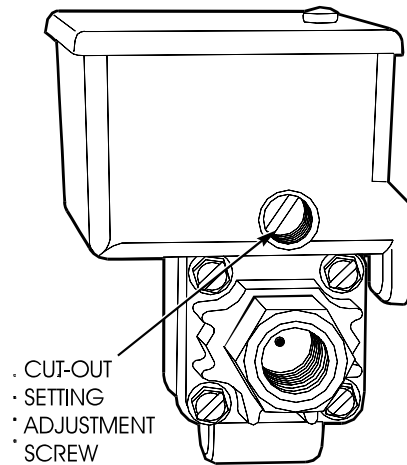
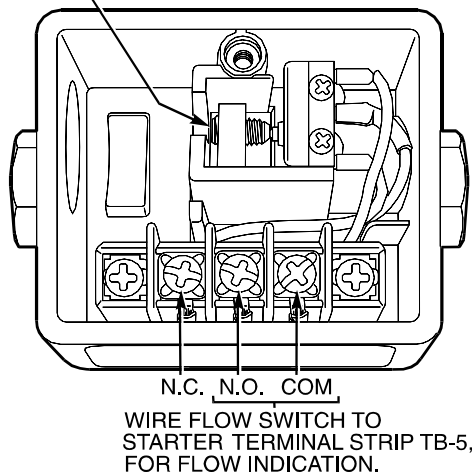
**Table 3 — Protective Safety Limits and Control Settings (Continued)**

Monitored Parameter	Limit	Applicable Comments
<b>Starter Acceleration Time</b> (Determined by inrush current going below 100% compressor motor load)	>45 seconds	For machines with reduced voltage mechanical and solid-state starters
	>10 seconds	For machines with full voltage starters (Configured on Service1 table)
<b>Starter Transition</b>	>75 seconds	Reduced voltage starters only
<b>Condenser Freeze Protection</b>	Energizes condenser pump relay if condenser refrigerant temperature or condenser entering water temperature is below the configured condenser freeze point temperature. Deenergizes when the temperature is 5 F (3 C) above condenser freeze point temperature.	CONDENSER FREEZE POINT configured in Service01 table with a default setting of 34 F (1 C).

**Flow Switches (Field Supplied)**

Operate water pumps with machine off. Manually reduce water flow and observe switch for proper cutout. Safety shutdown occurs when cutout time exceeds 3 seconds.

NO ADJUSTMENTS ARE TO BE MADE ON THIS SETSCREW! (FACTORY ADJUSTED ONLY)



**Table 4 — Capacity Overrides**

Override Capacity Control	First Stage Setpoint				Second Stage Setpoint	Override Termination	
	View/Modify on LID Screen	Default Value		Configurable Range		Value	Value
High Condenser Pressure	Equipment Service1	HCFC-22	HFC-134a	HCFC-22	HFC-134a	>Override Set Point + 4 psid (28 kPad)	<Override Set Point
		>195 psig (1345 kPa)	125 psig (862 kPa)	150 to 245 psig (1034-1689 kPa)	90 to 200 psig (620 to 1379 kPa)		
High Motor Temperature	Equipment Service1	>200 F (93.3 C)		150 to 200 F (66 to 93 C)		>Override Set Point +10° F (6° C)	<Override Set Point
Low Refrigerant Temperature (Refrigerant Override Delta Temperature)	Equipment Service1	<3° F (1.6° C) (Above Trippoint)		2° to 5° F (1° to 3° C)		<Trippoint + Override ΔT -1° F (0.56° C)	>Trippoint + Override ΔT +2° F (1.2° C)
High Compressor Lift (Surge Prevention)	Equipment Service1	HCFC-22	HFC-134a	HCFC-22	HFC-134a	None	Within Lift Limits Plus Surge/ HGBP Deadband Setting
		Min: T1 — 1.5° F (0.8° C) P1 — 75 psid (517 kPad) Max: T2 — 10° F (5.6° C) P2 — 170 psid (1172 kPad)	Min: T1 — 1.5° F (0.8° C) P1 — 50 psid (345 kPad) Max: T2 — 10° F (5.6° C) P2 — 85 psid (586 kPad)	0.5° to 15° F (0.3° to 8.3° C) 50 to 170 psid (345 to 1172 kPad)	0.5° to 15° F (0.3° to 8.3° C) 30 to 170 psid (207 to 1172 kPad)		
Manual Guide Vane Target	Control Algorithm Maint01	Automatic		0 to 100%		None	Release of Manual Control



**Table 4 — Capacity Overrides (Continued)**

Override Capacity Control	First Stage Setpoint			Second Stage Setpoint	Override Termination
	View/Modify on LID Screen	Default Value	Configurable Range	Value	Value
<b>Motor Load — Active Demand Limit</b>	Status01	100%	40 to 100%	≥5% of Set Point	2% Lower Than Set Point



**Table 5A — HCFC-22 Pressure – Temperature (F)**

Temperature (F)	Pressure (psi)		Temperature (F)	Pressure (psi)		Temperature (F)	Pressure (psi)	
	Absolute	Gage		Absolute	Gage		Absolute	Gage
<b>-50</b>	11.67	6.154*	<b>20</b>	57.73	43.03	<b>90</b>	183.09	168.40
<b>-48</b>	12.34	4.829*	<b>22</b>	59.97	45.27	<b>92</b>	188.37	173.67
<b>-46</b>	13.00	3.445*	<b>24</b>	62.27	47.58	<b>94</b>	193.76	179.06
<b>-44</b>	13.71	2.002*	<b>26</b>	64.64	49.95	<b>96</b>	199.26	184.56
<b>-42</b>	14.45	0.498*	<b>28</b>	67.08	52.39	<b>98</b>	204.87	190.18
<b>-40</b>	15.22	0.526	<b>30</b>	69.59	54.90	<b>100</b>	210.60	195.91
<b>-38</b>	16.02	1.328	<b>32</b>	72.17	57.47	<b>102</b>	216.45	201.76
<b>-36</b>	16.86	2.163	<b>34</b>	74.82	60.12	<b>104</b>	222.42	207.72
<b>-34</b>	17.73	3.032	<b>36</b>	77.54	62.84	<b>106</b>	228.50	213.81
<b>-32</b>	18.63	3.937	<b>38</b>	80.34	65.64	<b>108</b>	234.71	220.02
<b>-30</b>	19.57	4.877	<b>40</b>	83.21	68.51	<b>110</b>	241.04	226.35
<b>-28</b>	20.55	5.853	<b>42</b>	86.15	71.46	<b>112</b>	247.50	232.80
<b>-26</b>	21.56	6.868	<b>44</b>	89.18	74.48	<b>114</b>	254.08	239.38
<b>-24</b>	22.62	7.921	<b>46</b>	92.28	77.58	<b>116</b>	260.79	246.10
<b>-22</b>	23.71	9.015	<b>48</b>	95.46	80.77	<b>118</b>	267.63	252.94
<b>-20</b>	24.85	10.15	<b>50</b>	98.73	84.03	<b>120</b>	274.60	259.91
<b>-18</b>	26.02	11.32	<b>52</b>	102.07	87.38	<b>122</b>	281.71	267.01
<b>-16</b>	27.24	12.54	<b>54</b>	105.50	90.81	<b>124</b>	288.95	274.25
<b>-14</b>	28.50	13.81	<b>56</b>	109.02	94.32	<b>126</b>	296.33	281.63
<b>-12</b>	29.81	15.11	<b>58</b>	112.62	97.93	<b>128</b>	303.84	289.14
<b>-10</b>	31.16	16.47	<b>60</b>	116.31	101.62	<b>130</b>	311.50	296.80
<b>-8</b>	32.56	17.87	<b>62</b>	120.09	105.39	<b>132</b>	319.29	304.60
<b>-6</b>	34.01	19.32	<b>64</b>	123.96	109.26	<b>134</b>	327.23	312.54
<b>-4</b>	35.51	20.81	<b>66</b>	127.92	113.22	<b>136</b>	335.32	320.63
<b>-2</b>	37.06	22.36	<b>68</b>	131.97	117.28	<b>138</b>	343.56	328.86
<b>0</b>	38.66	23.96	<b>70</b>	136.12	121.43	<b>140</b>	351.94	337.25
<b>2</b>	40.31	25.61	<b>72</b>	140.37	125.67	<b>142</b>	360.48	345.79
<b>4</b>	42.01	27.32	<b>74</b>	144.71	130.01	<b>144</b>	369.17	354.48
<b>6</b>	43.78	29.08	<b>76</b>	149.15	134.45	<b>146</b>	378.02	363.32
<b>8</b>	45.59	30.90	<b>78</b>	153.69	138.99	<b>148</b>	387.03	372.33
<b>10</b>	47.46	32.77	<b>80</b>	158.33	143.63	<b>150</b>	396.19	381.50
<b>12</b>	49.40	34.70	<b>82</b>	163.07	148.37	<b>152</b>	405.52	390.83
<b>14</b>	51.39	36.69	<b>84</b>	167.92	153.22	<b>154</b>	415.02	400.32
<b>16</b>	53.44	38.74	<b>86</b>	172.87	158.17	<b>156</b>	424.68	409.99
<b>18</b>	55.55	40.86	<b>88</b>	177.93	163.23	<b>158</b>	434.52	419.82
						<b>160</b>	444.53	420.83

\* Inches of mercury below one atmosphere.





**Table 5B — HCFC-22 Pressure – Temperature (C)**

Temperature (C)	Pressure (kPa)		Temperature (C)	Pressure (kPa)		Temperature (C)	Pressure (kPa)	
	Absolute	Gage		Absolute	Gage		Absolute	Gage
<b>-18</b>	264	163	<b>11</b>	701	600	<b>41</b>	1570	1470
<b>-17</b>	274	173	<b>12</b>	723	622	<b>42</b>	1610	1510
<b>-16</b>	284	183	<b>13</b>	744	643	<b>43</b>	1650	1550
<b>-15</b>	296	195	<b>14</b>	766	665	<b>44</b>	1690	1590
			<b>15</b>	789	688	<b>45</b>	1730	1630
<b>-14</b>	307	206	<b>16</b>	812	711	<b>46</b>	1770	1670
<b>-13</b>	318	217	<b>17</b>	836	735	<b>47</b>	1810	1710
<b>-12</b>	330	229	<b>18</b>	860	759	<b>48</b>	1850	1750
<b>-11</b>	342	241	<b>19</b>	885	784	<b>49</b>	1900	1800
<b>-10</b>	354	253	<b>20</b>	910	809	<b>50</b>	1940	1840
<b>-9</b>	367	266	<b>21</b>	936	835	<b>51</b>	1980	1890
<b>-8</b>	380	279	<b>22</b>	962	861	<b>52</b>	2030	1930
<b>-7</b>	393	292	<b>23</b>	989	888	<b>53</b>	2080	1980
<b>-6</b>	407	306	<b>24</b>	1020	919	<b>54</b>	2130	2030
<b>-5</b>	421	320	<b>25</b>	1040	939	<b>55</b>	2170	2070
<b>-4</b>	436	335	<b>26</b>	1070	969	<b>56</b>	2220	2120
<b>-3</b>	451	350	<b>27</b>	1100	1000	<b>57</b>	2270	2170
<b>-2</b>	466	365	<b>28</b>	1130	1030	<b>58</b>	2320	2220
<b>-1</b>	482	381	<b>29</b>	1160	1060	<b>59</b>	2370	2270
<b>0</b>	498	397	<b>30</b>	1190	1090	<b>60</b>	2430	2330
<b>1</b>	514	413	<b>31</b>	1220	1120	<b>61</b>	2480	2380
<b>2</b>	531	430	<b>32</b>	1260	1160	<b>62</b>	2530	2430
<b>3</b>	548	447	<b>33</b>	1290	1190	<b>63</b>	2590	2490
<b>4</b>	566	465	<b>34</b>	1320	1220	<b>64</b>	2640	2540
<b>5</b>	584	483	<b>35</b>	1360	1260	<b>65</b>	2700	2600
<b>6</b>	602	501	<b>36</b>	1390	1290	<b>66</b>	2760	2660
<b>7</b>	621	520	<b>37</b>	1420	1320	<b>67</b>	2820	2720
<b>8</b>	641	540	<b>38</b>	1460	1360	<b>68</b>	2870	2770
<b>9</b>	660	559	<b>39</b>	1500	1400	<b>69</b>	2930	2830
<b>10</b>	681	580	<b>40</b>	1530	1430	<b>70</b>	3000	2900



**Table 5C — HFC-134a Pressure – Temperature (F)**

<b>Temperature, F</b>	<b>Pressure (psig)</b>
0	6.50
2	7.52
4	8.60
6	9.66
8	10.79
10	11.96
12	13.17
14	14.42
16	15.72
18	17.06
20	18.45
22	19.88
24	21.37
26	22.90
28	24.48
30	26.11
32	27.80
34	29.53
36	31.32
38	33.17
40	35.08
42	37.04
44	39.06
46	41.14
48	43.28
50	45.48
52	47.74
54	50.07
56	52.47
58	54.93
60	57.46
62	60.06
64	62.73
66	65.47
68	68.29



**Table 5C — HFC-134a Pressure – Temperature (F) (Continued)**

<b>Temperature, F</b>	<b>Pressure (psig)</b>
70	71.18
72	74.14
74	77.18
76	80.30
78	83.49
80	86.17
82	90.13
84	93.57
86	97.09
88	100.70
90	104.40
92	108.18
94	112.06
96	116.02
98	120.08
100	124.23
102	128.47
104	132.81
106	137.25
108	141.79
110	146.43
112	151.17
114	156.01
116	160.96
118	166.01
120	171.17
122	176.45
124	181.83
126	187.32
128	192.93
130	198.66
132	204.50
134	210.47
136	216.55
138	222.76
140	229.09



**Table 5D — HFC-134a Pressure – Temperature (C)**

<b>Temperature, C</b>	<b>Pressure Gage (kPa)</b>
-18.0	44.8
-16.7	51.9
-15.6	59.3
-14.4	66.6
-13.3	74.4
-12.2	82.5
-11.1	90.8
-10.0	99.4
-8.9	108.0
-7.8	118.0
-6.7	127.0
-5.6	137.0
-4.4	147.0
-3.3	158.0
-2.2	169.0
-1.1	180.0
0.0	192.0
1.1	204.0
2.2	216.0
3.3	229.0
4.4	242.0
5.0	248.0
5.6	255.0
6.1	261.0
6.7	269.0
7.2	276.0
7.8	284.0
8.3	290.0
8.9	298.0
9.4	305.0
10.0	314.0
11.1	329.0
12.2	345.0
13.3	362.0
14.4	379.0



**Table 5D — HFC-134a Pressure – Temperature (C) (Continued)**

<b>Temperature, C</b>	<b>Pressure Gage (kPa)</b>
15.6	396.0
16.7	414.0
17.8	433.0
18.9	451.0
20.0	471.0
21.1	491.0
22.2	511.0
23.3	532.0
24.4	554.0
25.6	576.0
26.7	598.0
27.8	621.0
28.9	645.0
30.0	669.0
31.1	694.0
32.2	720.0
33.3	746.0
34.4	773.0
35.6	800.0
36.7	828.0
37.8	857.0
38.9	886.0
40.0	916.0
41.1	946.0
42.2	978.0
43.3	1010.0
44.4	1042.0
45.6	1076.0
46.7	1110.0
47.8	1145.0
48.9	1180.0
50.0	1217.0
51.1	1254.0
52.2	1292.0
53.3	1330.0
54.4	1370.0
55.6	1410.0
56.7	1451.0
57.8	1493.0
58.9	1536.0
60.0	1580.0



**Table 6 — Potentiometer Adjustment**

<b>Dial</b>	<b>Adjustment Range</b>		<b>Function</b>	<b>Factory Setting</b>
	<b>Minimum (CCW)</b>	<b>Maximum (CW)</b>		
<b>Starting Current</b>	100%	400%	Sets initial starting current level.	100%
<b>Ramp Time (Adjustable Current Ramp)</b>	2 seconds	30 seconds	Sets time during which current ramps from the initial starting level to the maximum possible current limit setting.	15 seconds
<b>Current Limit</b>	100%	400%	Sets maximum starting current.	250%
<b>Pulse Start</b>	0 (Off)	2 seconds	Sets duration of 400% current pulse. Pulse is used to break load free.	OFF
<b>Current Trip</b>	50%	400%	Sets running current trip.	175%
<b>Power Saver</b>	—	—	—	OFF

CCW — Counterclockwise

CW — Clockwise



**Table 7 — Amps Correction Factors for 19XL Motors**

Volt/ Hz	Motor Code							
	CD	CE	CL	CM	CN	CP	CQ	CR
<b>200/60</b>	3	6	3	2	3	2	2	2
<b>208/60</b>	5	8	4	2	4	2	2	2
<b>220/60</b>	2	2	2	3	1	1	1	1
<b>230/60</b>	4	4	3	5	2	2	2	2
<b>240/60</b>	4	4	3	8	2	2	2	2
<b>360/60</b>	4	2	2	2	1	1	1	1
<b>380/60</b>	6	4	4	5	3	2	2	2
<b>400/60</b>	8	4	4	5	3	2	3	4
<b>440/60</b>	2	2	1	1	1	1	3	4
<b>460/60</b>	3	2	2	2	2	2	5	6
<b>480/60</b>	4	3	3	3	3	3	7	8
<b>550/60</b>	3	2	1	2	3	2	2	2
<b>575/60</b>	4	2	2	3	4	3	3	3
<b>600/60</b>	6	4	3	4	6	5	4	4
<b>3300/60</b>	4	1	2	3	3	3	2	2
<b>2400/60</b>	3	3	2	3	2	2	3	3
<b>4160/60</b>	3	3	2	3	2	2	3	3
<b>220/50</b>	2	2	2	3	2	1	1	1
<b>230/50</b>	2	3	2	4	3	2	1	1
<b>240/50</b>	5	4	3	5	3	3	2	2
<b>320/50</b>	2	2	1	1	1	1	3	3
<b>346/50</b>	3	3	3	2	1	2	3	4
<b>360/50</b>	4	4	4	2	2	2	8	8
<b>380/50</b>	3	3	3	2	4	2	2	2
<b>400/50</b>	4	5	4	3	6	4	3	3
<b>415/50</b>	5	6	5	4	7	5	4	4
<b>3000/50</b>	2	3	2	3	1	2	1	2
<b>3300/50</b>	3	3	3	4	2	2	1	2



**Table 8 — Control Test Menu Functions**

Tests To Be Performed	Devices Tested
<p><b>1. Automated Tests*</b></p> <p><b>2. PSIO Thermistors</b></p> <p><b>3. Options Thermistors</b></p> <p><b>4. Transducers</b></p> <p><b>5. Guide Vane Actuator</b></p> <p><b>6. Pumps</b></p>	<p>Operates the second through seventh tests</p> <p>Entering chilled water Leaving chilled water Entering condenser water Leaving condenser water Discharge temperature Bearing temperature Motor winding temperature Oil sump temperature</p> <p>Common chilled water supply sensor Common chilled water return sensor Remote reset sensor Temperature sensor — Spare 1, Spare 2, Spare 3, Spare 4, Spare 5, Spare 6, Spare 7, Spare 8, Spare 9</p> <p>Evaporator pressure Condenser pressure Oil pressure differential Oil pump pressure</p> <p>Open Close</p> <p>All pumps or individual pumps may be activated: Oil pump — Confirm pressure Chilled water pump — Confirm flow Condenser water pump — Confirm flow</p>





**Table 8 — Control Test Menu Functions (Continued)**

Tests To Be Performed	Devices Tested
<b>7. Discrete Outputs</b>	All outputs or individual outputs may be energized: Hot gas bypass relay Oil heater relay Motor cooling relay Tower fan relay Alarm relay
<b>8. Pumpdown/Lockout</b>	When using pumpdown/lockout, observe freeze up precautions when removing charge: Instructs operator as to which valves to close and when Starts chilled water and condenser water pumps and confirms flows Monitors — Evaporator pressure Condenser pressure Evaporator temperature during pumpout procedures Turns pumps off after pumpdown Locks out compressor
<b>9. Terminate Lockout</b>	Starts pumps and monitors flows Instructs operator as to which valves to open and when Monitors — Evaporator pressure Condenser pressure Evaporator temperature during charging process Terminates compressor lockout
<b>10. Refrigerant Type</b>	Sets refrigerant type used: HCFC-22 or HFC-134a. NOTE: Be sure to ATTACH TO LOCAL DEVICE after changing refrigerant type. See <a href="#">Figure 16</a> .

\* During any of the tests that are not automated, an out-of-range reading will have an asterisk (\*) next to the reading and a message will be displayed.



**Table 9 — Refrigerant (HCFC-22 or HFC-134a) Charges**

Cooler Size	19XL Total Refrigerant Charge			
	Design I Machine		Design II Machine	
	lb	kg	lb	kg
40	1420	640	1270	576
41	1490	680	1340	607
42	1550	700	1400	635
43	1600	730	1450	658
50	1850	840	1650	748
51	1900	860	1700	771
52	1980	900	1780	807
53	2050	930	1850	839
55	—	—	2330	1057
56	—	—	2400	1089
57	—	—	2510	1139
58	—	—	2610	1184

**Notes:**

1. The size of the cooler determines refrigerant charge for the entire machine.
2. Design I machines have float chambers.
3. Design II machines have linear floats.



## Legend For Table 10, A - N

1CR_AUX	—	Compressor Start Contact	OILPD	—	Oil Pressure
CA_P	—	Compressor Current	OILT	—	Oil Sump Temperature
CDFL	—	Condenser Water Flow	PIC	—	Product Integrated Control
CHIL_S_S	—	Chiller Start/Stop	PRS_TRIP	—	Pressure Trip Contact
CMPD	—	Discharge Temperature	PSIO	—	Processor Sensor Input/Output Module
CRP	—	Condenser Pressure	RLA	—	Rated Load Amps
ERT	—	Evaporator Refrigerant Temperature	RUN_AUX	—	Compressor Run Contact
EVFL	—	Chilled Water Flow	SPR_PL	—	Spare Protective Limit Input
GV_TRG	—	Target Guide Vane Position	SMM	—	Starter Management Module
LID	—	Local Interface Device	STR_FLT	—	Starter Fault
MTRB	—	Bearing Temperature	TXV	—	Thermostatic Expansion Valve
MTRW	—	Motor Winding Temperature	V_P	—	Line Voltage: Percent
			V_REF	—	Voltage Reference

**Table 10A — Shutdown with On/Off/Reset-Off**

Primary Message	Secondary Message	Probable Cause/Remedy
<b>Manually Stopped — Press</b>	CCN or Local to Start	PIC in OFF mode, press the CCN or local softkey to start unit.
<b>Terminate Pumpdown Mode</b>	To Select CCN or Local	Enter the Control Test table and select Terminate Lockout to unlock compressor.
<b>Shutdown In Progress</b>	Compressor Unloading	Machine unloading before shutdown due to Soft Stop feature.
<b>Shutdown In Progress</b>	Compressor Deenergized	Machine compressor is being commanded to stop. Water pumps are deenergized within one minute.
<b>Ice Build</b>	Operation Complete	Machine shutdown from Ice Build operation.



**Table 10B — Timing Out or Timed Out**

<b>Primary Message</b>	<b>Secondary Message</b>	<b>Probable Cause/Remedy</b>
<b>Ready To Start In XX Min</b>	Unoccupied Mode	Time schedule for PIC is unoccupied. Machines will start only when occupied.
<b>Ready To Start In XX Min</b>	Remote Contacts Open	Remote contacts have stopped machine. Close contacts to start.
<b>Ready To Start In XX Min</b>	Stop Command In Effect	Chiller START/STOP on Status01 manually forced to stop. Release value to start.
<b>Ready To Start In XX Min</b>	Recycle Restart Pending	Machine in recycle mode.
<b>Ready To Start</b>	Unoccupied Mode	Time schedule for PIC is UNOCCUPIED. Machine will start when occupied. Make sure the time and date have been set on the Service menu.
<b>Ready To Start</b>	Remote Contacts Open	Remote contacts have stopped machine. Close contacts to start.
<b>Ready To Start</b>	Stop Command In Effect	Chiller START/STOP on Status01 manually forced to stop. Release value to start.
<b>Ready To Start In XX Min</b>	Remote Contacts Closed	Machine timer counting down unit. Ready for start.
<b>Ready To Start In XX Min</b>	Occupied Mode	Machine timer counting down unit. Ready for start.
<b>Ready To Start</b>	Remote Contacts Closed	Machine timers complete, unit start will commence.
<b>Ready To Start</b>	Occupied Mode	Machine timers complete, unit start will commence.
<b>Startup Inhibited</b>	Loadshed In Effect	CCN loadshed module commanding chiller to stop.
<b>Ready To Start In XX Min</b>	Start Command In Effect	Chiller START/STOP on Status01 has been manually forced to start. Machine will start regardless of time schedule or remote contact status.





**Table 10C — In Recycle Shutdown**

<b>Primary Message</b>	<b>Secondary Message</b>	<b>Probable Cause/Remedy</b>
<b>Recycle Restart Pending</b>	Occupied Mode	Unit in recycle mode, chilled water temperature is not high enough to start.
<b>Recycle Restart Pending</b>	Remote Contact Closed	Unit in recycle mode, chilled water temperature is not high enough to start.
<b>Recycle Restart Pending</b>	Start Command In Effect	Chiller START/STOP on Status01 manually forced to start, chill water temperature is not high enough to start.
<b>Recycle Restart Pending</b>	Ice Build Mode	Machine in ICE BUILD mode. Chilled Water/Brine Temperature is satisfied for Ice Build Setpoint temperature.





**Table 10D — Prestart Alerts: These alerts only delay start-up. When alert is corrected, the start-up will continue. No reset is necessary.**

Primary Message	Secondary Message	Alarm Message/Primary Cause	Additional Cause/Remedy
Prestart Alert	Starts Limit Exceeded	STARTS EXCESSIVE Compressor Starts (8 in 12 hours)	Depress the RESET softkey if additional start is required. Reassess start-up requirements.
Prestart Alert	High Motor Temperature	MTRW VALUE exceeded limit of [LIMIT]*. Check motor temperature.	Check motor cooling line for proper operation. Check for excessive starts within a short time span.
Prestart Alert	High Bearing Temperature	MTRB VALUE exceeded limit of [LIMIT]*. Check thrust bearing temperature.	Check oil heater for proper operation, check for low oil level, partially closed oil supply valves, etc. Check sensor accuracy.
Prestart Alert	High Discharge Temp	CMPD VALUE exceeded limit of [LIMIT]*. Check discharge temperature.	Check sensor accuracy. Allow discharge temperature to cool. Check for excessive starts.
Prestart Alert	Low Refrigerant Temp	ERT VALUE exceeded limit of [LIMIT]*. Check refrigerant temperature.	Check transducer accuracy. Check for low chilled water/brine supply temperature.
Prestart Alert	Low Oil Temperature	OILT VALUE exceeded limit of [LIMIT]*. Check oil temperature.	Check oil heater power, oil heater relay. Check oil level.
Prestart Alert	Low Line Voltage	V_P VALUE exceeded limit of [LIMIT]*. Check voltage supply.	Check voltage supply. Check voltage transformers. Consult power utility if voltage is low. Adjust voltage potentiometer in starter for SMM voltage input.
Prestart Alert	High Line Voltage	V_P VALUE exceeded limit of [LIMIT]*. Check voltage supply.	Check voltage supply. Check voltage transformers. Consult power utility if voltage is low. Adjust voltage potentiometer in starter for SMM voltage input.
Prestart Alert	High Condenser Pressure	CRP VALUE exceeded limit of [LIMIT]*. Check condenser water and transducer.	Check for high condenser water temperature. Check transducer accuracy.

\* [LIMIT] is shown on the LID as temperature, pressure, voltage, etc., predefined or selected by the operator as an override or an alert.





**Table 10E — Normal or Auto.-Restart**

<b>Primary Message</b>	<b>Secondary Message</b>	<b>Probable Cause/Remedy</b>
<b>Startup in Progress</b>	Occupied Mode	Machine starting. Time schedule is occupied.
<b>Startup in Progress</b>	Remote Contact Closed	Machine starting. Remote contacts are closed.
<b>Startup in Progress</b>	Start Command In Effect	Machine starting. Chiller START/STOP on Status01 manually forced to start.
<b>AutoRestart in Progress</b>	Occupied Mode	Machine starting. Time schedule is occupied.
<b>AutoRestart in Progress</b>	Remote Contact Closed	Machine starting. Remote contacts are closed.
<b>AutoRestart in Progress</b>	Start Command In Effect	Machine starting. Chiller START/STOP on Status01 manually forced to start.





**Table 10F — Start-Up Failures: This is an alarm condition. A manual reset is required to clear.**

Primary Message	Secondary Message	Alarm Message/Primary Cause	Additional Cause/Remedy
Failure To Start	Low Oil Pressure	OILPD [VALUE] exceeded limit of [LIMIT]*. Check oil pump system.	Check for closed oil supply valves. Check oil filter. Check for low oil temperature. Check transducer accuracy.
Failure To Start	Oil Press Sensor Fault	OILPD [VALUE] exceeded limit of [LIMIT]*. Check oil pressure sensor.	Check for excessive refrigerant in oil sump. Run oil pump manually for 5 minutes. Check transducer calibration. Check cooler pressure transducer calibration. Check wiring. Replace transducer if necessary.
Failure To Start	Low Chilled Water Flow	EVFL Evap Flow Fault: Check water pump/flow switch.	Check wiring to flow switch. Check through Control Test for proper switch operation.
Failure To Start	Low Condenser Water Flow	CDFL Cond. Flow Fault: Check water pump/flow switch.	Check wiring to flow switch. Check through Control Test for proper switch operation.
Failure To Start	Starter Fault	STR_FLT Starter Fault: Check Starter for Fault Source.	A starter protective device has faulted. Check starter for ground fault, voltage trip, temperature trip, etc.
Failure To Start	Starter Overload Trip	STR_FLT Starter Overload Trip: Check amps calibration/reset overload.	Reset overloads before restart.
Failure To Start	Line Voltage Dropout	V_P Single-Cycle Dropout Detected: Check voltage supply.	Check voltage supply. Check transformers for supply. Check with utility if voltage supply is erratic. Monitor must be installed to confirm consistent, single-cycle dropouts. Check low oil pressure switch.
Failure To Start	High Condenser Pressure	High Condenser Pressure [LIMIT]: Check switch 2C aux, and water temperature/flow.	Check for proper design condenser flow and temperature. Check condenser approach. Check 2C auxiliary contacts on oil sump starter. Check high pressure switch.
Failure To Start	Excess Acceleration Time	CA_P Excess Acceleration: Check guide vane closure at start-up.	Check that guide vanes are closed at start-up. Check starter for proper operation. Reduce unit pressure if possible.







**Table 10F — Start-Up Failures: This is an alarm condition. A manual reset is required to clear. (Continued)**

Primary Message	Secondary Message	Alarm Message/Primary Cause	Additional Cause/Remedy
<b>Failure To Start</b>	Starter Transition Fault	RUN_AUX Starter Transition Fault: Check 1CR/1M/Interlock mechanism.	Check starter for proper operation. Run contact failed to close.
<b>Failure To Start</b>	1CR AUX Contact Fault	1CR_AUX Starter Contact Fault: Check 1CR/1M aux. contacts.	Check starter for proper operation. Start contact failed to close.
<b>Failure To Start</b>	Motor Amps Not Sensed	CA_P Motor Amps Not Sensed: Check motor load signal.	Check for proper motor amps signal to SMM. Check wiring from SMM to current transformer. Check main motor circuit breaker for trip.
<b>Failure To Start</b>	Check Refrigerant Type	Current Refrigerant Properties Abnormal — Check Selection of refrigerant type	Pressures at transducers indicate another refrigerant type in Control Test. Make sure to access the ATTACH TO NETWORK DEVICE table after changing refrigerant type.
<b>Failure To Start</b>	Low Oil Pressure	Low Oil Pressure [LIMIT]: Check oil pressure switch/pump and 2C aux.	The oil pressure differential switch is open when the compressor tried to START. Check the switch for proper operation. Also, check the oil pump interlock (2C aux) in the power panel and the high condenser pressure switch.

\* [LIMIT] is shown on the LID as the temperature, pressure, voltage, etc., set point predefined or selected by the operator as an override, alert, or alarm condition. [VALUE] is the actual pressure, temperature, voltage, etc., at which the control tripped.





**Table 10G — Compressor Jumpstart and Refrigerant Protection**

<b>Primary Message</b>	<b>Secondary Message</b>	<b>Alarm Message/Primary Cause</b>	<b>Additional Cause/Remedy</b>
<b>Unauthorized Operation</b>	Unit Should Be Stopped	CA_P Emergency: Compressor running without control authorization.	Compressor is running with more than 10% RLA and control is trying to shut it down. Throw power off to compressor if unable to stop. Determine cause before repowering.
<b>Potential Freeze-up</b>	Evap Press/Temp Too Low	ERT Emergency: Freeze-up prevention.	Determine cause. If pumping refrigerant out of machine, stop operation and go over pumpout procedures.
<b>Failure To Stop</b>	Disconnect Power	RUN_AUX Emergency: DISCONNECT POWER.	Starter and run and start contacts are energized while control tried to shut down. Disconnect power to starter.
<b>Loss Of Communciation</b>	With Starter	Loss of Communication with Starter: Check machine.	Check wiring from PSIO to SMM. Check SMM module troubleshooting procedures.
<b>Starter Contact Fault</b>	Abnormal 1CR or Run Aux	1CR_AUX Starter Contact Fault: Check 1CR/1M aux. contacts.	Starter run and start contacts energized while machine was off. Disconnect power.
<b>Potential Freeze Up</b>	Cond Press/Temp Too Low	CRT [VALUE] exceeded limit of [LIMIT]* Emergency: Freeze-up prevention.	The condenser pressure transducer is reading a pressure that could freeze the water in the condenser tubes. Check for condenser refrigerant leaks, bad transducers, or transferred refrigerant. Place the unit in Pumpdown mode to eliminate ALARM if vessel is evacuated.

\* [LIMIT] is shown on the LID as the temperature, pressure, voltage, etc., set point predefined or selected by the operator as an override, alert, or alarm condition. [VALUE] is the actual pressure, temperature, voltage, etc., at which the control tripped.



**Table 10H — Normal Run with Reset, Temperature, or Demand**

Primary Message	Secondary Message	Probable Cause/Remedy
Running — Reset Active	4-20MA Signal	Reset program active based upon Config table setup.
Running — Reset Active	Remote Sensor Control	
Running — Reset Active	CHW Temp Difference	
Running — Temp Control	Leaving Chilled Water	Default method of temperature control.
Running — Temp Control	Entering Chilled Water	ECW control activated on Config table.
Running — Temp Control	Temperature Ramp Loading	Ramp loading in effect. Use Service1 table to modify.
Running — Demand Limited	By Demand Ramp Loading	Ramp loading in effect. Use Service1 table to modify.
Running — Demand Limited	By Local Demand Setpoint	Demand limit setpoint is < actual demand.
Running — Demand Limited	By 4-20MA Signal	Demand limit is active based on Config table setup.
Running — Demand Limited	By CCN Signal	
Running — Demand Limited	By LoadShed/Redline	
Running — Temp Control	Hot Gas Bypass	Hot Gas Bypass is energized. See <a href="#">Surge Prevention</a> in the Control section.
Running — Demand Limited	By Local Signal	Active demand limit manually overridden or Status01 table.
Running — Temp Control	Ice Build Mode	Machine is running under Ice Build temperature control.





**Table 10I — Normal Run Overrides Active (Alerts)**

Primary Message	Secondary Message	Alarm Message/Primary Cause	Additional Cause/Remedy
Run Capacity Limited	High Condenser Pressure	CRP [VALUE]* exceeded limit of [LIMIT]*. Condenser pressure override.	See Capacity Overrides, <a href="#">Table 4</a> . Correct operating condition, modify setpoint, or release override.
Run Capacity Limited	High Motor Temperature	MTRW [VALUE]* exceeded limit of [LIMIT]*. Motor temperature override.	
Run Capacity Limited	Low Evap Refrig Temp	ERT [VALUE]* exceeded limit of [LIMIT]*. Check refrigerant charge level.	
Run Capacity Limited	High Compressor Lift	Surge Prevention Override; lift too high for compressor.	
Run Capacity Limited	Manual Guide Vane Target	GV_TRG Run Capacity Limited: Manual guide vane target.	

\* [LIMIT] is shown on the LID as the temperature, pressure, voltage, etc., set point predefined or selected by the operator as an override, alert, or alarm condition. [VALUE] is the actual temperature, pressure, voltage, etc., at which the control tripped.





**Table 10J — Out-of-Range Sensor Failures**

<b>Primary Message</b>	<b>Secondary Message</b>	<b>Alarm Message/Primary Cause</b>	<b>Additional Cause/Remedy</b>
<b>Sensor Fault</b>	Leaving CHW Temperature	Sensor Fault: Check leaving CHW sensor.	See sensor test procedure and check sensors for proper operation and wiring.
<b>Sensor Fault</b>	Entering CHW Temperature	Sensor Fault: Check entering CHW sensor.	
<b>Sensor Fault</b>	Condenser Pressure	Sensor Fault: Check condenser pressure transducer.	
<b>Sensor Fault</b>	Evaporator Pressure	Sensor Fault: Check evaporator pressure transducer.	
<b>Sensor Fault</b>	Bearing Temperature	Sensor Fault: Check bearing temperature sensor.	
<b>Sensor Fault</b>	Motor Winding Temp	Sensor Fault: Check motor temperature sensor.	
<b>Sensor Fault</b>	Discharge Temperature	Sensor Fault: Check discharge temperature sensor.	
<b>Sensor Fault</b>	Oil Sump Temperature	Sensor Fault: Check oil sump temperature sensor.	
<b>Sensor Fault</b>	Oil Pressure Transducer	Sensor Fault: Check oil pressure transducer.	





Table 10K — Machine Protect Limit Faults

**WARNING**



**WARNING**

Excessive numbers of the same fault can lead to severe machine damage.  
Seek service expertise.

Primary Message	Secondary Message	Alarm Message/ Primary Cause	Additional Cause/Remedy
Protective Limit	High Discharge Temp	CMPD [VALUE] exceeded limit of [LIMIT]*. Check discharge temperature.	Check discharge temperature immediately. Check sensor for accuracy; check for proper condenser flow and temperature; check oil reservoir temperature. Check condenser for fouled tubes or air in machine. Check for proper guide vane actuator operation.
Protective Limit	Low Refrigerant Temp	ERT [VALUE] exceed limit of [LIMIT]*. Check evap pump and flow switch.	Check for proper amount of refrigerant charge; check for proper water flow and temperatures. Check for proper guide vane actuator operation.
Protective Limit	High Motor Temperature	MTRW [VALUE] exceeded limit of [LIMIT]*. Check motor cooling and solenoid.	Check motor temperature immediately. Check sensor for accuracy. Check for proper condenser flow and temperature. Check motor cooling system for restrictions. Check motor cooling solenoid for proper operation. Check refrigerant filter.
Protective Limit	High Bearing Temperature	MTRB [VALUE] exceeded limit of [LIMIT]*. Check oil cooling control.	Check for throttled oil supply isolation valves. Valves should be wide open. Check oil cooler thermal expansion valve. Check sensor accuracy. Check journal and thrust bearings. Check refrigerant filter. Check for excessive oil sump level.
Protective Limit	Low Oil Pressure	OILPD [VALUE] exceeded limit of [LIMIT]*. Check oil pump and transducer.	Check power to oil pump and oil level. Check for dirty filters or oil foaming at start-up. Check for thermal overload cut-out. Reduce ramp load rate if foaming noted. <b>Note:</b> This alarm is not related to pressure switch problems.
Protective Limit	No Motor Current	CA_P Loss of Motor Current: Check sensor.	Check wiring: Check torque setting on solid state starter. Check for main circuit breaker trip. Check power supply to PSIO module.





**Table 10K — Machine Protect Limit Faults (Continued)**

**WARNING**



**WARNING**

**Excessive numbers of the same fault can lead to severe machine damage.  
Seek service expertise.**

Primary Message	Secondary Message	Alarm Message/ Primary Cause	Additional Cause/Remedy
Protective Limit	Power Loss	V_P Power Loss: Check voltage supply.	Check 24-vdc input sensor on the SMM; adjust potentiometer if necessary. Check transformers to SMM. Check power to PSIO module. Check distribution bus. Consult power company.
Protective Limit	Low Line Voltage	V_P [VALUE] exceeded limit of [LIMIT]*. Check voltage supply.	
Protective Limit	High Line Voltage	V_P [VALUE] exceeded limit of [LIMIT]*. Check voltage supply.	
Protective Limit	Low Chilled Water Flow	EVFL Flow Fault: Check evap pump/flow switch.	Perform pumps Control Test and verify proper switch operation. Check all water valves and pump operation.
Protective Limit	Low Condenser Water Flow	CDFL Flow Fault: Check cond pump/flow switch.	
Protective Limit	High Condenser Pressure	High Cond Pressure [OPEN]: Check switch, 2C aux., and water temp/flow.	Check the high-pressure switch. Check for proper condenser pressures and condenser waterflow. Check for fouled tubes. Check the 2C aux. contact and the oil pressure switch in the power panel. This alarm is not caused by the transducer.
Protective Limit	High Condenser Pressure	High Cond Pressure [VALUE]: Check switch, water flow, and transducer.	Check water flow in condenser. Check for fouled tubes. Transducer should be checked for accuracy. This alarm is not caused by the high pressure switch.
Protective Limit	1CR Aux Contact Fault	CR_AUX Starter Contact Fault: Check 1CR/1M aux contacts.	1CR auxiliary contact opened while machine was running. Check starter for proper operation.
Protective Limit	Run Aux Contact Fault	RUN_AUX Starter Contact Fault: Check 1CR/1M aux contacts.	Run auxiliary contact opened while machine was running. Check starter for proper operation.





**Table 10K — Machine Protect Limit Faults (Continued)**

**WARNING**



**WARNING**

**Excessive numbers of the same fault can lead to severe machine damage.  
Seek service expertise.**

Primary Message	Secondary Message	Alarm Message/ Primary Cause	Additional Cause/Remedy
<b>Protective Limit</b>	CCN Override Stop	CHIL_S_S CCN Override Stop while in LOCAL run mode.	CCN has signaled machine to stop. Reset and restart when ready. If the signal was sent by the LID, release the Stop signal on STATUS01 table.
<b>Protective Limit</b>	Spare Safety Device	SRP_PL Spare Safety Fault: Check contacts.	Spare safety input has tripped or factory-installed jumper not present.
<b>Protective Limit</b>	Excessive Motor Amps	CA_P [VALUE] exceeded limit of [LIMIT]*. High Amps; Check guide vane drive.	Check motor current for proper calibration. Check guide vane drive and actuator for proper operation.
<b>Protective Limit</b>	Excessive Compr Surge	Compressor Surge: Check condenser water temp and flow.	Check condenser flow and temperatures. Check configuration of surge protection.
<b>Protective Limit</b>	Starter Fault	STR_FLT Starter Fault: Check starter for fault source.	Check starter for possible ground fault, reverse rotation, voltage trip, etc.
<b>Protective Limit</b>	Starter Overload Trip	STR_FLT Starter Overload Trip: Check amps calibration/reset overload.	Reset overloads and reset alarm. Check motor current calibration or overload calibration (do not field-calibrate overloads).
<b>Protective Limit</b>	Transducer Voltage Fault	V_REF [VALUE] exceeded limit of [LIMIT]*. Check transducer power supply.	Check transformer power (5 vdc) supply to transducers. Power must be 4.5 to 5.5 vdc.
<b>Protective Limit</b>	Low Oil Pressure	Low Oil Pressure [OPEN]: Check oil pressure switch/pump and 2C aux.	Check the oil pressure switch for proper operation. Check oil pump for proper pressure. Check for excessive refrigerant in oil system.

\* [LIMIT] is shown on the LID as the temperature, pressure, voltage, etc., set point predefined or selected by the operator as an override, alert, or alarm condition. [VALUE] is the actual temperature, pressure, voltage, etc., at which the control tripped.





**Table 10L — Machine Alerts**

Primary Message	Secondary Message	Alarm Message/ Primary Cause	Additional Cause/Remedy
<b>Recycle Alert</b>	High Amps at Shut-down	High Amps at Recycle: Check guide vane drive.	Check that guide vanes are closing. Check motor amps correction calibration is correct. Check actuator for proper operation.
<b>Sensor Fault Alert</b>	Leaving Cond Water Temp	Sensor Fault: Check leaving condenser water sensor.	Check sensor. See sensor test procedure.
<b>Sensor Fault Alert</b>	Entering Cond Water Temp	Sensor Fault: Check entering condenser water sensor.	
<b>Low Oil Pressure Alert</b>	Check Oil Filter	Low Oil Pressure Alert: Check oil.	Check oil filter. Check for improper oil level or temperature.
<b>AutoRestart Pending</b>	Power Loss	V_P Power Loss: Check voltage supply.	Check power supply if there are excessive compressor starts occurring.
<b>AutoRestart Pending</b>	Low Line Voltage	V_P [VALUE] exceeded limit of [LIMIT*]. Check voltage supply.	
<b>AutoRestart Pending</b>	High Line Voltage	V_P [VALUE] exceeded limit of [LIMIT*]. Check voltage supply.	
<b>Sensor Alert</b>	High Discharge Temp	CMPD [VALUE] exceeded limit of [LIMIT*]. Check discharge temperature.	Discharge temperature exceeded the alert threshold. Check entering condenser water temperature.
<b>Sensor Alert</b>	High Bearing Temperature	MTRB [VALUE] exceeded limit of [LIMIT*]. Check thrust bearing temperature.	Thrust bearing temperature exceeded the alert threshold. Check for closed valves, improper oil level or temperatures.
<b>Condenser Pressure Alert</b>	Pump Relay Energized	CRP High Condenser Pressure [LIMIT*]. Pump energized to reduce pressure.	Check ambient conditions. Check condenser pressure for accuracy.
<b>Recycle Alert</b>	Excessive Recycle Starts	Excessive recycle starts.	The machine load is too small to keep the machine on line and there have been more than 5 restarts in 4 hours. Increase machine load, adjust hot gas bypass, increase RECYCLE RESTART DELTA T.

\* [LIMIT] is shown on the LID as the temperature, pressure, voltage, etc., set point predefined or selected by the operator as an override, alert, or alarm condition. [VALUE] is the actual temperature, pressure, voltage, etc., at which the control tripped.





**Table 10M — Spare Sensor Alert Messages**

Primary Message	Secondary Message	Alarm Message/Primary Cause	Additional Cause/Remedy
<b>Spare Sensor Alert</b>	Common CHWS Sensor	Sensor Fault: Check common CHWS sensor.	Check alert temperature set points on Equipment Service, SERVICE2 LID table. Check sensor for accuracy if reading is not accurate.
<b>Spare Sensor Alert</b>	Common CHWR Sensor	Sensor Fault: Check common CHWR sensor.	
<b>Spare Sensor Alert</b>	Remote Reset Sensor	Sensor Fault: Check remote reset temperature sensor.	
<b>Spare Sensor Alert</b>	Temp Sensor — Spare 1	Sensor Fault: Check temperature sensor — Spare 1.	
<b>Spare Sensor Alert</b>	Temp Sensor — Spare 2	Sensor Fault: Check temperature sensor — Spare 2.	
<b>Spare Sensor Alert</b>	Temp Sensor — Spare 3	Sensor Fault: Check temperature sensor — Spare 3.	
<b>Spare Sensor Alert</b>	Temp Sensor — Spare 4	Sensor Fault: Check temperature sensor — Spare 4.	
<b>Spare Sensor Alert</b>	Temp Sensor — Spare 5	Sensor Fault: Check temperature sensor — Spare 5.	
<b>Spare Sensor Alert</b>	Temp Sensor — Spare 6	Sensor Fault: Check temperature sensor — Spare 6.	
<b>Spare Sensor Alert</b>	Temp Sensor — Spare 7	Sensor Fault: Check temperature sensor — Spare 7.	
<b>Spare Sensor Alert</b>	Temp Sensor — Spare 8	Sensor Fault: Check temperature sensor — Spare 8.	
<b>Spare Sensor Alert</b>	Temp Sensor — Spare 9	Sensor Fault: Check temperature sensor — Spare 9.	





**Table 10N — Other Problems/Malfunctions**

<b>Description/ Malfunction</b>	<b>Probable Cause/Remedy</b>
<b>Chilled Water/Brine Temperature Too High (Machine Running)</b>	<p>Chilled water set point set too high. Access set point on LID and verify.</p> <p>Capacity override or excessive cooling load (machine at design capacity). Check LID status messages. Check for outside air infiltration into conditioned space.</p> <p>Condenser temperature too high. Check for proper flow, examine cooling tower operation, check for air or water leaks, check for fouled tubes.</p> <p>Refrigerant level low. Check for leaks, add refrigerant, and trim charge.</p> <p>Liquid bypass in waterbox. Examine division plates and gaskets for leaks.</p> <p>Guide vanes fail to open. Use Control Test to check operation.</p> <p>Chilled water control point too high. Access control algorithm status and check chilled water control operation.</p> <p>Guide vanes fail to open fully. Be sure that the guide vane target is released.</p> <p>Check guide vane linkage. Check limit switch in actuator. Check that sensor is in the proper terminals.</p>
<b>Chilled Water/Brine Temperature Too Low (Machine Running)</b>	<p>Chilled water set point set too low. Access set point on LID and verify.</p> <p>Chilled water control point too low. Access control algorithm status and check chilled water control for proper resets.</p> <p>High discharge temperature keeps guide vanes open.</p> <p>Guide vanes fail to close. Be sure that guide vane target is released. Check chilled water sensor accuracy. Check guide vane linkage. Check actuator operation.</p>
<b>Chilled Water Temperature Fluctuates. Vanes Hunt</b>	<p>Deadband too narrow. Configure LID for a larger deadband.</p> <p>Proportional bands too narrow. Either INC or DEC proportional bands should be increased.</p> <p>Loose guide vane drive. Adjust chain drive.</p> <p>Defective vane actuator. Check through Control Test.</p> <p>Defective temperature sensor. Check sensor accuracy.</p>
<b>Low Oil Sump Temperature While Running (Less than 100 F [38 C])</b>	<p>Check for proper oil level (not enough oil). Check for proper refrigerant level (too much refrigerant).</p>
<b>At Power Up, Default Screen Does Not Appear, "Tables Loading" Message Continually Appears</b>	<p>Check for proper communications wiring on PSIO module. Check that the COMM1 communications wires from the LID are terminated to the COMM1 PSIO connection.</p>





**Table 10N — Other Problems/Malfunctions (Continued)**

<b>Description/ Malfunction</b>	<b>Probable Cause/Remedy</b>
<b>SMM Communications Failure</b>	Check that PSIO communication plugs are connected correctly. Check SMM communication plug. Check for proper SMM power supply. See <a href="#">Control Modules</a> section.
<b>High Oil Temperature While Running</b>	Check for proper oil level (too much oil). Check that TXV valve is operating properly.
<b>Blank LID Screen</b>	Increase contrast potentiometer. See <a href="#">Figure 42</a> . Check red LED on LID for proper operation, (power supply). If LED is blinking, but green LED's are not, replace LID module, (memory failure).
<b>“Communications Failure” Highlighted Message At Bottom of LID Screen</b>	LID is not properly addressed to the PSIO. Make sure that “Attach to Network Device,” “Local Device” is set to read the PSIO address. Check LED's on PSIO. Is red LED operating properly? Are green LED's blinking? See control module troubleshooting section.
<b>Controls Test Disabled</b>	Press the “Stop” pushbutton. The PIC must be in the OFF mode for the controls test to operate. Clear all alarms. Check line voltage percent on Status01 screen. The percent must be within 90% to 110%. Check voltage input to SMM, calibrate starter voltage potentiometer for accuracy.
<b>Vanes Will Not Open In Control Test</b>	Low pressure alarm is active. Put machine into pumpdown mode or equalize pressure. Check guide vane actuator wiring.
<b>Oil Pump Does Not Run</b>	Check oil pump voltage supply. Cooler vessel pressure under vacuum. Pressurize vessel. Check temperature overload cutout switch.



**Table 11A — Thermistor Temperature (F) vs Resistance/Voltage Drop**

Temperature (F)	Voltage Drop (V)	Resistance (Ohms)	Temperature (F)	Voltage Drop (V)	Resistance (Ohms)	Temperature (F)	Voltage Drop (V)	Resistance (Ohms)
-25.0	4.821	98,010	23.0	4.278	21,153	71	3.093	5,781
-24.0	4.818	94,707	24.0	4.258	20,547	72	3.064	5,637
-23.0	4.814	91,522	25.0	4.241	19,960	73	3.034	5,497
-22.0	4.806	88,449	26.0	4.223	19,393	74	3.005	5,361
-21.0	4.800	85,486	27.0	4.202	18,843	75	2.977	5,229
-20.0	4.793	82,627	28.0	4.184	18,311	76	2.947	5,101
-19.0	4.786	79,871	29.0	4.165	17,796	77	2.917	4,976
-18.0	4.779	77,212	30.0	4.145	17,297	78	2.884	4,855
-17.0	4.772	74,648	31.0	4.125	16,814	79	2.857	4,737
-16.0	4.764	72,175	32.0	4.103	16,346	80	2.827	4,622
-15.0	4.757	69,790	33.0	4.082	15,892	81	2.797	4,511
-14.0	4.749	67,490	34.0	4.059	15,453	82	2.766	4,403
-13.0	4.740	65,272	35.0	4.037	15,027	83	2.738	4,298
-12.0	4.734	63,133	36.0	4.017	14,614	84	2.718	4,196
-11.0	4.724	61,070	37.0	3.994	14,214	85	2.679	4,096
-10.0	4.715	59,081	38.0	3.968	13,826	86	2.650	4,000
-9.0	4.705	57,162	39.0	3.948	13,449	87	2.622	3,906
-8.0	4.696	55,311	40.0	3.927	13,084	88	2.593	3,814
-7.0	4.688	53,526	41.0	3.902	12,730	89	2.563	3,726
-6.0	4.676	51,804	42.0	3.878	12,387	90	2.533	3,640
-5.0	4.666	50,143	43.0	3.854	12,053	91	2.505	3,556
-4.0	4.657	48,541	44.0	3.828	11,730	92	2.476	3,474
-3.0	4.648	46,996	45.0	3.805	11,416	93	2.447	3,395
-2.0	4.636	45,505	46.0	3.781	11,112	94	2.417	3,318
-1.0	4.624	44,066	47.0	3.757	10,816	95	2.388	3,243
0.0	4.613	42,679	48.0	3.729	10,529	96	2.360	3,170
1.0	4.602	41,339	49.0	3.705	10,250	97	2.332	3,099
2.0	4.592	40,047	50.0	3.679	9,979	98	2.305	3,031
3.0	4.579	38,800	51.0	3.653	9,717	99	2.277	2,964
4.0	4.567	37,596	52.0	3.627	9,461	100	2.251	2,898
5.0	4.554	36,435	53.0	3.600	9,213	101	2.217	2,835
6.0	4.540	35,313	54.0	3.575	8,973	102	2.189	2,773
7.0	4.527	34,231	55.0	3.547	8,739	103	2.162	2,713
8.0	4.514	33,185	56.0	3.520	8,511	104	2.136	2,655
9.0	4.501	32,176	57.0	3.493	8,291	105	2.107	2,597
10.0	4.487	31,202	58.0	3.464	8,076	106	2.080	2,542
11.0	4.472	30,260	59.0	3.437	7,868	107	2.053	2,488
12.0	4.457	29,351	60.0	3.409	7,665	108	2.028	2,436
13.0	4.442	28,473	61.0	3.382	7,468	109	2.001	2,385
14.0	4.427	27,624	62.0	3.353	7,277	110	1.973	2,335
15.0	4.413	26,804	63.0	3.323	7,091	111	1.946	2,286
16.0	4.397	26,011	64.0	3.295	6,911	112	1.919	2,239
17.0	4.381	25,245	65.0	3.267	6,735	113	1.897	2,192
18.0	4.366	24,505	66.0	3.238	6,564	114	1.870	2,147
19.0	4.348	23,789	67.0	3.210	6,399	115	1.846	2,103
20.0	4.330	23,096	68.0	3.181	6,238			
21.0	4.313	22,427	69.0	3.152	6,081			
22.0	4.295	21,779	70.0	3.123	5,929			



**Table 11A — Thermistor Temperature (F) vs Resistance/Voltage Drop (Continued)**

Temperature (F)	Voltage Drop (V)	Resistance (Ohms)	Temperature (F)	Voltage Drop (V)	Resistance (Ohms)	Temperature (F)	Voltage Drop (V)	Resistance (Ohms)
116	1.822	2,060	160	0.945	832	204	0.510	405
117	1.792	2,018	161	0.929	815	205	0.505	401
118	1.771	1,977	162	0.914	798	206	0.499	396
119	1.748	1,937	163	0.898	782	207	0.494	391
120	1.724	1,898	164	0.883	765	208	0.488	386
121	1.702	1,860	165	0.868	750	209	0.483	382
122	1.676	1,822	166	0.853	734	210	0.477	377
123	1.653	1,786	167	0.838	719	211	0.471	372
124	1.630	1,750	168	0.824	705	212	0.465	367
125	1.607	1,715	169	0.810	690	213	0.459	361
126	1.585	1,680	170	0.797	677	214	0.453	356
127	1.562	1,647	171	0.783	663	215	0.446	350
128	1.538	1,614	172	0.770	650	216	0.439	344
129	1.517	1,582	173	0.758	638	217	0.432	338
130	1.496	1,550	174	0.745	626	218	0.425	332
131	1.474	1,519	175	0.734	614	219	0.417	325
132	1.453	1,489	176	0.722	602	220	0.409	318
133	1.431	1,459	177	0.710	591	221	0.401	311
134	1.408	1,430	178	0.700	581	222	0.393	304
135	1.389	1,401	179	0.689	570	223	0.384	297
136	1.369	1,373	180	0.678	561	224	0.375	289
137	1.348	1,345	181	0.668	551	225	0.366	282
138	1.327	1,318	182	0.659	542			
139	1.308	1,291	183	0.649	533			
140	1.291	1,265	184	0.640	524			
141	1.289	1,240	185	0.632	516			
142	1.269	1,214	186	0.623	508			
143	1.250	1,190	187	0.615	501			
144	1.230	1,165	188	0.607	494			
145	1.211	1,141	189	0.600	487			
146	1.192	1,118	190	0.592	480			
147	1.173	1,095	191	0.585	473			
148	1.155	1,072	192	0.579	467			
149	1.136	1,050	193	0.572	461			
150	1.118	1,029	194	0.566	456			
151	1.100	1,007	195	0.560	450			
152	1.082	986	196	0.554	445			
153	1.064	965	197	0.548	439			
154	1.047	945	198	0.542	434			
155	1.029	925	199	0.537	429			
156	1.012	906	200	0.531	424			
157	0.995	887	201	0.526	419			
158	0.978	868	202	0.520	415			
159	0.962	850	203	0.515	410			



**Table 11B — Thermistor Temperature (C) vs Resistance/Voltage Drop**

Temperature (C)	Voltage Drop (V)	Resistance (Ohms)	Temperature (C)	Voltage Drop (V)	Resistance (Ohms)
-40	4.896	168 230	6	3.860	12 085
-39	4.889	157 440	7	3.816	11 506
-38	4.882	147 410	8	3.771	10 959
-37	4.874	138 090	9	3.726	10 441
-36	4.866	129 410	10	3.680	9 949
-35	4.857	121 330	11	3.633	9 485
-34	4.848	113 810	12	3.585	9 044
-33	4.838	106 880	13	3.537	8 627
-32	4.828	100 260	14	3.487	8 231
-31	4.817	94 165	15	3.438	7 855
-30	4.806	88 480	16	3.387	7 499
-29	4.794	83 170	17	3.337	7 161
-28	4.782	78 125	18	3.285	6 840
-27	4.769	73 580	19	3.234	6 536
-26	4.755	69 250	20	3.181	6 246
-25	4.740	65 205	21	3.129	5 971
-24	4.725	61 420	22	3.076	5 710
-23	4.710	57 875	23	3.023	5 461
-22	4.693	54 555	24	2.970	5 225
-21	4.676	51 450	25	2.917	5 000
-20	4.657	48 536	26	2.864	4 786
-19	4.639	45 807	27	2.810	4 583
-18	4.619	43 247	28	2.757	4 389
-17	4.598	40 845	29	2.704	4 204
-16	4.577	38 592	30	2.651	4 028
-15	4.554	38 476	31	2.598	3 861
-14	4.531	34 489	32	2.545	3 701
-13	4.507	32 621	33	2.493	3 549
-12	4.482	30 866	34	2.441	3 404
-11	4.456	29 216	35	2.389	3 266
-10	4.428	27 633	36	2.337	3 134
-9	4.400	26 202	37	2.286	3 008
-8	4.371	24 827	38	2.236	2 888
-7	4.341	23 532	39	2.186	2 773
-6	4.310	22 313	40	2.137	2 663
-5	4.278	21 163	41	2.087	2 559
-4	4.245	20 079	42	2.039	2 459
-3	4.211	19 058	43	1.991	2 363
-2	4.176	18 094	44	1.944	2 272
-1	4.140	17 184	45	1.898	2 184
0	4.103	16 325	46	1.852	2 101
1	4.065	15 515	47	1.807	2 021
2	4.026	14 749	48	1.763	1 944
3	3.986	14 026	49	1.719	1 871
4	3.945	13 342	50	1.677	1 801
5	3.903	12 696	51	1.635	1 734



**Table 11B — Thermistor Temperature (C) vs Resistance/Voltage Drop (Continued)**

Temperature (C)	Voltage Drop (V)	Resistance (Ohms)	Temperature (C)	Voltage Drop (V)	Resistance (Ohms)
52	1.594	1 670	84	0.648	531
53	1.553	1 609	85	0.632	516
54	1.513	1 550	86	0.617	502
55	1.474	1 493	87	0.603	489
56	1.436	1 439	88	0.590	477
57	1.399	1 387	89	0.577	466
58	1.363	1 337	90	0.566	456
59	1.327	1 290	91	0.555	446
60	1.291	1 244	92	0.545	436
61	1.258	1 200	93	0.535	427
62	1.225	1 158	94	0.525	419
63	1.192	1 118	95	0.515	410
64	1.160	1 079	96	0.506	402
65	1.129	1 041	97	0.496	393
66	1.099	1 006	98	0.486	385
67	1.069	971	99	0.476	376
68	1.040	938	100	0.466	367
69	1.012	906	101	0.454	357
70	0.984	876	102	0.442	346
71	0.949	836	103	0.429	335
72	0.920	805	104	0.416	324
73	0.892	775	105	0.401	312
74	0.865	747	106	0.386	299
75	0.838	719	107	0.370	285
76	0.813	693			
77	0.789	669			
78	0.765	645			
79	0.743	623			
80	0.722	602			
81	0.702	583			
82	0.683	564			
83	0.665	547			





**Table 12 — Benshaw, Inc. Solid-State Starter Troubleshooting Guide**

Problem	Probable Causes	Area of Correction
AK board phase correct not on.	<ol style="list-style-type: none"> <li>1. L1 and L3 switch phases reversed.</li> <li>2. Missing phase voltage.</li> <li>3. Improper line voltage.</li> </ol>	<ol style="list-style-type: none"> <li>1. Switch incoming phases L1 and L3 at top of CD1 or CB1.</li> <li>2. Check for missing phase voltage.</li> <li>3. Verify proper line voltage applied against synchronizing transformer voltage.</li> </ol>
AK board relay not on.	Ribbon cable not properly seated.	Check ribbon cable for proper seating. Replace board if necessary.
AK board power +15 vdc not on.	<ol style="list-style-type: none"> <li>1. Improper line voltage.</li> <li>2. Transformer malfunction.</li> </ol>	<ol style="list-style-type: none"> <li>1. Make sure proper line voltage is present at primary synchronizing transformer.</li> <li>2. Check synchronizing transformer secondary voltage as follows: On the BC board, measure from TB11-1 to TB11-2 and TB11-1 to TB11-3. Both readings should be within 30 to 36 vac. On the BC board, measure from TB11-1 to TB11-4 and TB11-2 to TB11-4. Both readings should be within 18 to 24 vac. Replace synchronizing transformer if voltages are not within the specified tolerances.</li> </ol>
1L boards LEDs not on.	<ol style="list-style-type: none"> <li>1. A short exists between line and load terminals.</li> <li>2. An SCR is shorted in the phase assembly.</li> </ol>	<ol style="list-style-type: none"> <li>1. Remove power and check resistance with ohmmeter. Locate and remove stray wire strands if required.</li> <li>2. Remove power. Use ohmmeter to measure the resistance on each SCR phase assembly from anode to cathode. The reading should be 50,000 ohm or greater. If not, replace phase assembly.</li> </ol>
BC board over-temperature LED (L3) on prior to run command.	<ol style="list-style-type: none"> <li>1. Temperature switch not functioning properly.</li> <li>2. BC board not functioning properly.</li> </ol>	<ol style="list-style-type: none"> <li>1. Disconnect power and check for continuity between TB11-10 and TB11-11. If no continuity exists, the over-temperature switch is not functioning properly. Replace defective switch if necessary.</li> <li>2. Make sure BC board is functioning properly. Replace board if necessary.</li> </ol>
BC board LEDs on prior to run command.	BC board not functioning properly.	Board not functioning properly. Replace board, if necessary.
BC board LEDs not on after run command but before starter reaches full voltage.	<ol style="list-style-type: none"> <li>1. Phase assembly malfunction.</li> <li>2. BC board not functioning properly.</li> </ol>	<ol style="list-style-type: none"> <li>1. Remove power and check SCRs. Ohmmeter reading of each SCR gate to cathode resistance at terminals is 8 to 20 ohm. If not, replace the phase assembly.</li> <li>2. Replace board, if necessary.</li> </ol>
1L board LEDs remain on after starter reaches full voltage.	Imbalance between phases exists in motor terminal voltages.	Check for loose SCR gate lead or open SCR gate. Replace phase assembly, if necessary.
BC board run LED (L5) not lit.	BC board not functioning properly.	Measure 24 vdc at TB11-8 to TB11-4. If voltage is present, replace board. If not present, replace relay 1CR.



**Table 12 — Benschaw, Inc. Solid-State Starter Troubleshooting Guide (Continued)**

Problem	Probable Causes	Area of Correction
AK board power applied, run command given, starter at full voltage, but aux LED not lit.	AK board not functioning properly.	Replace board.
1L boards LEDs lit.	Motor terminal voltage phase imbalance exists.	Check motor terminal voltages for imbalance between phases. If an imbalance exists, check for loose SCR gate or open SCR gate. Replace phase assembly, if necessary.
BC board LED L4 and L5 not lit.	BC board not functioning properly.	Replace board.
BC board LED L3 lit.	<ol style="list-style-type: none"> <li>1. FU5 and FU6 fuses not functioning properly.</li> <li>2. Phase assembly not functioning properly.</li> <li>3. Fan not functioning properly.</li> </ol>	<ol style="list-style-type: none"> <li>1. Check fuses FU5 and FU6. Replace if necessary.</li> <li>2. Verify that bypass is pulling in by measuring the voltage drop across the contacts. The reading should be 50 mV or less. Replace phase assembly, if necessary.</li> <li>3. Verify fan operation on each phase for 200 amp units. Replace fan, if necessary.</li> </ol>
BC board L2 lit.	SCR phases not functioning properly.	Measure resistance from anode to cathode for each SCR phase assembly. Replace shorted phase, if necessary.
BC board L1 lit.	Motor lead grounded.	Megger motor to test for motor lead going to ground.
Start command given.	Motor does not begin rotation.	Turn 'Starting Torque' potentiometer RV2 clockwise until motor rotation begins.
Motor does not reach full speed within 25 seconds.	Ramp up setting is not correct.	Turn 'Ramp' potentiometer RV1 counterclockwise. Restart motor and verify that motor reaches full speed within 25 seconds.
115 vac missing from LL1 and LL2.	<ol style="list-style-type: none"> <li>1. CB2 is not on.</li> <li>2. Fuse no. 4 (FU4) blown.</li> </ol>	<ol style="list-style-type: none"> <li>1. Verify CB2 is on.</li> <li>2. Check FU4 for continuity. Replace, if necessary.</li> </ol>
SMM not responding.	<ol style="list-style-type: none"> <li>1. CB4 is not on.</li> <li>2. Potentiometer RV1 needs adjustment.</li> </ol>	<ol style="list-style-type: none"> <li>1. Verify CB4 is on.</li> <li>2. Adjust potentiometer RV1 for 24 vac at SMM terminals J3-23 and J3-24.</li> </ol>

Legend

**LED** — Light-Emitting Diode

**SCR** — Silicon Control Rectifier

**SMM** — Starter Management Module



**Table 13 — Cutler-Hammer® Solid-State Starter Troubleshooting Guide**

Problem	Probable Cause	Area of Correction
CB trips (electrically operated disconnecting means opens) as it is closed.	Motor is not connected.	Connect motor to starter.
	Incorrect phase sequence to the starter, 3-phase power not connected, or terminal loose.	Switch two incoming power leads. The 50 and 51 corresponding motor leads must also be switched to maintain the same motor rotation.
	Shorted SCR.	Perform shorted SCR check.
	Shunt trip contact between terminals closes due to shorted SCR.	Perform shorted SCR check.
	Shunt trip latching relay not reset (if used).	Reset STR relay by pushing RESET button on relay.
CB trips while motor is running.	Microprocessor detected non-standard operation.	Check wiring to logic module or replace logic module.
CB trips when STOP is pressed.	Voltage drop across SCR (looks like shorted SCR).	Check SCR.
Starter does not pick up and maintain.	Line voltage is not applied.	Check incoming lines for proper voltage.
	Overload is not reset.	Reset overload.
	120 v control voltage is not present.	Check control transformer fuse. Check control circuits.
	Heatsink overtemperature switches are open.	Check for continuity through overtemperature switches. Check that all fans are rotating freely. Check for excessive motor current draw.
Starter maintains but motor does not accelerate or does not attain full speed (stalls).	Current limit is too low.	Increase current limit setting clockwise. Set ramp time to minimum (counterclockwise).
Insufficient Torque.	Improper current feedback.	Check current feedback resistor for proper calibration.
	High breakaway torque required.	Load is not suitable for reduced voltage starting.
Motor accelerates too slowly.	Current limit is too low.	Increase current limit setting clockwise.
	Ramp time is too long.	Decrease ramp time setting counterclockwise.
	Broken current feedback resistor.	Check by recalibrating CFR.



**Table 13 — Cutler-Hammer® Solid-State Starter Troubleshooting Guide (Continued)**

<b>Problem</b>	<b>Probable Cause</b>	<b>Area of Correction</b>
Motor accelerates too quickly.	Current limit is too high.	Decrease current limit setting counterclockwise.
	Improper current feedback.	Check current calibrator for proper resistance value.
	Pulse start setting is too long.	Decrease pulse start time counterclockwise.
	Broken current feedback transformer wire.	Check for a broken current feedback transformer wire.
Current limit adjustment has no effect during acceleration.	Improper current feedback.	Check current calibrator for proper resistance value.
Starter or motor is noisy or vibrates when starting.	Single phasing due to open phase.	Check wiring and overload heater coils.
	Single phasing or unbalanced current due to non-firing SCR.	Check gate lead wiring to SCRs.
	Defective motor.	Check motor for shorts, opens, and grounds.
Mechanical shock to machine.	Current increases too quickly.	Decrease starting current counterclockwise. If necessary, increase ramp time clockwise.
End of limit contact does not close.	Starter is in current limit.	Perform SCR full voltage test.
Current trip contact does not close when current goes above the trip setting.	Improper current feedback.	Check current calibrator for proper resistance value.
Current trip contact closes when current is below trip setting.	Improper current feedback.	Check current calibrator for proper resistance value.
Motor current, voltage, and speed oscillate.	Power saver is misadjusted.	Turn power saver adjustment CCW until oscillations cease.



**Table 13 — Cutler-Hammer® Solid-State Starter Troubleshooting Guide (Continued)**

<b>Problem</b>	<b>Probable Cause</b>	<b>Area of Correction</b>
Overload relay trips when starting.	Incorrect heater coils (melting allow).	Check heater coil rating.
	Loose heater coil.	Tighten heater coil.
	Long starting time (high inertia applications may require slow trip overload and oversize starter).	Motor and starter thermal capabilities must be evaluated before extending overload trip times.
	Mechanical problems.	Check machinery for binding or excessive loading.
	Single phasing.	See “Starter or motor is noisy or vibrates when starting” symptom in troubleshooting table.
	Excessive starting time (current limit may be set too low).	Increase current limit setting clockwise.
Overload relay trips when running.	Incorrect heater coils (melting alloy).	Check heater coil rating.
	Mechanical problems.	Check machinery for binding or excessive loading.
	Single phasing.	See “Starter or motor is noisy or vibrates when starting” problem in troubleshooting table.
Heatsink overtemperature switch opens.	Excessive current.	Check motor current draw.
	Defective heatsink, fan.	Check that all fans are rotating freely.
Erratic operation.	Loose connections.	Check all connections.

Legend

**CCW** — Counter Clockwise

**CFR** — Current Feedback Resistor

**STR** — Shunt Trip Relay





**Table 14 — Heat Exchanger Data**

Vessel	Heat Exchanger Code	Number of Tubes	Rigging Weights				Vessel Charge					
			Dry Wt.				Refrigerant				Volume of Water	
			Design I		Design II		Design I		Design II			
			Lb	Kg	Lb	Kg	Lb	Kg	Lb	Kg	Gal	L
Cooler	40	201	5000	2275	5340	2422	1020	463	920	417	53	201
	41	227	5150	2350	5485	2488	1090	494	990	499	58	220
	42	257	5325	2425	5655	2565	1150	522	1050	476	64	242
	43	290	5500	2500	5845	2651	1200	544	1100	499	71	269
	50	314	6625	3000	7020	3184	1450	658	1300	590	79	299
	51	355	6850	3100	7255	3291	1500	680	1350	612	87	329
	52	400	7100	3225	7510	3406	1580	717	1430	649	96	363
	53	445	7375	3350	7770	3524	1650	748	1500	680	104	394
	55	201	—	—	8510	3860	—	—	1840	834	104	395
	56	227	—	—	8845	4012	—	—	1910	860	115	438
	57	257	—	—	9205	4175	—	—	2020	916	128	486
	58	290	—	—	9575	4343	—	—	2120	962	140	531
Condenser	40	218	5050	2100	4855	2202	400	181	350	159	56	212
	41	246	5200	2350	5010	2272	400	181	350	159	62	235
	42	279	5375	2450	5180	2350	400	181	350	159	68	257
	43	315	5575	2525	5370	2436	400	181	350	159	75	284
	50	347	7050	3200	6750	3062	400	181	350	159	84	318
	51	387	7275	3300	6960	3157	400	181	350	159	92	348
	52	432	7500	3400	7200	3266	400	181	350	159	101	382
	53	484	7775	3525	7475	3391	400	181	350	159	110	416
	55	218	—	—	8345	3785	—	—	490	222	112	423
	56	246	—	—	8635	3917	—	—	490	222	123	466
	57	279	—	—	8980	4073	—	—	490	222	135	513
	58	315	—	—	9370	4250	—	—	490	222	149	565



**Table 15 — Additional Data for Marine Waterboxes\***

Heat Exchanger Frame, Pass	English				SI			
	Rigging Wt (lb)		Water Volume (gal)		Rigging Wt (kg)		Water Volume (L)	
	Cooler	Condenser	Cooler	Condenser	Cooler	Condenser	Cooler	Condenser
Frame 4, 2 Pass	1115	660	69	51	506	300	261	193
Frame 4, 1 & 3 Pass	2030	1160	138	101	922	527	524	384
Frame 5, 2 Pass	1220	935	88	64	554	424	331	243
Frame 5, 1 & 3 Pass	2240	1705	175	128	1017	774	663	486

\* Add to heat exchanger weights and volumes for total weight or volume.



**Table 16 — Compressor Weights**

<b>Component</b>	<b>Weight</b>	
	<b>Lb</b>	<b>Kg</b>
<b>Suction Elbow</b>	55	25
<b>Discharge Elbow</b>	50	23
<b>Transmission</b>	730	331
<b>Suction Housing</b>	350	159
<b>Impeller Shroud</b>	80	36
<b>Compressor Base</b>	1050	476
<b>Diffuser</b>	70	32
<b>Oil Pump</b>	150	68
<b>Miscellaneous</b>	135	61
<b>Total Weight (Less Motor)</b>	2660	1207





**Table 17 — Compressor/Motor Weights**

Motor Size	English						SI					
	Compressor Weight (lb)	Stator Weight (lb)		Rotor Weight (lb)		End Bell Cover (lb)	Compressor Weight (lb)	Stator Weight (kg)		Rotor Weight (kg)		End Bell Cover (lb)
		60 Hz	50 Hz	60 Hz	50 Hz			60 Hz	50 Hz	60 Hz	50 Hz	
<b>CD</b>	2660	1153	1213	234	252	250	1208	523	551	106	114	114
<b>CE</b>	2660	1162	1227	237	255	250	1208	528	557	108	116	114
<b>CL</b>	2660	1202	1283	246	270	250	1208	546	582	112	123	114
<b>CM</b>	2660	1225	1308	254	275	250	1208	556	594	115	125	114
<b>CN</b>	2660	1276	1341	263	279	250	1208	579	609	119	127	114
<b>CP</b>	2660	1289	1356	266	284	250	1208	585	616	121	129	114
<b>CQ</b>	2660	1306	1363	273	287	250	1208	593	619	124	130	114
<b>CR</b>	2660	1335	1384	282	294	250	1208	606	628	128	133	114

**Note:** For medium voltage motors add 85 lbs (39 kg) to above for 60 Hz motors and 145 lbs (66 kg) for 50 Hz motors. Total compressor/motor weight is the sum of the compressor, stator, rotor, and end bell cover weight. Compressor weight includes suction and discharge elbow weights.



**Table 18 — Waterbox Cover Weights\* (English (lb))**

Heat Exchanger	Waterbox Description	Frame 4, Std. Nozzles		Frame 4, Flanged		Frames, Std. Nozzles		Frames, Flanged	
		150 psig	300 psig	150 psig	300 psig	150 psig	300 psig	150 psig	300 psig
<b>Coolers</b>	NIH, 1 Pass Cover	284	414	324	491	412	578	452	655
	NIH, 2 Pass Cover	285	411	341	523	410	573	466	685
	NIH, 3 Pass Cover	292	433	309	469	423	602	440	638
	NIH, Plain End Cover	243	292	243	292	304	426	304	426
	MWB Cover	CS	621	CS	621	CS	766	CS	766
	Plain End Cover	CS	482	CS	482	CS	471	CS	471
<b>Condensers</b>	NIH, 1 Pass Cover	306	446	346	523	373	472	413	549
	NIH, 2 Pass Cover	288	435	344	547	368	469	428	541
	NIH, 3 Pass Cover	319	466	336	502	407	493	419	549
	NIH, Plain End Cover	226	271	226	271	271	379	271	379
	MWB Cover	CS	474	CS	474	CS	590	CS	590
	Plain End Cover	CS	359	CS	359	CS	428	CS	428

Legend

**NIH** — Nozzle-in-Head

**MWB** — Marine Waterbox

**CS** — Contact Syracuse

\* These weights are for reference only.

**Note:** The 150 psig (1034 kPa) standard waterbox cover weights have been included in the heat exchanger weights shown in [Table 14](#).



**Table 18 — Waterbox Cover Weights\* (SI (kg)) (Continued)**

Heat Exchanger	Waterbox Description	Frame 4, STD. Nozzles		Frame 4, Flanged		Frames, STD. Nozzles		Frames, Flanged	
		1034 kPa	2068 kPa	1034 kPa	2068 kPa	1034 kPa	2068 kPa	1034 kPa	2068 kPa
<b>Coolers</b>	NIH, 1 Pass Cover	129	188	147	223	187	262	205	297
	NIH, 2 Pass Cover	129	187	155	237	186	260	212	311
	NIH, 3 Pass Cover	133	197	140	213	192	273	200	290
	NIH, Plain End Cover	110	133	110	133	138	193	138	193
	MWB Cover	CS	282	CS	282	CS	348	CS	348
	Plain End Cover	CS	219	CS	219	CS	214	CS	214
<b>Condensers</b>	NIH, 1 Pass Cover	139	202	157	237	169	214	188	249
	NIH, 2 Pass Cover	131	197	156	248	167	213	194	246
	NIH, 3 Pass Cover	145	212	153	228	185	224	190	249
	NIH, Plain End Cover	103	123	103	123	123	172	123	172
	MWB Cover	CS	215	CS	215	CS	268	CS	268
	Plain End Cover	CS	163	CS	163	CS	194	CS	194

Legend

**NIH** — Nozzle-in-Head

**MWB** — Marine Waterbox

**CS** — Contact Syracuse

\* These weights are for reference only.

**Note:** The 150 psig (1034 kPa) standard waterbox cover weights have been included in the heat exchanger weights shown in [Table 14](#).



**Table 19 — Optional Pumpout System Electrical Data**

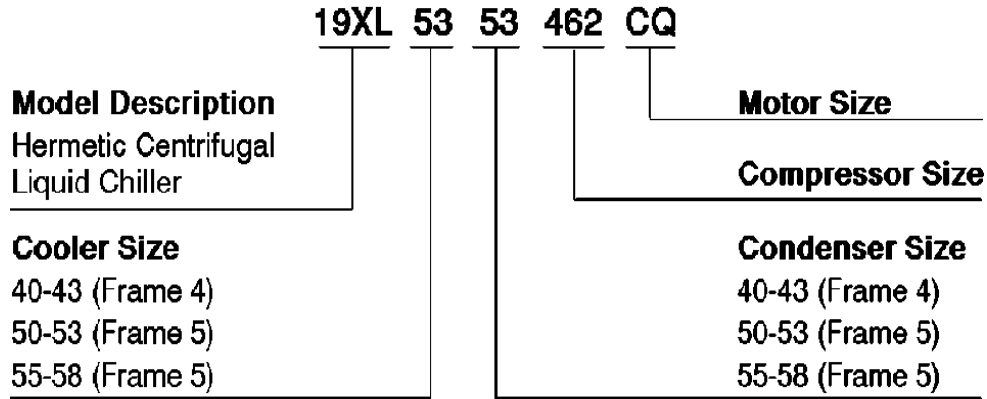
<b>Motor Code</b>	<b>Condenser Unit</b>	<b>Volts-PH-HZ</b>	<b>Max RLA</b>	<b>LRA</b>
<b>1</b>	19EA47-748	575-3-60	3.8	23.0
<b>4</b>	19EA42-748	200/208-3-60	10.9	63.5
<b>5</b>	19EA44-748	230-3-60	9.5	57.5
<b>6</b>	19EA46-748	400/460-3-50/60	4.7	28.8

Legend

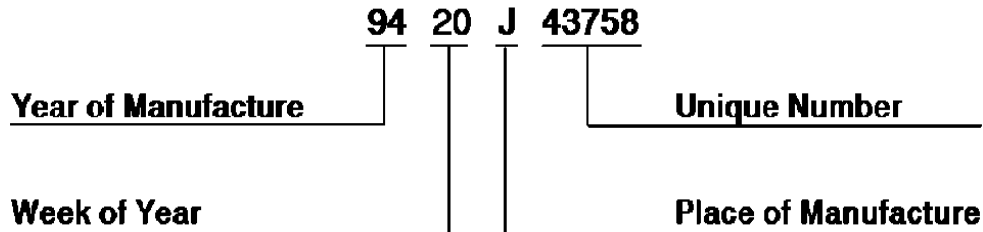
**LRA** — Locked Rotor Amps

**RLA** — Rated Load Amps





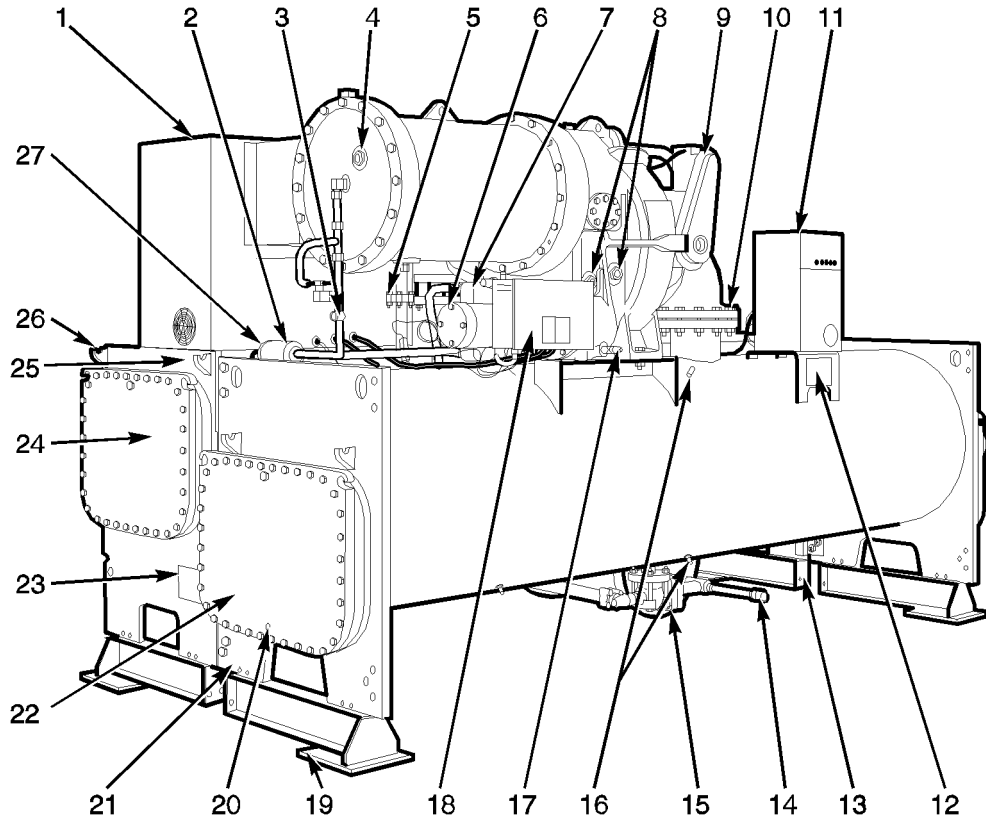
### MODEL NUMBER NOMENCLATURE



### SERIAL NUMBER BREAKDOWN

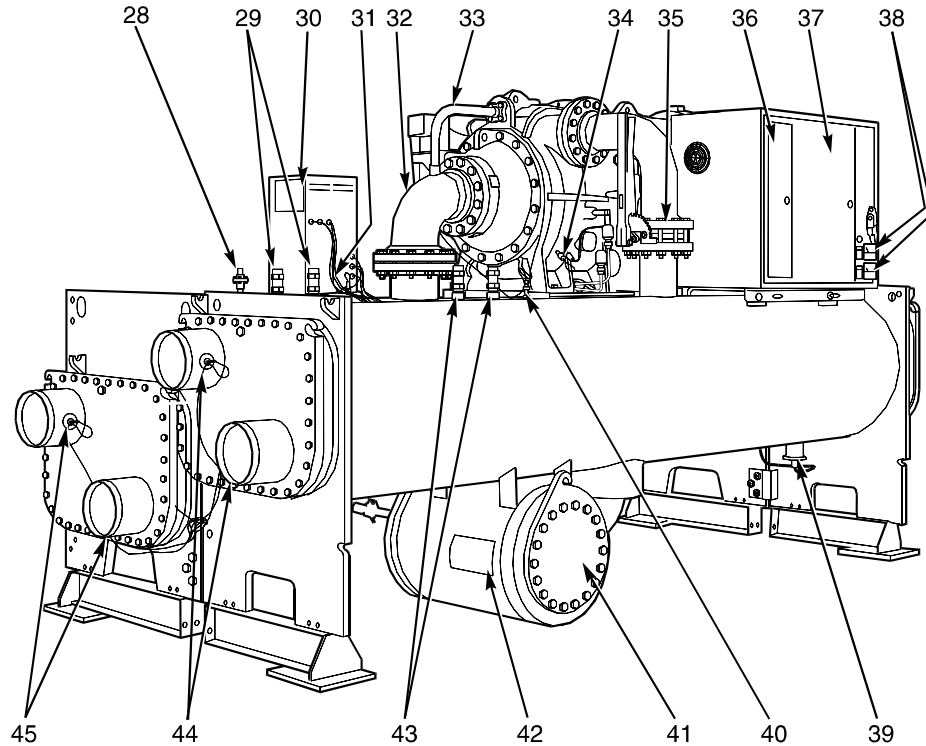
**Figure 1 — 19XL Identification**





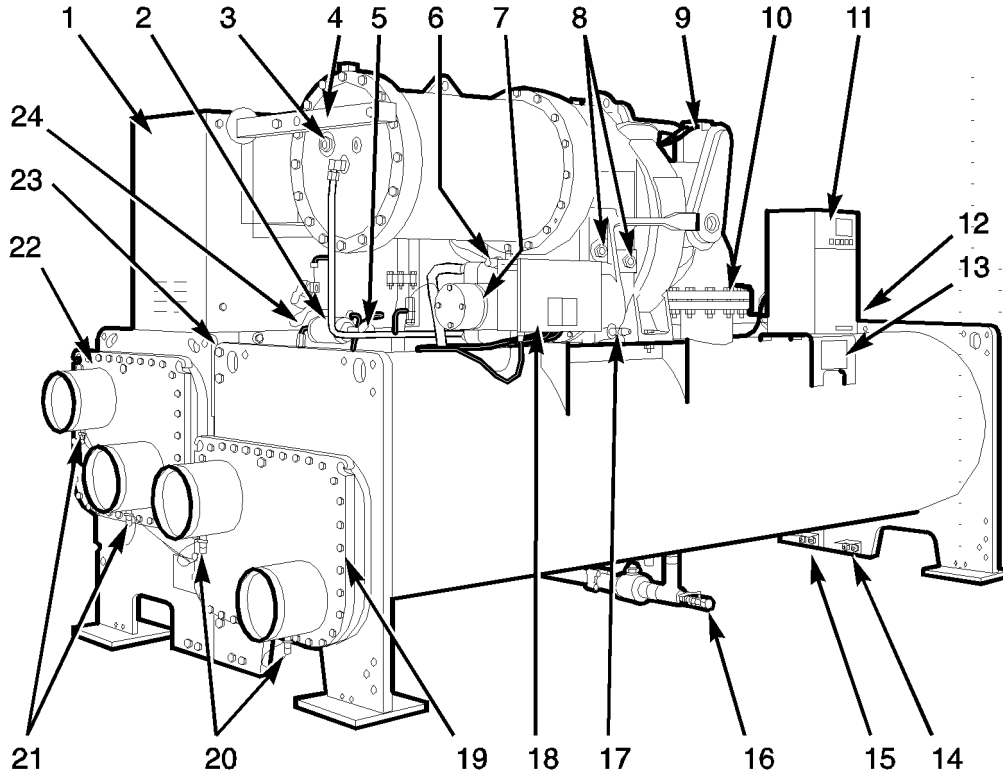
**Figure 2A (Front View) — Typical 19XL  
Components — Design I (See next page for Rear View)**





**Figure 2A (Rear View) — Typical 19XL  
Components — Design I**

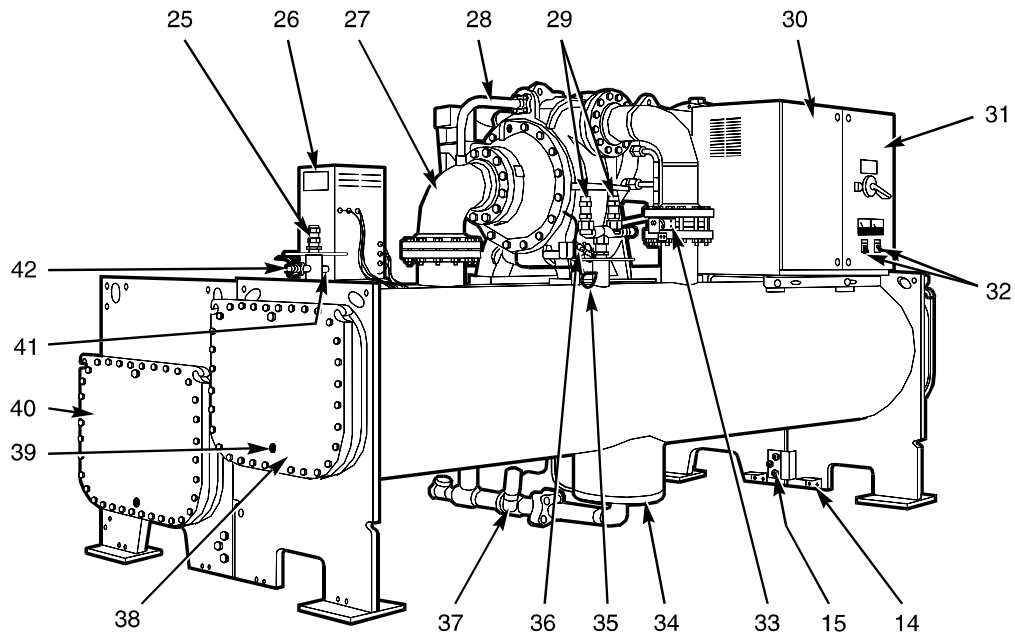




**Figure 2B (Front View) — Typical 19XL  
Components — Design II (See next page for Rear View)**

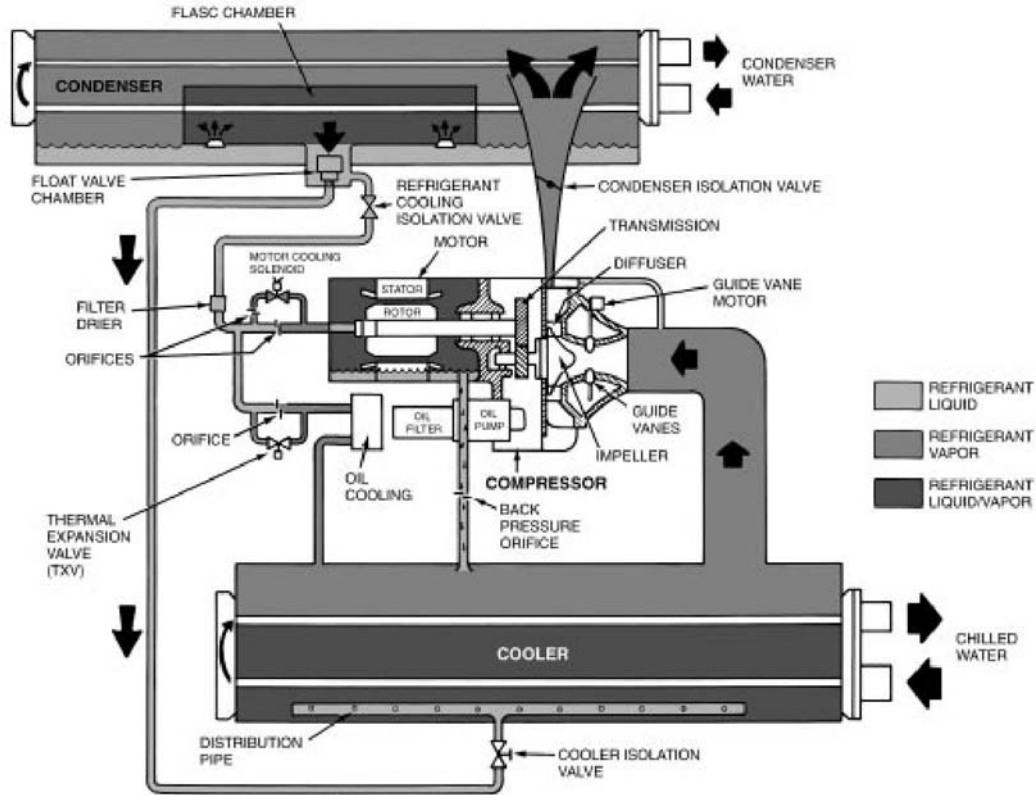






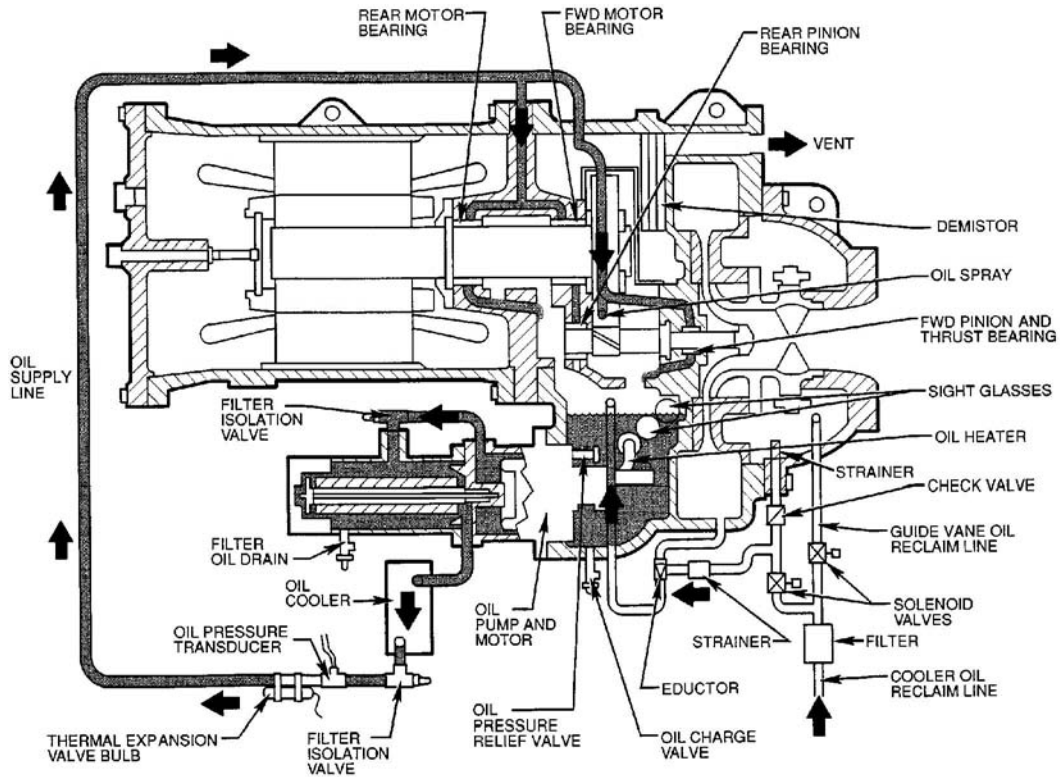
**Figure 2B (Rear View) — Typical 19XL  
Components — Design II**





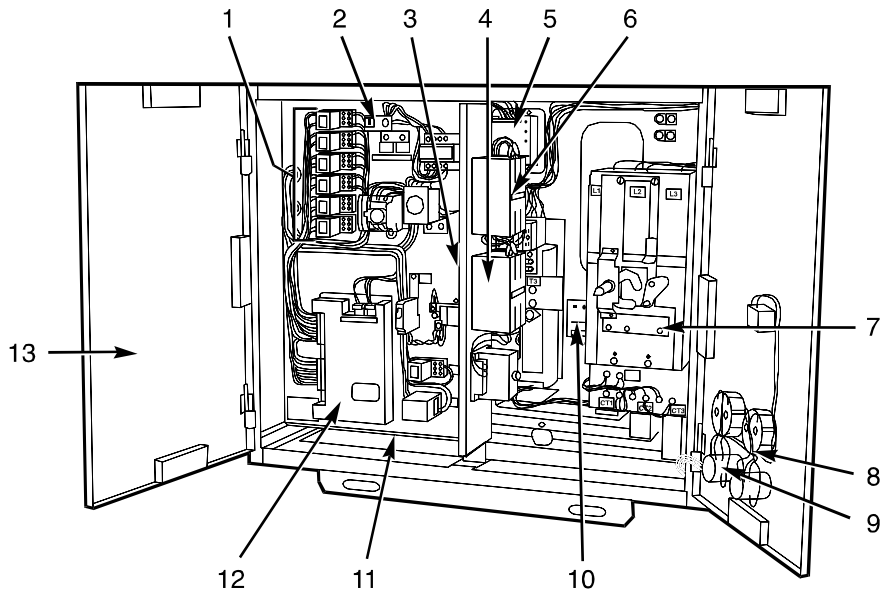
**Figure 3 — Refrigerant Motor Cooling and Oil Cooling Cycles**





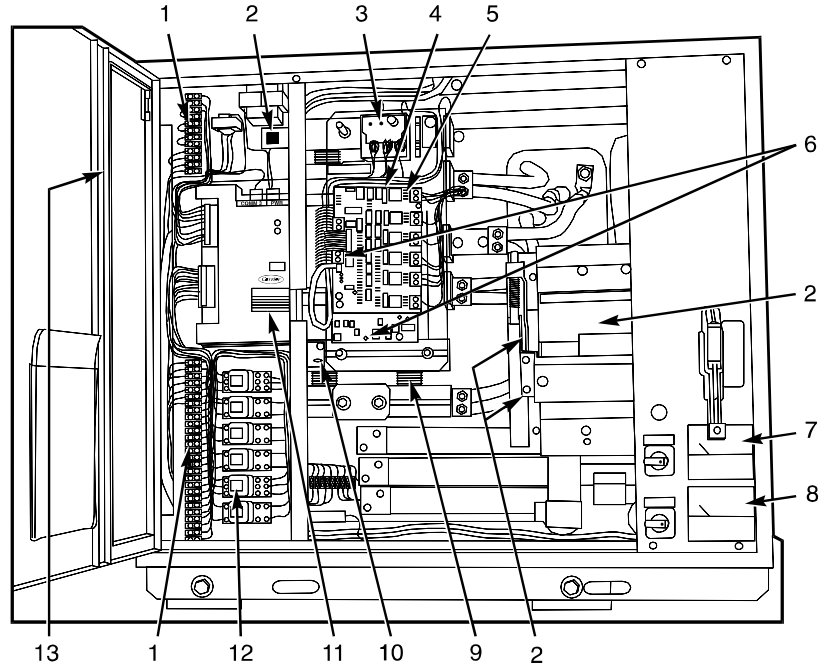
**Figure 4 — Lubrication System**





**Figure 5 — Cutler-Hammer Solid-State Starter,  
Internal View**



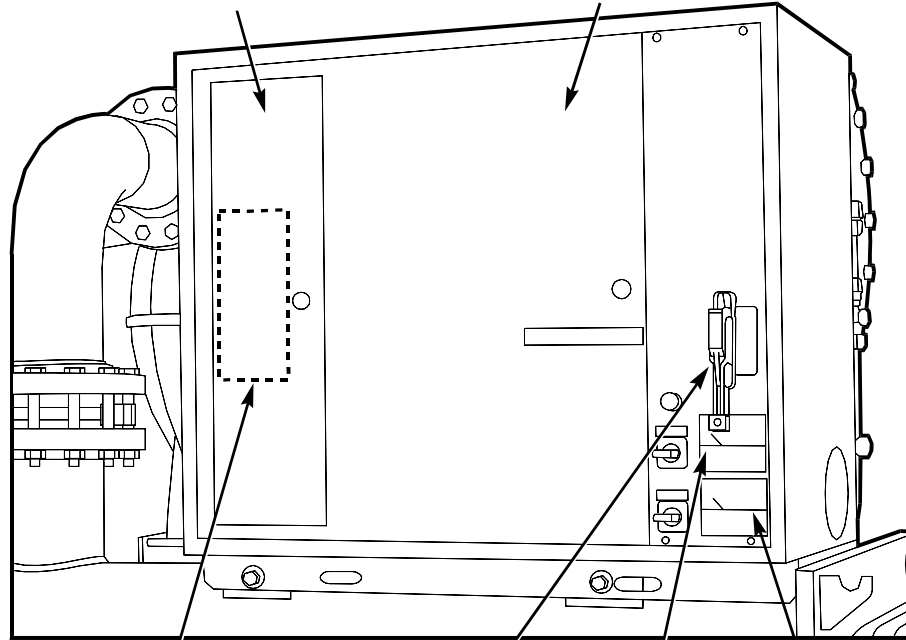


**Figure 6 — Benshaw, Inc. Solid-State Starter,  
Internal View**



LOW VOLTAGE (120 V OR LESS)  
AND FIELD WIRING ACCESS PANEL

STARTER ACCESS  
DOOR



SMM MODULE  
(BEHIND DOOR)

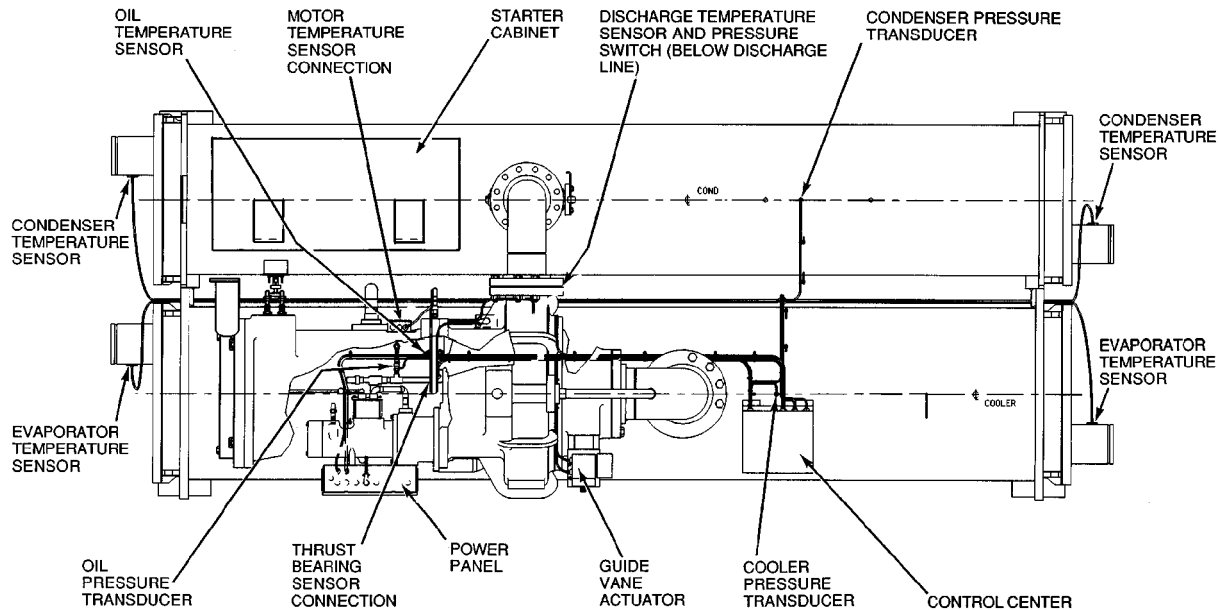
MOTOR POWER  
DISCONNECT  
HANDLE

AC  
VOLTS

AC  
AMPS

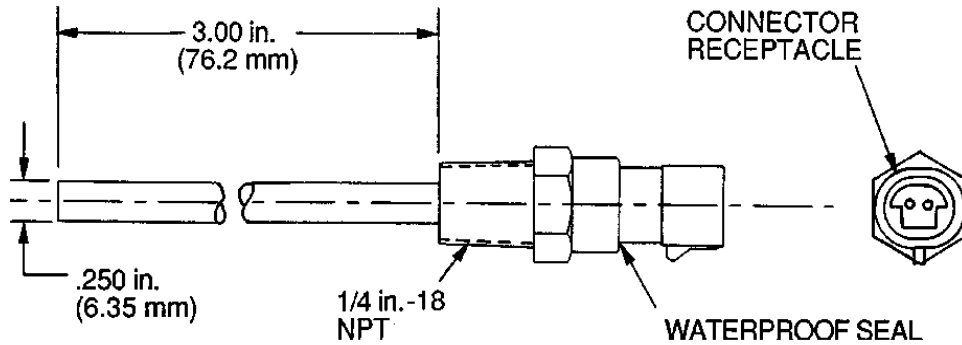
**Figure 7 — Typical Starter Front View  
(Solid-State Starter Shown)**





**Figure 8 — 19XL Controls and Sensor Locations**

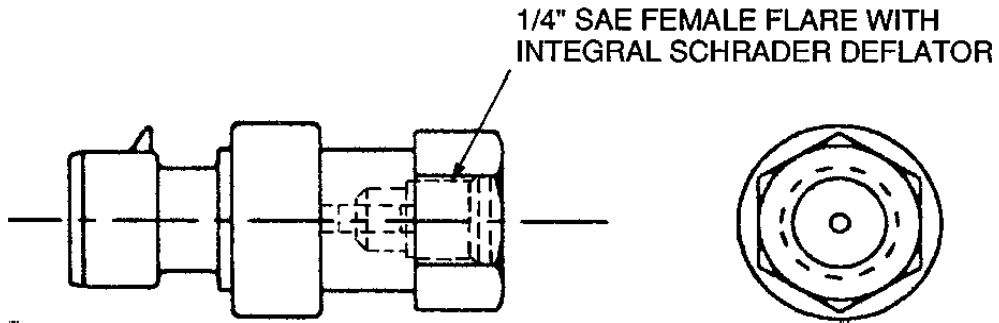




**Figure 9 — Control Sensors  
(Temperature)**

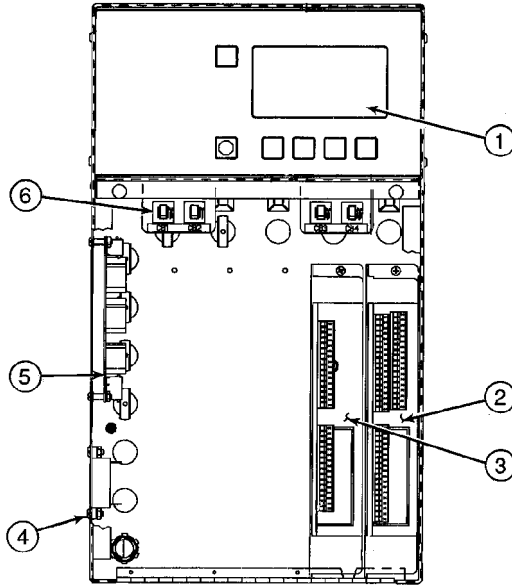






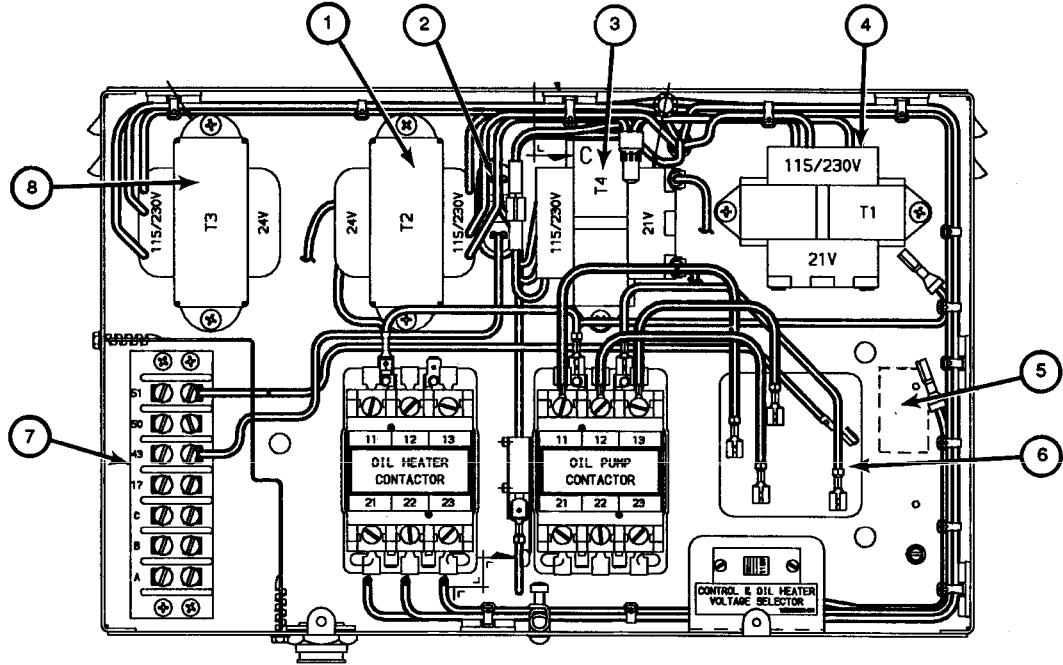
**Figure 10 — Control Sensors  
(Pressure Transducer, Typical)**





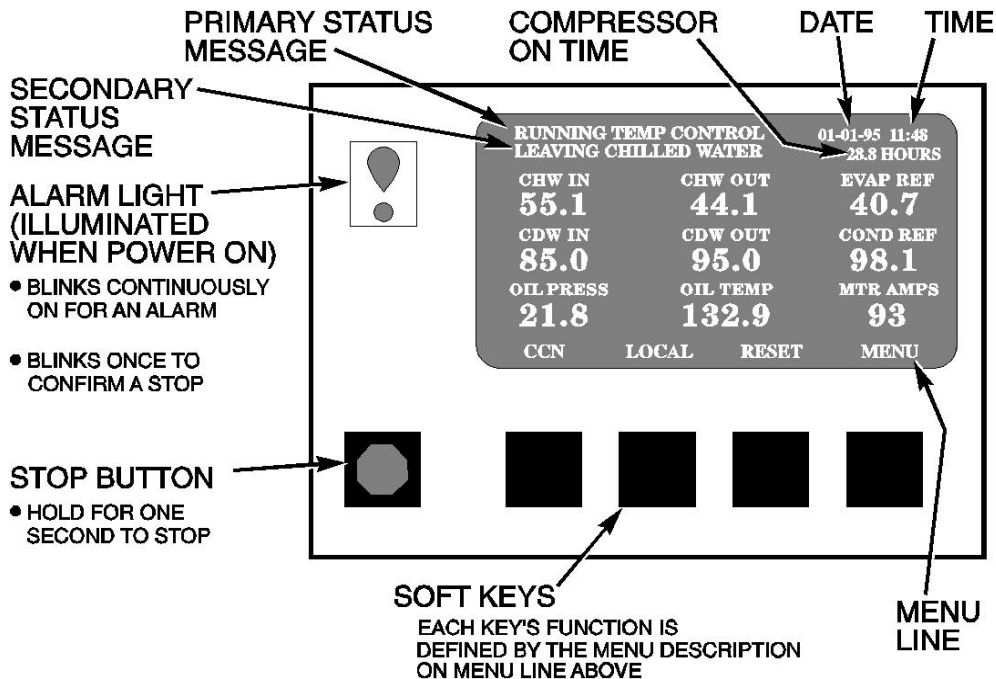
**Figure 11 — Control Panel (Front View),  
with Options Module**





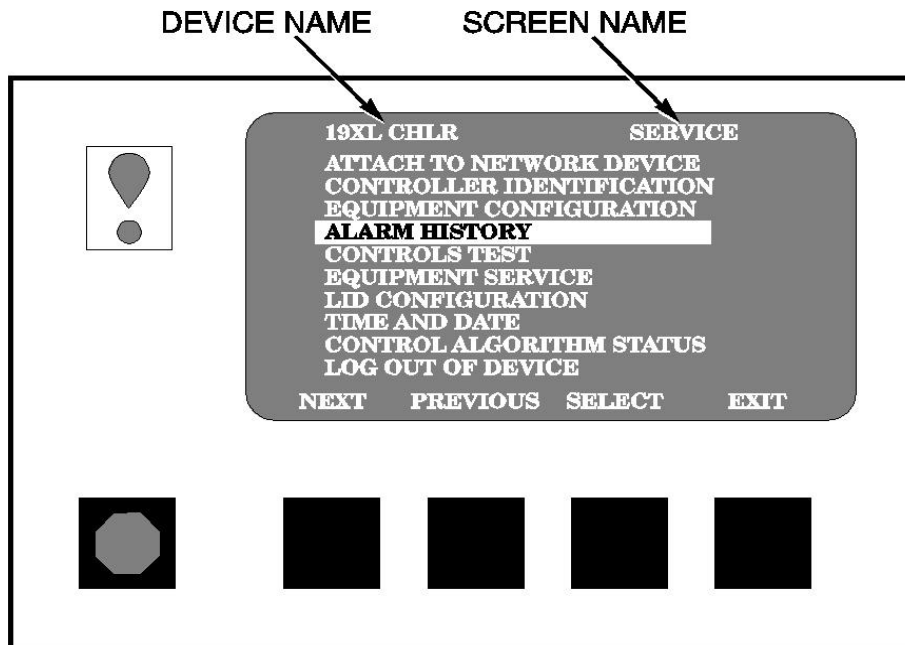
**Figure 12 — Power Panel with Options**





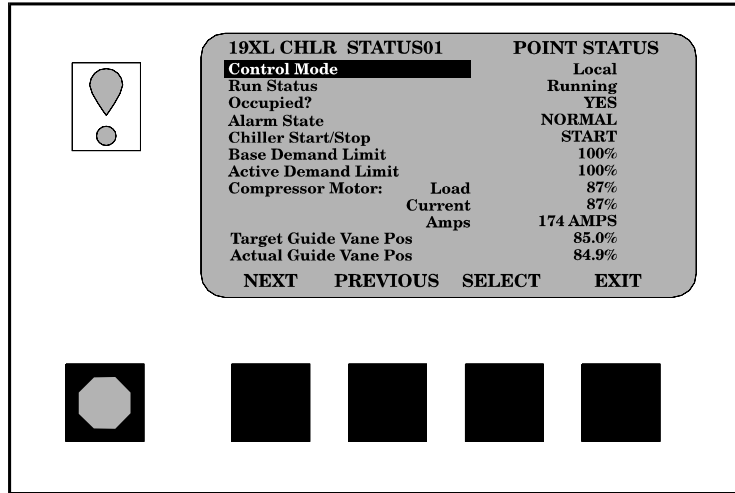
**Figure 13 — LID Default Screen**





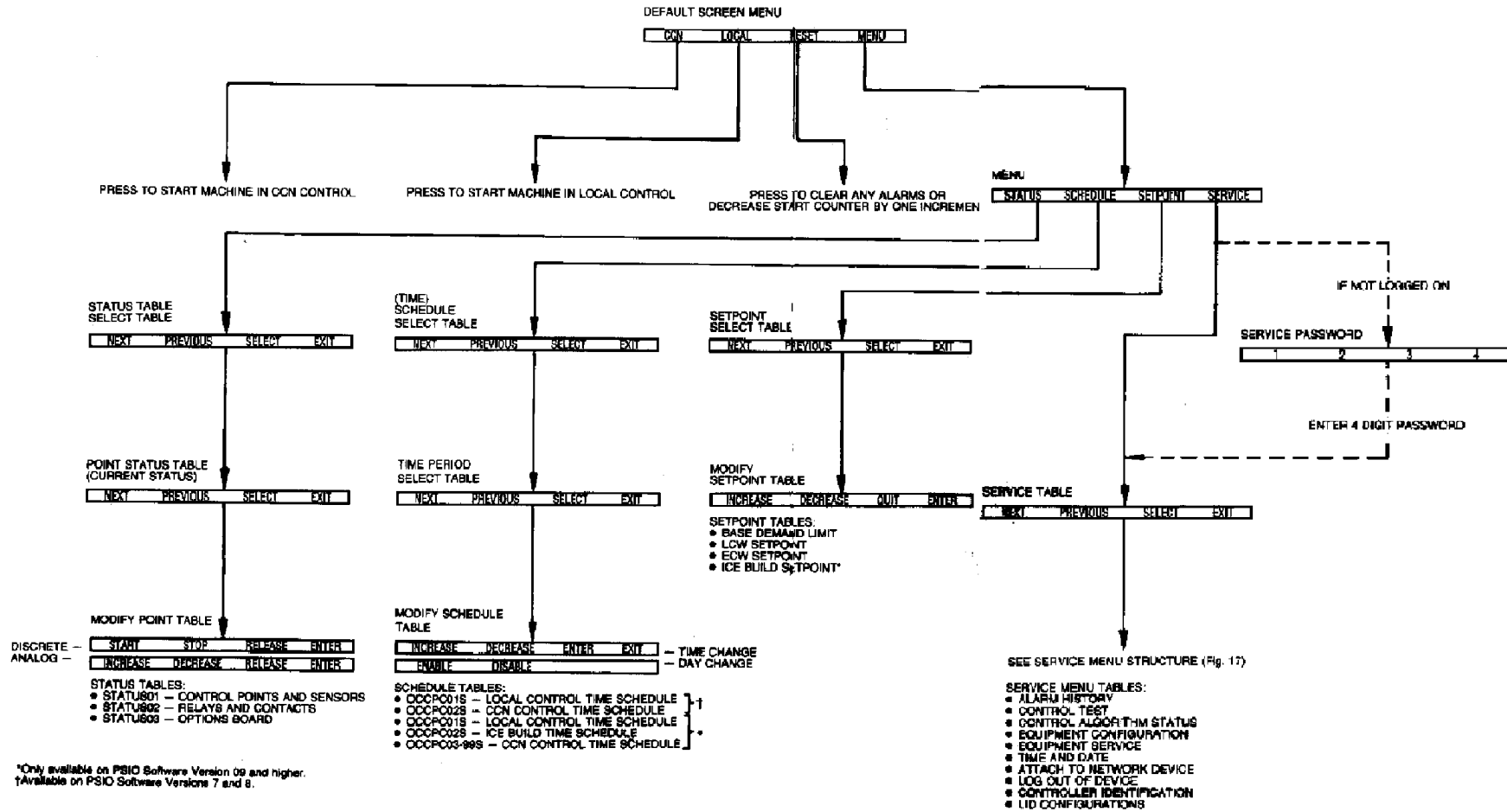
**Figure 14 — LID Service Screen**





**Figure 15 — Example of Point Status Screen (Status01)**





**Figure 16 — 19XL Menu Structure**



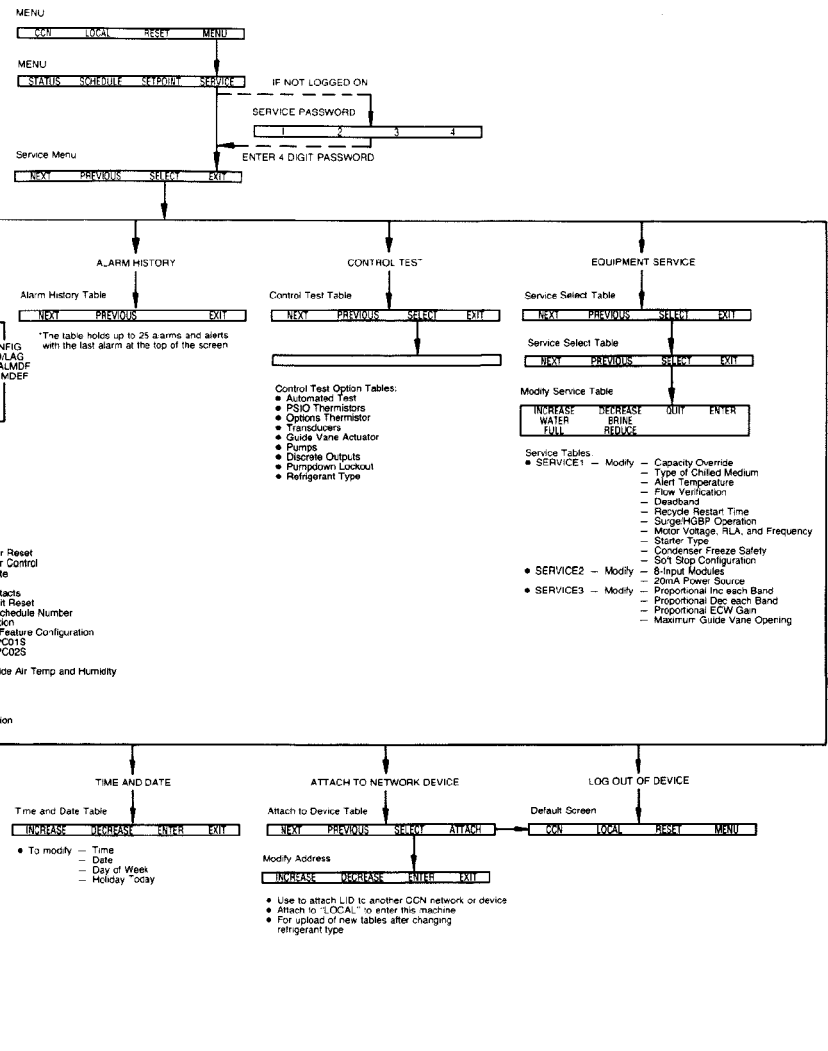



Figure 17 — 19XL Service Menu Structure






**19XL CHLR OCC PC01S      TIME PERIOD SELECT**

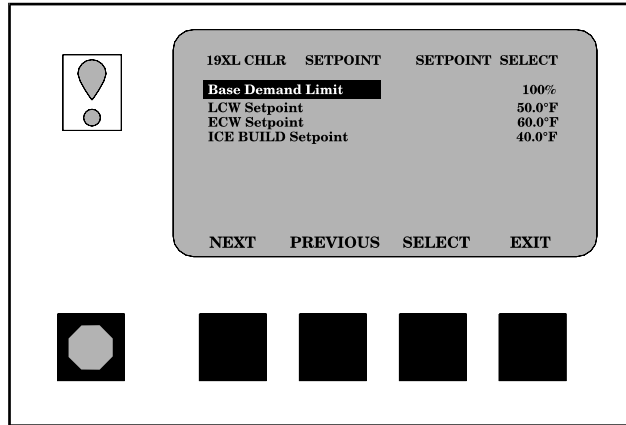
PERIOD	ON	OFF	M	T	W	T	F	S	S	H
1	0700	1800	X	X	X	X	X			
2	0600	1300							X	
3	0000	0300		X						
4	0000	0000								
5	0000	0000								
6	0000	0000								
7	0000	0000								
8	0000	0000								
OVERVERRIDE	0 HOURS									

NEXT
PREVIOUS
SELECT
EXIT



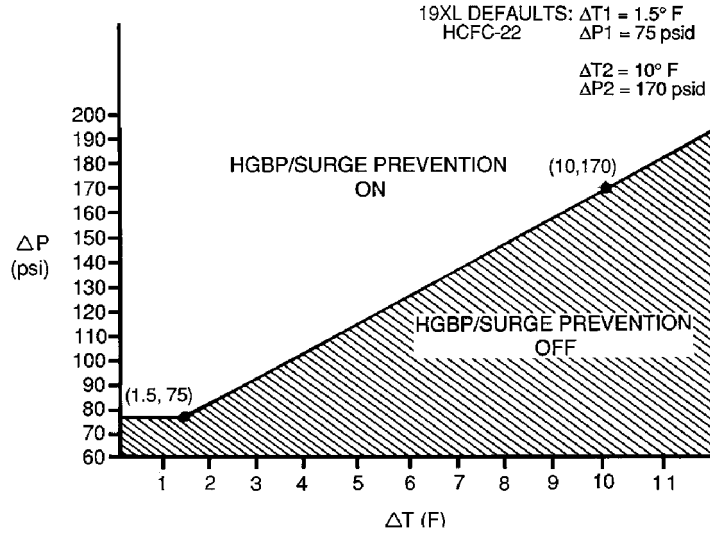
**Figure 18 — Example of Time Schedule Operation Screen**





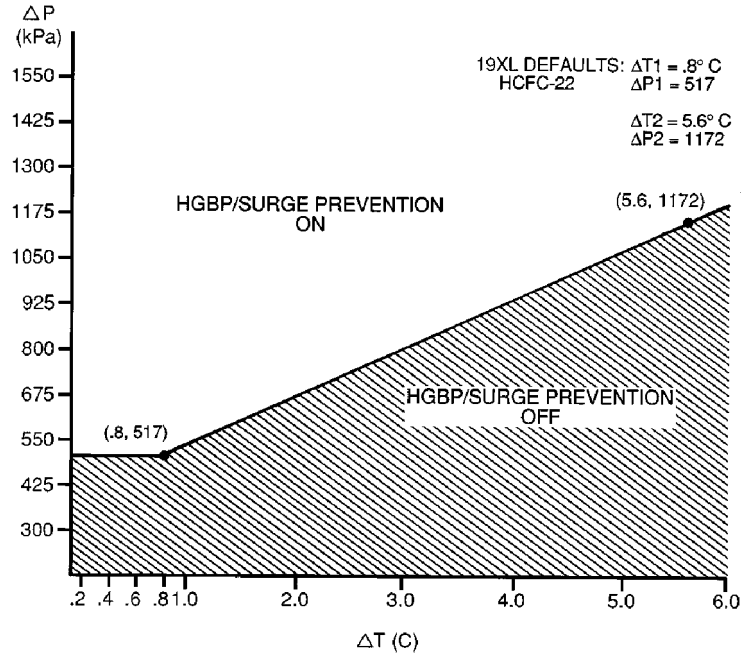
**Figure 19 — Example of Set Point Screen**





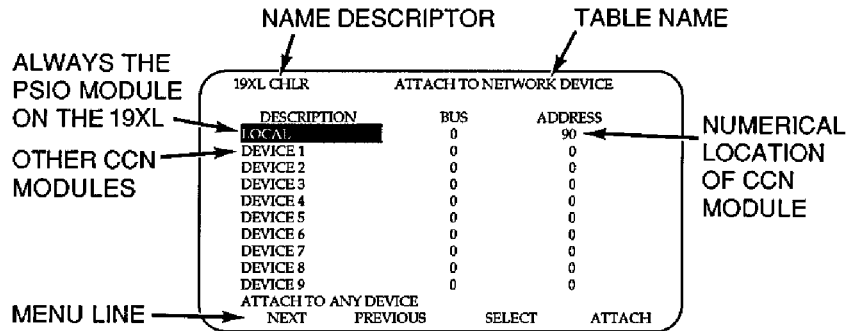
**Figure 20 — 19XL Hot Gas Bypass/Surge Prevention**





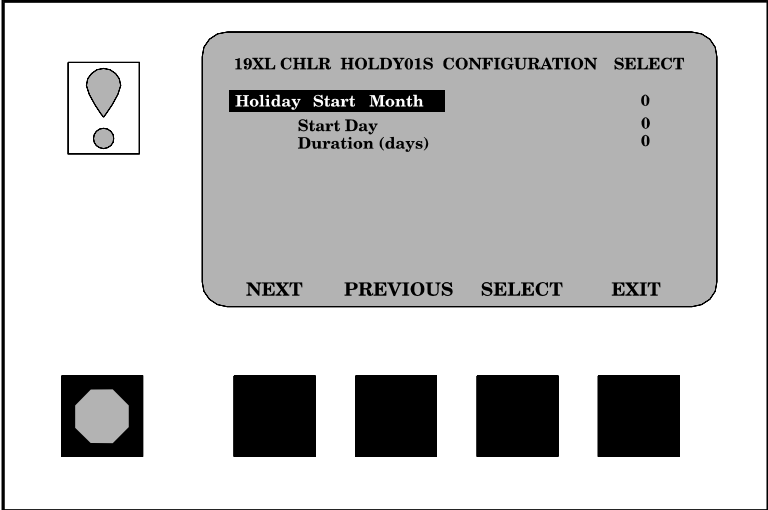
**Figure 21 — 19XL with Default Metric Settings**





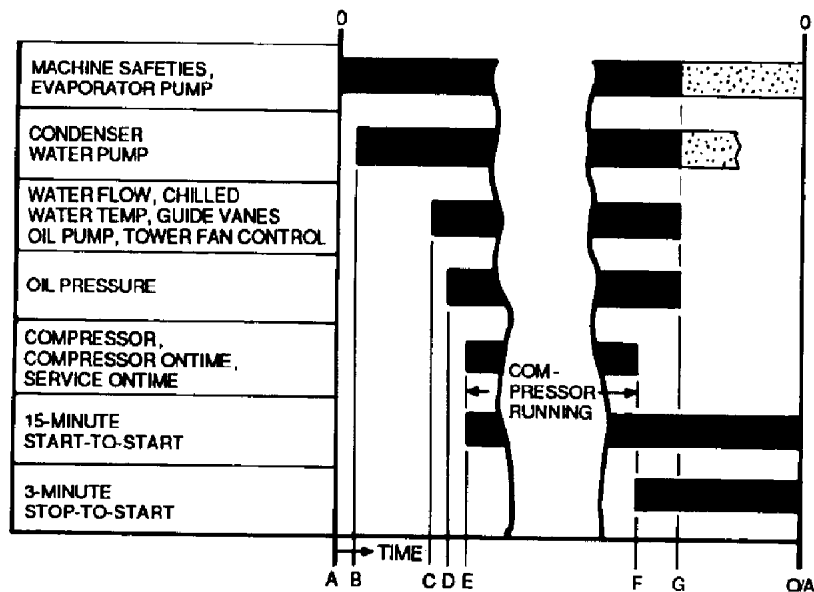
**Figure 22 — Example of Attach to Network Device Screen**





**Figure 23 — Example of Holiday Period Screen**

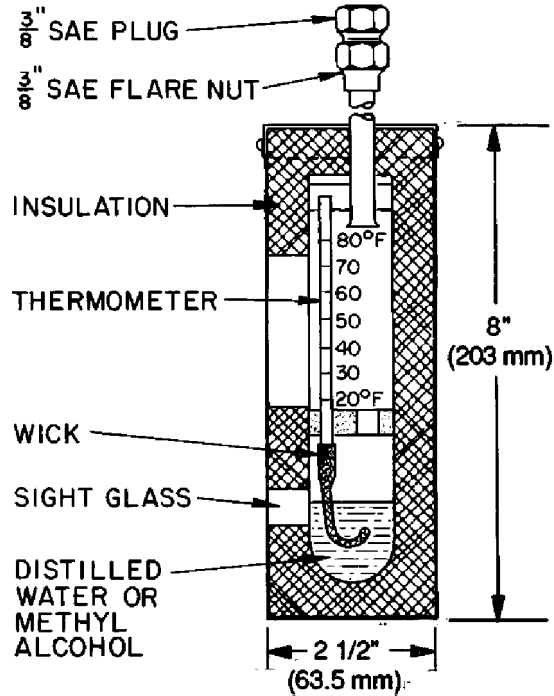




- A — START INITIATED — Prestart checks made; evaporator pump started
- B — Condenser water pump started (5 seconds after A)
- C — Water flows verified (30 seconds to 5 minutes maximum after B). Chilled water temperatures checked against control point. Guide vanes checked for closure. Oil pump started; tower fan control enabled.
- D — Oil pressure verified (15 seconds minimum, 300 seconds maximum after C)
- E — Compressor motor starts, compressor ontime and service ontime start, 15-minute inhibit timer starts (10 seconds after D)
- F — SHUTDOWN INITIATED — Compressor motor stops, compressor ontime and service ontime stops, 3-minute inhibit timer starts on PSIO Software Version 08 and lower and 1-minute inhibit timer starts for PSIO Software Version 09 and higher.
- G — Oil pump and evaporator pumps deenergized (60 seconds after F). Condenser pump and tower fan control may continue to operate if condenser pressure is high. Evaporator pump may continue if in RECYCLE mode.
- O/A — Restart permitted (both inhibit timers expired) (minimum of 15 minutes after E; [minimum of 3 minutes after F on PSIO Software Version 08 and lower] [minimum of 1 minute after F on PSIO Software Version 09 and higher])

**Figure 24 — Control Sequence**

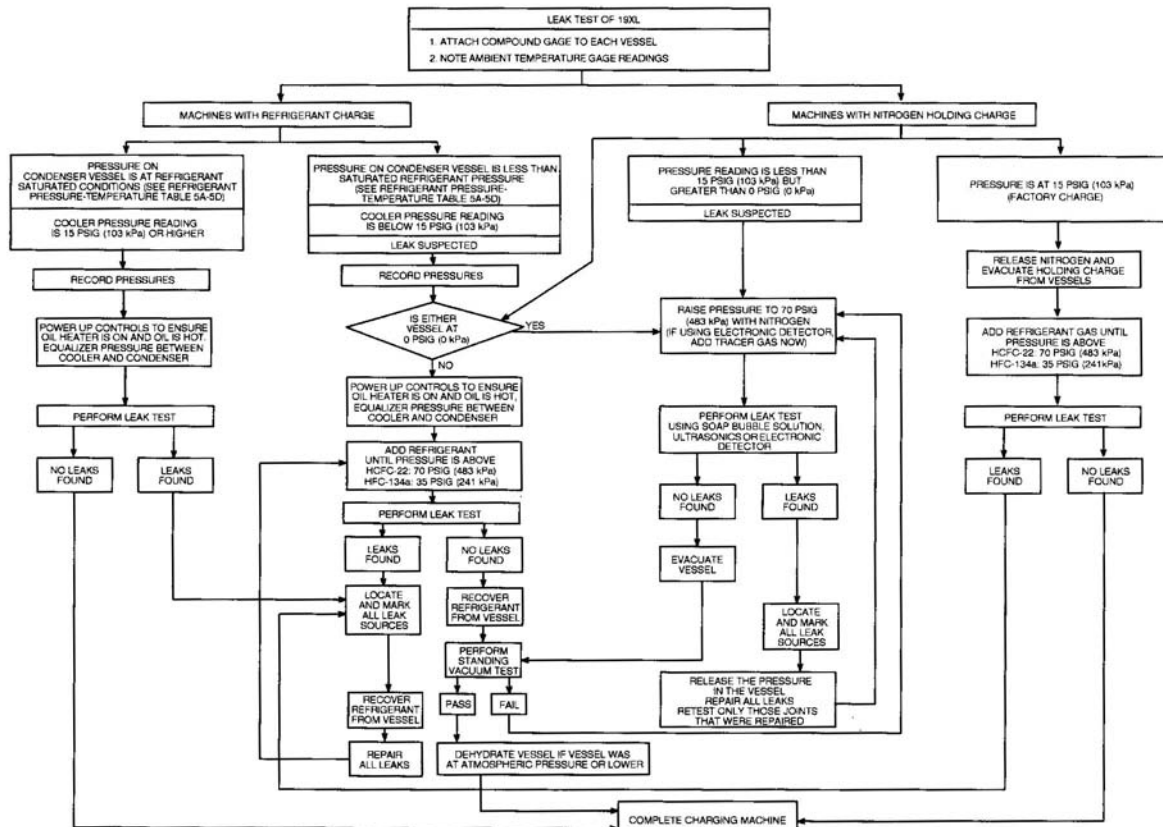




**Figure 25 — Typical Wet-Bulb Type Vacuum Indicator**

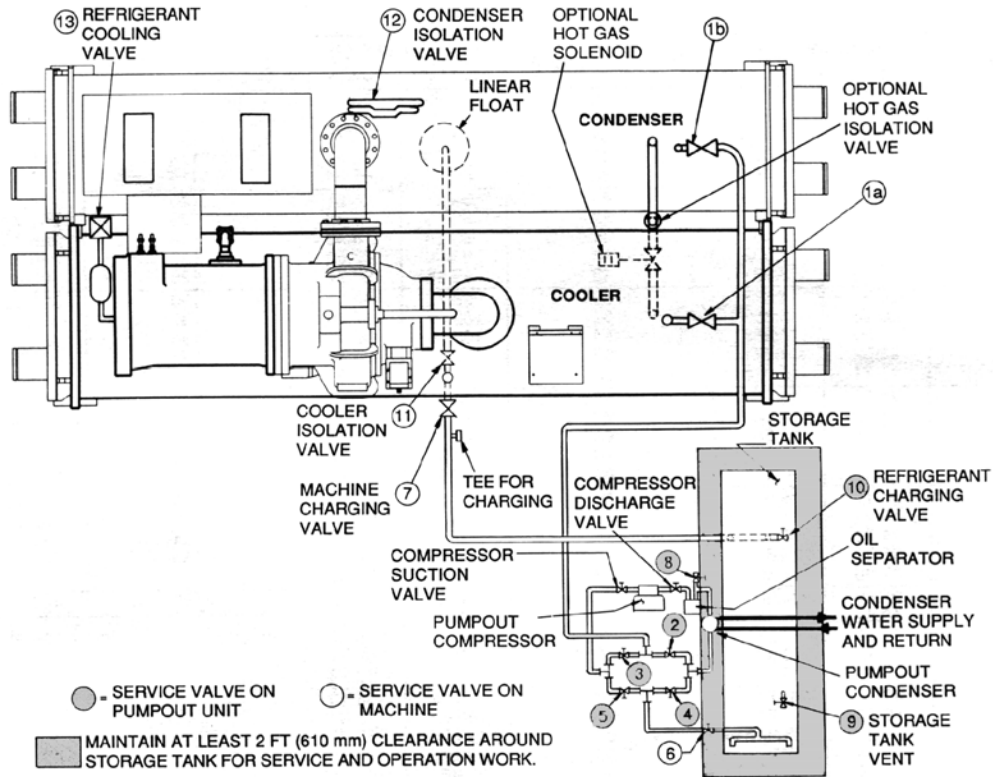






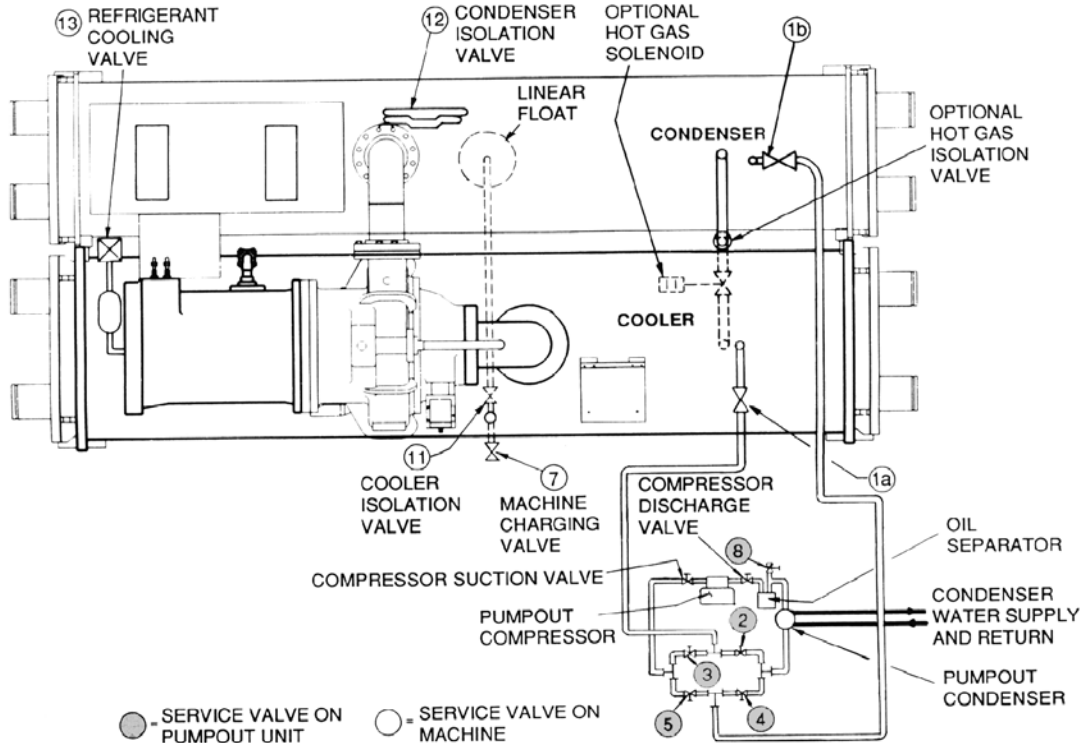
**Figure 26 — 19XL Leak Test Procedures**





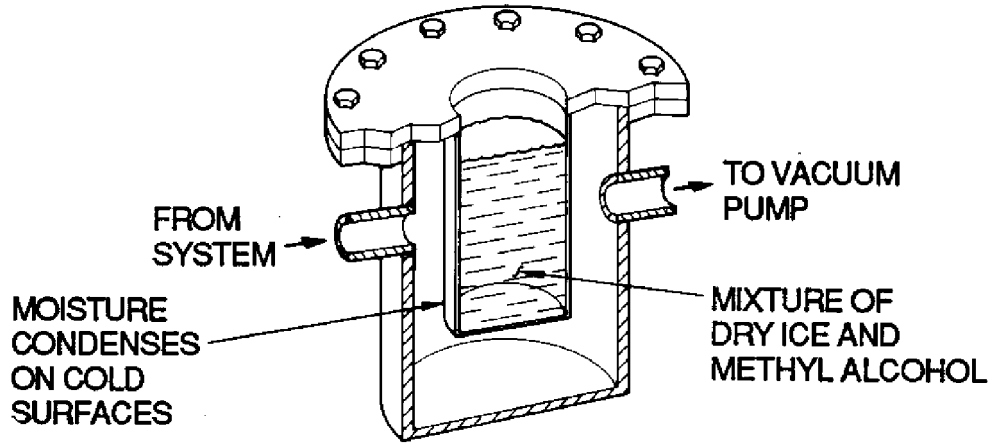
**Figure 27 — Typical Optional Pumpout System Piping Schematic with Storage Tank**





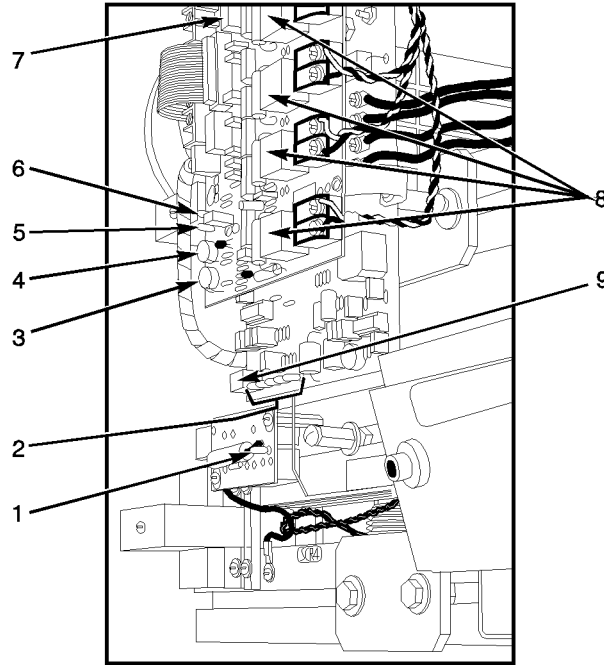
**Figure 28 — Typical Optional Pumpout System Piping Schematic without Storage Tank**





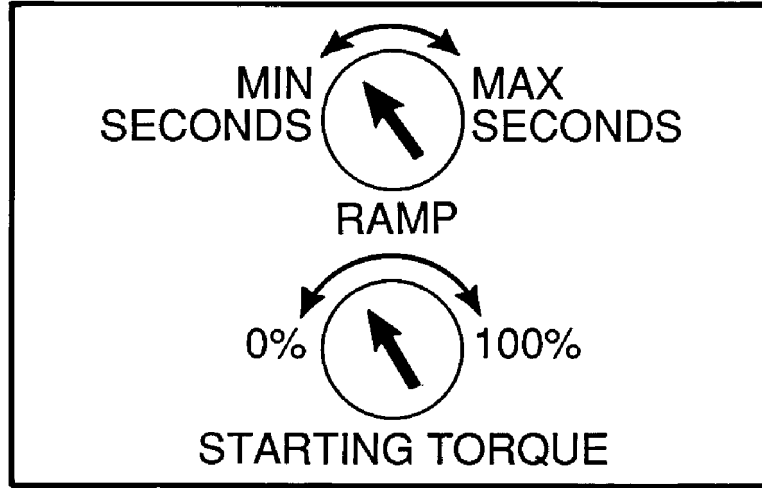
**Figure 29 — Dehydration Cold Trap**





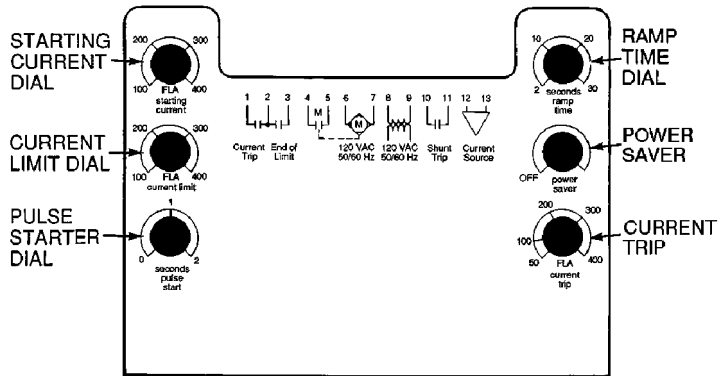
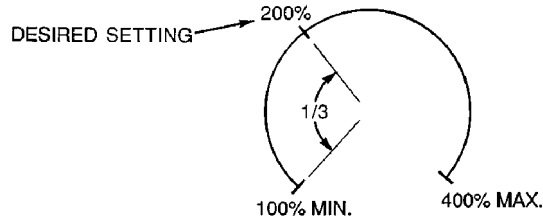
**Figure 30 — Benshaw, Inc. Solid-State Starter Power Stack**





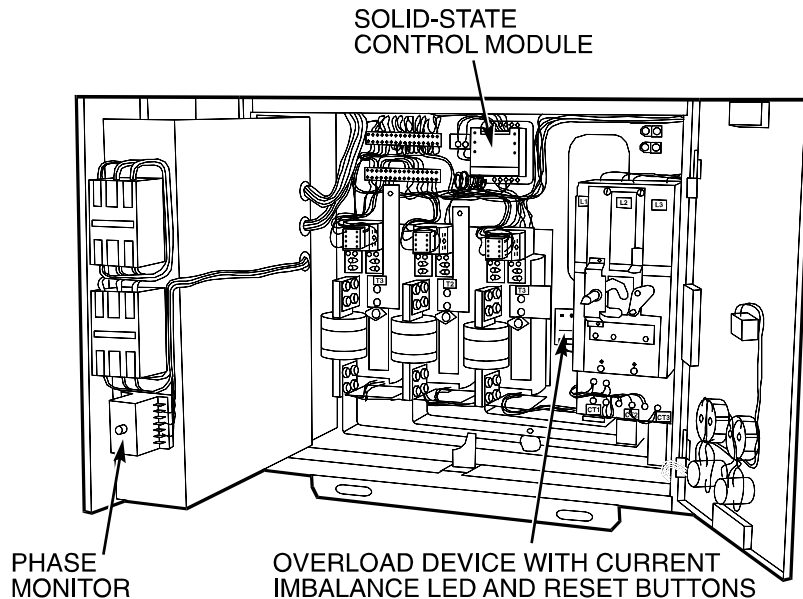
**Figure 31 — Ramp Up and Starting Torque Potentiometers**





**Figure 32 — Typical Potentiometer Adjustment**





**Figure 33 — Typical Cutler-Hammer® Solid-State Starter**





---

**ROTATION**

**CORRECT MOTOR ROTATION  
IS CLOCKWISE WHEN VIEWED  
THROUGH MOTOR SIGHT GLASS**

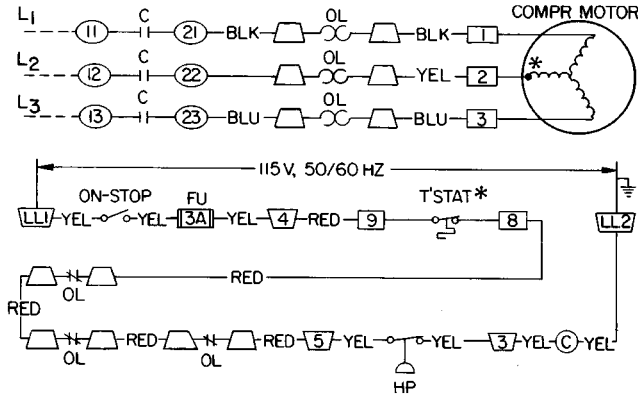
**TO CHECK ROTATION, ENERGIZE COMPRESSOR MOTOR MOMENTARILY.  
DO NOT LET MACHINE DEVELOP CONDENSER PRESSURE.  
CHECK ROTATION IMMEDIATELY.**





**ALLOWING CONDENSER PRESSURE TO BUILD OR CHECKING  
ROTATION WHILE MACHINE COASTS DOWN MAY GIVE A FALSE  
INDICATION DUE TO GAS PRESSURE EQUALIZING THROUGH COMPRESSOR.**

**Figure 34 — Correct Motor Rotation**



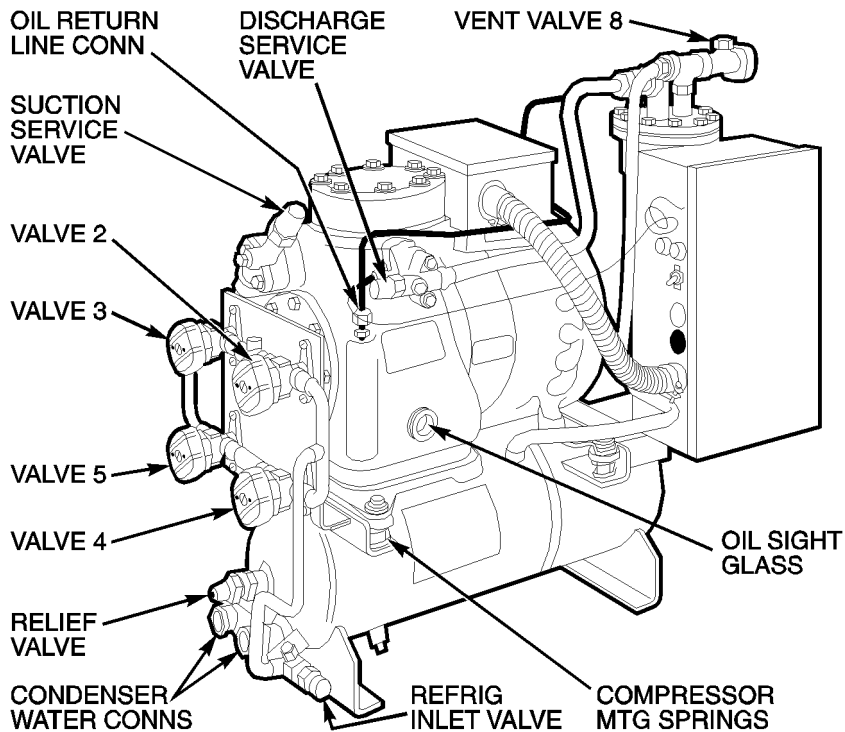




- |                                     |   |
|-------------------------------------|---|
| <b>C</b> — Contactor                |  Compressor Terminal   |
| <b>Fu</b> — Fuse, 3 Amps            |  Contactor Terminal    |
| <b>HP</b> — High-Pressure Cutout    |  Overload Terminal     |
| <b>OL</b> — Compressor Overload     |  Pumpout Unit Terminal |
| <b>T'stat</b> — Internal Thermostat |   |

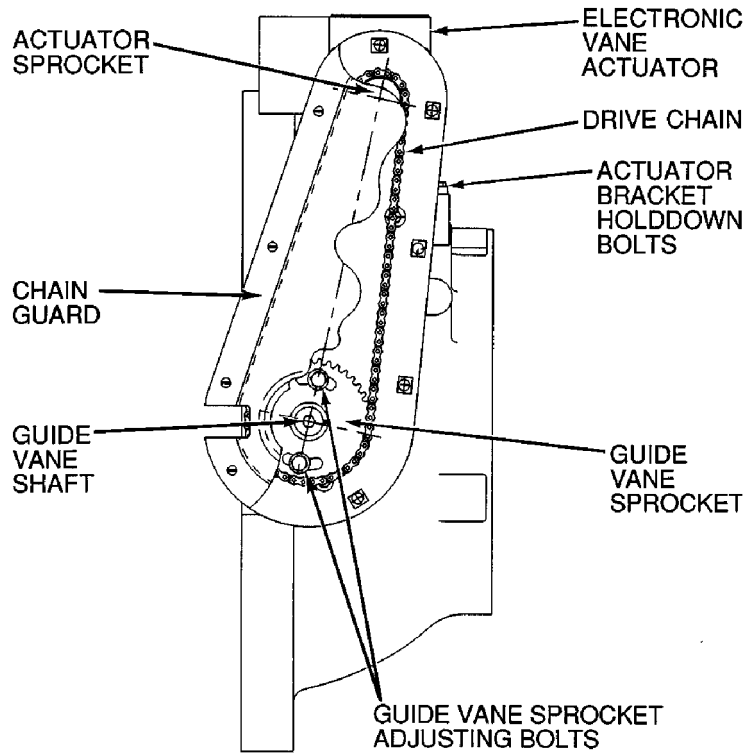
**Figure 36 — 19XL Pumpout Unit Wiring Schematic**





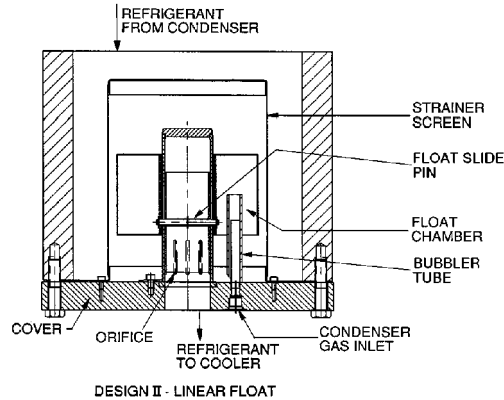
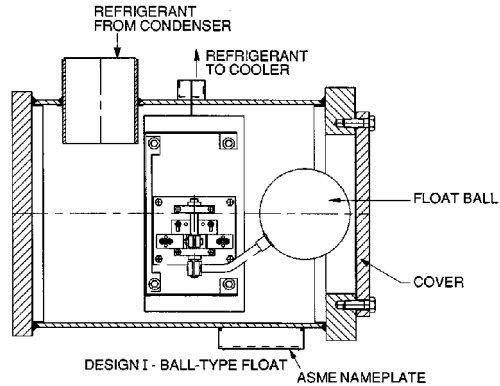
**Figure 37 — Optional Pumpout System**





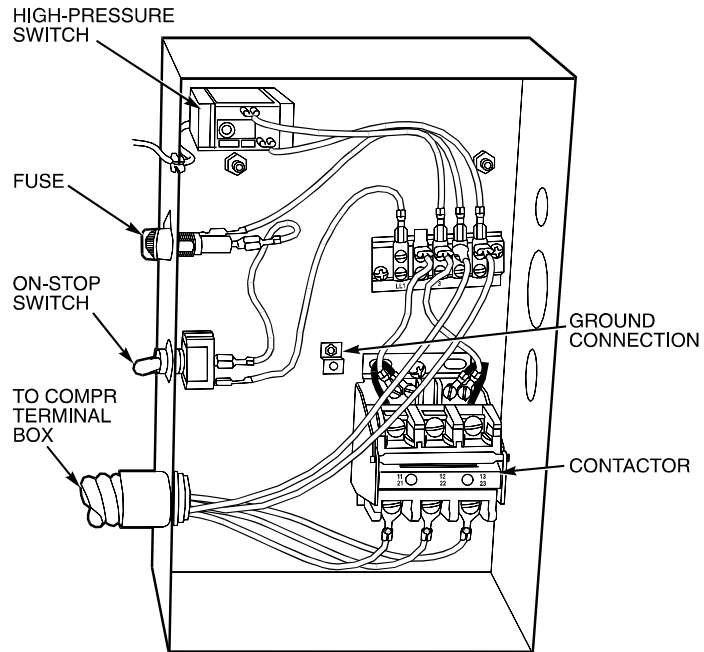
**Figure 38 — Guide Vane Actuator Linkage**





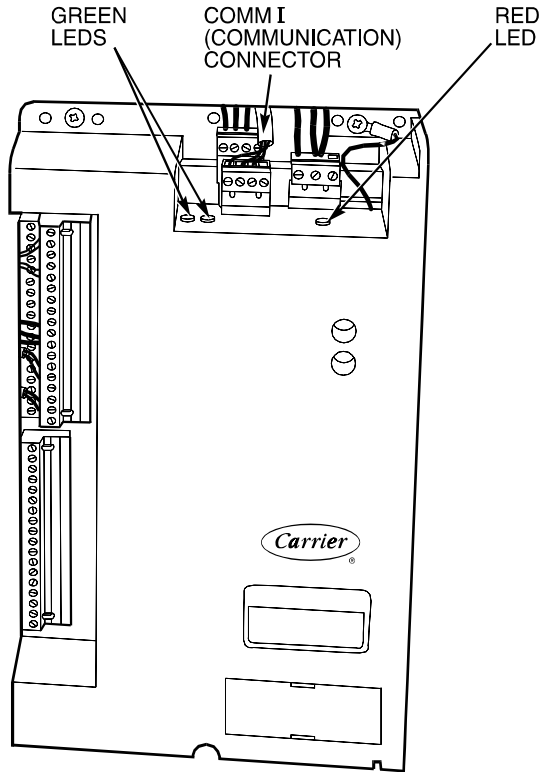
**Figure 39 — 19XL Float Valve Designs**





**Figure 40 — Optional Pumpout System Controls**

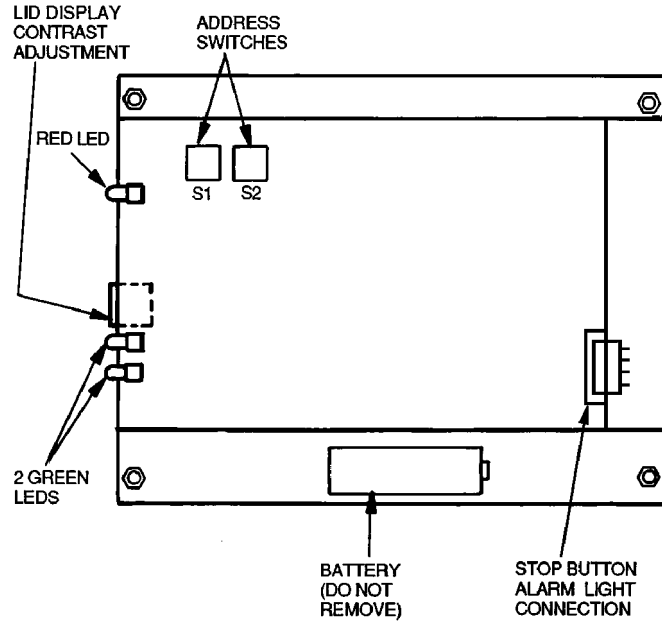




**Figure 41 — PSIO Module Address Selector Switch Locations and LED Locations**

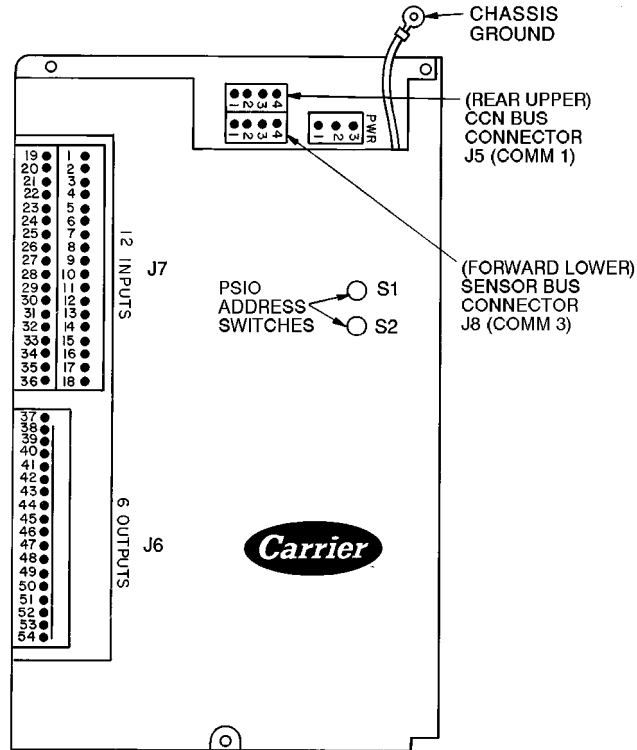






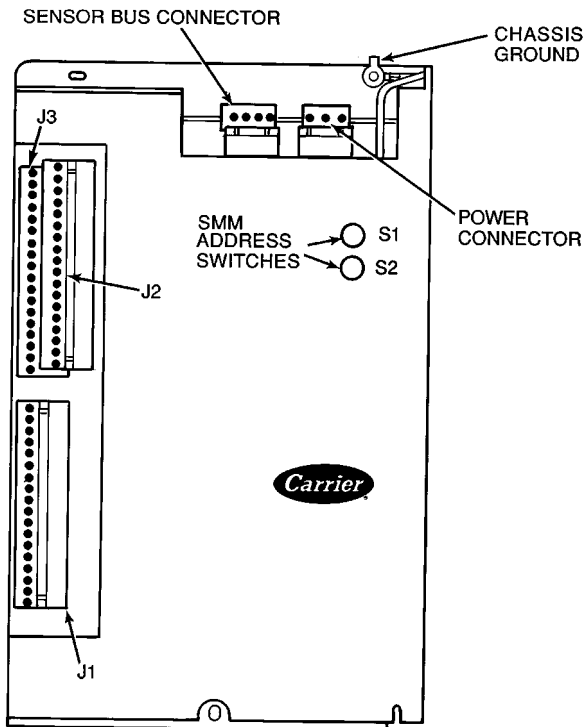
**Figure 42 — LID Module (Rear View)  
and LED Locations**





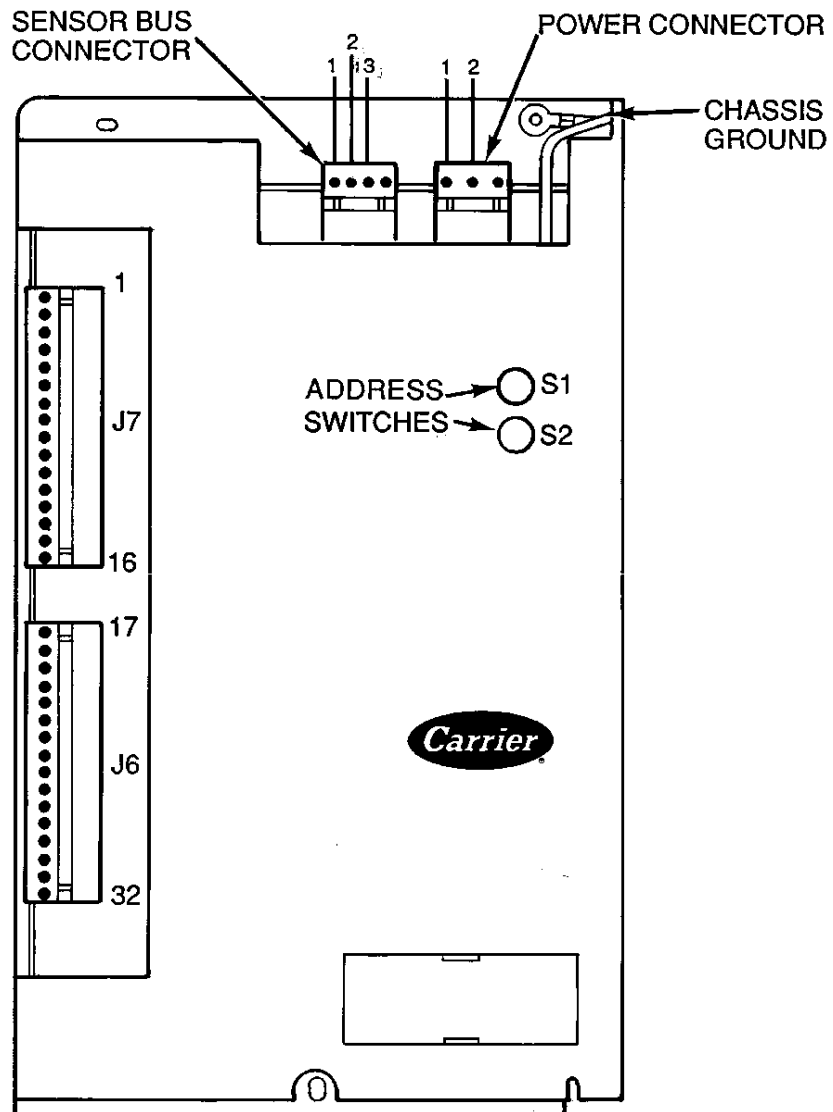
**Figure 43 — Processor (PSIO) Module**





**Figure 44 — Starter Management Module (SSM)**

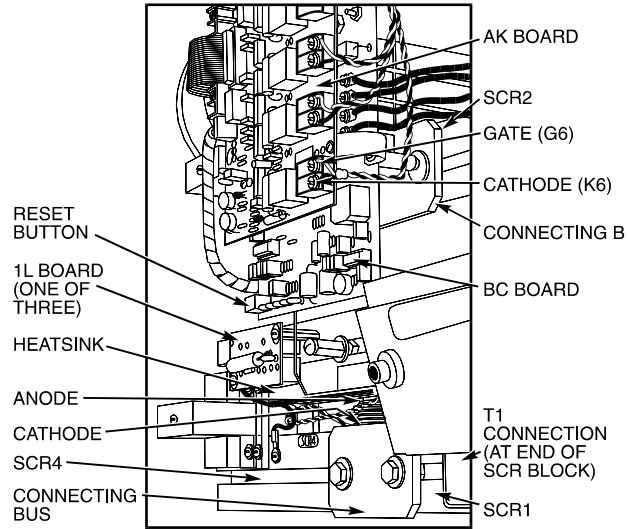




Switch Setting	Option Module 1	Option Module 2
S1	6	7
S2	4	2

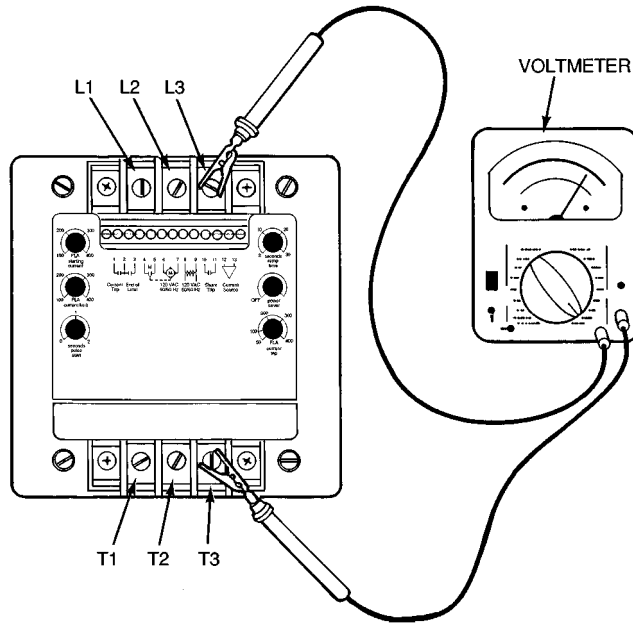
**Figure 45 — Options Module**





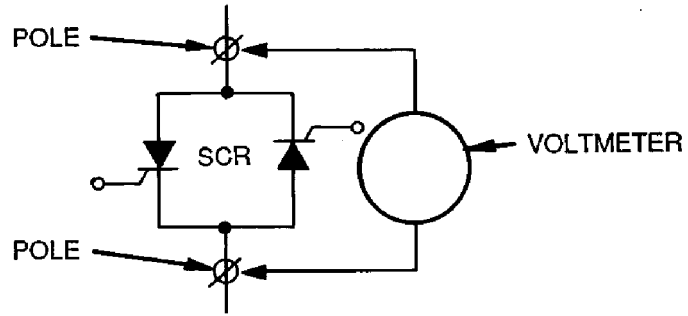
**Figure 46 — Typical Benshaw, Inc.  
Solid-State Starter (Internal View)**





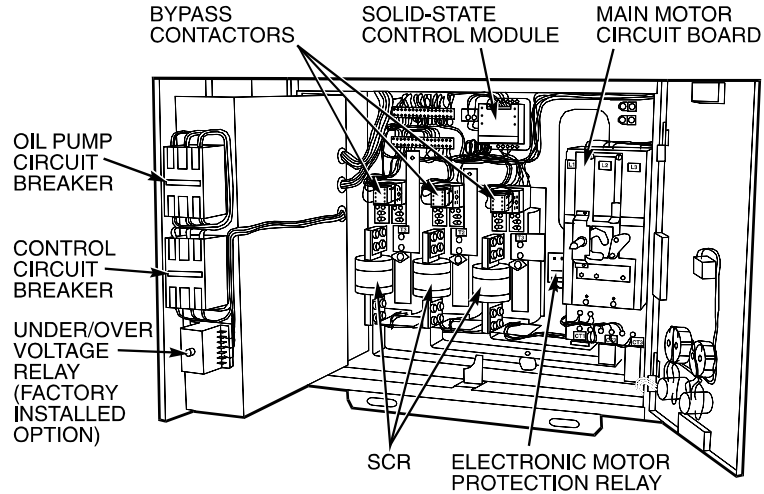
**Figure 47 — Resistance Check**





**Figure 48 — SCR and Power Poles**

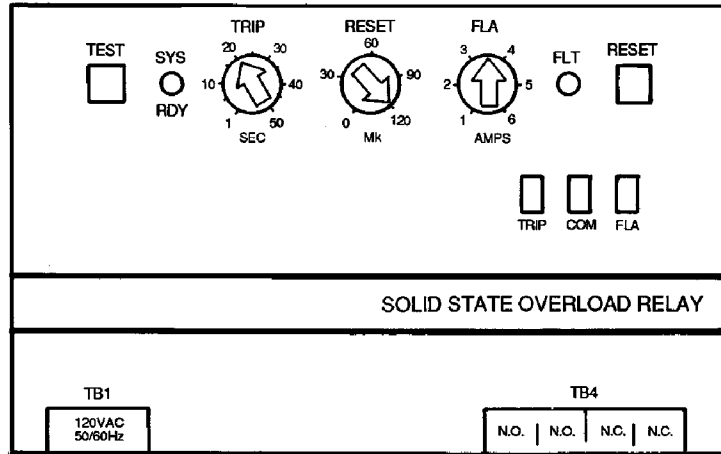




**Figure 49 — Typical Cutler-Hammer® Solid-State Starter (Internal View)**

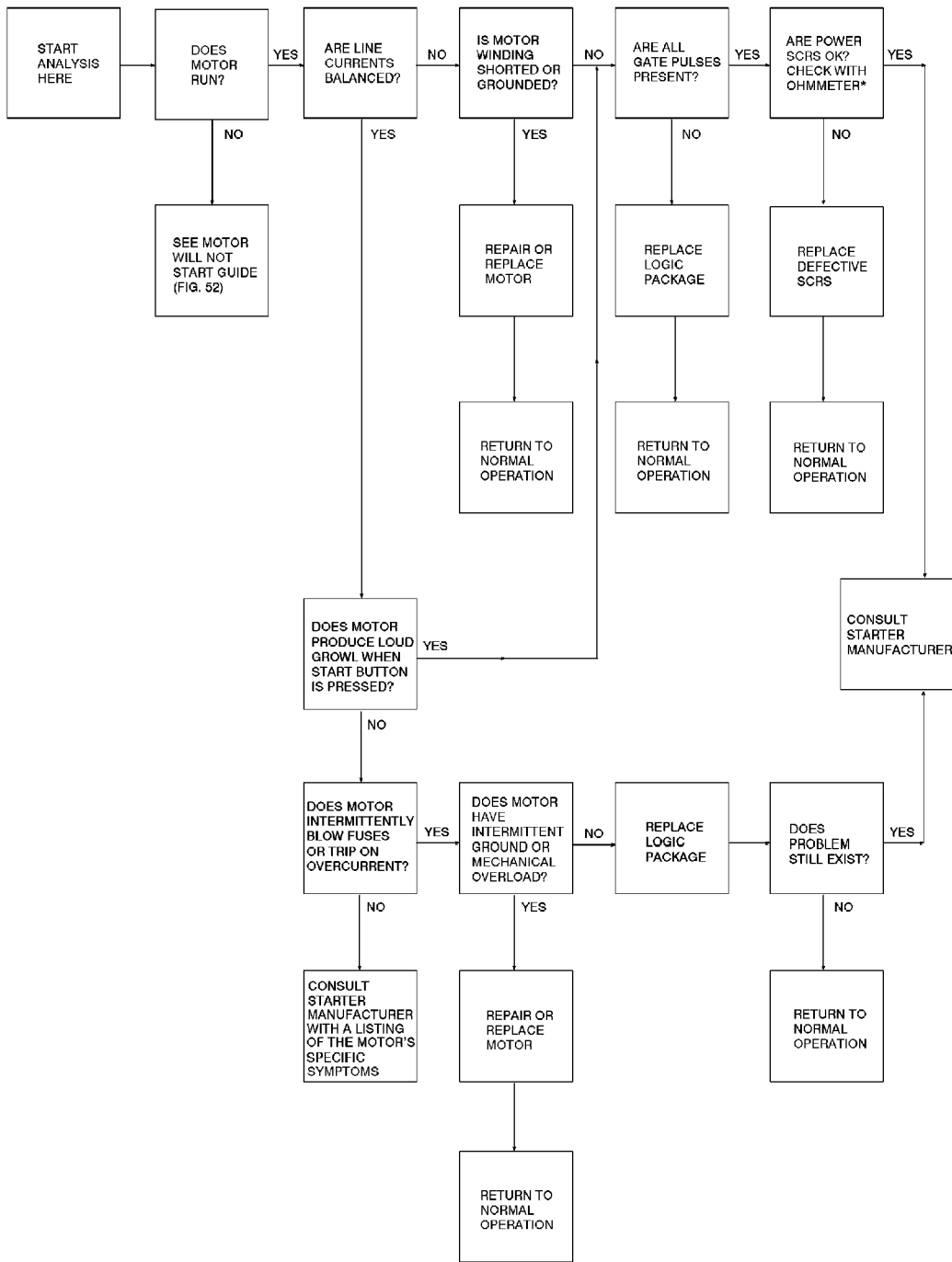






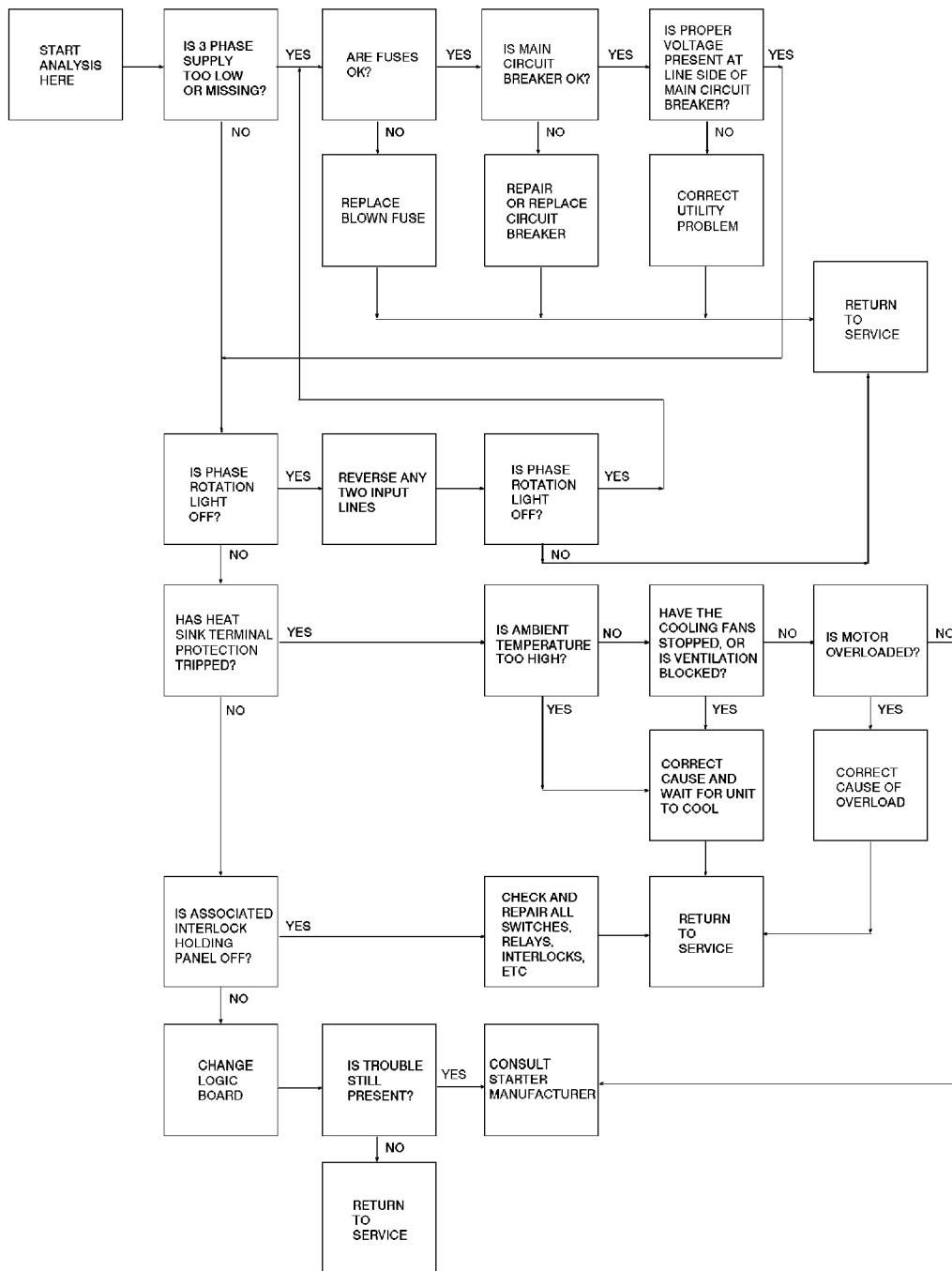
**Figure 50 — Cutler-Hammer® Terminal Functions**





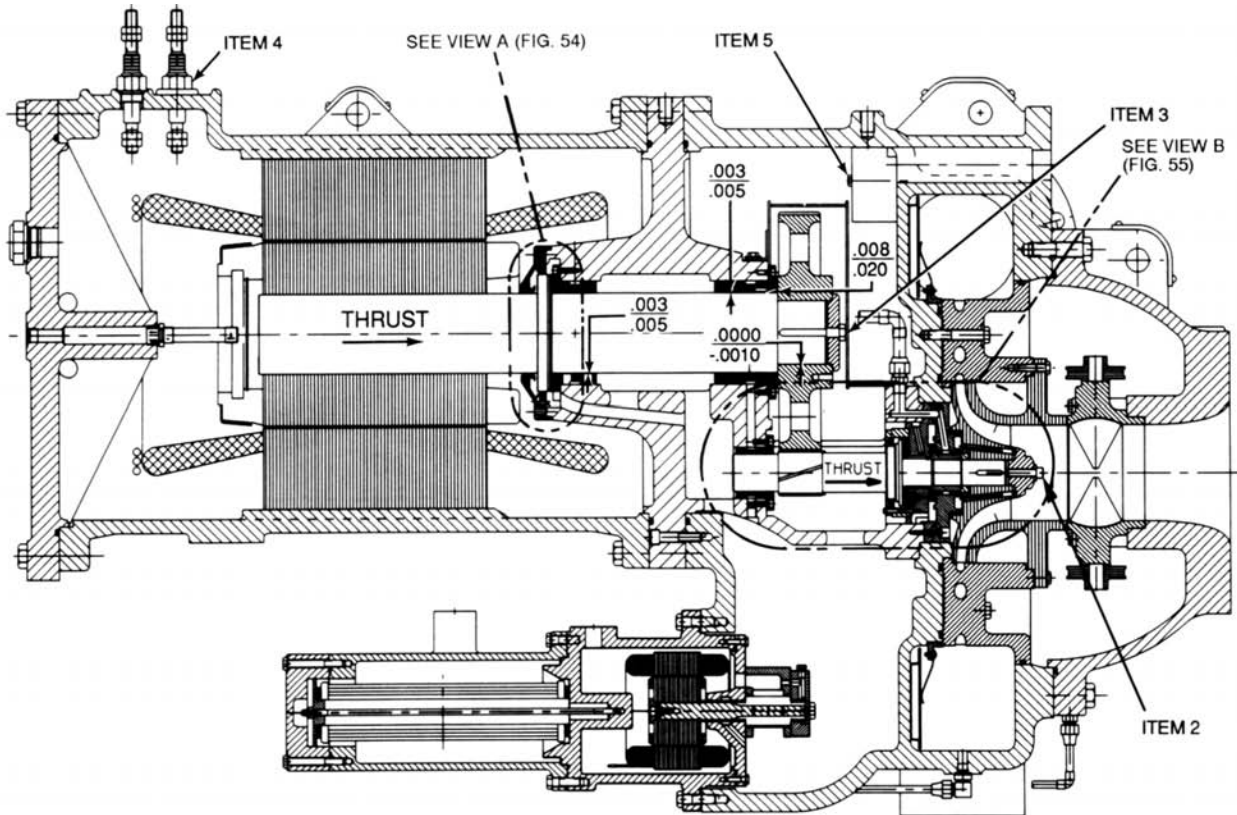
**Figure 51 — Solid-State Starter, General Operation Troubleshooting Guide (Typical)**





**Figure 52 — Solid-State Starter, Starter Fault (Motor Will Not Start) Troubleshooting Guide (Typical)**



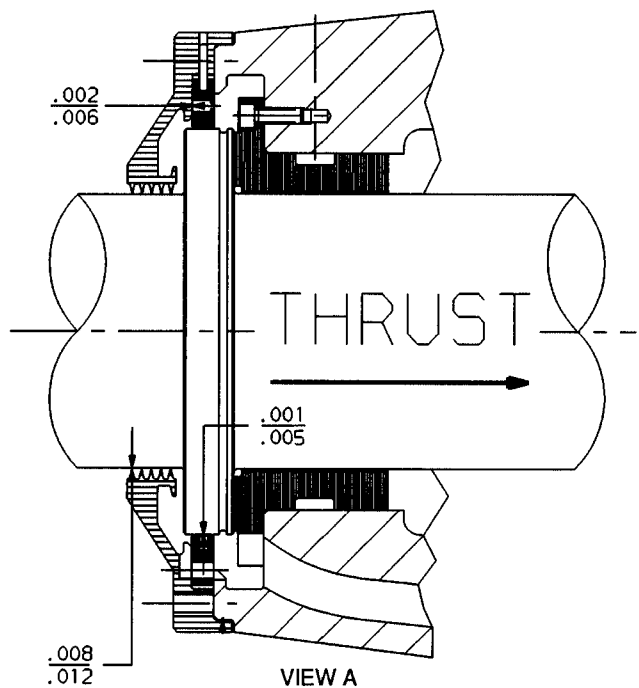


## Compressor Assembly Torques

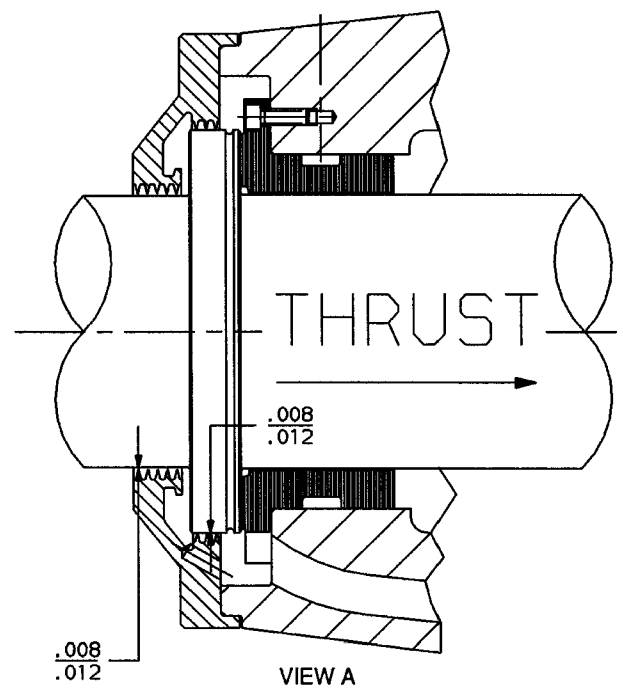
Item	Description	Torque	
		ft-lb	N•m
1*	Oil Heater Grommet Nut	10	14
2	Impeller Retaining Bolt	44-46	60-62
3	Bull Gear Retaining Bolt	80-85	108-115
4	Motor Terminals (Low Voltage)	50	68
5	Demister Bolts	15-19	20-26
6*	Guide Vane Shaft Seal Nut	25	34
7*	Motor Terminals (High Voltage)		
	– Insulator	2-4	2.7-5.4
	– Packing Nut	5	6.8
	– Brass Jam Nut	10	13.6

Figure 53 — Compressor Fits and Clearances





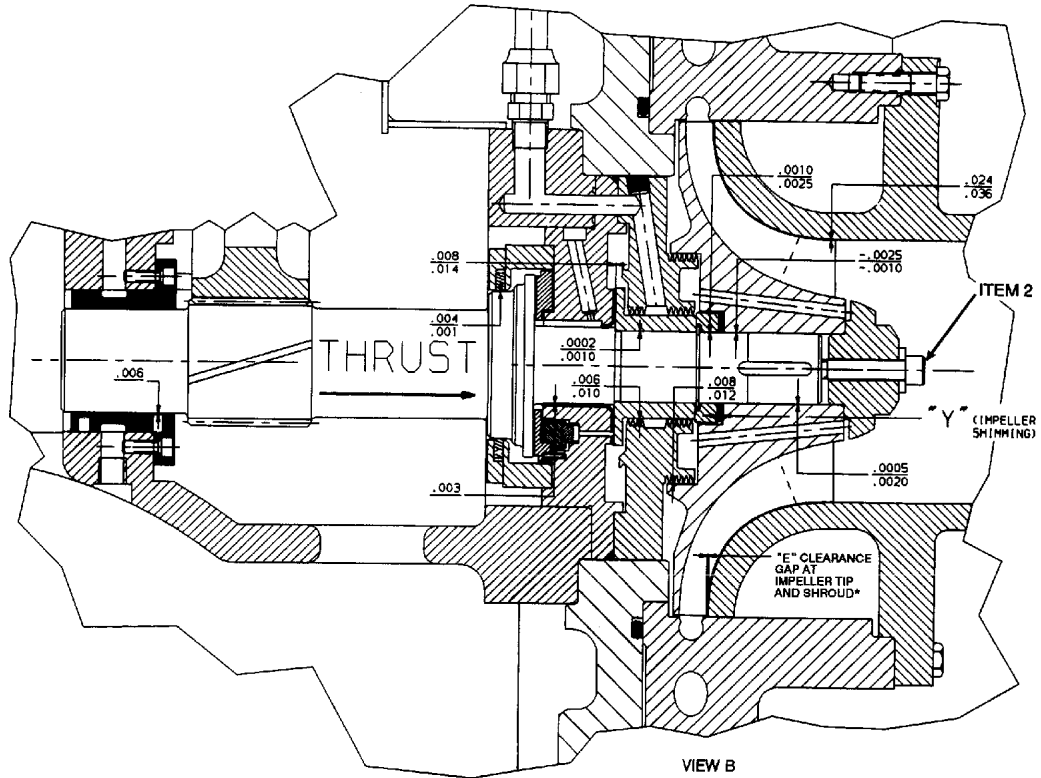
DESIGN I MOTOR REAR LABYRINTH



DESIGN II MOTOR REAR LABYRINTH

### Figure 54 — Compressor Fits and Clearances (Continued)





**Figure 55 — Compressor Fits and Clearances (Continued)**



Legend

- Carrier Factory Wiring
- - - Optional (Factory or Field-Installed) Wiring

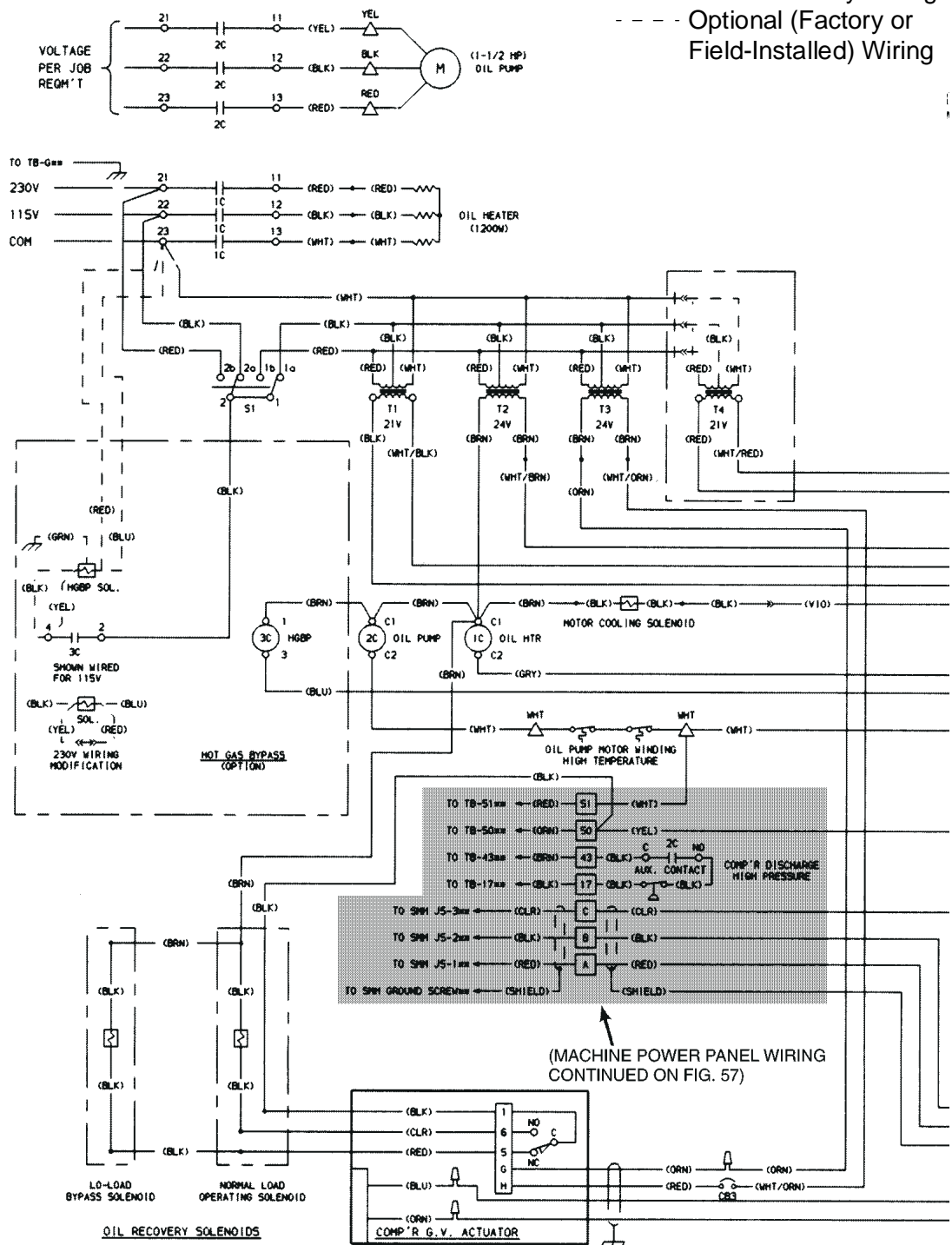
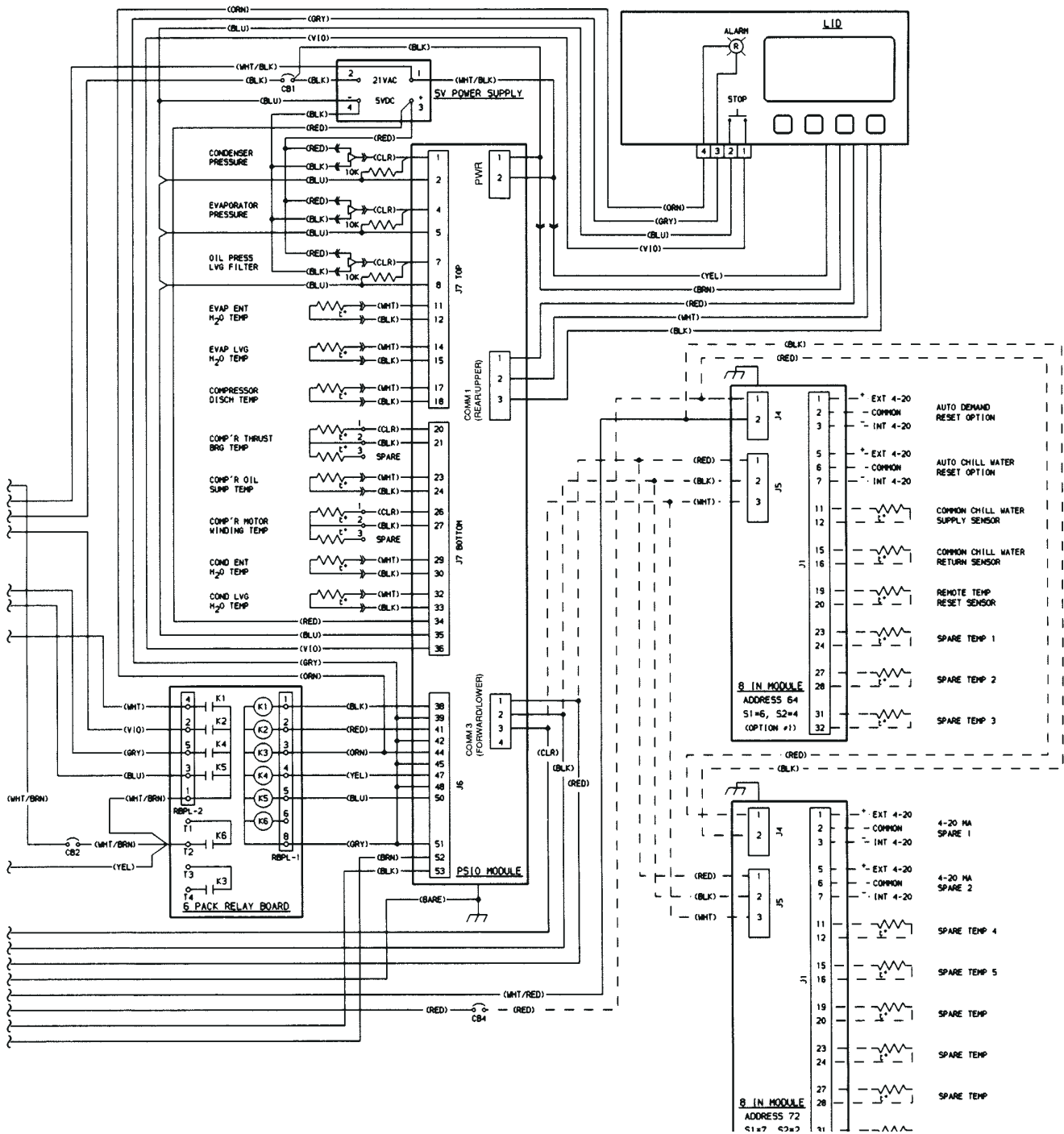


Figure 56 — Electronic PIC Controls Wiring Schematic (page 1 of 2)





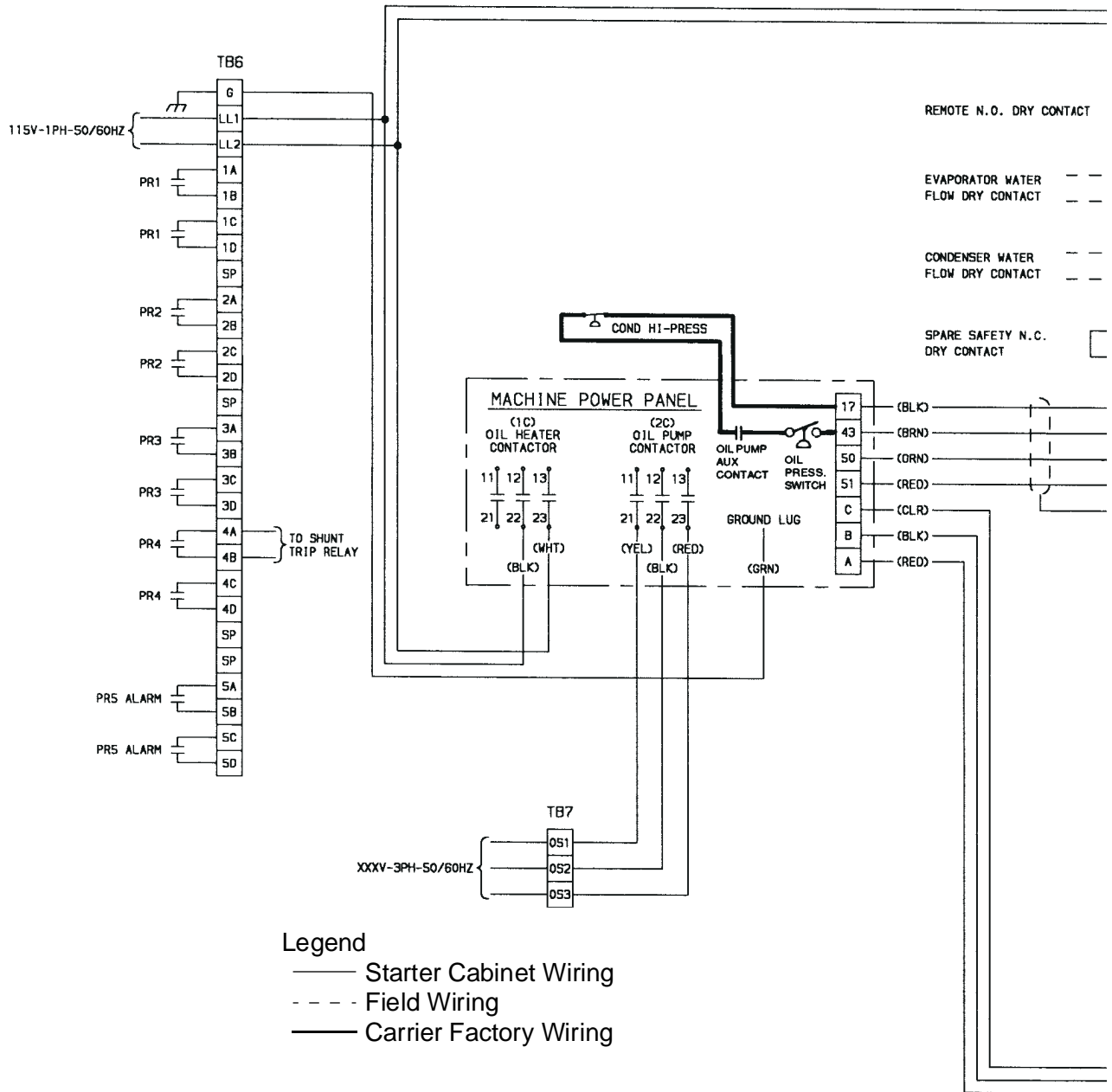
**Legend**

- Carrier Factory Wiring
- - - Optional (Factory or Field-Installed) Wiring

**Figure 56 — Electronic PIC Controls Wiring Schematic (page 2 of 2)**

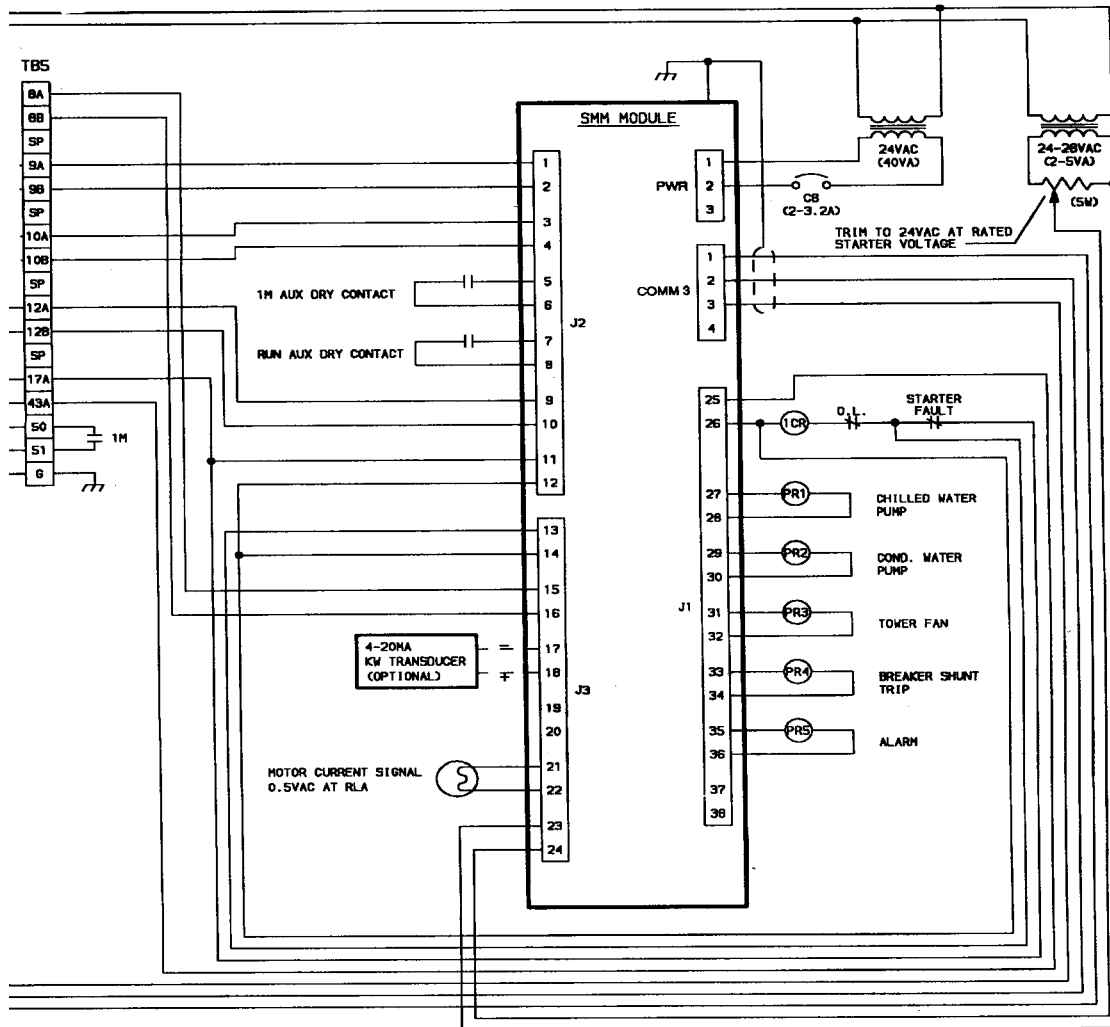






**Figure 57 — Machine Power Panel, Starter Assembly, and Motor Wiring Schematic (page 1 of 2)**



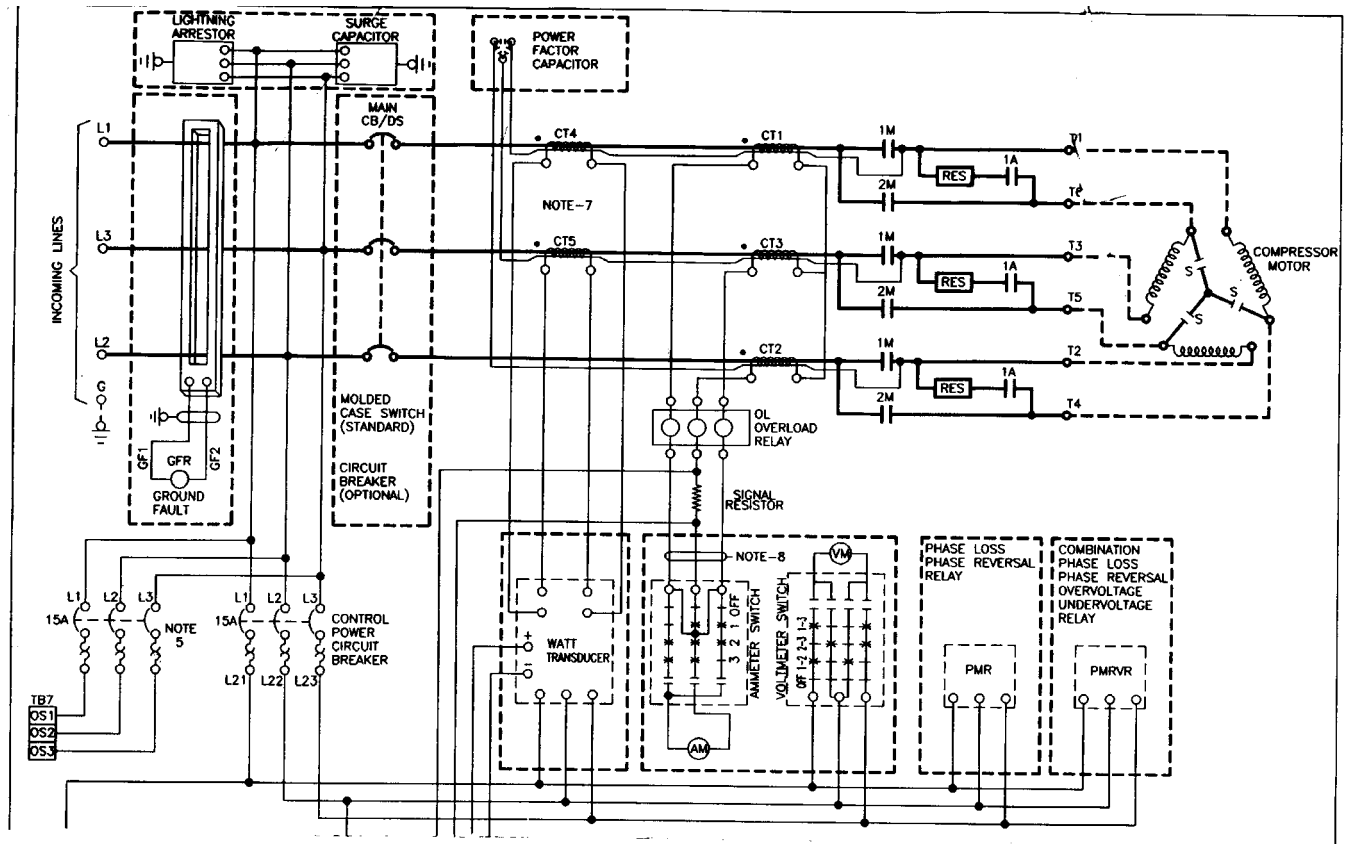


### Legend

- Starter Cabinet Wiring
- - - Field Wiring
- Carrier Factory Wiring

**Figure 57 — Machine Power Panel, Starter Assembly, and Motor Wiring Schematic (page 2 of 2)**





Optional features are indicated by bold dotted boxes.

Caution: Yellow wires remain energized when main disconnect is off.


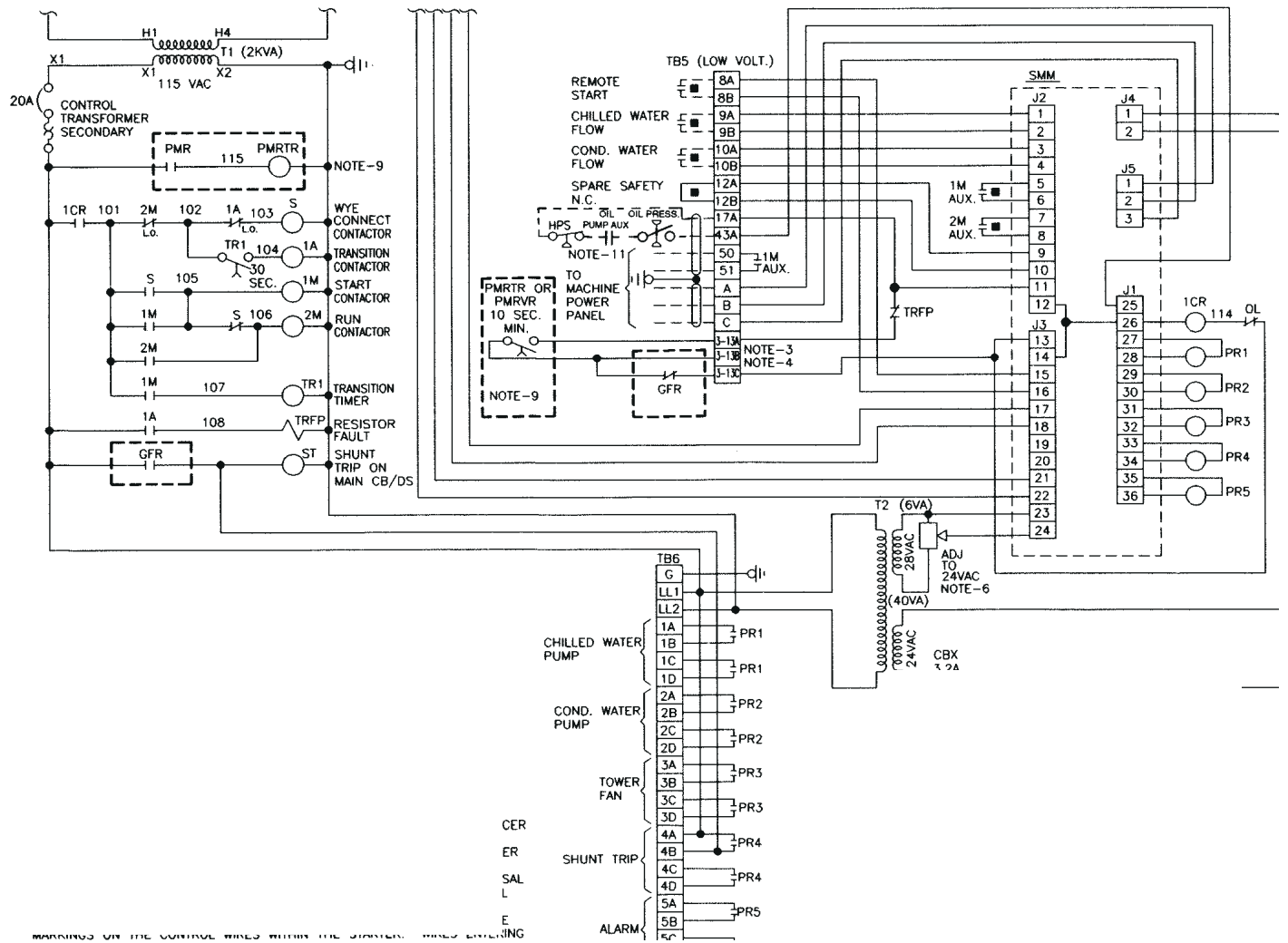
 = Dry Contact

Figure 58 — Typical Wye-Delta Unit Mounted Starter Wiring Schematic (page 1 of 2)





Optional features are indicated by bold dotted boxes.

Caution: Yellow wires remain energized when main disconnect is off.

= Dry contact

Figure 58 — Typical Wye-Delta Unit Mounted Starter Wiring Schematic (page 2 of 2)





# INITIAL START-UP CHECKLIST FOR 19XL HERMETIC CENTRIFUGAL LIQUID CHILLER (Remove and use for job file.)



### MACHINE INFORMATION:

NAME \_\_\_\_\_ JOB NO. \_\_\_\_\_  
 ADDRESS \_\_\_\_\_ MODEL \_\_\_\_\_  
 CITY \_\_\_\_\_ STATE \_\_\_\_\_ ZIP \_\_\_\_\_ S/N \_\_\_\_\_

### DESIGN CONDITIONS:

	TONS	BRINE	FLOW RATE	TEMPERATURE IN	TEMPERATURE OUT	PRESSURE DROP	PASS	SUCTION TEMPERATURE	CONDENSER TEMPERATURE
COOLER									*****
CONDENSER								*****	

COMPRESSOR: Volts \_\_\_\_\_ RLA \_\_\_\_\_ OLTA \_\_\_\_\_

STARTER: Mfg \_\_\_\_\_ Type \_\_\_\_\_

OIL PUMP: Volts \_\_\_\_\_ RLA \_\_\_\_\_ OLTA \_\_\_\_\_

CONTROL/OIL HEATER: Volts  115  230

REFRIGERANT: Type: \_\_\_\_\_ Charge \_\_\_\_\_

CARRIER OBLIGATIONS:

Assemble .....	Yes <input type="checkbox"/>	No <input type="checkbox"/>
Leak Test .....	Yes <input type="checkbox"/>	No <input type="checkbox"/>
Dehydrate .....	Yes <input type="checkbox"/>	No <input type="checkbox"/>
Charging .....	Yes <input type="checkbox"/>	No <input type="checkbox"/>
Operating Instructions _____	Hrs.	

### START-UP TO BE PERFORMED IN ACCORDANCE WITH APPROPRIATE MACHINE START-UP INSTRUCTIONS

#### JOB DATA REQUIRED:

1. Machine Installation Instructions ..... Yes  No
2. Machine Assembly, Wiring and Piping Diagrams ..... Yes  No
3. Starting Equipment Details and Wiring Diagrams ..... Yes  No
4. Applicable Design Data (see above) ..... Yes  No
5. Diagrams and Instructions for Special Controls ..... Yes  No

INITIAL MACHINE PRESSURE: \_\_\_\_\_

	YES	NO
Was Machine Tight?		
If Not, Were Leaks Corrected?		
Was Machine Dehydrated After Repairs?		

CHECK OIL LEVEL AND RECORD: A 

E	□	□	□	□	□	□	□	□	□	□	□
---	---	---	---	---	---	---	---	---	---	---	---

 F

B 

E	□	□	□	□	□	□	□	□	□	□	□
---	---	---	---	---	---	---	---	---	---	---	---

 F

ADD OIL: Yes  No

Amount: \_\_\_\_\_

RECORD PRESSURE DROPS: Cooler \_\_\_\_\_ Condenser \_\_\_\_\_

CHARGE REFRIGERANT: Initial Charge \_\_\_\_\_ Final Charge After Trim \_\_\_\_\_

INSPECT WIRING AND RECORD ELECTRICAL DATA:

RATINGS:

Motor Voltage \_\_\_\_\_ Motor(s) Amps \_\_\_\_\_ Oil Pump Voltage \_\_\_\_\_ Starter Amps \_\_\_\_\_  
 Line Voltages: Motor \_\_\_\_\_ Oil Pump \_\_\_\_\_ Controls/Oil Heater \_\_\_\_\_

FIELD-INSTALLED STARTERS ONLY:

Check continuity T1 to T1, etc. (Motor to starter, disconnect motor leads T4, T5, T6.) Do not megger solid-state starters, disconnect leads to motor and megger the leads.

MEGGER MOTOR	"PHASE TO PHASE"			"PHASE TO GROUND"		
	T1-T2	T1-T3	T2-T3	T1-G	T2-G	T3-G
10-Second Readings:						
60-Second Readings:						
Polarization Ratio:						

STARTER: Electro-Mechanical  Solid-State  Manufacturer \_\_\_\_\_  
 Serial Number \_\_\_\_\_

Motor Load Current Transformer Ratio \_\_\_\_\_ : \_\_\_\_\_ Signal Resistor Size \_\_\_\_\_ Ohms

Transition Timer Time \_\_\_\_\_ Seconds

Check Magnetic Overloads Add Dash Pot Oil Yes  No  Solid-State Overloads Yes  No

Solid State Starter: Torque Setting \_\_\_\_\_ O'Clock Ramp Setting \_\_\_\_\_ Seconds

CONTROLS: SAFETY, OPERATING, ETC.

Perform Controls Test (Yes/No) \_\_\_\_\_

<b>PIC CAUTION</b>	Yes _____
COMPRESSOR MOTOR AND CONTROL CENTER <b>MUST</b> BE PROPERLY AND INDIVIDUALLY CONNECTED BACK TO THE EARTH GROUND IN THE STARTER. (IN ACCORDANCE WITH CERTIFIED DRAWINGS).	

RUN MACHINE: Do these safeties shut down machine?

Condenser Water Flow Switch Yes  No   
 Chilled Water Flow Switch Yes  No   
 Pump Interlocks Yes  No

INITIAL START:

Line Up All Valves in Accordance With Instruction Manual: \_\_\_\_\_ Start Water Pumps and Establish Water Flow \_\_\_\_\_

Oil Level OK and Oil Temperature OK \_\_\_\_\_ Check Oil Pump Rotation-Pressure \_\_\_\_\_

Check Compressor Motor Rotation (Motor End Sight Glass) and Record: Clockwise \_\_\_\_\_

Restart Compressor, Bring Up To Speed. Shut Down. Any Abnormal Coastdown Noise? Yes\*  No

\*If yes, determine cause.

START MACHINE AND OPERATE. COMPLETE THE FOLLOWING:

- A: Trim Charge and Record Under Charge Refrigerant Section on page 51.
- B: Complete Any Remaining Control Calibration and Record Under Controls Section (pages 11-36).
- C: Take At Least 2 Sets of Operational Log Readings and Record.
- E: After Machine Has Been Successfully Run and Set Up, Shut Down and Mark Shutdown Oil and Refrigerant Levels.
- F: Give Operating Instructions to Owner's Operating Personnel. Hours Given: \_\_\_\_\_ Hours
- G: Call your Carrier factory representative to report chiller start-up.

SIGNATURES: \_\_\_\_\_ DATE \_\_\_\_\_

CARRIER \_\_\_\_\_ CUSTOMER REPRESENTATIVE \_\_\_\_\_  
 TECHNICIAN \_\_\_\_\_ DATE \_\_\_\_\_



**19XL  
HERMETIC CENTRIFUGAL LIQUID CHILLER  
CONFIGURATION SETTINGS LOG  
(Remove and use for job file.)**

<b>19XL SET POINT TABLE CONFIGURATION SHEET</b>				
DESCRIPTION	RANGE	UNITS	DEFAULT	VALUE
<b>Base Demand Limit</b>	40 to 100	%	100.0	
<b>LCW Setpoint</b>	20 to 120 (-6.7 to 48.9)	DEG F (DEG C)	50.0	
<b>ECW Setpoint</b>	20 to 120 (-6.7 to 48.9)	DEG F (DEG C)	60.0	
<b>ICE BUILD Setpoint</b>	20 to 60 (-6.7 to 15.6)	DEG F (DEG C)	40.0	

PSIO Software Version Number: \_\_\_\_\_

LID Software Version Number: \_\_\_\_\_

PSIO Controller Identification: BUS \_\_\_\_\_ ADDRESS \_\_\_\_\_

LID Identification: BUS \_\_\_\_\_ ADDRESS \_\_\_\_\_



19XL PIC TIME SCHEDULE CONFIGURATION SHEET OCCPC01S

	Day Flag								Occupied Time				Unoccupied Time			
	M	T	W	T	F	S	S	H								
Period 1:																
Period 2:																
Period 3:																
Period 4:																
Period 5:																
Period 6:																
Period 7:																
Period 8:																

NOTE: Default setting is OCCUPIED 24 hours/day.

ICE BUILD 19XL PIC TIME SCHEDULE CONFIGURATION SHEET OCCPC02S

	Day Flag								Occupied Time				Unoccupied Time			
	M	T	W	T	F	S	S	H								
Period 1:																
Period 2:																
Period 3:																
Period 4:																
Period 5:																
Period 6:																
Period 7:																
Period 8:																

NOTE: Default setting is UNOCCUPIED 24 hours/day.

19XL PIC TIME SCHEDULE CONFIGURATION SHEET OCCPC\_\_ S

	Day Flag								Occupied Time				Unoccupied Time			
	M	T	W	T	F	S	S	H								
Period 1:																
Period 2:																
Period 3:																
Period 4:																
Period 5:																
Period 6:																
Period 7:																
Period 8:																

NOTE: Default setting is OCCUPIED 24 hours/day.



19XL PIC CONFIG TABLE CONFIGURATION SHEET				
DESCRIPTION	RANGE	UNITS	DEFAULT	VALUE
<b>RESET TYPE 1</b>				
<b>Degrees Reset at 20 mA</b>	-30 to 30 (-17 to 17)	DEG F (DEG C)	10 (6)	
<b>RESET TYPE 2</b>				
<b>Remote Temp (No Reset)</b>	-40 to 245 (-40 to 118)	DEG F (DEG C)	85 (29)	
<b>Remote Temp (Full Reset)</b>	-40 to 245 (-40 to 118)	DEG F (DEG C)	65 (18)	
<b>Degrees Reset</b>	-30 to 30 (-17 to 17)	DEG F (DEG C)	10 (6)	
<b>RESET TYPE 3</b>				
<b>CHW Temp (No Reset)</b>	0 to 15 (0 to 8)	DEG F (DEG C)	10 (6)	
<b>CHW Temp (Full Reset)</b>	0 to 15 (0 to 8)	DEG F (DEG C)	0 (0)	
<b>Degrees Reset</b>	-30 to 30 (-17 to 17)	DEG F (DEG C)	5 (3)	
<b>Select/Enable Reset Type</b>	0 to 3		0	
<b>ECW Control Option</b>	Disable/Enable		Disable	
<b>Demand Limit at 20 mA</b>	40 to 100	%	40	
<b>20 mA Demand Limit Option</b>	Disable/Enable		Disable	
<b>Auto Restart Option</b>	Disable/Enable		Disable	
<b>Remote Contacts Option</b>	Disable/Enable		Disable	
<b>Temp Pulldown Deg/Min</b>	2 to 10		3	
<b>Load Pulldown %/Min</b>	5 to 20		10	
<b>Select Ramp Type: Temp=0/Load=1</b>	0/1		1	
<b>Loadshed Group Number</b>	0 to 99		0	
<b>Loadshed Demand Delta</b>	0 to 60	%	20	
<b>Maximum Loadshed Time</b>	0 to 120	Min	60	
<b>CCN Occupancy Config: Schedule Number</b>	3 to 99		3	
<b>CCN Occupancy Config: Broadcast Option</b>	Disable/Enable		Disable	
<b>ICE BUILD Option</b>	Disable/Enable		Disable	
<b>ICE BUILD TERMINATION: 0 =Temp, 1 =Contacts, 2 =Both</b>	0, 1, 2		0	
<b>ICE BUILD RECYCLE Option</b>	Disable/Enable		Disable	

19XL PIC LEAD/LAG TABLE CONFIGURATION SHEET				
DESCRIPTION	RANGE	UNITS	DEFAULT	VALUE
<b>LEAD/LAG SELECT</b> DISABLE =0, LEAD =1, LAG =2, STANDBY =3	0, 1, 2, 3		0	
<b>Load Balance Option</b>	Disable/Enable		Disable	
<b>Common Sensor Option</b>	Disable/Enable		Disable	
<b>LAG Percent Capacity</b>	25 to 75	%	50	
<b>LAG Address</b>	1 to 236		92	
<b>LAG START Timer</b>	2 to 60	Min	10	
<b>LAG STOP Timer</b>	2 to 60	Min	10	
<b>PRESTART FAULT Timer</b>	0 to 30	Min	5	
<b>STANDBY Chiller Option</b>	Disable/Enable		Disable	
<b>STANDBY Percent Capacity</b>	25 to 75	%	50	
<b>STANDBY Address</b>	1 to 236		93	

19XL PIC SERVICE1 TABLE CONFIGURATION SHEET				
DESCRIPTION	RANGE	UNITS	DEFAULT	VALUE
Motor Temp Override	150 to 200 (66 to 93)	DEG F (DEG C)	200 (93)	
Cond Pressure Override	150 to 245 (1034 to 1639) [90 to 200 (620 to 1379)]	psig (kPa)	195 (1345) [125 (862)]	
Refrig Override Delta T	2 to 5 (1 to 3)	DEG F (DEG C)	3 (1.6)	
Chilled Medium	Water/Brine		Water	
Brine Refrig Trippoint	8 to 40 (-13.3 to 4)	DEG F (DEG C)	33 (1)	
Compr Discharg Alert	125 to 200 (52 to 93)	DEG F (DEG C)	200 (93)	
Bearing Temp Alert	175 to 185 (79 to 85)	DEG F (DEG C)	175 (79)	
Water Flow Verify Time	0.5 to 5	MIN	5	
Oil Press Verify Time	15 to 300	SEC	15	
Water/Brine Deadband	0.5 to 2.0 (0.3 to 1.1)	DEG F (DEG C)	1.0 (0.6)	
Recycle Restart Delta T	2.0 to 10 (1.1 to 5.5)	DEG F (DEG C)	5 (2.8)	
Surge Limit/HGBP Option Surge=0/HGBP=1	0/1		0	
Surge/HGBP Delta T1	0.5 to 15 (0.3 to 8.3)	DEG F (DEG C)	1.5 (0.8)	
Surge/HGBP Delta P1	50 to 170 (345 to 1172) [30 to 170 (206 to 1172)]	psi (kPa)	75 (517) [50 (345)]	
Surge/HGBP Delta T2	0.5 to 15.0 (0.3 to 8.3)	DEG F (DEG C)	10 (5.6)	
Surge/HGBP Delta P2	50 to 170 (345 to 1172) [30 to 170 (206 to 1172)]	psi (kPa)	170 (1172) [85 (586)]	
Surge/HGBP Deadband	1 to 3 (0.6 to 1.6)	DEG F (DEG C)	1 (0.6)	
Surge Delta Percent Amps	10 to 50	%	25	
Surge Time Period	1 to 5	MIN	2	
Demand Limit Source Amps=0/Load=1	0/1		0	
Amps Correction Factor	1 to 8		3	

NOTE: Values in [ ] indicate HFC-134a values, if this refrigerant is configured in the Control Test.

**19XL PIC SERVICE1 TABLE CONFIGURATION SHEET**

<b>DESCRIPTION</b>	<b>RANGE</b>	<b>UNITS</b>	<b>DEFAULT</b>	<b>VALUE</b>
<b>Motor Rated Load Amps</b>	1 to 9999	AMPS	200	
<b>Motor Rated Line Voltage</b>	1 to 9999	VOLTS	460	
<b>Meter Rated Line kW</b>	1 to 9999	kW	600	
<b>Line Frequency</b> 0=60 Hz/1=50 Hz	0/1		0	
<b>Compressor Starter Type</b>	REDUCE/FULL		REDUCE	
<b>Condenser Freeze Point</b>	-20 to 35 (-28.9 to 1.7)	DEG F (DEG C)	34 (1.1)	
<b>Soft Stop Amps Threshold</b>	40 to 100	%	100	

19XL PIC SERVICE2 TABLE CONFIGURATION SHEET				
DESCRIPTION	RANGE	UNITS	DEFAULT	VALUE
RESET 20 mA Power Source	0/1	0 =EXTERNAL, 1 =INTERNAL	0	
DEMAND 20 mA Power Source	0/1	0 =EXTERNAL, 1 =INTERNAL	0	
CHWS Temp Enable	0 to 2	0 =DISABLE, 1 =HIGH, 2 =LOW	0	
CHWS Temp Alert	-40 to 245 (-40 to 118)	DEG F (DEG C)	245 (118)	
CHWR Temp Enable	0 to 2	0 =DISABLE, 1 =HIGH, 2 =LOW	0	
CHWR Temp Alert	-40 to 245 (-40 to 118)	DEG F (DEG C)	245 (118)	
Reset Temp Enable	0 to 2	0 =DISABLE, 1 =HIGH, 2 =LOW	0	
Reset Temp Alert	-40 to 245 (-40 to 118)	DEG F (DEG C)	245 (118)	
Spare Temp 1 Enable	0 to 2	0 =DISABLE, 1 =HIGH, 2 =LOW	0	
Spare Temp 1 Alert	-40 to 245 (-40 to 118)	DEG F (DEG C)	245 (118)	
Spare Temp 2 Enable	0 to 2	0 =DISABLE, 1 =HIGH, 2 =LOW	0	
Spare Temp 2 Alert	-40 to 245 (-40 to 118)	DEG F (DEG C)	245 (118)	
Spare Temp 3 Enable	0 to 2	0 =DISABLE, 1 =HIGH, 2 =LOW	0	
Spare Temp 3 Alert	-40 to 245 (-40 to 118)	DEG F (DEG C)	245 (118)	
SPARE 1 20 mA Power Source	0/1	0 =EXTERNAL, 1 =INTERNAL	0	
SPARE 2 20 mA Power Source	0/1	0 =EXTERNAL, 1 =INTERNAL	0	
Spare Temp 4 Enable	0 to 2	0 =DISABLE, 1 =HIGH, 2 =LOW	0	
Spare Temp 4 Alert	-40 to 245 (-40 to 118)	DEG F (DEG C)	245 (118)	
Spare Temp 5 Enable	0 to 2	0 =DISABLE, 1 =HIGH, 2 =LOW	0	
Spare Temp 5 Alert	-40 to 245 (-40 to 118)	DEG F (DEG C)	245 (118)	
Spare Temp 6 Enable	0 to 2	0 =DISABLE, 1 =HIGH, 2 =LOW	0	
Spare Temp 6 Alert	-40 to 245 (-40 to 118)	DEG F (DEG C)	245 (118)	
Spare Temp 7 Enable	0 to 2	0 =DISABLE, 1 =HIGH, 2 =LOW	0	
Spare Temp 7 Alert	-40 to 245 (-40 to 118)	DEG F (DEG C)	245 (118)	
Spare Temp 8 Enable	0 to 2	0 =DISABLE, 1 =HIGH, 2 =LOW	0	
Spare Temp 8 Alert	-40 to 245 (-40 to 118)	DEG F (DEG C)	245 (118)	
Spare Temp 9 Enable	0 to 2	0 =DISABLE, 1 =HIGH, 2 =LOW	0	
Spare Temp 9 Alert	-40 to 245 (-40 to 118)	DEG F (DEG C)	245 (118)	

**19XL PIC SERVICE3 TABLE CONFIGURATION SHEET**

<b>DESCRIPTION</b>	<b>RANGE</b>	<b>UNITS</b>	<b>DEFAULT</b>	<b>VALUE</b>
<b>Proportional Inc Band</b>	2 to 10		6.5	
<b>Proportional Dec Band</b>	2 to 10		6.0	
<b>Proportional ECW Gain</b>	1 to 3		2.0	
<b>Guide Vane Travel Limit</b>	30 to 100	%	50	

<b>HOLIDAY (HOLIDEF) CONFIGURATION SHEET HOLIDEF__S</b>			
<b>DESCRIPTION</b>	<b>RANGE</b>	<b>UNITS</b>	<b>VALUE</b>
<b>Holiday Start Month</b>	1 to 12		
<b>Start Day</b>	1 to 31		
<b>Duration</b>	0 to 99	DAYS	

<b>HOLIDAY (HOLIDEF) CONFIGURATION SHEET HOLIDEF__S</b>			
<b>DESCRIPTION</b>	<b>RANGE</b>	<b>UNITS</b>	<b>VALUE</b>
<b>Holiday Start Month</b>	1 to 12		
<b>Start Day</b>	1 to 31		
<b>Duration</b>	0 to 99	DAYS	

<b>HOLIDAY (HOLIDEF) CONFIGURATION SHEET HOLIDEF__S</b>			
<b>DESCRIPTION</b>	<b>RANGE</b>	<b>UNITS</b>	<b>VALUE</b>
<b>Holiday Start Month</b>	1 to 12		
<b>Start Day</b>	1 to 31		
<b>Duration</b>	0 to 99	DAYS	

NOTE: There are no HOLIDAYS defined on the default menu. HOLIDAY dates must be updated yearly if they are used.

<b>BROADCAST (BRODEFS) CONFIGURATION SHEET</b>				
<b>DESCRIPTION</b>	<b>RANGE</b>	<b>UNITS</b>	<b>DEFAULT</b>	<b>VALUE</b>
<b>Activate</b>	Yes/No		No	
<b>OAT Broadcast</b>				
<b>Controller Name</b>	8 characters	Text		
<b>Bus Number</b>	0 to 239	Bus #s	0	
<b>Element Number</b>	0 to 239	SE #s	0	
<b>OARH Broadcast</b>				
<b>Controller Name</b>	8 characters	Text		
<b>Bus Number</b>	0 to 239	Bus #s	0	
<b>Element Number</b>	0 to 239	SE #s	0	
<b>Daylight Savings Start</b>				
<b>Month</b>	1 to 12		4	
<b>Day</b>	1 to 31		15	
<b>Time</b>	00:00 to 23:59	HH:MM	02:00	
<b>Minutes To Add</b>	1 to 1440	MIN	60	
<b>Daylight Savings Stop</b>				
<b>Month</b>	1 to 12		10	
<b>Day</b>	1 to 31		15	
<b>Time</b>	00:00 to 23:59	HH:MM	02:00	
<b>Minutes To Subtract</b>	1 to 1440	MIN	60	



## Free Manuals Download Website

<http://myh66.com>

<http://usermanuals.us>

<http://www.somanuals.com>

<http://www.4manuals.cc>

<http://www.manual-lib.com>

<http://www.404manual.com>

<http://www.luxmanual.com>

<http://aubethermostatmanual.com>

Golf course search by state

<http://golfingnear.com>

Email search by domain

<http://emailbydomain.com>

Auto manuals search

<http://auto.somanuals.com>

TV manuals search

<http://tv.somanuals.com>