

## Controls Troubleshooting Guide

All Model E Units Have Microprocessor Controls  
and Electronic Expansion Valves

### CONTENTS

	Page
<b>SAFETY CONSIDERATIONS</b> .....	1
<b>FLOTRONIC PLUS CONTROL SYSTEM</b> .....	1-4
<b>General</b> .....	1
<b>Features</b> .....	2
PROCESSOR MODULE .....	2
• LOW-VOLTAGE RELAY MODULE .....	2
EXV (ELECTRONIC EXPANSION VALVE) DRIVER MODULE .....	2
KEYBOARD AND DISPLAY MODULE .....	2
ELECTRONIC EXPANSION VALVE .....	3
• THERMISTORS .....	3
CAPACITY CONTROL .....	3
<b>CONTROL SEQUENCE</b> .....	4,5
Off Cycle .....	4
Start-Up .....	4
Capacity Control .....	4
• SEQUENCE .....	4
Unit Shutdown .....	5
Complete Unit Stoppage .....	5
Single-Circuit Stoppage .....	5
Lag Compressor Stoppage .....	5
Restart Procedure .....	5
• GENERAL POWER FAILURE .....	5
• BLOWN FUSE IN POWER FEED DISCONNECT .....	5
• LOW WATER TEMPERATURE CUTOFF .....	5
• AUXILIARY INTERLOCK .....	5
• OPEN CONTROL CIRCUIT FUSE .....	5
• FREEZE PROTECTION .....	5
• HIGH-PRESSURE SWITCH .....	5
• LOSS OF CHARGE SWITCH .....	5
• COMPRESSOR DISCHARGE TEMPERATURE SWITCH .....	5
• OIL SAFETY SWITCH .....	5
<b>CONTROLS OPERATION</b> .....	5-11
Accessing Functions and Subfunctions .....	5
Display Functions .....	5
• SUMMARY DISPLAY .....	5
• STATUS FUNCTION .....	5
• TEST FUNCTION .....	10
Programming Functions .....	11
• SERVICE FUNCTION .....	11
• SET POINT FUNCTION .....	11
• SCHEDULE FUNCTION .....	11
<b>TROUBLESHOOTING</b> .....	12-26
Checking Display Codes .....	12
• OPERATING MODE CODES .....	12
• ALARM CODES .....	12
Quick Test .....	14
Electronic Expansion Valves .....	19
• CHECKOUT PROCEDURE .....	19
• EXV OPERATION .....	21
Thermistors .....	22
• LOCATION .....	22
• SENSOR REPLACEMENT .....	22
Modules .....	23

### SAFETY CONSIDERATIONS

Installation, start-up and servicing of this equipment can be hazardous due to system pressures, electrical components and equipment location.

Only trained, qualified installers and service mechanics should install, start-up and service this equipment.

When working on the equipment, observe precautions in the literature, tags, stickers and labels attached to the equipment and any other safety precautions that apply.

- Follow all safety codes.
- Wear safety glasses and work gloves.
- Use care in handling, rigging and setting bulky equipment.
- Use care in handling electronic components.

	<p><b>ELECTRIC SHOCK HAZARD.</b> Open all remote disconnects before servicing this equipment.</p>
---	---

<p><b>▲ WARNING</b></p>
<p>This unit uses a microprocessor-based electronic control system. Do not use jumpers or other tools to short out components, bypass or otherwise depart from recommended procedures. Any short-to-ground of the control board or accompanying wiring may destroy the electronic modules or electrical component.</p>

### FLOTRONIC PLUS CONTROL SYSTEM

**General** — The 30HR,HS Flotronic Plus chillers feature microprocessor-based electronic controls and an electronic expansion valve (EXV) in each refrigeration circuit.

The Flotronic Plus control system cycles compressors and compressor unloaders to maintain the selected leaving water temperature set point. It automatically positions the EXV to maintain the specified refrigerant superheat entering the cylinders of the compressor. Safeties are continuously monitored to prevent the unit from operating under unsafe conditions. A scheduling function, programmed by the user, controls the unit occupied/unoccupied schedule. The control also operates a Quick Test program that allows the operator to check input and output signals to the microprocessor.

The control system consists of a processor module (PSIO), low-voltage relay module (DSIO), electronic expansion valve (EXV), EXV driver module (DSIO), keyboard and display module (HSIO) and thermistors to provide analog inputs to the microprocessor. The software resides in the PSIO.

Manufacturer reserves the right to discontinue, or change at any time, specifications or designs without notice and without incurring obligations.

**Features** — The 30HR,HS control panel is shown in Fig. 1.

**PROCESSOR MODULE** This module contains the operating software and controls the operation of the machine. It continuously monitors information received from the various temperature thermistors and communicates with the relay module to increase or decrease the active stages of capacity. The processor module also controls the EXV driver module, commanding it to open or close each electronic expansion valve in order to maintain approximately 20 F of superheat entering the cylinders of each of the lead compressors. Information is transmitted between the processor module and the relay module, EXV driver module and keyboard display module through a 3-wire communications bus.

**EXV (ELECTRONIC EXPANSION VALVE) DRIVER MODULE** -- The EXV driver module operates the electronic expansion valves (based on commands from the processor) and monitors the status of the oil pressure switches and the refrigerant loss of charge switches.

If the loss of charge switch opens due to a low refrigerant charge, the EXV driver module detects a zero voltage condition in the loss of charge switch electrical circuit and communicates this information to the processor module. The processor module immediately shuts down all compressors in the affected refrigeration circuit.

During operation, if the EXV driver module detects zero voltage in the oil pressure switch electrical circuit for 45 consecutive seconds (due to an open oil pressure switch), it communicates this information to the processor module. The processor module immediately shuts down all compressors in the affected refrigeration circuit. At start-up, if the oil pressure switch has not closed by the end of a 60-second time period the EXV driver module senses this and the processor module immediately shuts down all compressors in the affected refrigeration circuit.

If a shutdown occurs due to loss of charge or low oil pressure, the EXV driver module communicates this to the processor module and the processor module locks the compressors off in the affected refrigeration circuit.

The proper fault code(s) will appear on the display whenever a safety switch opens.

**KEYBOARD AND DISPLAY MODULE** (Fig. 2) This device consists of a keyboard with 6 function keys, 5 operative keys, 12 numeric keys (0 to 9, ,, -) and an alphanumeric g-character LCD. Key usage is explained in Table 1.

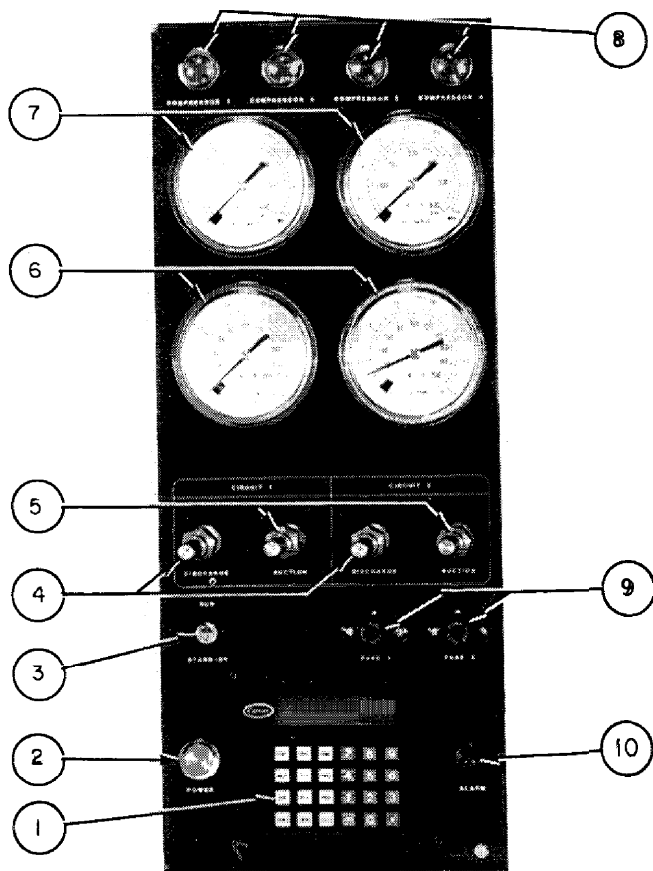

- 1 — Keyboard/Display Module
- 2 — Control Power ON Light
- 3 — RUN/STANDBY Switch
- 4 — Discharge Pressure Gage Valves
- 5 — Suction Pressure Gage Valves
- 6 — Suction Pressure Gages
- 7 — Discharge Pressure Gages
- 8 — Compressor ON Lights
- 9 — Control Circuit Fuses
- 10 — Alarm Light

**Fig. 1 — Control Panel**

**LOW-VOLTAGE RELAY MODULE** -- This module closes contacts to energize compressors, solenoid valves and unloaders. It also senses the condition of the compressor safeties and transmits this information to the processor module.

**Table 1 — Keyboard and Display Module Key Usage**

FUNCTION KEYS	USE
STAT	Status — Displaying diagnostic codes and current operating information about the machine
TEST	Quick Test — Checking inputs and outputs for proper operation
HIST	History — This key appears on the keyboard, but is not used on the 30HR,HS Model E machines
SRVC	Service — Entering specific unit configuration information
SET	Set Point — Entering operating set points and day/time information
SCHD	Schedule — Entering occupied/unoccupied schedules for unit operation
OPERATIVE KEYS	USE
EXPN	Expand Display — Displaying a non-abbreviated expansion of the display
CLR	Clear — Clearing the screen of all displays
↑	Up Arrow — Returning to previous display position
↓	Down Arrow — Advancing to next display position
ENTR	Entering data

Each function has one or more subfunctions as shown in Table 2. These functions are defined in greater detail in the Controls Operation section of this book.

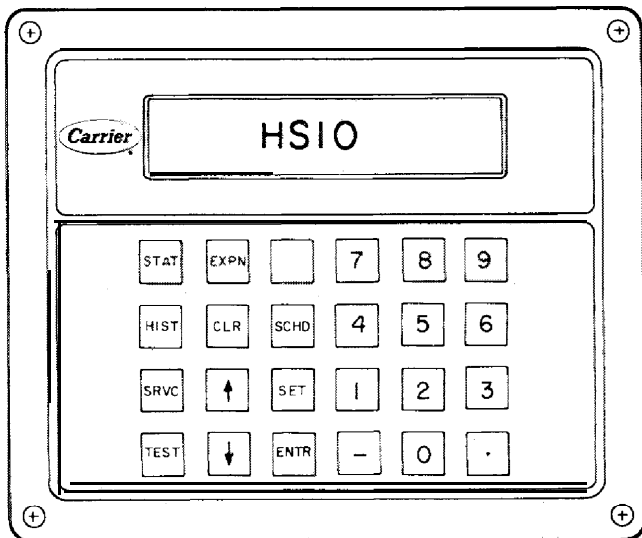

Fig. 2 — Keyboard and Display Module

**ELECTRONIC EXPANSION VALVE** — The microprocessor controls the electronic expansion valve through the EXV driver module. Inside the expansion valve is a linear actuator stepper motor. To control the stepper motor's position, the thermistor in the cooler and the thermistor in the lead compressor in each circuit are used to maintain a 20 F (11 C) difference. Because the compressor sensor is after the compressor motor, which adds approximately 15 F (8.3 C) superheat, the 20 F (11 C) control temperature results in 0° F to 5 F (2.8 C) superheat leaving the cooler. This improves the performance of the cooler.

At initial start-up the valve position is initialized to 0. After that, the microprocessor keeps accurate track of the valve position in order to use this information as input for the other control functions.

The control monitors the superheat and the rate of change of superheat to control the position of the valve. The valve stroke is very large; this results in very accurate control of the superheat.

The electronic expansion valve is also used to limit the maximum saturated suction temperature to 55 F (12.8 C) to keep from overloading the compressor during high cooler water temperatures. This allows the unit to start with very warm water temperatures.

**THERMISTORS** — The electronic control uses 7 thermistors to sense temperatures used to control the operation of the chiller. Sensors are listed in Table 3.

**CAPACITY CONTROL** The control cycles compressors and alternately loads and unloads cylinders to give capacity control steps as shown in Table 4. The unit controls leaving chilled water temperature. Entering water temperature is used by the microprocessor in determining the optimum time to load and unload, but is not a control set point.

The chilled water temperature set point can be automatically reset by the return temperature reset or space and outside air temperature reset features.

Table 2 — Function and Subfunctions

SUBFUNCTION NUMBER	FUNCTIONS				
	Status	Test	Service	Set Point	Schedule
1	Alarm Displays	Quick Test of Inputs	Log On and Log Off	System (Chilled Water)	Occupied Mode Override
2	Operating Mode Displays	Quick Test of Outputs	Software Version	Reset	Schedule Type
3	Capacity Stages	Quick Test of Compressors	Factory Configurations	Demand Limit	Period 1
4	Current Operating Set Points	Terminate Quick Test	Field Configurations	Time	Period 2
5	System Temperatures	—	—	—	Period 3
6	System Pressures	—	—	—	Period 4
7	EXV Position	—	—	—	Period 5
8	—	—	—	—	Period 6
9	—	—	—	—	Period 7
10	—	—	—	—	Period 8

**Table 3 — Thermistors**

**CONTROL SEQUENCE**

SENSOR	TEMPERATURE
T1	Cooler Leaving Water
T2	Cooler Entering Water
T5	Cooler Saturated Suction Temperature — Circuit A
T6	Cooler Saturated Suction Temperature — Circuit B
T7	Compressor Suction Gas Temperature — Circuit A
T8	Compressor Suction Gas Temperature — Circuit B
T10	Reset Temperature Sensor (Accessory)

The control power (115-1-60 for 60-Hz units; 230-1-50 for 50-Hz units) must be supplied directly from a separate source through a code-approved fused disconnect to the L1 and L2 terminals of unit power terminal block.

**NOTE:** There is no switch or circuit breaker; only fuses. If the control power feed is live, so is the circuit.

Crankcase heaters are wired into the control circuit. They are always operative as long as control circuit power is on even though unit may be off because of safety device action. Heaters are wired so they are on only when their respective compressors are cycled off.

**▲ WARNING**

The control circuit power must never be off except when unit is being serviced.

*After a prolonged shutdown, the crankcase heaters should be on for 24 hours before starting the unit.*

When power is supplied to control circuit, unit is ready for operation providing all safety devices are satisfied, interlocks are closed and instructions on warning labels have been followed.

If schedule function is used, refer to page 11 for details on control operation.

**Off Cycle —** During unit off cycle when the RUN; STANDBY switch is in the STANDBY position, the crankcase heaters and the control system are energized. The electronic expansion valves are also energized. (NOTE: The control circuit power must be on at all times even when the main unit power is off.)

**Start-Up —** When the RUN/STANDBY switch is moved from the STANDBY to the RUN position and there is a call for cooling, after 1-1/2 to 3 minutes have passed the first compressor will start unloaded. The first circuit to start may be circuit A or B due to the automatic lead/ lag feature.

**Capacity Control —** (See Table 4.) The rate at which the compressors are turned on will depend on the leaving water temperature difference from the set point, the rate of change of leaving water temperature, the return water temperature and the number of compressor stages on. The control is primarily from leaving water temperature and the other factors are used as compensation.

**SEQUENCE --** On a call for cooling, the control system starts the initial compressor. The control will randomly select either circuit A or B. The liquid line solenoid valve remains closed for 10 seconds after the initial compressor on that refrigeration circuit starts. This permits a pump-out cycle at start-up to minimize refrigerant floodback to the compressor. If the compressor in that refrigeration circuit has run in the 15 minutes before the call for cooling, the pumpout cycle is bypassed.

After pumpout, the liquid line solenoid valve opens and the electronic expansion valve starts to open.

The electronic expansion valve will open gradually to provide a controlled start-up to prevent liquid floodback to the compressor. Also during this period, the oil pressure switch will be bypassed for one minute.

As additional cooling is required, the control system will ramp up through the capacity steps available until the load requirement is satisfied. As capacity steps are added compressors are brought on line, alternating between the lead and lag refrigerant circuits. As explained previously, the speed at which capacity is increased or decreased is controlled by the temperature deviation from the set point and the rate of change in the chilled water temperature.

**Table 4 Capacity Control Steps**

UNIT 30HR 30HS	CONTR STEPS	SEQUENCE A								SEQUENCE B							
		% Cap.	Tot.	Oper Cylinders				% Cap.	Tot.	Oper Cylinders							
				Ckt A		Ckt B				Ckt A		Ckt B					
				A1	A2	B1	B2			A1	A2	B1	B2				
070	1	14.3	2	2	—	—	—	28.6	4	4	—	—	—	—			
	2	42.9	6	2	—	4	—	42.9	6	2	—	4	—				
	3	57.2	8	2	—	6	—	57.2	8	4	—	4	—				
	4	71.2	10	4	—	6	—	71.2	10	4	—	6	—				
	5	85.7	12	2	4	6	—	85.7	12	2	4	6	—				
	6	100.0	14	4	4	6	—	100.0	14	4	4	6	—				
080	1	25.0	4	4	—	—	—	25.0	4	—	—	4	—				
	2	50.0	8	4	—	4	—	50.0	8	4	—	4	—				
	3	62.5	10	4	—	6	—	62.5	10	6	—	4	—				
	4	75.0	12	6	—	6	—	75.0	12	6	—	6	—				
	5	87.5	14	4	4	6	—	87.5	14	4	4	6	—				
	6	100.0	16	6	4	6	—	100.0	16	6	4	6	—				
090	1	22.2	4	4	—	—	—	22.2	4	—	—	4	—				
	2	44.4	8	4	—	4	—	44.4	8	4	—	4	—				
	3	55.5	10	4	—	6	—	55.5	10	6	—	4	—				
	4	66.7	12	6	—	6	—	66.7	12	6	—	6	—				
	5	88.8	16	4	6	6	—	88.8	16	4	6	6	—				
	6	100.0	18	6	6	6	—	100.0	18	6	6	6	—				
100	1	20.0	4	4	—	—	—	20.0	4	—	—	4	—				
	2	40.0	8	4	—	4	—	40.0	8	4	—	4	—				
	3	50.0	10	4	—	6	—	50.0	10	6	—	4	—				
	4	60.0	12	6	—	6	—	60.0	12	6	—	6	—				
	5	70.0	14	4	4	6	—	70.0	14	6	—	4	4				
	6	80.0	16	6	4	6	—	80.0	16	6	—	6	4				
	7	90.0	18	4	4	6	4	90.0	18	6	4	4	4				
	8	100.0	20	6	4	6	4	100.0	20	6	4	6	4				
110	1	18.2	4	4	—	—	—	18.2	4	—	—	4	—				
	2	36.3	8	4	—	4	—	36.3	8	4	—	4	—				
	3	45.4	10	4	—	6	—	45.4	10	6	—	4	—				
	4	54.5	12	6	—	6	—	54.5	12	6	—	6	—				
	5	72.7	16	4	6	6	—	63.6	16	6	—	4	4				
	6	81.8	18	6	6	6	—	72.7	18	6	—	6	4				
	7	90.9	20	4	6	6	4	90.9	20	6	6	4	4				
	8	100.0	22	6	6	6	4	100.0	22	6	6	6	4				
120, 160	1	16.6	4	4	—	—	—	16.6	4	—	—	4	—				
	2	33.3	8	4	—	4	—	33.3	8	4	—	4	—				
	3	41.6	10	4	—	6	—	41.6	10	6	—	4	—				
	4	50.0	12	6	—	6	—	50.0	12	6	—	6	—				
	5	66.7	16	4	6	6	—	66.7	16	6	—	4	6				
	6	75.0	18	6	6	6	—	75.0	18	6	—	6	6				
	7	91.6	22	4	6	6	6	91.6	22	6	6	4	6				
	8	100.0	24	6	6	6	6	100.0	24	6	6	6	6				
140	1	19.0	4	4	—	—	—	19.0	4	—	—	4	—				
	2	38.0	8	4	—	4	—	38.0	8	4	—	4	—				
	3	47.6	10	4	—	6	—	47.6	10	6	—	4	—				
	4	57.0	12	6	—	6	—	57.0	12	6	—	6	—				
	5	69.0	16	4	6	6	—	69.0	16	6	—	4	6				
	6	78.6	18	6	6	6	—	78.6	18	6	—	6	6				
	7	90.4	22	4	6	6	6	90.4	22	6	6	4	6				
	8	100.0	24	6	6	6	6	100.0	24	6	6	6	6				

NOTE: Circuits and compressors designated from left to right when viewed from front of unit.

When the second or lag refrigeration circuit is started, the circuit will go through a 10-second pumpout unless the circuit has been operating in the 15 minutes prior to this start.

Upon load reduction, the control system will unload the unit in the reverse order of loading until the capacity nearly matches the load. Each time the lead compressor is cycled off, the liquid line solenoid valve and electronic expansion valve will be closed for 10 seconds prior to compressor shutdown to clear the cooler of liquid refrigerant.

**Unit Shutdown** To stop unit, move the RUN/STANDBY switch to the STANDBY position. Any refrigeration circuit that is operating at this time will continue for 10 seconds to complete the pumpout cycle. (Lag compressors stop immediately, lead compressors run for 10 seconds.)

**Complete Unit Stoppage** can be caused by any of the following conditions:

- general power failure
- blown fuse in control power feed disconnect
- open control circuit fuse
- RUN/STANDBY switch moved to STANDBY
- freeze protection trip
- low flow protection trip
- open contacts in chilled water flow switch (optional)
- open contacts in any auxiliary interlock. (Terminals TBI-13 and TBJ-14, jumpered from factory, are in series with the control switch. Opening the circuit between these terminals places the unit in STANDBY mode, just as moving the control switch to STANDBY would. Code26 will appear as the operating mode in the status function display. The unit cannot start if these contacts are open, and if they open while unit is running, it will pump down and stop.

**Single Circuit Stoppage** can be caused by the following:

- open contacts in lead compressor discharge gas thermostat
- open contacts in loss of charge switch
- open contacts in oil safety switch
- open contacts in lead compressor high-pressure switch

Stoppage of one circuit by a safety device action does not affect the other circuit. Besides stopping compressor(s), all devices listed will also close liquid line solenoid valve for that circuit.

**Lag Compressor Stoppage** can be caused by the following:

- open contacts in discharge gas thermostat
- open contacts in high-pressure switch

### ▲ CAUTION

If stoppage occurs more than once as a result of any of the above safety devices, determine and correct the cause before attempting another restart.

**Restart Procedure**, after cause for stoppage is corrected.

**GENERAL POWER FAILURE** Unit will restart automatically when power is restored.

**BLOWN FUSE IN POWER FEED DISCONNECT** - Replace fuse. Restart is automatic.

**LOW WATER TEMPERATURE CUTOUT** Move RUN/STANDBY switch to STANDBY, then back to RUN. Restart is automatic.

**AUXILIARY INTERLOCK** Automatic restart after condition is corrected.

**OPEN CONTROL CIRCUIT FUSE** - Replace fuse. Unit will restart automatically.

**FREEZE PROTECTION** - Unit will automatically restart when leaving water temperature is 6 degrees F above the leaving water set point.

**HIGH-PRESSURE SWITCH, LOSS OF CHARGE SWITCH, COMPRESSOR DISCHARGE TEMPERATURE SWITCH AND OIL SAFETY SWITCH** -- Move the RUN/STANDBY switch to STANDBY, then back to RUN. Unit will restart automatically.

## CONTROLS OPERATION

### Accessing Functions and Subfunctions

Table 5. Refer also to Table 2, which shows the 5 functions (identified by name) and the subfunctions (identified by number). Table 6 shows the sequence of all the elements in a subfunction.

### Display Functions

**SUMMARY DISPLAY** Whenever the keyboard has not been used for 10 minutes, the display will automatically switch to an alternating summary display. This display has 4 parts, shown below, which alternate in continuous rotating sequence.

Display	Expansion
TUE 12:45	TODAY IS TUE, TIME IS 12:45
MODE 26	UNIT STANDBY
1 STAGES	NUMBER OF STAGES IS 1
2 ALARMS	2 ALARMS DETECTED

**STATUS FUNCTION** - The status function shows the current status of alarm (diagnostic) codes, capacity stages, operating modes, chilled water set point, all measured system temperatures, superheat values, pressure switch positions and expansion valve positions. These subfunctions are defined below. Refer to Table 6 for additional information.

**STAT** (Alarms) Alarms are messages that one or more faults have been detected. Each fault is assigned a code number which is reported with the alarm. (See Table 7 for code definitions.) The codes indicate failures that cause the unit to shut down, terminate an option (such as reset) or result in the use of a default value as set point.

Up to 3 alarm codes can be stored at once. To view them in sequence, press **|** **STAT** to enter the alarm displays and then press **↓** key to move to the individual alarm displays. Press **EXPN** after a code has been displayed and the meaning of code will scroll across the screen.

When a diagnostic (alarm) code is stored in the display and the machine automatically resets, the code will be deleted. Codes for safeties which do not automatically reset will not be deleted until the problem is corrected and the machine is switched to STANDBY, then back to RUN.

*continued on page 10*

**Table 5 — Accessing Functions and Subfunctions**













OPERATION	KEYBOARD ENTRY	DISPLAY	DESCRIPTION
<p>To access a function, press the subfunction number and the function name key. The display will show the subfunction group</p> <p>To move to the other elements, scroll up or down using the arrow keys</p>	<p> </p> <p></p> <p></p> <p></p>	<p>RESET</p> <p>RSP</p> <p>RSTL</p> <p>RSTR</p>	<p>Reset Set Points</p> <p>Reset Set Point</p> <p>Reset Limit</p> <p>Reset Ratio</p>
<p>When the last element in a subfunction has been displayed, the first element will be repeated</p>	<p></p>	<p>RSP</p>	<p>Reset Set Point</p>
<p>To move to the next subfunction, it is not necessary to use the subfunction number; pressing the function name key will advance the display through all subfunctions within a function and then back to the first</p>	<p></p> <p></p> <p></p>	<p>DEMAND</p> <p>TIME</p> <p>SET POINT</p>	<p>Demand Limit Set Points</p> <p>Time of Day and Day of Week Display</p> <p>System Set Points</p>
<p>To move to another function, either depress the function name key for the desired function (display will show the first subfunction)</p> <p>or</p> <p>Access a particular subfunction by using the subfunction number and the function name key</p>	<p></p> <p>or</p> <p> </p>	<p>X ALARMS</p> <p>STAGES</p>	<p>X Alarms Detected</p> <p>Capacity Stages</p>

Table 6 — Keyboard Directory

STATUS		
KEYBOARD ENTRY	DISPLAY	COMMENT
1 <input type="button" value="STAT"/>	X ALARMS	Current alarm displays
	ALARM X	Alarm 1
	ALARM X	Alarm 2
	ALARM X	Alarm 3
2 <input type="button" value="STAT"/>	MODE	Current operating mode displays
	MODE X	Mode 1
3 <input type="button" value="STAT"/>	STAG ES	Capacity stages
	X STAGE	Stage number
4 <input type="button" value="STAT"/>	SET POINT	Current operating set point
	CWS X	Leaving chilled water set point
If unit is in dual set point mode the set point currently in effect is displayed.		
	LWT X	Leaving water temperature
5 <input type="button" value="STAT"/>	TEMPS	System temperatures
	LWT X	Cooler leaving water temp
	EWT X	Cooler entering water temp
	SSTA X	Saturated suction temp circuit A
	CGTA X	Compressor suction gas temperature circuit A
	SHA X	Superheat temp circuit A
	SSTB X	Saturated suction temp circuit B
	CGTB X	Compressor suction gas temperature circuit B
	SHB X	Superheat temp circuit B
	RST X	Reset temperature
6 <input type="button" value="STAT"/>	PRESS	Systems pressures
	LCSA X	Circuit A loss of charge switch
	OILA X	Circuit A oil pressure switch
	LCSB X	Circuit B loss of charge switch
	OILB X	Circuit B oil pressure switch
7 <input type="button" value="STAT"/>	ANALOG	System analog values
	EXVA X	Circuit A EXV valve position
	EXVB X	Circuit B EXV valve position

QUICK TEST		
KEYBOARD ENTRY	DISPLAY	COMMENT
1 <input type="button" value="TEST"/>	INPUTS	Factory/field test of inputs
	LWT X	Leaving water temperature
	EWT X	Entering water temperature
	SSTA X	Saturated suction temp circuit A
	CGTA X	Compressor suction gas temp circuit A
	SSTB X	Saturated suction temp circuit B
	CGTB X	Compressor suction gas temp circuit B
	RST X	Reset temperature
	LCSA X	Loss of charge switch circuit A
	ILCSB X	Loss of charge switch circuit B
	OILA X	Oil pressure switch circuit A
	OILB X	Oil pressure switch Circuit B
2 <input type="button" value="TEST"/>	OUTPUTS	Factory/field test of outputs
	SLDA X	Circuit A liquid line solenoid test
	SLDB X	Circuit B liquid line solenoid test
	UNLA X	Unloader A test
	UNLB X	Unloader B test
	EXVAO X	Circuit A EXV open test
	EXVAC X	Circuit A EXV close test
3 <input type="button" value="TEST"/>	COMP	Factory/field test of compressors
	CA1 X	Circuit A compressor 1 test
	CA2 X	Circuit A compressor 2 test
	CB1 X	Circuit B compressor 1 test
CB2 X	Circuit B compressor 2 test	
4 <input type="button" value="TEST"/>	END TEST	Leave quick test

**⚠ WARNING**

During test of compressors, each compressor will start and run for 10 seconds. Compressor servicevalves and the liquid line valve must be open. Energize compressor crankcase heaters for 24 hours prior to performing compressor tests.

Table 6 — Keyboard Directory (cont)

SERVICE CONFIGURATIONS		
KEYBOARD ENTRY	DISPLAY	COMMENT
[1] [SRVC]	LOGON	Now enter password
[1] [1] [1] [1] [ENTR]	LOGGED ON	
When finished with configurations, log out as follows:		
[1] [SRVC]	LOGGED ON	Shows that configurations available
[↓]	LOG OFF	
[ENTR]	EXIT LOG	Configurations now again password protected
[2] [SRVC]	VERSION	Software version number
[↓]	xxx	Software version
[↓]	xxx	Language option
[3] [SRVC]	FACT CFG	Factory configuration
[↓]	COMP X	Number of unloaders (enter number, or. for zero)
[4] [SRVC]	FFD CFG	Field configuration ( ) = entry codes
[↓]	UNLS X	Number of unloaders (enter number)
[↓]	RSTP X	Reset type (, = none 1 = return water, 2 = space or outside air)
[↓]	LDSH X	Load shed enable (, = disable, 1 = enable)
[↓]	FLD X	Ftuid type (, = water, 1 = brine)
[↓]	PLDN X	Pulldown enable (, = disable, 1 = enable)

SET POINT		
KEYBOARD ENTRY	DISPLAY	COMMENT
[1] [SET]	SET POINT	System set points
[↓]	icwso x	Occupied chilled water set point
[↓]	icwsu x	Unoccupied chilled water set point appears only when unit is in dual set point mode
[↓]	MSP X	Modified chilled water set point (read only). Set point determined by reset function
[2] [SET]	RESET	Reset set points
[↓]	RSP X	Reset set point
[↓]	RSTL X	Reset limit
[↓]	RSTR X	Reset ratio
[3] [SET]	DEMAND	Demand limit set points
[↓]	DL1 X	Demand limit set point
[↓]	DL2 X	Demand limit set point 2
[4] [SET]	TIME	
[↓]	DAY 00.00	Current setting

SCHEDULE		
KEYBOARD ENTRY	DISPLAY'	'COMMENT'
[1] [SCHD]	OVRD X	Entering number of hours to extend
[2] [SCHD]	SCHTYP X	Schedule Type ( ) = entry codes (, = inactive, 1 = single set point, 2 = dual set point)
[3] [SCHD]	PERIOD 1	Define time schedule period 1
[↓]	OCC XX,XX	Start of occupied time
[↓]	UNO XX,XX	Return to unoccupied time
[↓]	MON X	Monday flag ( ) = entry codes (1 = yes, . = no)
[↓]	TUE X	
[↓]	WED X	
[↓]	THU X	
[↓]	FRI X	
[↓]	SAT x	
[↓]	SUN X	Sunday flag
[4] [SCHD]		Time periods 2-8 (same elements as period 1)
[↓]		
[↓]		
[↓]		
[1] [0] [SCHD]		



**Table 7 Display Codes**

OPERATING MODES	
Display	Description
21	Temperature reset in effect
22	Demand limit in effect
24	Pulldown control in effect
26	Unit standby
27	Unoccupied mode
28	Run mode

ALARMS				
Display	Description	Action Taken By Control	Reset Method	Probable Cause
	<i>Unit Size 070-090 100-160</i>			
51	Comp A1 A1 Failure	Circuit A shut off	Manual	High pressure switch trip or high discharge gas temp switch trip, on when it is not supposed to be on. Wiring error between electronic control and compressor relay.
52	Comp A2 A2 Failure	Comp shut off	Manual	
53	Comp B1 B1 Failure	Circuit B shut off	Manual	
54	Comp B2 B2 Failure	Comp shut off	Manual	
59	Loss of charge circuit A	Circuit A shut off	Manual	Low refrigerant charge, or loss of charge pressure switch failure.
60	Loss of charge circuit B	Circuit B shut off	Manual	
61	Low cooler flow	Unit shut off	Manual	No cooler flow or reverse cooler flow
63	Low oil pressure circuit A	Circuit A shut off	Manual	Oil pump failure or low oil level, or switch failure.
64	low oil pressure circuit B	Circuit B shut off	manual	
65	Freeze protection	Unit shut off	Auto.	Low cooler flow
66	High suction superheat circuit A	Circuit A shut off	Manual	Low charge or EXV failure, or plugged filter drier.
67	High suction superheat circuit B	Circuit B shut off	Manual	
68	Low suction suerheat circuit A	Circuit A shut off	Manual	EXV failure Or cooler thermistor error.
69	Low suction superheat circuit B	Circuit B shut off	Manual	
71	Leaving water thermistor failure	Unit shut off	Auto.	Thermistor failure, or wiring error, or thermistor not connected to input terminals.
72	Entering water thermistor failure	Use default value	Auto.	
75	Cooler thermistor failure circuit A	Circuit A shut off	Auto.	
76	Cooler thermistor failure circuit B	Circuit B shut off	Auto.	
77	Comp thermistor failure circuit A	Circuit A shut off	Auto.	
78	Comp thermistor failure circuit B	Circuit B shut off	Auto.	
79	Reset thermistor failure	Stop reset	Auto.	

**NOTES:**

- Freeze protection trips at 35 F (1.7 C) for water and 6 degrees F (3.3 degrees C) below set point for brine units. Resets at 6 degrees above set point.
- All auto. reset failures that cause the unit to stop will restart the unit when the error has been corrected.
- All manual reset errors must be reset by moving the control switch to STANDBY then to RUN.
- Valid resistance range for thermistors is 363,000 ohms to 216 ohms.

**2** **STAT** (Modes) The operating mode codes are displayed to indicate the operating status of the unit at a given time. (See Table 7).

The modes are explained in the Troubleshooting section on page 12.

---

**3** **STAT** (Stages) This subfunction displays the capacity stage number, from 1 to 8. See Table 4 for compressor loading sequence to enter the STAGES subfunction, depress **3** **STAT** and use the **↓** key to display the stage number.

---

**4** **STAT** (Set Point) This subfunction displays the leaving water temperature and the Leaving chilled water set point. If the unit is programmed for dual set point, the chilled water set point currently in effect (either occupied or unoccupied) will be displayed. If reset is in effect, the unit will be operating to the modified chilled water set point. This means that the leaving water temperature may not equal the chilled water set point. The modified chilled water set point will not be displayed in the status function. To read the modified chilled water set point, refer to the Set Point Function section, page 11.

To enter the set point subfunction, depress **4** **STAT**, then use the **↓** key to display the leaving chilled water set point followed by the leaving water temperature.

---

**5** **STAT** (Temperature) The temperature subfunction displays the readings at temperature sensing thermistors. To read a temperature, enter **5** **STAT**, then scroll to the desired temperature using **c ↓ 1** key. Table 6 shows the order of the readouts.

---

**STAT** (Pressure) This subfunction displays the status of the oil pressure and loss of charge switches. The display will show LOW or NRM for the oil pressure switch and LOW or SAFE for loss of charge switch.

---

**7** **STAT** (Position) The position subfunction displays the current position of the electronic expansion valves in steps:

Fully Open (760)  
Operating Position ( 160 Minimum)  
Fully Closed, Circuit Shut Down (0)

---

**TEST FUNCTION** — The test operates the Quick Test diagnostic program. When the unit is in STANDBY mode, the test subfunctions will energize the solenoid valves, unloaders, electronic expansion valves and compressors. The solenoids and unloaders will energize for 3 minutes. The expansion valve will travel to fully open in one test and to fully closed in the next. The compressors will energize for 10 seconds. The subfunctions are explained below. Refer to Table 6 for all the elements in the subfunctions.

**1** **TEST** Displays the status of all inputs.

**2** **TEST** — Tests the outputs from the processor, except for compressors.

**TEST** — Tests the compressors.

**4** **TEST** Takes the unit out of Quick Test.

**NOTE:** The Quick Test energizes the alarm light and alarm relay. They will remain energized as long as the unit is in Quick Test.

To reach a particular test, enter its subfunction number and then scroll to the desired test with the **↓** key. A test can be terminated by pressing **c ↓ 1**. Pressing **↓** after a test has started will advance the system to the next test, whether the current one is operating or has timed out. Once in the next step, you may start the test by pressing **ENTR** or advance past it by pressing **c ↓**.

While the unit is in Quick Test, you may access another display or function by depressing the appropriate keys; however, the unit will remain in the Quick Test function until **TEST** is entered, or, if the keyboard is not used for 10 minutes, the unit will automatically leave the Quick Test function.

---

## Programming Functions

**SERVICE FUNCTION** — The service function allows the operator to verify factory configurations and read or change field configurations. The service subfunctions are listed below. (See Table 6 for details.)

**1** **SRVC** — The operator must use this subfunction to log on before performing any other subfunction, and to log off after completing service subfunctions.

**2** **SRVC** — Used to verify software version and language option.

**3** **SRVC** — Used to verify factory configurations (number of compressors).

**4** **SRVC** — Used to read or change field configuration for number of unloaders and reset type and to enable the machine for load shed, pulldown, or brine operation.

NOTE: The **1** key is used to enable or turn on certain functions; the **.** key is used to disable these functions.

When the **.** key is pressed the display will show 00.00.

**SET POINT FUNCTION** -- Set points are entered through the keyboard. Set points can be changed within the upper and lower limits, which are fixed. The ranges are listed below.

### Chilled Water Set Point

Water:

40 to 70 F (4.4 to 21 C)

Brine (Special Order Units):

15 to 70 F (-9.4 to 21 C)

### Reset Set Point

0 to 95 F (-17.8 to 35 C)

### Reset Limit

0 to 80 F (-17.8 to 26.7 C)

### Reset Ratio

0 to 100%

### Demand Limit Set Points

Step 1 Capacity Reduction:

0% to 100%

Step 2 Capacity Reduction:

0% to 100%

Set points are grouped in subfunctions as follows:

**1** **SET** — Displays chilled water set points.

a. The first value shown is the occupied chilled water set point.

b. The next value to be displayed depends on how the schedule function has been programmed. (See below.)

If dual set point has been selected, the next set point after **L - J** has been pressed will be the unoccupied chilled water set point; this will be followed by the modified chilled water set point.

If single set point or inactive schedule has been selected in the schedule function, then when **↓** depressed the display will show the modified chilled water set point.

c. The modified chilled water set point is determined by the microprocessor as a result of the reset function, and is displayed for reference only; it cannot be set or changed by the operator. If reset is not in effect, the modified set point will be the same as either the occupied or unoccupied chilled water set point, according to how the schedule function has been programmed.

**2** **SET** — Displays the reset, reset Limits, and reset ratio set points. These set points are not accessible when reset type has been configured for NONE in the service function.

**3** **SET** — Displays the demand limit set points.

**4** **SET** — Displays time of day and day of week.

**SCHEDULE FUNCTION** This function provides a means to automatically switch the chiller from an occupied mode to an unoccupied mode. When using the schedule function, the chilled water pump relay, located in the unit control box, must be used to switch the chilled water pump on and off. The chilled water pump relay will start the chilled water pump but the compressors will not run until the remote chilled water pump interlock contacts are closed and the leaving chilled water temperature is above set point. If a remote chilled water pump interlock is not used, the first compressor will start (upon a call for cooling) approximately one minute after the chilled water pump is turned on.

The schedule function can be programmed for inactive, single set point, or dual set point operation.

When the schedule is configured for inactive, the chilled water pump relay remains energized continuously but is not used since the chiller is usually controlled by remote chilled water pump interlock contacts.

When the schedule is set for single set point operation, the chilled water pump relay will be energized whenever the chiller is in the occupied mode regardless of whether the chiller is running. When the chiller is in unoccupied mode, the chilled water pump relay will not be energized.

When the schedule is set for dual set point, the chilled water pump relay will be energized continuously, in both occupied and unoccupied modes. The occupied mode places the occupied chilled water set point into effect; the unoccupied mode places the unoccupied chiller water set point into effect.

The schedule consists of from one to 8 *occupied* time periods, set by the operator. These time periods can be flagged to be in effect or not in effect on each day of the week. The day begins at 00.00 and ends at 24.00. The machine will be in unoccupied mode unless a scheduled time period is in effect. If an occupied period is to extend past midnight, it must be programmed in the following manner: Occupied period must end at 24:00 hours (midnight); a new occupied period must be programmed to begin at 00:00 hours.

The time schedule can be overridden to keep the unit in the occupied mode for one, 2, 3 or 4 hours on a one-time basis.

## TROUBLESHOOTING

If necessary, review the Flotronic Plus Control System, Control Sequence, and Controls Operation sections found in this book. Tables 5 and 6 show how to use the keyboard/display module to access functions and sub-functions. (These procedures are also explained in the 30HR,HS Installation, Start-Up and Service Instructions along with examples and details on using the control features. A copy of the installation instructions should be kept handy while troubleshooting.)

**Checking Display Codes** To determine how the machine has been programmed to operate, check the diagnostic information (   ) and operating mode displays (   ). If no display appears, follow the procedures in Troubleshooting, Modules, page 23. If the display is working, continue as follows:

1. Note all the alarm codes displayed (   ).
2. Note all the operating mode codes displayed (   ).
3. Note the leaving chilled water temperature set point in effect and the current leaving water temperature (   ).

If the machine is running, compare the "in effect" leaving water temperature set point with the current water temperature. Remember that if reset is in effect, they may be different because the machine is operating to the modified chilled water set point. If the current temperature is equal to the set point but the set point is not the one desired, recall that if dual set point has been selected in the schedule function, there are 2 set points to which the machine can be operating. Check the programming of the schedule function to see if the occupied or unoccupied set point should be in effect.

**OPERATING MODE CODES** Following is an explanation of the operating mode codes:

**Temperature Reset (21)** In this mode, the unit is using temperature reset to adjust the set point, and the unit is controlling to the modified set point. This means that the leaving water temperature may not equal the chilled water set point. The set point can be modified based on return water, outside air temperature or space temperature.

**Demand Limit (22)** This indicates that the capacity of the unit is being limited by the demand limit control option. The unit may not be able to produce the desired leaving water temperature because the unit may not load to full capacity.

**Pulldown Control (24)** -- If this option is in effect and the cooler water temperature is warm, extra stages will not be added if the water temperature leaving the cooler is decreasing faster than 1° F (0.6 C) per minute.

**Standby (26)** The unit is being held in the standby mode either because the RUN /STANDBY switch is open or a set of relay contacts in series with the RUN/STANDBY switch is open (contacts wired between terminals TB1-13 and TB1-14).

**Unoccupied Mode (27)** -- In dual set point schedule, this mode means the machine is operating to the unoccupied set point. In single set point schedule, this mode shuts down the unit in the same manner as "Unit Standby."

If the schedule is holding the machine off when it is needed, set the schedule for inactive mode until the schedule can be properly reprogrammed. (See the Schedule Function section of the Installation, Start-Up and Service Instructions.) The override feature can also be used to temporarily place the unit in occupied mode.

Enter    , then the number of hours to override (1 to 4), then press  . If the unit is in override and you wish to cancel it, enter zero hours in the same manner.  
Run Mode (28)

To enter the MODES subfunction, depress   and use the  key to determine if more than one mode applies.

### ⚠ WARNING

Do not attempt to bypass, short or modify the control circuit or electronic boards in any way to correct a problem. This could result in component failures or a hazardous operating condition.

**ALARM CODES** The following is a detailed description of each alarm code error and the possible cause. Manual reset of an alarm is accomplished by moving the RUN/STANDBY switch to STANDBY, then back to RUN.

**Codes 5 1-54, Compressor Failure** — If the DSIO relay module relay or control relay feedback switch opens during operation of a compressor, the microprocessor will detect this and will stop the compressor, energize the alarm light, and display a code of 5 1 to 54, depending on the compressor. The compressor will be locked off; to reset, use the manual reset method.

If the lead compressor in a circuit is shut down, all the other compressors in the circuit will be stopped and locked off. Only the alarm code for the lead compressor will be displayed.

The microprocessor has also been programmed to indicate a compressor failure if the feedback terminal on the 2J3 terminal strip receives voltage when the compressor is not supposed to be on.

Following are possible causes for this failure:

**High-Pressure Switch Open** — The high-pressure switch for each compressor is wired in series with the 24-volt power that energizes the compressor control relay. If the high-pressure switch opens during operation the compressor will stop and this will be detected by the microprocessor through the feedback terminals.

**Discharge Gas Thermostat** — The discharge gas thermostat switch in each compressor is also wired in series with the 24-volt power that energizes the control relay (CR). If the switch opens during operation of the compressor, the compressor will be stopped and the failure will be detected through the feedback terminals.

**DSIO Module Failure** If a DSIO relay module relay fails open or closed, the microprocessor will detect this and lock the compressor off and indicate an error.

**Wiring Errors** If a wiring error exists causing the CR or feedback switch not to function properly, the microprocessor will indicate an error.

**Processor (PSIO) Failure** — If the hardware that monitors the feedback switch fails or the processor fails to energize the relay module relay to ON, an error may be indicated.

NOTE: The control does not detect circuit breaker failures. If a circuit breaker trips on the lead compressor in a circuit, a low oil pressure failure will be indicated; on the other compressors, no failure will be indicated.

**Checkout Procedure (Codes 51-54)** → Shut off the main power to the unit. Turn on control power, then step through the Quick Test to the proper compressor number (i.e., failure code 53 is step CBI). Next, energize the step. If the step works correctly, then the failure code is due to:

- HPS open
- DGT open
- Misplaced feedback wire from 2H5 strip to 2J3 strip
- Ground wire and 24-volt feeds reversed on one or more points on 2J3. The 24-volt ground wire (brown) jumps terminals 2, 4, 6 and 8. Feeds from compressors A1, A2, B1 and B2 connect to pins I, 3, 5 and 7.

The processor closes the contacts between 255 terminals 12 and 11 to start the compressor. (See Fig. 3.) The safeties shown to the right of 2.15 must be closed for power to reach the compressor control relay (CR 1) and the feedback input (terminal 1 on 2J3).

Failure of power to terminal 1 on 2J3 when contacts 2J5 11 and 12 should be closed will cause a code 51 alarm.

Terminal 2 on 293 is the other leg of the compressor A1 feedback channel. It is connected to the 24-volt ground.

**Code 59 and 60, Loss of Refrigerant Charge** A loss-of-charge switch is connected to the high-pressure side of the refrigerant system. The microprocessor monitors this switch directly; if it opens, all the compressors in the circuit will be locked off, the alarm will be energized and the display code will appear when the alarm display is accessed. To reset, use the manual reset method (move the RUN/STANDBY switch to STANDBY, then back to RUN).

Following are some possible causes for this alarm:

**Low Refrigerant Charge** If the system refrigerant charge is very low, the microprocessor will detect this through the switch and indicate the error.

**Switch Failure** — If the switch fails open, the microprocessor will detect this and indicate an error.

**Wiring Error** — If there is a wiring error that causes an open circuit, the microprocessor will treat this as an open switch and indicate an error.

**Processor Board Failure** If the hardware in the processor module fails in a manner that the switch cannot be read properly, an error may be indicated.

**Code 61, No Cooler Flow** — The microprocessor contains logic that protects the cooler against loss of cooler flow. The cooler entering and leaving water temperature sensors are used for this purpose. The leaving thermistor is located in the leaving water nozzle and the entering sensor is located in the first cooler baffle space in close proximity to the cooler tubes as shown in Fig. 4. When there is no cooler water flow and the compressors are operating, the leaving water temperature thermistor will indicate no temperature change. But the temperature of the entering water will drop rapidly and the entering water thermistor will detect this. When the entering water temperature drops to 5 F (2.8 C) below the leaving water temperature, all the compressors will stop and code no. 61 will be displayed. To correct, use manual reset method (after cooler water flow is resumed).

The error will be caused either by no cooler flow or if the water is flowing in the wrong direction through the cooler or if the thermistors have been interchanged.

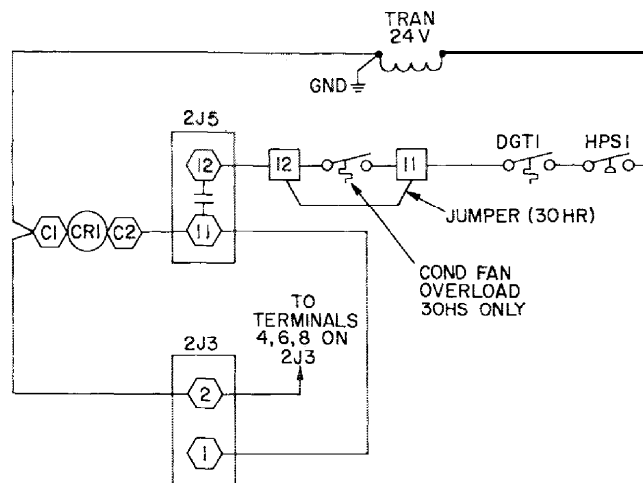

Fig. 3 — Compressor A1 Control Wiring (Typical)

**Code 63 and 64, Low Oil Pressure** A low oil pressure switch is installed on the lead compressor in each circuit. If the switch opens during operation of the compressor, all the compressors in the circuit will be shut off, the alarm light will be energized and the appropriate display code shown. The switch will be bypassed for one minute during start-up and for 45 seconds during normal operation. The manual reset method must be used to reset this safety.

Possible causes for failure are:

**Loss of Oil Pressure** If the oil pressure is below  $5 \pm 1$  psig ( $34.5 \pm 6.9$  kpa), the switch will open.

**Switch Failure** — If the switch fails open, a failure will be indicated.

**Compressor is not running.**

**wiring Error** — If a wiring error exists that causes an open circuit, an error will occur.

**Processor Module Failure** — If the hardware on the processor module fails in a manner that the switch cannot be read properly, an error may be indicated.

**Code 65, Cooler Freeze Protection** — If the leaving water temperature is below 35 F (1.7 C) for a water chiller or is 6 F (3.3 C) below the set point for brine applications, all compressors will be stopped. This safety will automatically reset when the water temperature is 6 F (3.3 C) above the set point.

The causes for this failure are usually due to low cooler flow, or extremely rapid load changes.

**Code 66 and 67, High Suction Superheat** — The microprocessor contains the following logic and if it is satisfied, all the compressors in the circuit will be stopped:

Suction superheat is greater than 75 F (4f.7 C), and saturated cooler suction is less than 55 F (12.8 C) and these 2 conditions have been true for more than 5 minutes.

To reset this, use the manual reset method.

Causes for this failure are:

**Low Refrigerant Charge** — A low refrigerant charge will not allow the correct amount of refrigerant to be fed to the evaporator, which will result in a high superheat.

**Plugged Filter Drier** — If the liquid line filter drier becomes plugged, it can result in not enough refrigerant being fed to the evaporator, which results in a high superheat failure.

**EXV Failure** If the EXV fails to open enough to feed the proper amount of refrigerant, the error will occur.

**EXV Driver Module Failure** — If the DSIO module hardware that controls the EXVs fails, the valve will not move.

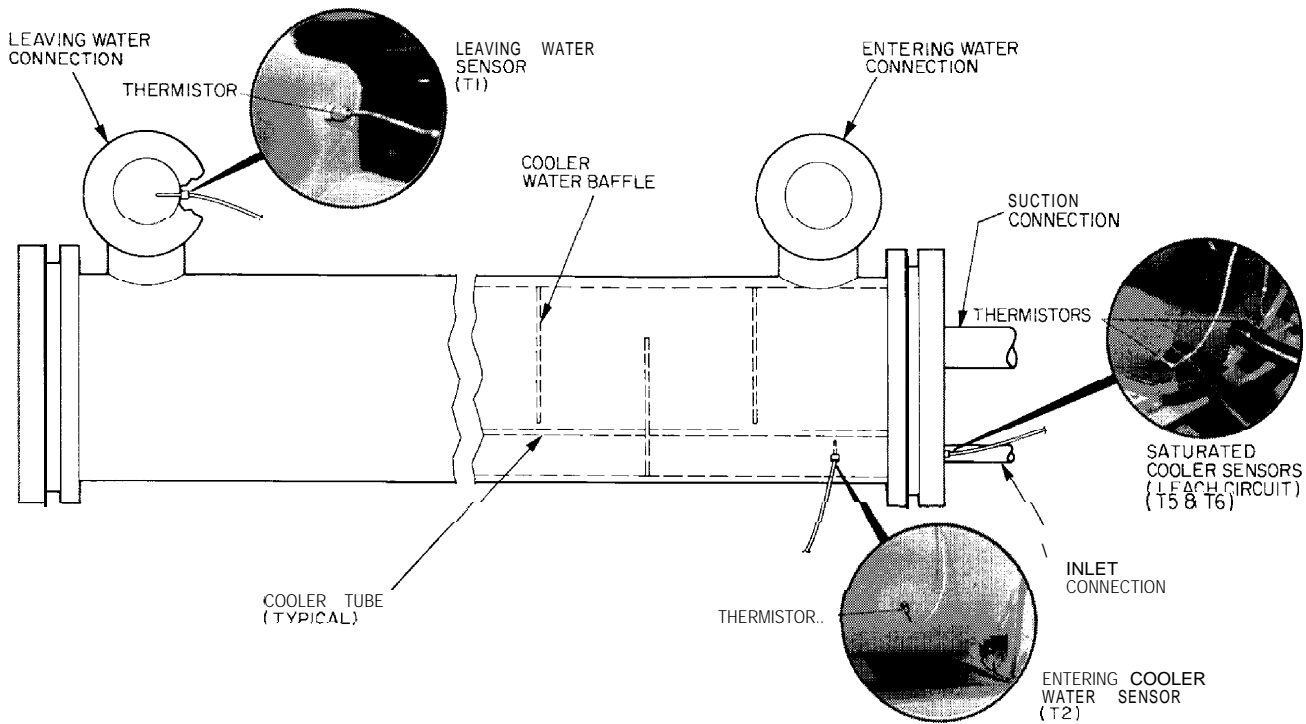

Fig. 4 Cooler Sensor Locations

**Bad Thermistor** Thermistors mis-located or out of calibration.

**Code 68 and 69, Low Suction Superheat** -- if the following logic is satisfied, then all the compressors on the circuit will be stopped.

Suction superheat is equal to 0°F (0°C) or the saturated suction is greater than 58 F (14.4 C) and either condition has been true for more than 5 minutes.

Possible causes for this failure are a stuck electronic expansion valve or thermistors mis-located or out of calibration.

To reset, use the manual reset method.

**Code 71 to 81, Thermistor Failure** If the measured temperature of a thermistor is less than -60 F (-51 C) (363,000 ohms) or greater than 240 F (116 C) (2 16 ohms), the appropriate sensor error code will be displayed and the unit will be stopped. The thermistor failures will automatically reset. The following is a summary of possible causes.

**Thermistor Failure** -- A shorted or open circuit thermistor will cause the failure.

**Wiring Failure** A shorted or open circuit will cause the failure.

**Processor Module Failure** If the circuitry in the processor module fails, the error could occur.



NOTE: The reset thermistor is an optional thermistor and is only used with outside or space temperature reset. It will only be read by the processor if the unit is configured for outside or space temperature reset.

The absence of a thermistor failure does not necessarily mean that a thermistor is accurate. To determine accuracy, the reading must be compared with a measurement of the actual temperature to which the thermistor probe is exposed.

**Quick Test** -- The Quick Test feature allows the service technician to individually test all the inputs and outputs of the control system.

The test function operates the Quick Test diagnostic program. When the unit is in STANDBY mode, the test subfunctions will energize the solenoid valves, unloaders, electronic expansion valves and compressors. The solenoids and unloaders will energize for 3 minutes. The electronic expansion valve will travel to fully open in one test and to fully closed in the next. The compressors will energize for 10 seconds. The subfunctions are explained below. Refer to Table 6 for all the elements in the subfunctions.

NOTE: The Quick Test energizes the alarm light and alarm relay. They will remain energized as long as the unit is in Quick Test.

To reach a particular test, enter its subfunction number and then scroll to the desired test with the  key. A test can be terminated by pressing  $c \downarrow 1$ . Pressing 

after a test has started will advance the system to the next test, whether the current one is operating or has timed out. Once in the next step, you may start the test

by pressing  $c^{ENTR} \downarrow 1$  or advance past it by pressing  $c \downarrow 1$ .

While the unit is in Quick Test, you may access another display or function by depressing the appropriate keys; however, the unit will remain in the Quick Test function until

 is entered, or, if the keyboard is

not used for 10 minutes, the unit will automatically leave the Quick Test function. See the following example:

KEYBOARD ENTRY	DISPLAY RESPONSE	COMMENTS
3 TEST	COMP	Factory field test of compressors subfunction of test function
↓	CA1 OFF	Circuit A, compressor 1 test
ENTR	CA1 ON	Pressing ENTR starts the test; when the compressor should be running the display shows CA1 on
↓	CA1 OFF	If the test is allowed to time out, the display will show CA1 off
↓	CA2 OFF	Pressing the down arrow key advances the system to circuit A, compressor 2 test
4 TEST	END TEST	If no other test is desired, exit quick test

Refer to Fig. 5, 6 and 7 for specific control wiring. Each module in a panel is numbered (1, 2, 3, 4...). Each terminal strip is labeled (J2, J3, J4...). The terminal strip on the machine schematic combines the module and strip numbers. For example, 2J3 is terminal strip J3 on module 2. The module numbers can be found on the component arrangement label.

The **1 TEST** subfunction checks the thermistor and switch inputs. The thermistor tests display the temperature that the thermistor is reading. If the display and the actual temperature do not match, the thermistor and the input channel can each be checked.

To check the thermistor, disconnect its leads from the PSIO terminal (the entire connector can be pulled from the PSIO by pulling the connector to the left). Read the resistance of the thermistor, then find the corresponding temperature in Table 8.

This temperature should match the actual temperature to which the thermistor is exposed.

The thermistor can be checked while connected to the processor by measuring the voltage across its terminals and finding the corresponding temperature in Table 8. This method can only be used if it is certain that the processor circuits are putting out the correct voltage. If there is any doubt, the thermistor should be checked by the resistance method.

The input channel can be tested by removing the thermistor from the terminals and attaching a fixed resistor with a value between 40,000 ohms and 400 ohms. Refer to Table 8 and find the temperature that corresponds to that resistance; this temperature should appear in the Quick Test display.

Loss of charge and oil pressure switch tests show LOW if the switch is open and NRM or SAFE if the switch is closed. The input channel can be tested by disconnecting the switch and using a jumper to simulate a closed or open circuit. (See Fig. 5.)

Note that the switch is read by the processor periodically, not continuously. When the switch position is changed, it may take a few seconds before the display changes.

The **2 TEST** subfunction will energize the control outputs except for the compressor control outputs. (See Fig. 6.)

The liquid line solenoid and unloader solenoid tests will energize the output when **ENTR** is pressed. It will remain energized until either the **↓** key is pressed or 10 minutes have elapsed. When the processor energizes the output relay it will display the word ON on the right side of the display.

The EXV open and close tests drive the EXV fully open or fully closed. See The EXV Checkout Procedure for more information. The display will read either zero steps open or 760 steps open.

The **3 TEST** subfunction energizes the compressor control relays for 10 seconds and displays the compressor status feedback.

The liquid line solenoid in the same circuit will energize for 10 seconds and the EXV will open 180 steps, then close.

When control power reaches the compressor control relay it also reaches the feedback terminal on terminal strip 233 (see Fig. 7). When this occurs the display will switch from OFF to UN. If the display changes but the compressor does not start, check the control relay, contactor, compressor circuit breaker, interconnecting wiring, and the compressor motor.

If the display does not change, check the discharge gas thermostat, high-pressure switch, condenser fan overload (on 30HS, if used), continuity across the DSIO terminals and interconnecting wiring.

To protect the compressors from repeated cycling, a delay of one minute is required before the same compressor is retested.

The **4 TEST** subfunctions take the unit out of the Quick Test mode. Press **4 TEST** and the display will show END TEST; press **ENTR** and the display blinks and then shows END TEST again.

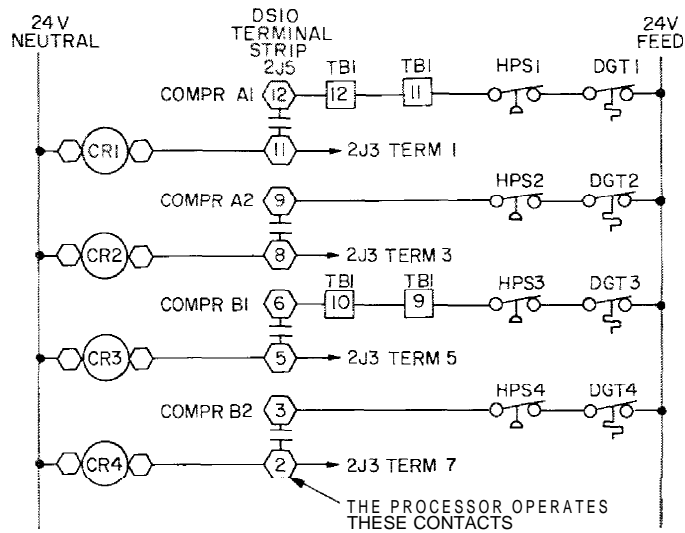

**Fig. 5 Compressor 24-V Control Circuit Wiring (Simplified)**

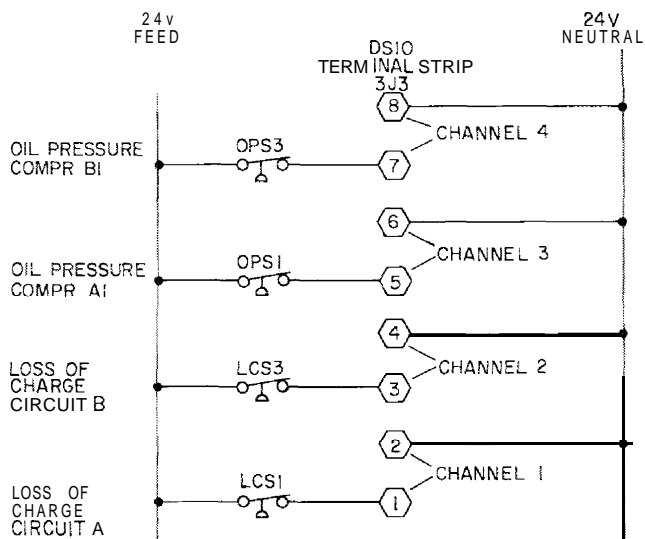

**Fig. 6 Pressure Feedback Circuit Wiring (Simplified)**

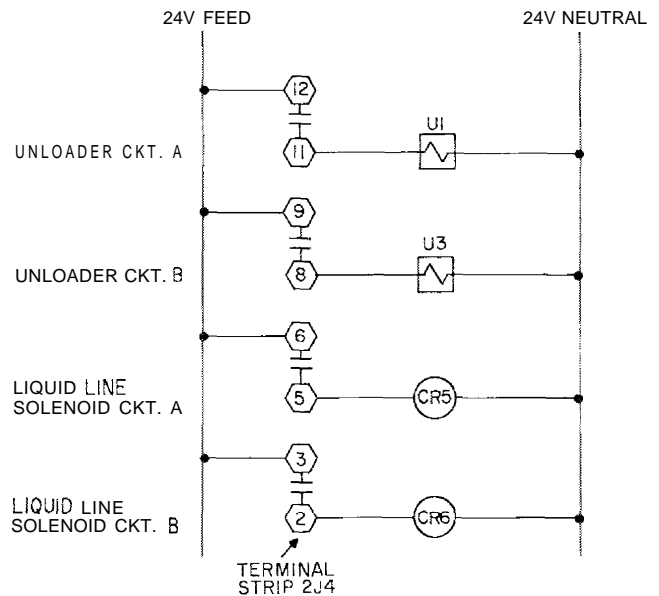

**Fig. 7 — Auxiliary Components 24-V Control Circuit Wiring (Simplified)**



Table 8a — Thermistor Temperature vs Resistance and Voltage (English)

TEMPERATURE (F)	VOLTAGE DROP (V)	RESISTANCE (OHMS)	TEMPERATURE (F)	VOLTAGE DROP (V)	RESISTANCE (OHMS)
-25.0	4.821	98009.6	58.0	3.464	8076.1
-24.0	4.818	94707.1	59.0	3.437	7867.7
-23.0	4.814	91521.5	60.0	3.409	7665.1
-22.0	4.806	88448.9	61.0	3.382	7468.3
-21.0	4.800	85485.5	62.0	3.353	7277.1
-20.0	4.793	82627.2	63.0	3.323	7091.2
-19.0	4.786	79870.6	64.0	3.295	69106
-18.0	4.779	77212.0	65.0	3.267	6735.1
-17.0	4.772	74647.9	66.0	3.238	6564.4
-16.0	4.764	72175.1	67.0	3.210	6398.6
-15.0	4.757	69790.3	68.0	3.184	6237.5
-14.0	4.749	67490.4	69.0	3.152	6080.8
-13.0	4.740	65272.4	70.0	3.123	5928.6
-12.0	4.734	63133.3	71.0	3.093	5780.6
-11.0	4.724	61070.3	72.0	3.064	5636.8
-10.0	4.715	59080.6	73.0	3.034	5497.0
-9.0	4.705	57161.7	74.0	3.005	5361.2
-8.0	4.696	55310.9	75.0	2.977	5229.1
-7.0	4.688	53525.8	76.0	2.947	5100.8
-6.0	4.676	51804.0	77.0	2.917	4976.0
-5.0	4.666	50143.2	78.0	2.884	4854.8
-4.0	4.657	48541.1	79.0	2.857	4736.9
-3.0	4.648	46995.6	80.0	2.827	4622.4
-2.0	4.636	45504.7	81.0	2.797	4511.1
-1.0	4.624	44066.3	82.0	2.766	4402.9
0.0	4.613	42678.5	83.0	2.738	4297.7
1.0	4.602	41339.3	84.0	2.708	4195.5
2.0	4.592	40047.1	85.0	2.679	4096.1
3.0	4.579	38800.0	86.0	2.650	3999.6
4.0	4.567	37596.4	87.0	2.622	3905.7
5.0	4.554	36434.7	88.0	2.593	3814.4
6.0	4.540	35313.3	89.0	2.563	3725.8
7.0	4.527	34230.7	90.0	2.533	3639.5
8.0	4.514	33185.4	91.0	2.505	3555.7
9.0	4.501	32176.2	92.0	2.476	3474.2
10.0	4.487	31201.5	93.0	2.447	3395.0
11.0	4.472	30260.1	94.0	2.417	3318.0
12.0	4.457	29350.9	95.0	2.388	3243.1
13.0	4.442	28472.5	96.0	2.360	3170.3
14.0	4.427	27623.8	97.0	2.332	3099.4
15.0	4.413	26803.7	98.0	2.305	3030.5
16.0	4.397	26011.2	99.0	2.277	2963.5
17.0	4.381	25245.1	100.0	2.251	2898.4
18.0	4.366	24504.6	101.0	2.217	2834.9
19.0	4.348	23788.7	102.0	2.189	2773.2
20.0	4.330	23096.4	103.0	2.162	2713.1
21.0	4.313	22426.9	104.0	2.136	2654.7
22.0	4.295	21779.3	105.0	2.107	2597.8
23.0	4.278	21152.8	106.0	2.080	2542.3
24.0	4.258	20546.7	107.0	2.053	2488.3
25.0	4.241	19960.2	108.0	2.028	2435.8
26.0	4.223	19392.5	109.0	2.001	2384.5
27.0	4.202	18843.0	110.0	1.973	2334.6
28.0	4.184	18311.0	111.0	1.946	2285.9
29.0	4.165	17795.8	112.0	1.919	2238.5
30.0	4.145	17297.0	113.0	1.897	2192.2
31.0	4.125	16813.8	114.0	1.870	2147.0
32.0	4.103	16345.7	115.0	1.846	2103.0
33.0	4.082	15892.2	116.0	1.822	2060.0
34.0	4.059	15452.7	117.0	1.792	2018.0
35.0	4.037	15026.7	118.0	1.771	1977.0
36.0	4.017	14613.9	119.0	1.748	1936.9
37.0	3.994	14213.6	120.0	1.724	1897.8
38.0	3.968	13825.5	121.0	1.702	1859.5
39.0	3.948	13449.2	122.0	1.676	1822.1
40.0	3.927	13084.2	123.0	1.653	1785.5
41.0	3.902	12730.1	124.0	1.630	1749.7
42.0	3.878	12386.6	125.0	1.607	1714.7
43.0	3.854	120533	126.0	1.585	1680.4
44.0	3.828	11730.0	127.0	1.562	1646.8
45.0	3.805	11416.1	128.0	1.538	1613.8
46.0	3.781	11111.5	129.0	1.517	1581.6
47.0	3.757	10815.8	130.0	1.496	1550.0
48.0	3.729	10528.7	131.0	1.474	1519.0
49.0	3.705	10250.0	132.0	1.453	1488.6
50.0	3.679	9979.3	133.0	1.431	1458.8
51.0	3.653	9716.5	134.0	1.408	1429.6
52.0	3.627	9461.3	135.0	1.389	1400.9
53.0	3.600	9213.4	136.0	1.369	1372.7
54.0	3.575	8972.6	137.0	1.348	1345.1
55.0	3.547	8738.6	138.0	1.327	1318.0
56.0	3.520	8511.4	139.0	1.308	1291.3
57.0	3.493	8290.6	140.0	1.291	1265.2

Table 8b — Thermistor Temperature vs Resistance and Voltage (SI)

TEMPERATURE (C)	VOLTAGE	RESISTANCE (Kohms)
-40	4.8961	166.23
-39	4.8892	157.44
-38	4.88177	147.41
-37	4.874	138.09
-36	4.86577	129.41
-35	4.85709	121.33
-34	4.84793	113.81
-33	4.83839	106.88
-32	4.82808	100.26
-31	4.81736	94.165
-30	4.80608	88.48
-29	4.79421	83.17
-28	4.78151	78.125
-27	4.76863	73.58
-26	4.75488	69.25
-25	4.74046	65.205
-24	4.72534	61.42
-23	4.7095	57.875
-22	4.6929	54.555
-21	4.67557	51.45
-20	4.65743	48.536
-19	4.6365	45.807
-18	4.61873	43.247
-17	4.59811	40.845
-16	4.57663	38.592
-15	4.55426	36.476
-14	4.53099	34.489
-13	4.50678	32.621
-12	4.48165	30.866
-11	4.45556	29.216
-10	4.42794	27.633
-9	4.40044	26.202
-8	4.37141	24.827
-7	4.34138	23.532
-6	4.31036	22.313
-5	4.27829	21.163
-4	4.24521	20.079
-3	4.21115	19.058
-2	4.17605	18.094
-1	4.13993	17.184
0	4.10279	16.325
1	4.06471	15.515
2	4.0256	14.749
3	3.98557	14.026
4	3.94454	13.342
5	3.90262	12.696
6	3.85979	12.085
7	3.816	11.506
8	3.77142	10.959
9	3.726	10.441
10	3.67969	9.9495
11	3.63271	9.485
12	3.58496	9.0445
13	3.53653	8.627
14	3.48742	8.237
15	3.43771	7.8555

TEMPERATURE (C)	VOLTAGE	RESISTANCE (Kohms)
16	3.38739	7.499
17	3.3366	7.161
18	3.2853	6.84
19	3.23369	6.5358
20	3.18154	6.246
21	3.12913	5.971
22	3.07641	5.7095
23	3.02348	5.461
24	2.97044	5.225
25	2.91715	
26	2.86384	4.7861
27	2.81049	4.5825
28	2.75717	4.3887
29	2.70394	4.2042
30	2.65082	4.0284
31	2.59787	3.8609
32	2.54514	3.7013
33	2.4927	3.5492
34	2.44053	3.4041
35	2.38871	3.2657
36	2.33733	3.1338
37	2.28633	3.0078
38	2.23582	2.8876
39	2.18579	2.7728
40	2.1363	2.6632
41	2.08738	2.5585
42	2.03907	2.4585
43	1.99135	2.3629
44	1.94433	2.2716
45	1.89792	2.1842
46	1.85224	2.1007
47	1.80726	2.0208
48	1.76302	1.9444
49	1.71947	1.8712
50	1.67672	1.8012
51	1.63474	1.7342
52	1.59351	1.67
53	1.55306	1.6085
54	1.51333	1.5495
55	1.47449	1.4931
56	1.43642	1.439
57	1.39911	1.3871
58	1.36264	1.3374
59	1.32693	1.2897
60	1.29199	1.2439
61	1.25786	1.2
62	1.22454	1.1579
63	1.192	1.1175
64	1.16014	1.0786
65	1.12916	1.0414
66	1.09887	1.0056
67	1.06889	.9707
68	1.04046	.9381
69	1.01238	.90635
70	.984975	.8758

## Electronic Expansion Valves

**CHECKOUT PROCEDURE** Follow steps below to diagnose and correct EXV problems. For an explanation of EXV operation, see page 21.

**Step 1 Check EXV Driver Outputs** — Check EXV output signals at appropriate terminals on the EXV driver module (Fig. 8) as follows:

Connect positive test lead to terminal 1 on EXV driver. Set meter for approximately 20 vdc. Enter outputs sub-

function of test function by pressing **2** **TEST**, then

advance to EXVA Open Quick Test by pressing **↓** 5

times. Press **ENTR**. The driver should drive the EXV fully

open. During the next several seconds connect the negative test lead to pins 2, 3, 4 and 5 in succession. Voltage should rise and fall at each pin. If it remains constant at a voltage or at zero volts, remove the connector to the valve

and recheck. Press **↓** to reach the EXV A Close Quick

Test. If a problem still exists, replace the EXV driver. If the voltage reading is correct, the expansion valve should be checked. Next, test EXVB. Connect the positive test lead to pin 7 and the negative to pin 8, 9, 10, 11 in succession during the EXVB Quick Test.

**Step 2 Check EXV Wiring** — Check wiring to electronic expansion valves from terminal strip on EXV driver (Fig. 8).

1. Check color coding and wire connections. Make sure they are connected to correct terminals at driver and EXV plug connections.

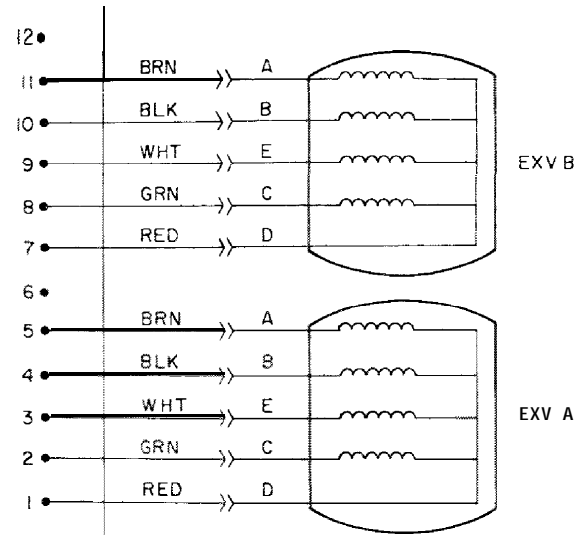

**Fig. 8 — EXV Cable Connections to EXV Driver Module**

2. Check for continuity and tight connection at all pin terminals.
3. Check plug connections at driver and at EXVs. Be sure EXV connections are not crossed.

**Step 3 Check Resistance of EXV Motor Windings**  
Remove plug at J7 terminal strip and check resistance between common lead (red wire, terminal D) and remaining leads A, B, C, and E (see Fig. 8). Resistance should be **25 ohms +/- 2 ohms**.

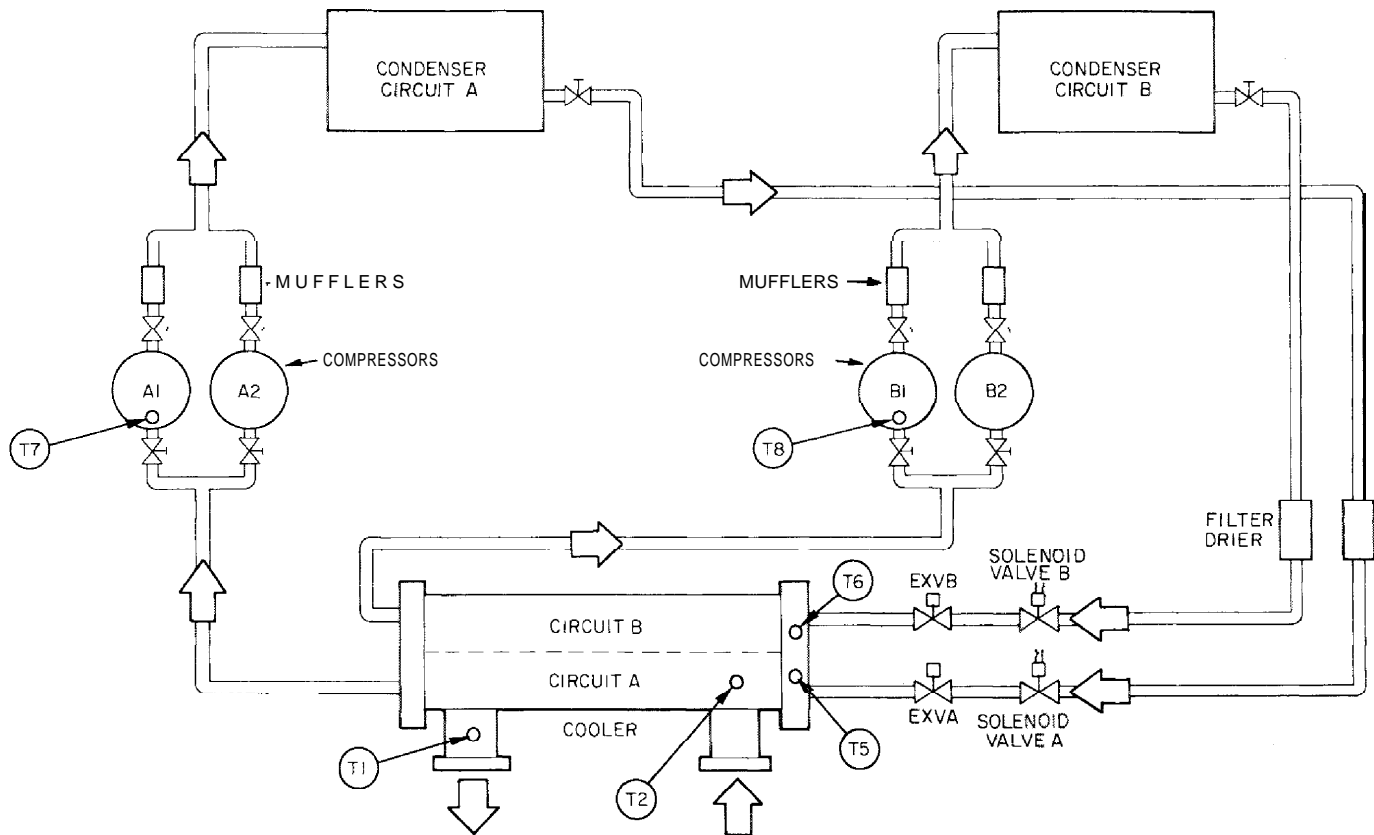

**Fig. 9 — Thermistor Locations**

**Step 4 — Check Thermistors That Control EXV**

Check thermistors that control processor output voltage pulses to EXVs. Circuit A thermistors are T5 and T7. Circuit B thermistors are T6 and T8. Refer to Fig. 9 for location.

1. Use the temperature subfunction of the status function (   ) to determine if thermistors are reading correctly.
2. Check thermistor calibration at known temperature by measuring actual resistance and comparing value measured with values listed in Table 8.
3. Make sure that thermistor leads are connected to proper pin terminals at 157 terminal strip on processor module and that thermistor probes are located in proper position in refrigerant circuit (Fig. 9).

When above checks have been completed, actual operation of EXV can be checked by using procedures outlined in Step 5.

**Step 5 Check Operation of the EXV** Use following procedure to check actual operation of electronic expansion valves.

1. Close liquid line service valve for circuit to be checked and run through the Quick Test step (in subfunction 3 of test function) for the lead compressor in that circuit to pump down the low side of the system. Repeat test step 3 times to ensure that all refrigerant has been pumped from low side.

NOTE: Be sure to allow compressors to run full 10 seconds at each step.

2. Turn OFF compressor circuit breaker(s). Close compressor service valves and vent any remaining refrigerant from low side of system.

3. Remove screws holding top cover of EXV. Carefully remove top cover, using caution to avoid damage to the motor leads. If EXV plug was disconnected during this process, reconnect it after the cover is removed.
4. Enter appropriate EXV Quick Test step for EVXA or EXVB in the outputs subfunction of the test function (   ). Press **ENTR** to initiate test. With cover

lifted off the EXV valve body, observe operation of valve motor and lead screw. The motor should turn in the clockwise direction and the lead screw should move down into the motor hub until the valve is fully closed or fully open depending on whether you initiate the open or close test step for that valve. Lead screw movement should be smooth and uniform from fully open to fully closed position, or from fully closed to fully open.

If valve is properly connected to processor and receiving correct signals, yet does not operate as described above, the valve should be replaced.

The operation of the EXV valve can also be checked without removing the top cover. This method depends on the operator's skill in determining whether or not the valve is moving. To use this method, initiate the Quick Test to open the valve. Immediately grasp the EXV valve body with the hand. As the valve drives open, a soft, smooth pulse will be felt for approximately 26 seconds as the valve travels from fully closed to fully open. When the valve reaches the end of its opening stroke, a hard pulse will be felt momentarily. Drive the valve closed and a soft, smooth pulse will be felt for the 26 seconds necessary for the valve to travel from fully open to fully closed. When the valve reaches the end of its stroke, a hard pulse will again be felt as the valve overdrives by 50 steps. The valve should be driven through at least 2 complete cycles to be sure it is operating properly. If a hard pulse is felt for the 26 second duration, the valve is not moving and should be replaced.

The EXV test can be repeated as required by pressing

**ENTR** to start the test.

If operating problems persist after reassembly, they may be due to out-of-calibration thermistor(s), or intermittent connections between processor board terminals and EXV plug. Recheck all wiring connections and voltage signals.

Other possible causes of improper refrigerant flow control could be restrictions in liquid line. Check for plugged filter drier(s), stuck liquid line solenoid valve(s) or restricted metering slots in the EXV. Formation of ice or frost on lower body of electronic expansion valve is *one* symptom of restricted metering slots. Clean or replace valve if necessary.

NOTE: Frosting of valve is normal during compressor Quick Test steps and at initial start-up. Frost should dissipate after 5 to 10 minutes operation of a system that is operating properly. If valve is to be replaced, wrap valve with a wet cloth to prevent excessive heat from damaging internal components.

EXV OPERATION — These valves control the flow of liquid refrigerant into the cooler. They are operated by the processor to maintain 20 degrees F of superheat between the cooler entering refrigerant thermistor and the lead compressor entering gas thermistor (located between the compressor motor and the cylinders). There is one EXV per circuit. A cutaway drawing of valve is shown in Fig. 10.

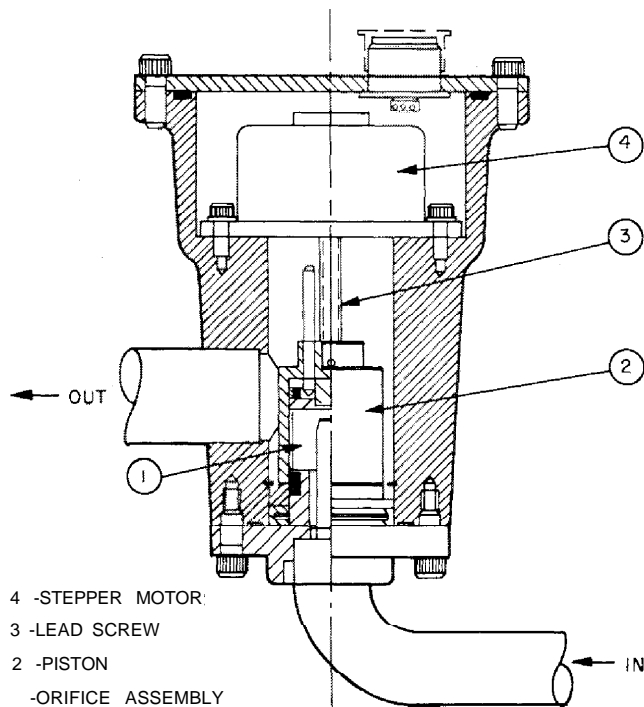

Fig. 10 — Electronic Expansion Valve

High-pressure liquid refrigerant enters valve through bottom. A series of calibrated slots have been machined in side of orifice assembly. As refrigerant passes through orifice, pressure drops and refrigerant changes to a 2-

phase condition (liquid and vapor). To control refrigerant flow for different operating conditions, piston moves up and down over orifice, thereby changing orifice size. Piston is moved by a linear stepper motor. Stepper motor moves in increments and is controlled directly by processor module. As stepper motor rotates, motion is transferred into linear movement by lead screw. Through stepper motor and lead screws, 760 discrete steps of motion are obtained. The large number of steps and long stroke results in very accurate control of refrigerant flow.

Control of valve is by microprocessor. Two thermistor temperature sensors are used to determine superheat. One thermistor is located in the cooler and the other is located in the passage between the compressor motor and cylinders. The difference between the 2 temperatures controls superheat. On a normal TXV system, superheat leaving evaporator is normally 10 F (5.6 C) and motor then adds approximately 15 to 20 degrees F (8 to 11 degrees C) resulting in approximately 30 F (16.7 C) superheat entering cylinders. The EXV controls superheat entering cylinders to approximately 20 F (11 C). Thus superheat leaving cooler is approximately 3 F to 5 F (2 C to 3 C), or less.

Because the EXVs are controlled by the processor module, it is possible to track valve position. During initial start-up, EXV is fully closed. After start-up, valve position is tracked by processor by constantly observing amount of valve movement.

The processor keeps track of the EXV position by counting the number of open and closed steps it has sent to each valve. It has no direct physical feedback of valve position. Whenever the unit is switched from STANDBY to RUN, both valves will be initialized. This means the processor will send enough closing pulses to the valve to move it from fully open to fully closed and then reset the position counter to zero.

The EXV open Quick Tests will send enough pulses to the valve to drive it from fully closed to fully open. The position of the valve at the start of the test has no effect on the number of pulses sent.

In the same manner, the EXV close Quick Tests will send enough pulses to the valve to drive it from fully open to fully closed.

When the EXV opens, the metering slots are not uncovered until step 160. This is fully closed position when the circuit is operating. The fully open position is 760 steps.

The **7 STAT** subfunction shows the EXV valve positions. They should change constantly while the unit operates. If a valve should stop moving for any reason (mechanical or electrical) other than a processor or thermistor failure, the processor will continue to attempt to open or close the valve to correct the superheat. Once the calculated valve position reaches 160 (fully closed) or 760 (fully open) it will remain there. If the EXV position reading remains at 160 or 760 and the cooler and compressor refrigerant thermistor displays are reading the measured temperature correctly, the EXV is not moving. Follow the EXV checkout procedure to determine the cause.

The EXV is also used to limit cooler suction temperature to 55 F (13 C). This makes it possible for the chiller to start at higher cooler water temperatures without overloading compressor. This is commonly referred to as MOP (maximum operating pressure).

**Thermistors** — All thermistors are identical in their temperature vs resistance performance. Resistance at various temperatures are listed in Table 8.

**LOCATION** -- General location of thermistor sensors are shown in Fig. 9.

Cooler Leaving Water Sensor, T1, is located in the leaving water nozzle. The probe is immersed directly in the water. All thermistor connections are made through a 1/4-in. coupling (Fig. I I). Actual location is shown in Fig. 4.

Cooler Entering Water Sensor, T2, is located in the cooler shell in first baffle space, near to tube bundle. Actual location is shown in Fig. 4.

Cooler Saturated Suction Temperature Sensors, T5 and T6, are located next to refrigerant inlet in cooler head. Thermistors are immersed directly into refrigerant. Typical location is shown in Fig. 4.

Compressor Suction Gas Temperature Sensors, T7 and T8, are located in lead compressor in each circuit in a suction passage between motor and cylinders, above oil pump.

**SENSOR REPLACEMENT** — T1, T2, T5, T6, T7, T8 (Compressor and Cooler)

**CAUTION**

Sensors are installed directly in refrigerant or water circuit. Relieve all refrigerant pressure or drain water before removing.

Proceed as follows (refer to Fig. I I):

1. Remove and discard original sensor and coupling.

**IMPORTANT:** Do not disassemble new coupling; install as received.

2. Apply pipe sealant to 1/4-in. NPT threads on replacement coupling and install in place of original. Do not use packing nut to tighten coupling; this would damage ferrules (see Fig. I I ).
3. Insert new sensor in coupling body to its full depth. Hand tighten packing nut to position ferrules, then finish tightening 1-1/4 turns with a suitable tool. Ferrules are now attached to sensor, which can be withdrawn from coupling for unit servicing.

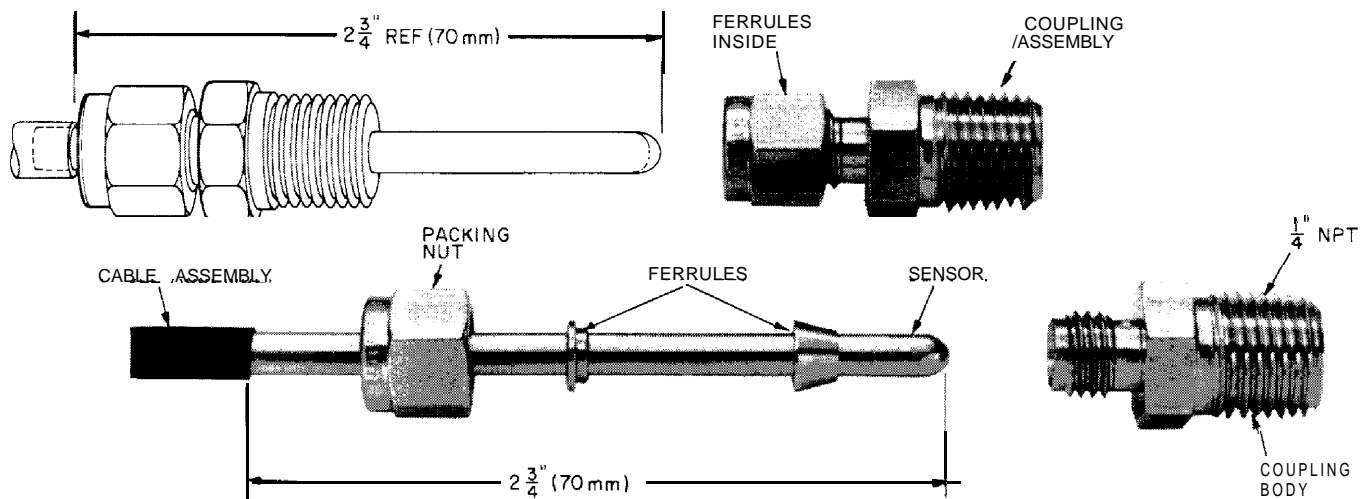

**Fig. 11 — Thermistor (Compressor and Cooler)**

## Modules

### ▲ CAUT.

Turn controller power off before servicing the controls. This is to ensure safety and prevent damage to the controller.

**PROCESSOR MODULE (PSIO), LOW-VOLTAGE RELAY MODULE (DSIO) AND EXV DRIVER MODULE (DSIO)** — The PSIO and DSIO modules all perform continuous diagnostic evaluations of the condition of the hardware. Proper operation of these modules is indicated by LEDs (light emitting diodes) on the front surface of the DSIOs and on the top horizontal surface of the PSIO.

#### Red LED:

*Blinking continuously* at a 3 to 5 second rate indicates proper operation

*Lit continuously* indicates a problem requiring replacement of the module

*Off continuously* indicates the power should be checked. If there is no input power, check fuses. If fuse is bad, check for shorted secondary of transformer, or for bad module.

Green LED: (On a PSIO, this is the green LED closest to the COMM connectors. The other green LED on the module indicates external communications, when used.)

The green LED should always be blinking when power is on; it indicates that the modules are communicating properly. If a green LED is not blinking, check the red LED. If the red LED is normal, check the module address switches. See Fig. 9. The proper addresses are:

PSIO (Processor Module) — 00  
DSIO (Relay Module) 32  
DSIO (EXV Driver Module) -- 50

If all modules indicate a communication failure, check the COMMplug on the PSIO module for proper seating. If a good connection is assured and the condition persists, replace the PSIO module.

If only a DSIO module indicates a communication failure, check the COMM plug on that module for proper seating. If a good connection is assured and the condition persists, replace the DSIO module.

All system operating intelligence rests in the PSIO module (processor module), the module that controls the unit. This module monitors conditions through input and output ports and through the DSIO modules (low-voltage relay module and EXV driver module).

The machine operator communicates with the micro-processor through the HSIO module (keyboard/display module). Communication between the PSIO and the other modules is accomplished by a 3-wire sensor bus. These 3 wires run in parallel from module to module. Each module in a panel is numbered (1, 2, 3...). Each terminal strip on a module is labeled (J2, J3, J4...). The terminal strip number on the machine schematic combines the module and strip numbers. For example, 2J3 is terminal strip J3 on module 2. The module numbers can be found on the component arrangement label.

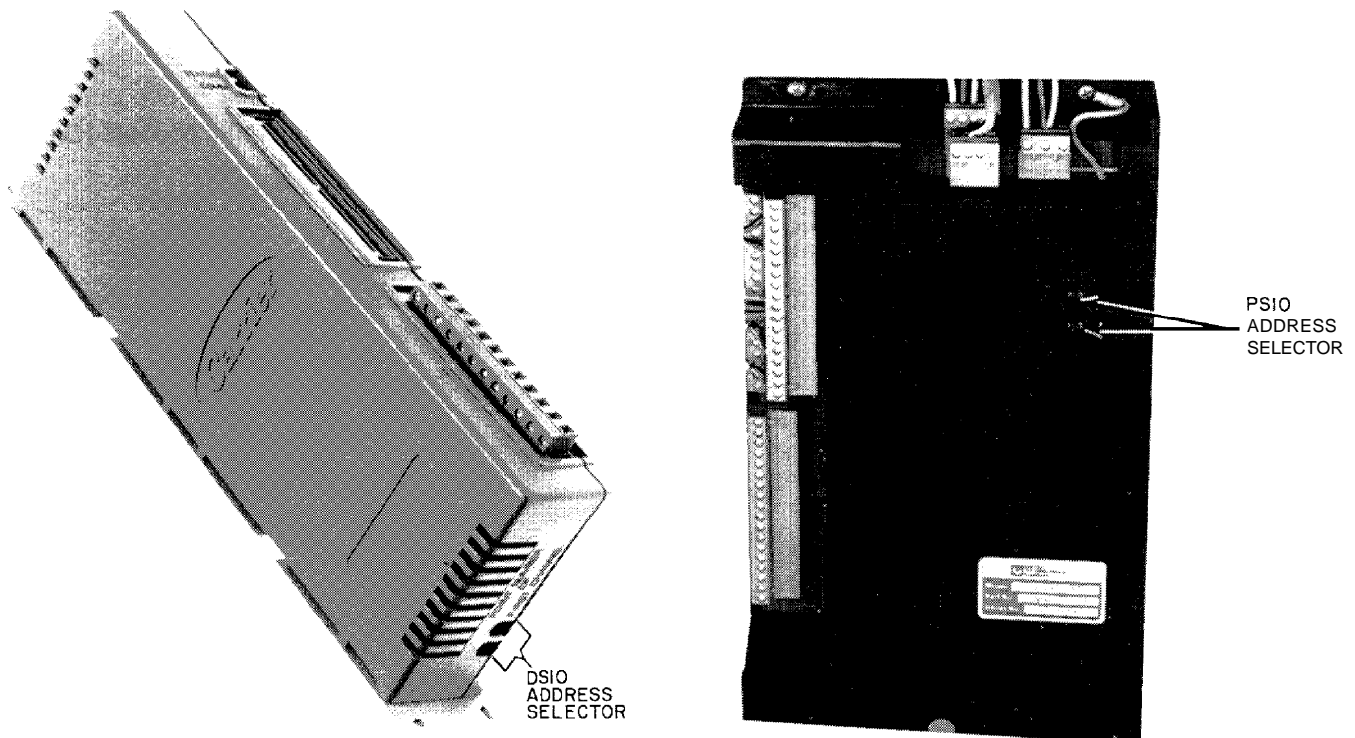

Fig. 12 — Module Address Selector Switch Locations

On the sensor bus terminal strips, terminal 1 of the PSIO module is connected to terminal 1 of each of the other modules; terminals 2 and 3 are connected in the same manner. (See Fig. 13.) If a terminal 2 wire is connected to terminal 1, the system will not work.

In the 30HR,HS units, the processor module, low-voltage relay module, and keyboard display module are all powered from a common 21 vac power source which connects to terminals 1 and 2 on the power input strip of each module. A separate source of 12.5 vac power is used to power the EXV driver module through terminals 1 and 2 on the power input strip.

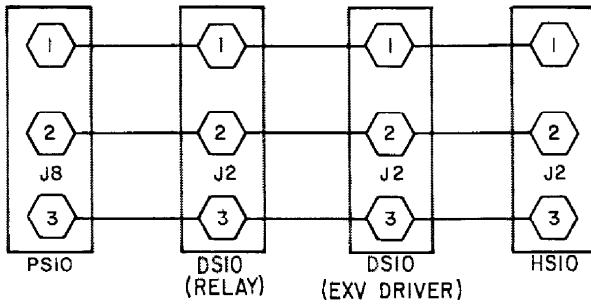

Fig. 13 Sensor Bus Wiring

Processor Module (PSIO) (Fig. 14.)

**Inputs** — Each input channel has 3 terminals; only 2 of the 3 terminals are used. The application of the machine determines which terminals are used. Always refer to the individual unit wiring for terminal numbers.

**Outputs** Output is 24 vdc. Again, there are 3 terminals, only 2 of which are used; which 2 depends on the application. Refer to unit wiring diagram.

NOTE: Both address switches must be set at zero.

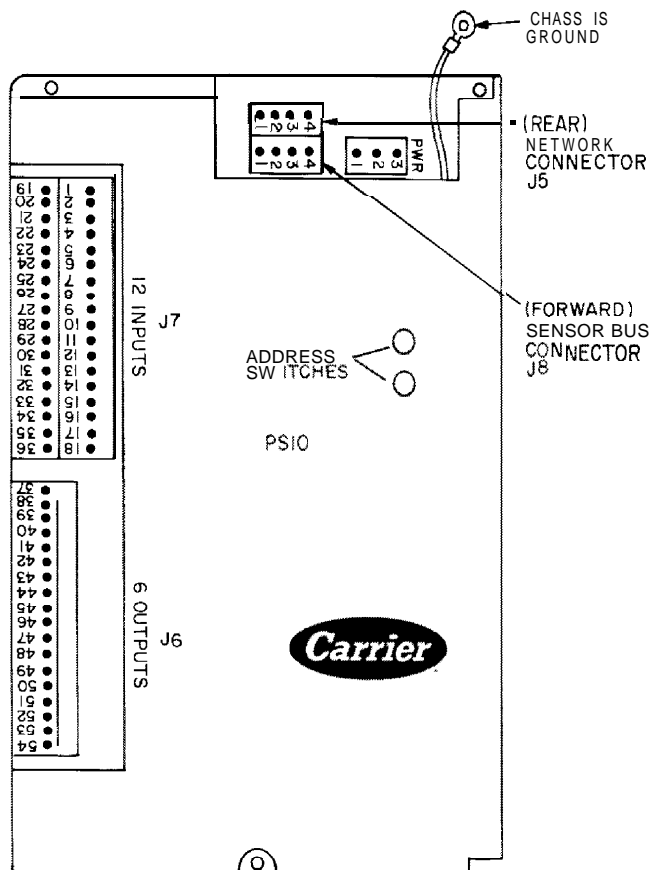

Fig. 14 Processor Module (PSIO)

Low-Voltage Relay Module (DSIO) (Fig. 15.)

**Inputs** - - Inputs on strip J3 are discrete inputs (ON-OFF). When 24 vac are applied across the 2 terminals in a channel it is read as an ON signal, Zero volts is read as an OFF signal.

**Outputs** Terminal strips J4 and J5 are internal relays whose coils are powered-up and powered-off by a signal from the microprocessor. The relays switch the circuit to which they are connected. No power is supplied to these connections by the DSIO module.

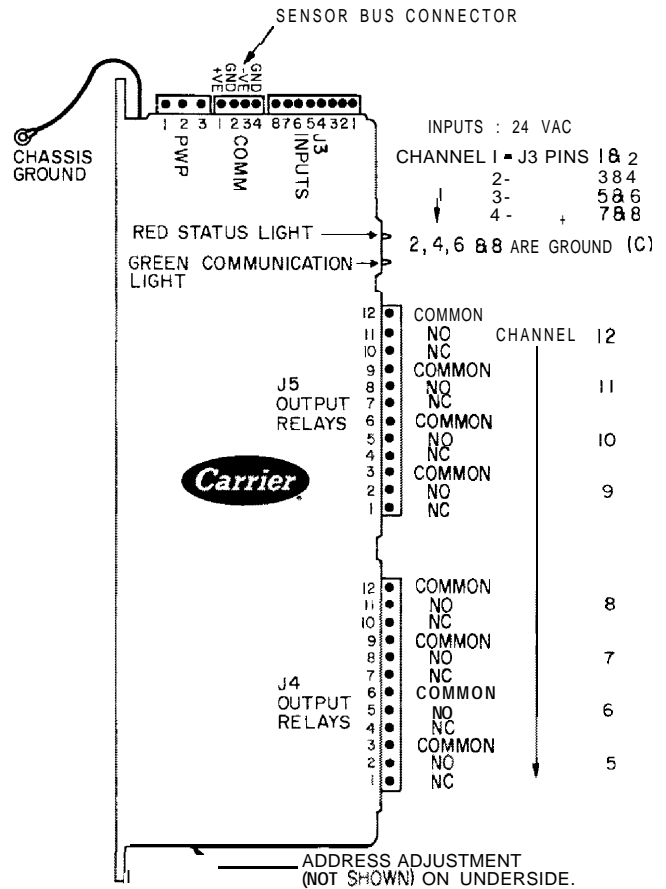

Fig. 15 — Low-Voltage Relay Module (DSIO)



**EXV Driver Module (Fig. 16.)**

**Inputs** — Input on strip J3 am-c discrete inputs (ON-OFF). When 24 vac are applied across the 2 terminals in a channel it is read as an ON signal. Zero volts is read as an OFF signal.

**Outputs** Two stepper motor driver outputs are used to drive the electronic expansion valves, Terminals 1 and 7 supply voltage to the valves. Terminals 2 through 5 and 8 through 11 connect the individual coils (4 per valve) to neutral in a repeating sequence to drive the valves in incremental steps.

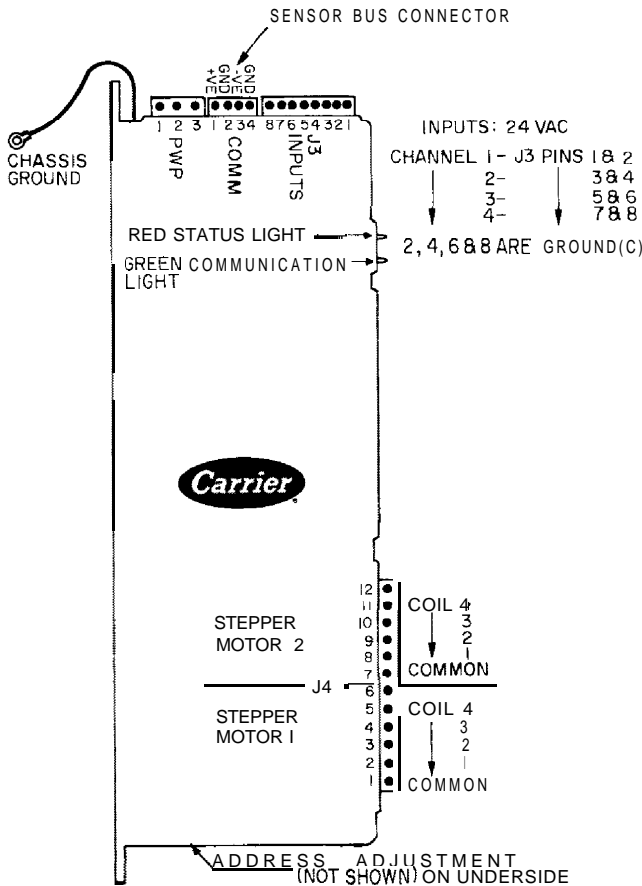

**Fig. 16 — EXV Driver Module (DSIO)**

**Keyboard/ Display Module (HSIO) (Fig. 17)** The only function of the HSIO is to allow the operator to communicate with the processor. It is used to enter configurations and set points and to read data, perform tests and set schedules.

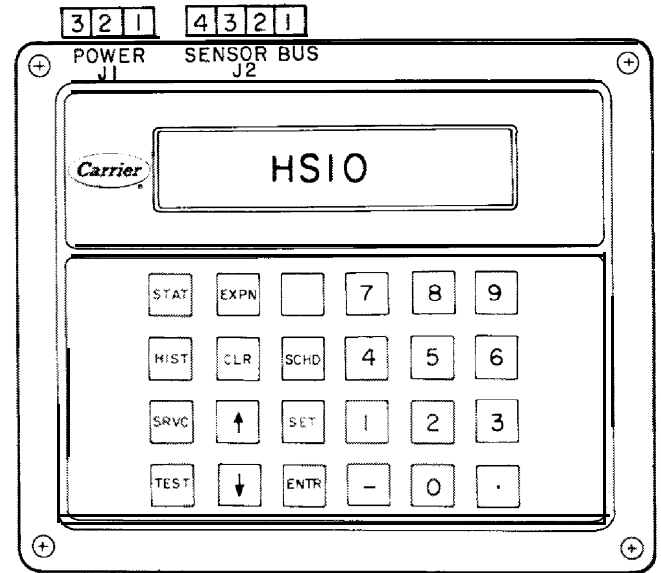

**Fig. 17 Keyboard/Display Module (HSIO)**

## TROUBLESHOOTING

SYMPTOMS	CAUSE:	REMEDY:
<b>Compressor does not run</b>	Power line open	Reset circuit breaker.
	Control fuse open	Check control circuit for ground or short. Replace fuse.
	Safety thermostat tripped (DGT)	Move RUN/STANDBY switch to STANDBY, then back to RUN.
	Tripped power breaker	Check the controls. Find cause of trip and reset breaker.
	Condenser circulating pump not running	Power off — restart.
		Pump binding — free pump.
		Incorrect wiring — rewire.
	Loose terminal connection	Pump motor burned out — replace.
		Check connections.
	Improperly wired controls	Check wiring and rewire.
Low line voltage	Check line voltage — determine location of voltage drop and remedy deficiency.	
Compressor motor defective	Check motor winding for open or short. Replace compressor, if necessary.	
Seized compressor	Replace compressor.	
<b>Compressor cycles off on loss of charge</b>	Loss of charge control erratic in action	Repair leak; recharge. Replace control.
	Low refrigerant charge	Add refrigerant.
<b>Compressor shuts down on high-pressure control</b>	High-pressure control erratic in action	Replace control.
	Compressor discharge valve partially closed	Open valve, or replace if defective.
	Air in system	Purge.
	Condenser scaled	Clean condenser.
	Receiver not properly vented refrigerant backs up into evap condenser	Repipe as required, providing adequate venting.
	Condenser water pump or fans not operating	Start pump— repair or replace if defective.

SYMPTOMS:	CAUSE	REMEDY
<b>Unit operates long or continuously</b>	Low refrigerant charge	Add refrigerant.
	Control contacts fused	Replace control.
	Air in system	Purge.
	Partially plugged or plugged expansion valve or filter drier	Clean or replace.
	Defective insulation	Replace or repair.
	Service load	Keep doors and windows closed.
<b>System Noises</b>	Inefficient compressor	Check valves, replace if necessary.
	Piping vibration	Support piping as required. Check for loose pipe connectors.
	Expansion valve hissing	Add refrigerant. Check for plugged liquid line filter drier.
	Compressor noisy	Check valve plates for valve noise. Replace compressor (worn bearings) Check for loose compressor hold-down bolts.
<b>Compressor loses oil</b>	Leak in system	Repair leak.
	Mechanical damage (blown piston or broken dish valve)	Repair damage or replace compressor.
	Oil trapped in line	Check piping for oil traps.
	Crankcase heaters not energized during shutdown	Replace heaters, check wiring and crankcase heater relay contacts.
<b>Frosted suction line</b>	Expansion valve admitting excess refrigerant	Check cooler and compressor thermistors; test EXV.
<b>Hot liquid line</b>	Shortage of refrigerant due to leak	Repair leak and recharge.
<b>Frosted liquid line</b>	Shutoff valve partially closed or restricted	Open valve or remove restriction.
	Restricted filter drier	Remove restriction or replace filter drier.
<b>Compressor will not unload</b>	Burned out coil	Replace coil.
	Defective capacity control valve	Replace valve.
	Miswired solenoid	Rewire correctly.
	Weak, broken or wrong valve body spring	Replace spring.
<b>Compressor will not load</b>	Miswired solenoid	Rewire correctly.
	Defective capacity control valve	Replace valve.
	Plugged strainer (high side)	Clean or replace strainer.
	Stuck or damaged unloader piston or piston ring(s)	Clean or replace the necessary parts.



Manufacturer reserves the right to discontinue, or change at any time, specifications or designs without notice and without incurring obligations.

Book 2  
Tab b | 55c

PC111

Catalog No. 533-030

Printed in U.S.A.

Form 30HR,HS-1T

Pg 28

I-89

Replaces: New

## Free Manuals Download Website

<http://myh66.com>

<http://usermanuals.us>

<http://www.somanuals.com>

<http://www.4manuals.cc>

<http://www.manual-lib.com>

<http://www.404manual.com>

<http://www.luxmanual.com>

<http://aubethermostatmanual.com>

Golf course search by state

<http://golfingnear.com>

Email search by domain

<http://emailbydomain.com>

Auto manuals search

<http://auto.somanuals.com>

TV manuals search

<http://tv.somanuals.com>