

Models 336, 338 & 339

Freezemaster 300 Series

Operating Instructions

036029-M



6/98

Complete this page for quick reference when service is required:

Taylor Distributor: _____

Address: _____

Phone: _____

Service: _____

Parts: _____

Date of Installation: _____

Information found on the data label:

Model Number: _____

Serial Number: _____

Electrical Specs: Voltage _____ Cycle _____

Phase _____

Maximum Fuse Size: _____ A

Minimum Wire Ampacity: _____ A

© June, 1998 Taylor
All rights reserved.
036029-M



*The word Taylor and the Crown design
are registered trademarks in the United States
of America and certain other countries.*

Taylor
a division of Carrier Commercial Refrigeration, Inc.
750 N. Blackhawk Blvd.
Rockton, IL 61072

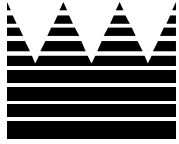

Table of Contents

Section 1	To the Installer	1
	Water Connections (Water Cooled Units Only)	1
	Air Cooled Units	1
	Electrical Connections	1
Section 2	To the Operator	2
	Compressor Warranty Disclaimer	2
Section 3	Safety	3
Section 4	Operator Parts Identification	4
	Model 336	4
	Model 338	5
	Model 339	6
	Three Spout Door	7
	Accessories	8
Section 5	Important: To the Operator	9
	Symbol Definitions	9
	Power Switch	10
	Indicator Light - "Mix Low"	10
	Mix Refrigeration Button	10
	"Standby"	10
	"Wash"	10
	"Auto"	10
	Reset Button	10
	Air Tube	11
	Adjustable Draw Handle	11
Section 6	Operating Procedures	12
	Assembly	12
	Sanitizing	16
	Priming	18
	Closing Procedure	19
	Draining Product From The Freezing Cylinder	19
	Rinsing	19
	Cleaning	20
	Disassembly	20
	Brush Cleaning	20

Section 7	Important: Operator Checklist	22
	During Cleaning and Sanitizing	22
	Troubleshooting Bacterial Count	22
	Regular Maintenance Checks	22
	Winter Storage	23
Section 8	Troubleshooting Guide	24
Section 9	Parts Replacement Schedule	27
Section 10	Parts List	28
	Wiring Diagrams	36

Note: Continuing research results in steady improvements; therefore, information in this manual is subject to change without notice.

Section 1

To the Installer

These machines are designed for indoor use only.



DO NOT install the machines in an area where a water jet could be used. Failure to follow this instruction may result in serious electrical shock.

Water Connections (Water Cooled Units Only)

An adequate cold water supply must be provided with a hand shut-off valve. On the underside rear of the base pan, two 1/2" I.P.S. water connections for inlet and outlet have been provided for easy hook-up. 1/2" inside diameter water lines should be connected to the machine. (Flexible lines are recommended, if local codes permit.) Depending on local water conditions, it may be advisable to install a water strainer to prevent foreign substances from clogging the automatic water valve. There will be only one water "in" and one water "out" connection for both single-head and double-head units. **DO NOT** install a hand shut-off valve on the water "out" line! Water should always flow in this order: first, through the automatic water valve; second, through the condenser; and third, through the outlet fitting to an **open trap drain**.

Air Cooled Units

Air cooled units require a minimum of 3" (76 mm) of clearance around **all** sides of the freezer to allow for adequate air flow across the condenser(s). Failure to allow adequate clearance can reduce the refrigeration capacity of the freezer and possibly cause permanent damage to the compressor.

Electrical Connections

Each freezer requires one power supply for each data label. Check the data label(s) on the freezer for fuse, circuit ampacity and electrical specifications. Refer to the wiring diagram provided inside of the electrical box, for proper power connections.

In the United States, this equipment is intended to be installed in accordance with the National Electrical Code (NEC), ANSI/NFPA 70-1987. The purpose of the NEC code is the practical safeguarding of persons and property from hazards arising from the use of electricity. This code contains provisions considered necessary for safety. Compliance therewith and proper maintenance will result in an installation essentially free from hazard!

In all other areas of the world, equipment should be installed in accordance with the existing local codes. Please contact your local authorities.

Stationary appliances which are not equipped with a power cord and a plug or other device to disconnect the appliance from the power source must have an all-pole disconnecting device with a contact gap of at least 3 mm installed in the external installation.



CAUTION: THIS EQUIPMENT MUST BE PROPERLY GROUNDED! FAILURE TO DO SO CAN RESULT IN SEVERE PERSONAL INJURY FROM ELECTRICAL SHOCK!

Beater rotation must be clockwise as viewed looking into the freezing cylinder of any model freezer.

Note: The following procedures should be performed by a trained service technician.

To correct rotation on a three-phase unit, interchange any two incoming power supply lines at freezer main terminal block only.

To correct rotation on a single-phase unit, change the leads inside the beater motor. (Follow diagram printed on motor.)

Electrical connections are made directly to the terminal block provided in the main control box located behind the service panel.

Section 2

To the Operator

The freezer you have purchased has been carefully engineered and manufactured to give you dependable operation. The Taylor soft-serve models covered in this manual consist of the following: 336, 338 and 339.

These units, when properly operated and cared for, will produce a consistent quality product. Like all mechanical products, they will require cleaning and maintenance. A minimum amount of care and attention is necessary if the operating procedures outlined in this manual are followed closely.

This Operator's Manual should be read before operating or performing any maintenance on your equipment.

Your Taylor freezer will NOT eventually compensate for and correct any errors during the set-up or filling operations. Thus, the initial assembly and priming procedures are of extreme importance. It is strongly recommended that personnel responsible for the equipment's operation, both assembly and disassembly, go through these procedures together in order to be properly trained and to make sure that no confusion exists.

In the event you should require technical assistance, please contact your local authorized Taylor Distributor.



If the crossed out wheeled bin symbol is affixed to this product, it signifies that this product is compliant with the EU Directive as well as other similar legislation in effect after August 13, 2005. Therefore, it must be collected separately after its use is completed, and cannot be disposed as unsorted municipal waste.

The user is responsible for returning the product to the appropriate collection facility, as specified by your local code.

For additional information regarding applicable local laws, please contact the municipal facility and/or local distributor.

Compressor Warranty Disclaimer

The refrigeration compressor(s) on this machine are warranted for the term indicated on the warranty card accompanying this machine. However, due to the Montreal Protocol and the U.S. Clean Air Act Amendments of 1990, many new refrigerants are being tested and developed, thus seeking their way into the service industry. Some of these new refrigerants are being advertised as drop-in replacements for numerous applications. It should be noted that, in the event of ordinary service to this machine's refrigeration system, **only the refrigerant specified on the affixed data label should be used.** The unauthorized use of alternate refrigerants will void your compressor warranty. It will be the owner's responsibility to make this fact known to any technician he employs.

It should also be noted that Taylor does not warrant the refrigerant used in its equipment. For example, if the refrigerant is lost during the course of ordinary service to this machine, Taylor has no obligation to either supply or provide its replacement either at billable or unbillable terms. Taylor does have the obligation to recommend a suitable replacement if the original refrigerant is banned, obsoleted, or no longer available during the five year warranty of the compressor.

Taylor will continue to monitor the industry and test new alternates as they are being developed. Should a new alternate prove, through our testing, that it would be accepted as a drop-in replacement, then the above disclaimer would become null and void. To find out the current status of an alternate refrigerant as it relates to your compressor warranty, call the local Taylor Distributor or the Taylor Factory. Be prepared to provide the Model/Serial Number of the unit in question.

We at Taylor are concerned about the safety of the operator when he or she comes in contact with the freezer and its parts. Taylor has gone to extreme efforts to design and manufacture built-in safety features to protect both you and the service technician. As an example, warning labels have been attached to the freezer to further point out safety precautions to the operator.



IMPORTANT - Failure to adhere to the following safety precautions may result in severe personal injury or death. Failure to comply with these warnings may damage the machine and its components. Component damage will result in part replacement expense and service repair expense.

To Operate Safely:



DO NOT operate the freezer without reading this operator's manual. Failure to follow this instruction may result in equipment damage, poor freezer performance, health hazards, or personal injury.



- **DO NOT** operate the freezer unless it is properly grounded.
- **DO NOT** attempt any repairs unless the main power supply to the freezer has been disconnected.
- **DO NOT** operate the freezer with larger fuses than specified on the freezer data label.

Failure to follow these instructions may result in electrocution or damage to the machine. Contact your local authorized Taylor Distributor for service.



DO NOT use a water jet to clean or rinse the freezer. Failure to follow this instruction may result in serious electrical shock.



- **DO NOT** allow untrained personnel to operate this machine.
- **DO NOT** operate the freezer unless all service panels and access doors are restrained with screws.
- **DO NOT** remove the door, beater and blades, or drive shaft unless all control switches are in the OFF position.
- **DO NOT** put objects or fingers in door spout.

Failure to follow these instructions may result in contaminated product or severe personal injury to fingers or hands from hazardous moving parts.



USE EXTREME CAUTION when removing the beater assembly. The scraper blades are very sharp and may cause injury.



This freezer must be placed on a level surface. Failure to comply may result in personal injury or equipment damage.

DO NOT obstruct air intake and discharge openings: 3" (76 mm) minimum air space on sides and rear, and 7-1/2" (191 mm) on the bottom. The Model 338 requires 4-1/4" (108 mm) on the bottom.

Failure to follow this instruction may cause poor freezer performance and damage to the machine.

These freezers are designed to operate indoors, under normal ambient temperatures of 70°-75°F (21°-24°C). The freezers have successfully performed in high ambient temperatures of 104°F (40°C) at reduced capacities.

NOISE LEVEL: Airborne noise emission does not exceed 78 dB(A) when measured at a distance of 1.0 meter from the surface of the machine and at a height of 1.6 meters from the floor.

Section 4

Operator Parts Identification

Model 336

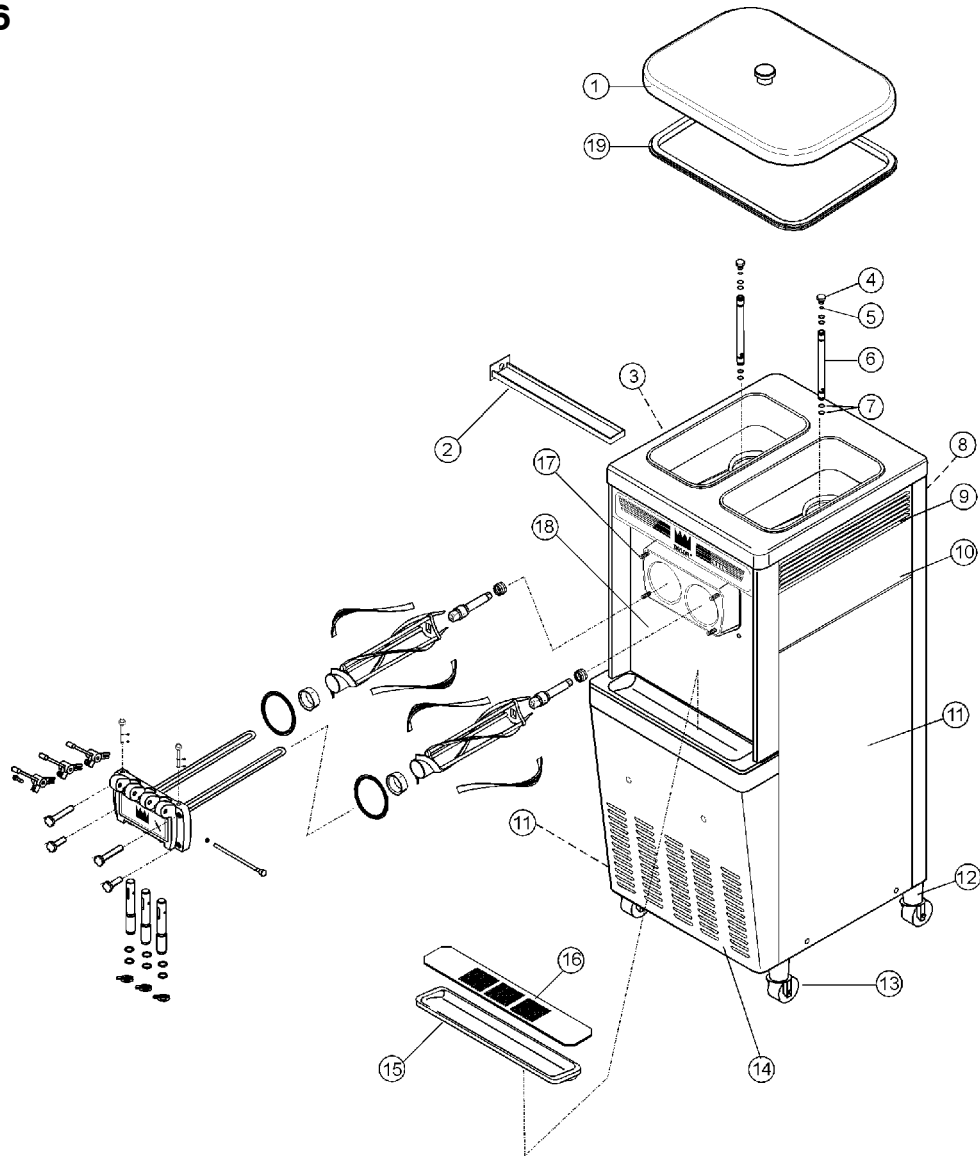

Item	Description	Part No.
1	Cover A.-Hopper	X37963
2	Pan-Drip 17-1/4" Long	027504
3	Panel-Upper Side Left	028740
4	Orifice	022465-100
5	O-Ring 3/8 OD x .070 W	016137
6	Tube-Feed 5/32 Dia. Hole	043461-2
7	O-Ring .563 OD x .070	043758
8	Panel-Rear	029816
9	Louver-Side (Right & Left)	017471
10	Panel-Upper Side Right	028741

Item	Description	Part No.
11	Panel A.-Lower Side (R & L)	X24424
12	Adaptor A.-Caster	X18915
13	Caster-Swivel 5/8 Stem 4" Wheel	018794
14	Panel-Service *336*	042824
15	Tray-Drip 16-7/8 L x 5-1/8	020157
16	Shield-Splash	022765
17	Stud-Nose	022822
18	Panel A.-Front	X42821-SP1
19	Gasket-Hopper Cover-8 Qt.	037042

Model 338

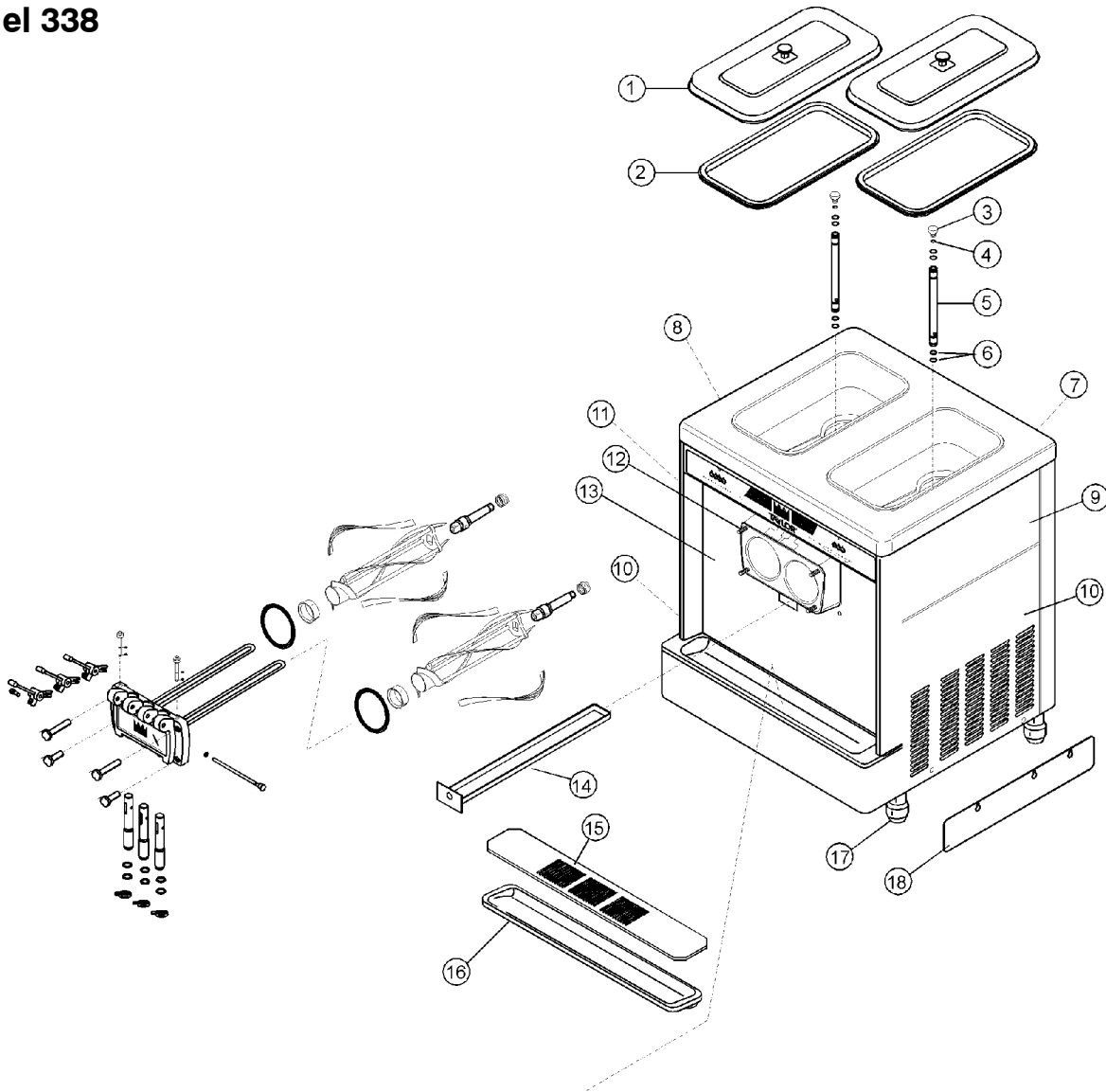

Item	Description	Part No.
1	Cover A.-Hopper-Standard	X38458
2	Gasket-Hopper Cover 20 Qt.	038474
3	Orifice	022465-100
4	O-Ring 3/8 OD x .070 W	016137
5	Tube A.-Feed SS 5/32 Hole	X29429-2
6	O-Ring .643 OD x .077 W	018572
7	Panel-Rear	051600
8	Louver-Side (Left)	017471
9	Panel A.-Side Upper Right	X48596

Item	Description	Part No.
10	Panel-Side (Lower Right)	048487
11	Panel A.-Side Left	X51596
12	Stud-Nose Cone	022822
13	Panel A.-Front	X51590
14	Pan A.-Drip-15-1/8 Long	X51601
15	Shield-Splash 23 Long	022766
16	Tray-Drip 22-7/8 L x 5-1/8 W	014533
17	Leg-4" SS w/O-Ring	013458
18	Skirt-Air Flow	048489

Model 339

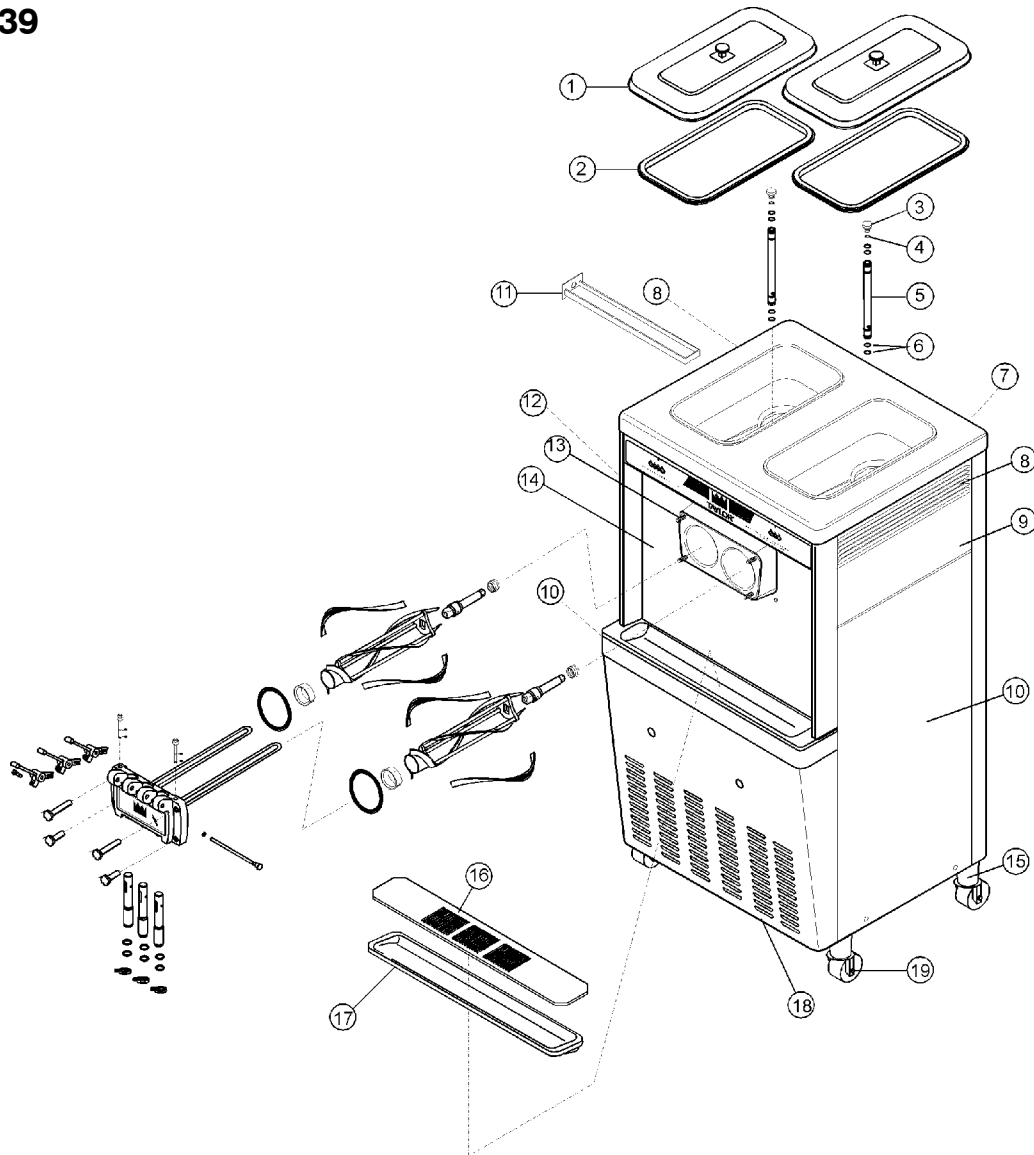

Item	Description	Part No.
1	Cover A.-Hopper-Standard	X38458
2	Gasket-Hopper Cover 20 Qt.	038474
3	Orifice	022465-100
4	O-Ring 3/8 OD x .070 W	016137
5	Tube A.-Feed SS 5/32 Hole	X29429-2
6	O-Ring .643 OD x .077 W	018572
7	Panel-Rear	017563
8	Louver-Side (Right & Left)	017471
9	Panel-Upper Side Right	028741
10	Panel A.-Lower Side (R & L)	X24424

Item	Description	Part No.
11	Pan-Drip 17-1/4" Long	027504
12	Panel-Upper Side Left	028740
13	Stud-Nose Cone	022822
14	Panel A.-Front	X32956
15	Adaptor A.-Caster	X18915
16	Shield-Splash 23 L	022766
17	Tray-Drip 22-7/8 L x 5-1/8 W	014533
18	Panel-Service	024439
19	Caster-Swivel 5/8 Stem 4" Wheel	018794

Three Spout Door

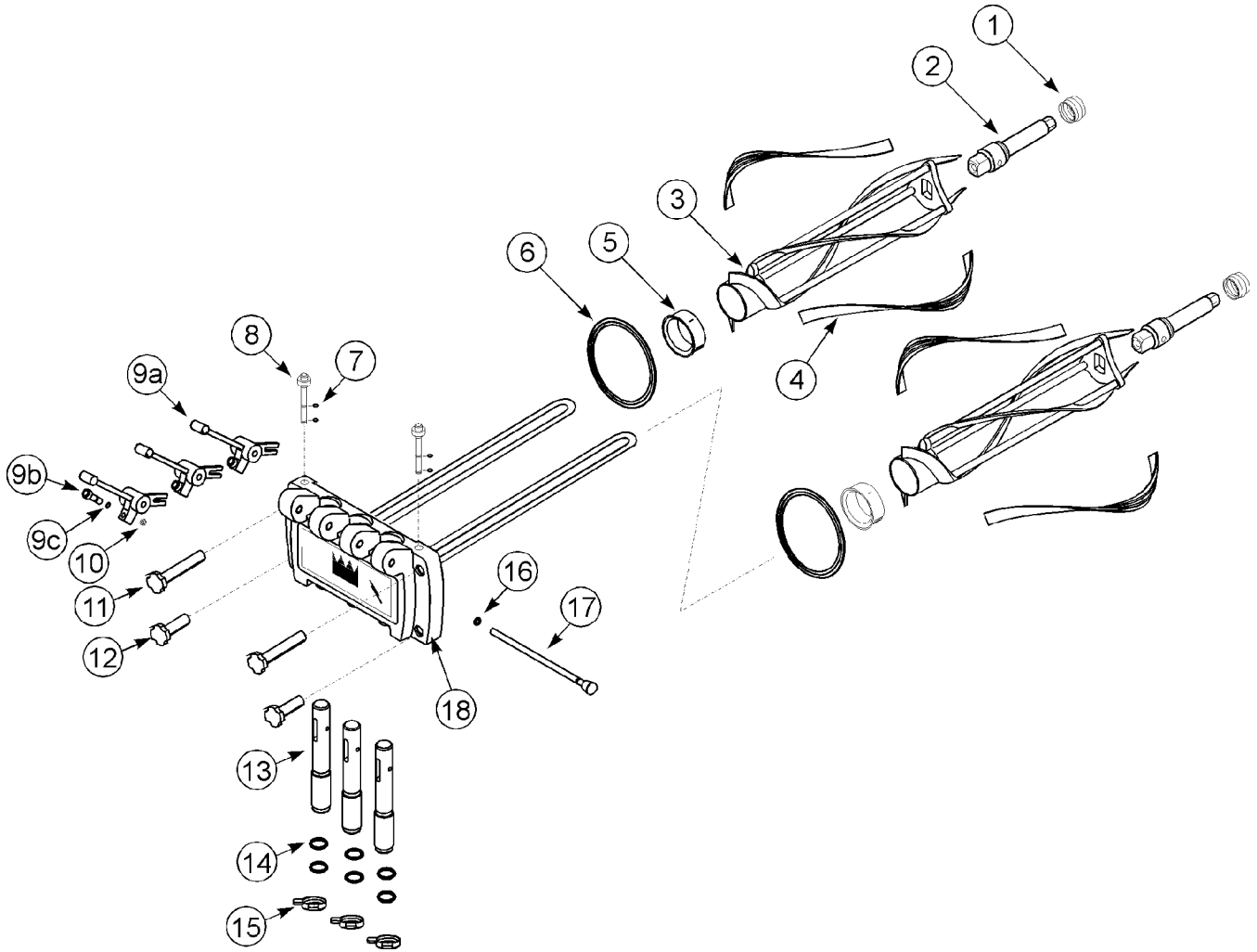

Item	Description	Part No.
1	Seal-Drive Shaft	032560
2	Shaft-Beater	033235
3	Beater A.-2.8 Qt. Helicore	X35466
4	Blade-Scraper-Plastic	035480
5	Bearing-Front	050216
6	Gasket-Door HT 4" Double	048926
7	O-Ring 3/8 OD x .070 W	016137
8	Plug-Prime	028805
9	Handle A.-Adj. Stainless Screw	X33687
9a	Handle-Adjustable	028804
9b	Screw-Adjustment-Stainless	033662

Item	Description	Part No.
9c	O-Ring 1/4 OD x .070 W	015872
10	Nut-5/16-24 18-8 SS Jam	029639-BLK
11	Nut-Stud Long	034382
12	Nut-Stud Short	034383
13	Valve A.-Draw	X18303
14	O-Ring 7/8 OD x .103 W	014402
15	Cap-Design 1.010" ID-6 Point	014218
16	O-Ring 5/16 OD x .070 W	016272
17	Rod A.-Pivot	X20683
18	Door A.-3 Spout SH BAF W/PRG	X51532-15

Accessories

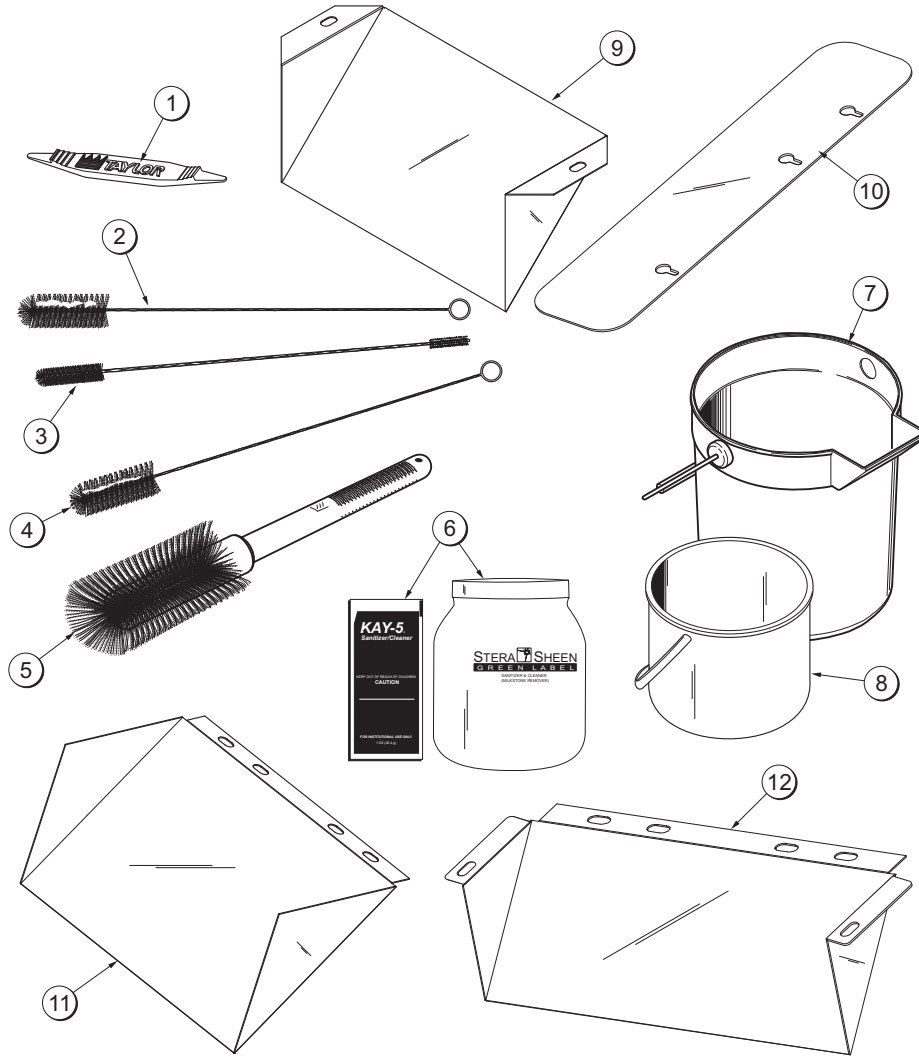

ITEM	DESCRIPTION	PART NO.
1	TOOL-O-RING REMOVAL-FREEZER	048260-WHT
2	BRUSH-REAR BRG 1IN.DX2IN.LGX	013071
3	BRUSH-DOUBLE ENDED-PUMP&FEED	013072
4	BRUSH-DRAW VALVE 1"ODX2"X17"	013073
5	BRUSH-MIX PUMP BODY-3"X7"WHITE	023316
6	SANITIZER KAY-5 125 PKTS	041082
	SANITIZER-STERA SHEEN	065293*

ITEM	DESCRIPTION	PART NO.
7	PAIL-MIX 10 QT. M336,339,751,754,774,794	013163
8	PAIL-6 QT. M338,750	023348
9	DEFLECTOR-BLOWER EXHAUST M794	047912
10	SKIRT-AIR FLOW M338	048489
11	DEFLECTOR-BLOWER EXHAUST M336	048345
12	DEFLECTOR-BLOWER EXHAUST M339,751,754,774	046586

*MODEL 336 IS SHIPPED WITH STERA SHEEN.
OTHER MODELS ARE SHIPPED WITH KAY-5.

Section 5

Important: To the Operator

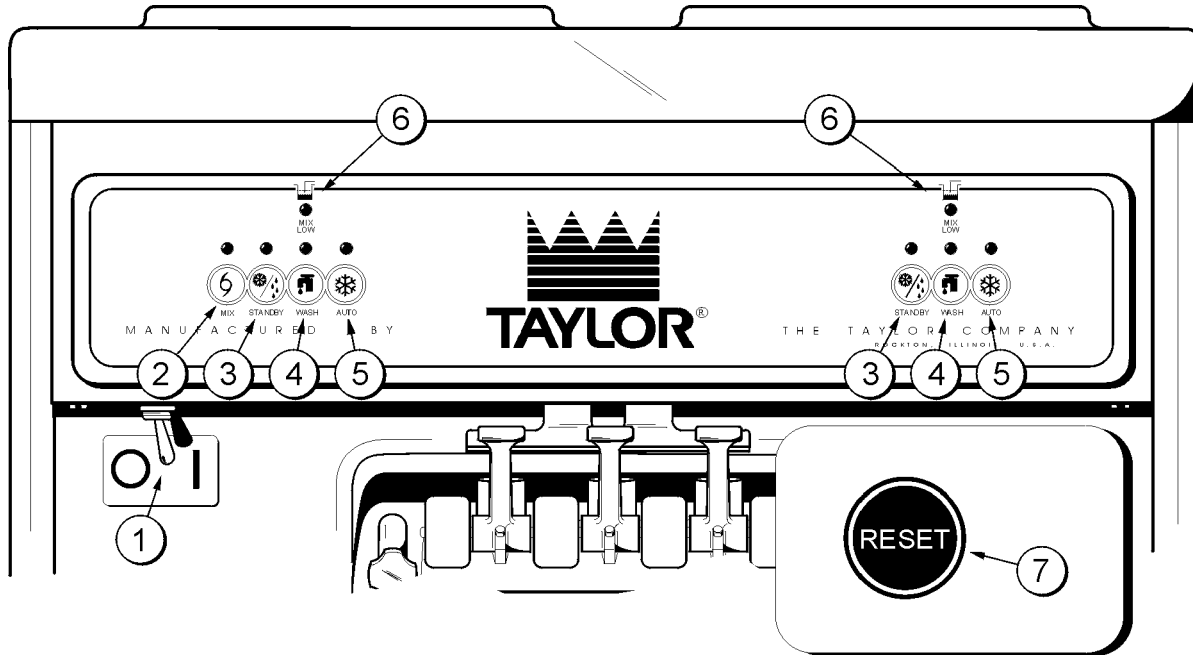

Item	Description
1	Power Switch
2	Mix Refrigeration Button
3	Standby Button
4	Wash Button
5	Auto Button
6	Indicator Light "MIX LOW"
7	Reset Button

Symbol Definitions

The following chart identifies the symbol definitions used on the operator switches.

I	= ON		= WASH
O	= OFF		= MIX LOW
6	= MIX		= STANDBY

Power Switch

When placed in the “ON” position, the power switch allows SOFTECH® control panel operation.

Indicator Light - “Mix Low”

Located on the front of the machine is a mix level indicating light. When the light is flashing, it indicates that the mix hopper has a low supply of mix and should be refilled as soon as possible. Always maintain at least 3” (76 mm) of mix in the hopper. If you neglect to add mix, a freeze-up may occur. This will cause eventual damage to the beater, blades, drive shaft, and freezer door.

Mix Refrigeration Button

When the mix refrigeration button is pressed, the light comes on indicating the mix hopper refrigeration system is operating. The mix refrigeration is controlled by the left side of the freezer as viewed from the operator end. The mix refrigeration function cannot be cancelled unless the “AUTO” or “STANDBY” modes are cancelled first.

“Standby”

The Separate Hopper Refrigeration System (SHR) and the Cylinder Temperature Retention System (CTR) are standard features. The SHR feature incorporates the use of a separate small refrigeration system to maintain the mix in the hopper below 40° (4.4°C) to assure bacteria control. The CTR feature works with the SHR to maintain a good quality product. During long “No Sale” periods, it is necessary to warm the product in the freezing cylinder to approximately 35°F to 40°F (1.7°C to 4.4°C) to prevent overbeating and product breakdown.

To activate the SHR and CTR features, press the “STANDBY” button. Remove the air orifice and place the air tube (**end without the hole**) into the mix inlet hole.

When the “STANDBY” button is pressed, the light comes on, indicating the CTR (Cylinder Temperature Retention System) feature has been activated. In the “STANDBY” mode, the “WASH” and “AUTO” functions are automatically cancelled. The mix refrigeration function is automatically locked in to maintain the mix in the hopper.

To resume normal operation, press the “AUTO” button. When the unit cycles off, the product in the freezing cylinder will be at serving viscosity. At this time, place the air tube (**end with the hole**) into the mix inlet hole and install the air orifice.

“Wash”

When the “WASH” button is pressed, the light comes on. This indicates beater motor operation. The “STANDBY” or “AUTO” modes must be cancelled first to activate the “WASH” mode.



Note: The Model 336 cannot be operated in the “WASH” mode if the opposite side of the freezer is in “AUTO”. Failure to comply with this instruction will cause the rinse or sanitizing solution to freeze.

“Auto”

When the “AUTO” button is pressed, the light comes on. This indicates that the main refrigeration system has been activated. In the “AUTO” mode, the “WASH” or “STANDBY” functions are automatically cancelled. The mix refrigeration function is automatically locked in to maintain the mix in the mix hopper.

Note: An indicating light and an audible tone will sound whenever a mode of operation has been pressed. To cancel any function, press the button again. The light and mode of operation will shut off.

Reset Button

The reset button is located in the service panel. The reset protects the beater motor from an overload condition. If an overload occurs, the reset mechanism will trip. To properly reset the freezer, press the "AUTO" button to cancel the cycle. Place the power switch to the "OFF" position. Press the reset button firmly.



Note: Do not use metal objects to press the reset button. Failure to follow this instruction may result in electrocution.

Turn the power switch to the "ON" position. Press the "WASH" button and observe the freezer's performance. Open the side access panel. Make sure the beater motor is turning the drive shaft in a clockwise direction (from the operator end) without binding.

If the beater motor is turning properly, press the "WASH" button to cancel the cycle. Press the "AUTO" button (on both sides of the unit) to resume normal operation. If the freezer shuts down again, contact a service technician

Air Tube

The air tube serves two purposes. One end of the tube has a hole and the other end does not.

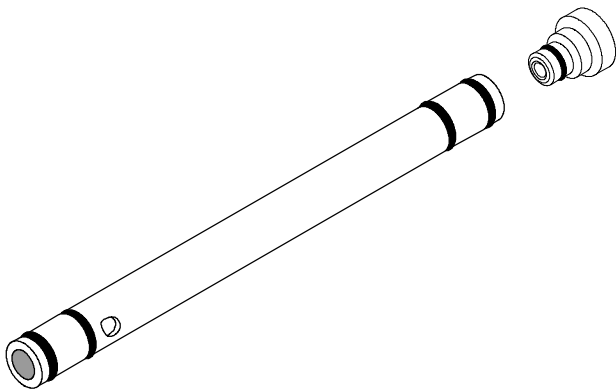

Figure 1

1. After priming the machine, lubricate the o-rings on the air tube (**the end with the hole**) and place it into the mix inlet hole. Every time the draw handle is raised, new mix and air from the hopper will flow down into the freezing cylinder. This will keep the freezing cylinder properly loaded and will maintain overrun.
2. During long "No Sale" periods, remove the air orifice. Lubricate the o-rings on the air tube (**the end without the hole**), and place it into the mix inlet hole. This will prevent any mix from entering the freezing cylinder.

The air orifice is used to meter a certain amount of air into the freezing cylinder. The air orifice maintains overrun and allows enough mix to enter the freezing cylinder after a draw.

Adjustable Draw Handle

These units feature an adjustable draw handle to provide the best portion control. The draw handle should be adjusted to provide a flow rate of 5 to 7-1/2 oz. of product per 10 seconds. To **INCREASE** the flow rate, turn the screw **COUNTERCLOCKWISE**. Turn the screw **CLOCKWISE** to **DECREASE** the flow rate. During "Sanitizing" and "Rinsing", the flow rate can be increased by removing the pivot pin and placing the restrictive bar on the **TOP**. When drawing product, **always** place the restrictive bar on the **bottom**.

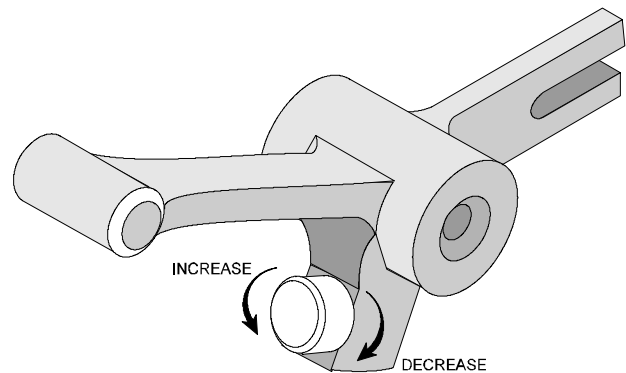

Figure 2

Section 6

Operating Procedures

Each unit stores mix in a hopper. The mix then flows by **gravity** through an air tube down into the freezing cylinder. They all have 2.8 quart (2.6 liter) capacity freezing cylinders. All models have 20 quart (18.9 liter) mix hoppers.

Duplicate the following procedures, where they apply, for the second freezing cylinder.

We begin our instructions at the point where we enter the store in the morning and find the parts disassembled and laid out to air dry from the previous night's cleaning.

These opening procedures will show you how to assemble these parts into the freezer, sanitize them, and prime the freezer with fresh mix in preparation to serve your first portion.

If you are disassembling the machine for the first time or need information to get to this starting point in our instructions, turn to page 20, "Disassembly", and start there.

Assembly

Note: When lubricating parts, use an approved food grade lubricant (example: Taylor Lube).



MAKE SURE THE CONTROL SWITCH IS IN THE "OFF" POSITION.

Step 1

Install the drive shaft. Lubricate the groove and shaft portion that comes in contact with the bearing on the beater drive shaft. Slide the seal over the shaft and groove until it snaps into place.



DO NOT lubricate the hex end of the drive shaft. Fill the inside portion of the seal with 1/4" more lubricant and lubricate the flat side of the seal that fits onto the rear shell bearing.

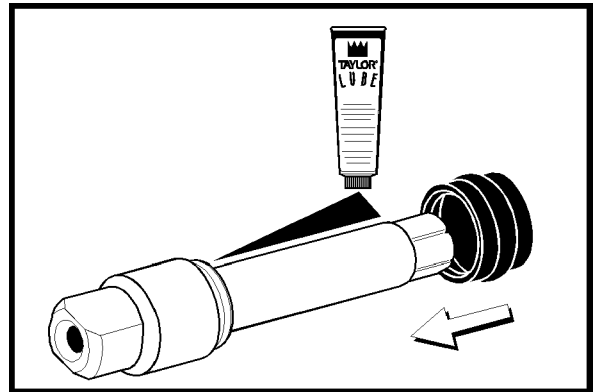

Figure 3

Insert the drive shaft into the freezing cylinder, hex end first, and into the rear shell bearing until the seal fits securely over the rear shell bearing. Engage the hex end firmly into the drive coupling. Be sure the drive shaft fits into the drive coupling without binding.

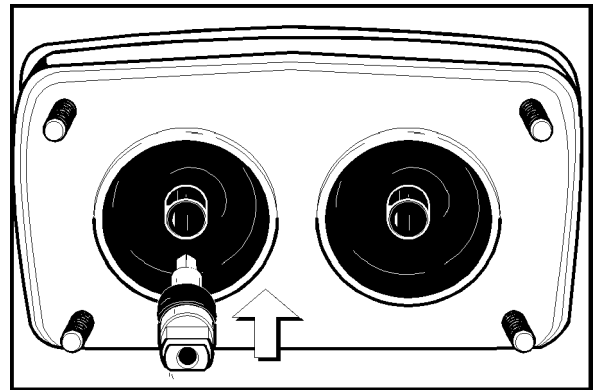

Figure 4

Step 2

Take one of the scraper blades and slip it under the hook at the front of the beater. Wrap the blade around the beater following the helix and pushing the blade down onto the helix as you wrap. At the back end of the beater, slip the blade under the hook. **Repeat this step** for the second scraper blade.

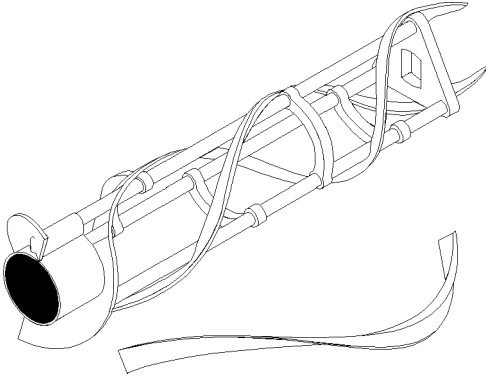

Figure 5

Holding the beater securely, slide the beater one third of the way into the freezing cylinder. Looking into the freezing cylinder, align the hole at the rear of the beater with the flats on the end of the drive shaft.

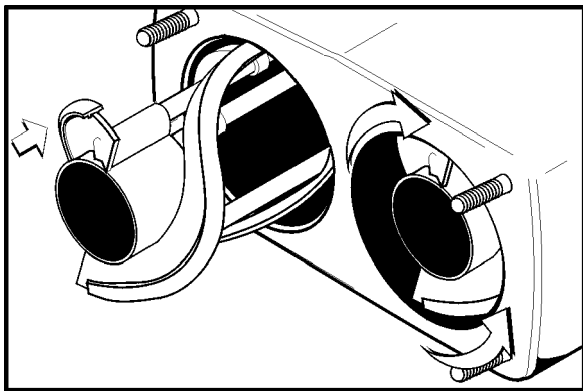

Figure 6

Slide the beater the remainder of the way into the freezing cylinder and over the end of the drive shaft. The beater should fit snugly, but not so tightly that the beater cannot be turned slightly to engage the drive shaft. If the beater slides in too easily with little or no resistance, there will not be enough force against the beater to hold the blades in place. If this is the case, contact your authorized Taylor service agent.

Repeat Steps 1 and 2 for the other side of the freezer.

Step 3

Assemble the freezer door. Place the large rubber gaskets into the grooves on the back side of the freezer door.

Slide the white plastic front bearings over the baffle rods onto the bearing hubs making certain that the flanged end of the bearing is resting against the freezer door.



DO NOT LUBRICATE THE GASKETS OR THE FRONT BEARINGS. Damage to components may occur.

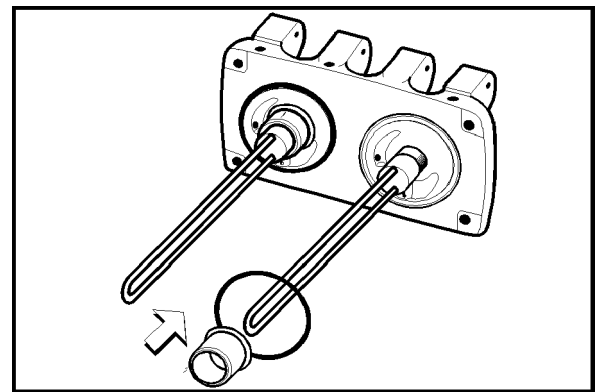

Figure 7

Slide the two o-rings into the grooves on the prime plugs. Apply an even coat of Taylor Lube to the o-rings and shafts.

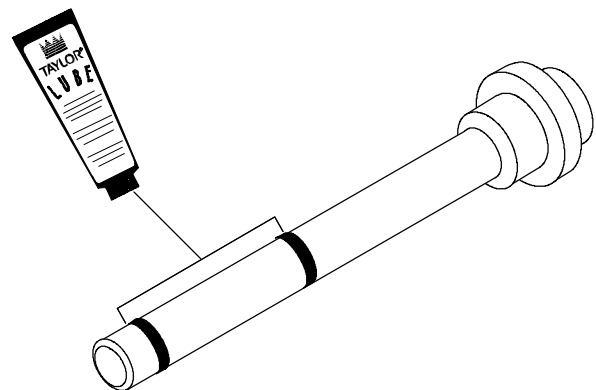

Figure 8

Insert the prime plugs into the holes in the top of the freezer door, and push down.

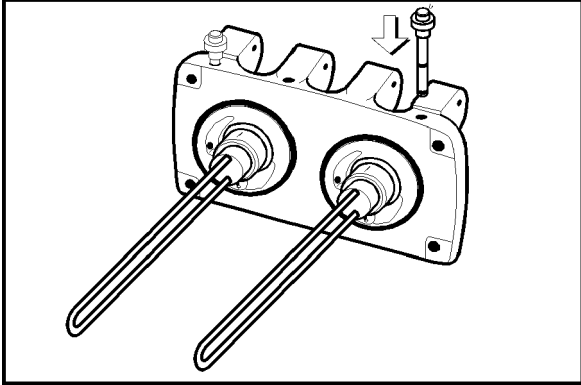

Figure 9

Step 4

Install the freezer door. Insert the baffle rods through the opening in the beaters and seat the door flush with the freezing cylinder. With the door seated on the freezer studs, install the handscrews. Tighten equally in a crisscross pattern to insure the door is snug.



Note: The short handscrews go on the bottom and the long handscrews go on top.

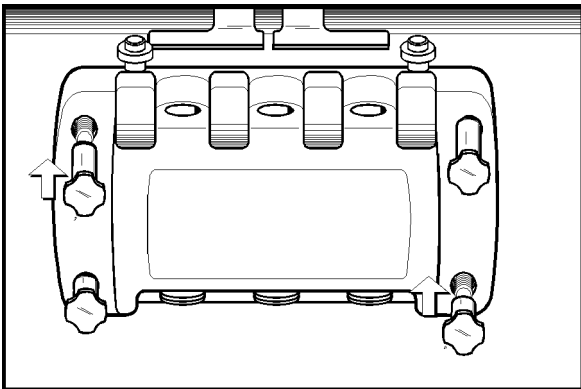

Figure 10

Step 5

Install the three draw valves. Slide the two o-rings into the grooves on the draw valves, and lubricate.

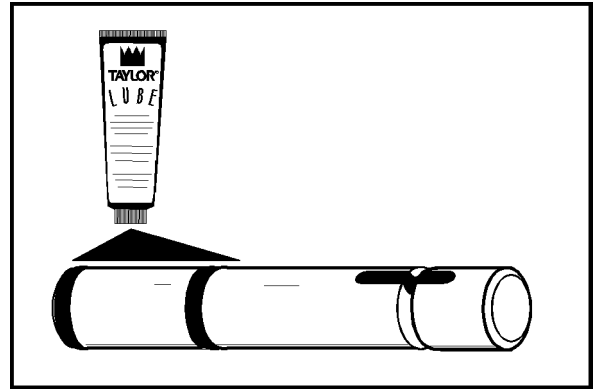

Figure 11

Lubricate the inside of the freezer door spouts, top and bottom, and insert the draw valves from the **bottom** until the slot in the draw valves comes into view.

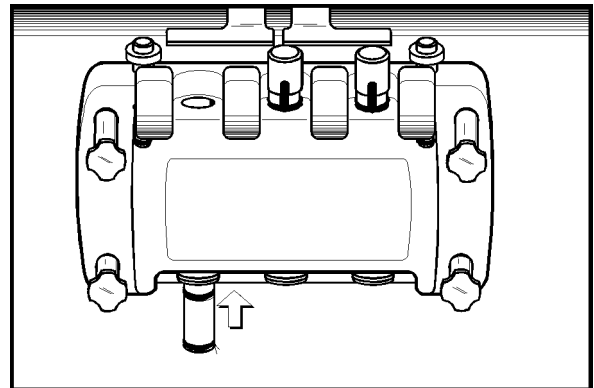

Figure 12

Step 6

Install the adjustable draw handles. Slide the o-ring into the groove on the pivot pin, and lubricate.

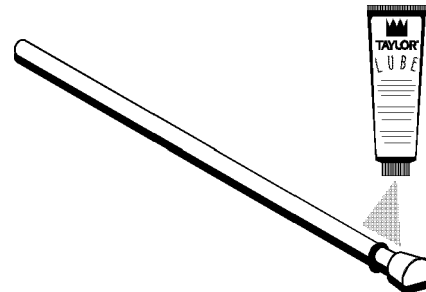

Figure 13

Slide the fork over the bar in the slot of the draw valve. Secure with pivot pin.

Note: The Models 336, 338 and 339 have three draw handles. Slide the fork of the draw handle in the slot of the draw valve, starting from the right. Slide the pivot pin through each draw handle as you insert them into the draw valves.

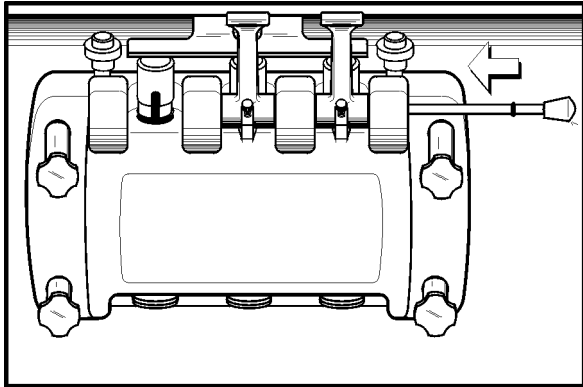

Figure 14

Note: These units feature adjustable draw handles to provide the best portion control. The draw handles can be adjusted for different flow rates. See page 11 for more information on adjusting these handles.

Step 7

Snap the design caps over the end of the door spouts.

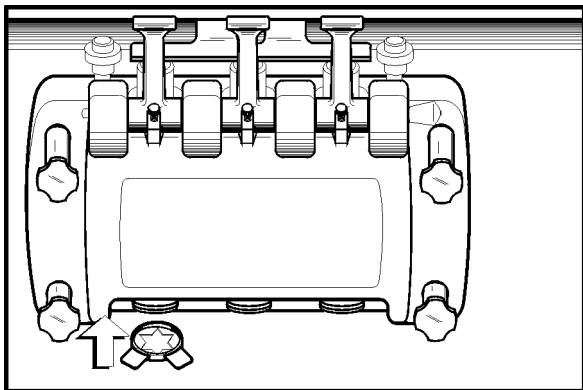

Figure 15

Step 8

Install the front drip tray and the splash shield under the door spouts.

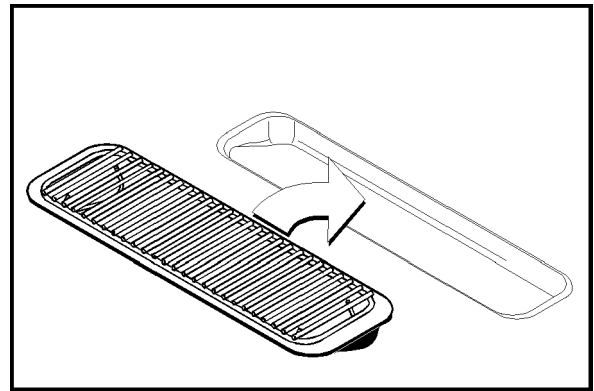

Figure 16

Step 9

Slide the rear drip pan into the hole in the side panel (front panel on a Model 338).

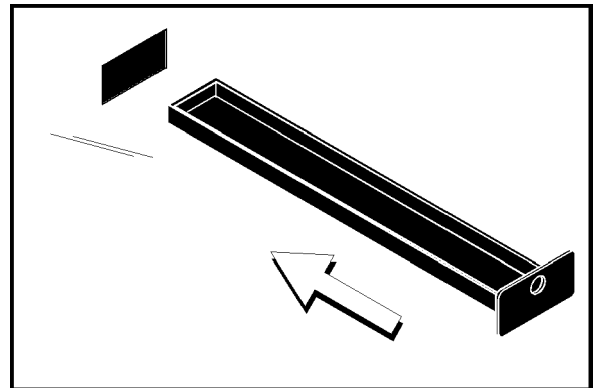

Figure 17

Step 10

Slide two o-rings on one end of the air tube. Slide two o-rings on the other end of the air tube.

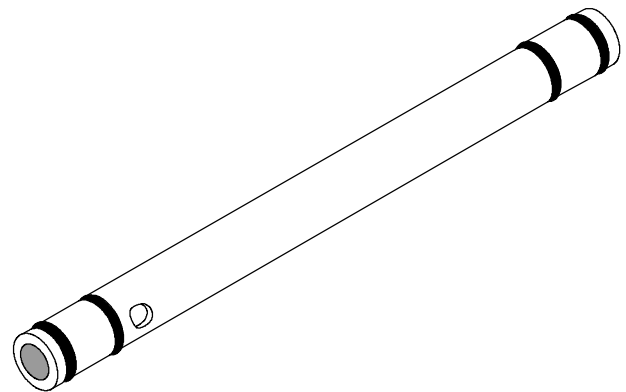

Figure 18

Slide the small o-ring into the groove of the air orifice. Do not lubricate the o-ring.

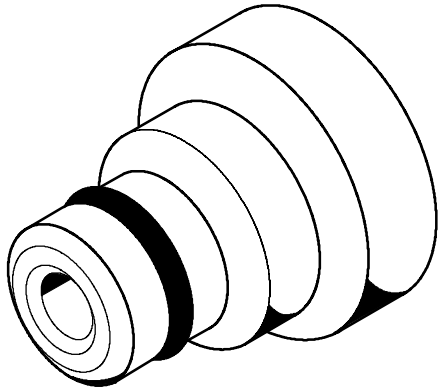

Figure 19

Note: Make sure the hole in the air orifice is clean and is not clogged. If the hole in the air orifice should become clogged, use soap and hot water to clear the hole.



Do not enlarge the hole in the air orifice.

Install the air orifice into the hole in the top of the air tube (in the end without the small hole on the side).

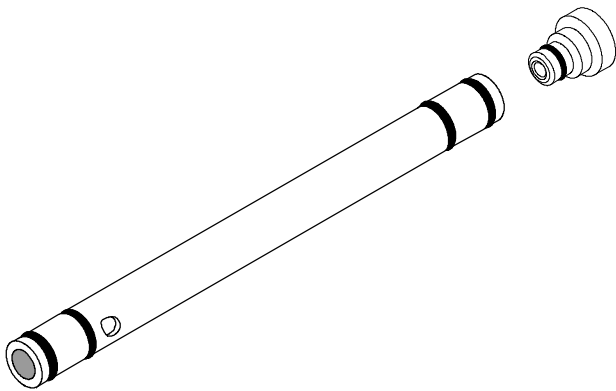

Figure 20

Step 11

Lay the air tube (with the air orifice installed) and the hopper gasket in the bottom of the mix hopper for sanitizing.

Repeat Steps 10 and 11 for the other side of the freezer.

Sanitizing

Step 1

Prepare two gallons (7.6 liters) of an approved 100 PPM sanitizing solution (example: Kay-5®). USE WARM WATER AND FOLLOW THE MANUFACTURER'S SPECIFICATIONS.

Step 2

Pour the two gallons (7.6 liters) of sanitizing solution into the hopper and allow it to flow into the freezing cylinder.

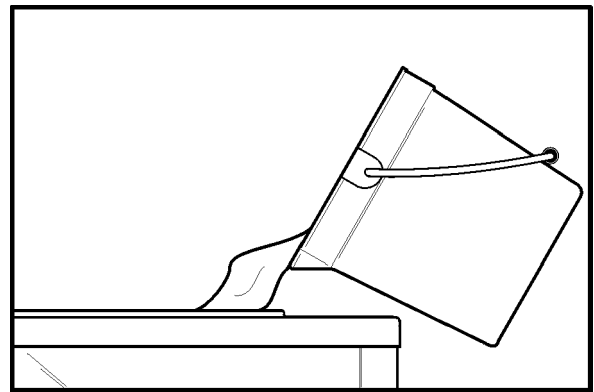

Figure 21

Step 3

While the solution is flowing into the freezing cylinder, brush clean the mix hopper. When cleaning the hopper, take particular care in brushing the mix level sensing probe on the rear wall of the hopper, the mix inlet hole, the air tube, and the hopper gasket.

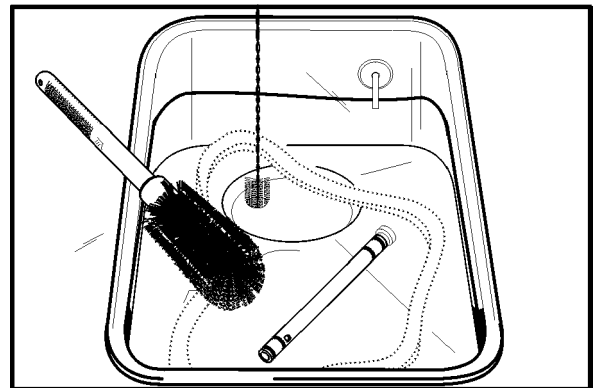

Figure 22

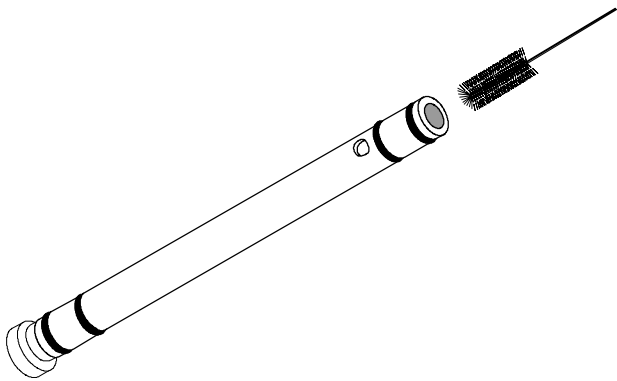

Figure 23

Step 4
Place the power switch in the “ON” position.

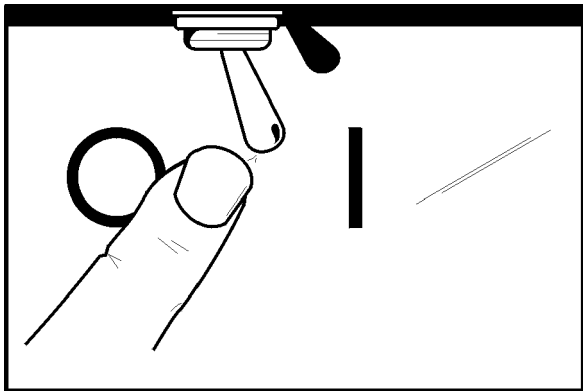

Figure 24

Step 5
Press the “WASH” button. This will cause the sanitizing solution in the freezing cylinder to agitate. Allow it to agitate for five minutes.

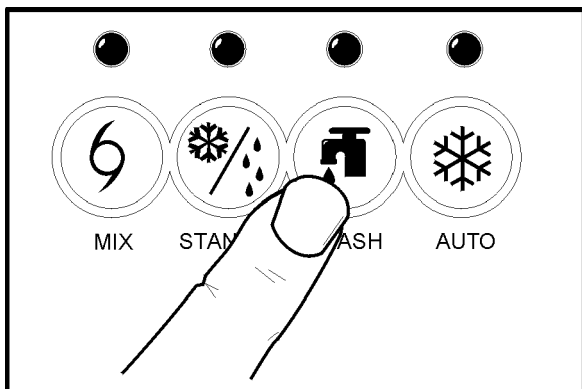

Figure 25

Step 6

Place an empty pail beneath the door spout and raise the prime plug.

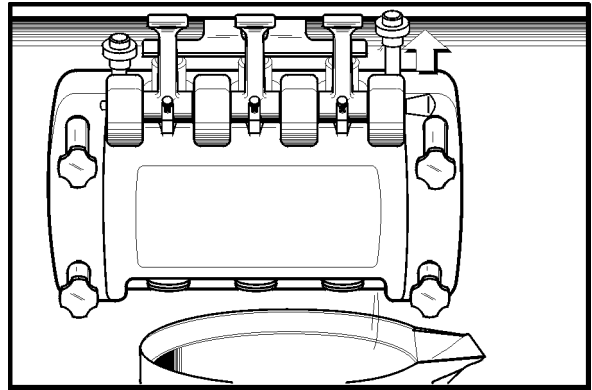

Figure 26

Step 7

When a **steady** stream of sanitizing solution is flowing from the prime plug opening in the bottom of the freezer door, lower the draw handle. Draw off all the sanitizing solution.

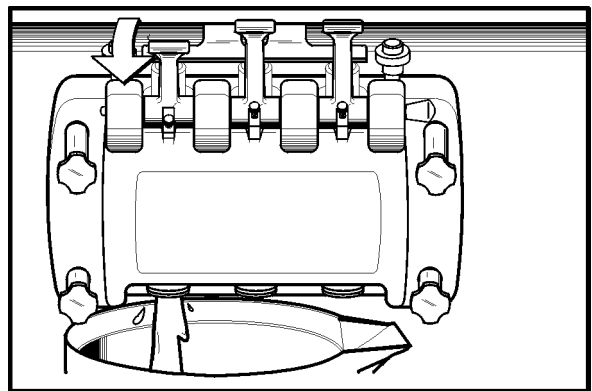

Figure 27

Note: Momentarily pull the center draw handle down to sanitize the center door spout.

Step 8

Once the sanitizer stops flowing from the door spout, raise the draw handle and press the “WASH” button, cancelling the beater motor operation.



Note: You have just sanitized the freezer. **Be sure your hands are sanitized** before continuing these instructions.

Step 9

Assemble the hopper gasket around the top edge of the mix hopper. Stand the air tube in the corner of the hopper.

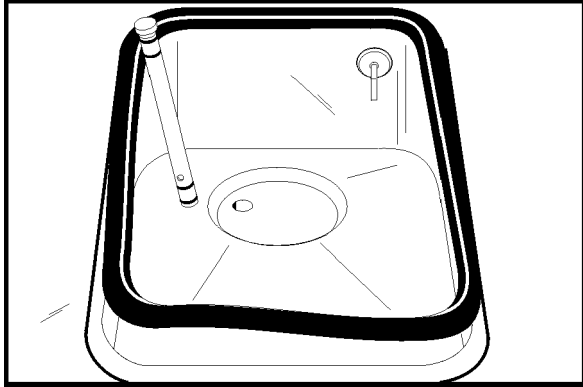

Figure 28

Repeat Steps 1 through 9 for the other side of the freezer.

Priming

Step 1

With a pail beneath the door spout, lower the draw handle. Be sure the prime plug is still in the UP position. Pour two gallons (7.6 liters) of fresh mix into the mix hopper and allow it to flow into the freezing cylinder. This will force out any remaining sanitizing solution. When full strength mix is flowing from the door spout, raise the draw handle.

Note: Use only **fresh** mix when priming the freezing cylinder.

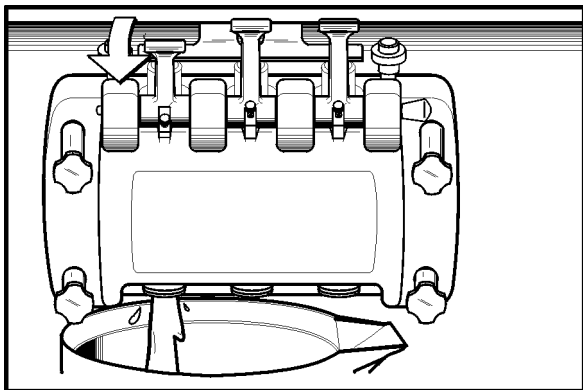

Figure 29

Step 2

Once a **steady** stream of mix starts to flow from the prime plug opening in the bottom of the freezer door, push down the prime plug.

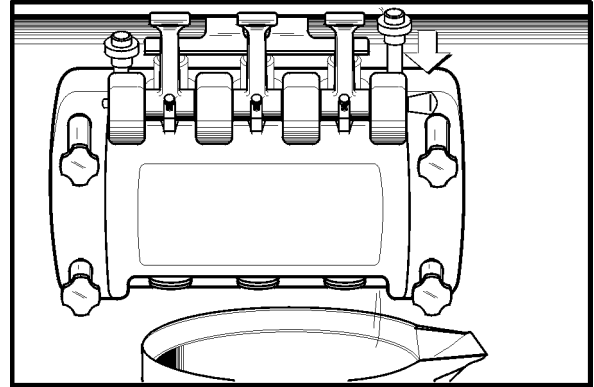

Figure 30

Step 3

Lubricate the o-rings on the air tube on the end with the small hole on the side.

Step 4

Install the air tube in the "AUTO" position.

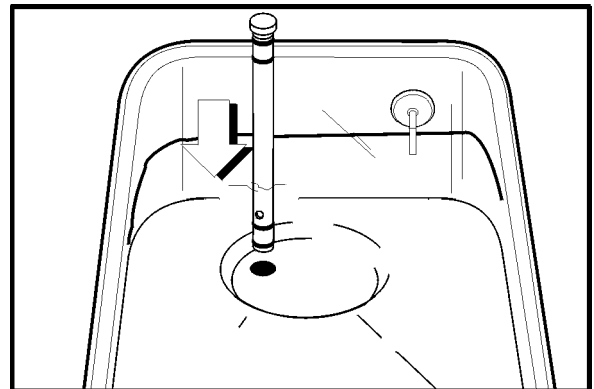

Figure 31

Step 5

Press the "AUTO" button. The "AUTO" light will come on indicating the main refrigeration system is operating. When the unit cycles off, the product will be at serving viscosity.

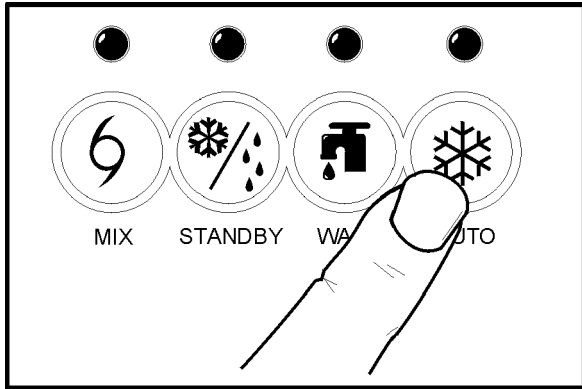

Figure 32

Note: The mix refrigeration light will come on, indicating the mix refrigeration system is operating to maintain the mix in the mix hopper.

Step 6

Fill the hopper with mix. As the mix level comes in contact with the mix level sensing probe on the rear wall of the hopper, the "MIX LOW" light will shut off.

Step 7

Place the mix hopper cover in position over the mix hopper.

Repeat Steps 1 through 7 for the other side of the freezer.

Closing Procedure

To disassemble your unit, the following items will be needed:

- Two cleaning pails
- Sanitized stainless steel rerun can with lid
- Necessary brushes (provided with freezer)
- Cleaner
- Single service towels

Draining Product From the Freezing Cylinder

Step 1

Press the "AUTO" button, cancelling compressor and beater motor operation.

Press the mix refrigeration button, cancelling the mix hopper refrigeration system.

Step 2

Remove the hopper cover, hopper gasket and air tube. Take these parts to the sink for cleaning.

Step 3

With a sanitized pail beneath the door spout, press the "WASH" button. Lower the draw handle and drain the remaining product from the freezing cylinder and the mix hopper.

Step 4

When the flow of product stops, press the "WASH" button, and raise the draw handle. If local health codes permit, empty the rerun into a sanitized stainless steel can. Cover the container and place it in the walk-in cooler.

Repeat Steps 1 through 4 for the other side of the freezer.

Note: For the Model 336, both sides must be in WASH. If one side is in AUTO and the other is in WASH, the side that is in WASH will continue to freeze.



ALWAYS FOLLOW LOCAL HEALTH CODES.

Rinsing

Step 1

Pour two gallons (7.6 liters) of **cool** clean water into the mix hopper. With the brushes provided, scrub the mix hopper, mix inlet hole and mix level sensing probe.

Step 2

With a pail beneath the door spout, raise the prime plug and press the "WASH" button.

Step 3

When a steady stream of rinse water is flowing from the prime plug opening in the bottom of the freezer door, lower the draw handle. Drain all the rinse water from the freezing cylinder, raise the draw handle and press the "WASH" button, cancelling the "WASH" mode.

Repeat Steps 1 through 3 for the other side of the freezer.

Cleaning

Step 1

Prepare two gallons (7.6 liters) of an approved cleaning solution (example: Kay-5®). USE WARM WATER AND FOLLOW THE MANUFACTURER'S SPECIFICATIONS.

Step 2

Push down the prime plug. Pour the two gallons (7.6 liters) of cleaning solution into the mix hopper.

Step 3

While the solution is flowing into the freezing cylinder, brush clean the mix hopper, mix level sensing probe, and the mix inlet hole.

Step 4

Press the "WASH" button. This will cause the cleaning solution in the freezing cylinder to agitate.

Step 5

Place an empty pail beneath the door spout and raise the prime plug.

Step 6

When a steady stream of cleaning solution is flowing from the prime plug opening in the bottom of the freezer door, lower the draw handle. Draw off all of the solution.

Step 7

Once the cleaner stops flowing from the door spout, raise the draw handle and press the "WASH" button, cancelling the "WASH" mode.

Repeat Steps 1 through 7 for the other side of the freezer.

Disassembly

Step 1



BE SURE THE POWER SWITCH IS IN THE "OFF" POSITION. MAKE SURE NO LIGHTS ARE LIT ON THE CONTROL PANEL.

Step 2

Remove the handscrews, freezer door, beaters, scraper blades, and drive shafts from the freezing cylinders. Take these parts to the sink for cleaning.

Step 3

Remove the front drip tray and the splash shield.

Brush Cleaning

Step 1

Prepare a sink with an approved cleaning solution (example: Kay-5®). USE WARM WATER AND FOLLOW THE MANUFACTURER'S SPECIFICATIONS. If another approved cleaner is used, dilute it according to the label instructions. (**IMPORTANT:** Follow the label directions. Too STRONG of a solution can cause parts damage, while too MILD of a solution will not provide adequate cleaning.) Make sure all brushes provided with the freezer are available for brush cleaning.

Step 2

Remove the seals from the drive shafts.

Step 3

From the freezer door remove:

- gaskets
- front bearings
- pivot pins
- adjustable draw handles
- design caps
- draw valves
- prime plugs

Remove all o-rings.

Note: To remove o-rings, use a single service towel to grasp the o-ring. Apply pressure in an upward direction until the o-ring pops out of its groove. With the other hand, push the top of the o-ring forward and it will roll out of the groove and can be easily removed. If there is more than one o-ring to be removed, always remove the rear o-ring first. This will allow the o-ring to slide over the forward rings without falling into the open grooves.

Step 4

Remove the o-rings from the air tubes and air orifices.

Step 5

Return to the freezer with a small amount of cleaning solution. Brush clean the rear shell bearings at the back of the freezing cylinders with the black bristle brush.

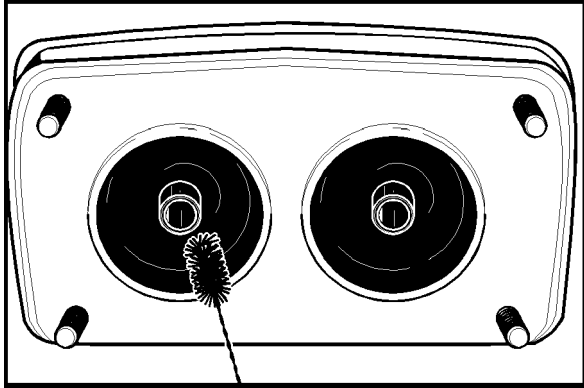

Figure 33

Step 6

Remove the rear drip pan and take it to the sink for cleaning.

Note: If the drip pan is filled with an excessive amount of mix, refer to the Troubleshooting Guide.

Step 7

Thoroughly brush clean all disassembled parts in the cleaning solution making sure all lubricant and mix film is removed. Take particular care to brush clean the draw valve cores in the freezer door. Place all the cleaned parts on a clean, dry surface to air dry overnight.

Step 8

Wipe clean all exterior surfaces of the freezer.

Section 7 Important: Operator Checklist

During Cleaning and Sanitizing

Cleaning and sanitizing schedules are governed by your State or local regulatory agencies and must be followed accordingly. The following check points should be stressed during the cleaning and sanitizing operations.

WE RECOMMEND DAILY CLEANING AND SANITIZING.



ALWAYS FOLLOW LOCAL HEALTH CODES.

Troubleshooting Bacterial Count

- 1. Thoroughly clean and sanitize machine regularly, including complete disassembly and brush cleaning.
 - 2. Use all brushes supplied for thorough cleaning. The brushes are specially designed to reach all mix passageways.
 - 3. Use the white bristle brush to clean the mix inlet hole which extends from the mix hopper down to the rear of the freezing cylinder.
 - 4. Use the black bristle brush to thoroughly clean the rear shell bearing located at the rear of the freezing cylinder. Be sure to have a generous amount of cleaning solution on the brush.
 - 5. IF LOCAL HEALTH CODES PERMIT THE USE OF RERUN, make sure the mix rerun is stored in a sanitized, covered stainless steel container and used the following day. **DO NOT prime the machine with rerun.** When using rerun, skim off the foam and discard. Mix the rerun with fresh mix in a ratio of 50/50 during the days operation.
- 6. On a designated day of the week, run the mix as low as feasible and discard it after closing. This will break the rerun cycle and reduce the possibility of high bacteria and coliform counts.
 - 7. Properly prepare the cleaning and sanitizing solutions. Read and follow label directions carefully. Too strong of a solution may damage the parts and too weak of a solution will not do an adequate job of cleaning or sanitizing.
 - 8. The temperature of the mix in the mix hopper and walk-in cooler should be below 40°F. (4.4°C.).

Regular Maintenance Checks

- 1. Replace scraper blades that are nicked or damaged. Before installing the beater assembly, be certain that scraper blades are properly attached to the helix.
- 2. Check the rear shell bearing for signs of wear (excessive mix leakage in rear drip pan) and be certain it is properly cleaned.
- 3. Using a screwdriver and cloth towel, keep the rear shell bearing and the female hex drive socket clean and free of lubricant and mix deposits.
- 4. Dispose of o-rings and seals if they are worn, torn, or fit too loosely, and replace with new ones.
- 5. Follow all lubricating procedures as outlined in "Assembly".
- 6. If your machine is air cooled, check the condensers for accumulation of dirt and lint. Dirty condensers will reduce the efficiency and capacity of the machine. Condensers should be cleaned **monthly** with a soft brush. **Never** use screwdrivers or other metal probes to clean between the fins.
Note: For machines equipped with an air filter, it will be necessary to vacuum clean the filters on a monthly schedule.



Caution: Always disconnect electrical power prior to cleaning the condenser.

- 7. If your machine is equipped with an auxiliary refrigeration system, check the auxiliary condenser for accumulation of dirt and lint. Dirty condensers will reduce the refrigeration capacity of the mix hopper. Condensers must be cleaned **monthly** with a soft brush. **Never** use screwdrivers or other metal probes to clean between the fins.



Caution: Always disconnect electrical power prior to cleaning the condenser.

- 8. If your machine is water cooled, check the water lines for kinks or leaks. Kinks can occur when the machine is moved back and forth for cleaning or maintenance purposes. Deteriorated or cracked water lines should be replaced only by an authorized Taylor distributor.

Winter Storage

If the place of business is to be closed during the winter months, it is important to protect the freezer by following certain precautions, particularly if the building is subject to freezing conditions.

Disconnect the freezer from the main power source to prevent possible electrical damage.

On water cooled freezers, disconnect the water supply. Relieve pressure on the spring in the water valve. Use air pressure on the outlet side to blow out any water remaining in the condenser, and then add a liberal amount of permanent type auto anti-freeze. **This is extremely important.** Failure to follow this procedure may cause severe and costly damage to the refrigeration system.

Your local Taylor Distributor can perform this winter storage service for you.

Wrap detachable parts of the freezer such as beater, blades, drive shaft, and freezer door, and place them in a protected dry place. Rubber trim parts and gaskets can be protected by wrapping them with moisture-proof paper. All parts should be thoroughly cleaned of dried mix or lubrication which attract mice and other vermin.

Section 8

Troubleshooting Guide

PROBLEM	PROBABLE CAUSE	REMEDY	PAGE REF.
1. No product is being dispensed with draw valve open and the machine in the "AUTO" mode.	a. Freeze-up in mix inlet hole.	a. Call service technician to adjust the mix hopper temperature.	---
	b. Beater motor out on reset.	b. Reset the freezer.	11
	c. The beater is rotating counterclockwise from the operator end.	c. Contact service technician to correct rotation to clockwise from operator end.	---
	d. The circuit breaker is off or the fuse is blown.	d. Turn the breaker on, or replace the fuse.	---
	e. There is inadequate mix in the mix hopper.	e. Fill the mix hopper with mix.	19
	f. The air orifice is not installed.	f. Install air orifice in air tube.	18
	g. Air tube is installed in the "STANDBY" position.	g. Install the air tube in the "AUTO" position.	18
2. The product is too stiff.	a. The viscosity needs adjustment.	a. Contact service technician.	---
	b. The air orifice is not installed.	b. Install air orifice in air tube.	18
3. The product is too soft.	a. Viscosity needs adjustment.	a. Contact service technician.	---
	b. Not enough air space around unit. (Air cooled units)	b. Allow for adequate air flow across the condenser.	1
	c. Worn scraper blades.	c. Replace regularly.	27
	d. Dirty condenser (A/C)	d. Clean monthly.	22
	e. Mix is out of date.	e. Use only fresh mix.	---
	f. Loss of water. (W/C)	f. Locate cause of water loss and correct.	23
	g. Loss of refrigerant.	g. Call a service technician.	---
4. The mix in the mix hopper is too cold.	a. The temperature is out of adjustment.	a. Call service technician to adjust the mix hopper temperature.	---

PROBLEM	PROBABLE CAUSE	REMEDY	PAGE REF.
5. The mix in the mix hopper is too warm.	a. The temperature is out of adjustment.	a. Call service technician to adjust the mix hopper temperature.	---
	b. Missing or defective mix hopper gasket.	b. Replace/install the gasket around the mix hopper.	18
	c. The mix hopper cover is not in position.	c. Place the cover in position.	19
	d. The mix refrigeration light is not lit.	d. Press mix refrigeration button.	19
	e. The condenser is dirty.	e. Clean the condenser.	22
6. The drive shaft is stuck in the drive coupling.	a. Rounded corners of drive shaft, coupling, or both.	a. Call service technician to correct cause, and to replace the necessary components. Do not lubricate the hex end of the drive shaft.	---
	b. Mix and lubricant collected in the drive coupling.	b. Brush clean the rear shell bearing area regularly.	21
7. The freezing cylinder walls are scored.	a. The beater assembly is bent.	a. Call service technician to repair or replace the beater and to correct the cause of insufficient mix in the freezing cylinder.	---
	b. The front bearing is missing or worn on the freezer door.	b. Install or replace the front bearing.	13
8. Excessive mix leakage into the rear drip pan.	a. Missing or worn drive shaft seal on drive shaft.	a. Install or replace regularly.	12 / 27
	b. The rear shell bearing is worn.	b. Call service technician to replace rear shell bearing.	---
9. Excessive mix leakage from door spout.	a. Missing or worn draw valve o-rings.	a. Install or replace regularly.	14 / 27
	b. Inadequate lubrication of draw valve o-rings.	b. Lubricate properly.	14
	c. Wrong type of lubricant is being used (example: petroleum base lubricant).	c. Use the proper lubricant (example: Taylor Lube).	12

PROBLEM	PROBABLE CAUSE	REMEDY	PAGE REF.
10. No freezer operation after pressing the "AUTO" button.	a. Unit is unplugged.	a. Plug into wall receptacle.	---
	b. The circuit breaker is off or the fuse is blown.	b. Turn the breaker on, or replace the fuse.	---
	c. The beater motor is out on reset.	c. Reset the freezer.	11
	d. The unit has gone off on high pressure cut-out.	d. Allow the unit to cool and reset. Check for dirty condenser (air cooled) or loss of water (water cooled).	22/ 23
11. Product is not feeding into the freezing cylinder.	a. Inadequate level of mix in the mix hopper.	a. Fill the mix hopper with mix.	19
	b. The mix inlet hole is frozen up.	b. The mix hopper temperature needs adjustment. Call service technician.	---
	c. The air tube is installed incorrectly.	c. Install the air tube in the mix inlet hole, using the end with the small hole in the side.	18
	d. The air orifice is not installed.	d. Install the air orifice in the air tube.	18

Section 9

Parts Replacement Schedule

PART DESCRIPTION	EVERY 3 MONTHS	EVERY 6 MONTHS	ANNUALLY
Drive Shaft Seal	X		
Scraper Blade	X		
Freezer Door Gasket	X		
Front Bearing	X		
Draw Valve O-Ring	X		
Pivot Pin O-Ring	X		
Prime Plug O-Ring	X		
Air Tube O-Ring	X		
Air Orifice O-Ring	X		
White Bristle Brush, 3" x 7"		Inspect & Replace if Necessary	Minimum
White Bristle Brush, 1" x 2"		Inspect & Replace if Necessary	Minimum
Black Bristle Brush, 1" x 2"		Inspect & Replace if Necessary	Minimum
Double-Ended Brush		Inspect & Replace if Necessary	Minimum

Section 10

Parts List

DESCRIPTION	PART NUMBER	336 QTY.	338 QTY.	339 QTY.	WARR. CLASS	REMARKS	PARTS UPDATE
ACCUMULATOR-COPPER 2"DIA 10"	047062		1		103		
ADAPTOR A.-CASTER	X18915	4		4	103		
BEARING-FRONT	050216	2	2	2	000		
BEARING-REAR SHELL *NICK.PLATE	031324	2	2	2	000		
+GUIDE-DRIP SEAL	028992	2	2	2	000		
+NUT-BRASS BEARING	028991	2	2	2	000		
+WASHER-BEARING LOCK	012864	2	2	2	000		
BEATER A.-2.8QT-HELICORE	X35466	2	2	2	103		
+BLADE-SCRAPER-PLASTIC 13-1/4L	035480	4	4	4	000		
BELT-AX33	024396			4	000		
BELT-AX35	022848		4		000		
BELT-AX38	023873	4			000		
BLOCK-TERMINAL 2P	039422	1	1	2	103		
BLOCK-TERMINAL 5 POLE	024329	1			103		
BLOWER A.	X46573-	1			103		
BOOT-CAPACITOR INSULATING	031314	1			000		
CAPACITOR-RUN- 10 UF/370V	033047	1			103		
HOUSING A.-WWHEEL	X30160	1			103		
MOTOR-BLOWER-208/230V 50/60 HZ	046536-	1			103		
BLOWER A.	X47833-			1	103		
BOOT-CAPACITOR INSULATING	031314			1	000		
CAPACITOR-RUN- 10 UF/370V	033047			1	103		
HOUSING A.-WWHEEL	X30160			1	103		
MOTOR-BLOWER-208/230V 50/60 HZ	046536-			1	103		
BLOWER A.	X47833-			1	103		
BOOT-CAPACITOR INSULATING	031314			1	000		
CAPACITOR-RUN- 10 UF/370V	033047			1	103		
HOUSING A.-WWHEEL	X30160			1	103		
MOTOR-BLOWER-208/230V 50/60 HZ	046536-			1	103		
SCREEN-BLOWER *X30153*	030158			1	103		
CLIP	030159			4	103		
BOARD-LOGIC-GEN 2.6 W/SEL DIFF	X36641SER1	2	2	2	212		
BOARD-POWER-GEN 1 & 2	X32326-SER	2	2	2	212		
BRUSH-DOUBLE ENDED-PUMP & FEED TUBE	013072	1	1	1	000		
BRUSH-DRAW VALVE 1"ODX2"X17"L	013073	1	1	1	000		
BRUSH-MIX PUMP BODY-3"X7"WHITE	023316	1	1	1	000		
BRUSH-REAR BRG 1IN.DX2IN.LGX14	013071	1	1	1	000		
CABLE A.-2 COND-24 IN-PUSH ON	X34464		1	1	103		
CABLE-RIBBON-14C-30"L-DIP/DIL	035683		1	1	103		

+ Available Separately

DESCRIPTION	PART NUMBER	336 QTY.	338 QTY.	339 QTY.	WARR. CLASS	REMARKS	PARTS UPDATE
CABLE-RIBBON-14C-40"L-DIP/DIL	042931		1		103		
CABLE-RIBBON-PWR/RELAY-60 IN	032445	2		2	103		
CAP-DESIGN-1.010"ID-6 POINT	014218	3	3	3	000		
CASTER-SWV 5/8 STEM 4IN WHEEL	018794	4		4	103		
COMPRESSOR L63A113BBCA	048259-	1			512	MAIN	
+CAPACITOR-RUN- 20UF/440V	012906	1			103	208-230/60/1	
+CAPACITOR-START-161-193UF/250V	031790	1			103	208-230/60/1	
+RELAY-START-COMPRESSOR	038145	1			103	208-230/60/1	
COMPRESSOR AHA2490ZXD-AH556ET	047519-		1		512	MAIN	
+RELAY-START-COMPRESSOR	036047		1		103	208-230/60/1	
+CAPACITOR-START-135-155UF/33	036048		1		103	208-230/60/1	
+CAPACITOR-RUN- 35UF/440V	048132		1		103	208-230/60/1	
COMPRESSOR-M65B163BBCA	048258-			2	512	MAIN	
+CAPACITOR-START-161-193UF/250V	031790			2	103	208-230/60/1	
+RELAY-START-COMPRESSOR	037430			2	103	208-230/60/1	
+CAPACITOR-RUN- 25 UF/440V	037431			2	103	208-230/60/1	
COMPRESSOR TL3G-R134A	047701-	1	1	1	512	SHR	
CAPACITOR-START-60UF-220/275V	047703	1	1	1	103	208-230/60/1	
+KIT-MOUNTING-COMPRESSOR	047704	1	1	1	103		
+RELAY-START-COMPRESSOR-TL3G	047702-	1	1	1	103	208-230/60/1	
+COVER-TERMINAL	047739	1	1	1	103		
CONDENSER-AC-12LX18HX2.6T-3ROW	048233	1		2	103		
CONDENSER-AC-19X14X2.5-4ROW	048623		1		103		
CONDENSER-AC-7X6X1.25-2 ROW	027155	1	1	1	103	SHR	
COUPLING-DRIVE 3/4 HEX X 1-7/8	012721	2	2	2	103		
+SCREW-5/16-18 X 5/16 ALLEN SET	042511	4	4	4	000		
COVER A.-HOPPER *162-168*	X37963	1			103		
+GASKET-HOPPER COVER-8QT	037042	1			000		
+KNOB-MIX COVER	025429	1			103		
COVER A.-HOPPER-STD	X38458		2	2	103		
+GASKET-HOPPER COVER-20 QT-TWIN	038474		1	1	000		
+KNOB-MIX COVER	025429		2	2	103		
DECAL-CLEAN INST.-HOPPER	019029	1	1	1	000		
DECAL-DEC- 336 SOFTECH	038337	1			000		
DECAL-DEC-TWIN-SS	032919		1	1	000		

+ Available Separately

DESCRIPTION	PART NUMBER	336 QTY.	338 QTY.	339 QTY.	WARR. CLASS	REMARKS	PARTS UPDATE
DECAL-POWER SWITCH	032484	1	1	1	000		
DECAL-TROUBLESHOOTING	038374	1	1	1	000		
DEFLECTOR-BLOWER EXHAUST	048345	1			103		
DEFLECTOR-BLOWER EXHAUST	048586			1	103		
DIAGRAM-WIRING	038333	1			000		
DIAGRAM-WIRING	051624-		1		000		
DIAGRAM-WIRING	048585-			1	000		
DOOR A.-3 SPOUT	X51532-15	1	1	1	103		
+HANDLE A.-DRAW-ADJ.-STAINLESS	X33687	3	3	3	103		
+HANDLE-ADJUSTABLE	028804	3	3	3	103		
+O-RING-1/4 OD X .070W 50 DURO	015872	3	3	3	000		
+SCREW-ADJUSTMENT	026592	3	3	3	000		
+PLUG-PRIME	028805	2	2	2	103		
+O-RING-3/8 OD X .070W	016137	4	4	4	000		
+ROD A.-PIVOT	X20683	1	1	1	103		
+O-RING-5/16 OD X .070W	016272	1	1	1	000		
+VALVE A.-DRAW	X18303	3	3	3	103		
+O-RING-7/8 OD X .103W	014402	6	6	6	000		
DRYER-CAP. TUBE-HP62/R134A	047699	1	1	1	000	SHR	
DRYER-FILTER-HP62-3/8 X 1/4S	047521	1		2	000		
DRYER-FILTER-HP62-3/8 X 1/4S	048901		1		000		
EYELET-RESET BUTTON	013739	2		2	000		
FASTENER-CLIP 1/4-20 U-TYPE	045865	8	8	8	000	BASE PAN/PANELS	
GASKET-DOOR HT 4"-DOUBLE	048926	2	2	2	000		
GEAR A.*REDUCER	021286	2	2	2	212		
GUARD-FAN	028534-1		1		103		
GUIDE A.-DRIP PAN	X51567		1		103		
GUIDE A.-DRIP PAN	X27554	1			103		
GUIDE A.-DRIP PAN	X28699			1	103		
HOOD	041026	1			103		
HOOD	042866		1		103		
HOOD	035434			1	103		
KIT A.-TUNE UP-3 SPOUT-NON HT	X49463-6	1			000		
BEARING-FRONT	050216	2			000		
CAP-DESIGN-1.010"ID-6 POINT	014218	3			000		

+ Available Separately

DESCRIPTION	PART NUMBER	336 QTY.	338 QTY.	339 QTY.	WARR. CLASS	REMARKS	PARTS UPDATE
GASKET-DOOR HT 4"-DOUBLE	048926	2			000		
O-RING-.563 OD X .070W-#013	043758	8			000		
O-RING-3/8 OD X .070W	016137	6			000		
O-RING-5/16 OD X .070W	016272	1			000		
O-RING-7/8 OD X .BW	014402	7			000		
SEAL-DRAW VALVE	034698	1			000		
SEAL-DRIVE SHAFT	032560	2			000		
TOOL-CLEANING O-RING REMOVAL	048260	1			000		
KIT A. -TUNE UP-3 SPOUT- NON HT	X49463-4		1	1	000		
BEARING-FRONT	050216		2	2	000		
CAP-DESIGN-1.010"ID-6 POINT	014218		3	3	000		
GASKET-DOOR HT 4"-DOUBLE	048926		2	2	000		
O-RING-.643 OD X .077W	018572		8	8	000		
O-RING-3/8 OD X .070W	016137		6	6	000		
O-RING-5/16 OD X .070W	016272		1	1	000		
O-RING-7/8 OD X .103W	014402		7	7	000		
SEAL-DRAW VALVE	034698		1	1	000		
SEAL-DRIVE SHAFT	032560		2	2	000		
TOOL-CLEANING O-RING REMOVAL	048260		1	1	000		
LABEL-DOOR CAUTION	032749	1	1	1	000		
LABEL-MOVING PARTS WARN	024315	3	3	3	000		
LABEL-WARNING PANEL	036529	3	3	3	000		
LEG-4" SS-W/ORING	013458		4		103		
LOUVER-SIDE	017471	2	1	2	103	MODEL 338 - LEFT SIDE	
LUBRICANT-TAYLOR 4 OZ.	047518	1	1	1	000		
MAN-OPER 300 SERIES SOFTECH	036029-M	1	1	1	000		
MOTOR-1.0 HP	013102-	2	2	2	212		
MOTOR-FAN 80 W 208/230V 60HZ	051744-		1		103	MAIN SYSTEM	
+CAPACITOR-RUN- 4UF-440V	051785		1		103		
+FAN-5 BLADE 12"PUSH 32DEG CC	047279		1		103		
MOTOR-FAN 105CFM 3000RPM	027309-	1	1	1	103	SHR	
NUT-STUD *460-664-754-56*LONG	034382	2	2	2	103		
NUT-STUD *460-664-754-56*SHORT	034383	2	2	2	103		
ORIFICE	022465-100	2	2	2	103		
+O-RING-3/8 OD X .070W	016137	2	2	2	000		

+ Available Separately

DESCRIPTION	PART NUMBER	336 QTY.	338 QTY.	339 QTY.	WARR. CLASS	REMARKS	PARTS UPDATE
PAIL-MIX 6 QT.	023348		1		000		
PAIL-MIX 10 QT.	013163	1		1	000		
PAN A.-DRIP - 17-1/4" LONG	027504	1		1	103	SIDE PANEL MOUNT	
PAN A.-DRIP - 15-1/8" LONG	X51601		1		103	FRONT PANEL MOUNT	
PAN A.-DRIP HINGED	X41844		1		103	INTERNAL MOUNT	
PANEL A.-FRONT	X42821-SP1	1			103		
PANEL A.-FRONT	X51590		1		103		
PANEL A.-FRONT	X32956			1	103		
PANEL A.-LOWER SIDE	X24424	2		2	103	RIGHT & LEFT	
PANEL A.-SIDE LEFT	X51596		1		103		
PANEL A.-SIDE RIGHT	X48596		1		103	UPPER	
PANEL-SIDE- RIGHT	048487		1		103	LOWER	
PANEL-REAR	029816	1			103		
PANEL-REAR	017563			1	103		
PANEL-REAR	051600		1		103		
PANEL-SERVICE	042824	1			103		
PANEL-SERVICE	024439			1	103		
PANEL-UPPER SIDE LEFT	028740	1		1	103		
PANEL-UPPER SIDE RIGHT	028741	1		1	103		
PLATE-DEC-336*	038081	1			103		
PLATE-DEC-754-755	032961		1	1	103		
PLUG-DRIP TRAY HOLE	029595	1		1	000		
PROBE A.-MIX *SQUARE*	X30922	2	2	2	103		
PROBE A.-THERMISTOR	X31602	2	2	2	103	BARREL	
PROBE A.-THERMISTOR	X34466	1			103	HOPPER	
PROBE A.-THERMISTOR/RESISTOR	X50717		1	1	103	HOPPER	
PULLEY-2AK20 X 5/8 BORE	034238	2	2	2	103	BEATER MOTOR	
PULLEY-2AK64-5/8 BORE	039695	2	2	2	103	GEAR	
RECEPTACLE A.- QUICK CONNECT	X33321		2	2	103	DRAW SWITCH	
RELAY-3 POLE-20A-208/240 50/60	012725-	1	1	2	103	COMPRESSOR	
RELAY-SPDT-30 A-240 V	032607-	1		1	103	BLOWER MOTOR	
SANITIZER KAY-5 125 PACKETS	041082		1	1	000		
SANITIZER-STERA SHEEN-GREEN	065293	1			000		
SHAFT-BEATER	032335	2	2	2	103		
+SEAL-DRIVE SHAFT	032560	2	2	2	000		

+ Available Separately

071018

DESCRIPTION	PART NUMBER	336 QTY.	338 QTY.	339 QTY.	WARR. CLASS	REMARKS	PARTS UPDATE
SHELL A.-INSULATED	X37091-SP	1			512		
+STUD-NOSE CONE	022822	4			103		
SHELL A.-INSULATED	X50770		1	1	512		
+STUD-NOSE CONE	022822		4	4	103		
SHIELD-SPLASH 23 L	022766	1	1	1	103		
SKIRT-AIR FLOW	048489		1		103		
+COLLAR-HOLDING	019481		3		103		
+SCREW-HOLDING COLLAR (10-32x3/4 OVAL)	001086		3		000		
STARTER	041950-	2	2	2	103		
SWITCH A.-DRAW *336*SELF CLOSE	X43417-SER	1			103		
ARM-SWITCH-DRAW-LEFT	038649	1			103		
ARM-SWITCH-DRAW-RIGHT	038650	1			103		
BRACKET A.-SPRING RETURN	X38257	1			103		
E-RING 1/4	032190	4			000		
PIN-PIVOT-DRAW SWITCH	038484	1			103		
SPRING-EXTENSION.375X.045X1.00	038922	2			103		
SPRING-RETURN-LEFT-TWIN TWIST	038923	1			103		
SPRING-RETURN-RIGHT-TWIN TWIST	038924	1			103		
SWITCH A.-DRAW-TWIN TWIST	X39269	1			103		
BRACKET-DRAW SWITCH-TWIN TWIST	039264	1			103		
SWITCH-LEVER-SPDT-11A-125-277V	039252	2			103		
SWITCH A.-DRAW *SELF CLOSING*	X38547		1	1	103		
ARM-SWITCH-DRAW-LEFT	038649		1	1	103		
ARM-SWITCH-DRAW-RIGHT	038650		1	1	103		
BRACKET A.-SPRING RETURN	X38257		1	1	103		
BRACKET A.-SWITCH *338-39-754	X38252		1	1	103		
E-RING 1/4	032190		4	4	000		
PIN-PIVOT-DRAW SWITCH	038484		1	1	103		
ROD-SPRING RETAINER	038254		1	1	103		
SCREW-8-32X3/8 HEX HD TYPE 23	039267		2	2	000		
SPRING-EXTENSION.375X.045X1.00	038922		2	2	103		
SPRING-RETURN-LEFT-TWIN TWIST	038923		1	1	103		
SPRING-RETURN-RIGHT-TWIN TWIST	038924		1	1	103		
SWITCH A.-DRAW-TWIN TWIST	X39269		1	1	103		
BRACKET-DRAW SWITCH-TWIN TWIST	039264		1	1	103		

+ Available Separately

DESCRIPTION	PART NUMBER	336 QTY.	338 QTY.	339 QTY.	WARR. CLASS	REMARKS	PARTS UPDATE
SCREW-4-40 X1/2" TAPTITE PAN HD	042604		4	4	000		
SWITCH-LEVER-SPDT-11A-125-277V	039252		2	2	103		
SWITCH-PRESSURE 440 PSI- SOLDER	048230	1	1	2	103		
SWITCH- TOGGLE-4PDT*ON-NONE-ON	037394	1	1	1	103		
TRAY-DRIP 16-7/8L X 5-1/8	020157	1			103		
TRAY-DRIP 22-7/8L X 5-1/8W	014533		1	1	103		
TRIM-FRONT	051595		1		103		
TRIM-REAR CORNER LEFT	013761	1		1	103		
TRIM-REAR CORNER LEFT	044280		1		103		
TRIM-REAR CORNER RIGHT	013663	1		1	103		
TRIM-REAR CORNER RIGHT	044281		1		103		
TUBE-FEED 5/32 DIA. HOLE	043461-2	2			103		
+O-RING-.563 OD X .070W #013	043758	8			000		
TUBE A.-FEED-SS-5/32 HOLE DIA	X29429-2		2	2	103		
+O-RING-.643 OD X .077W	018572		8	8	000		
VALVE-ACCESS 1/4 X 3/8 SOLDER	029406	1		1	103		
VALVE-ACCESS 1/4FL X 1/4SOLDER	044404	1	1	1	103		
VALVE-ACCESS 1/4FL X 3/8SOLDER	043232		1	2	103		
VALVE-ACCESS-1/4 MFLX1/4 S-90	047016	1	2	2	103		
VALVE-EPR 1/4S	022665	1	1	1	103		
VALVE-EXP-AUTO-1/4S X1/4 FPT	046365	2	2		103		
VALVE-EXP-AUTO-1/4S X 1/4FPT	047232			2	103		
VALVE-SOLENOID 7/16 ORF 5/8ODF	048626-	2	2		103		
VALVE-SOLENOID 7/64ORF X 1/4S	043449-	2	2		103		
VIDEO-TRAIN FILM-SS-SOFTTECH	038047-V	1	1	1	000		
WASHER-PLASTIC PIVOT	013808	4		4	000		
WATER COOLED							
BLOWER-100 CFM	012796-	1		1	103		
CONDENSER-W/C COAX	047540	1			103		
CONDENSER-WC-SPIRAL 11-1/2	049309		1		103		
CONDENSER-W/C COAX	048287			2	103		
GUARD-BLOWER	022505	1		1	103		
MOTOR-FAN-25W 230V	015184-		1		103		
+FAN-5 BLADE 10" PUSH	013043		1		103		
OUTLET A.-TEE	X25900			1	103		

+ Available Separately

DESCRIPTION	PART NUMBER	336 QTY.	338 QTY.	339 QTY.	WARR. CLASS	REMARKS	PARTS UPDATE
SWITCH-PRESSURE 350PSI-SOLDER	048231	1	1	2	103		
VALVE-WATER 3/8 REG\HEAD PRESS	008363				103		
VALVE-WATER 3/8 REG\HEAD PRESSURE	046686	1	1	2	013		
50Hz							
BELT-AX33	024396			4	000		
BELT-AX39	023874	4			000		
BLOCK-TERMINAL 2 POLE	039421			2	103	220-240/50/1	
BLOCK-TERMINAL-2 POLE	039422	2			103		
BLOCK-TERMINAL-7 POLE GREEN	024156	1			103		
COMPRESSOR COMPONENTS							
CAPACITOR-RUN 25UF/370VOLT	023739	1			103	220-240V 50HZ 1PH	
CAPACITOR-START	031790	1			103	220-240V 50HZ 1PH	
RELAY-START-COMPRESSOR	038146	1			103	220-240V 50HZ 1PH	
CAPACITOR-RUN- 35UF/370V	029439		1		103	220-240V 50HZ 1PH	
CAPACITOR-START-135-155UF/33	036048		1		013	220-240V 50HZ 1PH	
RELAY-START-COMPRESSOR	036047		1		103	220-240V 50HZ 1PH	
CAPACITOR-RUN	035734			2	103	220-240V 50HZ 1PH	
CAPACITOR-START	031790			2	103	220-240V 50HZ 1PH	
RELAY-START COMPRESSOR	048764			2	103	220-240V 50HZ 1PH	
DIAGRAM-WIRING	038333-34	1			000		
DIAGRAM-WIRING	051624-40		1		000		
DIAGRAM-WIRING	046585-34			1	000		
PULLEY 2AK25 X .625	021076	2	2	2	103	BEATER MOTOR	
VIDEO- TRAIN FILM-SS-SOFTECH	038047-PAL	1	1	1	000		

+ Available Separately

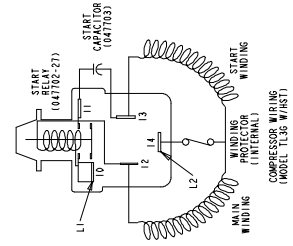
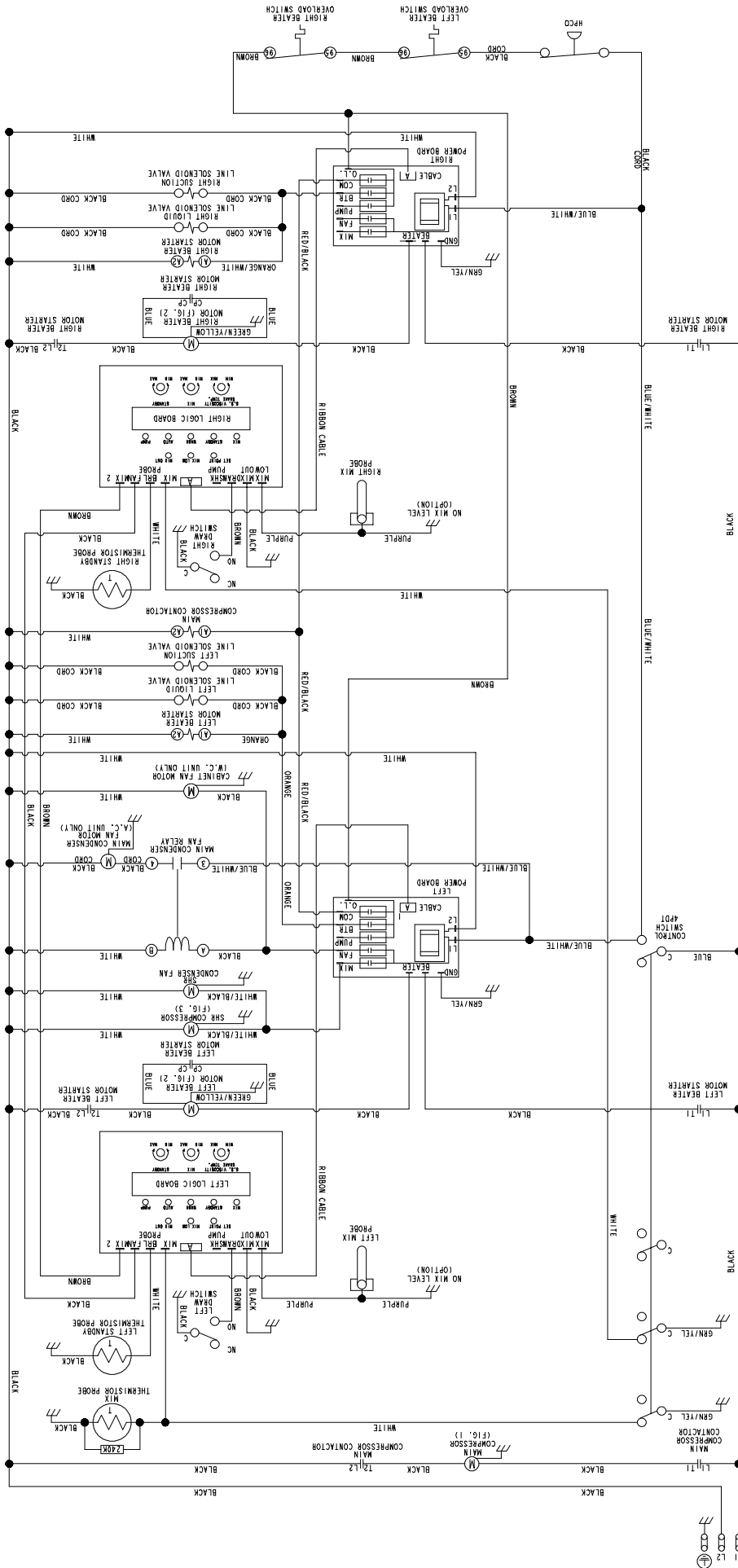

FIG. 3

GROUND FRAME SECURELY

MARKETER BEATER MOTOR WIRING

- STEPS: 1) MOVE BROWN WIRE FROM BEATER TERMINAL #1 TO TERMINAL #5
- 2) MOVE BLUE INTERNAL FROM MOTOR MAIN WINDING
- 3) MOVE BLUE INTERNAL FROM MOTOR MAIN WINDING
- 4) MOVE BLUE INTERNAL FROM MOTOR MAIN WINDING
- 5) MOVE BLUE INTERNAL FROM MOTOR MAIN WINDING

- NOTE: FOR CABLE - BLUE INTERNAL ON #1, YELLOW INTERNAL ON #6

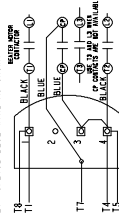

LESON BEATER MOTOR WIRING

- STEPS: 1) DISCONNECT WIRE T7 FROM TERMINAL 3
- 2) SPlice BLUE WIRE AS SHOWN

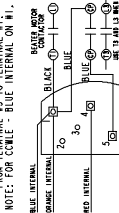

FIG. 2

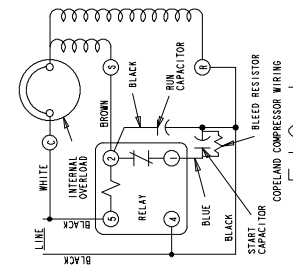
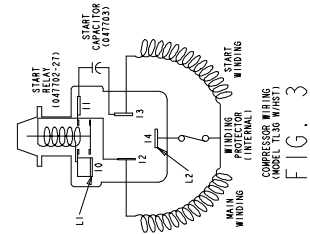
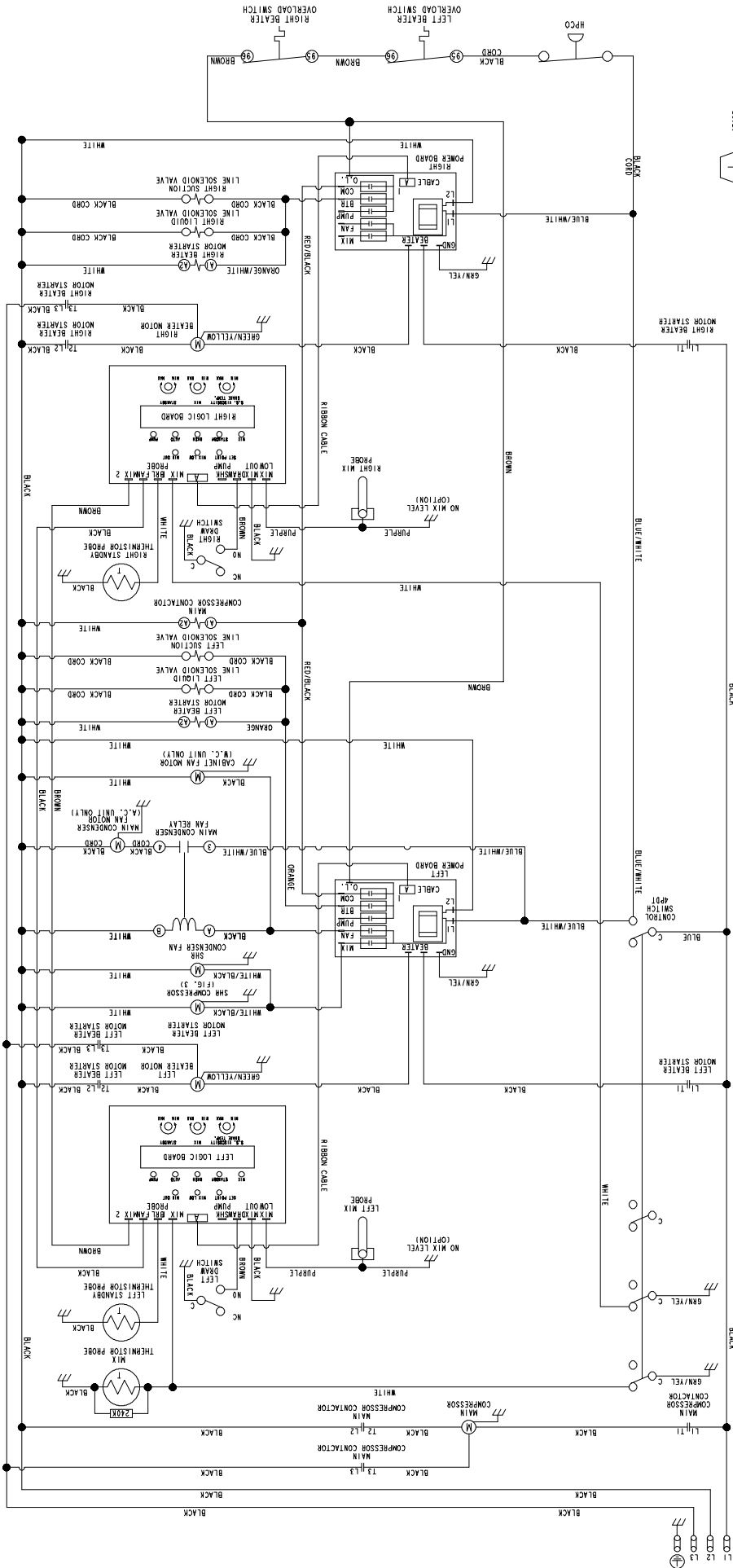

FIG. 1

Model 336
038333
Rev. 11/02



GROUND FRAME SECURELY
 COMPRESSOR AND BLOWER MOTORS PROTECTED
 UNDER PRIMARY SINGLE PHASING CONDITIONS

Model 336
038333-33
Rev. 11/02

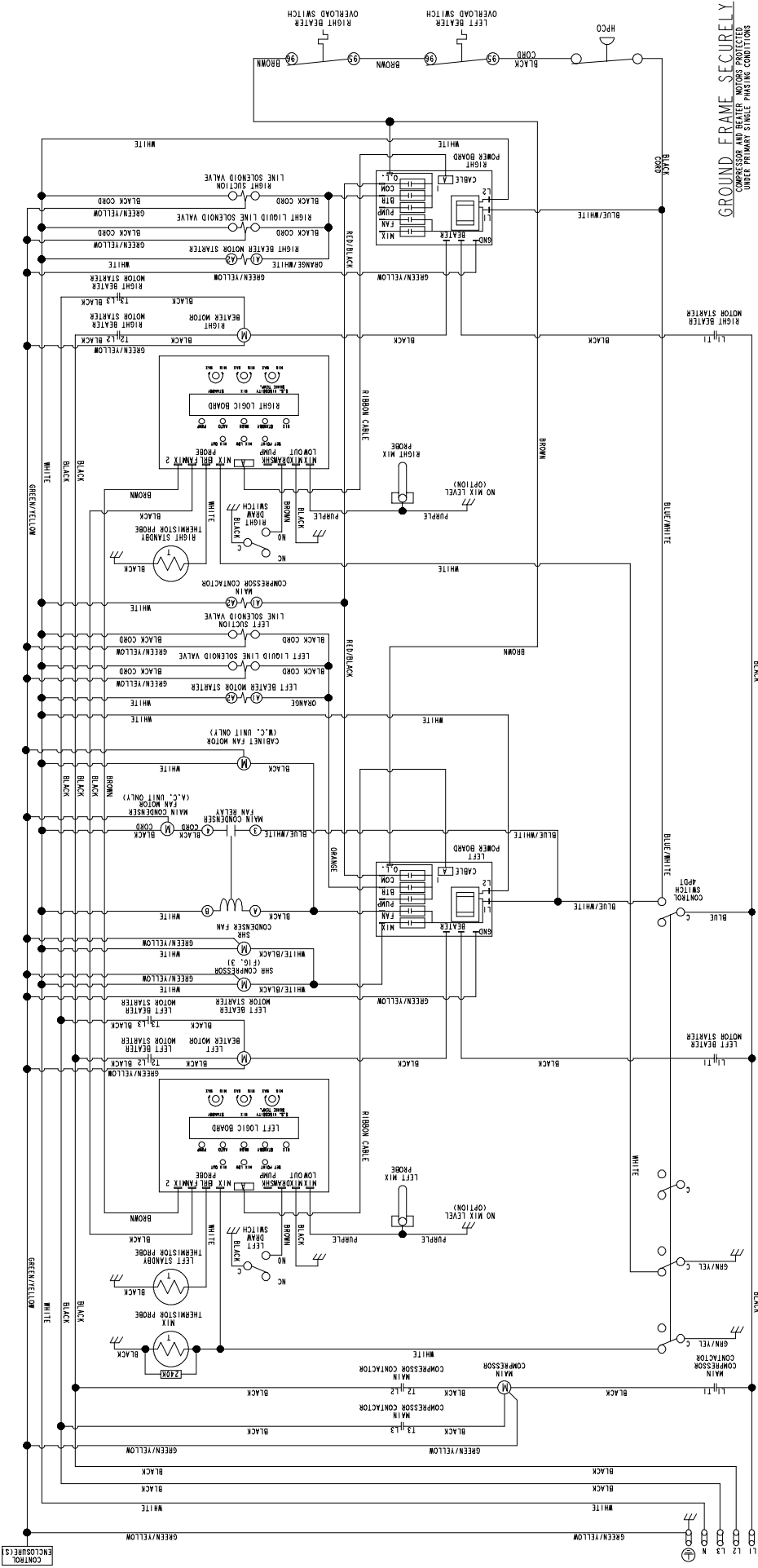

GROUND FRAME SECURELY
 COMPRESSOR AND BEATER MOTOR PROTECTED
 UNDER PRIMARY SOURCE FAULT CONDITIONS

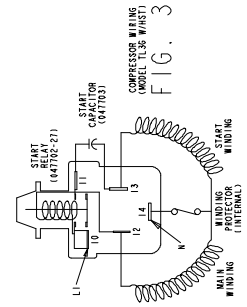

Model 336
038333-62
Rev. 11/02

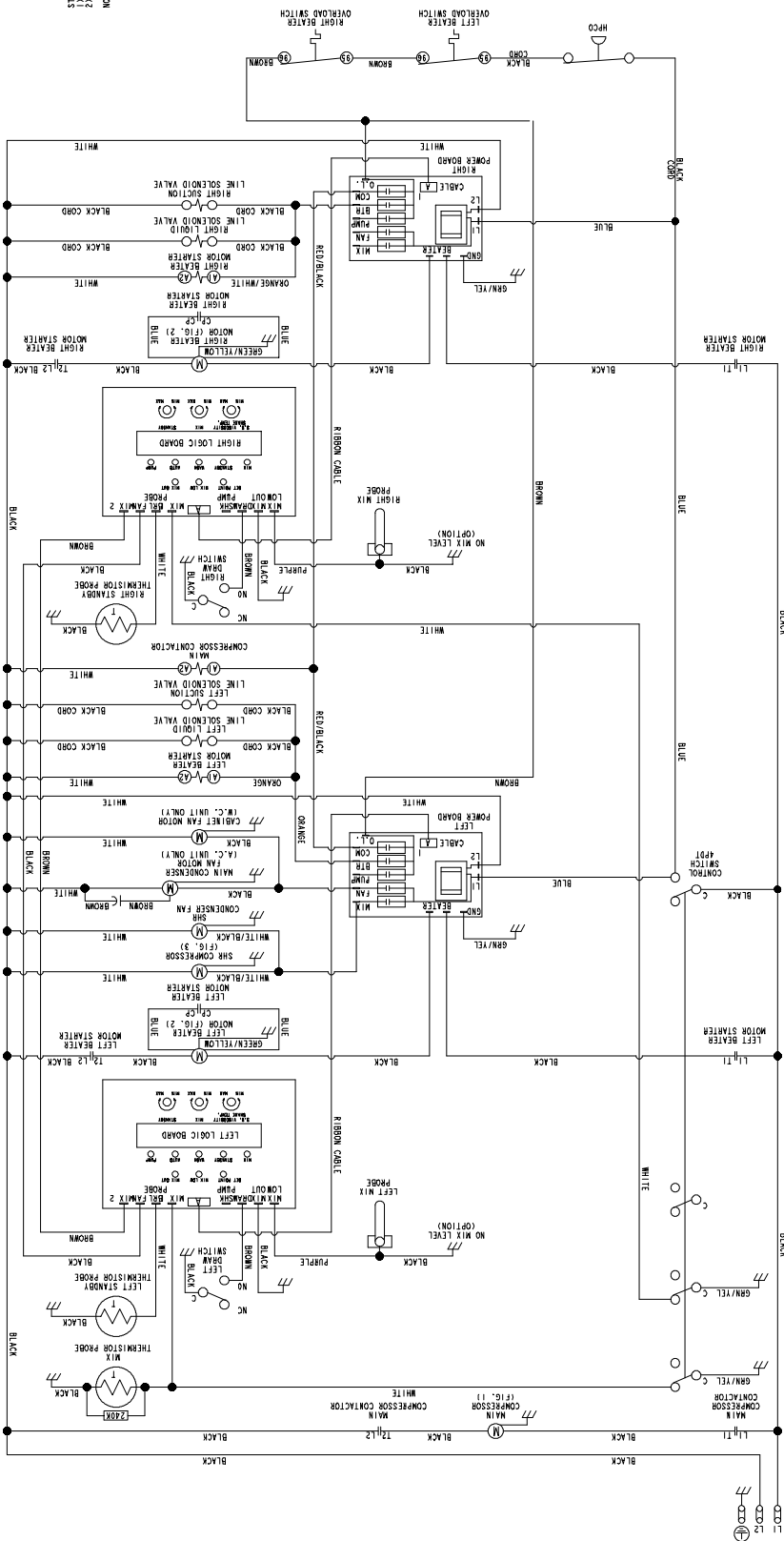

MAGNETIC BEATER MOTOR WIRING
 STEPS:
 1) REMOVE BROWN JUMPER BETWEEN TERMINAL #1 TO TERMINAL #5
 2) REMOVE BLUE INTERNAL WIRE FROM MOTOR MAIN WINDING
 3) REMOVE YELLOW INTERNAL WIRE FROM MOTOR MAIN WINDING
 NOTE: FOR COILS - BLUE INTERNAL ON #1, YELLOW INTERNAL ON #6

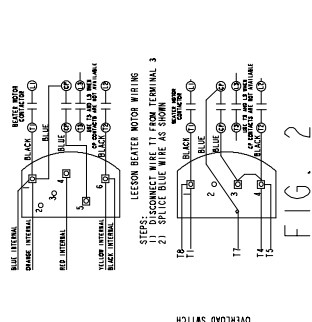

FIG. 2

GROUND FRAME SECURELY
 COMPRESSOR AND BEATER MOTORS PROTECTED
 UNDER PRIMARY SINGLE PHASING CONDITIONS

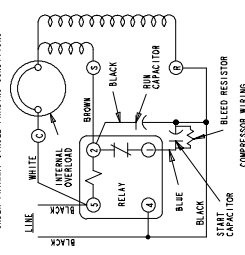

FIG. 1

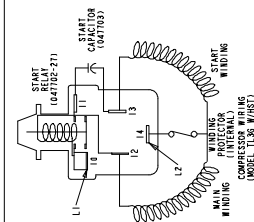
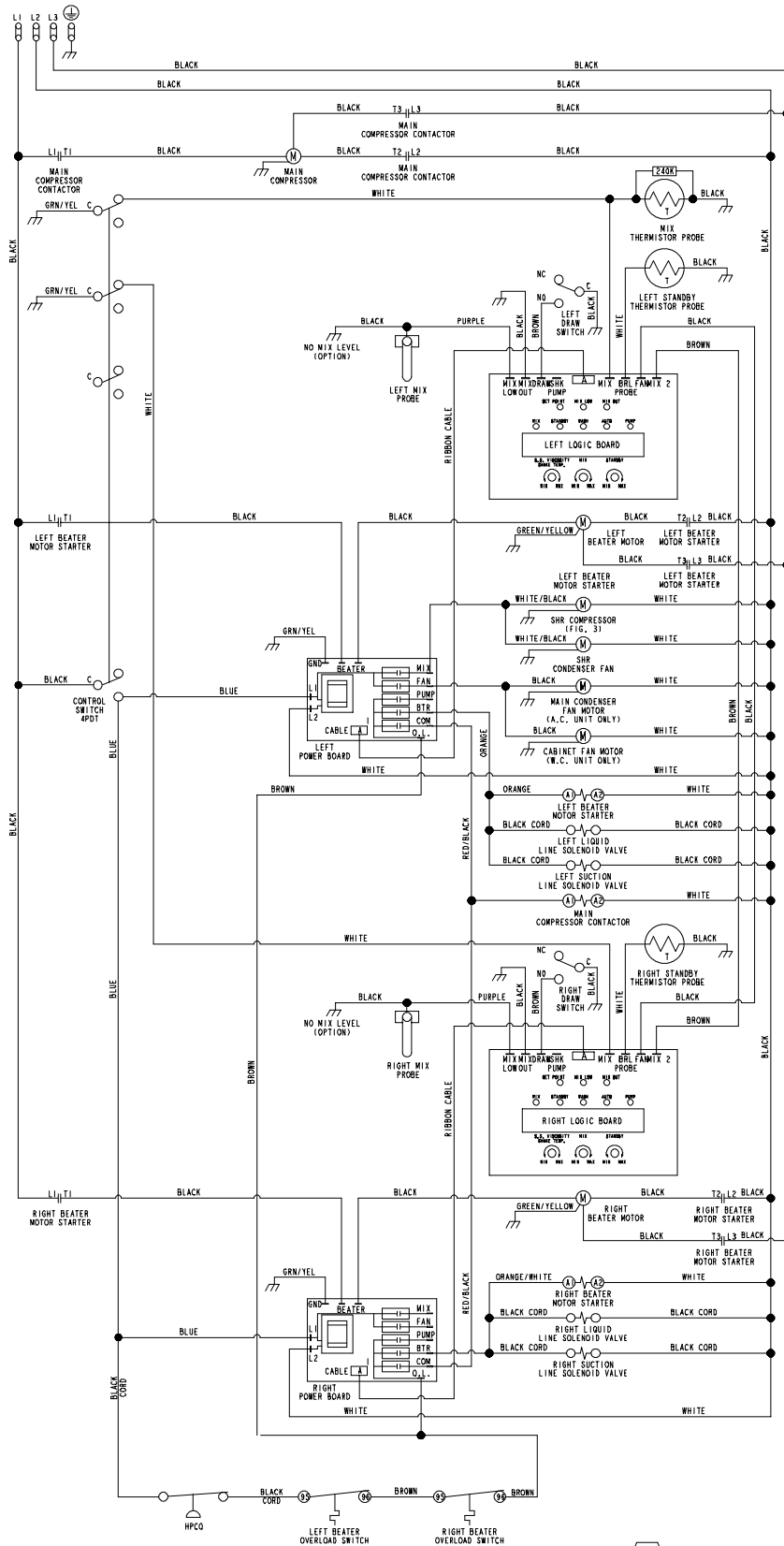
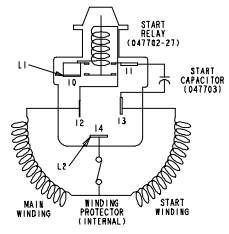

FIG. 3



GROUND FRAME SECURELY
 COMPRESSOR AND BEATER MOTORS PROTECTED
 UNDER PRIMARY SINGLE PHASING CONDITIONS



COMPRESSOR WIRING
 (MODEL TL36 W/HST)
 FIG. 3

Model 338
051624-33
Rev. 11/02

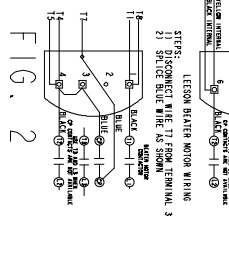
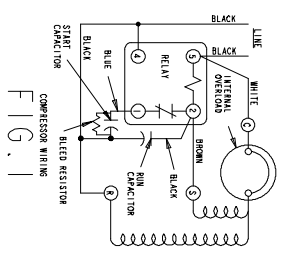
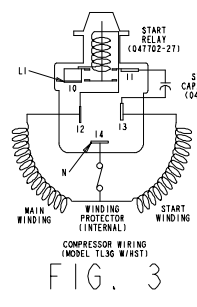
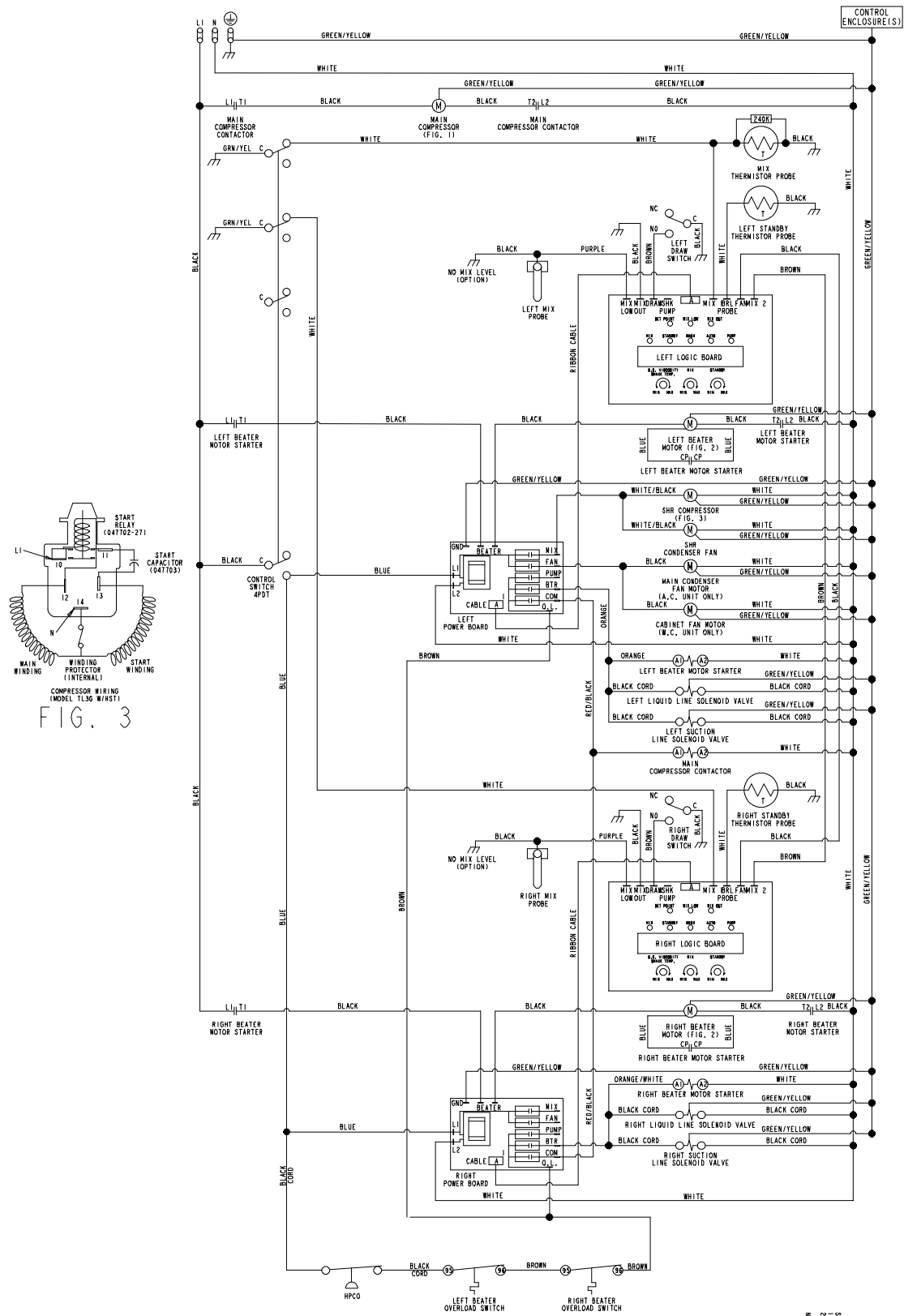

STEPS: MONITOR BEATER MOTOR WIRING
 1) REMOVE BROWN WIRE FROM BEATER MOTOR TERMINAL 1 TO TERMINAL 25
 2) FROM TERMINAL 25 TO TERMINAL 21
 NOTE: FOR CABLE BLUE INTERNAL ON 81, YELLOW INTERNAL ON 82

GROUND FRAME SECURELY
 COMPRESSOR AND BEATER MOTORS PROTECTED UNDER PRIMARY SINGLE PHASING CONDITIONS

Model 338
051624-40
Rev. 11/02

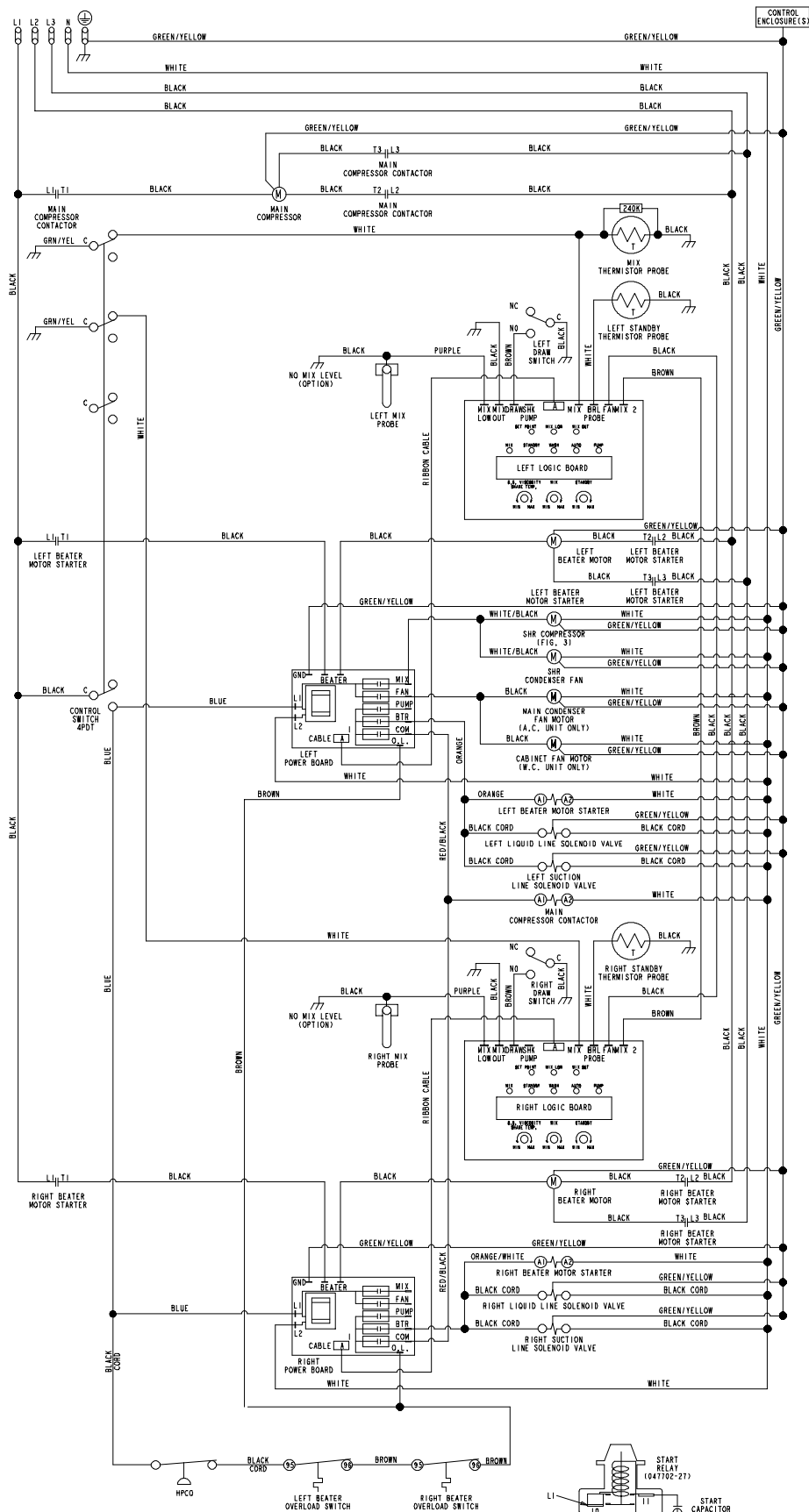

GROUND FRAME SECURELY
 COMPRESSOR AND BEATER MOTORS PROTECTED
 UNDER PRIMARY SINGLE PHASING CONDITIONS

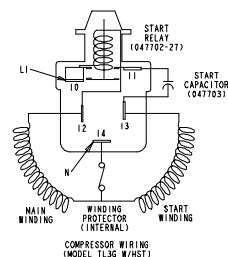
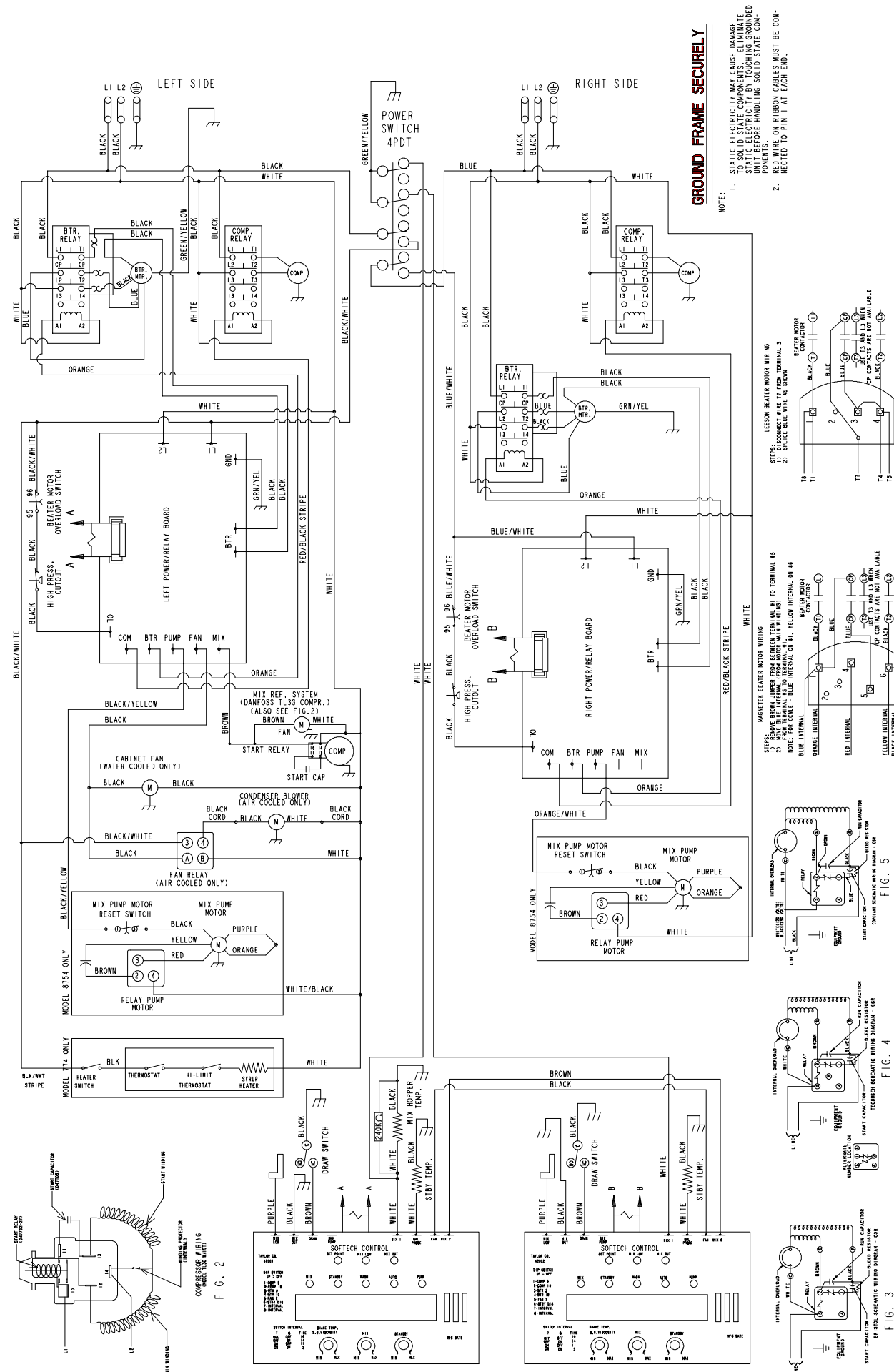

FIG. 3

Model 338
051624-58
Rev. 11/02



GROUND FRAME SECURELY

- NOTE:
1. STATIC ELECTRICITY MAY CAUSE DAMAGE TO SOLID STATE COMPONENTS. DISCHARGE ALL STATIC ELECTRICITY FROM THE UNIT BEFORE HANDLING SOLID STATE COMPONENTS.
 2. RED WIRE ON RIBBON CABLES MUST BE CONNECTED TO PIN 1 AT EACH END.

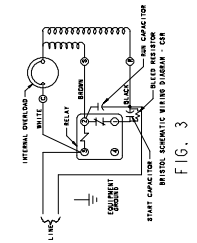
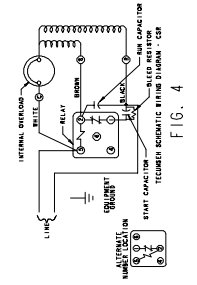
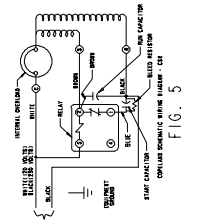
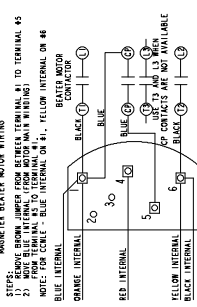
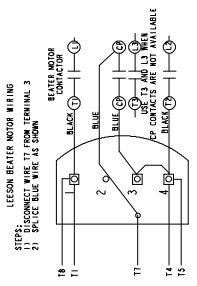
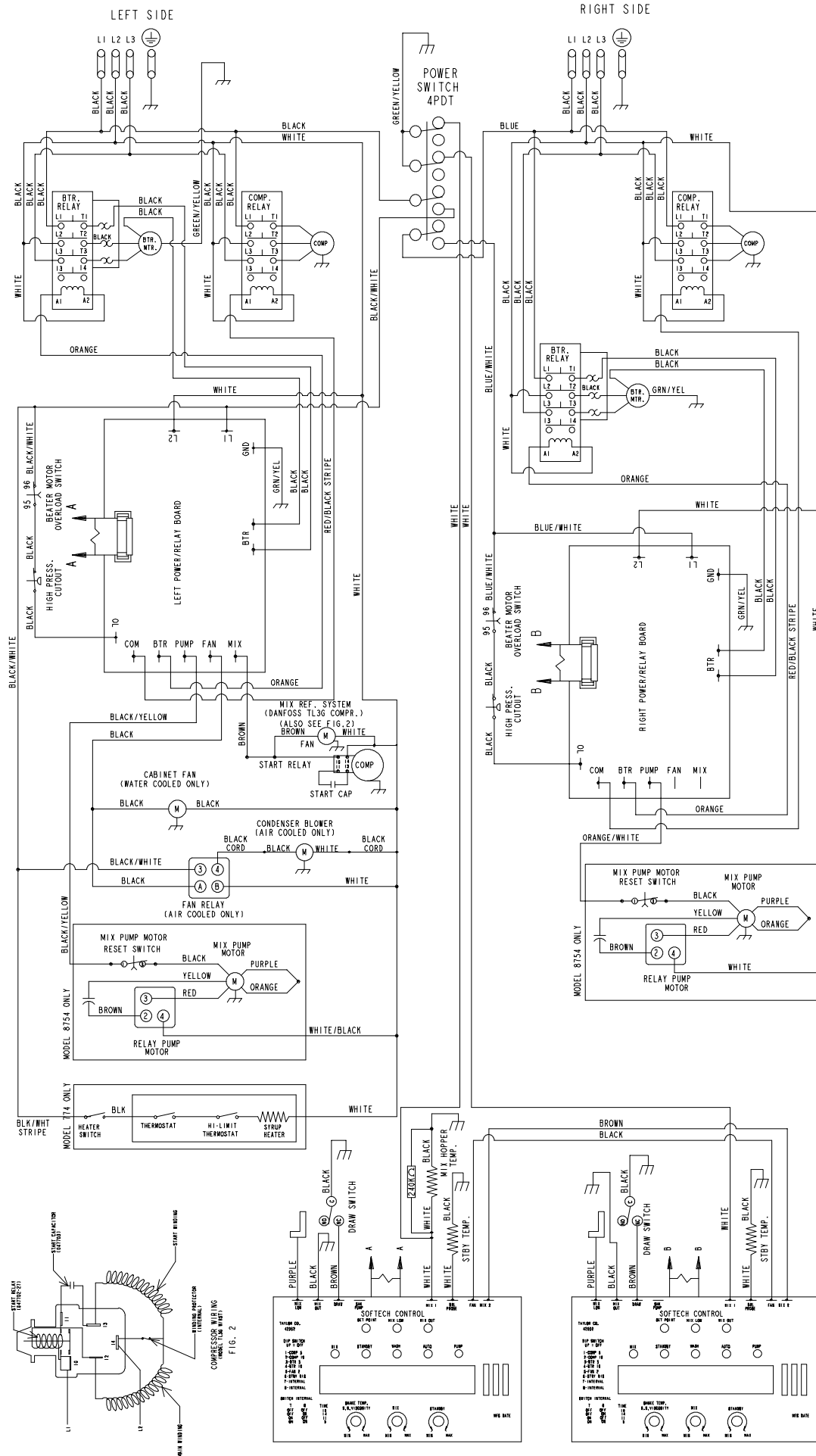

FIG. 2

FIG. 5

FIG. 4

FIG. 3



Model 339
046585-33
Rev. 11/02

LEFT SIDE

RIGHT SIDE

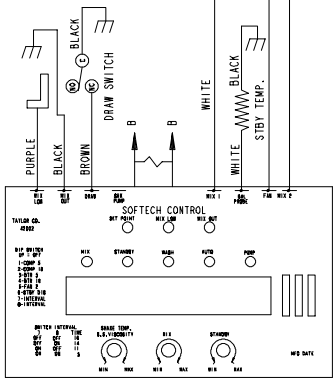
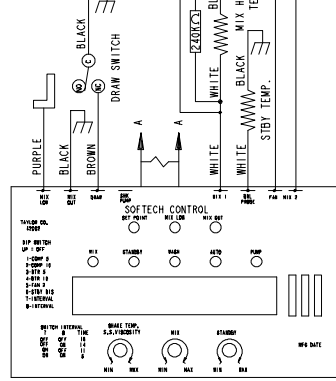
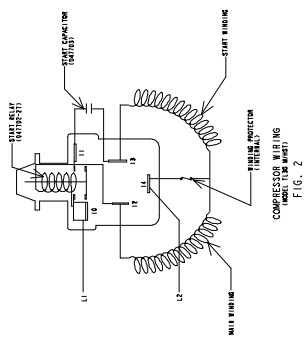
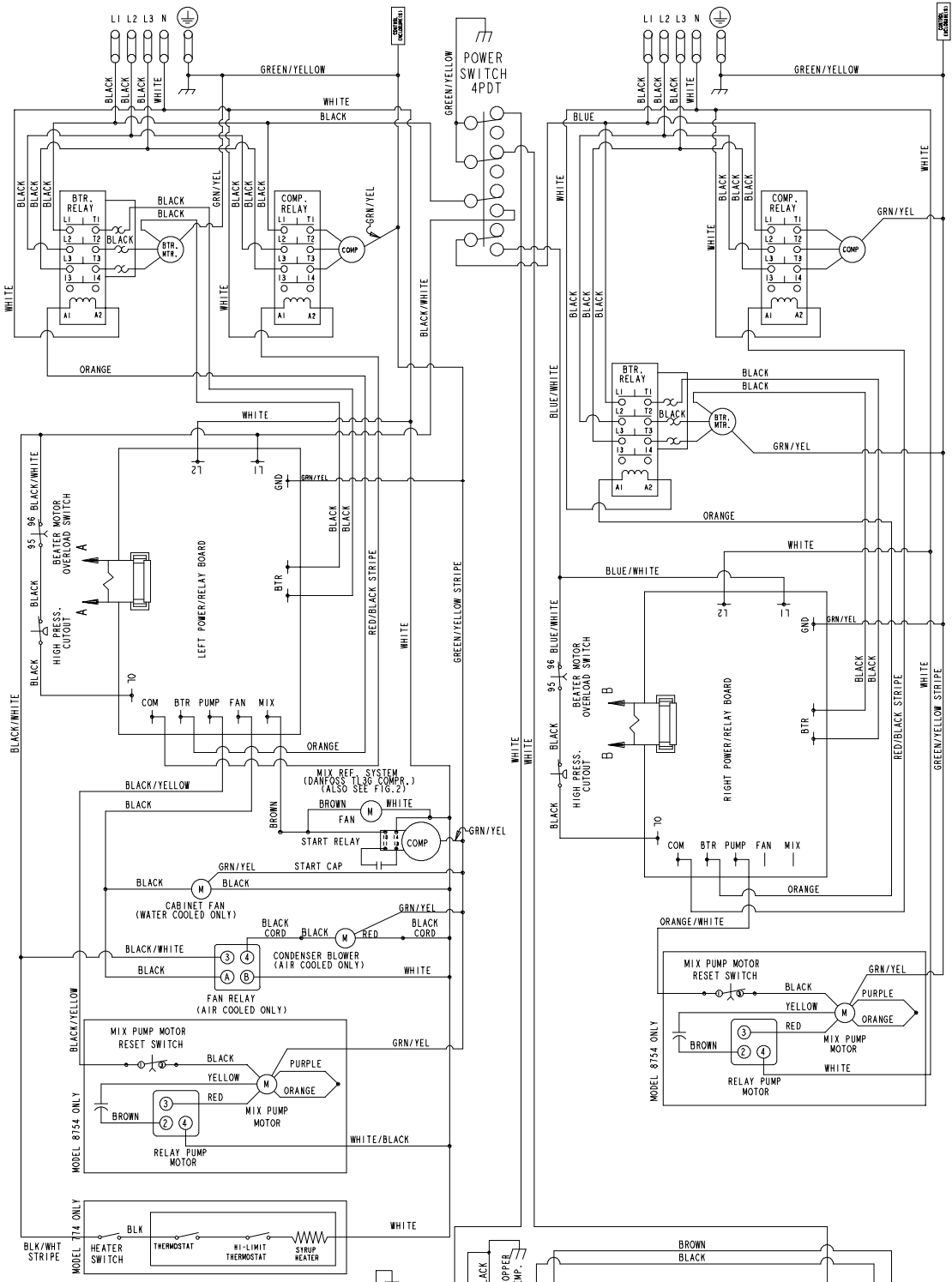

COMPRESSOR AND BEATER MOTOR PROTECTED UNDER PRIMARY SINGLE PHASING CONDITIONS

GROUND FRAME SECURELY

Free Manuals Download Website

<http://myh66.com>

<http://usermanuals.us>

<http://www.somanuals.com>

<http://www.4manuals.cc>

<http://www.manual-lib.com>

<http://www.404manual.com>

<http://www.luxmanual.com>

<http://aubethermostatmanual.com>

Golf course search by state

<http://golfingnear.com>

Email search by domain

<http://emailbydomain.com>

Auto manuals search

<http://auto.somanuals.com>

TV manuals search

<http://tv.somanuals.com>