

# Installation Instructions

479

Sizes 180 & 240  
Series D

ALL WEATHER HEATING and COOLING UNIT

**bryant**

Cancels: 39479D6

39479D8  
9/20/71

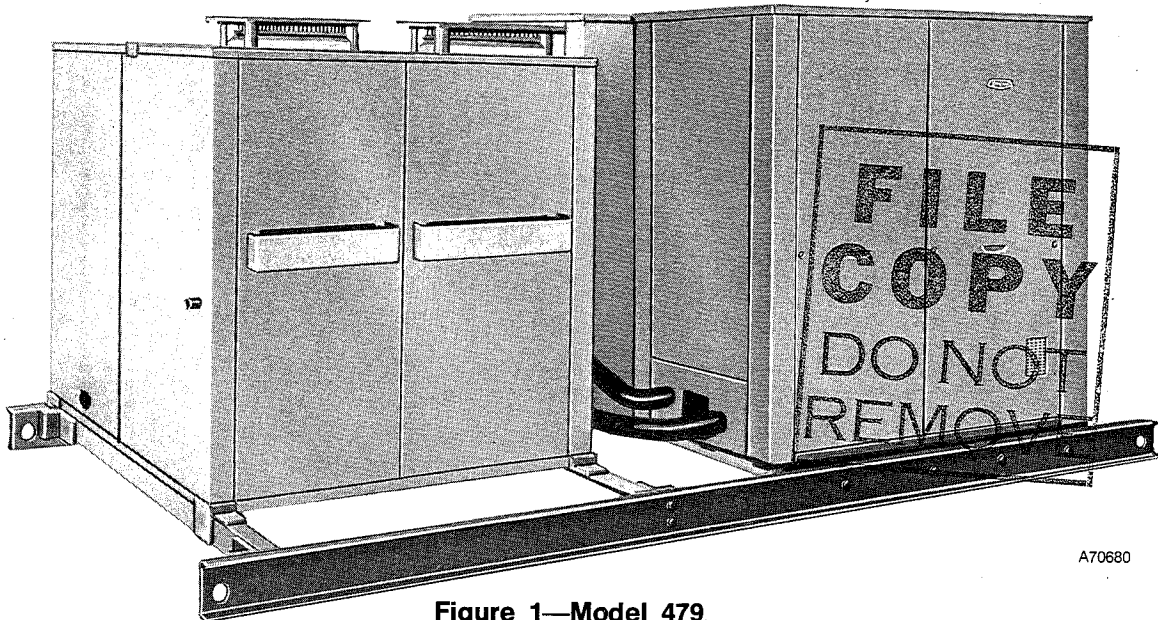

A70680

Figure 1—Model 479.

## Important - Read before Installing

1. Check all local or other applicable codes for information concerning proximity to property lines, height above roof, obstructions, etc.
2. Be sure the power supply available (voltage, frequency and phase) corresponds to that specified on the unit.
3. Check the electrical service provided by the utility for the building to be sure that the service capacity is sufficient to handle the load imposed by this unit.
4. Refer to the regulations of the serving gas supplier and the local building, heating, plumbing or other codes in effect in the area in which installation is to be made.
5. Refer to the dimensional drawing on page 2 for electrical, gas, duct and drain connections prior to setting the unit in place.

## GENERAL

The Bryant Model 479 is an all weather heating and cooling unit designed for outdoor installation only. It can be installed at ground level or on a rooftop. The 479 is factory assembled, pre-wired and charged with

the primary refrigerant. Installation consists of the following:

- I. Locating the Unit
- II. Installing Vent Caps
- III. Duct Connections
- IV. Gas Connections
- V. Electrical Connections
- VI. Chilled Water System
- VII. Start-Up and Adjustments
- VIII. Furnace Operation
- IX. Cooling Operation
- X. Maintenance

*Read the entire Installation Instructions before starting installation.*

## I. LOCATE AND MOUNT THE UNIT

The condenser air discharges upward; therefore, avoid locations where obstructions will deflect the hot condenser discharge air back into the condenser inlet air supply. In all cases, the condenser should be at least 2 feet from any wall or obstruction and outside of the plumb line from any overhang.

Use caution to prevent damage when moving the unit. Use an adequate rope or cable sling and keep the unit in an upright position at all times during rigging and moving operations.

**CAUTION:** Protect the top and sides so that the rigging sling will not damage the unit.

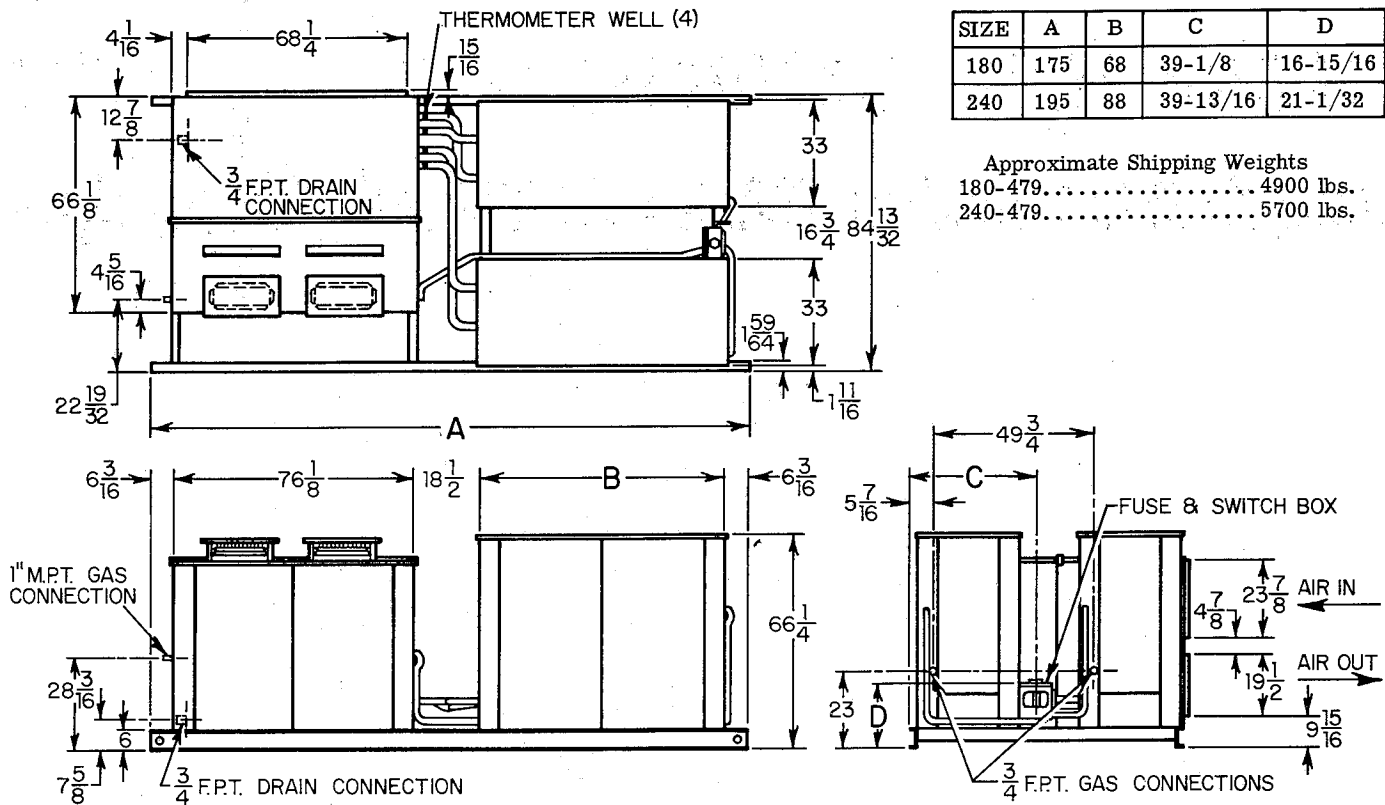

Figure 2—Dimensional Drawing

A70224

TABLE I  
HEATING RATINGS and CAPACITIES 180/240-479

Input 1st Stage	Btuh	225,000
Output 1st Stage	Btuh	168,000
Input 1st and 2nd Stage	Btuh	450,000
Output 1st and 2nd Stage	Btuh	337,000
Approved Temp Rise		
Model 180-479	°F	45 - 75
Model 240-479	°F	20 - 50

TABLE II  
COOLING RATINGS and CAPACITIES

MODEL		180-479	240-479
Capacity (Total Cooling)	Btuh	180,000	240,000
Air Flow	CFM	6,000	8,000
External Static Pressure	In. wg.	0.3	0.4
Entering Air Temperature	°F	80/67	80/67
Entering Water Temperature	°F	45	45
Gas Input (Total)	Btuh	450,000	600,000
Electrical Input (Total)	KW	5.0	6.0
Refrigerant	Type	R717	R717
Amount per Chiller	Lbs.	18	26
Total Solution per Chiller	Lbs.	55	79

## Mounting Bases

The mounting base should comply with local codes and be made of noncombustible material. The recommended types of mounting bases for all installations are:

- Precast concrete lintels.** Use three lintels run the depth of the unit; one under the right end, one under the left end, and one at the center of the unit.
- Steel beams.** Use three I-beams run the depth of the unit; one under each end and one at the center.
- Concrete Slab.** A minimum thickness of four inches is required.

## Rooftop Installation

When installing the 479 on a roof or other combustible material, use noncombustible supports and allow a 6 inch clearance beneath the unit's subbase for proper air circulation. Be sure the roof construction will support the weight of the equipment. Locate the unit above a load-bearing wall whenever possible.

## Condensate Drain

The 479 is furnished with a 3/4 inch FPT drain connection. If the installation requires draining the condensate away from the roof of the building, connect tubing, pipe, hose or trough and pitch downward one inch for every ten feet of horizontal run.

## Ground Level Installation

The 479 should be placed on a concrete slab at least 4 inches thick. Level the unit on the slab and be sure there is adequate drainage away from its base.

## Clearances

The minimum clearances are 6 inches from the duct side and 24 inches from all other sides.

## II. INSTALLING VENT CAPS

The vent cap assemblies are packaged and shipped in the heating section coil compartment. Install the vent cap assemblies as follows. See Figure 3.

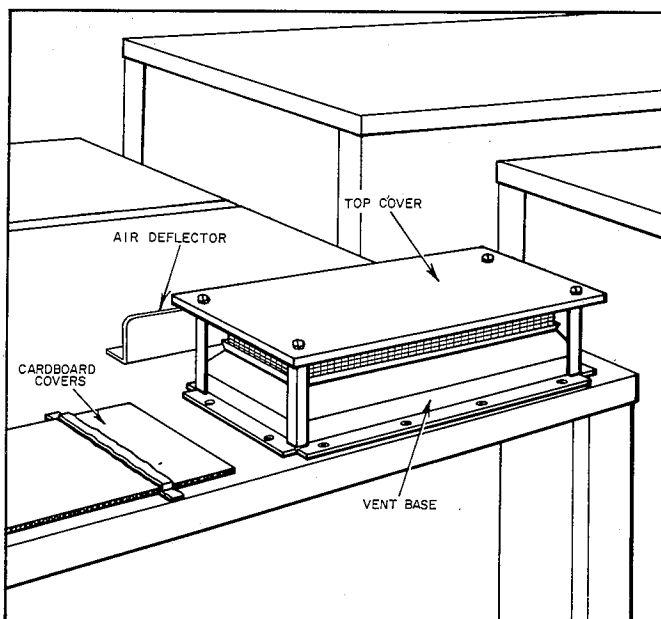

Figure 3—Installing Vent Caps

1. Remove the cover on each of the vents on the roof of the unit.
2. Use the FAJ5606B screws supplied with the assemblies to fasten the base section of the vent cap assembly.
3. Remove the three self-tapping screws in the top cover, located approximately 7 inches behind each vent cap. Attach one of the air deflectors in this location for each vent cap, using the screws removed.

## III. DUCT CONNECTIONS

Before attaching the ducting to the unit, remove the sheet metal panel that is used to protect the outlet and return openings. The ductwork may be screwed or bolted to the unit flange with suitable gaskets to insure a weathertight seal. Be sure the sheet metal overlaps the flange on the unit.

**CAUTION:** Take care not to puncture the evaporator coil when drilling the duct flange.

All duct work external of the structure must be properly insulated and water-proofed.

All openings in the structure must be properly flashed and vibration isolated in accordance with local codes and good building practices. Supply and return duct work should be provided with an approved vibration eliminator. The vibration eliminator must be located within the structure.

## IV. GAS CONNECTIONS

The gas supply pipe for the Model 479 should be a direct line from the gas meter or propane supply tank. The gas supply pipe should terminate at the unit with a tee.

The size of the gas pipe used depends upon the length of run and allowable pressure loss established by the utility. Never use pipe smaller than the gas connection to the unit manifold.

The following are pertinent recommendations:

1. Avoid low spots in long runs of pipe. It is best to grade all pipe 1/4 inch in every 15 feet to prevent traps. All horizontal runs should grade up to risers.
2. A drip leg must be provided at any point in the line of pipe where condensate may collect. Such drip leg or drip legs shall be installed in locations readily accessible to permit cleaning or emptying. The drip legs should not be located where they are subject to freezing. See Figure 4. Check local codes for size and capacity of drip legs.
3. Three manual shutoff valves should be installed; one valve between the gas supply pipe and heating section, and one between each chiller and the gas supply pipe.
4. A ground joint union should be installed between the individual gas controls manifold and each manual shutoff valve.

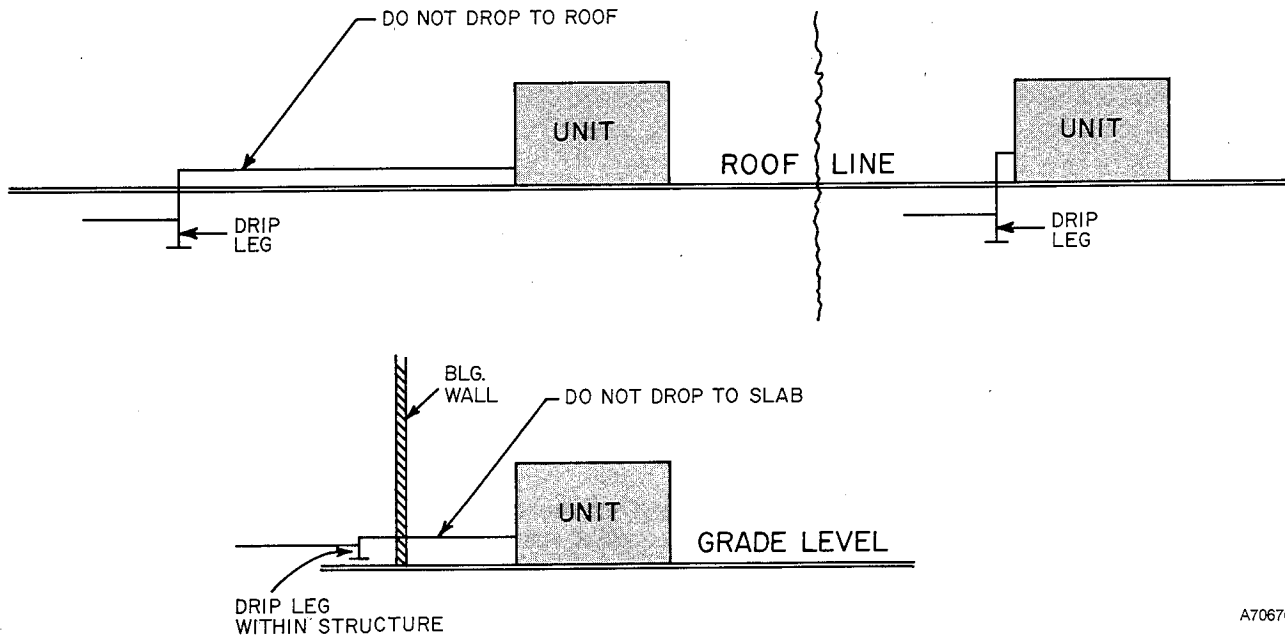

A70676

Figure 4—Drip Leg Location

5. The joint compound (pipe dope) used must be resistant to the action of propane gas.
  6. Support all piping with appropriate hangers. Use a minimum of one hanger every ten feet.
  7. After all gas connections are made, check for leakage using soap and water solution, or leak-check unit in accordance with local utility regulations.
- WARNING: NEVER USE A MATCH OR OPEN FLAME FOR LEAK TESTING.**

### Purging Gas Lines

After making all gas connections and checking for leaks, it is now necessary to purge the supply lines to eliminate trapped air.

**WARNING: NEVER PURGE GAS LINES INTO THE COMBUSTION CHAMBERS OF THE FURNACE OR CHILLERS.**

1. With the furnace manual gas valve and pilot shutoff valve closed, disconnect the pilot supply tube at the pilot shutoff valve on the furnace.
2. Open the manual shutoff valve; then open the pilot shutoff valve and allow the supply line to purge until the odor of gas is detected. Immediately upon detecting a gas odor, turn off the gas and reconnect the pilot supply tube. Allow at least five minutes to elapse before lighting pilot.
3. Purge the gas line to each chiller in the same manner as described for the furnace.

### V. ELECTRICAL CONNECTIONS

The Model 479 requires a 3 wire, 230 volt, 60 cycle, 3 phase power supply. Check the unit rating plate to make sure the power supply meets all the electrical

specifications. Electrical connections must be made in accordance with the National Electrical Code and the electrical code of the local area.

The field high voltage connections are made to the disconnect box located between the two chillers at the right end of the unit.

The field low voltage wiring consists of running seven wires from the thermostat subbase to the low voltage terminal block in the furnace. See Figure 5 for low voltage field wiring.

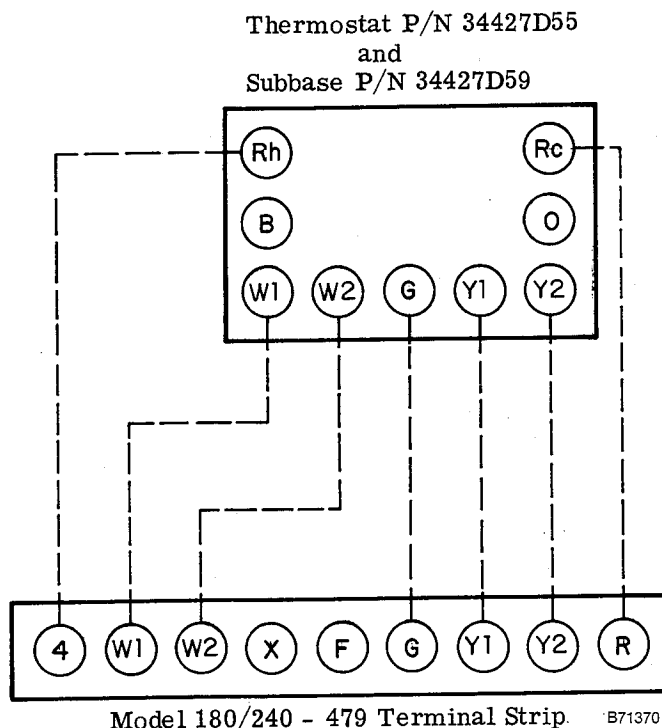

Figure 5—Low Voltage Field Wiring

## VI. CHILLED WATER SYSTEM

The cooling section of Model 180-479 is comprised of two 90,000 BTUH chillers and a 180,000 BTUH cooling coil which is divided into two separate 90,000 BTUH sections (top and bottom). The bottom section of the chilled water coil is supplied chilled water by one chiller (1st stage cooling) while the top section of the chilled water coil is supplied chilled water by the other chiller (2nd stage cooling). The chilled water circuit of each chiller is independent of the other; therefore, each chiller must be charged with water before the cooling section can be operated.

The design of Model 240-479 is basically the same as that of Model 180-479 except the 240-479 utilizes two 120,000 BTUH chillers and a 240,000 BTUH cooling coil which is divided into two separate 120,000 BTUH sections. Each chiller of the Model 240-479 must also be charged with water since the chilled water circuit of each chiller is independent of the other.

**CAUTION:** The water seals will be damaged if the pumps are operated without water in the system.

Freezing conditions will not damage the pumps; however, do not operate the pumps when the chillers or chilled water lines are frozen.

### Charging the System with Water

Charge the chilled water system with water as follows:

1. Turn off manual gas valves to both chillers and turn off electrical power at disconnect switch.
2. Remove access panel from both of the chillers at the chiller tank end. Remove chilled water tank lids.
3. Fill both chiller tanks with water having less than 100 ppm chlorides until distributor pans are covered, or add 12.2 gallons to each chiller of Model 180-479 or 13.6 gallons to each chiller of Model 240-479.

**NOTE:** If the local tap water has more than 100 ppm chlorides, charge the chilled water system with distilled or deionized water. Check the local water company and/or county agricultural agent for analysis of tap water being used in your area.

**CAUTION:** Never use home soft water, water softening additives, water cleaning compounds, coloring additives, acidizing materials, stop leak additives, or other commercial water additives in the chilled water system.

**WARNING:** To prevent personal injury, disconnect condenser fan motor lead in the control box of each chiller at this time.

4. Replace both chiller tank lids, then start water pumps.

If water of either chiller does not circulate when the pumps are started, air may be trapped in the system. Most chillers are equipped with a Gorman-Rupp water pump (plastic). On these chillers, it is necessary to disconnect the chilled water line at the chiller tank

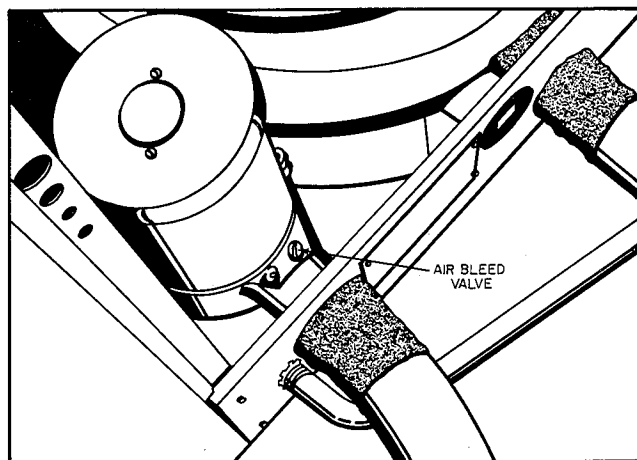

A69408

Figure 6—Air Bleed on Water Pump

to bleed the air. Operate water pumps until water appears at the disconnected water line, then reconnect water line to chiller tank.

If the chiller with the trapped air is equipped with a Wayne water pump (metal), it is not necessary to disconnect the water line to bleed the trapped air. Bleed the air from the pump through the 1/4-inch slotted head valve located on top of the pump discharge. See Figure 6. Open valve with a screwdriver. Close valve when a steady stream of water appears.

5. Leak test the chilled water system.
6. Remove operating level drain plug (located on side of tank) from both chilled water tanks and continue to operate pumps until water stops flowing from drain openings.

**NOTE:** With the pumps running, the water level is correct for each chiller when water stops flowing from its drain opening.

7. Replace operating level drain plugs, then turn off pumps.
8. Refer to "Freezing Weather Protection" on page 6. If freeze protection is required, decide on which type of antifreeze to use.

The procedure for adding Ucar-17 is given in Step 9. The procedure for adding methanol antifreeze is given in Step 10. If antifreeze is not required, disregard Steps 9 and 10.

9. Adding Ucar-17 Antifreeze - Refer to Table III. Drain out amount of water from *each* chiller tank, equal to amount of antifreeze to be added. Add required amount of Ucar-17 to each chiller tank. Recheck operating water level and correct. Do *not* use any chilled water additive when using Ucar-17 in the recommended concentration. Omit Steps 10 and 11.

10. Adding Methanol Antifreeze - Refer to Table III. Drain out amount of water from *each* chiller, equal to amount of antifreeze to be added. Add required amount of methanol antifreeze. Add the contents of the chilled water additive package as described in Step 11.

11. Remove chiller tank lids, and add contents of chilled water package (one package to each chilled water tank is sufficient).
12. Replace both chiller tank lids and reconnect condenser fan motor leads in the chiller control boxes.
13. Turn on water pumps. Pumps should operate a minimum of 10 minutes to dissolve all chilled water additive when chilled water additive is used.
14. Replace access panels and turn on manual gas valves to both chillers. Cooling section is now ready to operate.

### Corrosion Protection

The metallic components of the chilled water system must be protected from corrosion by the addition of an inhibitor to the chilled water circuit of each chiller. Two packages of chilled water additive are furnished with the unit. The contents of one package of Chilled Water Additive P/N 62875D1 must be added to the chilled water circuit of each chiller when water only or when water and methanol antifreeze are used in the chilled water system.

Do *not* add any chilled water additive to the system when Ucar-17 is used for freeze protection. Ucar-17 contains sufficient inhibitor when used in the recommended concentrations as shown in Table III.

### Freezing Weather Protection

Freeze protection is only required when the chilled water coil is subjected to freezing temperatures or when the unit is to operate under freezing conditions.

The cooling section is equipped with galvanized chillers. Ucar-17 is the only permanent (glycol-base) antifreeze approved for use in the chilled water system. When Ucar-17 is used for freeze protection, the minimum concentration must be 33% by volume.

Table III gives the types of antifreeze, percent of antifreeze concentration, and amount of antifreeze to use in each chiller of the 180 and 240-479 at various outdoor temperatures.

## VII. START-UP AND ADJUSTMENTS

Important: Before starting the heating or cooling section, make certain all electrical connections have been made and the gas piping has been connected, purged and leak tested.

**CAUTION:** Recheck all factory and field connections, making sure they are tight.

### Pilot Adjustment

Remove necessary access panels from furnace and chillers.

Light pilots according to instructions on furnace and chillers.

For Natural Gas. Flame should be of sufficient length to provide good impingement on the monometal of the Bryant pilot. The flame should extend upward between the carryover ports of the two adjacent burners.

For Propane Gas. Flame should surround tip of the thermocouple element of the pilot and extend downward to include 3/8" to 1/2" of the thermocouple. The flame must not come in contact with any other part of the thermocouple or its lead wire. The flame lies under the carryover ports of the burners and merges with the carryover flames.

The pilot flame can be adjusted if it does not have the appearance described above. The pilot adjusting screw for natural and propane units (chillers and furnace) is located under a screw cap in the handle of the manual pilot shut off valve. Adjust as follows:

1. Remove the screw cap to expose the adjusting screw, then turn pilot flame to full on position.
2. Turn the adjusting screw until the flame has the desired appearance.

**TABLE III  
APPROVED ANTIFREEZE TYPES**

Lowest Outdoor Temperature (°F)	Percent of Concentration		Amount Required (Gallons)			
	*Methanol	**Ucar-17	180-479 (Each Chiller)		240-479 (Each Chiller)	
			Methanol	Ucar-17	Methanol	Ucar-17
20	20	33	2-1/2	4-1/4	2-3/4	4-1/2
15	20	33	2-1/2	4-1/4	2-3/4	4-1/2
10	22	33	2-3/4	4-1/4	3-1/4	4-1/2
5	26	33	3-1/4	4-1/4	3-3/4	4-1/2
0	29	33	3-3/4	4-1/4	4	4-1/2
-5	32	36	4	4-1/2	4-1/2	5
-10	34	39	4-1/4	4-3/4	4-3/4	5-1/4
-15	36	42	4-1/2	5-1/4	5	5-3/4
-20	38	45	4-3/4	5-1/2	5-1/4	6-1/4
-25	43	47	5-1/4	5-3/4	6	6-1/2
-30	44	49	5-1/2	6	6	6-3/4

\*Chilled water Additive (Borax and Chromate) P/N 62875D1 must also be used. Refer to "Corrosion Protection" on page 6.

\*\*No chilled water additive required. Refer to "Corrosion Protection" on page 6.

### Adjusting Gas Input

Gas input of the furnace and each chiller must be checked and adjusted if necessary to agree with that shown on the rating plates. The burners are equipped with fixed orifices.

**CAUTION:** The chillers may be run for short periods with the panels removed. Prolonged operation with panels removed should be avoided.

Natural gas units are equipped with adjustable gas pressure regulators. Propane gas units are not equipped with a pressure regulator.

One of the following two methods may be used to check natural gas input on both the furnace and chillers.

#### A. Measuring Gas Flow at Meter

All gas appliances must be turned off except the burners on the manifold being checked when measuring the gas flow at the meter to adjust the gas input. Proceed as follows:

1. Determine the number of seconds required for the gas meter test dial to complete one revolution.
2. Divide 3600 by the number of seconds in Step 1.
3. Multiply the result in Step 2 by the number of cubic feet of gas flow per hour.
4. Multiply the result of Step 3 by the Btu heating value of the gas (consult local utility for value). This is the total measured Btu/hr input.

Compare this value with the one shown on the rating plate.

Example: Suppose the size of the test dial is 5 cu. ft.; it takes 40 seconds for the dial to complete one revolution; heating value of the gas is 1050 Btu/cu. ft. Proceed as follows:

40 seconds to complete one revolution  
3600 divided 40 equals 90  
90 x 5 = 450 cu. ft. per hour of gas flow  
450 x 1050 = 472,5000 Btuh input

Only minor changes should have to be made at the pressure regulator to bring it within the rated input of the unit. If the manifold pressure must be changed more than 0.3" w.c. to obtain the rated input, the orifices should be changed accordingly.

#### B. Using Water Manometer

Proceed as follows when using a water manometer to measure the manifold pressure when adjusting the gas input:

1. Connect a water manometer to the 1/8" pressure tap on the manifold or gas valve.
2. With the burners fired, set the correct manifold pressure as shown in Table IV. Check with the gas utility for the Btu valve and specific gravity of gas in the area.

**TABLE IV—MANIFOLD PRESSURE  
(Inches w.c.)**

BTU Value	Specific Gravity				
	0.59	0.61	0.63	0.65	0.67
900	3.9"	4.0"	4.1"	4.2"	4.3"
950	3.5"	3.6"	3.7"	3.8"	3.9"
1000	3.1"	3.2"	3.3"	3.4"	3.5"
1025	3.0"	3.1"	3.2"	3.3"	3.4"
1050	2.8"	2.9"	3.0"	3.1"	3.2"
1100	2.6"	2.7"	2.8"	2.9"	3.0"

### Adjusting Pressure Regulator

If the measured and rated input are not approximately the same, the gas pressure regulator may be adjusted as follows:

To increase input. Remove regulator sealing cap and turn gas pressure regulator adjusting screw clockwise.

To decrease input. Remove regulator sealing cap and turn gas pressure adjusting screw counterclockwise.

### Checking Propane Gas Input

The burner orifices are sized for rated input with a manifold pressure of 11.0" w.c. for propane gas. Connect a manometer of the 1/8" pressure tap on the chiller manifold gas valve. With the burners fired, adjust regulator at the supply tank to provide a pressure of 11.0" w.c. Check manifold pressure of each chiller.

Check the furnace manifold pressure to see that it is also 11.0 inches w.c.

### Burner Adjustment

To adjust the primary air to each burner, partially close the air shutter until there is a slight yellow tip at the top of each flame, then open the air shutter until the yellow tip just disappears. This should be done after the burners have been operating at full input for 5 minutes.

## VIII. FURNACE OPERATION

In order to check the furnace for proper performance, the following sequence of control operation is given.

**CAUTION:** The pilot valve and main burner manual valve must be closed for at least five minutes before starting the furnace.

1. Set the thermostat system switch to "heat", set the fan switch to "auto" and set the thermostat below room temperature.
2. Turn on electrical power to the unit.
3. Open pilot gas valve. Gas will flow to the pressure switch and to the pilot. The electrical contacts in the pressure switch close, energizing the reignition coil which ignites the pilot gas. (Natural gas only; pilots on propane unit must be lighted manually per instruction on rating plate.)

The pilot flame causes the monometal contacts in the Bryant 733 pilot to "Break" the re-ignition coil circuit

and "make" the circuit to, but not through, the first stage gas valve. On propane units, with thermocouple energized, the pilot relay switch action makes the circuit to gas valve.

4. Set the thermostat above room temperature. This completes the circuit and energizes the gas valve.
5. Gas flows through the gas valve to the burners via bypass where it ignites. If the conditioned space temperature continues to drop, the second stage of the thermostat closes and opens the second gas valve bringing the unit to full input.

With the furnace operating, make the following checks:

The automatic pilot should turn the main gas off if the pilot flame goes out.

Check this while the furnace is operating by shutting off the pilot gas. The main burners should shutdown.

Allow the furnace to cool and the blowers to stop, then check the upper limit switch.

### Limit Control

The furnace is equipped with a lower and upper limit control. When the lower limit opens, the first stage gas valve is de-energized, shutting off the gas. The upper limit control has a dual function; its primary action is to shut off the first stage gas valve if the unit overheats; as the gas valve is shut off, the fan delay relay is energized, starting the blower. The upper limit is a single pole double throw switch.

The recommended method for checking the limit controls is to gradually block off the return air after the furnace has been operating for a period of at least five minutes. As soon as the limit has proven safe, the return air openings should be unblocked to allow normal air circulation through the unit. Whether or not the limit is functioning properly, and will "fail-safe" in case of motor failure or overheating of the unit can be determined using this method.

### Fan Relay

The unit is equipped with a fan delay relay switch located in the control box. When the observer faces the control, the adjustment lever is moved upward to lengthen the off cycle. When the off cycle is lengthened, the on cycle is shortened automatically. Reverse the process to shorten the off cycle.

### Airflow and Temperature Rise

The temperature rise is the difference between the temperature of the air in the return duct and that in the discharge duct near the furnace. This temperature rise, measured after equilibrium has been attained (approximately five minutes), should be within the range of 45°F to 75°F for Model 180-479 and 20°F to 50°F for Model 240-479.

An adjustable sheave on the blower motor pulley is used to adjust the blower speed as follows:

**CAUTION:** Turn off electric power to unit before removing or replacing blower belt. Proceed as follows:

1. Loosen the motor from the base and slide the motor toward the blower housing. Remove the belt from the blower.

2. Loosen the set screw in the movable flange of the sheave. Screw the movable flange toward the fixed flange to increase the blower speed, away from the fixed flange to reduce the blower speed. Tighten the set screw on one of the two flat surfaces on the pulley hub.

**Important:** Increasing the blower speed will impose a greater load on the blower motor. Do not exceed the rated current draw of the motor.

3. Replace the belt and adjust for proper tension. The belt should have approximately 1" sag under normal finger pressure.

4. Check motor pulley and blower pulley for proper alignment.

## IX. COOLING OPERATION

Perform the following steps to check the cooling section for proper operation.

**WARNING:** The main manual gas valve for both chillers must be closed for at least 5 minutes before operating the cooling sections.

1. Be sure the manual gas valves for both chillers are in the OFF position. Light pilots as described on Instruction Plate.

2. With the thermostat subbase switch levers on COOL and AUTO, turn on both manual gas valves. Set thermostat at its lowest setting. Make certain both chillers are operating. To check for correct operation of the electrical circuit; observe operation of gas valve and solution pump of each chiller, all condenser fan motors and the blower. Increase the setting of the thermostat gradually until one chiller shuts off. Set thermostat above room temperature and observe that the other chiller shuts off.

3. Set thermostat subbase fan switch to ON and check blower operation. The blower should run continually with the thermostat set above or below room temperature.

4. To place the system in operation, replace all panels and set thermostat at the desired temperature.

## SEQUENCE OF OPERATION

### (Cooling Section)

Both the 180-479 and 240-479 are equipped with two stage cooling. Chiller No. 1 operates on the initial call for cooling (single stage cooling). When additional cooling is required, Chiller No. 2 is also activated (two-stage cooling).

Refer in Figures 7 and 8. When the thermostat system switch is in the COOL position and the fan switch is in the AUTO position, the first stage cooling bulb in the thermostat will close the circuit between terminals Y1 and R, and between terminals Y1 and G when the thermostat calls for cooling.

Closing the circuit between terminals Y1 and G energizes the blower relay (2A1) and closes its nor-



mally open contacts. This causes current to flow through the contactor (2M) winding and energizes the contactor. The energized contactor starts the blower motor (3E).

Closing the circuit between terminals Y1 and R completes the control circuit for Chiller No. 1 and turns this chiller on for single stage cooling. Chiller No. 2 is inactive and will not operate until the temperature in the conditioned space rises and calls for additional cooling.

If the cooling load of the conditioned space is too large for Chiller No. 1 to provide sufficient cooling, the thermostat's second stage cooling bulb will close the circuit between Y2 and R.

Closing the circuit between Y2 and R, places the control relay (2A2) across the secondary of Chiller No. 1 transformer (1A1). The energized control relay (2A2) completes the control circuit of Chiller No. 2 and turns this chiller on (two stage operation).

When the thermostat is satisfied, the thermostat's second bulb will break the circuit between terminals R and Y2. This action de-energizes the control relay (2A2) which opens the control circuit of Chiller No. 2 and turns off Chiller No. 2. Chiller No. 2 will remain idle until additional cooling is required.

### **HIGH TEMPERATURE CUTOFF (Model 180-479)**

Refer to Figure 7. Each chiller of Model 180-479 is equipped with a high temperature limit switch (7H1 on Chiller No. 1 and 7H3 on Chiller No. 2) located on the front of the generator, plus a circuit breaker (2J1 on Chiller No. 1 and 2J2 on Chiller No. 2). The circuit breaker for each chiller is located in the chiller control box.

If the generator of either chiller becomes overheated, its associated limit switch (7H1 or 7H3) will open, providing a current path through heater element of the circuit breaker (2J1 or 2J2) of the respective chiller. The current flow through the heater element of the circuit breaker will cause its normally closed contacts to open and break the 24-volt circuit to the magnetic gas valve (5B1 or 5B2). The de-energized gas valve will turn off the gas supply to the burners of the overheated generator. The remaining normally operating chiller will continue to operate.

The circuit breaker must be reset manually by pushing the red reset button that protrudes through the rear of the chiller control box.

A secondary high temperature limit switch (7H2 on Chiller No. 1 and 7H4 on Chiller No. 2) is connected in series with the gas valve (5B1 on Chiller No. 1 and 5B2 on Chiller No. 2) to insure closing of the gas valve in the event of a high temperature failure and the limit switch (7H1 on Chiller No. 1 and 7H3 on Chiller No. 2) does not open.

The secondary limit switch is located on the generator header and must be reset manually.

### **HIGH TEMPERATURE CUTOFF (Model 240-479)**

Refer to Figure 8. Each chiller of the 240-479 is equipped with two high temperature limit switches (7H1 & 7H2 on Chiller No. 1, and 7H5 & 7H6 on Chiller No. 2). A high temperature limit switch is located on the front of each generator of each chiller.

If either generator of Chiller No. 1 becomes overheated, the associated high temperature limit switch (7H1 or 7H2) will open, causing the circuit breaker (2J1) to go into lockout position. The open contacts of the circuit breaker de-energizes the gas valve and shuts off the gas supply to the burners of both Chiller No. 1 generators.

The circuit breaker (2J1) for Chiller No. 1 is located in the Chiller No. 1 control box and must be reset manually.

Two secondary high temperature limit switches (7H3 and 7H4-one on each generator header of Chiller No. 1) are connected in series with the Chiller No. 1 gas valve (5B1). If a generator overheats and its associated high temperature limit switch (7H1 or 7H2) does not open, the secondary high temperature limit switch (7H3 or 7H4) on the header of this generator will open and break the circuit to the gas valve, de-energizing the gas valve and shutting off the gas supply to the burners of both Chiller No. 1 generators.

The high temperature cutoff circuit of Chiller No. 2 functions the same as the high temperature cutoff circuit of Chiller No. 1. The high temperature cutoff circuit of Chiller No. 2 is comprised of high temperature limit switches 7H5 and 7H6, circuit breaker 2J2, secondary high temperature limit switches 7H7 and 7H8.

If a high temperature failure should occur and disable Chiller No. 1, Chiller No. 2 will continue to operate and provide single stage cooling; likewise, Chiller No. 1 will provide single stage cooling if a high temperature failure should disable Chiller No. 2.

### **AMBISTAT PART LOAD CONTROL (Models 180-479 and 240-479)**

Refer to Figures 7 and 8. Each chiller is equipped with an ambistat part load control (7L1 on Chiller No. 1 and 7L2 on Chiller No. 2). The circuit consists of a temperature sensitive switch (located in the chiller control box) and a capillary tube. One end of the capillary tube is connected to the switch and the other end is inserted in the chilled water supply line. The switch contacts open when the chilled water temperature drops below 40°F. and breaks the circuit to the gas valve, shutting off the gas supply to the burners.

The chiller power relay remains energized and the condenser fan motors, solution pump and water pump will continue to run.

The ambistat switch contacts will close again when the chilled water supply temperature rises to 42°F. The energized gas valve turns the gas on again.

## Lubrication

Some blower motors are equipped with permanent lubricated bearings and require no further lubrication.

Blower motors that require lubrication are equipped with oil cups. Oil motor bearings with SAE 10-20 non-detergent oil each heating and cooling season.

**NOTE: BLOWER BEARINGS ARE OF THE PERMANENT LUBRICATED TYPE AND DO NOT REQUIRE ANY FURTHER OILING.**

## X. MAINTENANCE

Cleaning the Heating Unit.

1. Be sure that the main line disconnect switch is in the OFF position.

**TAG SWITCH WITH A SUITABLE WARNING LABEL.**

2. Remove the front access panel.
3. Turn off the manual gas valve and the pilot valve.
4. Disconnect the pilot and escapement tubing.
5. Remove the burners.
6. Remove the flue baffle retainer and the flue baffles.
7. Clean the flue passages with a suitable brush.
8. Reassemble the furnace by reversing the above procedure, making sure all seals are reinstalled properly.
9. Check belt conditions and proper tension of belt (approximately 1/2 inch deflection).
10. Filters in the 180-479 are of the disposable type and should be inspected periodically and replaced when dirty with filters of the same type and size. Filters in the 240-479 are permanent type filters and should be cleaned periodically. Make sure the arrows on the edge of the filter point in the direction of the airflow.

## Cleaning the Condenser Coil

The condenser coil fin surfaces should be inspected from time to time and cleaned as necessary. Cleaning may be accomplished by washing the fins with low pressure water from a garden hose. Detergent may be used, prior to rinsing, when oil or grease has coated the fin surfaces. Care must be taken to be sure that the soft aluminum fins are not bent.

**WARNING:** Disconnect the electric power before cleaning the cooling coil.

## Summer Chiller Operation

It may be necessary to drain, flush and refill the chilled water system of each chiller with tap water if antifreeze was used for winter protection. A high antifreeze concentration will result in a reduction of the cooling capacity of the unit.

Be sure to add one package of Chilled Water Additive P/N 62875D1 to the chiller tank of each chiller of Model 180-479 or the Model 240-479 when water only is used in the chilled water system for summer operation.

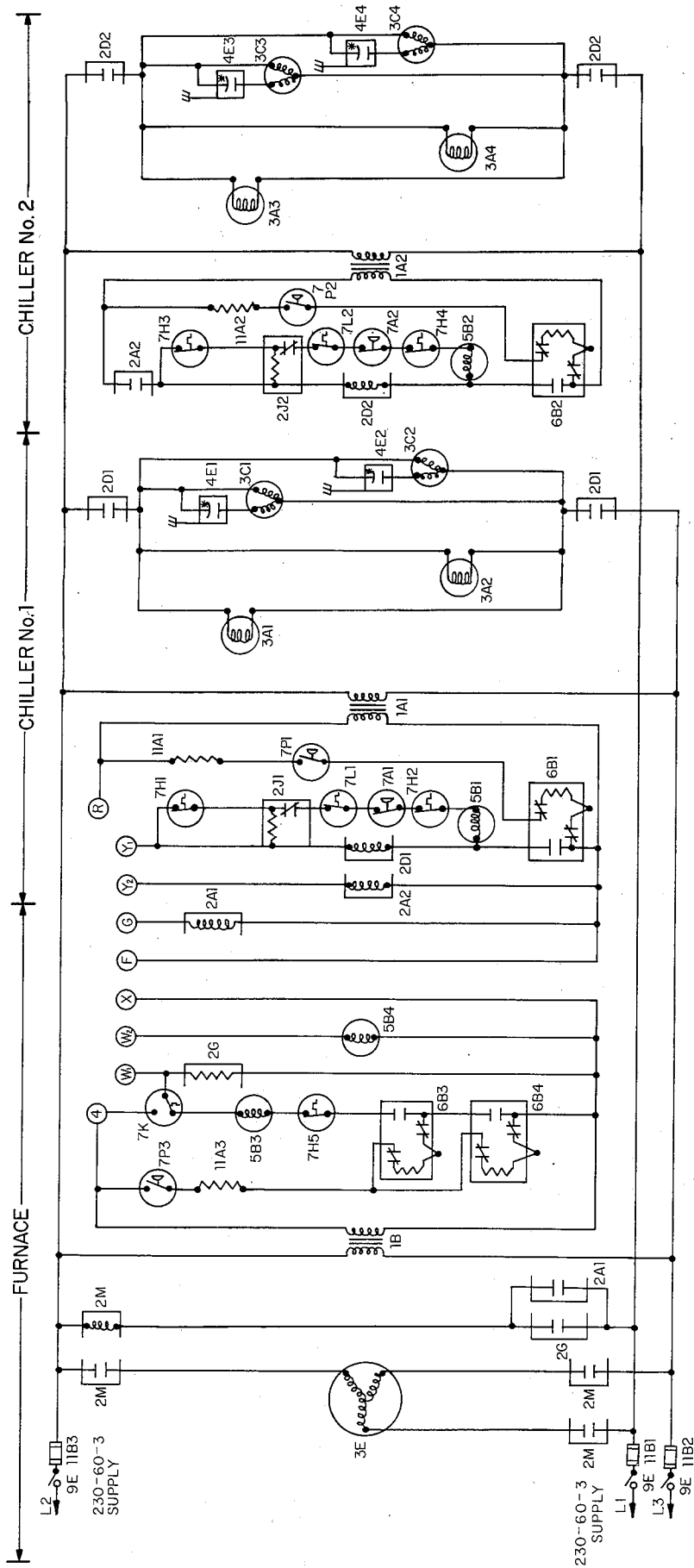

A70215

### LEGEND

- 1A1 & 1A2-Transformer (Cooling)
- 1B-Transformer (Heating)
- 2A1-Blower Relay, SPST, (Cooling)
- 2A2-Control Relay, SPST
- 2D1 & 2D2-Power Relay, DPST, (Cooling)
- 2G-Heating Relay
- 2J1 & 2J2-Relay Circuit Breaker Lockout
- 2M-Blower Contactor, TPST
- 3A1 & 3A3-Solution Pump Motor
- 3A2 & 3A4-Water Pump Motor
- 3C1 Thru 3C4-Fan Motor, PSC
- 3E-Blower Motor
- 5B1 & 5B2-Gas Valve (Cooling)
- 5B3-Gas Valve (1st Stage) (Heating)
- 5B4-Gas Valve (2nd Stage) (Heating)
- 6B1 Thru 6B4-Reignition Pilot
- 7A1 & 7A2-Pressure Switch, SPST
- 7H1, 3, & 5-Limit Switch (High Temp Cont.)
- 7H2, & 4-Limit Switch (Sec. High Temp. Manual Reset), SPST
- 7K-Limit Switch, Upper, SPDT
- 7L1 & 7L2-Ambistat (Part Load Control), SPST
- 7P1 Thru 7P3-Pressure Switch, Pilot Gas, SPST
- 9E-Disconnect Switch
- 11A1 Thru 11A3-Resistor
- 11B1 & 11B2-30 Amp. Fuse
- 11B3-50 Amp Fuse
- 4E1 Thru 4E4-Capacitor

Figure 7—Model 180-479 Wiring Diagram

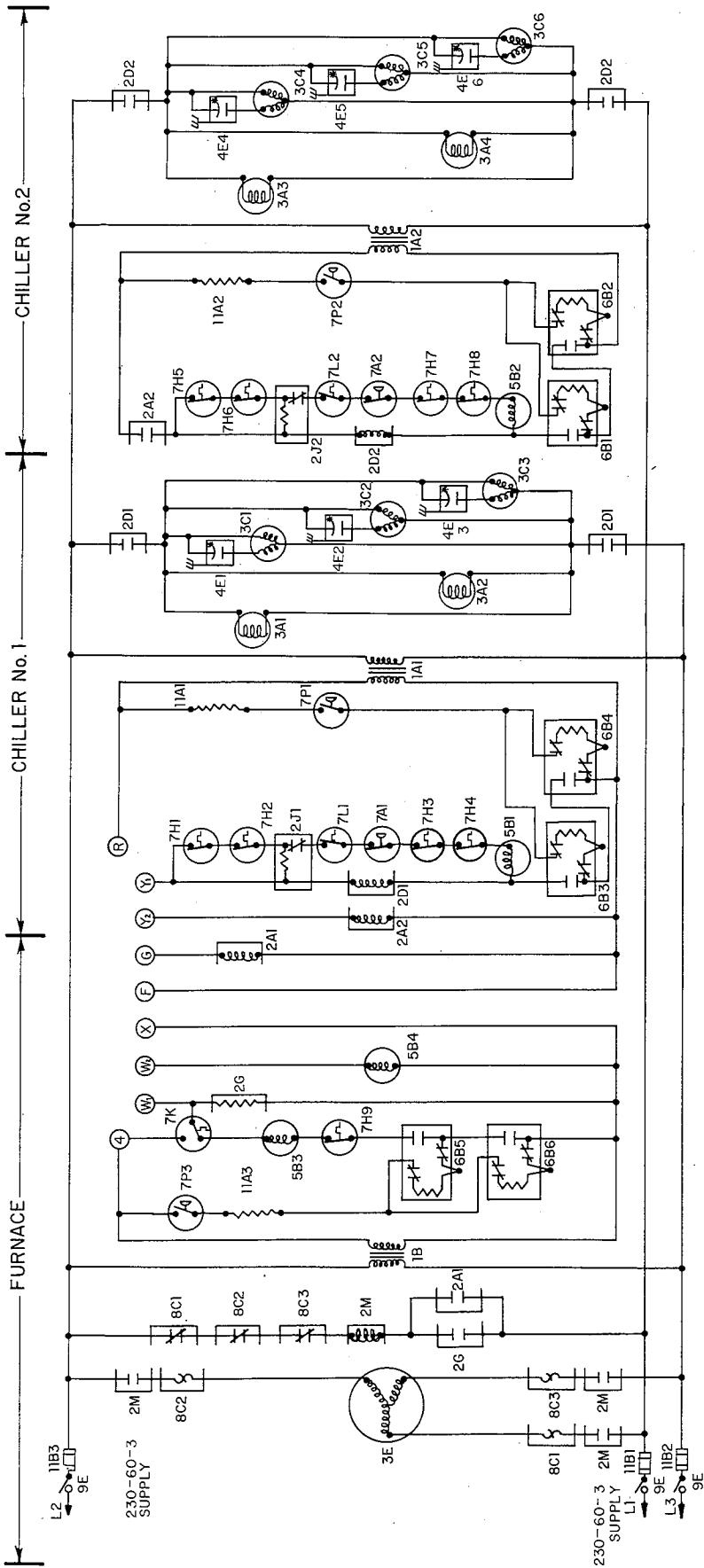

A70216

**LEGEND**

- 1A1 & 1A2-Transformer (Cooling)
- 1B-Transformer (Heating)
- 2A1-Blower Relay, SPST, (Cooling)
- 2A2-Control Relay, SPST
- 2D1 & 2D2-Power Relay, DPST, (Cooling)
- 2G-Heating Relay
- 2J1 & 2J2-Relay Circuit Breaker Lockout
- 2M-Starter, Blower TPST
- 3A1 & 3A3-Solution Pump Motor
- 3A2 & 3A4-Water Pump Motor
- 3C1 Thru 3C6-Fan Motor, PSC
- 3E-Blower Motor
- 5B1 & 5B2-Gas Valve (Cooling)
- 5B3-Gas Valve (1st Stage) (Heating)
- 5B4-Gas Valve (2nd Stage) (Heating)
- 6B1 Thru 6B6-Reignition Pilot
- 7A1 & 7A2-Pressure Switch, SPST
- 7H1, 2, 5, 6, & 9-Limit Switch SPST (Temp Cont.)
- 7H3, 4, 7 & 8-Limit Switch (Sec. Temp Cont. Manual Reset), SPST
- 7K-Limit Switch, Upper, SPDT
- 7L1 & 7L2-Ambistat (Part Load Control), SPST
- 7P1 Thru 7P3-Pressure Switch, Pilot Gas, SPST
- 8C1 Thru 8C3-Starter Overload (Manual Reset)
- 9E-Disconnect Switch
- 11A1 Thru 11A3-Resistor
- 11B1 & 11B2-45 Amp. Fuse
- 11B3-70 Amp. Fuse
- 4E1 Thru 4E6-Capacitor

**Figure 8—Model 240-479 Wiring Diagram**

# Installation Instructions

479  
Sizes 180 & 240  
Series E

**bryant**

ATTACH TO INSTALLATION INSTRUCTIONS 39479D8

39479D12  
4/1/72

Use attached 39479D8 Installation Instructions (with changes indicated below) to install sizes 180 and 240 of Model 479, Series E, units.

Models 180- and 240-479 Series E units differ from Series D units as described below.

1. GAS INPUT to the cooling section of Model 180-479 was increased from 450,000 Btuh to 492,000 Btuh (246,000 Btuh input each chiller). The generator burner orifices were changed from #39 drill size to #36 drill size on the natural gas unit. The burner orifices on the propane unit were changed from #53 drill size to #52 drill size.
2. GAS INPUT to the cooling section of Model 240-479 was increased from 600,000 Btuh to 640,000 Btuh (320,000 Btuh input each chiller). The generator burner orifices were changed from #41 drill size to #39 drill size on the natural gas unit. The burner orifices on the propane unit were changed from #54 drill size to #53 drill size.
3. AUTOMATIC PILOT REIGNITION is used on both natural and propane units in both the heating and cooling sections on both Models 180- and 240-479. The wiring diagrams on pages 11 and 12 apply to both natural and propane gas units.
4. FUSE SIZE was changed on Model 180-479. The 180-479 now uses one 60 amp and two 30 amp fuses.

NOTE: Hydraulic Pump Heater Kit P/N 65134D01 (2 required) must be field installed on each chiller if the cooling section is to be operated at outdoor temperatures below 40°F. Adding the heater kits permits operation of the cooling section at outdoor temperatures down to -30°F. Antifreeze must also be added for protection at the lowest outdoor temperature.

**FILE  
COPY  
DO NOT  
REMOVE**

## Free Manuals Download Website

<http://myh66.com>

<http://usermanuals.us>

<http://www.somanuals.com>

<http://www.4manuals.cc>

<http://www.manual-lib.com>

<http://www.404manual.com>

<http://www.luxmanual.com>

<http://aubethermostatmanual.com>

Golf course search by state

<http://golfingnear.com>

Email search by domain

<http://emailbydomain.com>

Auto manuals search

<http://auto.somanuals.com>

TV manuals search

<http://tv.somanuals.com>