

**Special Edition Includes:**

**Dr. Ellington Darden's  
Six Week Fast Fat Loss –  
Body Leanness Program**

 **BOWFLEX**  
**REVOLUTION**



**The Bowflex Revolution®  
Owner's Manual  
and Fitness Guide**

POWERED BY  
 **SPIRAFLEX**

# Owner's Manual and Fitness Guide Table of Contents

Safety Precautions	1	Aerobic Rowing Position:	20
Safety Warning Labels	2	Breathing	20
Getting to Know Your Bowflex Revolution® Home Gym	4	Performing Your Routine	20
		Cool Down	20
Using Your Bowflex Revolution® Home Gym		The Workouts	21
SpiraFlex® Resistance	5	20 Minute Better Body Workout	21
Adjusting and Understanding the Resistance	5	Advanced General Conditioning	21
Attaching SpiraFlex® Resistance Plates	6	20 Minute Upper/Lower Body	22
Preparing for Use, Storing, and Moving	7	Body Building	23
Maintenance	8	Circuit Training – Anaerobic/Cardiovascular	24
Adjusting Cable Tension	9	True Aerobic Circuit Training	25
Cable Hookup for Leg Exercises	10	Strength Training	26
Cable Hookup for Leg Press Exercises	11		
Storing Leg Press Cables	12	Exercises	28
Storing Leg Extension Cables	13	Chest Exercises	29
		Shoulder Exercises	39
Attaching Hand Grips and Foot Harnesses	14	Back Exercises	50
Attaching Accessories, Benches and Seats	15	Arm Exercises	58
Leg Press Seatback	15	Abdominal Exercises	69
Leg Press Plate	15	Leg Exercises	73
Preacher Curl	16		
Multi-Position Bench	16	Muscle Chart	83
Companion Equipment	17	Exercise Log	85
Defining Goals	18	Bowflex® Body Leanness Program	87
Reaching Your Goals	19		
Designing Your Own Program	19	Warranty Information	106
Exercising Properly	20	Contact Information	109
Working Out	20		
Warming Up	20		

## Product Specifications

Dimensions (arms raised)	112" L x 37.8" W x 73" H (284cm x 98cm x 185.4cm)
Workout Area	84" x 64" (213.4cm x 162.6cm)
Assembled Unit Weight	336.2 lbs. (152.5 kg)
Shipping Weight	414.64 lbs. (188.1 kg)
SpiraFlex® Resistance	220 lbs. (100 kg)
SpiraFlex® Upgradability	300 lbs. (136 kg)
Maximum User Weight	300 lbs. (136 kg)

# Safety Precautions

## IMPORTANT SAFETY INSTRUCTIONS

The following definition applies to the word “**Warning**” found throughout this manual:



Indicates a potentially hazardous situation which, if not avoided, could result in death or serious injury.

## PRIOR TO USING THIS EQUIPMENT, OBSERVE THE FOLLOWING WARNINGS.



- Read and understand the Owner’s Manual prior to using this machine.
- This machine contains moving parts. Use Caution. Do not wear loose clothing or jewelry.
- Set up and operate this machine on a solid level surface.
- This machine is for Consumer use only.
- Do not use additional means to increase the resistance (lifting load) of this machine.
- Set up the machine so that there is a workout area of at least 7’ x 10’ (2.6 m x 2 m) of free space for safe operation of the Bowflex Revolution®. Keep third parties out of this area when the machine is in use.
- Operate the machine in the manner described in this manual. It can be hazardous to over-exert yourself during exercise.
- Make sure that all positional adjustment devices are securely engaged.
- Never move or adjust the seat while sitting on it. Never stand on the seat.
- Never attempt to exercise while the seat rail is in the folded position.
- Read and understand all Warning Labels on this machine.
- Keep children away from this machine and/or supervise them closely if they are near the machine or are present during its operation. This machine is not suitable as a children’s toy. There is a natural tendency for children to want to play on exercise equipment, and parents and others in charge of children should be aware of their respective responsibilities. Moving parts that may appear to present obvious hazards to adults may not appear to do so to children.
- Consult a physician prior to commencing an exercise program. If, at any time, you feel faint or dizzy, or experience pain, stop and consult your physician.
- Inspect this machine for loose parts or signs of wear. Pay special attention to Cables and Belts and their connections. Do not use if found in this condition; contact Nautilus Customer Service.
- This machine is designed for a User’s Weight Limit of 300 pounds (136 kg). Do not use if you are over this weight.

# Safety Warning Labels

The following safety warnings are located on the Bowflex Revolution® exercise machine. Please read all safety precautions and warning information prior to using your product. Be sure to replace any warning label if damaged, illegible, or missing. If you need replacement labels, please call a Bowflex Representative at 1-800-628-8458.

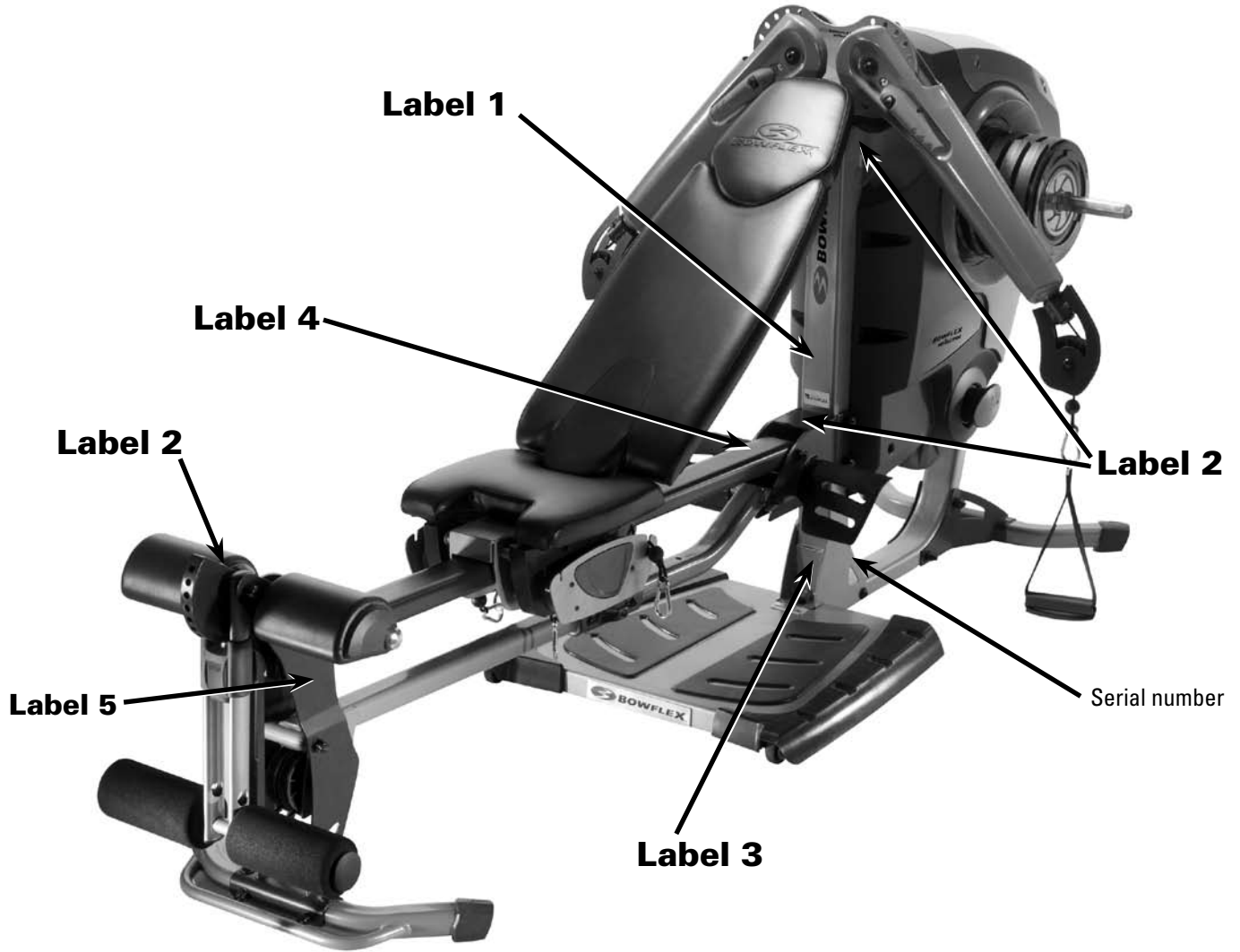

## Safety Warning Labels

The following safety warnings are located in site specific areas on the unit. Please review and understand the safety warning labels and their locations on the unit prior to use.

If you need to replace a warning label please call 1-800-628-8458 to obtain a new label.

**Label 1:** General use safety label.

**Location:** Front of the main unit above seat rail.

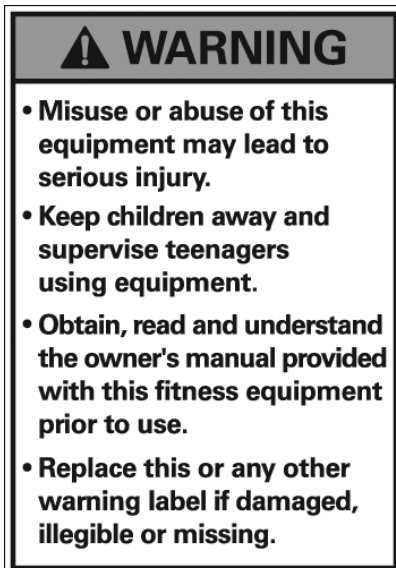

**Label 2:** Keep hands away.

**Location:** Below freearms on main unit; top of seat rail bracket; top of Leg Extension adjustment.



**Label 3:** Check all equipment before use.

**Location:** Bottom front of the main unit.



**Label 4:** Avoid crush hazard when folding the bench.

**Location:** Top of seat rail next to the main unit.



**Label 5:** Keep hands clear when folding.

**Location:** Both sides of the Leg Extension.



# Getting to Know Your Bowflex Revolution® Home Gym

Please take your time to read through the entire manual and follow it carefully before attempting to use your Bowflex Revolution® home gym. Also locate and read all warning labels that are posted on the machine. It's important to understand how to properly perform each exercise before you do so using SpiraFlex® Resistance.

The image below shows the machine set up in just one of many configurations. Included as standard accessories with your new Bowflex Revolution® home gym are a preacher curl attachment, leg press plate, leg press seatback, foot harnesses, and curl/pulldown bar. Instructions for attaching various accessories, storing cables, and changing out bench components are included later in this manual, as well as in the Assembly Manual.

## Bowflex Revolution® Parts Reference Guide

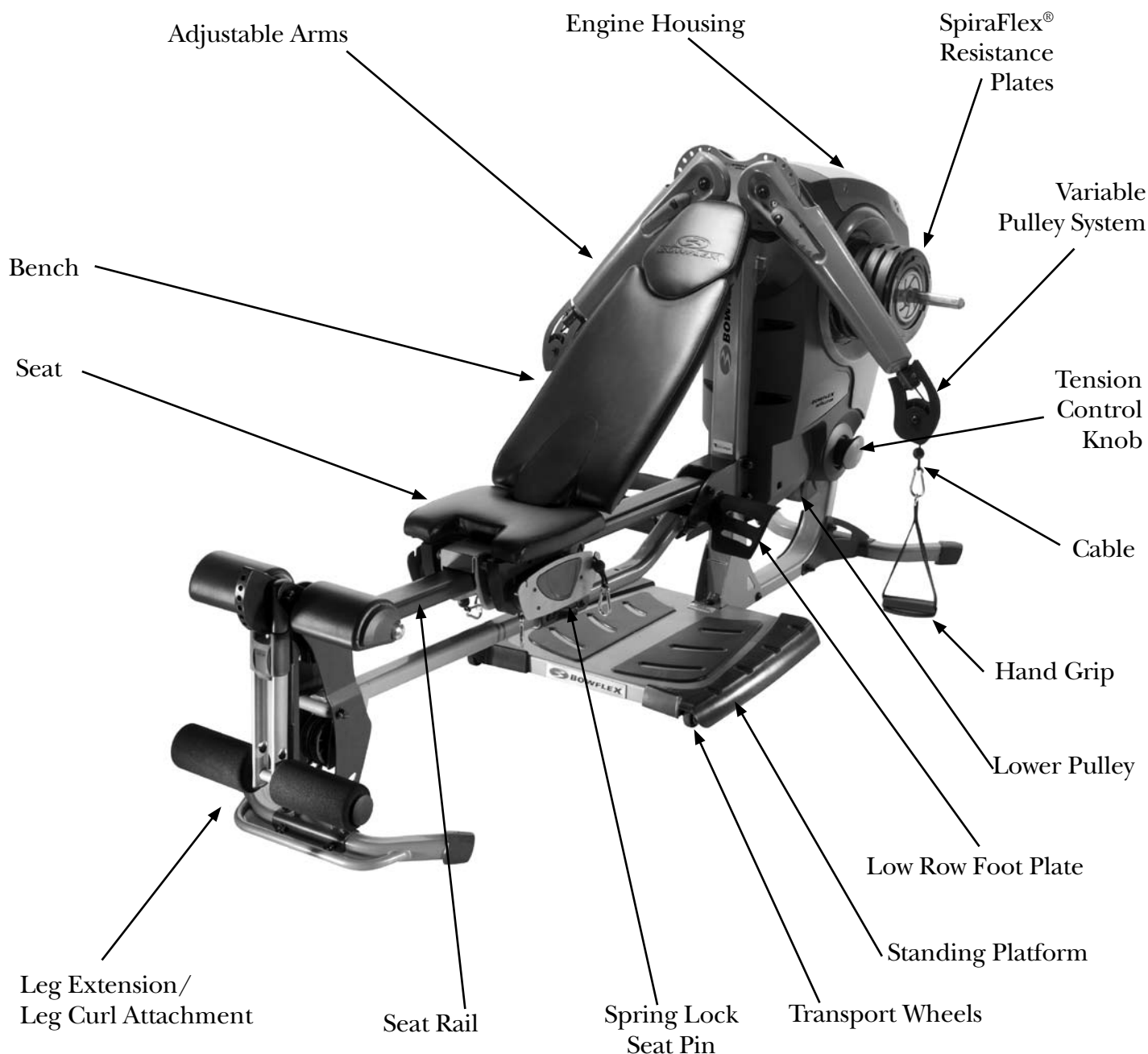

# Using Your Bowflex Revolution® Home Gym

## SpiraFlex® Resistance

The Bowflex Revolution® home gym features an ingenious patented technology called SpiraFlex®. The Bowflex Revolution® muscle-building resistance comes in the form of these cleverly designed resistance packs, each constructed with a heavy-duty elastic strap inside the pack. When you perform an exercise, these resistance packs rotate around the center, stretching the elastic strap and creating resistance.

A significant advantage of the resistance packs is that the resistance is present throughout the ENTIRE range of motion. That gives you a more consistent, gym-quality experience – which means your muscles get a bigger burn, a better workout and faster results.



SpiraFlex® technology is a non-inertial resistance mechanism that provides the smoothness and feel of gym-quality plate-loaded machines, but eliminates the excessive bulk and weight. This totally unique, state-of-the-art resistance system involves wrapping an elastic strap tighter and tighter around a coil, which is contained in a small canister that looks very similar to free weight plates, but weighs only a few pounds. Because no metal parts are used, SpiraFlex® technology is quiet, lightweight, portable, and safe.

**To upgrade to 300 pounds  
(136 kg) of resistance please  
call 1-800-663-6315**

## Adjusting and Understanding The Resistance

The Bowflex Revolution® home gym comes with 220 lbs. (100 kg) of resistance. The SpiraFlex® resistance plates look very much like free weight plates and are assigned a pound rating based on their resistance – including 5, 10, 20, and 40-pound packs (2.27kg, 4.54kg, 9.07kg, 18.14kg). The real power of the workout is in the RESISTANCE, not the weight. And that means you can quickly and easily stack these lightweight resistance plates onto the Revolution® – just like free weights – and get a great workout.

## Using Your Bowflex Revolution® Home Gym

### Attaching SpiraFlex® Resistance Packs

During assembly, you attached 5-lb (2.27kg) SpiraFlex® resistance packs to the machine. The 5-lb packs are permanently attached to the machine. The Bowflex Revolution® home gym comes with 220 lbs (100kg) of resistance packs in 5, 10, 20, and 40-lb packs (2.27kg, 4.54kg, 9.07kg, 18.14kg).

Attaching resistance packs is simple. You simply select the resistance pack and slide it onto the shaft, making sure the rounded edge of the hole in the plate is matched up with the rounded edge of the shaft (see photos to the right). Once you push the pack all the way onto the shaft, press and turn the plate counterclockwise about 10 degrees until the locking tabs click into place. While applying pressure, turn the plate clockwise until the index marks on the packs are aligned.

**NOTE: It is extremely important to make sure that all six locking tabs engage to ensure proper and safe operation of the machine. Check that the pack is seated evenly, with no extra gap behind the bottom edge of the pack.**

You can choose any combination of resistance packs to suit your needs. Each pack needs to be installed in the same manner, by placing the pack onto the shaft, sliding it all the way to the housing, and turning it counterclockwise until the locking tabs engage. Then turn it clockwise so that the index marks on each pack are aligned. If you are using multiple resistance packs, each one contains locking mechanisms to stack multiple packs.

You can set resistance either symmetrically or offset. What this means is that you can set resistance to 40 lbs (18.14kg) on one side and 60 lbs (27.22kg) on the other side, or set both sides to 60 lbs, or 60 lbs on one side and nothing on the other side—or any variation like that. Setting resistance on one side is useful when doing one-sided exercises such as trunk rotations or hip extensions. You do not always have to have the same amount of resistance on each side. Doing so, however, is common for symmetrical exercises such as bench press or chest fly.

**For an animated demonstration of proper pack installation, visit the FAQ section of the Bowflex Revolution® website at [www.bowflexrevolution.com](http://www.bowflexrevolution.com).**



**Step 1: Place resistance plate on shaft, matching rounded top of hole with rounded top of shaft. Push resistance plate all the way onto shaft.**



**Step 2: While pressing pack towards machine, turn counterclockwise about 10 degrees until all six plate tabs lock into place. Then turn clockwise until index marks are aligned.**

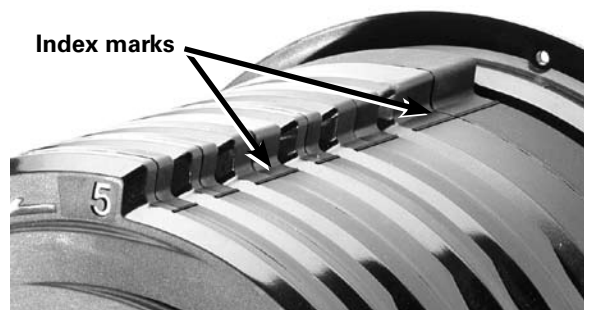



## Preparing for Use, Storing, and Moving

The Bowflex Revolution® home gym has the largest range of exercises ever offered by a Bowflex® home gym. Preparing your machine for use and maintaining your machine are simple.

### Preparing for Use

Before using your Bowflex Revolution® home gym, make sure you read through all of the safety warnings in this manual, and pay close heed to the warning labels on the machine. Additionally, inspect the machine prior to each use to ensure all parts are in good working order.

### Preparing to Exercise

To do exercises, read the instructions in this manual or on the exercise poster included with your machine. Each exercise uses a unique set of adjustable arm positions and cable connections. Using your Bowflex Revolution® home gym should be easy:

- Select the desired resistance plates
- Position the adjustable arms to the correct setting
- Attach cable clips to appropriate location
- Complete the exercise

A full description of each exercise is included later in this manual.

### Moving & Storing Your Machine

The full assembled weight of your machine is in excess of 300lbs. It's imperative that you observe all safety warnings and cautions when using or moving your machine. To move your machine, raise the adjustable arms to the 0 position and make sure they are locked in place. Raise the seat rail system, pull the pop pin on the lower seat rail at the leg extension assembly, and use the handle to lift the seat rail assembly into place. Grasp the handle on the back of the engine, and carefully lift the back of the machine to shift its weight to the transport wheels at the front of the Standing Platform. You can now roll the machine.



To raise seat rail assembly, pull pop pin (see above photo) and lift seat rail assembly until seat rail is upright and pin locks in place..

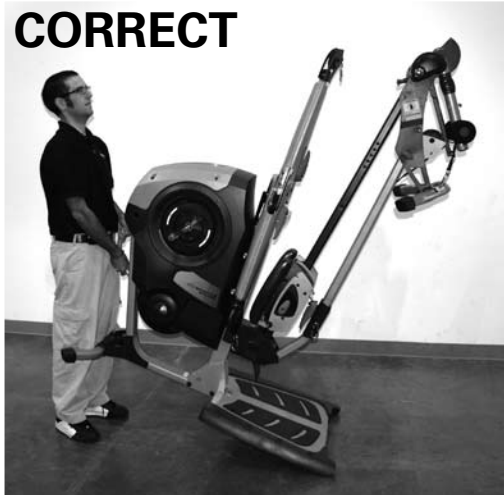

To move the machine, use handle on backside of engine and roll on the wheels integrated into the platform.



DO NOT USE HANDLE ON LEG EXTENSION ASSEMBLY TO MOVE UNIT.

# Maintenance

---

To store your machine, you can either leave it in the fully assembled, extended position, or you can raise the seat rail system to make a smaller footprint for storing. To raise the seat rail system, pull the pop pin on the lower seat rail at the leg extension assembly and use the handle to lift the seat rail assembly into place.

## Preventative Maintenance

Keeping your machine in good repair takes a minimal amount of time, and will ensure you have many years of use. In addition to preventative maintenance such as checking to make sure the unit is clean and free from defects, wiping down surfaces, and keeping attachments in a secure location, maintenance should be limited.

### Daily

Wipe down with a damp cloth. Pay special attention to areas where perspiration could settle.

### Monthly

Inspect the unit for loose parts, nuts, bolts, etc. Inspect ropes and straps for fraying or excessive wear.

### Yearly

Remove the Top Cover and inspect the condition of the internal components.

Look for fraying or excessive wear on straps, ropes, and moving parts, and replace as necessary.

## Adjusting Cable Tension

Pay close attention to maintenance of the cable tension. Over time and with heavy use, the cables are designed to give slightly. Located on the main engine housing is a tension control knob which allows you to increase the tension in the cables.

Checking for problem cable tension is simple.

1. Position the adjustable swing arms in the upper most position.
2. Check to see if clips at end of cable hang down or if they are tight against the pulley.
3. If cables don't have enough tension, use the tension control knob on the side of the machine to tighten the cables. (See image below).
4. To increase tension, pull tension knob outwards and turn the large pulley clockwise. The clip on the cable should be touching the pulley.



The cable clip should stop here.

In this image, the cable clip extends a few inches below the pulley, so there is not enough tension in the cable. The cable clip should be tight against the pulley with appropriate tension.



There are tension knobs on each side of the machine. To increase cable tension, pull knob and turn the large pulley clockwise. You'll know when you have enough tension when the cable retracts and the cable clip touches the pulley.

Large pulley. This is what you need to turn to increase the tension on the cable. Pull the tension knob and use your other hand to turn the large pulley clockwise.

## Cable Hookup for Leg Exercises

The drawings on this page show proper cable hookup when using the leg extension attachment. Please note that the freearms should be in position 9. The included Assembly Manual also contains information on how to attach both cables and machine attachments. Exercise Start and Finish photos on the pages to follow show where machine arms should be positioned, where cables should be attached, and how to position yourself for each exercise.

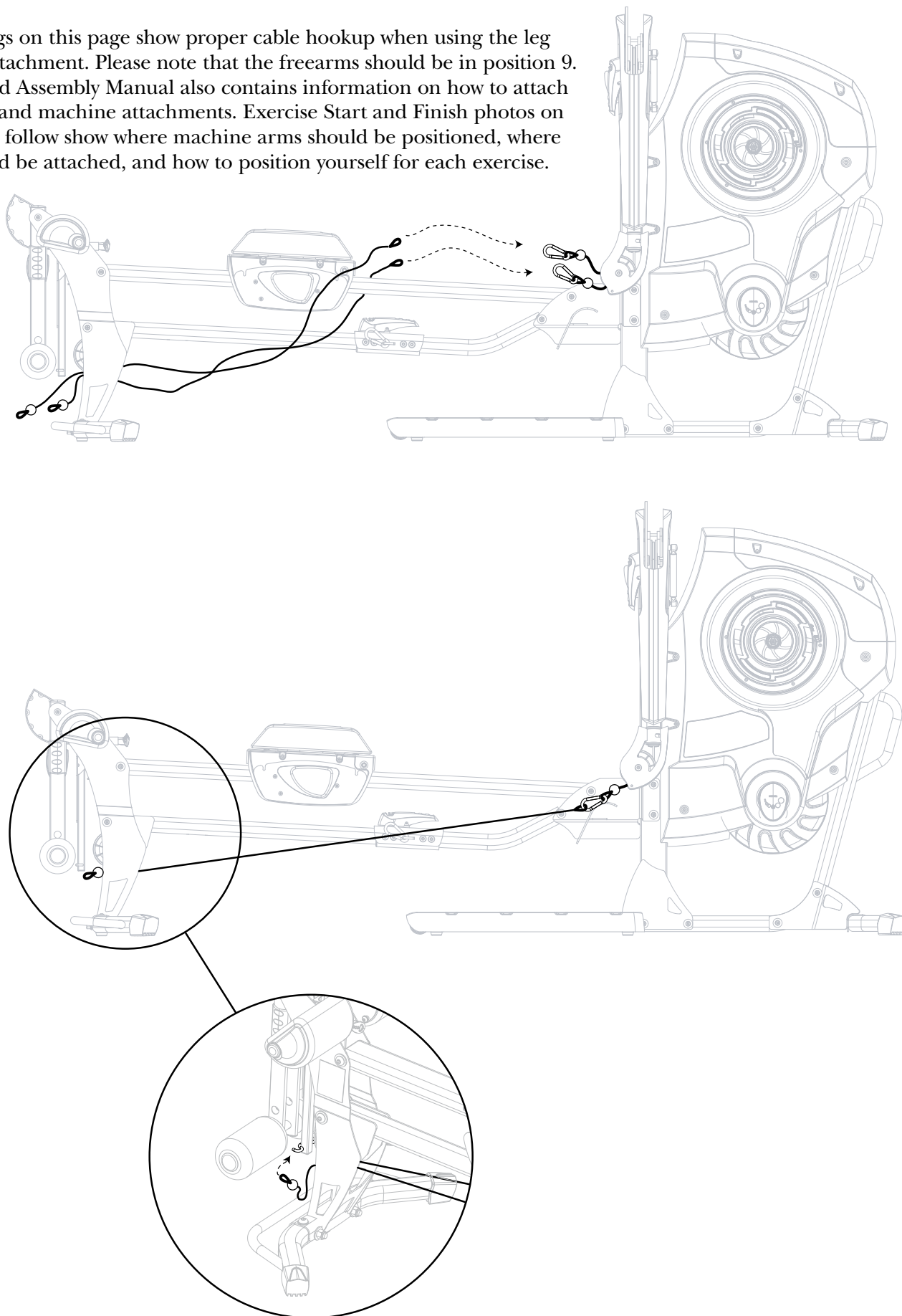

The drawings on this page show proper cable hookup for leg press exercises. Please note that the freearms should be in position 9.

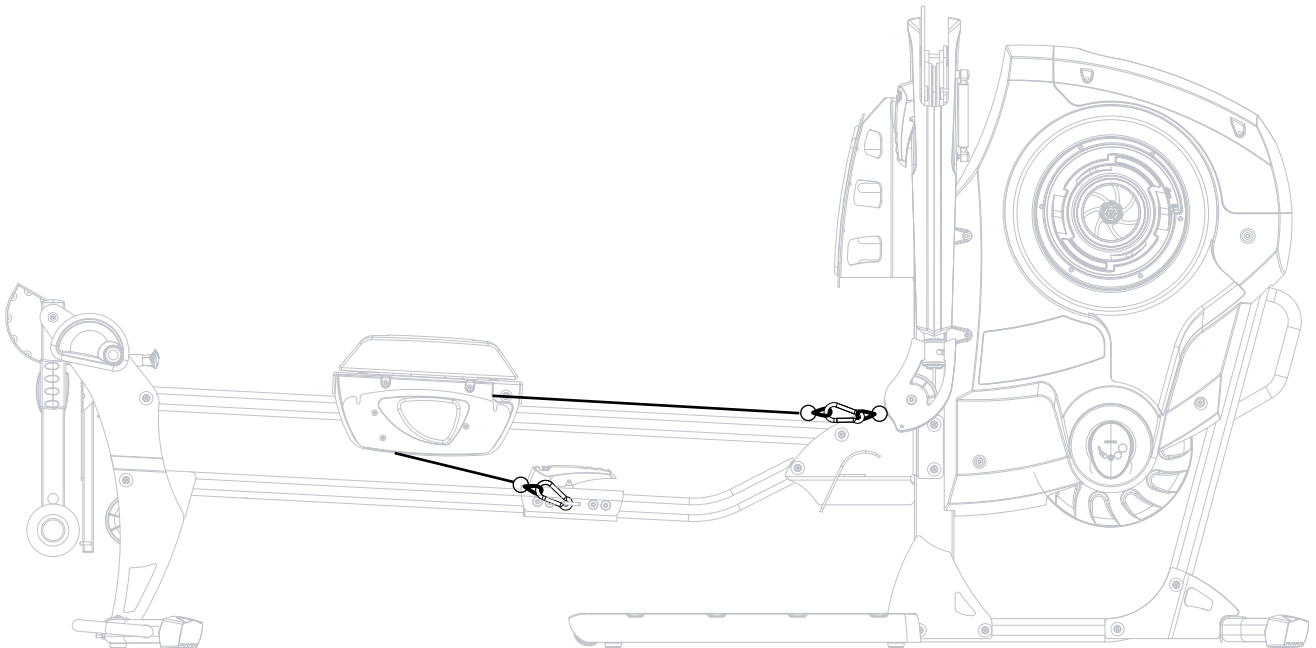
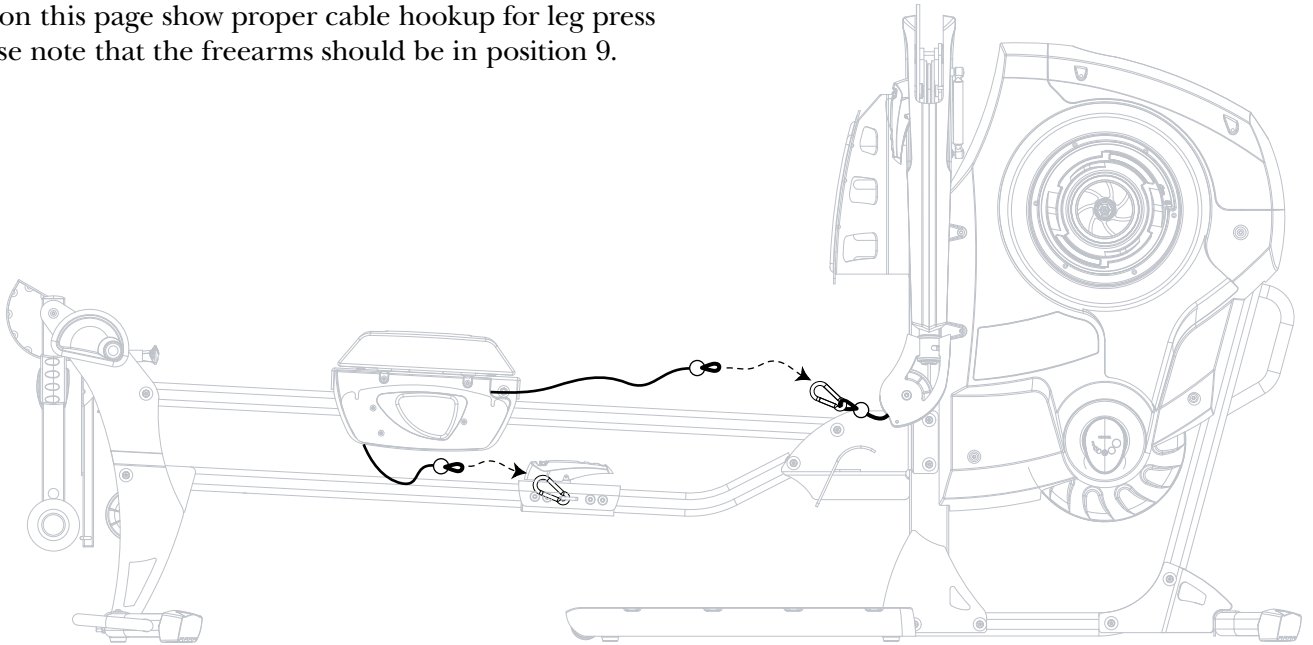

# Storing Leg Press Cables

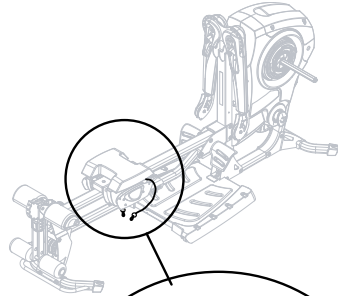

Step 1

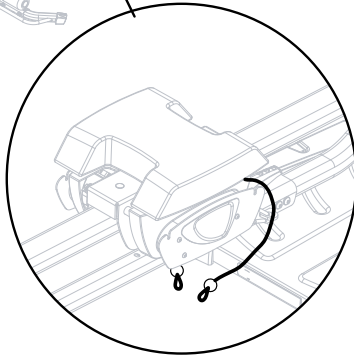

Side View

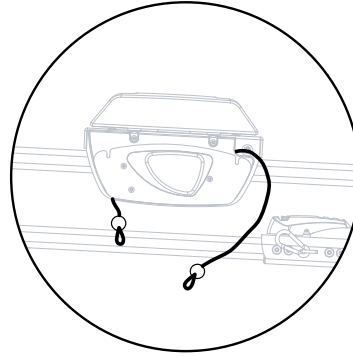

Step 1

Step 2

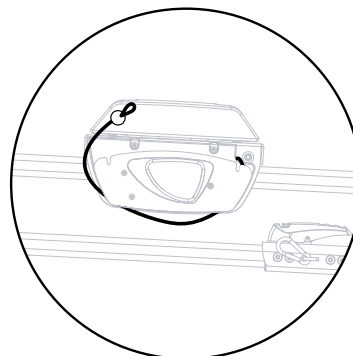
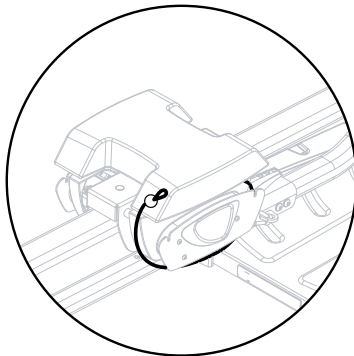

Step 2

Step 3

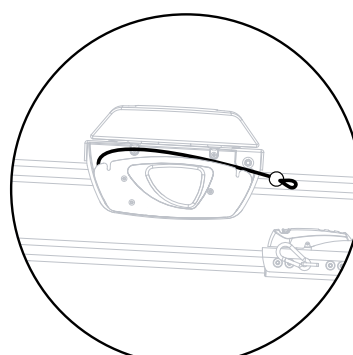
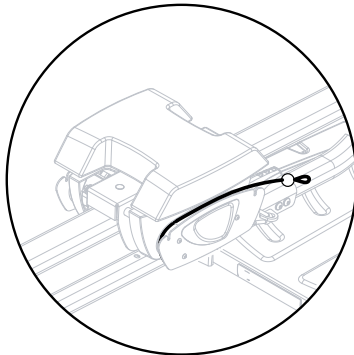

Step 3

Step 4

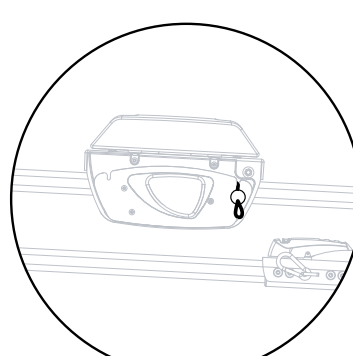
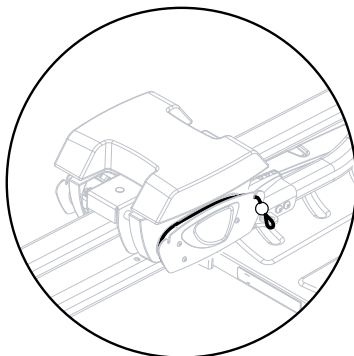

Step 4

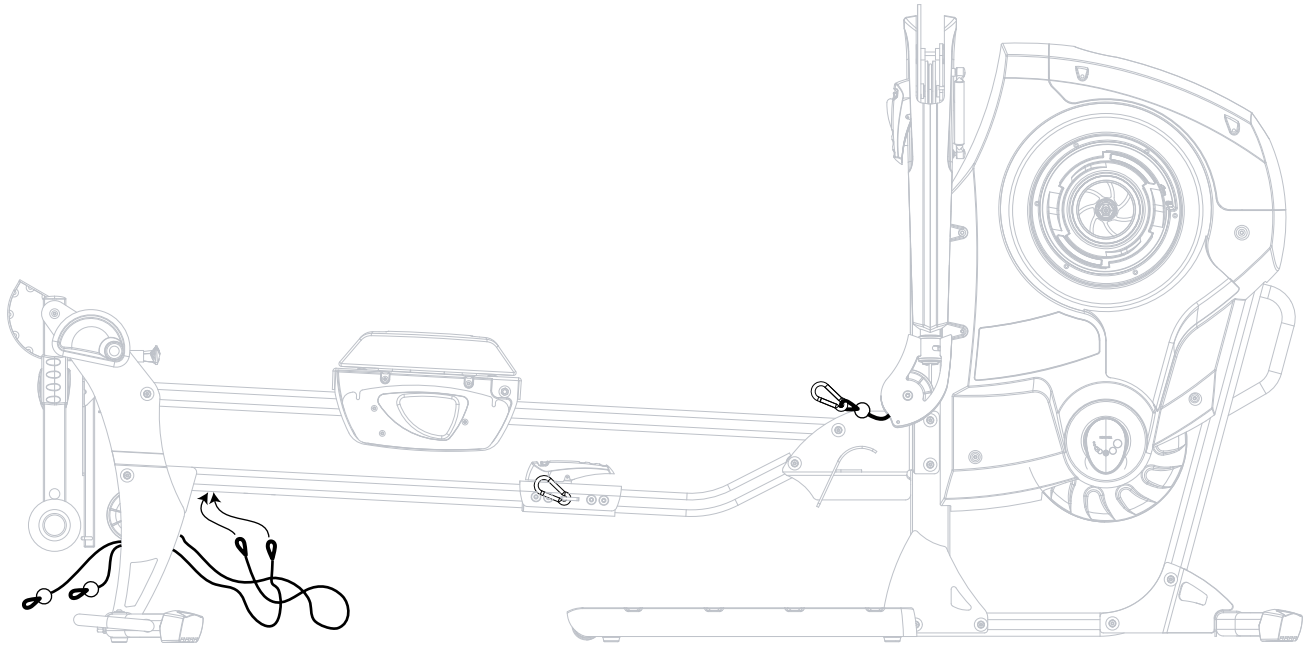

## Attaching Hand Grips and Foot Harnesses

Your Bowflex Revolution® home gym comes with a pair each of hand grips and foot harnesses.

### Hand Grips

You receive two hand grips with your Bowflex Revolution® home gym. Hand grips contain two D-rings on each grip, allowing for a shorter hand grip or longer hand grip, depending on the exercise.

For exercises that require a specific hand grip attachment, attaching to the D-ring closest to the handle will be referred to as using the “short hand grip”. Attachments to the D-ring furthest from the handle will be referred to as using the “long hand grip”.

Connect here for  
longer hand grip.

Connect here  
for shorter hand  
grip.

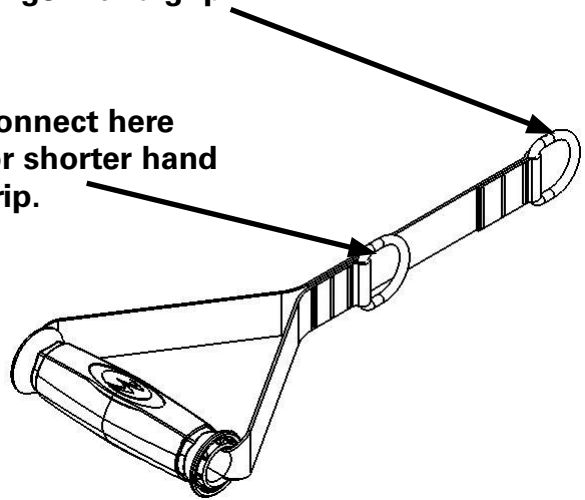

### Foot Harness

You additionally receive two foot harnesses. Foot harnesses are used for several types of leg exercises. The foot harnesses contain attachment rings on multiple sides.

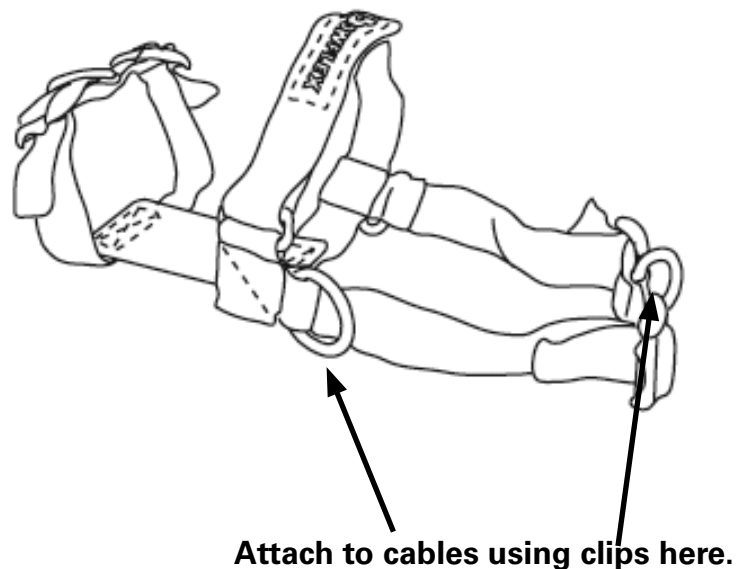



## Attaching Accessories, Benches, and Seats

Use the instructions on the following pages to attach each of the accessories/attachments.

### Leg Press Seatback

Use the leg press seatback when performing leg presses. Place the seatback in the opposite position to use as a back support for military presses and leg extensions. To attach this accessory, slide the leg press seatback arms into the seat roller assembly and tilt back to lock into place.

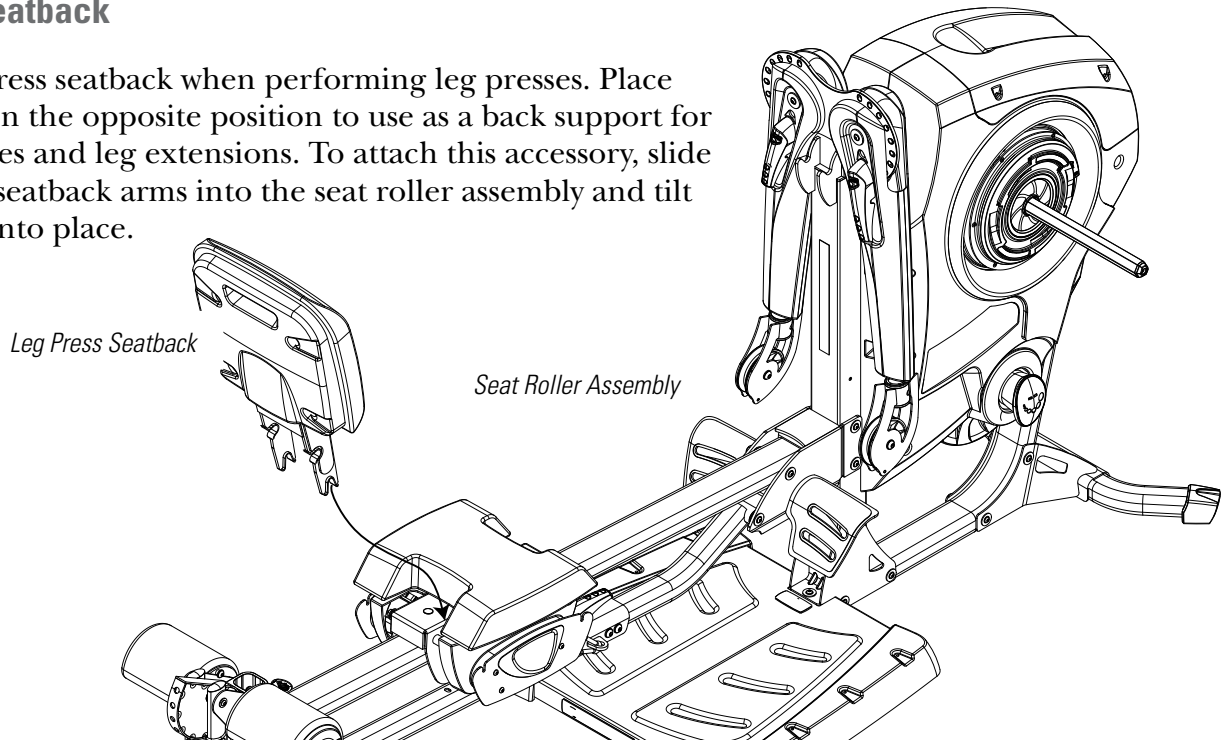

### Leg Press Plate

The leg press plate is used together with the leg press seatback when doing leg press exercises. To attach the leg press plate, place the cross bar on the leg press plate in the hooks on the main unit.

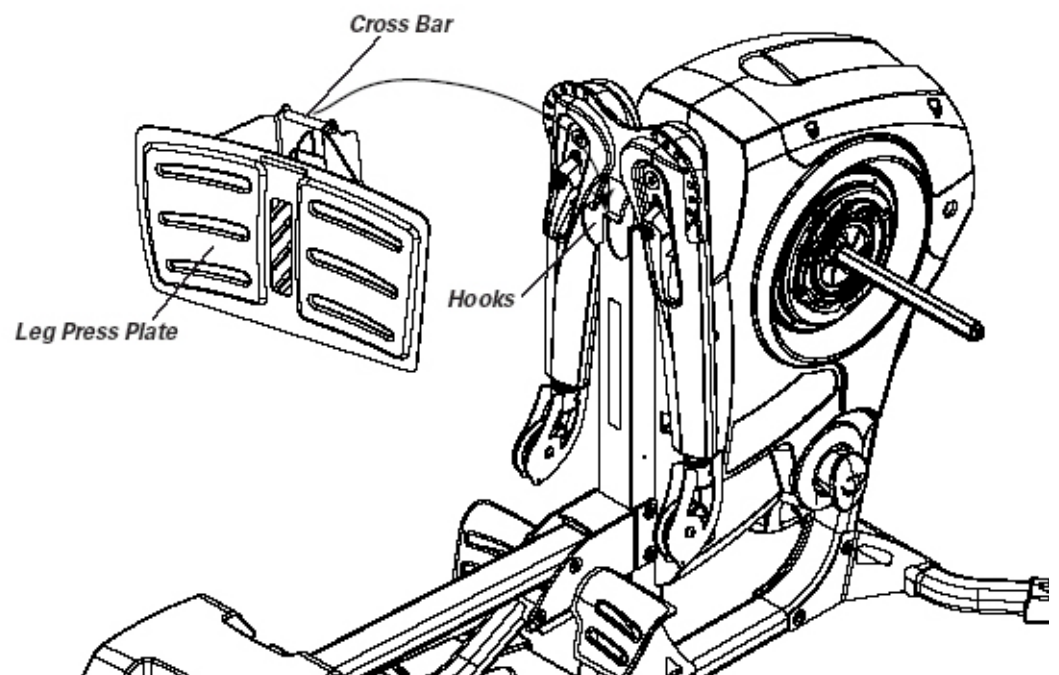

## Attaching Accessories, Benches, and Seats

### Preacher Curl

Pull out the pop-pin and slide the Preacher Curl Assembly into place. When the Preacher Curl is at the desired height, release the pop-pin to lock in place.

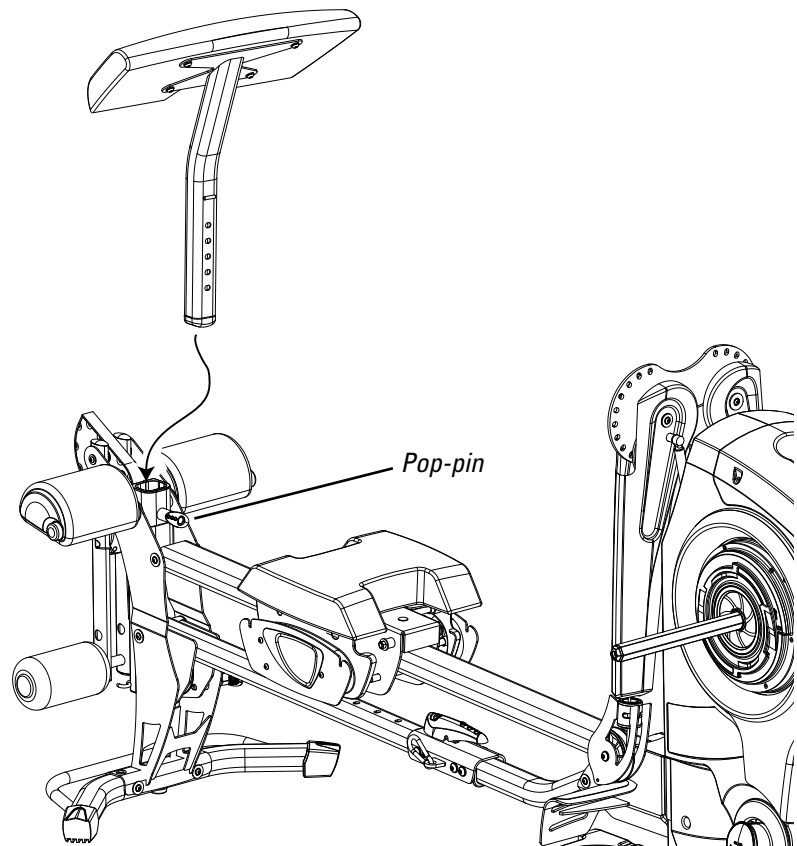

### Multi-Position Bench

The bench can be used in either of the following positions:

- Flat on the seat rail with the roller seat locked into the holes farthest from the engine on the rail, or
- At a 45-degree angle with the top of the bench hooked securely onto the hooks on the main frame assembly.

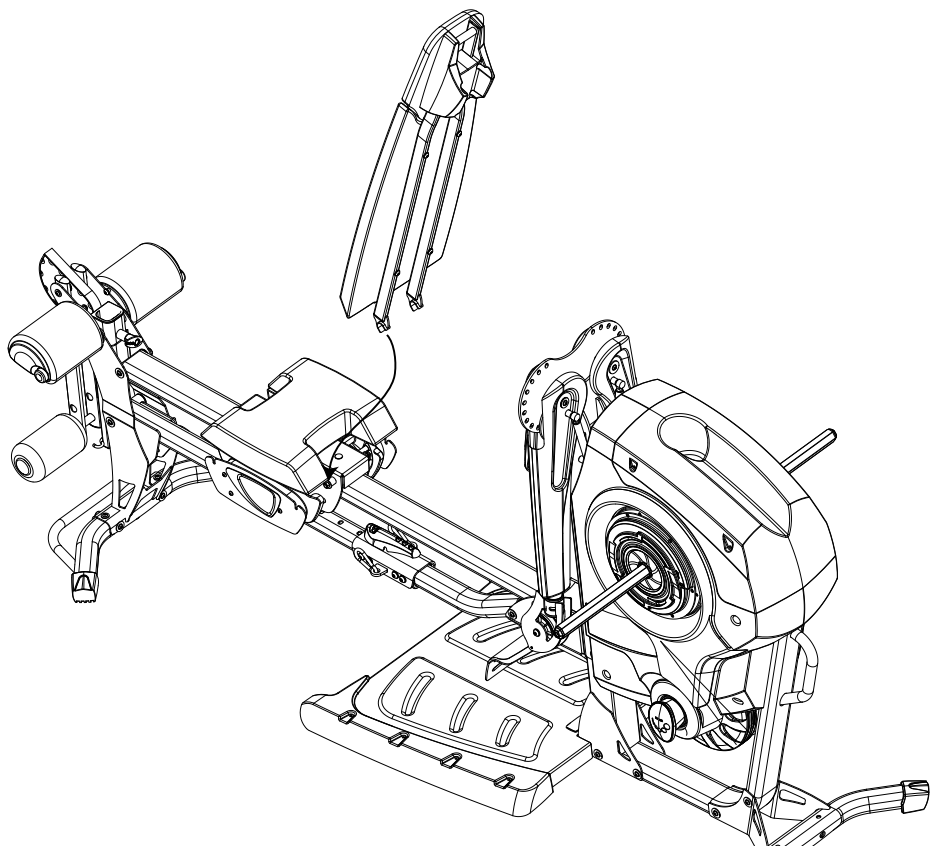

### WARNING

**Do not use the bench in any position other than the two positions listed above. To do so may cause the seat to fall during use, posing potential injury.**

## Companion Equipment

### Bowflex Revolution® Accessory Rack (ordered separately)

The Bowflex Revolution® home gym comes with many accessories and attachments to provide you with a wide variety of exercises. Between workouts, this specially designed accessory rack stores the gear that makes your home gym so versatile, so your workout area stays organized and ready for your next workout.

The accessory rack features:

Specially designed storage for many accessories including:

- Tall Seat Back
- Leg Press Plate
- Leg Press Seat Back
- Preacher Curl Assembly
- Resistance Packs
- Handgrips & Foot Harnesses

Heavy-duty steel construction for years of use

Stand Size: 2 ½' L x 2 ½' W x 3' H

Before



After



Check out the Bowflex Revolution® Accessory Rack and a wide selection of other great products available at [www.bowflex.com](http://www.bowflex.com)

## Defining Your Goals

Your body will do what you train it to do. That's why it's important to define your goals and focus on those goals. Here are some fitness components that will help you define your goals and choose your fitness program.

**Muscle Strength** is the maximum force you can exert against resistance at one time. Your muscle strength comes into play when you pick up a heavy bag of groceries or lift a small child. It is developed when a localized muscle is worked both positively (concentric) and negatively (eccentric) at a resistance great enough to perform only five to eight repetitions of the exercise before the muscle fails. Each set of repetitions is followed by a rest interval that typically runs three times longer than the set. Later, between exercise sessions, the muscle overcompensates for the stress and usually increases in both strength and size.

**Muscle Endurance** is the ability to perform repeated contractions. It comes into play when you cross-country ski or work on your feet all day. Endurance training addresses the slow twitch, endurance muscle fibers, which depend on oxygen for energy. To develop muscle endurance, use low resistance and high repetitions—about 15-20 repetitions in each set, three sets to each exercise, working the muscle only to fatigue.

**Muscle Power** is the combination of strength and speed of the muscular contraction. This is often misinterpreted as:

- a) Being directly associated with certain skill or sport; and/or
- b) Meaning that you must move fast.

Load is actually a more important factor than speed when attempting to improve power. When training to achieve muscular power, pick a resistance that fatigues you in the 3-5 repetition range. When performing these reps, it is more important to think of contracting the muscles faster rather than attempting to move faster. Performing sport simulation exercises usually results in a deterioration of the motor pattern or skill. The biomechanically sound method of improving power in your sport is to train for power using the correct joint movements, as described in this manual. Then practice the skill associated with your sport, learning to apply this newly achieved power.

**Body Composition** is the ratio of fat weight (fat) to lean weight (muscles, bones and tissue). As you age, the ratio shifts. The fat weight increases and the lean weight decreases. Training for muscle strength will generally increase muscle size and aerobic conditioning will help burn extra calories. Performing these two forms of exercise, either at different times or together, will create the greatest changes in body fat weight.

**Balanced Strength** and alignment is the result of equal strength developed in all parts of the body. It comes into play in your standing and sitting posture, and in your ability to perform just about any activity safely and effectively. Muscle weakness of the back will round the shoulders; weakness of the abdominals can cause lower back pain. You want a balance of muscle strength in front and back. In addition, you need a balance of strength between your middle, lower, and upper body.

**Flexibility** is the ability of a muscle or group of muscles to move the joint through a full range of motion. Flexibility comes into play when you execute an overhand serve or stretch for the top shelf in the kitchen. It is a cooperative movement of opposite muscle groups. When a muscle contracts, its opposite muscle group must relax for the action to occur. Increased flexibility means an increased range of motion, made possible by this simultaneous contracting and relaxing. Good flexibility is important in protecting the body from injury and can be achieved through the balanced strength training programs included in this manual.

**Cardiovascular Endurance** is the ability of the heart and lungs to supply oxygen and nutrients to exercising muscles over an extended period of time. It comes into play when you jog a mile or ride a bike. It is a critical component of overall fitness and health. Any exercise program must be supplemented with cardiovascular training, such as rowing on the Bowflex Revolution™.

# Defining Your Goals

## Reaching Your Goals

To reach your goals you must follow a consistent, well designed program that provides balanced development to all parts of the body and includes both aerobic and strength exercise. Only then will you meet your goals safely and efficiently.

The workout routines found in this manual are professionally designed and written to target specific fitness goals. Should you not find one specific program to your liking, you can design your own, based on sound information and the principles found in this manual.

## Designing Your Own Program

You may want to design your own personal program specifically geared to your goals and lifestyle. Designing a program is easy, as long as you follow these guidelines.

**Understand fitness and its components:** Improperly designed programs can be dangerous. Take some time to review this manual as well as other fitness guides.

**Know your current fitness level:** Before you start any fitness program you should consult a physician who will help you determine your current abilities.

**Identify your goals:** Goals are critical to choosing and designing an exercise program that fits and enhances your lifestyle, but so is strategy. It's important not to rush the process and try to accomplish too much too soon. That will lead to setbacks and discouragement. Instead, set a series of smaller achievable goals.

**Select complementary exercises:** Be sure to pair exercises that address compound joint movements and single joint movements. In addition, select exercises that address complementary muscle groups.

**Put first things first:** During each session, first work those muscle groups that need the most training.

**Remember your cardiovascular component:** Any fitness program must contain a cardiovascular fitness component to be complete. So complement your resistance training with aerobic exercise such as walking, running, bicycling or rowing on the Bowflex Revolution®.

**Training variables:** When designing your own program there are several variables that, when mixed properly, will equal the right fitness formula for you. In order to find the best formula, you must experiment with several combinations of variables. The variables are as follows:

- **Training Frequency:** The number of times you train per week. We recommend daily activity but not daily training of the same muscle group.
- **Training Intensity:** The amount of resistance and effort level of the individual used during your repetition.
- **Training Volume:** The number of repetitions and sets performed.
- **Rest intervals:** The time you rest between sets and the time you rest between workouts.

Once you've established a base of fitness, follow these basic principles:

- **Isolate muscle groups:** Focus work on specific muscle groups.
- **Progressive Loading:** The gradual systematic increase of repetitions, resistance and exercise period.

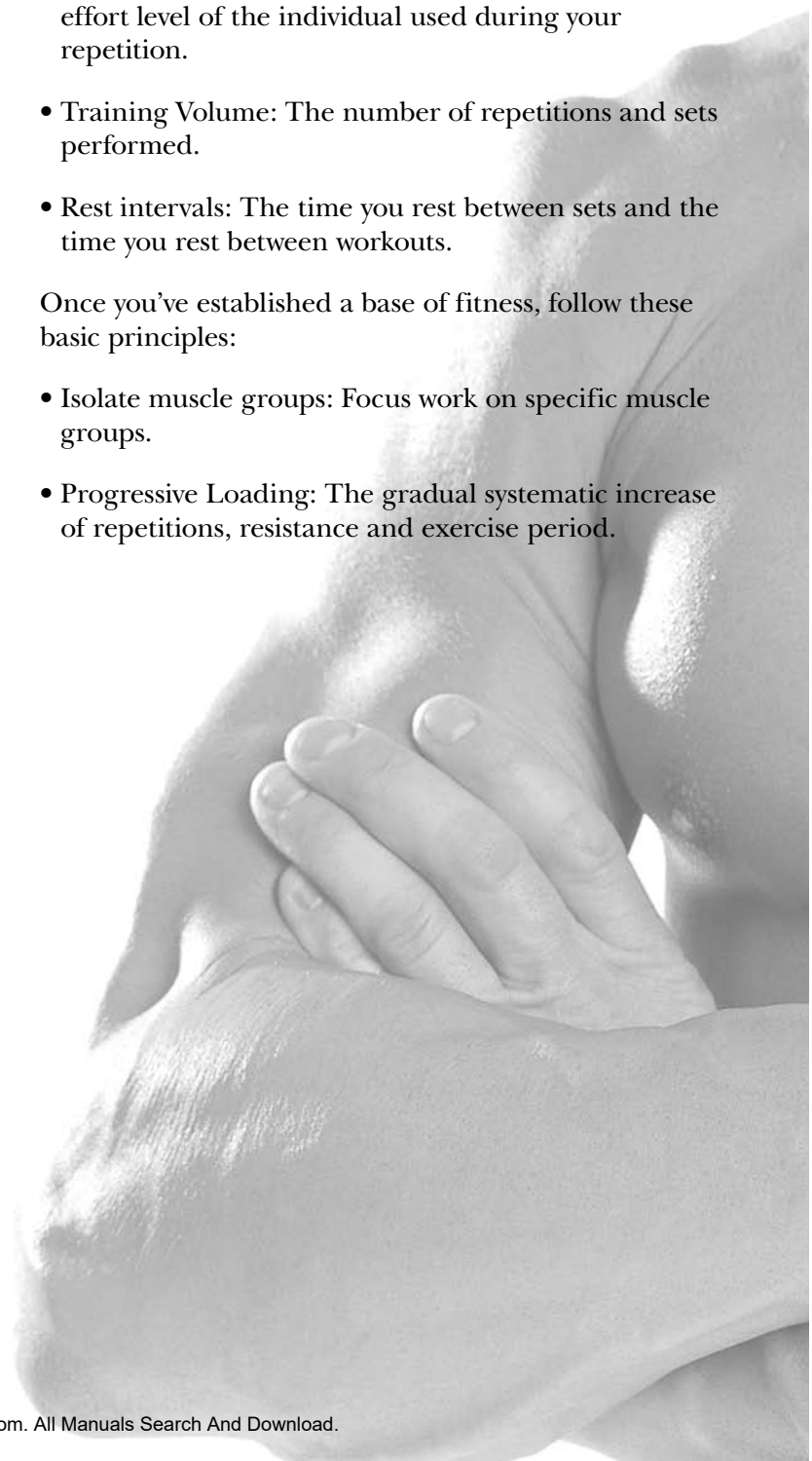

# Exercising Properly

## Working Out

A workout begins in your mind's eye. With concentration and visualization you can approach your workout with a positive, constructive attitude. A good pre-workout mental routine is to sit and relax, so you can focus on what you are about to do and think about achieving your end goal.

## Warming Up

We recommend that you warm up by rowing on the Bowflex Revolution® home gym.

## Aerobic Rowing Position:

Aerobic rowing on the Bowflex Revolution® home gym is done using the hand grips connected to the pulley cables

- Remove bench, unlock the seat by pulling the pop pin and locking it in the out position by rotating the pop pin. This allows the seat to move freely along the rail without locking into any one position.
- Sit on the seat facing the SpiraFlex® resistance packs.
- Move the arms into position 4 or 5.
- Position the arches of your feet on the footrest of the machine, knees bent comfortably.
- Grasp the hand grips and sit up straight with your spine in good alignment.



## Motion:

- Initiate the movement by extending the knees while simultaneously bending the arms and pinching the shoulder blades together.
- With the arms passing by the sides of your trunk, the handles should be near your torso as the knees near extension.

## Key Points:

- Do not lose spinal alignment — keep your chest lifted.
- If you bend forward during the return, bend at the hips, not the waist.

## Breathing

The most important part of breathing during exercise is, quite simply, that you do it. Breathing in or out during the actual performance is not dependent upon the direction of air flow relative to exertion. It is, in fact, a mechanical process that changes the position of your spine as your rib cage moves. Here are some tips for breathing:

- 1) Be cautious when you are concentrating or exerting effort. This is when you will probably hold your breath. **DO NOT** hold your breath. Do not exaggerate breathing. Depth of inhalation and exhalation should be natural for the situation.
- 2) Allow breathing to occur naturally. Don't force it.

## Performing Your Routine

The workout portion of your fitness routine is the series of exercises devoted to your particular goals. Remember, make sure to have fun!

## Cool Down

An essential part of the exercise routine is the cool down. Gradually reduce the level of exercise intensity so that blood does not accumulate in one muscle group, but continues to circulate at a decreasing rate. We recommend the rowing exercise for the cool down. Remember to gradually move yourself into a relaxed state.

# The Workouts

## 20 Minute Better Body Workout

**Frequency: 3 Days Per Week (M-W-F)    Time: About 20 Minutes**

Start by performing one set of each exercise. Warm up with a light resistance exercise that you can perform easily for 5 -10 reps without fatiguing. Focus on practicing and learning your technique before increasing the resistance. Then move to a more challenging resistance you can perform for no less than 10 reps and no more than 15 reps without your form deteriorating. As you become stronger, you can advance to two sets for each exercise. Complete all sets of each exercise before moving on to the next. Rest 30 to 45 seconds between sets. Move slowly on each rep. Use a pace that will allow you to stop the movement instantly at any point in the rep. Count three seconds up and three seconds down and work to fatigue during each set.

Body Part	Exercise	Sets	Reps
Back	Seated Lat Row	1-2	10-15
Shoulders	Rear Delt Row	1-2	10-15
Arms	Lying Triceps Extension	1-2	10-15
	Standing Biceps Curl	1-2	10-15
Trunk	Low Back Extension	1-2	10-15
	Resisted Abdominal Crunch	1-2	10-15
Chest	Bench Press	1-2	10-15
Legs	Leg Extension	1-2	10-15
	Leg Curl	1-2	10-15

## Advanced General Conditioning

**Frequency: 4 Days Per Week (M-T-TH-F)    Time: About 35-45 Minutes**

When you are proficient in performing the exercise techniques of the above routine and are no longer realizing results, or if you become bored, it is time to change your program. You can increase your training with this “split system” routine that works opposing muscle groups on different days. To do this, you’ll increase your resistance when you can perform 12 reps perfectly, and you’ll increase your volume by performing more sets and more exercises. Move slowly on each rep. Use a pace that will allow you to stop the movement instantly at any point in the rep. Count three seconds up and three seconds down and work to fatigue during each set.

Day 1 & 3

Body Part	Exercise	Sets	Reps
Chest	Standing Chest Press	1-3	10-12
Shoulders	Standing Shoulder Press	1-3	10-12
Arms	Rope Pushdown	1-3	10-12
	Standing French Press	1-3	10-12
Legs	Leg Press	1-3	10-12
	Seated Calf Raise	1-3	10-12

Day 2 & 4

Body Part	Exercise	Sets	Reps
Back	Standing Lat Row	1-3	10-12
	Stiff Arm Pulldown	1-3	10-12
Shoulders	Standing Cable Cross Rear Deltoid Row	1-3	10-12
Arms	Standing Biceps Curl	1-3	10-12
	Resisted Dip	1-3	10-12
Trunk	Trunk Rotation	1-3	10-12
	Standing Low Back Extension	1-3	10-12
	Seated Resisted Abdominal Crunch	1-3	10-12

# The Workouts

## 20 Minute Upper/Lower Body

**Frequency: 4 Days Per Week (M-T-T-H-F)      Time: About 20 Minutes**

This program provides you with a quick and effective workout that combines muscle conditioning with some cardiovascular benefits. Do this routine when you are limited in time or just want a variation to your normal routine. Perform this program training 2 days, resting 1 to 2. Perform all exercises to near failure, stopping at the point that your technique starts to deteriorate. Rest only 20-30 seconds between sets. As you get stronger, increase the number of sets you perform. Move slowly on each rep. Use a pace that will allow you to stop the movement instantly at any point in the rep. Count three seconds up and three seconds down and work to fatigue during each set.

DAY 1 & 3

Body Part	Exercise	Sets	Reps
Chest	Bench Press	1-3	12-15
Back	Seated Lat Row	1-3	12-15
Shoulders	Seated Shoulder Press	1-3	12-15
Arms	French Press	1-3	12-15
	Standing Biceps Curl	1-3	12-15

DAY 2 & 4

Body Part	Exercise	Sets	Reps
Legs	Leg Extension	1-3	12-15
	Leg Curl	1-3	12-15
	Leg Press	1-3	12-15
	Seated Calf Raise	1-3	12-15
Trunk	Seated Low Back Extension	1-3	10-12
	Seated Resisted Abdominal Crunch	1-3	10-12



# The Workouts

## Body Building

**Frequency: 3 Days On, 1 Day Off**      **Time: About 45-60 Minutes**

Body building requires focused concentration and dedication to training, as well as proper eating habits. Train each muscle group to failure before moving on to the next exercise. Do not neglect any muscle group. If needed, include an aerobic activity to increase your caloric expenditure and help to reduce your body fat levels to achieve a defined muscular look. Rest 30-60 seconds between each set and exercise. Focus on proper form. Tighten the muscle before you move, squeeze the muscle as you move, cramp the muscle at the point of full contraction, and resist the movement as you lower the weight. Move slowly on each rep. Use a pace that will allow you to stop the movement instantly at any point in the rep. Count three seconds up and three seconds down and work to fatigue during each set.

### DAY 1

Body Part	Exercise	Sets	Reps
Chest	Bench Press	2-4	8-12
	Decline Chest Fly	2-4	8-12
Shoulders	Seated Shoulder Press	2-4	8-12
	Rear Deltoid Row	2-4	8-12
	Standing Lateral Raise	2-4	8-12
	Shoulder Shrug	2-4	8-12

### DAY 2

Body Part	Exercise	Sets	Reps
Back	Seated Lat Rows	2-4	8-12
	Narrow Pulldown w/ Hand Grips	2-4	8-12
Arms	Standing Biceps Curl	2-4	8-12
	Standing Hammer Grip Curls	2-4	8-12
	Seated Triceps Extension	2-4	8-12
	Seated French Press	2-4	8-12

### DAY 3

Body Part	Exercise	Sets	Reps
Legs	Standing Hip Extension	2-4	8-12
	Leg Extension	2-4	8-12
	Leg Curl	1-3	8-12
	Leg Press	2-4	8-12
	Seated Calf Raise	2-4	12-15
Trunk	Seated Low Back Extension	2-4	8-12
	Seated Resisted Abdominal Crunch	2-4	8-12
	Seated Resisted Oblique Crunch	2-4	8-12
Aerobic	Aerobic Rowing	Progress up to 15-25 minutes	

# The Workouts

## Circuit Training – Anaerobic/Cardiovascular

**Frequency: 2-3 Times Per Week**

**Time: About 20-45 Minutes**

Circuit training is a great way to achieve the benefits of strength training and cardiovascular training in one quick, challenging routine. The idea is to move quickly from exercise to exercise, taking only as much rest between sets as it takes to set up the next exercise (less than 20 seconds). One circuit equals one set of each exercise. Initially, start with completing one round of Circuit 1. Then add an additional round of the same circuit. Once you reach three rounds of Circuit 1, add one round of Circuit 2. Add additional rounds of Circuit 2 as your fitness level increases. Repeat process with Circuit 3. Do not let your heart rate exceed 220 minus your age. Perform each rep of each exercise slowly and with perfect technique. Count three seconds up and three seconds down. Warm-up with 5-15 minutes of rowing or some other aerobic exercise before starting your circuits.

### Circuit 1

Body Part	Exercise	Reps
Chest	Standing Chest Press	8-12
Legs	Standing Leg Kickback	8-12
Back	Standing Lat Row Alternating	8-12
Legs	Standing Hip Abduction	8-12
Trunk	Standing Trunk Rotation	8-12

### Circuit 2

Body Part	Exercise	Reps
Shoulders	Seated Shoulder Press	8-12
Back	Lying Lat fly	8-12
Trunk	Seated Low Back Extension	8-12
Arms	Standing Biceps Curl	8-12
Legs	Leg Press	8-12

### Circuit 3

Body Part	Exercise	Reps
Shoulders	Standing Rear Deltoid Row	8-12
Arms	Rope Pushdown	8-12
Trunk	Standing Resisted Oblique Crunch	8-12
Legs	Leg Extension	8-12
	Leg Curl	8-12

# The Workouts

## True Aerobic Circuit Training

**Frequency: 2-3 Times Per Week**

**Time: About 20-60 Minutes**

Circuit training is a great way to achieve the benefits of strength training and cardiovascular training in one quick, challenging routine. By returning to the aerobic rowing exercise between each set you are increasing your aerobic capacity, endurance and burning fat as energy. The idea is to move quickly from exercise to exercise, taking only as much rest between sets as it takes to set up the next exercise (less than 20 seconds). One circuit equals one set of each exercise. Initially, start with completing one round of Circuit 1. Then add an additional round of the same circuit. Once you reach three rounds of Circuit 1, add one round of Circuit 2. Add additional rounds of Circuit 2 as your fitness level increases. Do not let your heart rate exceed 220 minus your age. Perform each rep of each exercise slowly and with perfect technique. Count three seconds up and three seconds down.

Warm-up with 5-15 minutes of rowing or some other aerobic exercise before starting your circuits.

### Circuit 1

Body Part	Exercise	Reps
Chest	Standing Chest Press	8-12
Aerobic Rowing	30 - 60 Seconds	
Legs	Standing Hip Extension	8-12
Aerobic Rowing	30 - 60 Seconds	
Back	Seated Lat Row	8-12
Aerobic Rowing	30 - 60 Seconds	
Legs	Standing Leg Kickback	8-12
Aerobic Rowing	30 - 60 Seconds	
Trunk	Standing Oblique Crunch	8-12
Aerobic Rowing	30 - 60 Seconds	

### Circuit 2

Body Part	Exercise	Reps
Shoulders	Shoulder Shrug	8-12
Aerobic Rowing	30 - 60 Seconds	
Legs	Standing Hip Flexion w/Knee Flexion	8-12
Aerobic Rowing	30 - 60 Seconds	
Back	Stiff Arm Pulldown	8-12
Aerobic Rowing	30 - 60 Seconds	
Trunk	Standing Low Back Extension	8-12
Aerobic Rowing	30 - 60 Seconds	
Arms	Standing Biceps Curl	8-12

# The Workouts

## Strength Training

**Frequency: 3 Days Per Week (M-W-F) Time: About 45-60 Minutes**

This program is designed to emphasize overall strength development. This is an advanced routine to be used only after you have progressed from the advanced general conditioning routine and only after you have perfected your exercise techniques. Work each set to near exhaustion. If you can perform more than 5 to 8 reps, you should increase your resistance 5 pounds and decrease your reps to 5. Rest 60 - 120 seconds between each set and exercise. Focus on proper form. Tighten the muscle before you move, squeeze the muscle as you move, cramp the muscle at the point of full contraction, and resist the movement as you lower the weight. Move slowly on each rep. Use a pace that will allow you to stop the movement instantly at any point in the rep. Count two seconds up and four seconds down and work to fatigue during each set.

Day 1

Body Part	Exercise	Sets	Reps
Chest	Bench Press	2-4	5-8
	Decline Chest Press	2-4	5-8
Shoulders	Seated Shoulder Press	2-4	5-8
	Seated Lateral Raise	2-4	5-8
	Rear Deltoid Row	2-4	5-8
	Shoulder Shrug	2-4	5-8

Day 2

Body Part	Exercise	Sets	Reps
Back	Seated Lat Row	2-4	5-8
	Narrow Lat Pulldown	2-4	5-8
Arms	Standing Biceps Curl	2-4	5-8
	Standing Biceps Curl- Shoulder Ext	2-4	5-8
	Triceps Kickback	2-4	5-8
	Rope Pushdown	2-4	5-8

Day 3

Body Part	Exercise	Sets	Reps
Legs	Leg Press	2-4	5-8
	Seated Calf Raise	2-4	5-8
	Leg Extension	2-4	5-8
	Prone Leg Curl	2-4	5-8
Trunk	Seated Low Back Extension	2-4	8-12
	Resisted Abdominal Crunch	2-4	5-8

# Exercises

## A Revolutionary Way to Exercise

The Bowflex Revolution® home gym provides an unparalleled number of exercises, with more than 90 exercises and over 400 total variations. You can switch quickly between hundreds of exercises with less setup time than most gym machines. That means a shorter workout while maintaining a higher, calorie-burning heart rate.

This manual and the included poster provide information on a large number of these exercises, but feel free to vary the exercises to meet your needs. Using the adjustable freearms, you can set the arms at 8 for one exercise, and exercise an entirely different set of muscles by simply moving the freearms to 6 or 7 and doing the same exercise.

Changing exercises is simple. The freearms rotate between positions 0 and 9, with 0 being straight up and 9 being straight down. That means you have ten arm positions to work out with, each one providing a slightly different variation of each exercise. Switching cables between exercises is simple with snap-hook attachments.

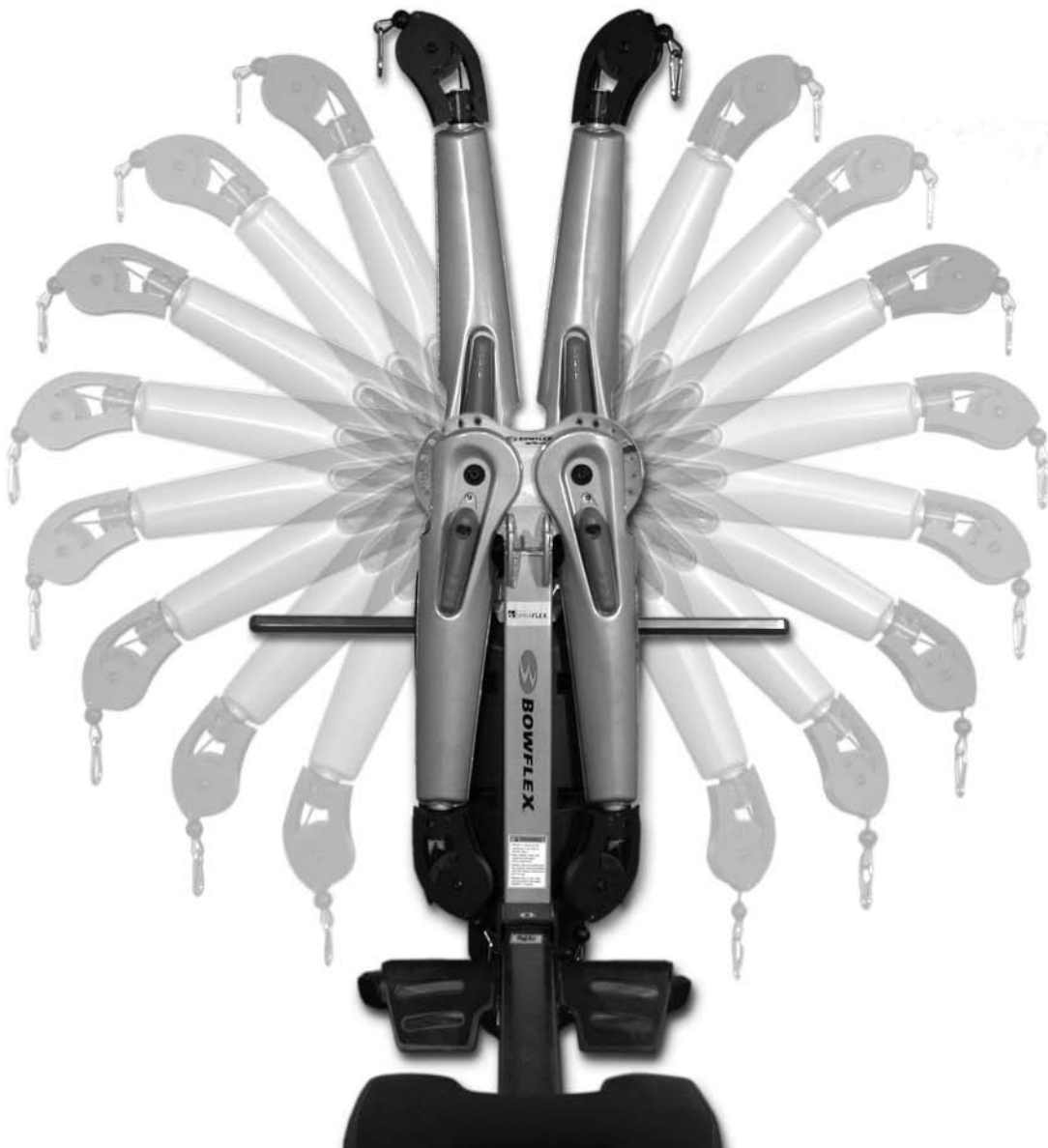

## Chest Exercises

### Bench Press — Shoulder Horizontal Adduction (and elbow extension)

#### Muscles worked:

Pectoralis Major; Deltoids; Triceps

#### Bench Position:

45° incline

#### Accessory:

Long Hand Grips

#### Adjustable Arm Position:

7 or 8

#### Success Tips

- Maintain a 90° angle between upper arms and torso throughout motion.
- Keep chest muscles tightened. Limit and control your range of motion.
- Keep knees bent, feet on floor, head back against bench.
- Do not let your elbows travel behind your shoulders.
- Keep shoulder blades pinched together and maintain good spinal alignment.



#### START

- Curl grips up into position.
- Keep elbows back and out to your sides.



#### FINISH

- Press straight out a way from chest.
- Return to Start position slowly.

### Chest Fly — Shoulder Horizontal Adduction (elbow stabilized)

#### Muscles worked:

Pectoralis Major; Anterior Deltoid

#### Bench Position:

45° incline

#### Accessory:

Long Hand Grips

#### Adjustable Arm Position:

7 or 8

#### Success Tips

- Maintain a 60-90° angle between upper arms and torso during exercise.
- Keep chest muscles tightened. Limit and control your range of motion.
- Keep knees bent, feet on floor, head back against bench.
- Do not let your elbows travel behind your shoulders.
- To improve your pectoralis involvement, keep your shoulder blades pinched together throughout upward and downward movements.



#### START

- Grasp Hand Grips in both hands.
- Open your arms into a wide, elbow bent position. Keeping elbows and forearms below chest level, palms forward.
- Raise chest, pinch shoulder blades together, and maintain a slight, comfortable arch in your lower back.



#### FINISH

- Slowly press your arms forward and upward, straightening arms and moving your hands together.
- Slowly return to Start position

## Chest Exercises

### Resisted Punch — Shoulder Flexion, Elbow Extension, Scapular Protraction

#### Muscles worked:

Anterior Deltoid; Triceps; Pectoralis Major

#### Bench Position:

Flat Bench Back

#### Accessory:

Long Hand Grips

#### Adjustable Arm Position:

8 (up/center)

#### Success Tips

- Maintain an upright, erect posture as your trunk rotates with the punch.
- Keep knees bent and feet on floor.
- Maintain good spinal alignment.



START



FINISH

#### START

- Sit on the bench facing away from the engine.
- Reach behind your body and grasp the Hand Grips with an overhand grip, as shown above.
- Bend your elbows until your hands are level with your waist.

#### FINISH

- Using moderate speed, rotate your trunk and press your arm(s) forward to full extension, allowing shoulder blade to move forward at the end of the punch.
- Slowly return to the Start position. Do not relax the tension in your arm.
- You may vary this exercise by using bilateral movement with both arms or punching upward or downward.

### Lying Cable Crossover — Shoulder Adduction (elbow stabilized)

#### Muscles worked:

Pectoralis Major

#### Bench Position:

Flat

#### Accessory:

Long Hand Grips

#### Adjustable Arm Position:

6 or 7

#### Success Tips

- Keep chest lifted throughout exercise.
- Keep knees bent, feet on floor, head back against bench.



START



FINISH

#### START

- Lie flat on your back, head toward the engine. Position yourself far enough down the Bench to grasp the Hand Grips over your head with arms straight out to the side.
- Grasp the Hand Grips, palms facing down toward your feet.
- Tighten your abdominals to stabilize your spine. Maintain a slight, comfortable arch in your lower back.

#### FINISH

- Keep your elbows straight, while moving your arms in an arc upward and across your torso toward the opposite thigh.
- Control the return to the Start position by slowly moving your arms back to shoulder level, releasing the shoulder blades and keeping arms straight.

## Chest Exercises

### Decline Chest Fly

#### Muscles worked:

Pectoralis Major; Anterior Deltoid

#### Bench Position:

45° incline

#### Accessory:

Long Hand Grips

#### Adjustable Arm Position:

5, 6, or 7

#### Success Tips

- Maintain a 90° angle between your upper arms and your torso throughout the exercise.
- Limit and control the range of motion so that your elbows do not travel behind your shoulders.
- Keep your shoulder blades pinched together and maintain good spinal alignment.



START



FINISH

#### START

- Sit in the 45° position, reach straight behind your body, grasp the Hand Grips, and slightly bend your elbows with your palms facing forward.
- Keeping knees bent and feet flat on the floor, lay your head back against the bench.
- Start with your upper arms out to the sides, level with your shoulders.

#### FINISH

- Slowly move your arms parallel to the floor and inward, maintaining the elbow in a slightly bent position throughout the movement.
- Slowly return to the Start position keeping your chest muscles tightened during the entire motion.

### Incline Chest Fly

#### Muscles worked:

Pectoralis Major; Anterior Deltoid

#### Bench Position:

45° incline

#### Accessory:

Long Hand Grips

#### Adjustable Arm Position:

8, 9

#### Success Tips

- Maintain a 90° angle between your upper arms and your torso throughout the exercise.
- Limit and control the range of motion so that your elbows do not travel behind your shoulders.
- Keep your shoulder blades pinched together and maintain good spinal alignment.



START



FINISH

#### START

- Reach straight behind your body, grasp the Hand Grips, and slightly bend your elbows with your palms facing forward.
- Keeping knees bent and feet flat on the floor, lay your head back against the bench.
- Start with your upper arms out to the sides, level with your shoulders.

#### FINISH

- Slowly move your arms up and inward, maintaining the elbow in a slightly bent position throughout the movement.
- Slowly return to the Start position keeping your chest muscles tightened during the entire motion.



## Chest Exercises

### Standing Chest Press – Shoulder Horizontal Adduction (and elbow extension)

#### Muscles worked:

Pectoralis Major; Deltoids; Triceps. Also ankles, knees, hips and core in stabilization.

#### Bench Position:

Removed

#### Accessory:

Long Hand Grips

#### Adjustable Arm Position:

3,4 or 5

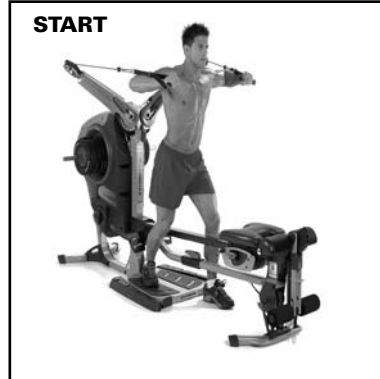

**START**



**FINISH**

#### Success Tips

- Stabilize body from your feet all the way up through your trunk.
- Maintain a 90° angle between upper arms and torso throughout the motion.
- Keep chest muscles tight, limit and control your range of motion.
- Keep knees slightly bent, feet flat on the floor and in a staggered step for stability.
- Keep shoulder blades pinched, chest lifted and a slight curve in the lower back.

#### START

- Grasp the Hand Grips so the cables are in line close to the front of your forearms.
- Stand with one foot forward and one foot back for added stability.
- Start with elbows bent to 90° and slightly behind or equal to the shoulders.

#### FINISH

- Press straight out away from your chest, bringing the handles together in front of you.
- Slowly return to the Start position, keeping tension on the chest throughout the motion.

### Standing Chest Press w/ Alternating Shoulder Movement

#### Muscles worked:

Pectoralis Major; Deltoids; Triceps. Also ankles, knees, hips and core in stabilization.

#### Bench Position:

Removed

#### Accessory:

Long Hand Grips

#### Adjustable Arm Position:

3,4 or 5



**START**



**FINISH**

#### Success Tips

- Stabilize body from your feet all the way up through your trunk.
- Maintain a 90° angle between upper arms and torso throughout the motion.
- Keep chest muscles tight, limit and control your range of motion.
- Keep knees slightly bent, feet flat on the floor and in a staggered step for stability.
- Keep shoulder blades pinched, chest lifted and a slight curve in the lower back.
- Do not allow your trunk to rotate during the motion.

#### START

- Grasp the Hand Grips so the cables are in line close to the front of your forearms.
- Stand with one foot forward and one foot back for added stability.
- Start with one elbow bent to 90° and slightly behind or equal to the shoulders, and the other arm straight out in front of you.

#### FINISH

- Press straight out away from your chest with one arm, as the other arm moves out and back. This is an alternating motion, so your arms will move in the opposite direction during the set.
- Slowly return each arm to the Start position, keeping tension on the chest throughout the motion.

## Chest Exercises

### Incline Chest Press – Shoulder Horizontal Adduction (and elbow extension)

#### Muscles worked:

Pectoralis Major; Deltoids; Triceps.

#### Bench Position:

45°

#### Accessory:

Long Hand Grips

#### Adjustable Arm Position:

7 or 8

#### Success Tips

- Maintain a 90° angle between upper arms and torso at the start of the press, and slightly higher than 90° at the finish.
- Keep chest muscles tight, limit and control your range of motion.
- Keep knees slightly bent, feet flat on the floor.
- Keep shoulder blades pinched, chest lifted and a slight curve in the lower back.



#### START



#### START

- Grasp the Hand Grips so the cables travel above the forearms.
- Keep your forearms in line with the cables at all times.
- Start with elbows bent to 90° and slightly behind or even with the shoulders.

#### FINISH



#### FINISH

- Press slightly upward, away from your chest, bringing the handles together in front of you at about 10° above your shoulders.
- Slowly return to the Start position, keeping tension on the chest throughout the motion.

### Standing Incline Chest Press – Shoulder Horizontal Adduction (and elbow extension)

#### Muscles worked:

Pectoralis Major; Deltoids; Triceps. Also ankles, knees, hips and core in stabilization.

#### Bench Position:

Removed

#### Accessory:

Long Hand Grips

#### Adjustable Arm Position:

4 or 5

#### Success Tips

- Stabilize body from your feet all the way up through your trunk.
- Maintain a 90° angle between upper arms and torso at the start of the press, and slightly higher than 90° at the finish.
- Keep chest muscles tight, limit and control your range of motion.
- Keep knees slightly bent, feet flat on the floor and in a staggered step for stability.
- Keep shoulder blades pinched, chest lifted and a slight curve in the lower back.



#### START



#### START

- Stand with one foot forward and one foot back for added stability.
- Start with elbows bent to 90° and slightly behind or even with the shoulders.

#### FINISH



#### FINISH

- Press slightly upward, away from your chest, bringing the handles together in front of you at about 10° above your shoulders.
- Slowly return to the Start position, keeping tension on the chest throughout the motion.

## Chest Exercises

### Standing Incline Chest Press w/ Alternating Motion – Shoulder Horizontal Adduction

#### Muscles worked:

Pectoralis Major; Deltoids; Triceps. Also ankles, knees, hips and core in stabilization.

#### Bench Position:

Removed

#### Accessory:

Long Hand Grips

#### Adjustable Arm Position:

4 or 5



**START**



**FINISH**

#### START

- Grasp the Hand Grips so the cables are in line close to the front of your forearms.
- Stand with one foot forward and one foot back for added stability.
- Start with elbows bent to 90° and slightly behind or even with the shoulders, and the other arm straight in front of you at a slight inclined angle about head high.

#### FINISH

- Press one arm slightly upward away from your chest, as the other arm moves out and back. This is an alternating motion, so your arms will move in the opposite direction during the set.
- Slowly return each arm to the Start position keeping tension on the chest throughout the motion.

#### Success Tips

- Stabilize body from your feet all the way up through your trunk.
- Maintain a 90° angle between upper arms and torso throughout the motion.
- Keep chest muscles tight, limit and control your range of motion.
- Keep knees slightly bent, feet flat on the floor and in a staggered step for stability.
- Keep shoulder blades pinched, chest lifted and a slight curve in the lower back.
- Do not allow your torso to rotate or bend side to side during the motion.

### Decline Chest Press – Shoulder Horizontal Adduction (and elbow extension)

#### Muscles worked:

Pectoralis Major; Deltoids; Triceps.

#### Bench Position:

45°

#### Accessory:

Long Hand Grips

#### Adjustable Arm Position:

7 or 8



**START**



**FINISH**

#### START

- Grasp the Hand Grips so the cables travel under the forearm.
- Keep your forearms in line with the cable at all times.
- Start with elbows back and upper arms 90° from your torso.
- Elbows should be 10° lower than the standard bench press position.

#### FINISH

- Press forward, straightening your arms while moving your hands toward the center and slightly downward about 10° below your shoulders.
- Do not lock your elbows.
- Slowly return to the Start position, keeping tension on the chest throughout the motion.

#### Success Tips

- Maintain a 90° angle between upper arms and torso at the start of the press, and slightly less than 90° at the finish.
- Keep chest muscles tight, limit and control your range of motion.
- Keep knees slightly bent, feet flat on the floor.
- Keep shoulder blades pinched, chest lifted and a slight curve in the lower back.

## Chest Exercises

### Standing Decline Chest Press – Shoulder Horizontal Adduction (and elbow extension)

#### Muscles worked:

Pectoralis Major; Deltoids; Triceps. Also ankles, knees, hips and core in stabilization.

#### Bench Position:

Removed

#### Accessory:

Long Hand Grips

#### Adjustable Arm Position:

3, 4 or 5

#### Success Tips

- Stabilize body from your feet all the way up through your trunk.
- Maintain a 90° angle between your upper arms and torso at the start of the motion, and slightly less than 90° at the finish.
- Keep chest muscles tight, limit and control your range of motion.
- Keep knees slightly bent, feet flat on the floor and in a staggered step for stability.
- Keep shoulderblades pinched, chest lifted and a slight curve in the lower back.



START



FINISH

#### START

- Grasp the Hand Grips so the cables travel under the forearm.
- Keep your forearms in line with the cable at all times.
- Start with elbows back and upper arms 90° from your torso.
- Elbows should be 10° lower than the standard bench press position.
- Stand with one foot forward and one foot back for added stability.

#### FINISH

- Press forward, straightening your arms while moving your hands toward the center and slightly downward about 10° below your shoulders.
- Do not lock your elbows.
- Slowly return to the Start position, keeping tension on the chest throughout the motion.

### Standing Decline Chest Press w/ Alternating Motion – Shoulder Horizontal Adduction

#### Muscles worked:

Pectoralis Major; Deltoids; Triceps. Also ankles, knees, hips and core in stabilization.

#### Bench Position:

Removed

#### Accessory:

Long Hand Grips

#### Adjustable Arm Position:

3, 4 or 5

#### Success Tips

- Stabilize body from your feet all the way up through your trunk.
- Keep chest muscles tight, limit and control your range of motion.
- Keep knees slightly bent, feet flat on the floor and in a staggered step for stability.
- Keep shoulderblades pinched, chest lifted and a slight curve in the lower back.
- Do not allow your torso to rotate or bend side to side during the motion.



START



FINISH

#### START

- Grasp the Hand Grips so the cables are in line and close to the front of your forearms.
- Stand with one foot forward and one foot back for added stability.
- Start with one elbow bent to 90° and slightly behind or even with the shoulder, the other arm straight in front of you 10° lower. Do not lock the elbow.

#### FINISH

- Press one arm slightly downward away from your chest, as the other arm moves out and back. This is an alternating motion, so your arms will move in the opposite direction during the set.
- Slowly return each arm to the Start position, keeping tension on the chest throughout the motion.

## Chest Exercises

### Standing Chest Fly – Shoulder Horizontal Adduction (elbow stabilization)

#### Muscles worked:

Pectoralis Major; Deltoids. Also ankles, knees, hips and core in stabilization.

#### Bench Position:

Removed

#### Accessory:

Long Hand Grips

#### Adjustable Arm Position:

4, 5 or 6

#### Success Tips

- Stabilize body from your feet all the way up through your trunk.
- Maintain a 90° angle between upper arms and torso throughout the motion.
- Keep chest muscles tight, limit and control your range of motion.
- Keep knees slightly bent, feet flat on the floor and in a staggered step for stability.
- Keep shoulder blades pinched, chest lifted and a slight curve in the lower back.



#### START



#### START

- Grasp the Hand Grips so the cables lie close to the front of your forearms and palms facing forward.
- Stand with one foot forward and one foot back for added stability.
- Stabilize the elbows so they are slightly bent and slightly behind or equal to the shoulders.

#### FINISH



#### FINISH

- Slowly move the arms forward and inward, bringing the handles together in front of you.
- Slowly return to the Start position, keeping tension on the chest throughout the motion.

### Standing Single Arm Chest Fly – Shoulder Horizontal Adduction (elbow stabilization)

#### Muscles worked:

Pectoralis Major; Deltoids. Also ankles, knees, hips and core in stabilization.

#### Bench Position:

Removed

#### Accessory:

Long Hand Grips

#### Adjustable Arm Position:

4 or 5

#### Success Tips

- Stabilize body from your feet all the way up through your trunk.
- Maintain a 90° angle between upper arm and torso throughout the motion.
- Keep chest muscles tight, limit and control your range of motion.
- Keep knees slightly bent, feet flat on the floor and in a staggered step for stability.
- Keep shoulder blade pinched, chest lifted and a slight curve in the lower back.
- Do not lean sideways or turn the trunk during the motion.



#### START



#### START

- Grab the handle so the cable lies close to the front of your forearm and palm face forward.
- Stand with one foot forward and one foot back for added stability.
- Stabilize the elbow so it is slightly bent and slightly behind or equal to the shoulder.

#### FINISH



#### FINISH

- Slowly move the arm forward and inward, bringing the handle in front of you.
- Slowly return to the Start position, keeping tension on the chest throughout the motion.

## Chest Exercises

### Standing Incline Chest Fly – Shoulder Horizontal Adduction (elbow stabilization)

#### Muscles worked:

Pectoralis Major; Deltoids. Also ankles, knees, hips and core in stabilization.

#### Bench Position:

Removed

#### Accessory:

Long Hand Grips

#### Adjustable Arm Position:

4, 5 or 6

#### Success Tips

- Stabilize body from your feet all the way up through your trunk.
- Keep chest muscles tight, limit and control your range of motion.
- Keep knees slightly bent, feet flat on the floor and in a staggered step for stability.
- Keep shoulder blades pinched, chest lifted and a slight curve in the lower back.



**START**



**FINISH**

#### START

- Grasp the Hand Grips so the cables lie close to the front of your forearms, and palms face forward.
- Stand with one foot forward and one foot back for added stability.
- Stabilize the elbows so they are slightly bent and slightly behind or even with the shoulders.

#### FINISH

- Slowly move the arms slightly upward and inward, bringing the handles together in front of you at about neck/chin height.
- Slowly return to the Start position, keeping tension on the chest throughout the motion.

### Standing Decline Chest Fly – Shoulder Horizontal Adduction (elbow stabilization)

#### Muscles worked:

Pectoralis Major; Deltoids. Also ankles, knees, hips and core in stabilization.

#### Bench Position:

Removed

#### Accessory:

Long Hand Grips

#### Adjustable Arm Position:

4 or 5

#### Success Tips

- Stabilize body from your feet all the way up through your trunk.
- Keep chest muscles tight, limit and control your range of motion.
- Keep knees slightly bent, feet flat on the floor and in a staggered step for stability.
- Keep shoulder blades pinched, chest lifted and a slight curve in the lower back.



**START**



**FINISH**

#### START

- Grasp the Hand Grips so the cables lie close to the front of your forearms and palms face forward.
- Stand with one foot forward and one foot back for added stability.
- Stabilize the elbows so they are slightly bent and slightly behind or equal to the shoulders.

#### FINISH

- Slowly move the arms slightly downward and inward, bringing the handles together in front of you at about lower chest height.
- Slowly return to the Start position, keeping tension on the chest throughout the motion.

## Shoulder Exercises

### Rear Deltoid Rows – Shoulder Horizontal Abduction (and elbow flexion)

#### Muscles worked:

Rear and Middle Deltoids; Posterior Rotator Cuff; Upper Latissimus; Teres Major; Trapezius; Rhomboids

#### Bench Position:

Flat Bench Back

#### Accessory:

Long Hand Grips

#### Adjustable Arm Position:

6, 7, or 8

#### Success Tips

- Maintain a 90° angle between your upper arms and torso during motion.
- Keep knees bent and feet on floor.
- To work one arm at a time, place non-working hand on bench to stabilize.
- Keep shoulder blades pinched together and maintain good spinal alignment.

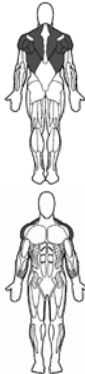

#### START



#### FINISH



#### START

- Sit on the bench facing the main engine.
- Grasp the Hand Grips. Keep palms down and arms straight.
- Sit up straight. Bend slightly forward from hips until arms are in front of body at a 90° angle from torso and in line toward the pulley.
- Lift your chest and keep your shoulder blades together.
- Keep forearms in line with cables.

#### FINISH

- Allowing your arms to bend slowly, move your elbows outwards and backwards, keeping a 70-90° angle between your upper arms and torso.
- Move until your elbows are slightly behind your shoulders, then slowly reverse back to the Start position.
- Keep your shoulder blades tightened throughout motion.

### Standing Lateral Shoulder Raise – Shoulder Abduction (elbow stabilized)

#### Muscles worked:

Middle Deltoids; Upper Trapezius

#### Bench Position:

Remove Bench

#### Accessory:

Long Hand Grips

#### Adjustable Arm Position:

8

#### Success Tips

- Do not swing your arms upward or move your trunk during the motion.
- Keep your feet on floor.



#### START



#### FINISH



#### START

- Remove the bench and stand on the platform, straddling the seat rail and facing the engine.
- Grasp the Hand Grips, palms facing each other.
- Align your spine and bend forward slightly at the hips (15-20°).
- Elevate shoulders slightly toward back of head, keeping spine aligned.

#### FINISH

- Slowly raise your arms out to your sides, at a 90° angle from your body.
- Keep your forearms facing outward throughout the movement.
- Slowly return to the Start position without relaxing muscle tension.

## Shoulder Exercises

### Seated Shoulder Press – Shoulder Adduction (and elbow extension)

#### Muscles worked:

Front Deltoids; Upper Trapezius; Triceps

#### Bench Position:

Flat Bench Back

#### Accessory:

Long Hand Grips

#### Adjustable Arm Position:

7, 8

#### Success Tips

- Keep knees bent and feet on floor.
- Do not increase the arch in your lower back as you raise your arms, but keep your spine steady and tight.
- Keep abdominals tight and maintain good spinal alignment.

#### Variation

Remove the long bench pad and slide the seat toward the engine. Attach the Leg Press Seat Back to the sliding seat, facing away from the engine. (Refer to instructions for attaching the Leg Press Seat Back accessory.) Sit on the seat, and lean against the seat back for added stability.



#### START

- Sit on the bench facing away from the engine.
- Keep your chest up, abs tight and maintain a slight arch in lower back.
- Grasp Hand Grips, palms facing out.
- Raise the Hand Grips to head level so your elbows are equal to shoulder level. Keep your palms facing forward.



#### FINISH

- Straighten your arms slowly over your head, focusing on moving your elbows up and inward toward your ears.
- Slowly return to the Start position, keeping tension in your front shoulder muscles.

### Front Shoulder Raise – Shoulder Flexion (elbow stabilized)

#### Muscles worked:

Front and Middle Deltoids

#### Bench Position:

Flat Bench Back

#### Accessory:

Long Hand Grips

#### Adjustable Arm Position:

8 or 9

#### Success Tips

- Keep abdominals tight and maintain good spinal alignment.
- Keep knees bent and feet on floor.
- Do not increase the arch in your lower back as you raise your arms, but keep your spine steady and tight.



#### START

- Sit on the bench, facing away from the engine.
- Keep your chest up, abs tight and maintain a slight arch in lower back.
- Grasp the Hand Grips, palms facing back, arms straight at your sides.



#### FINISH

- Keeping your arms straight, move them forward, leading with your forearms, until arms are extended in front of you at shoulder height.
- Arms may be moved alternately or together.
- Slowly return to the Start position next to the torso.



## Shoulder Exercises

### Shoulder Extension – (elbows stabilized)

#### Muscles worked:

Latissimus Dorsi; Teres Major; Rear Deltoid; Middle Trapezius; Rhomboids; Triceps



#### Bench Position:

Flat Bench Back

#### Accessory:

Long Hand Grips

#### Adjustable Arm Position:

8 or 9

#### Success Tips

- Keep knees bent and feet flat on floor.
- Keep your lats tightened throughout the motion.
- Keep abdominals tight and maintain good spinal alignment.
- Release your shoulder blades at the end of each rep and initiate new rep by retracting your shoulder blades.



START

#### START

- Sit on the bench facing engine.
- Grasp the Hand Grips, palms facing down, arms straight and at approximately a 45° angle from torso.
- Tighten your trunk muscles to stabilize your spine while maintaining a slight arch in the lower back.



FINISH

#### FINISH

- Initiate movement by pinching shoulder blades together.
- Continue movement by moving your hands in an arc downward, along your sides, until hands are level with hips.
- With controlled movement, slowly return to the Start position.

### Shoulder Shrug – Scapular Elevation

#### Muscles worked:

Upper Trapezius



#### Bench Position:

Removed

#### Accessory:

Hand Grips

#### Adjustable Arm Position:

7 or 8

#### Success Tips

- Keep abdominals tight and maintain good spinal alignment.
- Do not bend your neck or slouch during this exercise.
- Raise shoulders evenly.
- For variation, try this exercise bent forward slightly from the hips.



START

#### START

- Stand on the platform, facing the engine.
- Reach down and grasp the Hand Grips, palms facing each other.
- Let your arms hang at your sides.



FINISH

#### FINISH

- Slowly raise your shoulders towards the back of your head, keeping your neck and head still.
- Slowly reverse back to the Start position, keeping your upper trapezius muscles tight throughout the motion.

## Shoulder Exercises

### Scapular Protraction – (elbows stabilized)

#### Muscles worked:

Serratus Anterior

#### Bench Position:

45° incline

#### Accessory:

Long Hand Grips

#### Adjustable Arm Position:

9

#### Success Tips

- Keep knees bent and feet flat on floor. Lean head back against the bench.
- Keep your spine aligned and a slight arch in your lower back.
- Maintain a 90° angle between upper arms and torso throughout exercise.
- Do not slouch forward or use your arm muscles to assist this motion. Keep this motion only in the shoulder blades

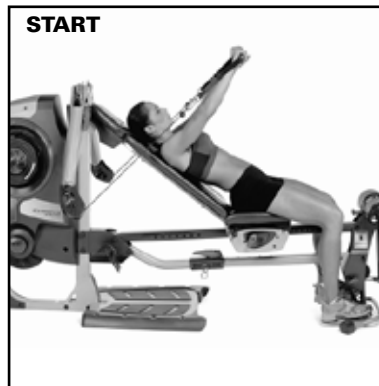

START

#### START

- Reach behind your body, grasp the Hand Grips and straighten your arms in front of you at a 90° angle from torso.
- Keep your arms in line with the cables, palms facing down and wrists straight.

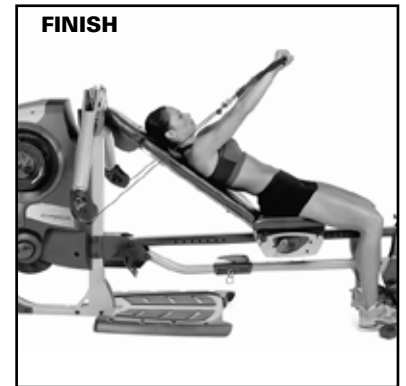

FINISH

#### FINISH

- Keeping your arms straight and in line with the cables, slowly move your shoulder blades forward off the bench, bringing your hands together using only your shoulder muscles.
- Slowly return to the Start position, keeping tension in your shoulder blades.

### Scapular Depression

#### Muscles worked:

Lower Trapezius

#### Bench Position:

Flat Bench Back

#### Accessory:

Long Hand Grips

#### Adjustable Arm Position:

8, 9

#### Success Tips

- Do not lose spinal alignment—keep your chest lifted and head on bench.
- Keep knees bent and feet flat on floor.



START

#### START

- Lie on the bench, head toward the engine.
- Grasp the Hand Grips and bring your arms straight down your sides along your trunk.
- Tighten your trunk muscles to stabilize your spine while maintaining a slight arch in your lower back.



FINISH

#### FINISH

- Keeping your arms straight, slide your shoulder blades downward, toward your hips.
- When your shoulder blades have fully depressed, slowly return to the Start position.

# Shoulder Exercises

## Lying Front Shoulder Raise – Shoulder Flexion (elbows stabilized)

### Muscles worked:

Front and Middle Deltoids

### Bench Position:

Flat Bench Back

### Accessory:

Long Hand Grips

### Adjustable Arm Position:

8

### Success Tips

- Keep knees bent and feet flat on floor.
- Keep abdominals tight and maintain good spinal alignment.
- Do not increase the arch in your lower back while you are lifting your arms.

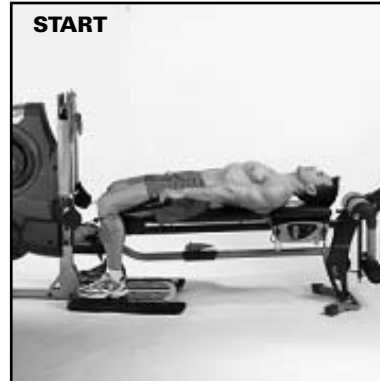

START

### START

- Sit on the bench facing engine.
- Grasp the Hand Grips, palms facing down, arms straight.
- Lie back slowly, supporting your head on the bench.
- Keep your chest lifted, maintaining a slight arch in your lower back.



FINISH

### FINISH

- Keeping your arms straight, move them in an arc upwards until they are directly over your shoulders.
- You may perform this move with both arms simultaneously or one at a time.
- With controlled movement, slowly return to the Start position.

## Reverse Fly Cable Cross – Shoulder Horizontal Abduction (elbows stabilized in slight flexion)

### Muscles worked:

Rear Deltoids; Middle Deltoids;  
Trapezius; Rhomboids

### Bench Position:

Flat Bench Back

### Accessory:

Hand Grips

### Adjustable Arm Position:

8

### Success Tips

- Do not lose spinal alignment—keep your chest lifted.
- Keep knees bent and feet flat on floor.
- Keep your spine aligned and a slight arch in your lower back.
- Maintain a 90° angle between upper arms and torso throughout exercise.



START

### START

- Sit on the Bench facing the engine.
- Grasp the opposite Hand Grips, palms facing each other, arms nearly straight.
- Sit up straight and bend slightly forward from the hips until arms/cables are in front of body at a 90° angle from torso.



FINISH

### FINISH

- Maintaining the bend in your arms, move your arms outward and backward.
- When your elbows are slightly behind your shoulders, slowly return to the Start position, keeping your rear shoulder muscles tightened throughout movement.

## Shoulder Exercises

### Seated Lateral Shoulder Raise — Shoulder Abduction (elbows stabilized)

#### Muscles worked:

Supraspinatus; Middle Deltoids;  
Trapezius

#### Bench Position:

Flat Bench Forward

#### Accessory:

Hand Grips

#### Adjustable Arm Position:

8

#### Success Tips

- Keep knees bent and feet flat on floor.
- Keep abdominals tight and maintain good spinal alignment.
- Do not increase swing arms upward or move trunk during movement.



START



START

- Sit on the bench facing engine.
- Slide the Hand Grips over your forearms, near the elbow.
- Keep your chest lifted, maintaining a slight arch in your lower back.

FINISH



FINISH

- Raise your arms directly out and upward to nearly shoulder level.
- At the top of the movement, you may need to rotate your hands slowly to prevent the cuff from sliding off.
- With controlled movement, slowly return to the Start position.

### Scapular Retraction

#### Muscles worked:

Rhomboids; Trapezius

#### Bench Position:

Flat Bench Back

#### Accessory:

Hand Grips

#### Adjustable Arm Position:

8, 9

#### Success Tips

- Keep knees bent and feet flat on floor.
- Keep your spine aligned, abs tight and a slight arch in your lower back.
- Keep your lats tightened throughout this exercise.
- Release your shoulder blades at the end of each rep. Initiate each new rep by retracting your shoulder blades.



START



START

- Sit on the bench, facing engine.
- Grasp the Hand Grips, palms facing down.
- Brace your heels on the platform, knees bent comfortably, arms straight toward the pulleys.
- Allow your shoulder blades to move forwards, while leaning forward from the hips.

FINISH



FINISH

- Keeping your chest lifted, pinch your shoulder blades backward while keeping your arms straight toward the pulleys.
- Slowly return to the Start position without slouching or changing spinal alignment.

## Shoulder Exercises

### Standing Shoulder Press – Shoulder Abduction (and elbow extension)

#### Muscles worked:

Deltoids; Triceps. Also ankles, knees, hips and core in stabilization.

#### Bench Position:

Removed

#### Accessory:

Long Hand Grips

#### Adjustable Arm Position:

5, 6 or 7

#### Success Tips

- Stabilize body from your feet all the way up through your trunk.
- Keep shoulder muscles tight. Limit and control your range of motion.
- Keep knees slightly bent and feet flat on the floor.
- Keep abdominals tight and maintain good spinal alignment.
- Do not increase the arch in your low back as you raise your arms, but keep your spine stable and tight.



#### START



#### START

- Grasp the Hand Grips so the cables are in line close to the front of your forearms and palms face forward.
- Stand with feet flat on the platform, knees slightly bent.
- Keep chest up, abs tight and maintain a slight arch in the low back.
- Raise the hand grips to head level so your elbows are equal to shoulder level, keeping the palms facing forward.

#### FINISH



#### FINISH

- Straighten your arms slowly over your head, focusing on moving your elbows up and inward toward your ears.
- Slowly return to the Start position, keeping tension on the front shoulder muscles throughout the motion.

### Standing Shoulder Press w/ Alternating Motion – Shoulder Abduction (and elbow extension)

#### Muscles worked:

Deltoids; Triceps. Also ankles, knees, hips and core in stabilization.

#### Bench Position:

Removed

#### Accessory:

Long Hand Grips

#### Adjustable Arm Position:

5, 6 or 7

#### Success Tips

- Stabilize body from your feet all the way up through your trunk.
- Keep shoulder muscles tight. Limit and control your range of motion.
- Keep knees slightly bent and feet flat on the floor.
- Keep abdominals tight and maintain good spinal alignment.
- Do not increase the arch in your low back as you raise your arms, but keep your spine stable and tight.
- Do not allow your body to bend sideways during the motion.



#### START



#### START

- Grasp the Hand Grips so the cables are in line close to the front of your forearms and palms face forward.
- Stand with feet flat on the platform, knees slightly bent.
- Keep chest up, abs tight and maintain a slight arch in the low back.
- Raise one hand grip to head level so your elbow is equal to shoulder level, keeping the palms facing forward, while the other arm is extended upward over your head.

#### FINISH



#### FINISH

- Straighten one arm slowly over your head, focusing on moving your elbow up and inward toward your ear.
- Lower the opposite arm so that your elbow is slightly below or equal to your shoulder.
- Slowly return to the Start position, keeping tension on the front shoulder muscles throughout the motion.

## Shoulder Exercises

### Standing Front Shoulder Raise – Shoulder Flexion

#### Muscles worked:

Deltoids. Also ankles, knees, hips and core in stabilization.

#### Bench Position:

Removed

#### Accessory:

Long Hand Grips

#### Adjustable Arm Position:

7, 8 or 9

#### Success Tips

- Stabilize body from your feet all the way up through your trunk.
- Keep shoulder muscles tight. Limit and control your range of motion.
- Keep knees slightly bent and feet flat on the floor.
- Keep abdominals tight and maintain good spinal alignment.
- Do not increase the arch in your low back as you raise your arms, but keep your spine stable and tight.



#### START



#### START

- Stand on the platform facing away from the engine.
- Grasp the Hand Grips with the palms facing backward.
- Stand with feet flat on the platform, knees slightly bent and arms to your sides.
- Keep chest up, abs tight and maintain a slight arch in the low back.

#### FINISH



#### FINISH

- Keeping your arms straight, move them forward, leading with your forearms, until arms are extended in front of you at shoulder level.
- Arms may be moved together or alternately
- Slowly return to the Start position, keeping tension on the front shoulder muscles throughout the motion.

### Standing Rear Deltoid Row – Shoulder Horizontal Abduction (and elbow flexion)

#### Muscles worked:

Rear and Middle Deltoids; Posterior Rotator Cuff; Upper Lats; Teres Major; Rhomboids; Trapezius. Also ankles, knees, hips and core in stabilization.

#### Bench Position:

Removed

#### Accessory:

Long Hand Grips

#### Adjustable Arm Position:

2 or 3

#### Success Tips

- Stabilize body from your feet all the way up through your trunk.
- Keep shoulder and upper back muscles tight. Limit and control your range of motion.
- Keep knees slightly bent and feet flat on the floor, stagger your foot position for added stability.
- Keep abdominals tight and maintain good spinal alignment.
- Do not increase the arch in your low back as you move your arms, but keep your spine stable and tight.



#### START



#### START

- Grasp the Hand Grips so your palms are facing down and arms are straight.
- Stand with feet flat on the floor, knees slightly bent facing the engine.
- Keep chest up, abs tight, maintain a slight arch in the low back and keep your shoulderblades pinched together.
- Lean back slightly at the hips so that the cables are in line with your arms and shoulders.

#### FINISH



#### FINISH

- Allowing your arms to bend slowly, move your elbows out and backward keeping a 70°-90° angle between your upper arms and your torso.
- Move until your elbows are slightly behind your shoulders.
- Slowly return to the Start position, keeping tension on the shoulderblades.

# Shoulder Exercises

## Standing Cablecross Rear Deltoid Row – Shoulder Horizontal Abduction (and elbow flexion)

### Muscles worked:

Rear and Middle Deltoids; Posterior Rotator Cuff; Upper Lats; Teres Major; Rhomboids; Trapezius. Also ankles, knees, hips and core in stabilization.

### Bench Position:

Removed

### Accessory:

Long Hand Grips

### Adjustable Arm Position:

2 or 3



### START



### FINISH



### START

- Grab the opposite side handles so your palms are facing down and arms are straight.
- Stand with feet flat on the floor, knees slightly bent facing the engine.
- Keep chest up, abs tight, maintain a slight arch in the low back and keep your shoulderblades pinched together.
- Lean back slightly at the hips so the cables are in line with your arms and shoulders.

### FINISH

- Allowing your arms to bend slowly, move your elbows out and backward keeping a 70°-90° angle between your upper arms and your torso.
- Move until your elbows are slightly behind your shoulders.
- Slowly return to the Start position, keeping tension on the shoulder blades.

### Success Tips

- Stabilize body from your feet all the way up through your trunk.
- Keep shoulder and upper back muscles tight, limit and control your range of motion.
- Keep knees slightly bent and feet flat on the floor, stagger your foot position for added stability.
- Keep abdominals tight and maintain good spinal alignment.
- Do not increase the arch in your low back as you move your arms; keep your spine stable and tight.

## Standing Shoulder Extension – Elbow Stabilization

### Muscles worked:

Rear Deltoids; Teres Major; Rhomboids; Middle Trapezius; Triceps. Also ankles, knees, hips and core in stabilization.

### Bench Position:

Removed

### Accessory:

Long Hand Grips

### Adjustable Arm Position:

7, 8 or 9



### START



### FINISH



### START

- Stand on the platform facing the engine
- Grasp the Hand Grips with a Hammer Type grip, arms straight, at approximately a 45° angle in front of the torso.
- Tighten your trunk muscles to stabilize your spine while maintaining a slight arch in the low back.

### FINISH

- Initiate the movement by pinching the shoulderblades together.
- Continue movement by moving your hands in an arc downward, along your sides, until your hands are level with your hips.
- With controlled movement, slowly return to the Start position.

### Success Tips

- Stabilize body from your feet all the way up through your trunk.
- Keep knees slightly bent and feet flat on the floor.
- Keep abdominals tight and maintain good spinal alignment.
- Release your shoulderblades at the end of each rep, and initiate each new rep by retracting your shoulderblades.

## Shoulder Exercises

### Shoulder Internal Rotation w/ Full Shoulder Adduction

#### Muscles worked:

Subscapularis Superior fibers;  
Pectoralis Major

#### Bench Position:

Flat

#### Accessory:

Long Hand Grips

#### Adjustable Arm Position:

5 or 6

#### Success Tips

- Control the motion during the entire exercise. Do not use momentum.
- Do not rotate your spine to gain additional range of motion. Try for pure rotation of your shoulder—more is not better.
- Use light resistance to perform 12-15 perfect repetitions.
- Standing at different angles to the machine will alter the resistance application to the muscle.



#### START



#### START

- Stand off to one side of the machine.
- Grasp the handle with the hand closest to the machine and draw your upper arm into your side.
- Stand up straight with chest lifted, slight arch in the lower back and shoulderblades retracted.
- Distance yourself from the arm of the machine to eliminate slack in the cable\handgrip.

#### FINISH



#### FINISH

- Rotate your forearm towards your abdomen, keeping your elbow at your side during the entire motion.
- Slowly return to the Start position.
- Repeat with the other arm after you have completed the set.

### Shoulder Internal Rotation w/ 90° of Abduction

#### Muscles worked:

Subscapularis Middle\Inferior fibers;  
Pectoralis Major

#### Bench Position:

Removed

#### Accessory:

Long Hand Grips

#### Adjustable Arm Position:

2 or 3

#### Success Tips

- Control the motion during the entire exercise. Do not use momentum.
- Do not rotate your spine to gain additional range of motion. Try for pure rotation of your shoulder—more is not better.
- Moving the arm of the machine to different positions above your shoulder will alter the resistance application to the muscle.



#### START



#### START

- Stand off to one side of the machine.
- Grasp the handle with the hand closest to the machine and position your upper arm 90° away from your side.
- Stand up straight with chest lifted, slight arch in the lower back and shoulderblades retracted.
- Distance yourself from the arm of the machine to eliminate slack in the cable\handgrip.

#### FINISH



#### FINISH

- Rotate your forearm forward then downward, keeping your upper arm stable.
- Do not let your arm move closer toward your side during the motion.
- Slowly return to the Start position.
- Repeat with the other arm after you have completed the set.



# Shoulder Exercises

## Shoulder External Rotation w/ Full Shoulder Adduction

### Muscles worked:

Posterior Deltoid; Teres minor; Infraspinatus

### Bench Position:

Removed

### Accessory:

Long Hand Grips

### Adjustable Arm Position:

5 or 6

### Success Tips

- Control the motion during the entire exercise. Do not use momentum.
- Do not rotate your spine to gain additional range of motion. Try for pure rotation of your shoulder—more is not better.
- Use light resistance to perform 12-15 perfect repetitions.
- Standing at different angles to the machine will alter the resistance application to the muscle.

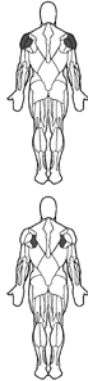

### START



### START

- Stand off to one side of the machine.
- Facing the machine, grasp the handle and position your upper arm at your side.
- Stand up straight with chest lifted, slight arch in the lower back and shoulderblades retracted.
- Distance yourself from the arm of the machine to eliminate slack in the cable/handgrip.

### FINISH



### FINISH

- Rotate your forearm out and back, keeping your upper arm stable.
- Do not let your arm move away your side during the motion.
- Slowly return to the Start position keeping tension on the muscle.
- Repeat with the other arm after you have completed the set.

## Shoulder External Rotation w/ 90° of Abduction

### Muscles worked:

Posterior Deltoid; Teres minor; Infraspinatus

### Bench Position:

Removed

### Accessory:

Long Hand Grips

### Adjustable Arm Position:

4 or 5

### Success Tips

- Control the motion during the entire exercise. Do not use momentum.
- Do not rotate your spine to gain additional range of motion. Try for pure rotation of your shoulder—more is not better.
- Use light resistance to perform 12-15 perfect repetitions.
- Moving the arm of the machine to different positions will alter the resistance application to the muscle.

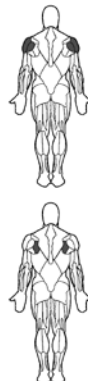

### START



### START

- Stand off to one side of the machine.
- Facing the machine, grab the handle and position your upper arm 90° away from your side.
- Stand up straight with chest lifted, slight arch in the lower back and shoulderblades retracted.
- Distance yourself from the arm of the machine to eliminate slack in the cable/handgrip.

### FINISH



### FINISH

- Rotate your forearm up and away, keeping your upper arm stable.
- Do not let your arm move closer toward your side during the motion.
- Slowly return to the Start position, keeping tension on the muscle.
- Repeat with the other arm after you have completed the set.

## Back Exercises

### Standing Wide Angle Lat Row – Shoulder extension (and elbow flexion)

#### Muscles worked:

Latissimus Dorsi, Rear Deltoids, Biceps Teres Major. Also Hip and core stabilizers.



#### Bench Position:

Removed

#### Accessory:

Long hand grips

#### Adjustable Arm Position:

4 or 5

#### Success Tips

- Do not bend your neck forward or backward.
- Start each rep by retracting your shoulder blades.
- Release your shoulder blades at the end of each rep.
- Keep your spine in alignment and chest lifted.



START



FINISH

#### START

- Stand on the floor facing the engine.
- Grasp the Hand Grips with the arms forward toward the pulleys.
- Keep chest lifted, abs tight and a slight arch in the lower back.

#### FINISH

- Slowly move your elbows back and inward toward your outside edge of the rib cage.
- Slowly extend the arms back to the Start position.
- Keep knees bent and back straight.

### Narrow Pulldowns with Hand Grips – Shoulder Extension (with elbow flexion)

#### Muscles worked:

Latissimus Dorsi; Teres Major; Rear Deltoids; Biceps



#### Bench Position:

Flat Bench Forward

#### Accessory:

Hand Grips

#### Adjustable Arm Position:

0

#### Success Tips

- Keep your chest lifted, abs tight, and a very slight arch in your lower back.
- Keep knees bent and feet flat on platform.
- Keep the lats tightened throughout the entire motion.



START



FINISH

#### START

- Straddle the bench facing the engine, grasp a Hand Grip in each hand, palms facing each other and sit down on the bench.
- Slide back on the bench to get tension on the cables.

#### FINISH

- Keep hands at shoulder width, arms straight. Initiate movement by pulling your shoulderblades back while simultaneously bending your elbows, drawing them down and inward towards your sides.
- At the end of the motion, arms should be near your sides, shoulderblades back, forearms facing upward.
- Slowly return to Start position.

## Back Exercises

### Seated Lat Rows – Shoulder Extension (and elbow flexion)

#### Muscles worked:

Latissimus Dorsi; Teres Major;  
Rear Deltoids; Biceps

#### Bench Position:

Flat Bench Back

#### Accessory:

Hand Grips

#### Adjustable Arm Position:

8, 9 (low lat rows)

1, 2 (high lat rows)

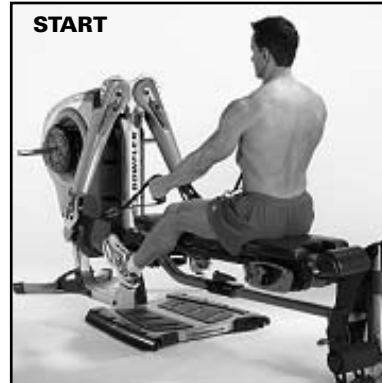

START

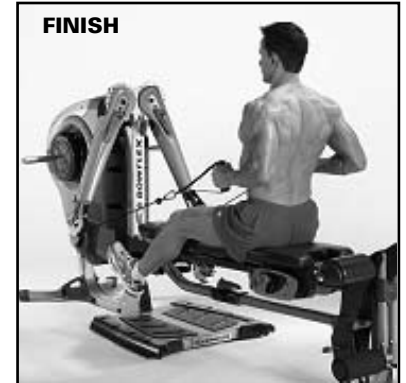

FINISH

#### Success Tips

- Keep knees bent and feet flat on the footrest.
- Do not bend your torso forward.
- Keep your chest lifted and maintain spinal alignment.
- Release your shoulder blades at the end of each rep. Initiate each new rep by pinching your shoulder blades

#### START

- Sit on the bench facing the engine, near the back (leg extension) end of the bench.
- Grasp the Hand Grips, palms facing each other.
- Place your feet on the footrest and bend your knees comfortably.

#### FINISH

- Initiate the movement by pinching your shoulder blades together.
- Pull your upper arms downward and backward, brushing past the sides of the body while keeping your forearms pointing in the direction of the cable.
- Slowly return to the Start position.

### Lying Lat Fly

#### Muscles worked:

Latissimus Dorsi; Teres Major

#### Bench Position:

Flat Back Bench

#### Adjustable Arm Position:

Hand grips, connected at shortened ring.

#### Adjustable Arm Position:

7, 8

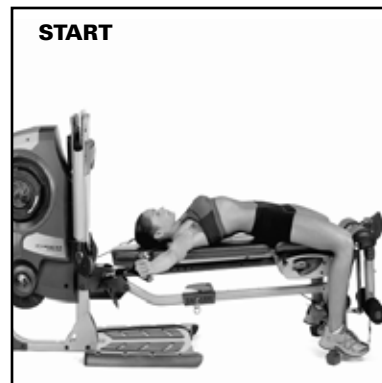

START



FINISH

#### Success Tips

- Keep your lats tightened throughout the entire motion.
- Maintain good spinal alignment, abs tight, slight arch in your lower back.

#### START

- Lie flat on your back on the bench, head toward the engine.
- Position yourself far enough down the bench to grasp the Hand Grips at shoulder level with arms straight out.
- Grasp the Hand Grips, palms facing down.
- Tighten abs to stabilize your spine. Maintain a slight arch in your lower back.

#### FINISH

- Initiate the movement by pulling your shoulder blades down and together while simultaneously drawing your elbows in an arc, towards the sides of your body.
- Slowly return to the Start position allowing your arms and shoulder blades to move fully upward.

## Back Exercises

### Stiff Arm Pulldown

#### Muscles worked:

Latissimus Dorsi

#### Bench Position:

Removed

#### Accessory:

Hand Grips

#### Adjustable Arm Position:

0, 1

#### Success Tips

- Do not lose spinal alignment.
- Keep your lats tightened throughout the entire motion.
- Release your shoulder blades at the end of each rep and initiate each new rep by lowering your shoulder blades.
- Keep your elbows nearly straight (not locked).



START

#### START

- Remove the bench and stand facing the engine straddling the rail.
- Grasp the Hand Grips with your palms down and step back slightly.
- Lift your chest and tighten your abdominals to stabilize your spine while maintaining a very slight arch in your lower back.



FINISH

#### FINISH

- Initiate the movement by lowering your shoulders down and together.
- Keeping your arms straight, continue by slowly moving your hands in an arc toward your legs.
- Slowly return to the Start position without relaxing.

### Standing Lat Row High Pulley

#### Muscles worked:

Latissimus Dorsi; Rear Deltoids; Biceps; Teres Major

#### Bench Position:

Remove seat

#### Accessory:

Hand Grips

#### Adjustable Arm Position:

0, 1

#### Success Tips

- Do not bend your neck forward or backward.
- Release your shoulder blades at the end of each rep.
- Start each rep by retracting your shoulder blades.
- Keep your spine aligned, chest lifted.



START

#### START

- Remove the seat, stand on the floor facing the engine, and grasp the Hand Grips, arms hanging toward pulleys.



FINISH

#### FINISH

- Slowly move your elbows backward, keeping the chest lifted.
- Slowly return the handles to the Start position, keeping knees bent and a slight arch in your lower back
- Stop your arm motion when the elbows reach your sides.

## Back Exercises

### Standing Lat Row Low Pulley – Shoulder Extension (and elbow flexion)

#### Muscles worked:

Latissimus Dorsi; Rear Deltoids; Biceps; Teres Major. Also hip and core stabilizer muscles.



#### Bench Position:

Removed

#### Accessory:

Long Hand Grips

#### Adjustable Arm Position:

8, 9

#### Success Tips

- Do not bend your neck forward or backward.
- Start each rep by retracting your shoulder blades.
- Release your shoulderblades at the end of each rep.
- Keep your spine in alignment and chest lifted.

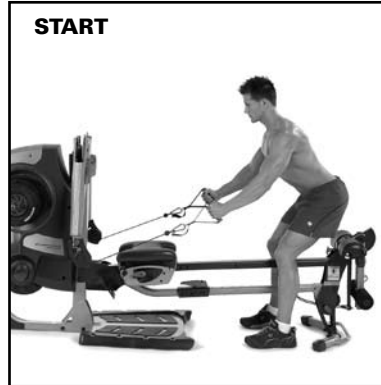

START

#### START

- Stand on the floor facing the engine.
- Grasp the Hand Grips with your arms hanging forward toward the pulleys.
- Bend over to about 45° and keep tension on the cables.



FINISH

#### FINISH

- Slowly move your elbows backward as you bring the hands to a point just below your chest.
- Slowly extend the arms back to the Start position.
- Keep knees bent and back straight.

### Standing Lat Row Alternating Motion-Low Pulley – Shoulder Extension (and elbow flexion)

#### Muscles worked:

Latissimus Dorsi; Rear Deltoids; Biceps; Teres Major. Also hip and core stabilizer muscles.



#### Bench Position:

Removed

#### Accessory:

Long Hand Grips

#### Adjustable Arm Position:

8, 9

#### Success Tips

- Do not bend your neck forward or backward.
- Start each rep by retracting your shoulderblade of the arm moving backward.
- Release your shoulderblades at the end of each rep of the arm going forward.
- Keep your spine in alignment and chest lifted.



START

#### START

- Stand on the floor facing the engine.
- Grasp the Hand Grips with one arm hanging forward toward the pulley, and the other arm back with the elbow bent and forearm in line with the cable.
- Bend over to about 45° and keep tension on the cables



FINISH

#### FINISH

- Slowly move one elbow backward bringing the hand to a point just below your chest, while the other arm moves forward with your hand moving toward the pulley.
- This is an alternating motion, with the arms moving in opposite directions.
- Keep knees bent and back straight.

## Back Exercises

### Standing Single Arm Lat Row Low Pulley — Shoulder Extension

#### Muscles worked:

Latissimus Dorsi; Rear Deltoids; Biceps; Teres Major. Also hip and core rotator muscles.



#### Bench Position:

Removed

#### Accessory:

Long Hand Grips

#### Adjustable Arm Position:

8, 9

#### Success Tips

- Do not bend your neck forward or backward.
- Start each rep by retracting your shoulderblade.
- Release your shoulderblade at the end of each rep.
- Keep your spine in alignment and chest lifted.
- Do not throw the resistance or use momentum to gain more trunk rotation—more is not better.



START



FINISH

#### START

- Stand on one side of the seat rail, facing the engine, with the foot closest to the seat rail forward.
- Grasp the handle with the hand grip away from the seat rail—arm hanging forward toward the pulley.
- Bend over to about 45°, and keep tension on the cables.

#### FINISH

- Slowly move your elbow backward as you bring the hands to a point just below your chest while rotating your trunk in the same direction that you are pulling.
- Slowly extend the arm back to the Start position and rotate your trunk back to the center.
- Keep knees bent and back straight.

### Standing Single Arm/ Single Leg Lat Row Low Pulley — Shoulder Extension

#### Muscles worked:

Latissimus Dorsi; Rear Deltoids; Biceps; Teres Major. Also hip and core rotator muscles, and hip and knee flexor muscles.



#### Bench Position:

Removed

#### Accessory:

Long Hand Grips

#### Adjustable Arm Position:

8, 9

#### Success Tips

- Do not bend your neck forward or backward.
- Start each rep by retracting your shoulderblade.
- Release your shoulderblade at the end of each rep.
- Keep your spine in alignment and chest lifted.
- Do not throw the resistance or use momentum to gain more trunk rotation—more is not better.



START



FINISH

#### START

- Stand on one side of the seat rail facing the engine with the opposite foot forward of the side you are pulling from.
- Grab the handle with the arm hanging forward toward the pulley.
- Bend over to about 45°, keep tension on the cables.

#### FINISH

- Slowly move your elbow backward as you rotate your trunk in the same direction, while flexing your hip/leg forward.
- Slowly extend the arm back to the Start position and counter rotate your trunk back, while extending you hip/leg back.
- Keep knee on the standing leg bent, while keeping the back straight.

## Back Exercises

### Seated Low Back Extension

#### Muscles worked:

Errector Spinae

#### Bench Position:

removed, seated on seat pad

#### Accessory:

Long hand grips

#### Adjustable Arm Position:

8 or 9

#### Success Tips

- Keep knees bent, feet flat on the platform and shoulder blades pinched.
- Keep your spine in alignment, chest lifted, abs tight and a slight arch in your low back.
- Move only from the hips, do not bend at the waist.

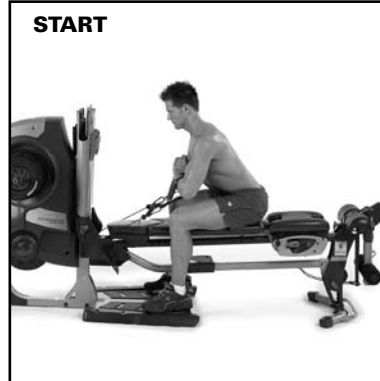

START



FINISH

#### START

- While sitting on the seat pad, move the handles to one side and slide the strap above your forearms near your elbows.
- Cross your arms in front of your chest bringing the handles toward your chest.
- Pinch your shoulder blades together and lean forward from the hips, at least 45°.

#### FINISH

- Keeping your chest lifted, move your entire torso backward by pivoting at the hips.
- Move as far as you can under control.
- Slowly move back to the Start position without slouching or changing spinal alignment.

### Standing Low Back Extension

#### Muscles worked:

Errector Spinae. Also hip, knee and ankle stabilizers.

#### Bench Position:

Removed

#### Accessory:

Long hand grips

#### Adjustable Arm Position:

8 or 9

#### Success Tips

- Keep knees bent, feet flat on the floor and shoulder blades pinched.
- Keep your spine in alignment, chest lifted, abs tight and a slight arch in your low back.
- Move only from the hips, do not bend at the waist.

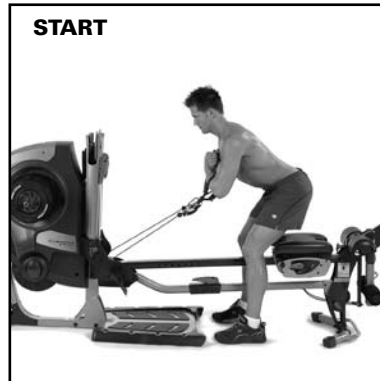

START



FINISH

#### START

- While standing on the floor, move the handles to one side and slide the strap above your forearms near your elbows.
- Cross your arms in front of your chest bringing the handles toward your chest.
- Pinch your shoulder blades together and lean forward from the hips, at least 45°.

#### FINISH

- Keeping your chest lifted and knees slightly bent, move your entire torso upwards by pivoting at the hips. Move as far as you can under control.
- Slowly move back to the Start position without slouching or changing spinal alignment.

## Back Exercises

### Lying Shoulder Pullover

#### Muscles worked:

Latissimus Dorsi; Teres Major; Deltoids; Triceps; Chest

#### Bench Position:

Flat

#### Accessory:

Long Hand Grips

#### Adjustable Arm Position:

8, 9

#### Success Tips

- Release your shoulderblades at the end of each repetition and initiate each new rep by depressing your shoulderblades.
- Keep your spine in alignment, chest lifted, abs tight and a slight arch in your low back.
- Keep the lats tight throughout the motion.



START

#### START

- With the bench flat, lie on your back with your head facing the engine.
- Position yourself far enough down the bench to allow the arms to extend overhead.
- Keep knees bent and feet on or near the floor.



FINISH

#### FINISH

- Move both arms in a arc upward and then down toward your legs.
- Keep shoulderblades on the bench and slide them toward your hips as you move your arms.
- Control the return motion to the Start position by slowly moving the arms overhead and releasing the shoulderblades.

### Reverse Grip Lat Pulldown – Shoulder extension with elbow flexion

#### Muscles worked:

Latissimus Dorsi, Teres Major, Rear Deltoids and Biceps

#### Bench Position:

Flat

#### Accessory:

Long hand grips

#### Adjustable Arm Position:

0 or 1

#### Success Tips

- Keep chest lifted, abs tight and a very slight arch in your lower back.
- Keep knees bent and feet flat on the floor.
- Keep the lats tight throughout the motion.



START

#### START

- Straddle the bench facing the engine, grab the hand grips with the palms facing upward and sit down on the bench.
- Slide back on the bench to get tension on the cable.



FINISH

#### FINISH

- Keep hands at shoulder width, arms straight.
- Initiate the movement by pulling your shoulder blades back while bending your elbows, drawing them down and in toward your sides.
- At the end of the motion, arms should be near your sides, shoulders blades back and palms facing up.
- Slowly return to the Start position.



## Back Exercises

### Wide Pulldowns – Shoulder Adduction (with elbow flexion)

#### Muscles worked:

Latissimus Dorsi; Teres Major;  
Rear Deltoids; Biceps

#### Bench Position:

Flat Bench Forward

#### Accessory:

Hand Grips

#### Adjustable Arm Position:

1, 2

#### Success Tips

- Keep knees bent and feet flat on floor.
- To determine the appropriate grip width for you, hold your arms straight out to your sides at shoulder height. Bend your elbows approximately 90°. Hands should be no wider apart than your elbows (beginners may narrow their grip to increase comfort).
- Keep your spine aligned, abs tight and a slight arch in your lower back.

#### Variation

Remove the long bench pad. Attach the Leg Press Seat Back to the sliding seat, facing away from the engine. (Refer to instructions for attaching the Leg Press Seat Back accessory.) Lock the seat in position at the far end of the seat rail. After grasping the Hand Grips, sit on the seat, facing the engine. Lean forward at the hip, and use the seat back for added stability.

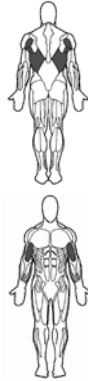

#### START

- Grasp the Hand Grips using the wide grip determined by following the directions in the Success Tips, then sit on the bench, facing the engine.
- Lean forward at the hip.
- Arms should be in line with the pulley.



#### FINISH

- Initiate movement by depressing the shoulder blades while simultaneously drawing elbows down and inward toward your sides.
- Hand grips may not touch your chest. At the end of the motion, arms should be near your sides, shoulder blades fully depressed.
- Keep forearms facing upward.
- Slowly return to Start position.

## Arm Exercises

### Triceps Pushdown – Elbow Extension

#### Muscles worked:

Triceps

#### Bench Position:

Removed

#### Accessory:

Hand Grips

#### Adjustable Arm Position:

0, 1

#### Success Tips

- Keep your upper arms motionless and your wrists straight.
- Keep your chest lifted, abs tight and maintain a slight arch in lower back.
- Tighten the triceps throughout the exercise, using controlled motion.



**START**

#### START

- Straddle the Seat Rail, facing the engine.
- Grasp the Hand Grips, palms facing down.
- Bring hands in front of you, keeping hand grips approximately at rib level.



**FINISH**

#### FINISH

- Keeping your upper arms stationary, elbows next to trunk, slowly push your arms downward in a gentle arc until hands are near tops of your thighs.
- Keeping your triceps tightened, slowly reverse the arcing motion.

### French Press – Elbow Extension overhead

#### Muscles worked:

Triceps

#### Bench Position:

Flat Bench Back

#### Accessory:

Hand Grips

#### Adjustable Arm Position:

9

#### Success Tips

- Keep your upper arms motionless and your wrists straight.
- Keep your chest lifted and maintain spinal alignment, keeping a very slight arch in your lower back.
- Tighten the triceps throughout the exercise, using controlled motion.



**START**

#### START

- Sit on the bench facing away from the engine, keeping knees bent and feet flat on the platform.
- Reach behind and grasp one or both of the Hand Grips, using a hammer style grip.
- Draw arms up until elbows are pointing forward, hands behind head.



**FINISH**

#### FINISH

- Keeping your upper arms stationary, straighten your elbows, bringing your hands overhead.
- Extend your elbows until your arms are completely straight, and then reverse your motion, slowly returning to the Start position without relaxing muscle tension.

## Arm Exercises

### Standing French Press – Elbow extension from a shoulder flexed position

#### Muscles worked:

Triceps. Also ankles, knees, hips, shoulders & core in stabilization.

#### Bench Position:

Removed

#### Accessory:

Long hand grips

#### Adjustable Arm Position:

8 or 9

#### Success Tips

- Stabilize body from your feet all the way up through your trunk.
- Keep knees slightly bent, feet flat on the floor and in a staggered step for stability.
- Keep abs tight, chest lifted and a slight curve in the lower back.
- Stabilize the shoulder and wrist, only allowing the elbow joint to be involved in the motion.



#### START



#### START

- Stand facing away from the engine with one foot forward and one foot back for added stability.
- Reach overhead and grasp the Hand Grips with your palms facing each other in a hammer style grip, elbows bent and pointing forward, hands behind the shoulders.
- Keep your elbows in line with the cables throughout the movement and wrists straight.

#### FINISH



#### FINISH

- Keeping the upper arms stationary, straighten your elbows, bringing your hands overhead.
- Stop your motion before your elbows are completely straight, reverse the motion, slowly returning to the Start position maintaining tension on the muscle.

### Lying Triceps Press – Elbow extension

#### Muscles worked:

Triceps

#### Bench Position:

Flat

#### Accessory:

Long hand grips

#### Adjustable Arm Position:

8 or 9

#### Success Tips

- Keep knees bent, feet on or near the floor.
- Keep abs tight, chest lifted and a slight curve in the lower back.
- Stabilize the shoulder and wrist, only allowing the elbow joint to be involved in the motion.



#### START



#### START

- Lie flat on the bench head toward the engine, keep knees bent, feet flat on or near the floor.
- Reach overhead and grasp the Hand Grips with your palms facing each other in a hammer style grip, elbows bent and upper arms next to your sides.
- Keep your elbows in line with the cables throughout the movement and wrists straight.

#### FINISH



#### FINISH

- Keeping the upper arms stationary, straighten your elbows, bringing your hands down toward your sides.
- Extend your elbows completely straight, reverse the motion, slowly returning to the Start position maintaining tension on the muscle.

## Arm Exercises

### Lying 45° Triceps Extension – Elbow Extension

#### Muscles worked:

Triceps

#### Bench Position:

Flat Bench Back

#### Accessory:

Hand Grips

#### Adjustable Arm Position:

9

#### Success Tips

- Keep your upper arms motionless and your wrists straight throughout the entire exercise.
- Keep your chest lifted, spine aligned, and a slight arch in your lower back.
- Tighten the triceps throughout the exercise, using controlled motion.

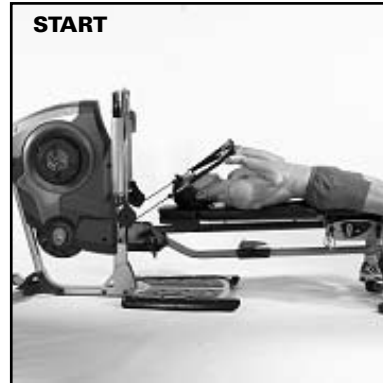

START

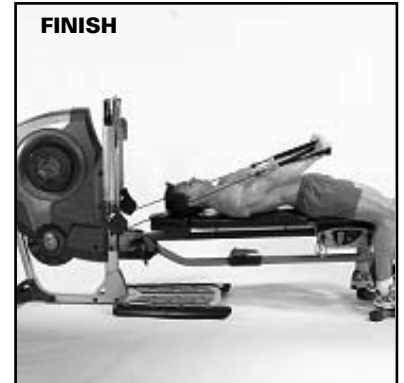

FINISH

#### START

- Lie flat on the Bench, head toward the engine. Keep your knees bent and your feet on or near the floor.
- Reach overhead and grasp the Hand Grips, palms facing up.
- Keep your elbows bent, bringing your upper arms to the front, at approximately a 45° angle from the front of your torso.

#### FINISH

- Keeping your upper arms stationary and next to your torso, straighten your arms in an arcing motion upward then down toward your legs.
- Fully straighten your arms and then, with a controlled motion, slowly bring your arms back to the Start position without moving your upper arms.

### Cross Triceps Extension

#### Muscles worked:

Triceps

#### Bench Position:

45° incline

#### Accessory:

Hand Grips

#### Adjustable Arm Position:

7 or 8

#### Success Tips

- Keep your upper arm motionless and your wrists straight.
- Keep your chest lifted, pinch your shoulder blades together and maintain a slight arch in lower back.
- Tighten the triceps throughout the exercise, using controlled motion.



START



FINISH

#### START

- Sit facing away from the engine.
- Reach one hand over the opposite shoulder (right hand over left and vice versa) and grasp a Hand Grip using a hammer style grip. Bend your elbow until your hand is above your chest.
- With your free hand, stabilize the active hand at the elbow.

#### FINISH

- Keeping your upper arm stationary, straighten your arm outward, using an arcing motion
- Fully extend the elbow.
- Keeping your triceps tightened, slowly reverse the arcing motion and bring your arm back to the Start position.

# Arm Exercises

## Rope Pushdowns – Elbow extension

### Muscles worked:

Triceps

### Bench Position:

Removed

### Accessory:

Long hand grips

### Adjustable Arm Position:

0 or 1

### Success Tips

- Keep knees slightly bent, feet flat on the platform.
- Keep abs tight, chest lifted and a slight curve in the lower back.
- Stabilize the shoulder and wrist, only allowing the elbow joint to be involved in the motion.



START



FINISH

### START

- Cross your arms and grasp the Hand Grips (right hand on left handle, left hand on right handle) palms facing slightly down with a hammer style grip.
- Bring hands toward each other, in front of you, until they are positioned as if your holding a rope.
- Keep your elbows bent, upper arms at your sides.

### FINISH

- Keeping the upper arms stationary, straighten your elbows, bringing your hands down and back.
- Extend your elbows completely straight, reverse the motion, slowly returning to the Start position maintaining tension on the muscle.

## Standing Hammer Grip Curls – Elbow flexion neutral

### Muscles worked:

Biceps, Brachialis, Brachioradialis

### Bench Position:

Removed

### Accessory:

Long hand grips

### Adjustable Arm Position:

8 or 9

### Success Tips

- Keep knees slightly bent, feet flat on the platform.
- Keep abs tight, chest lifted and a slight curve in the lower back.
- Stabilize the shoulder and wrist, only allowing the elbow joint to be involved in the motion.



START



FINISH

### START

- Reach down and grasp the Hand Grips with a hammer style grip.
- Press your upper arms into your sides.

### FINISH

- Keeping the upper arms stationary and elbows at your sides, Slowly curl the handles forward then upward toward the shoulders.
- Slowly reverse the arcing motion, bringing your hands back to the Start position.

## Arm Exercises

### Standing Biceps Curl – Elbow flexion from a shoulder extended position

#### Muscles worked:

Biceps

#### Bench Position:

Removed

#### Accessory:

Long hand grips

#### Adjustable Arm Position:

8 or 9

#### Success Tips

- Stand in front of the platform facing away from the engine with a staggered step for more stability, (the back foot may be on the platform).
- Keep abs tight, chest lifted and a slight curve in the lower back.
- Stabilize the shoulder and wrist, only allowing the elbow joint to be involved in the motion.



#### START



#### START

- Reach back and grasp the Hand Grips with your arm extended backward.
- Do not let your arm go completely straight, maintain tension on the biceps.

#### FINISH



#### FINISH

- Keep the upper arms stationary and elbows back.
- Slowly curl the handles forward then upward toward the shoulders.
- Only curl forward until the cable comes close, but not touching your forearm.
- Slowly reverse the arcing motion, bringing your hands back to the Start position.

### Standing Biceps Curl – Elbow flexion from a shoulder flexed position

#### Muscles worked:

Biceps

#### Bench Position:

Removed

#### Accessory:

Long hand grips

#### Adjustable Arm Position:

2 or 3

#### Success Tips

- Stand in front of the platform facing the engine with a staggered step for more stability.
- Keep abs tight, chest lifted and a slight curve in the lower back.
- Stabilize the shoulder and wrist, only allowing the elbow joint to be involved in the motion.



#### START



#### START

- Reach up and grasp the Hand Grips with your arm extended forward.
- Do not let your arm go completely straight, maintain tension on the biceps.

#### FINISH



#### FINISH

- Keep the upper arms stationary, slowly curl the handles up then inward toward the shoulders.
- Fully shorten the biceps by squeezing the forearm toward the upper arm.
- Slowly reverse the arcing motion, bringing your hands back to the Start position.

## Arm Exercises

### Standing Biceps Curl – Elbow Flexion (in supination)

#### Muscles worked:

Biceps; Brachialis; Brachioradialis

#### Bench Position:

Removed

#### Accessory:

Hand Grips

#### Adjustable Arm Position:

8, 9

#### Success Tips

- Keep your chest lifted, abs tight and a very slight arch in your lower back.
- Keep your elbows at your sides and your wrists straight.



**START**



**FINISH**

#### START

- Straddle the Seat Rail, facing the engine.
- Reach down and grasp the Hand Grips, palms facing forward.
- Straighten, with your arms slightly bent, keeping tension on the biceps.

#### FINISH

- Keeping your upper arms stationary and your elbows at your sides, slowly curl the Hand Grips forward, then upward and in towards your shoulders.
- Slowly reverse the arcing motion bringing your hands back to the Start position.

### Seated Biceps Curl – Flexion (in supination)

#### Muscles worked:

Bicep; Brachialis; Brachioradialiss

#### Bench Position:

Flat Bench Back

#### Accessory:

Hand Grips

#### Adjustable Arm Position:

8

#### Success Tips

- Keep your upper body motionless and your wrists straight.
- Keep your chest lifted, trunk muscles tight and maintain a slight arch in lower back.
- Keep your spine aligned throughout movement



**START**



**FINISH**

#### START

- Sit on the bench, facing the engine. Keep one foot flat on the floor, and bend the other leg, bringing your foot up onto the bench, knee slightly turned outward.
- With the arm on the same side as your lifted leg, reach forward and grasp a Hand Grip, keeping your elbow bent. Allow your upper arm (not elbow) to rest on the elevated knee.

#### FINISH

- Slowly curl your forearm up toward your shoulder, keeping the upper arm completely still.
- Keeping your biceps tightened, slowly reverse the curling motion and bring your arm back to the Start position.

## Arm Exercises

### Preacher Curl – Elbow Flexion (in supination)

#### Muscles worked:

Biceps; Brachialis; Brachioradialis

#### Bench Position:

Seat

#### Accessory:

Preacher Curl Attachment, Curl Bar;  
Leg Press Seat Back (optional)

#### Adjustable Arm Position:

9

#### Success Tips

- Keep wrists straight.
- Keep chest lifted, abs tight and maintain a very slight arch in your lower back.
- For additional stability, rest your back against the Leg Press Seat Back.



START



START

- Sit at the end of the bench facing away from the engine.
- Rest your elbows on the platform and grasp the inner handles of the ab/leg attachment with an underhand grip.
- Your knees should be bent and feet flat on the floor.
- Keep tension on the muscle and do not let the arm go straight.

FINISH



FINISH

- Slowly curl the handles in an arc toward your head while keeping your elbows and upper arms completely still.
- Slowly lower to the Start position.

For information on how to attach the Preacher Curl Attachment and cables, and Leg Press Seat Back, please see the earlier section in this manual (or the corresponding section in the Assembly Manual) on how to install attachments.

### Reverse Grip Tricep Pushdown

#### Muscles worked:

Triceps

#### Bench Position:

Removed

#### Accessory:

Short Hand Grips

#### Adjustable Arm Position:

8

#### Success Tips

- Keep your upper arms motionless
- Keep your wrists straight.
- Tighten your triceps throughout the exercise and control the motion on the way back.



START



START

- Stand on the platform facing the engine.
- Grasp the short hand grips with an underhand grip at shoulder width.
- Bring your arms straight down to your sides.

FINISH



FINISH

- Keeping your upper arms stationary, elbows in a fixed position, bend your elbows moving your hands in an arcing motion towards your shoulders.
- Stop your motion when your hands are above your elbows, then slowly reverse your arcing motion until your elbows are straight.



# Arm Exercises

## Tricep Kickback

### Muscles worked:

Triceps

### Bench Position:

Flat Back Bench

### Accessory:

Hand Grips

### Adjustable Arm Position:

8 or 9

### Success Tips

- Maintain good spinal alignment.
- Keep your arm at your side and your wrist straight throughout entire motion.
- Tighten the triceps throughout the exercise and control the returning motion.



START



FINISH

### START

- Straddle the bench facing the engine, bend forward at your hips until your torso is parallel to the bench, slightly arching your back.
- Support yourself with one arm on the bench and grasp a handle using a hammer style grip with your free hand.
- Draw your elbow back so that the upper arm is by your side, parallel to the bench, and your elbow bent about 90°.

### FINISH

- Completely straighten your elbow while keeping your upper arm completely still.
- Slowly return to the Start position.
- Repeat with the other arm on the other side of the machine after completing a set.

## Reverse Curl – Elbow Flexion (in pronation)

### Muscles worked:

Brachialis; Brachioradialis; Biceps

### Bench Position:

Removed

### Accessory:

Hand Grips

### Adjustable Arm Position:

8, 9

### Success Tips

- Keep your upper body motionless, elbows at your sides and your wrists straight.
- Keep your trunk muscles tight and maintain a slight arch in lower back.



START



FINISH

### START

- Straddle the Seat Rail, facing the engine.
- Reach down and grasp the Hand Grips, palms facing backward.
- Straighten, keeping your upper arms and elbows by your sides.
- Keep tension on the muscle and do not fully extend the elbow.

### FINISH

- Keeping your palms facing down, use your forearms to slowly bend your elbows, curling the Hand Grips forward, then upward and in towards your shoulders.
- Keep your elbows at your sides and your upper arms completely still.
- Slowly reverse the curling motion and bring your arms back to Start position.

## Arm Exercises

### Lying Biceps Curl – Elbow Flexion (in supination)

#### Muscles worked:

Biceps; Brachialis; Brachioradialis

#### Bench Position:

Flat Bench Forward

#### Accessory:

Hand Grips

#### Adjustable Arm Position:

8

#### Success Tips

- Keep your upper arms motionless and your wrists straight throughout the entire exercise.
- Keep your chest lifted, spine straight, and a slight arch in your lower back.



START

- START**
- Sit on the bench, facing the engine. Keep your knees bent and feet flat on the platform.
  - Grasp the Hand Grips with your palms up and arms slightly bent, keeping tension on the muscle.
  - Lie back completely with your head supported by the bench.



FINISH

- FINISH**
- Curl the Hand Grip forward and up, toward your shoulder, making sure to keep your upper arm completely motionless and your elbows at your sides.
  - Slowly bring your arm back to the Start position, maintaining the same arc of motion.

### Seated Wrist Extension

#### Muscles worked:

Extensor Carpi Ulnaris;  
Extensor Digitorum

#### Bench Position:

Flat Bench Back

#### Accessory:

Hand Grips

#### Adjustable Arm Position:

9

#### Success Tips

- Move slowly and keep tension in the back of the forearms at all times.
- Keep your chest lifted, trunk muscles tightened, and a very slight arch in your lower back.
- You may perform this exercise one arm at a time to make it easier to focus and isolate the back of your forearms, or with both arms simultaneously to save time.



START

- START**
- Sit facing the engine with your knees bent, feet together and flat on the bench. Sit far back enough on the bench to maintain muscle and cable tension throughout exercise.
  - Grasp the Hand Grips, palm facing down, and rest your mid-forearms on your lower thighs, keeping your elbows flared slightly to the sides.



FINISH

- FINISH**
- Slowly curl the back of your fists backward towards your forearms.
  - Move the wrist to full extension.
  - Slowly return to the Start position.

## Arm Exercises

### Standing Wrist Curls – Wrist flexion from elbow flexed position

#### Muscles worked:

Biceps, Flexor Digitorum, Flexor Carpi Radialis

#### Bench Position:

Removed

#### Accessory:

Long hand grips

#### Adjustable Arm Position:

8 or 9

#### Success Tips

- Stand on the platform facing the engine.
- Keep abs tight, chest lifted and a slight curve in the lower back.
- Stabilize the shoulder and elbow, only allowing the wrist joint to be involved in the motion.



START



FINISH

#### START

- Reach down and grasp the Hand Grips, palms facing up, then position your upper arms against your sides.
- Bend your elbow to approximately 90° and keep it there throughout the exercise.

#### FINISH

- Keep the shoulder and elbow stationary, slowly curl your fists up then inward toward the forearms.
- Slowly reverse the arcing motion, bringing your hands back to the Start position.

### Standing Wrist Extension – Wrist extension from an elbow flexed position

#### Muscles worked:

Extensor Digitorum, Extensor Carpi Ulnaris

#### Bench Position:

Removed

#### Accessory:

Long hand grips

#### Adjustable Arm Position:

8 or 9

#### Success Tips

- Stand on the platform facing the engine.
- Keep abs tight, chest lifted and a slight curve in the lower back.
- Stabilize the shoulder and elbow, only allowing the wrist joint to be involved in the motion.



START



FINISH

#### START

- Reach down and grasp the Hand Grips, palms facing down, then position your upper arms against your sides.
- Bend your elbow to approximately 90° and keep it there throughout the exercise.

#### FINISH

- Keep the shoulder and elbow stationary, slowly curl your fists up then inward toward the forearms.
- Slowly reverse the arcing motion, bringing your hands back to the Start position.

# Arm Exercises

## Seated Wrist Curl – Wrist Flexion

### Muscles worked:

Flexor Digitorum;  
Flexor Carpi Radialis

### Bench Position:

Flat Bench Back

### Accessory:

Hand Grips

### Adjustable Arm Position:

9

### Success Tips

- Move slowly, keeping tension in the front of the forearms at all times.
- Keep your chest lifted, trunk muscles tightened, and a slight arch in your lower back.
- You can perform this exercise one arm at a time to make it easier to focus and isolate the front of your forearms, or you can perform it with both arms simultaneously to save time.



### START

- Sit facing the engine with your knees bent, feet together and flat on the bench. Sit far back enough on the bench to maintain muscle and cable tension throughout exercise.
- Grasp the Hand Grips, palm facing up, and rest your mid-forearms on your lower thighs, allowing the wrists to bend downward.



### FINISH

- Slowly curl your fists towards the front of your forearms.
- Return to the Start position slowly, without relaxing the muscle tension in your wrists.

# Abdominal Exercises

## Standing Trunk Rotation

### Muscles worked:

Rectus Abdominus, Obliques, Spinal Erectors and Serratus Anterior

### Bench Position:

Removed

### Accessory:

Long hand grips

### Adjustable Arm Position:

4 or 5

### Success Tips

- Keep your knees slightly bent and feet flat on the floor.
- This exercise must be performed correctly, failure to do so could result in injury (use a light resistance).
- Keep all motion in your torso.
- Move only as far as your muscles will take you. Do not use momentum to increase your range of motion.



### START



### START

- Stand with one side toward the engine, angled about 45° away from the platform.
- Grab the handle closest to you with both hands.
- Raise your arms up near shoulder height, arms extended toward the leg closest to the engine.
- Keep the elbows slightly bent.

### FINISH



### FINISH

- Tighten the entire abdominal area and slowly rotate your rib cage and arms away from the engine 30-40 degrees, as if you were rotating with a rod through the middle of your spine.
- Slowly reverse the motion, returning to the Start position without losing muscle tension.

## Standing Oblique Crunch

### Muscles worked:

Rectus Abdominus, Obliques

### Bench Position:

Removed

### Accessory:

Long hand grips

### Adjustable Arm Position:

0 or 1

### Success Tips

- Keep your knees slightly bent and feet flat on the platform.
- This exercise must be performed correctly, failure to do so could result in injury (use a light resistance).
- Keep all motion in your torso.
- Move only as far as your muscles will take you. Do not use momentum to increase your range of motion.



### START



### START

- Stand on one side, straddling the seat rail, facing away from the engine.
- Grasp one Hand Grip, reaching over the opposite shoulder, and position the webbing over the shoulder as shown.

### FINISH



### FINISH

- Tighten your ab muscles on the side with the active arm, focusing on the side of your ribs toward the front of your pelvis.
- Slowly move diagonally, rotating your torso away from the side holding the hand grip.
- Crunch as deeply as you can, keeping the hips stable. Do not lean forward at the hips.
- Slowly reverse the motion, returning to the Start position without losing muscle tension.

## Abdominal Exercises

### Kneeling "Wood Chop" – High to Low Trunk flexion with rotation

#### Muscles worked:

Rectus Abdominus, Obliques, and Serratus Anterior

#### Bench Position:

Removed

#### Accessory:

Long hand grips

#### Adjustable Arm Position:

0 or 1

#### Success Tips

- This exercise must be performed correctly, failure to do so could result in injury (use a light resistance).
- Keep all motion in your torso.
- Move only as far as your muscles will take you. Do not use momentum to increase your range of motion.



#### START



#### START

- Stand off to one side of the platform and kneel down on the knee closest to the engine angled about 45° away from the platform.
- Raise your arms above your head and grab the handle closest to you with both hands.
- Arms extended toward the pulley.
- Keep the elbows slightly bent.

#### FINISH



#### FINISH

- Tighten the entire abdominal area and slowly rotate your rib cage and arms away from the pulley toward your opposite knee.
- Slowly reverse the motion, returning to the Start position without losing muscle tension.

### Kneeling Low to High Trunk Rotation

#### Muscles worked:

Rectus Abdominus, Obliques, Spinal Erectors and Serratus Anterior

#### Bench Position:

Removed

#### Accessory:

Long hand grips

#### Adjustable Arm Position:

9

#### Success Tips

- This exercise must be performed correctly, failure to do so could result in injury (use a light resistance).
- Keep all motion in your torso.
- Move only as far as your muscles will take you. Do not use momentum to increase your range of motion.



#### START



#### START

- Stand off to one side of the platform and kneel down on the knee closest to the engine angled about 45° away from the platform.
- Reach across and down, grab the handle closest to you with both hands.
- Arms extended toward the pulley.
- Keep the elbows slightly bent.

#### FINISH



#### FINISH

- Tighten the entire abdominal area and slowly rotate your rib cage and arms up and away from the pulley toward your opposite knee and slightly above your head.
- Slowly reverse the motion, returning to the Start position without losing muscle tension.

# Abdominal Exercises

## Reverse Crunch – Spinal Flexion

### Muscles worked:

Rectus Abdominus; Obliques

### Bench Position:

Flat Bench Back

### Accessory:

None

### Adjustable Arm Position:

None

### Success Tips

- Keep your upper body, knees and hips stationary. Relax your neck.
- Tighten your abs before you move.
- Allow exhalation up and inhalation down without exaggerating breathing.
- Contract as far into the movement as possible. Lower under control. Keep abs tight during entire motion.



START



FINISH

### START

- Lie on the bench, head toward the engine, grasp bench for support.
- Bend your hips and knees until your legs are in a “seated” position as shown above—knees and hips at 90° angles.
- If maintaining this position is difficult, move your knees toward your chest and maintain that position for the duration of this exercise. As you strengthen, this position will become easier.

### FINISH

- Tighten your abs, and then slowly curl your hips toward your rib cage. Move as far as you can without using your legs to get momentum.
- Do not curl up onto your shoulder blades.
- Slowly reverse the motion, returning to the Start position without relaxing.

## Trunk Rotation

### Muscles worked:

Rectus Abdominus; Obliques;  
Transverse Abdominus

### Bench Position:

Flat Bench Back

### Accessory:

Handgrips

### Adjustable Arm Position:

5 or 6

### Success Tips

- Keep chest lifted, shoulders pinched, abs tight and slight arch in lower back.
- This exercise must be performed correctly—failure to do so could result in injury. Use only low resistance.
- Keep all motion in your torso.
- Move only as far as your muscles will take you—do not use momentum to increase your range of motion



START



FINISH

### START

- Sit sideways on the bench, one side toward the engine. Grasp Hand Grip closest to you with both hands.
- Raise both arms up near shoulder level, hands extended over the leg closest to the engine.
- Keep your elbows slightly bent.

### FINISH

- Tighten your entire abdominal area and slowly rotate your rib cage and arms away from the engine 30-40°, as if you were rotating with a rod through the middle of your spine.
- Slowly reverse the motion, returning to the Start position without relaxing muscle tension.

## Abdominal Exercises

### Seated (Resisted) Abdominal Crunch – Spinal Flexion

#### Muscles worked:

Rectus Abdominus; Obliques

#### Bench Position:

45° incline

#### Accessory:

Hand Grips

#### Adjustable Arm Position:

8

#### Success Tips

- Do not lift your head or chin—your head should follow the rib motion rather than lead it. Maintain normal neck posture.
- Tighten your abs throughout the entire exercise, relaxing only at the end of each set.
- Move slowly to eliminate momentum.
- Allow exhalation down and inhalation up without exaggerating breathing.



#### START

- Grasp the Hand Grips in both hands, drawing them over your shoulders. Rest the back of your fists on your chest or shoulders, palms facing up.
- Lower back can start out flat or in a normal arch, knees and hips are bent and feet should be flat on the floor.



#### FINISH

#### FINISH

- Tighten your abs and curl only your torso, slowly moving your ribs toward your hips. Move as far as you can without moving your hips or neck.
- Do not allow your lower back to lose contact with the bench during this entire exercise.
- Slowly reverse the motion, returning to the Start position without relaxing your abs.

### Seated (Resisted) Oblique Abdominal Crunch – Spinal Oblique Flexion

#### Muscles worked:

Rectus Abdominus; Obliques

#### Bench Position:

45° incline

#### Accessory:

Hand Grips

#### Adjustable Arm Position:

7

#### Success Tips

- Do not lift your head or chin—your head should follow the rib motion rather than lead it. Maintain normal neck posture.
- Tighten your abs throughout the entire exercise, relaxing only at the end of each set.
- Move slowly to eliminate momentum.
- Allow exhalation down and inhalation up without exaggerating breathing.



#### START

- Cross one arm over the opposite shoulder, grasp a Hand Grip, and rest the hand on your shoulder or chest, palm facing down.
- Lower back can start out flat or in a normal arch, knees and hips are bent and feet should be flat on the floor.

#### START



#### FINISH

#### FINISH

- Tighten your abs on the side with the active arm, focusing on the side of your ribs to the front of your pelvis on that side.
- Slowly move diagonally, rotating torso away from the side holding the Hand Grip, ribs turned toward the front of your pelvis.
- Crunch as deeply as you can, keeping lower back on bench.
- Slowly reverse to the Start position without resting.



# Leg Exercises

## Leg Extension

### Muscles worked:

Quadriceps

### Bench Position:

Leg Extension Seat

### Accessory:

Leg Extension (refer to instructions for hooking up the cables for leg exercises);  
Leg Press Seat Back (optional)

### Adjustable Arm Position:

9



### Success Tips

- Use slow, controlled motion—do not “kick” into the extension.
- Do not let your knees rotate outward during the exercise. Keep kneecaps pointing up and straight forward.
- For additional stability, rest your back against the Leg Press Seat Back. (Refer to instructions for attaching the Leg Press Seat Back accessory.)

### START

- Sit on the Leg Extension Seat with your knees near the pivot point and the lower roller pads in front of your shins (see Start image above).
- Adjust your thighs to hip-width, pointing your knee caps forward.
- Grasp the sides of the seat to stabilize yourself.
- Sit up straight, chest lifted, abs tight and a slight arch in your lower back.

### FINISH

- Tighten your quads and slowly straighten your legs, moving your feet forward then upward until your legs are completely straight and your kneecaps point upward to the ceiling.
- Slowly reverse the motion, returning to the Start position without relaxing your quads.

## Prone (Lying face down) Leg Curls

### Muscles worked:

Hamstrings

### Bench Position:

Flat with leg curl attachment

### Accessory:

Leg Extension (Refer to instructions for hooking up the cables for leg exercises.)

### Adjustable Arm Position:

9



### START

- Make sure you straighten your legs under control; do not allow your knees to hyper-extend.
- Keep the chest lifted, abs tight and maintain a very slight arch in the lower back.
- Try to relax the calf and foot muscles focusing on the hamstrings.
- Set up the leg curl attachment with the bar up as shown, and the bench flat.
- Lie face down on the bench with your lower thighs on the pad, the knees near the pivot point and the ankles under the foam roller pads.
- Point your knees straight down and tighten your inner thigh muscles (as if you are squeezing them together) to stabilize.
- Place your hands on the bench for stability and your forehead on the bench or turned to the side. Do not look up hyper-extending your neck.
- Tighten your abs to prevent spinal motion and very slightly lift your thighs off the pad.

### FINISH

- Slowly bend your knees, upward and then toward your hips without moving your spine and without lifting your hips from the bench.
- Keep the hamstring tight. Slowly straighten the legs, returning to the Start position without losing muscle tension.
- Do not allow them to fully straighten or lock out.

## Leg Exercises

### Lying Leg Extension

**Muscles worked:**

Quadriceps

**Bench Position:**

Flat

**Accessory:**

Foot harness

**Adjustable Arm Position:**

9

**Success Tips**

- Keep your hip and upper thigh motionless throughout the exercise.
- Lift your chest, keep your abs tight and maintain a very slight arch in your low back.

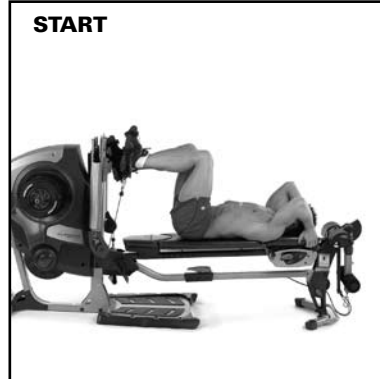

**START**



**FINISH**

**START**

- While sitting on the bench facing the engine, attach one cable to the D-ring on the heel of the foot harness.
- Lie on the bench with your hip flexed and knee bent to approximately 90°.
- Tall users may have to modify this position.
- Feet, ankles and knees should be in line with the cables.

**FINISH**

- Without moving your hips, slowly extend your leg, moving only your knee and lower leg.
- Slowly reverse the motion, returning to the Start position without losing muscle tension.

### Standing Hip Flexion w/ Knee Flexion

**Muscles worked:**

Iliacus, Psoas, Rectus Femoris

**Bench Position:**

Removed

**Accessory:**

Foot harness

**Adjustable Arm Position:**

9

**Success Tips**

- Make sure all the motion is occurring at your hip and the knee.
- Keep the torso tight throughout the motion.

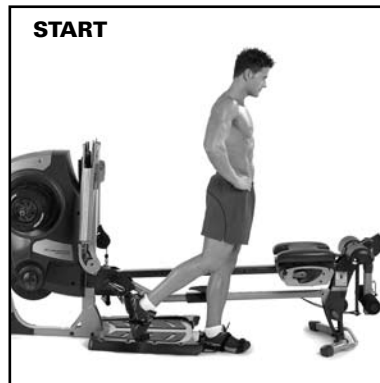

**START**



**FINISH**

**START**

- Stand on the platform on one side of the seat rail facing away from the engine.
- Attach one cable to the D-ring on the heel of the foot harness.
- Straighten but do not lock out the support leg.
- Stand far enough away from the pulley so that there is tension at the start of the motion.

**FINISH**

- Initiate the movement by lifting your knee up toward your torso, allowing your knee to bend without allowing any movement in your waist or lower back.
- After lifting your knee as high as possible, return to the Start position. Repeat with the other leg.

## Leg Exercises

### Standing Leg Kickback – Hip and Knee Extension

#### Muscles worked:

Gluteus Maximus; Hamstring muscles

#### Bench Position:

Removed

#### Accessory:

Foot Harness

#### Adjustable Arm Position:

9

#### Success Tips

- Keep your chest lifted, spine aligned, abs tight and a very slight arch in your lower back.
- Do not bend from waist or lower back.



START

#### START

- Stand to one side of the Seat Rail, facing the engine.
- Secure the Foot Harness around the ankle furthest from the rail. Bend this leg approximately 90°.
- Bend forward 30-40° from your hips (not your waist) and very slightly bend the knee of your supporting leg.



FINISH

#### FINISH

- Extend the active leg backwards, straightening the knee.
- Slowly move your leg as far as you can, without allowing any movement at the waist, knee or lower back.
- Slowly return to the Start position.

### Standing Hip Extension – (knee flexed)

#### Muscles worked:

Gluteus Maximus; Hamstring muscles

#### Bench Position:

Removed

#### Accessory:

Foot Harness

#### Adjustable Arm Position:

9

#### Success Tips

- Keep your chest lifted, spine aligned, abs tight and a very slight arch in your lower back.
- Do not bend from waist or lower back.
- Keep tension on the cable. Do not let the ball on the cable rest against the pulley.



START

#### START

- Stand to one side of the Seat Rail, facing the engine.
- Secure the Foot Harness around the foot furthest from the rail. Bend this leg approximately 90°.
- Bend forward 30-40° from your hips (not your waist) and very slightly bend the knee of your supporting leg.



FINISH

#### FINISH

- Initiate the movement by tightening your glutes and hamstrings. Slowly pivot your leg from your hip. Move your entire leg backward, to a straight position.
- Slowly move your leg as far as you can, without allowing any movement at the waist or lower back.
- Slowly return to Start position.

## Leg Exercises

### Ankle Eversion

#### Muscles worked:

Peroneals

#### Bench Position:

Flat Bench Forward

#### Accessory:

Foot Harness

#### Adjustable Arm Position:

8

#### Success Tips

- Movement should occur only at the ankle—keep the rest of your body motionless.
- Keep abs tight and do not lift your hips or excessively arch your back.
- You should feel tension in the outside of your calf throughout the entire motion



START



FINISH

#### START

- Sit on the Bench, with one side to the engine.
- Attach a Foot Harness on the foot farthest from the pulley. Snap on the top ring to the cable.
- Straighten the attached leg and sit up straight.
- Allow the foot to rotate toward the engine, keeping tension in the cables.

#### FINISH

- Slowly rotate your foot outward, away from engine.
- Then, maintaining tension, slowly return to the Start position.

### Ankle Inversion

#### Muscles worked:

Tibialis Anterior and Posterior

#### Bench Position:

Flat Bench Forward

#### Accessory:

Foot Harness

#### Adjustable Arm Position:

8

#### Success Tips

- Movement should occur only at the ankle—keep the rest of your body motionless.
- Keep abs tight and do not lift your hips or excessively arch your back.
- You should feel tension in the inside of your calf throughout the entire motion



START



FINISH

#### START

- Sit on the Bench, with one side to the engine.
- Attach a Foot Harness on the foot closest to pulley.
- Straighten the attached leg and sit up straight.
- Allow the foot to rotate toward the engine, keeping tension in the cables.

#### FINISH

- Slowly rotate your foot inward, away from engine.
- Then, maintaining tension, slowly return to the Start position.

# Leg Exercises

## Hip Abduction

### Muscles worked:

Gluteus Minimus; Gluteus Medius; Tensor Fasciae Latae



### Bench Position:

Not used

### Accessory:

Foot Harness

### Adjustable Arm Position:

8

### Success Tips

- Keep your chest lifted, spine aligned, abs tight and a slight arch in your lower back.
- Do not bend from waist or lower back.
- Keep your abs tight throughout movement.
- Keep working leg straight or only very slightly bent.
- Use only a small range of motion.

### VARIATIONS

You can perform hip abduction exercises from a seated position, as well.



START



FINISH

### START

- Stand to one side of the Seat Rail, one side next to engine.
- Secure Foot Harness on the foot furthest from the engine. Keep leg slightly bent.
- Adjust your position so that there is some tension in the cables at the start of this exercise.
- You may use your hand on the swing arm to stabilize movement.

### FINISH

- Slowly move the attached leg outward, away from the engine, at a 30-45° angle, keeping your hips and spine motionless.
- Slowly return to the Start position without relaxing tension in your leg.
- Keep your hips level during movement.

## Hip Adduction

### Muscles worked:

Adductors; Gluteus Medius



### Bench Position:

Not used

### Accessory:

Foot Harness

### Adjustable Arm Position:

8

### Success Tips

- Keep your chest lifted, spine aligned, abs tight and a slight arch in your lower back.
- Do not bend from waist or lower back.
- Keep your abs tight throughout movement.
- Keep working leg straight or only very slightly bent.
- Use only a small range of motion.

### VARIATIONS

You can perform hip adduction exercises from a seated position, as well.



START



FINISH

### START

- Stand to one side of the Seat Rail, one side next to engine.
- Secure Foot Harness on the foot closest to the engine. Keep leg slightly bent.
- Adjust your position so that there is some tension in the cables at the start of this exercise.
- You may use your hand on the swing arm to stabilize movement.

### FINISH

- Slowly move the attached leg inward, toward the engine, at a 30-45° angle, keeping your hips and spine motionless.
- Slowly return to the Start position without relaxing tension in your leg.
- Keep your hips level during movement.

## Leg Exercises

### Standing Hip Flexion

#### Muscles worked:

Iliacus, Psoas, Rectus Femoris

#### Bench Position:

Removed

#### Accessory:

Foot harness

#### Adjustable Arm Position:

9

#### Success Tips

- Make sure all the motion is occurring at your hip.
- Keep the torso tight throughout the motion.



START



FINISH

#### START

- Stand on the platform on one side of the seat rail facing away from the engine.
- Attach one cable to the D-ring on the heel of the foot harness.
- Straighten but do not lock out the support leg.
- Stand far enough away from the pulley so that there is tension at the start of the motion.

#### FINISH

- Initiate the movement by moving your whole leg forward, without allowing any movement in your waist or lower back.
- After moving your leg as far as possible, return to the Start position. Repeat with the other leg.

### Standing Hip External Rotation

#### Muscles worked:

Gracilis, Adductor Magnus

#### Bench Position:

Removed

#### Accessory:

Foot harness

#### Adjustable Arm Position:

9

#### Success Tips

- Make sure all the motion is occurring at your hip.
- Keep the torso tight throughout the motion.

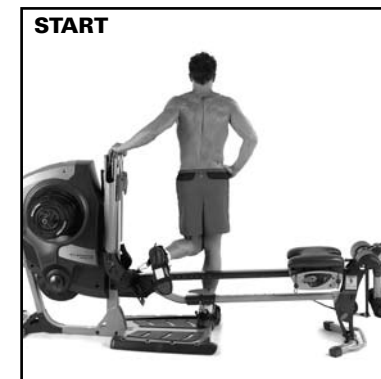

START

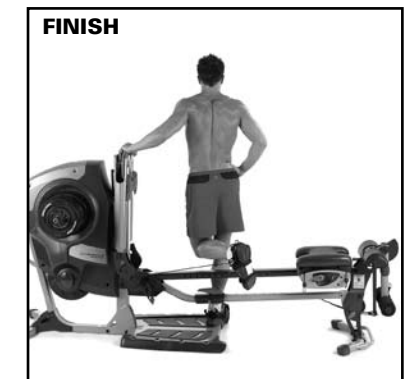

FINISH

#### START

- Stand on the platform on one side of the seat rail facing sideways from the engine.
- Attach one cable to the D-ring on the foot closest to the pulley on the outside edge near the front of your foot.
- Straighten but do not lock out the support leg.
- Stand far enough away from the pulley so that there is tension at the start of the motion.

#### FINISH

- Initiate the movement by moving your whole leg by rotating at the hip, without allowing any movement in your waist or lower back.
- After rotating your leg as far as possible, return to the Start position.
- Repeat with the other leg.

# Leg Exercises

## Standing Hip Internal Rotation

### Muscles worked:

Glute medius posterior fibers, Piriformis and other deep rotators

### Bench Position:

Removed

### Accessory:

Foot harness

### Adjustable Arm Position:

9

### Success Tips

- Make sure all the motion is occurring at your hip.
- Keep the torso tight throughout the motion.

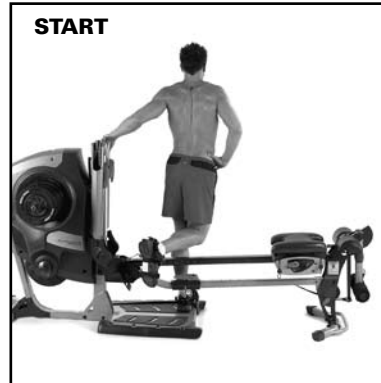

START



FINISH

### START

- Stand on the platform on one side of the seat rail facing sideways from the engine.
- Attach one cable to the D-ring on the outside foot near the front inside edge.
- Straighten but do not lock out the support leg.
- Stand far enough away from the pulley so that there is tension at the start of the motion.

### FINISH

- Initiate the movement by moving your whole leg by rotating at the hip, without allowing any movement in your waist or lower back.
- After rotating your leg as far as possible, return to the Start position.
- Repeat with the other leg.

## Lying Hip External Rotation

### Muscles worked:

Tensor Facia late, Piriformis, Glute medius anterior fibers

### Bench Position:

Removed

### Accessory:

Foot harness

### Adjustable Arm Position:

9

### Success Tips

- Make sure all the motion is occurring at your hip.
- Keep the torso tight throughout the motion.

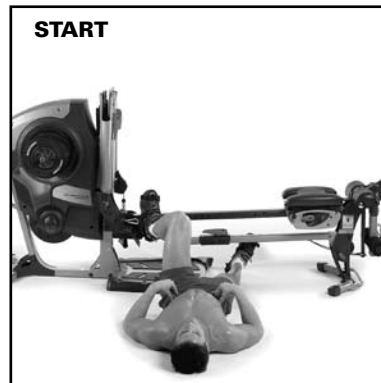

START



FINISH

### START

- Attach one cable to the D-ring on the foot closest to the pulley on the outside edge near the front of your foot.
- Lie on your back with your hip and knee flexed to 90°.
- Position yourself so the cable is pulling at a 90 degree angle off the foot harness.
- Lie far enough away from the pulley so that there is tension at the start of the motion.

### FINISH

- Initiate the movement by moving your whole leg by rotating at the hip, without allowing any movement in your waist or lower back.
- After rotating your leg as far as possible, return to the Start position.
- Repeat with the other leg.

# Leg Exercises

## Leg Press

### Muscles worked:

Quadriceps

### Bench Position:

Removed

### Accessory:

Sliding seat; Leg Press Plate

### Adjustable Arm Position:

9

### Success Tips

- Keep your spine in good posture.
- Straighten but do not lock your knees.
- Keep your quads tightened throughout the entire motion.
- Do not use momentum, **MOVE SLOWLY.**
- Lift your chest, tighten your abs and maintain a very slight arch in your lower back.



### START



### START

- Remove the bench and unlock the rowing seat. (Refer to instructions for hooking up the cables for Leg Press exercises.)
- Sit facing the engine, your feet on the leg press plate.
- Bend your knees and hips slowly allowing yourself to slide toward the engine.
- Rest your hands in a comfortable position.

### FINISH



### FINISH

- Straighten your legs, but do not lock your knees.
- Limit your slide to a position that allows you to still maintain good spinal posture, with your chest lifted, abs tight and a slight arch in your lower back.
- Slowly return to the Start position.

## VARIATION

### Single Leg - Leg Press – Knee Extension w/ hip extension

### Muscles worked:

Quadriceps

### Bench Position:

Sliding seat; Leg Press Plate

### Accessory:

Foot Plate; Leg Press Seat Back

### Adjustable Arm Position:

9

### Success Tips

- Keep your spine in good posture.
- Tighten, but do not lock your knees.
- Keep your quads tight through the entire motion.
- Move slowly and under control.
- Lift your chest, keep your abs tight and maintain a very slight arch in your low back.

### START

- Remove the bench and set up the machine with the sliding seat, back support pad and leg press plate. (Refer to instructions for hooking up the cables for Leg Press exercises.)
- Sit facing the engine with your foot on the foot plate positioned comfortably for you to press with one leg at a time.
- Bend your knees and hips allowing yourself to slide toward the engine.
- Limit this Start position that still allows you to maintain good posture and from flexing your knee past 90°.

### FINISH

- Straighten your leg by pressing through your heel without taking your front foot off the plate. Move to a straightened position without locking out your knees.
- Slowly reverse the motion, returning to the Start position without losing muscle tension.



## Leg Exercises

### Calf Raise

#### Muscles worked:

Gastrocnemius; Soleus

#### Bench Position:

Removed

#### Accessory:

Sliding seat; Foot Harness; Leg Press Plate

#### Adjustable Arm Position:

8

#### Success Tips

- Keep your chest lifted, spine aligned, abs tight and a slight arch in your lower back.
- Do not bend from waist or lower back.
- Keep your abs tight throughout movement.
- Keep legs straight or only very slightly bent.
- Use only a small range of motion.



START



FINISH

#### START

- Remove the bench and unlock the rowing seat. (Refer to instructions for hooking up the cables for Leg Press exercises.)
- Sit on the seat facing the engine.
- Place the balls of your feet on the Leg Press Plate.
- Push back and straighten your legs, but do not lock your knees.

#### FINISH

- Slowly press the balls of your feet into the frame and pull your heels towards your knees
- Slowly return to the Start position without relaxing.

### Dorsi Flexion

#### Muscles worked:

Tibia Dorsi

#### Bench Position:

Removed

#### Accessory:

Sliding seat; Foot Harness

#### Adjustable Arm Position:

9

#### Success Tips

- Move only at the ankle.
- Move your toe as far forward as possible, but don't let the handle slip off.



START



FINISH

#### START

- Sit on the bench facing toward the engine.
- Attach the Foot Harness on your right foot, bend your knee, place your heel on the bench, and sit upright so that there is tension on the cable.
- Your left foot should be flat on the platform, hands on your waist.

#### FINISH

- Slowly pull the top of your foot toward you.
- Slowly return to the Start position.
- Repeat with the left ankle.



# Muscle Chart

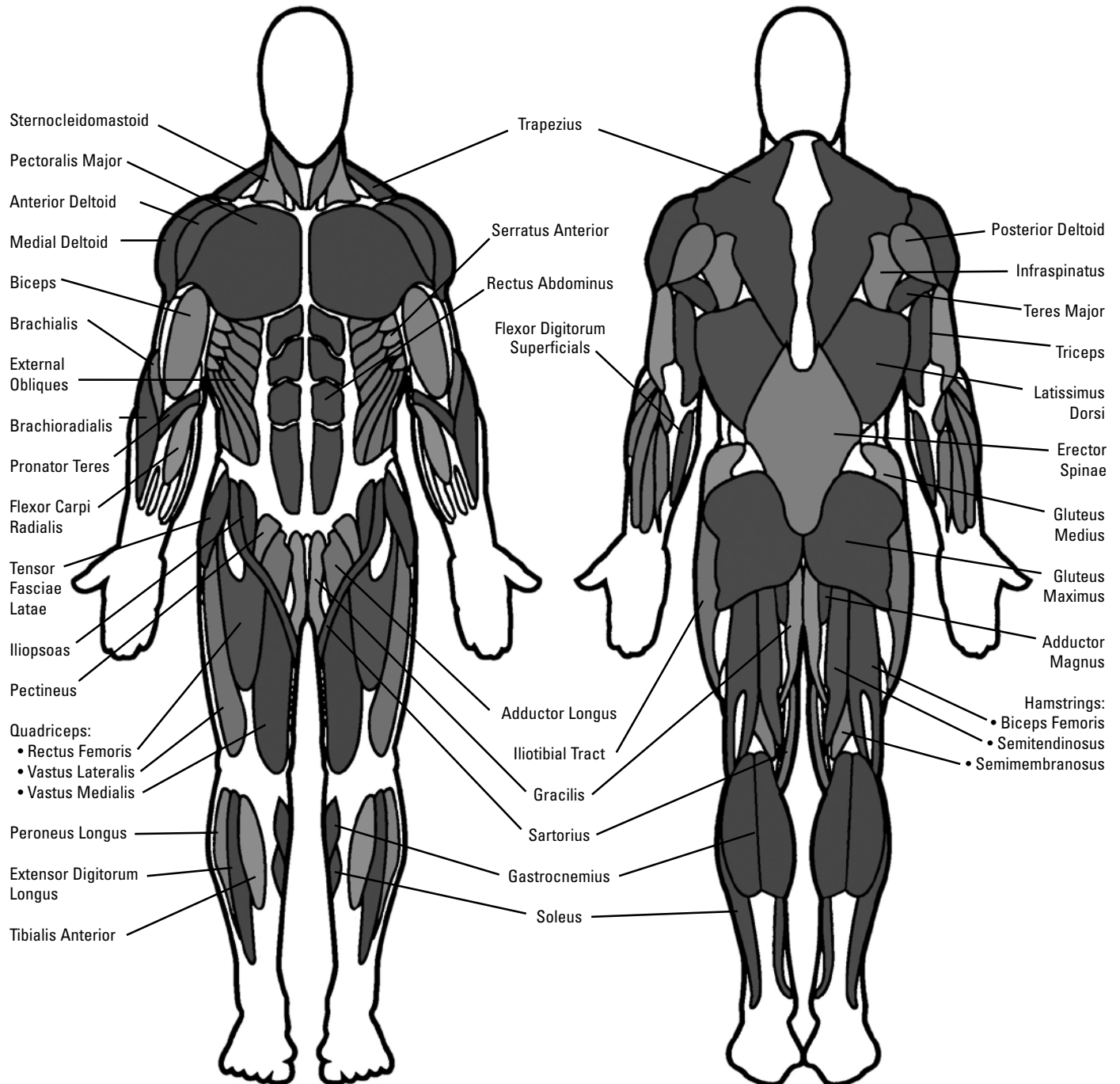

# Exercise Log

Please feel free to make copies of this chart to continue your exercise log.

EXERCISE	DATE	DATE	DATE	DATE	DATE	DATE
<i>Bench Press</i>	Sets	2				
	Reps	10, 9				
	Resistance	120, 130				
	Sets					
	Reps					
	Resistance					
	Sets					
	Reps					
	Resistance					
	Sets					
	Reps					
	Resistance					
	Sets					
	Reps					
	Resistance					
	Sets					
	Reps					
	Resistance					
	Sets					
	Reps					
	Resistance					
	Sets					
	Reps					
	Resistance					
	Sets					
	Reps					
	Resistance					
	Sets					
	Reps					
	Resistance					

**FAST FAT LOSS  
NOW!**

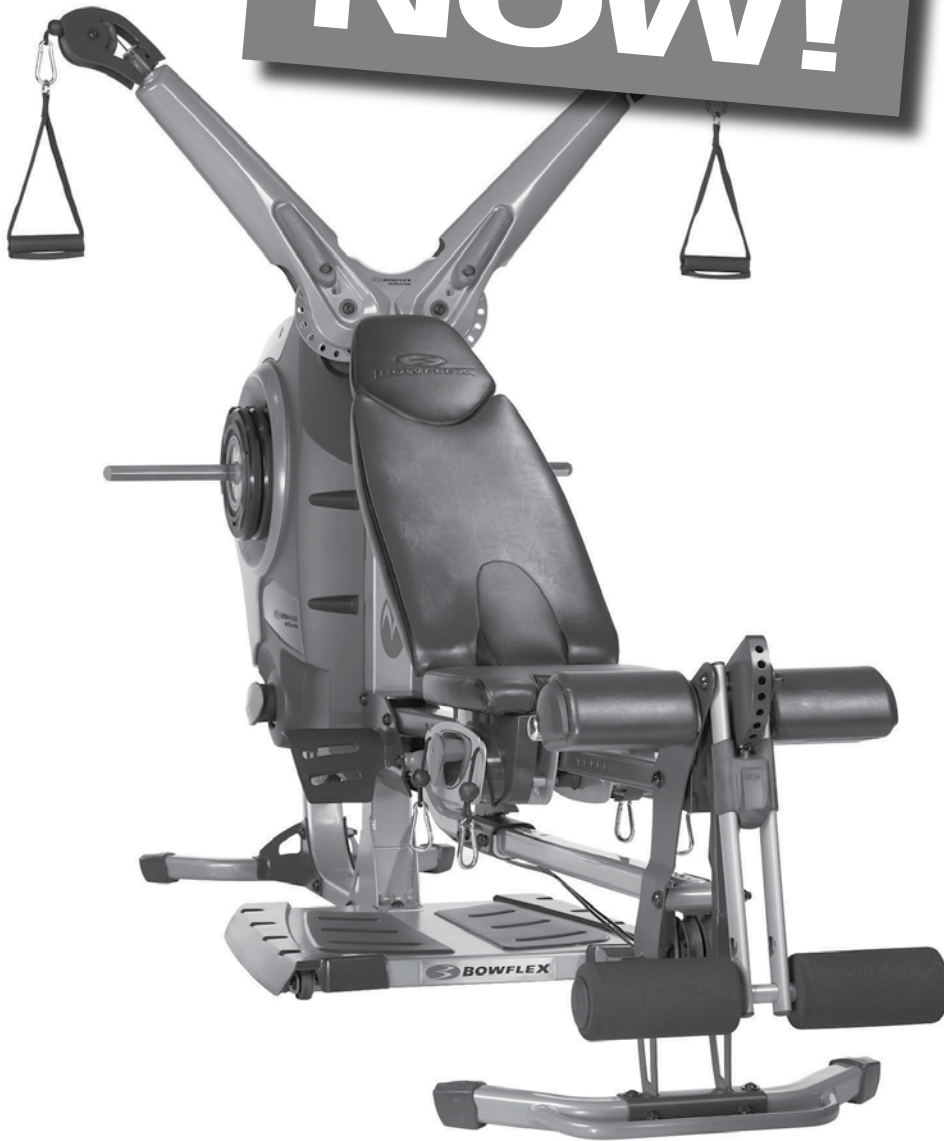

## ***The Bowflex® Body Leanness Program***

*By Ellington Darden, Ph.D.*

The following program was created by Dr. Ellington Darden. It contains a rigorous fitness and dietary program. Please consult your physician before beginning any fitness or dietary program.

Some of the names of the exercises listed in this program have been changed in order to match the names of the exercises in this manual. The exercises themselves have *not* been changed, in order to preserve the integrity of Dr. Darden's Study.

## Introduction

---

### The Bowflex® Body Leanness Program

This program is scientifically designed for maximal fat loss over six weeks. It is important that you practice every aspect of the plan to achieve optimum results.

The program separates into three two-week stages. During each stage you will exercise, control the number and quality of calories you consume, and drink plenty of ice-cold water.

Before starting the exercise routine you must be familiar with your Bowflex Revolution®. You should experiment with finding the proper amount of resistance to use on each exercise. You should be able to perform 8 repetitions, but not more than 12 repetitions, for each exercise. It is essential that you learn how to perform each movement before trying a complete circuit, because part of the effectiveness of the training depends on minimal rest between each exercise.

### **WARNING!**

Before beginning this program consult your physician or health care professional. Show this plan and your Bowflex Revolution™ Owner's Manual to your physician or health care professional. Only he or she can determine if this course is appropriate for your particular age and condition. If you experience any light-headedness, dizziness, or shortness of breath while exercising, stop the movement and consult a physician.

---

**Make sure you read your Bowflex Revolution™ Owner's Manual BEFORE attempting a workout.**

---

There are a few people who should not try this program: Children and teenagers; pregnant women; women who are breast feeding; diabetics; individuals with certain types of heart, liver, or kidney disease; and those suffering from certain types of arthritis. This should not be taken as an all inclusive list. Some people should follow the course only with their physician's specific guidance. Play it safe and consult a health care professional.

## A Personal Guarantee From Dr. Ellington Darden

---

Dear Bowflex® Enthusiast,

I'm excited, really excited! I'm elated because I've developed an exercising and eating program that produces fat loss faster than any plan I've ever tested.

The men involved in my research, for example, had an average fat loss of 27.95 pounds (12.68 kg) per man. Women on the same program averaged a reduction of 16.96 pounds (7.69 kg). Best of all, these dramatic results were achieved—not in six months—but in only six weeks!

That's right. Similar results can be accomplished by you in six short weeks, which include just 18 workouts (3 per week) on the Bowflex® machine.

The Bowflex® home gym was a significant part of the results. The exercises performed on it allowed the participants to build muscle, which accelerated their metabolisms, and produced faster and greater fat losses.

The plan worked so well that it became known as The Bowflex® Body Leanness Program.

Leanness means to strip away the fat from under the skin as well as at deeper levels. Leanness also implies a pleasing shape and tone to the skeletal muscles.

You might say leanness is the opposite of fatness because the people involved in my research certainly got rid of their excessive fatness in record time.

All the guidelines that were applied have been organized in the booklet you are now holding in your hands. It's the next best thing to actually going through one of my research projects. In fact, it's probably better since nothing is experimental. All of the fine points have been tried, tested and proven effective.

If you are overfat, and if you are interested in doing this program, there are several things that you need to understand about my experience. Since 1965, I've trained more than 10,000 overfat individuals. After many years of pushing, coaxing, and listening to these trainees, certain traits became evident to me:

- People are not lazy by choice. They are forced into it by the confusion that surrounds the abundance of fitness information that is available. If these individuals are given simple decisive instructions, they will train very intensely.
- People, if they are provided with specific menus, will drastically alter their eating habits.
- Most of these people, however, will do neither of these challenging things for more than a week—unless they quickly see and feel changes in their body.

The Bowflex® Body Leanness Program emerged from these findings. For you to get the best-possible results, you must be willing to exercise very intensely on the Bowflex® machine and adhere to a strict eating plan.

In return, you'll get simple exercise instructions, specific menus to use, and my guarantee that if you follow the program exactly as directed, you'll observe the pounds and inches disappear on almost a weekly basis.

Now it's your turn to get excited, and get started!

Sincerely,



Dr. Ellington Darden

## Measurements

If you would like to measure your personal before-and-after results, there are several steps you need to take. It is important that you accurately perform each task, then at the end of the six-week program, repeat the process in the same manner.

### Body Weight:

Remove clothing and shoes and record your weight to the nearest quarter pound or hundred grams. Be sure to use the same scale when weighing yourself at the end of the six-week program. For the most accurate recordings, weigh yourself nude in the morning.

Since the program is divided into three two-week segments, you may want to weigh yourself at the end of each two-week period. Understand, however that weight loss is not the best way to determine your success. Fat loss is the key component. To determine the amount of fat you've lost, you'll need to follow the instructions in the next section.

Enter your starting weight on the RESULTS SUMMARY SHEET provided.

### Circumference of Body Parts:

For an even better idea of the changes that will occur to your body in the next six weeks, it is necessary to measure the circumference of certain body parts. This will tell you where the fat is shrinking and what areas are toning up.

#### Use a plastic tape to measure the following:

- 1) Upper arms — hanging and relaxed, midway between the shoulder and elbow.
- 2) 2" (5 cm) above navel — belly relaxed.
- 3) At navel — belly relaxed.
- 4) 2" (5 cm) below navel — belly relaxed.
- 5) Hips — feet together at maximum protrusion of buttocks.
- 6) Thighs — high, just below the buttocks crease with legs apart and weight distributed equally on both feet.

Record each measurement on your Results Summary Sheet.

### Women Measure:

Suprailium, triceps, and thigh.

### Men Measure:

Chest, abdomen, and thigh.

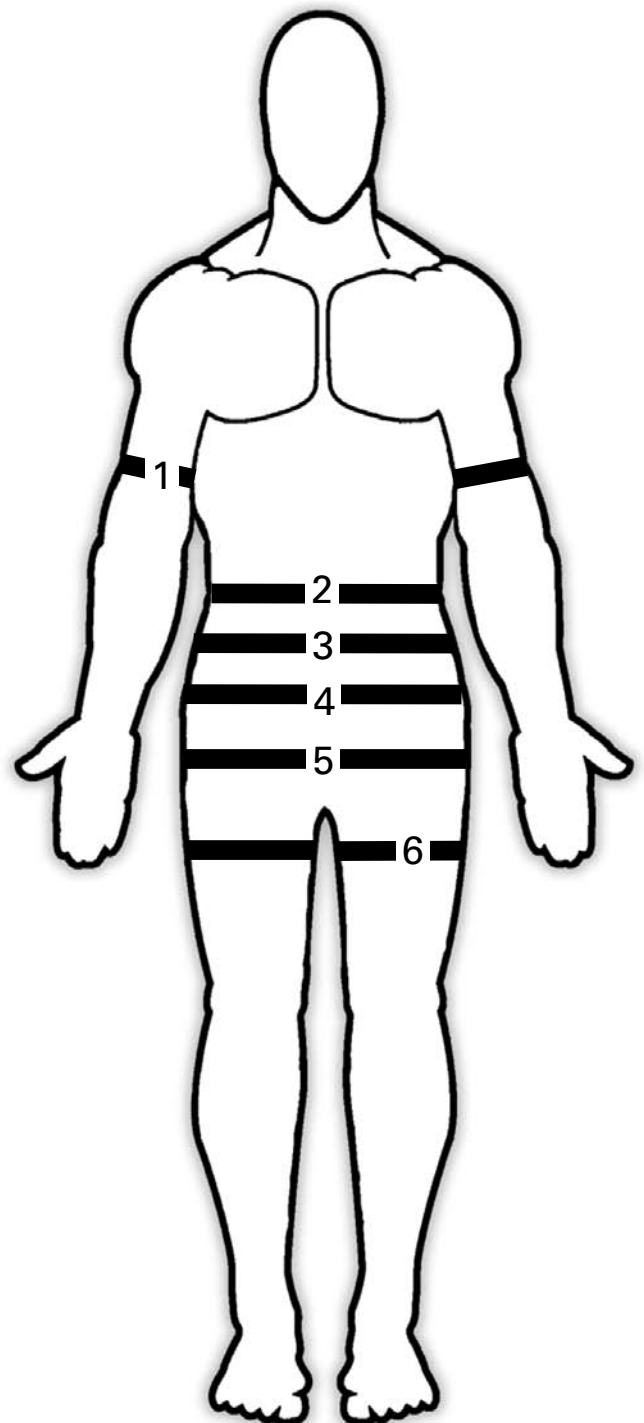



# Measurements

## Skinfold Measurements

To accurately track your progress through this six-week program, it is necessary to take skinfold measurements. By measuring yourself in this way, you will be able to determine your lean-body mass and your body-fat percentage. The goal of this program is to increase your lean-body mass and decrease your body-fat percentage.

Please read this section carefully. Proper measuring techniques are essential to track your success. It is best to have someone measure you. Measuring yourself can lead to inaccurate results.

### Women Measure: Suprailium, Triceps, and Thigh



#### Suprailium

Stand relaxed. Pick up a diagonal skinfold just above the crest of the hip bone on the right side of the waist.



#### Triceps

Stand with right elbow flexed 90 degrees and locate the center of the back of the upper arm midway between the shoulder and the elbow. Relax arm at your side. Pick up skinfold as pictured.



#### Thigh

Stand relaxed with most of the weight on your left leg. Pick up a skinfold in the vertical plane on the front side of the right thigh, midway between the hip and knee joints.

### Men Measure: Chest, Abdomen and Thigh

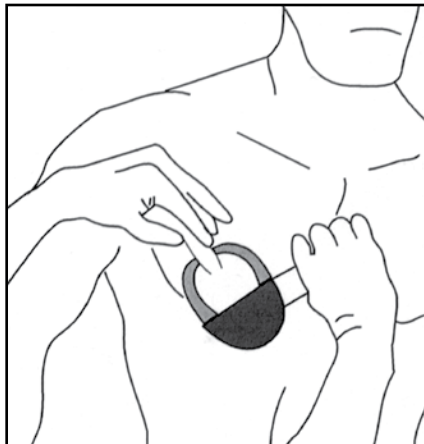

#### Chest

Stand relaxed. Pick up a diagonal skinfold over the right pectorals muscle, midway between the armpit and the nipple.



#### Abdomen

Stand relaxed. Pick up a vertical skinfold on the right side of the navel.

## Measurements

---

### Using Calipers When Measuring Skinfolts

The procedure for measuring skinfold thickness is to grasp firmly with the thumb and forefinger a fold of skin and surface fat and pull it away from the underlying muscle. Take the caliper in your other hand and open the jaws. Clamp the jaws over the pinched skin and fat. The jaws exert constant tension at the point of contact with the skin. The thickness of the double layer of skin and fat can then be read directly from the caliper, which is marked in millimeters.

#### Women

Suprailium \_\_\_\_\_

Triceps \_\_\_\_\_

Thigh \_\_\_\_\_

**Total** \_\_\_\_\_

#### Men

Chest \_\_\_\_\_

Abdomen \_\_\_\_\_

Thigh \_\_\_\_\_

**Total** \_\_\_\_\_

Use these figures on the following chart to determine your body-fat percentage and enter the number on the line below.

**Starting body-fat percentage** \_\_\_\_\_

### Optional Picture Taking

---

Pictures can be the most exciting evaluation you can do. The numbers and the tape measurements are great, but actually seeing differences from comparison photographs of yourself is quite satisfying.

Taking full-length photographs is not difficult, but to see the maximum difference between before and after, you should follow these guidelines.

- 1) Keep everything the same. Wear the same outfit, a snug solid color is best, and have the person taking the picture stand in the same place, with the same setting behind you.
- 2) Make sure you stand against an uncluttered, light background.

- 3) Have the person taking the photograph move away from you until he can see your entire body in the viewfinder.
- 4) Stand relaxed for three pictures, front, right side, and back. Do not try to suck in your stomach.
- 5) Interlace your fingers and place them on top of your head, so the contours of your torso will be plainly visible. Keep your feet 8" (20 cm) apart in all three pictures.
- 6) When you get the film developed tell the processors to make your after photos the same size as your previous ones. This way, your height in both sets of photos is equal and more valid comparisons can be made.

# Determining Your Body Fat

## To Use The Nomogram:

- 1) Locate the sum of your three skinfolds in the right column and mark it.
- 2) Locate your age in years on the far left column and mark it.
- 3) Connect the two marks with a straightedge. Where the straightedge intersects the line in the middle column appropriate to you, you will find your body-fat percentage.

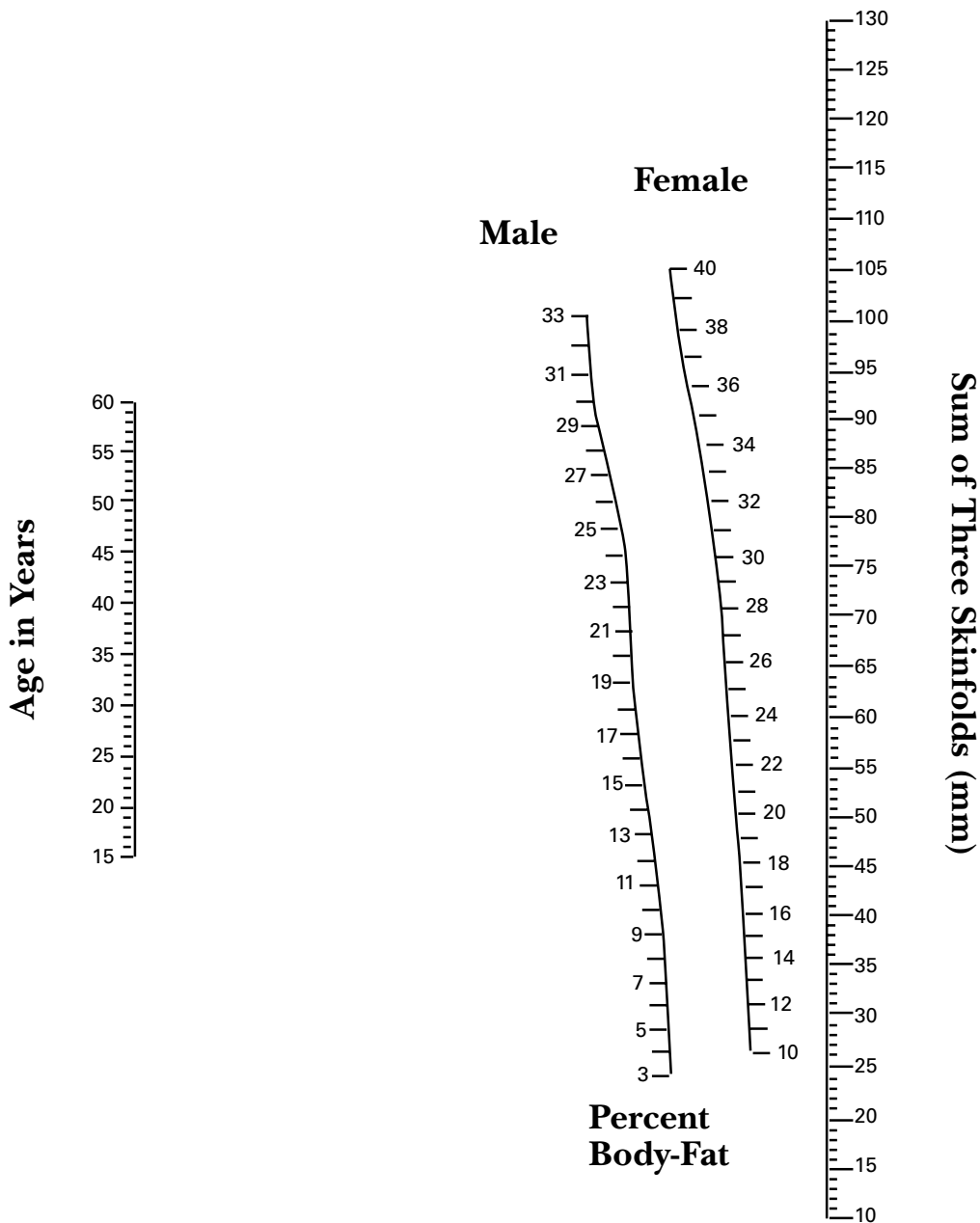

Baun, W.D, Baun, M.R., and Raven, P.B. A nomogram for the estimate of percent body fat from generalized equations. *Research Quarterly for Exercise and Sport*, 52:380-384, 1981.

## Calculating Lean Body Mass

Now that you know your body-fat percentage, you can calculate your lean-body percentage. This will eventually show you how many pounds of muscle were added to your body, after completing the program.

### For Example:

Before the program, Joe weighs 200 pounds (90.7 kg) and measures 30% fat, which amounts to 60 pounds (27.2 kg). Thus, his lean-body mass is 70%, or 140 pounds (63.5 kg).

After the program, Joe weighs 180 pounds (81.6 kg) and is 20% fat, which equals 36 pounds (16.3 kg). His lean-body mass is 80%, or 144 pounds (65.3 kg).

Simple calculations allow us to find the amount of fat Joe lost, and the amount of muscle Joe gained. Before fat weight (60 pounds), minus after fat weight (36 pounds) equals 24 pounds (10.8 kg) of fat lost. After lean-mass weight (144 pounds) minus before lean-mass weight (140 pounds) equals 4 pounds (1.8 kg) of muscle gained.

### Enter Your Information Here: (*Pounds or Kilograms*)

#### *Before*

Body Weight		Fat Percentage		Body Fat Weight
<input style="width: 100%;" type="text"/>	X	<input style="width: 100%;" type="text"/>	=	<input style="width: 100%;" type="text"/>
Body Weight		Weight of Body Fat		Lean-Body Weight
<input style="width: 100%;" type="text"/>	-	<input style="width: 100%;" type="text"/>	=	<input style="width: 100%;" type="text"/>

*Use the Same Factors to Calculate After Six Weeks.*

#### *After*

Body Weight		Fat Percentage		Body Fat Weight
<input style="width: 100%;" type="text"/>	X	<input style="width: 100%;" type="text"/>	=	<input style="width: 100%;" type="text"/>
Body Weight		Weight of Body Fat		Lean-Body Weight
<input style="width: 100%;" type="text"/>	-	<input style="width: 100%;" type="text"/>	=	<input style="width: 100%;" type="text"/>

#### *Final Results*

<i>Before</i> Body Fat Weight		<i>After</i> Body Fat Weight		Total Fat Lost
<input style="width: 100%;" type="text"/>	-	<input style="width: 100%;" type="text"/>	=	<input style="width: 100%;" type="text"/>
<i>After</i> Lean-Mass Weight		<i>Before</i> Lean-Mass Weight		Total Lean-Mass Gained
<input style="width: 100%;" type="text"/>	-	<input style="width: 100%;" type="text"/>	=	<input style="width: 100%;" type="text"/>

## Your Results Summary Sheet

Name \_\_\_\_\_ Age \_\_\_\_\_

Height \_\_\_\_\_ Weight Loss \_\_\_\_\_

Weight Before \_\_\_\_\_ Muscle Gain \_\_\_\_\_

Weight After \_\_\_\_\_ Fat Loss \_\_\_\_\_

Please follow the instructions in the "Measurements" section for measuring circumferences.

Measurements	Before	After	Difference
Right Arm	_____	_____	_____
Left Arm	_____	_____	_____
2" (5 cm) Above Navel	_____	_____	_____
Navel	_____	_____	_____
2" (5 cm) Below Navel	_____	_____	_____
Hips	_____	_____	_____
Right Thigh	_____	_____	_____
Left Thigh	_____	_____	_____
		Total	_____
Percent Body Fat	_____	_____	_____

If you wish to submit your results, please send to: Bowflex Results, 16400 SE Nautilus Drive, Vancouver, WA 98683. Or you may fax this sheet to Bowflex Results at 1-360-694-7755. Please include your name, address, and phone number. Submissions may be selected for use in promotional marketing materials.

## The Workouts

### GUIDELINES Week 1&2

All exercises should be practiced with one set of 8 to 12 repetitions. The style of performance is very important. The movement for each repetition should be 4 seconds in the positive phase and 4 seconds in the negative. Keep the motion slow and smooth. When 12 repetitions are accomplished, increase the resistance by approximately 5 percent. Keep the time between exercises to a minimum, no longer than **60** seconds. No workout should take more than 30 minutes to complete. Perform each workout three days a week.

Exercise	Sets	Reps
Leg Extension	1	8-12
Bench Press	1	8-12
Lying Biceps Curl	1	8-12
Seated Shoulder Press	1	8-12
Seated Abdominal Crunch	1	8-12

### GUIDELINES Week 3&4

All exercises should be practiced with one set of 8 to 12 repetitions. The style of performance is very important. The movement for each repetition should be 4 seconds in the positive phase and 4 seconds in the negative. Keep the motion slow and smooth. When 12 repetitions are accomplished, increase the resistance by approximately 5 percent. Keep the time between exercises to a minimum, no longer than **45** seconds. No workout should take more than 30 minutes to complete. Perform each workout three days a week.

Exercise	Sets	Reps
Leg Extension	1	8-12
Bench Press	1	8-12
Lying Biceps Curl	1	8-12
Seated Shoulder Press	1	8-12
Rear Deltoid Rows*	1	8-12
Seated Triceps Extension	1	8-12
Seated Abdominal Crunch	1	8-12

### GUIDELINES Week 5&6

All exercises should be practiced with one set of 8 to 12 repetitions. The style of performance is very important. The movement for each repetition should be 4 seconds in the positive phase and 4 seconds in the negative. Keep the motion slow and smooth. When 12 repetitions are accomplished, increase the resistance by approximately 5 percent. Keep the time between exercises to a minimum, no longer than **30** seconds. No workout should take more than 30 minutes to complete. Perform each workout three days a week.

Exercise	Sets	Reps
Leg Extension	1	8-12
Leg Press	1	8-12
Bench Press	1	8-12
Lying Biceps Curl	1	8-12
Lying Shoulder Pullover	1	8-12
Reverse Fly	1	8-12
Rear Deltoid Rows*	1	8-12
Seated Triceps Extension	1	8-12
Seated Abdominal Crunch	1	8-12

\* The Upright Row exercise was used in Dr. Darden's original study. Although many people have used this exercise for years, recent information in the Physical Therapy field has caused the authors of this manual to caution against performing this exercise because of the unnatural twisting movement created in the shoulder joint. We suggest you substitute Rear Deltoid Rows for the Upright Row exercise.

## Eating Guidelines

You will be following a reduced-calorie nutrition program, which is divided into three two-week segments. The program is a proven method for achieving maximal fat loss over a six-week period. It consists of a carbohydrate-rich, descending-calorie eating plan, and a superhydration routine.

### Follow a Carbohydrate-Rich, Descending-Calorie Eating Plan:

Approximately 60 percent of the daily calories should be from carbohydrates. The other 40 percent will be equally divided between proteins and fats. The 60:20:20 ratio of carbohydrates, proteins, and fats is ideal for maximum fat loss.

### Keep Menus Simple and Food Substitutions to a Minimum:

Research has established that successful dieters prefer the same foods each day for breakfast and lunch. They like variety, however, for dinner. Detailed menus and food choices are included later in this manual.

If you must vary from the menu items, try to stay within the 60:20:20 ratio of carbohydrates, proteins and fats.

For Example			
Daily Amount	Carbohydrate	Protein	Fat
Calories	60%	20%	20%
2000	1200	400	400
1900	1140	380	380
1800	1080	360	360
1700	1020	340	340
1600	960	320	320
1500	900	300	300
1400	840	280	280
1300	780	260	260
1200	720	240	240
1100	660	220	220
1000	600	200	200

### Avoid Too Much Stress:

Too much stress of any kind can cause the body to actually preserve fat stores. You should relax more. An after-dinner walk at a leisurely pace is helpful. Extra sleep is suggested, since sleep facilitates fat loss and muscle recovery. Furthermore, to keep the body well rested, ***no other exercises or activities are allowed during the six-week program.*** This is a scientifically proven program that works. More is not better. Any additional exercise other than the amount recommended can and will harm your fat loss.

## Superhydrate Your System

---

Drinking plenty of water is essential to the success of this program. Drinking the recommended amount of water can seem like a challenge at first. Stick with it. Carry a large sport bottle or similar item with you throughout the day. After several weeks, you will find that you actually thirst for more and more water, and the amounts recommended are easily reached.

Superhydration aids fat loss in a number of ways. First, the kidneys are unable to function without adequate water. When they do not work to capacity some of their load is dumped onto the liver.

This diverts the liver from its primary function, which is to metabolize stored fat into usable energy. Because it's performing the chores of the water-depleted kidneys, the liver metabolizes less fat.

Second, overeating can be averted through water intake, as water can keep the stomach feeling full and satisfied between meals.

Third, ice-cold water requires calories to warm it to core body temperature. In fact, *1 US gallon of ice cold water (3.8 l) generates 123 calories of heat energy.*

You'll be drinking from 1 to 1 5/8 US gallons (3.8 - 6.2 l) of water each day on the following superhydration schedule:

**Week 1** = drink four 32-oz. bottles (3.8 l) of ice-cold water per day.

**Week 2** = drink four and a half 32-oz. bottles (4.3 l) of ice-cold water per day.

**Week 3** = drink five 32-oz. bottles (4.6 l) of ice-cold water per day.

**Week 4** = drink five and a half 32-oz. bottles (5.2 l) of ice-cold water per day.

**Week 5** = drink six 32-oz. bottles (5.7 l) of ice-cold water per day.

**Week 6** = drink six and a half 32-oz. bottles (6.2 l) of ice-cold water per day.

Don't be surprised if you have to make more than a dozen trips to the rest room, especially during the first week of the program. Remember, your body is an adaptive system, and it will soon accommodate the increased water consumption.

**Note:** *Although it is doubtful that you could ever drink too much water, a few ailments can be negatively affected by large amounts of fluid. For example, anyone with a kidney disorder, or anyone who takes diuretics, should consult a physician before going on the recommended water-drinking schedule. If you have any doubts about the recommendations, play it safe and check with your doctor.*



# The Eating Plan

---

The menus in the Bowflex® eating plan are designed for maximum fat-loss effectiveness and nutritional value. For best results, follow them exactly.

Every attempt has been made to utilize current popular brand names and accurate calorie counts, which are listed in the menus. But as you probably realize the products are sometimes changed or discontinued. If a listed item is not available in your area, you'll need to substitute a similar product. Become an informed label reader at your supermarket. Ask questions about any products you don't understand. Supermarket managers are usually helpful. If they don't have an answer to your question, they will get it for you.

Each day you will choose a limited selection of foods for breakfast and lunch. Most people can consume the same basic breakfast and the same basic lunch for months with little modification. Ample variety during your evening meal, however, will make daily eating interesting and enjoyable. Additionally, the eating plan includes a mid-afternoon and late-night snack to keep your energy high and your hunger low.

Begin Week 1 on Monday and continue through Sunday. Week 2 is a repeat of Week 1. Calories for each food are noted in parentheses. A shopping list follows.

The eating plan for the next six weeks descends:

**Week 1 & 2:**

Men 1500 calories per day.

Women 1200 calories per day.

**Week 3 & 4:**

Men 1400 calories per day.

Women 1100 calories per day.

**Week 5 & 6:**

Men 1300 calories per day.

Women 1000 calories per day.

You'll always have a 300 calorie breakfast, a 300 calorie lunch, and a 300 calorie dinner (women), or 500 calorie dinner (men). With each two-week descend, only your snack calories will change: from 400 to 300 to 200 calories per day (men), or 300 to 200 to 100 calories per day (women). For each of your five daily meals, you'll have at least three choices.

Everything has been simplified so even the most kitchen-inept man or woman can succeed. Very little cooking is required. All you have to do is read the menus, select your food choices, and follow the directions. It's as simple as that.

If you find that you wish to vary from the outline menu items try to stay with in the 60:20:20 ratio of carbohydrates, proteins, and fats.

# The Eating Plan – US Measurements

**Breakfast = 300 calories**

**Choice of bagel, cereal or shake.**

**Bagel**

1 plain bagel, Sarah Lee® (frozen) (210)  
 3/4 oz. light cream cheese (45)  
 1/2 C. orange juice, fresh or frozen (55)  
 Any beverage without calories, caffeine, or sodium, such as decaffeinated coffee or tea.

**Cereal**

1.5 oz. (42 grams) serving equals approximately 165 calories.  
 Choice of one: Kellogg's® Low Fat Granola (without raisins), General Mills® Honey Nut Clusters, General Mills® Basic 4  
 1/2 C. skim milk (45)  
 3/4 C. orange juice (82)  
 Noncaloric beverage

**Shake (choice of one shake)**

Place ingredients in blender. Blend until smooth.

**Banana-Orange Shake**

1 large banana (8 3/4 inches long) (100)  
 1/2 C. orange juice (55)  
 1/2 C. skim milk (45)  
 2 T. wheat germ (66)  
 1 t. safflower oil (42)  
 2 ice cubes (optional)

**or Chocolate or Vanilla Shake**

1 packet Carnation® Instant Breakfast, Champion UltraMet®, or another diet shake powder that contains the appropriate calories (100)  
 1 C. skim milk (90)  
 1/2 large banana (8 3/4 inches long) (50)  
 1 t. safflower oil (42)  
 1 t. Carnation® Malted Milk powder (20)  
 2 ice cubes (optional)

**Lunch = 300 calories.**

**Choice of sandwich, soup or salad.**

**Sandwich**

2 slices whole wheat bread (140)  
 2 t. Promise Ultra® Vegetable Oil Spread (24)  
 2 oz. white meat (about 8 thin slices), chicken or turkey (80)  
 1 oz. fat-free cheese (1 1/2 slices) (50)  
 (Opt.: Add to bread 1 t. Dijon mustard (0)  
 Noncaloric beverage

**Soup (choice of one soup)**

• Healthy Choice® Hearty Chicken, 15-oz. can (260), or

• Campbell's® Healthy Request Hearty Vegetable Beef, 16-oz. can (260)  
 1/2 slice whole-wheat bread (35)  
 Noncaloric beverage

**Chef Salad**

2 C. lettuce, chopped (20)  
 2 oz. white meat, chicken or turkey (80)  
 2 oz. fat-free cheese (100)  
 4 slices tomato, chopped (28)  
 1 T. Italian, fat-free dressing (6)  
 1 slice whole wheat bread (70)  
 Noncaloric beverage

**Mid-Afternoon Snack**

**Men**—200 calories for Weeks 1&2;  
 150 calories for Weeks 3&4;  
 100 calories for Weeks 5&6.

**Women**—150 calories for Weeks 1&2;  
 100 calories for Weeks 3&4;  
 50 calories for Weeks 5&6.

**Choose calories from:**

1 large banana (8 3/4 inches long) (100)  
 1 apple (3-inch diameter) (100)  
 1/2 cantaloupe (5-inch diameter) (94)  
 5 dried prunes (100)  
 1 oz. (2 small 1/2 oz. boxes) raisins (82)  
 1 C. light, nonfat, flavored yogurt (100)

**Dinner**

**Men**—500 calories, **Women**—300 calories

**Choice of tuna salad dinner, steak dinner or frozen microwave dinner.**

**Tuna Salad Dinner**

In a large bowl, mix the following:  
 1 6-oz. can chunk light tuna in water (180)  
 1 T. Hellmann's® Light, Reduced-Calorie Mayonnaise (50)  
 2 T. sweet pickle relish (40)  
 1/4 C. whole kernel corn, canned, no salt added (30)  
 Noncaloric beverage

**Men add:**

1/2 C. sliced white potatoes, canned (45)  
 2 slices whole wheat bread (140)

**Steak Dinner**

3 oz. lean sirloin, broiled (176)  
 1/2 C. sweet peas, canned, no salt added (60)  
 1/2 C. beets, canned (35)  
 1/2 C. skim milk (45)

Noncaloric beverage

**Men add:**

2 slices whole wheat bread (140)  
 1 t. Promise Ultra® Vegetable Oil Spread (12)  
 1/2 C. skim milk (45)

**Frozen Microwave Dinner**

**Choice of one meal:**

• Glazed Chicken Dinner, Lean Cuisine® (230)  
 2/3 C. skim milk (60)  
 Noncaloric beverage  
 • Lasagna with Meat Sauce, Lean Cuisine® (240)  
 1/2 C. skim milk (45)  
 Noncaloric beverage  
 • Macaroni and Cheese, Weight Watchers® (260)

1/2 C. skim milk (45)

Noncaloric beverage

• Broccoli & Cheddar Cheese Sauce over Baked Potato, Lean Cuisine® Lunch Express (250)

1/2 C. skim milk (45)

Noncaloric beverage

• Grilled Turkey Breast, Healthy Choice® (260)

1/2 C. skim milk (45)

Noncaloric beverage

**Men add:**

2 slices whole wheat bread (140)  
 2 t. Promise Ultra® Vegetable Oil Spread (24)  
 1/2 C. skim milk (45)

**Late-Night Snack**

**Men**—200 calories for 1&2; 150 calories for Weeks 3&4; 100 calories for Weeks 5&6.

**Women**—150 calories for Weeks 1&2; 100 calories for Weeks 3&4; 50 calories for Weeks 5&6.

**Choose calories from afternoon snack selections plus the following:**

1/2 C. low-fat frozen yogurt (100)  
 2 C. light, microwave popcorn (100)

# The Eating Plan – Metric Measurements\*

---

## Breakfast = 300 calories

---

### Choice of bagel, cereal or shake.

#### Bagel

1 plain bagel, Sarah Lee® (frozen) (210)  
 21 g light cream cheese (45)  
 120 ml orange juice, fresh or frozen (55)  
 Any beverage without calories, caffeine, or sodium, such as decaffeinated coffee or tea.

#### Cereal

42 gram serving equals approximately 165 calories.  
 Choice of one: Kellogg's® Low Fat Granola (without raisins), General Mills® Honey Nut Clusters, General Mills® Basic 4  
 120 ml skim milk (45)  
 177 ml orange juice (82)  
 Noncaloric beverage

#### Shake (choice of one shake)

Place ingredients in blender. Blend until smooth.

##### Banana-Orange Shake

1 large banana (22 cm long) (100)  
 120 ml orange juice (55)  
 120 ml skim milk (45)  
 15 ml wheat germ (66)  
 5 ml safflower oil (42)  
 2 ice cubes (optional)

##### or Chocolate or Vanilla Shake

1 packet Carnation® Instant Breakfast, Champion UltraMet®, or another diet shake powder that contains the appropriate calories (100)  
 240 ml skim milk (90)  
 1/2 large banana (22 cm long) (50)  
 5 ml safflower oil (42)  
 5 ml Carnation® Malted Milk powder (20)  
 2 ice cubes (optional)

---

## Lunch = 300 calories.

---

### Choice of sandwich, soup or salad.

#### Sandwich

2 slices whole wheat bread (140)  
 10 ml Promise Ultra® Vegetable Oil Spread (24)  
 57 g white meat (about 8 thin slices), chicken or turkey (80)  
 28 g fat-free cheese (1 1/2 slices) (50)  
 (Opt.: Add to bread 5 ml Dijon mustard (0)  
 Noncaloric beverage

#### Soup (choice of one soup)

- Healthy Choice® Hearty Chicken, 420 g can (260), or
- Campbell's® Healthy Request Hearty Vegetable Beef, 450 g can (260)  
 1/2 slice whole-wheat bread (35)  
 Noncaloric beverage

#### Chef Salad

480 ml lettuce, chopped (20)  
 57 g white meat, chicken or turkey (80)  
 57 g fat-free cheese (100)  
 4 slices tomato, chopped (28)  
 15 ml Italian, fat-free dressing (6)  
 1 slice whole wheat bread (70)  
 Noncaloric beverage

---

## Mid-Afternoon Snack

---

**Men**—200 calories for Weeks 1&2;

150 calories for Weeks 3&4;

100 calories for Weeks 5&6.

**Women**—150 calories for Weeks 1&2;

100 calories for Weeks 3&4;

50 calories for Weeks 5&6.

#### Choose calories from:

1 large banana (22 cm long) (100)  
 1 apple (7.6 cm diameter) (100)  
 1/2 cantaloupe (12.7 cm diameter) (94)  
 5 dried prunes (100)  
 28 g (2 small 14 g. boxes) raisins (82)  
 240 ml light, nonfat, flavored yogurt (100)

---

## Dinner

---

**Men**—500 calories, **Women**—300 calories

### Choice of tuna salad dinner, steak dinner or frozen microwave dinner.

#### Tuna Salad Dinner

In a large bowl, mix the following:  
 1 can (170 g) chunk light tuna in water (180)  
 15 ml Hellmann's® Light, Reduced-Calorie Mayonnaise (50)  
 30 ml sweet pickle relish (40)  
 60 ml whole kernel corn, canned, no salt added (30)  
 Noncaloric beverage  
**Men add:**  
 120 ml sliced white potatoes, canned (45)  
 2 slices whole wheat bread (140)

#### Steak Dinner

85 g lean sirloin, broiled (176)  
 120 ml sweet peas, canned, no salt added (60)  
 120 ml beets, canned (35)  
 120 ml skim milk (45)  
 Noncaloric beverage  
**Men add:**  
 2 slices whole wheat bread (140)  
 5 ml Promise Ultra® Vegetable Oil Spread (12)  
 120 ml skim milk (45)

#### Frozen Microwave Dinner

##### Choose one meal:

- Glazed Chicken Dinner, Lean Cuisine® (230)  
 160 ml skim milk (60)  
 Noncaloric beverage
- Lasagna with Meat Sauce, Lean Cuisine® (240)  
 120 ml skim milk (45)  
 Noncaloric beverage
- Macaroni and Cheese, Weight Watchers® (260)  
 120 ml skim milk (45)  
 Noncaloric beverage
- Broccoli & Cheddar Cheese Sauce over Baked Potato, Lean Cuisine® Lunch Express (250)  
 120 ml skim milk (45)  
 Noncaloric beverage
- Grilled Turkey Breast, Healthy Choice® (260)  
 120 ml skim milk (45)  
 Noncaloric beverage

**Men add:**  
 2 slices whole-wheat bread (140)  
 10 ml Promise Ultra® Vegetable Oil Spread (24)  
 120 ml skim milk (45)

---

## Late-Night Snack

---

**Men**—200 calories for 1&2; 150 calories for Weeks 3&4; 100 calories for Weeks 5&6.

**Women**—150 calories for Weeks 1&2; 100 calories for Weeks 3&4; 50 calories for Weeks 5&6.

#### Choose calories from afternoon snack selections plus the following:

120 ml low-fat frozen yogurt (100)  
 240 ml light, microwave popcorn (100)

\* Nutritionally equivalent products with similar calorie counts may be substituted if recommended products cannot be found.

## Shopping List

---

Quantities needed for listed items will depend on your specific selections. Review your choices and adjust the shopping list accordingly. It may be helpful for you to photocopy this list each week before doing your shopping.

### Staples

Orange juice, skim milk, whole-wheat bread, Promise Ultra® Vegetable Oil Spread, Italian fat-free dressing, Dijon mustard, safflower oil, noncaloric beverages (tea, decaffeinated coffee, diet soft drinks, water).

### Grains

Bagels, Sarah Lee® (frozen)

Cereals – 1.5 oz. (42 g) serving equals approximately 165 calories; Kellogg's® Low-Fat Granola (without raisins), General Mills® Honey Nut Clusters, General Mills® Basic 4.

Wheat germ, malted milk powder, popcorn (microwave light).

### Fruits

Bananas, large (8 3/4 inches [22 cm] long), apples (3-inch [7.6 cm] diameter), cantaloupes (5-inch [12.7 cm] diameter), dried prunes, raisins.

### Vegetables

Lettuce, tomatoes, whole kernel corn (canned no salt added), sweet peas, (canned no salt added), sliced white potatoes (canned), cut beets (canned).

### Dairy

Yogurt (light nonfat), cream cheese (light), cheese (fat-free), low-fat frozen yogurt, Carnation® Instant Breakfast packets, Champion UltraMet® Packets.

### Meat, Poultry, Fish and Entrees

Chicken (thin sliced), turkey (thin sliced), tuna (canned in water), sirloin steak (lean).

### Canned soup:

Healthy Choice® Hearty Chicken, Campbell's® Healthy Request Hearty Vegetable Beef.

### Frozen microwave dinners or entrees:

Lean Cuisine® Glazed Chicken Dinner, Lean Cuisine® Lasagna with Meat Sauce, Lean Cuisine® Lunch Express Broccoli & Cheddar Cheese over Potato, Weight Watchers® Macaroni and Cheese, Healthy Choice® Grilled Turkey Breast.

## Q & A

**Q. I often get headaches when I eat only 1000 calories a day. What should I do?**

A. Your headaches may be caused by going longer than three hours between meals or snacks. Try spacing your meals and snacks where there are fewer hours between them.

Some people who are used to drinking regular coffee with caffeine notice headaches when they stop consuming coffee for several days. If this is the case with you, you might want to ease off the coffee more gradually.

**Q. I don't like red meat. I notice that the Lean Cuisine® Lasagna with Meat Sauce contains beef. What can I substitute for it?**

A. Lean Cuisine® has many other frozen dinners that you may substitute for Lasagna with Meat Sauce. Try to find one that contains the same calories, with approximately 15 to 20 percent of the calories coming from fat. Some of the Lean Cuisine® dinners actually have too little fat for my nutritional requirements.

**Q. May I have dinner for lunch and lunch for dinner?**

A. Yes.

**Q. I tend to get a headache when I drink cold water. Can I drink water without it being chilled?**

A. Yes, but you won't get the 123 calories or more thermogenic effect from warming the cold water to core body temperature. Try a more gradual drinking of the cold water. You may have been consuming it too quickly.

**Q. Is it possible to drink too much water?**

A. Certainly. To do so, however, you'd probably have to drink four or five times as much per day as I'm recommending. There are a few ailments that can be negatively affected by large amounts of fluid. If you feel you have a problem, check with your doctor before starting the program.

**Q. Is bottled water better than tap water?**

A. Research shows that bottled water is not always higher quality water than tap water. The decision to drink bottled water or not is usually one of taste. If you dislike the taste of your tap water, then drink your favorite bottled water. But first you might want to try a twist of lemon or lime added to the water from your tap. Some people say it makes a significant difference in

the taste.

**Q. I'm a middle-aged woman who gets black and blue marks on my legs when I diet. Am I doing anything wrong?**

A. I doubt you are doing anything wrong. Such black and blue marks are usually the result of an increased level of estrogen circulating in your body, which weakens the walls of the capillaries and causes them to break under the slightest pressure. When this happens, blood escapes and a bruise occurs. Estrogen is broken down in the liver, and so is fat. When you are dieting, your liver breaks down the fat, leaving a lot more estrogen in the bloodstream.

It may be helpful to supplement your diet with a little extra vitamin C each day to help toughen the walls of the capillaries.

**Q. I'm a 40-year-old woman with a teenage son and daughter. My husband and I both want to lose 10 pounds (4.5 kg) and the children would also like to lose some weight. Can I put the whole family on the program?**

A. It would be great if you could, but you cannot. The number of calories per day is the problem. Teenagers require significantly more calories each day than 1500, which is the highest level. Check with a registered dietician (RD) for appropriate recommendations.

Your teenage son and daughter, however, could follow the Bowflex® exercise routines.

**Q. I'm afraid that I might get large, unfeminine muscles from some of the Bowflex® exercises you recommend in this course. What can I do to prevent this from happening?**

A. You are worrying about large muscles unnecessarily. Building large muscles requires two conditions. First, the individual must have long muscles and short tendons. Second, an abundance of testosterone must be present in the blood stream. Women almost never have either of these conditions.

Under no circumstances could 99.99 percent of American women develop excessively large muscles. Progressive resistance exercise such as with the Bowflex® machine will make your muscles larger—but not excessively large—and larger muscles will make your body firmer and more shapely.

**Q. Why is it so important I perform the Bowflex® exercises with a 4-second count on the lifting and lowering?**

A. Because a slow, smooth 4-second lifting followed by a 4-second lowering involves more muscle fibers more thoroughly than faster speeds of movement. The more completely each involved muscle fiber works simply means you'll get better muscle-building results.

**Q. I'm confused about how to breathe during each Bowflex® exercise?**

A. Let's say your goal is to do 10 repetitions on a specific Bowflex® exercise that is performed in the recommended 4-second lifting and 4-second lowering style. Here are the proper breathing guidelines to follow:

- Breathe normally during the first five repetitions.
- Take shorter, more shallow breaths during the sixth, seventh, and eighth repetitions.
- Emphasize exhalation more than inhalation, especially during the ninth and tenth repetitions. Focus on good form and slow movement.
- Do not hold your breath on any repetition. Practice relaxing your face and neck. Do not grit your teeth. Keep your eyes open and remain alert.

**Q. I'm not as disciplined and patient as I'd like to be. How can I better stay on track with the program?**

A. One suggestion is to team up with a partner. Most people are more motivated and make better progress if they go through the program with a friend. In selecting a training partner, here are several things to keep in mind:

- Your partner should be similar to you in age and condition.
- Your partner should be serious about getting into shape and making a commitment. That commitment means you'll be exercising together one hour, three times per week. Each of your joint training sessions should take approximately 50 minutes: 25 minutes for your workout and 25 minutes supervising your partner's workout.
- Your partner should be someone with whom you'll share a spirit of cooperation, not competition.
- Your partner should not be your spouse, brother,

sister, or other family member. You do not want normal interpersonal problems to interfere with the training.

**Q. Why won't you allow me to do aerobic dancing on my off-days to speed up the loss of body fat?**

A. Because doing so doesn't speed up fat loss. Aerobic dancing—and other activities such as running, swimming, cycling, stair-stepping, and racquetball—do not contribute significantly to the fat-loss process. In fact, when added to proper strength training they can actually retard the reduction of fat.

Fat loss is retarded in two ways. Too much repetitive activity prevents maximum muscle building by using up your recover ability. A well-rested recover ability is necessary for muscle growth. Too much activity—especially if you are on a reduced-calorie diet—causes you to get the blahs and quickly lose your enthusiasm. If this happens, you're sure to break your diet.

The primary purpose of this program is to lose fat in the most effective and most efficient manner. Fat loss is prioritized and maximized by building muscle at the same time. The muscle-building process is optimized by a well-rested recovery ability, which necessitates keeping your strenuous and moderately strenuous activities to a bare minimum.

Once you get your body fat to a low level, you can add other activities—and I encourage you to do so—to your weekly fitness schedule. For now, follow the plan exactly as directed.

**Q. What happens after six weeks? How do I continue the program if I need to lose more weight?**

A. You should repeat the program for as long as it takes you to reach your goal. For example, it took Barry Ozer three six-week sessions—18 weeks—to lose all of his excessive fat, which amounted to 75 pounds (34 kg). There are, however, a few guidelines and modifications to apply.

Repeat the eating plan exactly as before: Men, go back to 1500 calories a day for two weeks. Women, go back to 1200 calories a day for two weeks. Then, descend your calories in the same manner.

Keep your superhydration schedule at the highest level. In other words, sip 1 5/8 gallons (6.2 l) of ice-cold water each day.

## Q & A

Continue your Bowflex® exercise routine at the highest level. Perform the same 10 exercises three times per week. Try to get as strong as you can in each exercise, while always focusing on the 4-second count in both lifting and lowering.

**Q. I'm pleased that I lost the fat I wanted to lose. What do I do to maintain my new body weight?**

A. Once you've lost your excessive fat, your next task is to maintain that status. Here are the adjustments you need to make to your current practices.

**Adhere to a carbohydrate-rich, moderate-calorie eating plan.**

Instead of eating from 1000 to 1500 calories a day, you'll be consuming from 1600 to 2400 calories per day. Maybe you can eat even more after your new body weight has stabilized. Trial-and-error experimentation is a must. Women should start with 1600 calories, and men with 2000 calories per day. Note what happens after a week. If your body weight keeps going down, raise the calories by 100 or 200, depending on how much weight you lost during the last week. Soon, you should reach a level where your body weight stabilizes. That level is your daily calorie requirement. Naturally, you'll be able to consume other foods than those listed in the Bowflex® eating plan. By then, however, you should know the value of being a smart shopper and a wise eater. Read labels. Compare nutritional information. Be conscious of the ideal 60:20:20 ratio for carbohydrates, proteins, and fats.

**Eat smaller meals more frequently.**

You've been limiting your five meals per day to 300 calories if you're a woman, or 500 calories if you're a man. You may now up the calories by 100. What happens if during a single meal you eat more than 400 calories if you're a woman, or 600 calories if you're a man? Don't panic. Simply understand that you will sometimes backslide. Learn to anticipate these urges and take corrective action.

**Drink at least 1 gallon (3.8 l) of cold water each day.**

You should realize by now the benefits of consuming plenty of water each day. Make your water bottle a permanent part of your lifestyle.

**Train on the Bowflex® machine at least twice a week.**

There are two primary differences between maintenance and strength-building routines. First,

for maintenance, you do not have to increase the resistance each week or so. If you can do 100 pounds for 12 repetitions on the leg extension, then keep it on 100 pounds and do not go up to 105 pounds. You can maintain the 100-pound level much easier than you can increase it. Second, you do not need to train three times a week. You can maintain your strength at twice a week.

**Add variety to your Bowflex® routines.**

Now is the time to introduce more variety to your routines by adding some new exercises while removing some old ones. Below are two sample routines.

**Maintenance Routine 1**

1. Seated Hip Abduction
2. Seated Hip Adduction
3. Seated Straight Leg Calf Raise
4. Chest Fly
5. Incline Bench Press
6. Shoulder Pullover
7. Shoulder Shrug
8. Standing Biceps Curl
9. Seated Wrist Curl
10. Seated Wrist Extension

**Maintenance Routine 2**

1. Leg Curl
2. Leg Extension
3. Standing Lateral Shoulder Raise
4. Seated Shoulder Press
5. Rear Deltoid Row
6. Decline Press
7. Reverse Curl
8. Seated Triceps Extension
9. Low Back Extension
10. Abdominal Crunch

Look in your Bowflex Revolution™ Owner's Manual for descriptions of the new exercises.

Be consistent with your Bowflex® machine exercising, healthy eating, and superhydrating—and your accomplishments may well exceed your goals.

## Limited Warranty

### 6-Week Satisfaction Guarantee

We want you to know that the Bowflex Revolution® home gym is a superior product. Your satisfaction is guaranteed. If, for any reason, you are not 100% satisfied with your Bowflex Revolution® home gym, please follow the instructions below to return your merchandise and receive a refund of the purchase price, less shipping and handling.

1. Call a Nautilus Representative at 1-800-605-3369 or write to Nautilus, Inc. at 16400 SE Nautilus Drive, Vancouver, WA 98683 for a Return Authorization Number. Return Authorization will be granted if:
  - a. You purchased your Bowflex Revolution® home gym directly from Nautilus or from a certified Nautilus® dealer; and
  - b. You are calling within 6 weeks of the delivery date of your merchandise.

Returns should be shipped to: Nautilus, 16400 SE Nautilus Drive, Vancouver, WA 98683.

All returned merchandise must be properly packaged in the original boxes and in good condition.

**NOTE: You are responsible for return shipping and for any damage or loss to merchandise that occurs during return shipment. We highly recommend that you insure your shipment.**

3. Please mark all boxes clearly with:
  - Return Authorization Number
  - Your Name
  - Your Address
  - Your Phone Number

Boxes without this information clearly marked on the outside may be refused.

4. Please make copies of your original invoice and put one in each box of merchandise. Your shipment must be received within two weeks from the date the Nautilus Representative issued you your Return Authorization Number.

Refunds may be denied or delayed if these instructions are not completely followed. Satisfaction Guarantee applies only to merchandise purchased by consumers directly from Nautilus, and does not apply to sales made by dealers or distributors.

### What Does This Warranty Cover?

Nautilus warrants to the original purchaser of this Bowflex® product that the equipment is free from defects in materials or workmanship, with the exceptions stated below. This warranty is not transferable or applicable to any person other than the

original purchaser. Tampering with the unit will void the warranty.

### Warranty

- 10 Years on machine and SpiraFlex® resistance packs.

#### Warranty terms may differ outside the USA.

To make this warranty effective, you must completely fill out the Bowflex Revolution® Warranty Registration Card within 30 days of purchase and return it to the address on the Warranty Registration Card.

### Warranties Do Not Cover

- Damage due to use by persons who weigh more than 300 pounds (136 kg).
- Damage due to normal wear and tear.
- Damage due to abuse, accident, failure to follow instructions or warnings in the Owner's Manual, misuse, mishandling, accident or Acts of God (such as floods, tornadoes, power surges, etc.).
- Use in any institutional or commercial settings such as health clubs, schools, or recreation centers.
- Consequential or incidental damage. Some states do not allow the exclusion or limitation of incidental or consequential damages, so the above limitation or exclusion may not apply to you.

### What We Will Repair

During your Warranty Coverage Period, Nautilus will repair any Bowflex® equipment that proves to be defective in materials or workmanship. In the event repair is not possible, Nautilus, Inc., at its option, will either replace your equipment or refund your purchase price, less shipping and handling. Nautilus reserves the right to substitute material of equal or better quality if identical materials are not available at the time of service under this Warranty. The replacement of the product under the terms of the Warranty in no way extends the Warranty period.

### How to Obtain Service

To obtain service for a Bowflex® Fitness Product, contact an authorized Bowflex® Fitness Retailer. You may also contact a Nautilus representative at 800-628-8458 to help you locate a dealer in your area.

### How State Law Applies

This warranty gives you specific legal rights. You may also have other rights, which vary from state to state.



# Bowflex Revolution® Warranty Registration Card

**IMPORTANT! MAIL WITHIN 30 DAYS OF PURCHASE**

**PLEASE PRINT CLEARLY – THANK YOU**

Mr.    2.  Mrs.    3.  Ms.    4.  Miss    Customer ID from Invoice

Name:

Address:  Apt. #:

City:  State:  Zip:

Phone number: (  )  -  EXT.

E-Mail address:

Is this your primary address?  Yes  No

Place of purchase:

Date of purchase:        
M M D D Y Y

Purchaser date of birth:        
M M D D Y Y

Gender:  Male  Female

Marital status:  Married  Single

Including yourself, total number of people living in your household: (Examples: 01, 02, 03 ...)

Would you like to receive additional information on healthy lifestyle products?  Yes  No

Which best describes your family income: (US dollar figures)

- |  |  |  |  |
|--|--|--|--|
| <input type="checkbox"/> Under \$15,000      | <input type="checkbox"/> \$25,000 – \$34,999 | <input type="checkbox"/> \$50,000 – \$74,999 | <input type="checkbox"/> \$100,000 – \$149,999 |
| <input type="checkbox"/> \$15,000 – \$24,999 | <input type="checkbox"/> \$35,000 – \$49,999 | <input type="checkbox"/> \$75,000 – \$99,999 | <input type="checkbox"/> Over \$150,000        |

What other types of exercise equipment do you own?

Did you receive this item as a gift?  Yes  No

Name of original purchaser:

Original purchaser customer ID number:

Thanks for filling out this questionnaire. Your answers are important to us. Please check here  if you would prefer not to obtain information on new and interesting opportunities from other exciting companies.

## What Is Covered

Nautilus, Inc. warrants to the original purchaser of this Bowflex® product that the equipment is free from defects in materials or workmanship, with the exceptions stated below. This warranty is not transferable or applicable to any person other than the original purchaser. Tampering with the unit will void the warranty..

## Warranty Period

- 10 years on machine and Spiraflex® resistance packs.

## Warranties Do Not Cover

- Damage due to use by persons who weigh more than 300 pounds (136 kg).
- Damage due to normal wear and tear..

- Damage due to abuse, accident, failure to follow instructions or warnings, misuse, mishandling, accident or Acts of God (such as floods or power surges).
- Use in any commercial or institutional settings such as health clubs, schools or recreation centers.
- Consequential or incidental damage. Some states do not allow the exclusion or limitation of incidental or consequential damages, so the above limitation or exclusion may not apply to you.

## What We Will Do

During your Warranty Coverage Period, Nautilus will repair any Bowflex® equipment that proves to be defective in materials or workmanship. In the event repair is not possible, Nautilus, Inc., at its option, will

either replace your equipment or refund your purchase price, less shipping and handling.

## How To Obtain Service

To obtain service for a Bowflex® Fitness Product, contact an authorized Bowflex® Fitness Retailer. You may also contact a Nautilus representative at 800-628-8458 to help you locate a dealer in your area.

## How State Law Applies

This warranty gives you specific legal rights. You may also have other rights which vary from state to state.



**Please fold over and tape before mailing**



**Please fold over and tape before mailing**

**Place  
Stamp  
Here**

**Bowflex Revolution®  
16400 SE Nautilus Drive  
Vancouver, WA 98683**

# Important Contact Numbers

If you need assistance, please have both the serial number of your machine and the date of purchase available when you contact the appropriate Nautilus office listed below. To locate the serial number label on your machine, refer to the Safety Warning Labels information in this manual.

Please record the following information for future reference.

**Serial Number**

**Date of Purchase**

## OFFICES IN THE UNITED STATES:

E-mail: [customerservice@nautilus.com](mailto:customerservice@nautilus.com)

- TECHNICAL/CUSTOMER SERVICE  
Nautilus, Inc.  
World Headquarters  
16400 SE Nautilus Drive  
Vancouver, Washington, USA 98683  
Phone: 800-NAUTILUS (800-628-8458)  
Email: [customerservice@nautilus.com](mailto:customerservice@nautilus.com)  
Fax: 877-686-6466
- CORPORATE HEADQUARTERS  
Nautilus, Inc.  
World Headquarters  
16400 SE Nautilus Drive  
Vancouver, Washington, USA 98683  
Phone: 800-NAUTILUS (800-628-8458)

## INTERNATIONAL:

For technical assistance and a list of distributors in your area, please call or fax one of the following numbers.

- INTERNATIONAL CUSTOMER SERVICE  
Nautilus International S.A.  
Rue Jean Prouvé 6  
1762 Givisiez / Switzerland  
Tel: + 41-26-460-77-77  
Fax: + 41-26-460-77-70  
Email: [technics@nautilus.com](mailto:technics@nautilus.com)

## BUSINESS OFFICES:

- SWITZERLAND OFFICE  
Nautilus Switzerland S.A.  
Tel: + 41-26-460-77-66  
Fax: + 41-26-460-77-60
- GERMANY and AUSTRIA OFFICE  
Nautilus GmbH  
Tel: +49-2203-20-20-0  
Fax: +49-2203-20-20-4545
- ITALY OFFICE  
Nautilus Italy s.r.l.  
Tel: +39-051-664-6201  
Fax: +39-051-664-7461
- UNITED KINGDOM OFFICE  
Nautilus UK Ltd.  
Tel: +44-1908-267-345  
Fax: +44-1908-267-346
- CHINA OFFICE  
Nautilus Representative Office  
Tel: +86-21-523-707-00  
Fax: +86-21-523-707-09

POWERED BY  
**SPIRAFLEX**



 **BOWFLEX**  
**REVOLUTION**

©2007 Nautilus, Inc. All rights reserved. Nautilus, Bowflex, the Bowflex logo, Bowflex Revolution and Power Rod are either registered trademarks or trademarks of Nautilus, Inc. All other trademarks are owned by their respective companies.

Nautilus, Inc., World Headquarters, 16400 SE Nautilus Drive, Vancouver, Washington, USA 98683 1-800-NAUTILUS www.nautilus.com

Printed in USA

Download from [www.Somanuals.com](http://www.Somanuals.com). All Manuals Search And Download.

## Free Manuals Download Website

<http://myh66.com>

<http://usermanuals.us>

<http://www.somanuals.com>

<http://www.4manuals.cc>

<http://www.manual-lib.com>

<http://www.404manual.com>

<http://www.luxmanual.com>

<http://aubethermostatmanual.com>

Golf course search by state

<http://golfingnear.com>

Email search by domain

<http://emailbydomain.com>

Auto manuals search

<http://auto.somanuals.com>

TV manuals search

<http://tv.somanuals.com>