

XLA 3200



Security Systems

- EN | Installation Manual
Line Array Loudspeakers
- FR | Manuel d'installation
Enceintes colonnes
- DE | Installationshandbuch
Line-Array-Lautsprecher
- ES | Manual de instalación
Altavoces de línea vertical
- NL | Installatiehandleiding
Line Array Luidsprekers
- IT | Manuale d'installazione
Colonne sonore
- PT | Manual de instalação
Coluna linear de altifalantes

BOSCH

	Installation Manual	
EN	Line Array Loudspeakers	5
	Manuel d'installation	
FR	Enceintes colonnes	27
	Installationshandbuch	
DE	Line-Array-Lautsprecher	49
	Manual de instalación	
ES	Altavoces de línea vertical	71
	Installatiehandleiding	
NL	Line Array Luidsprekers	93
	Manuale d'installazione	
IT	Colonne sonore	115
	Manual de instalação	
PT	Coluna linear de altifalantes	137

Contents	Page
Installation guide (fig 1 - fig 17)	6
Line/Loudspeaker supervision board mounting (optional) (fig A1 - fig A5)	8
Additional bracket mounting (optional) (fig B1 - fig B5)	8
Foorstand mounting (optional) (fig C1 - fig C3).....	8
Listening area and related mounting height LBC 3200/00	9
Listening area and related mounting height LBC 3201/00.....	11
Listening area and related mounting height LBC 3210/00.....	14
Technical data LBC 3200/00.....	17
Technical data LBC 3201/00	20
Technical data LBC 3210/00	23

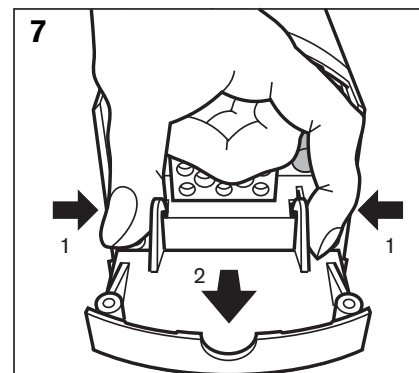
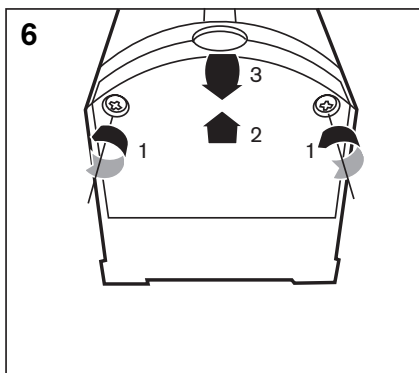
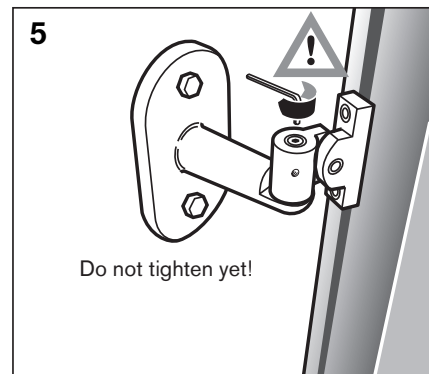
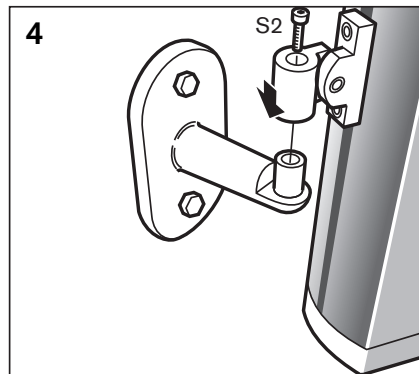
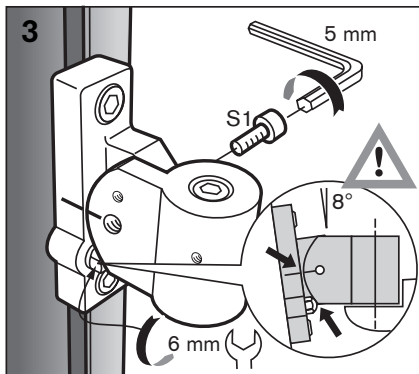
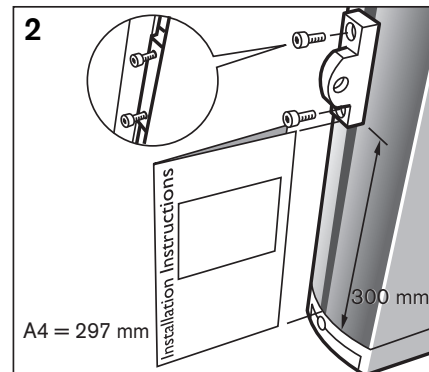
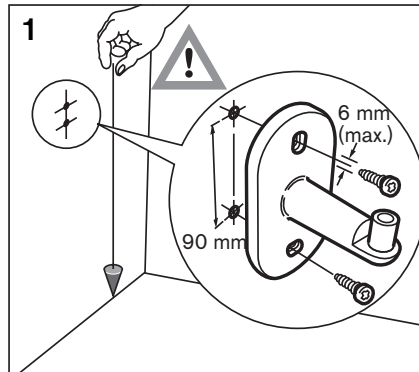
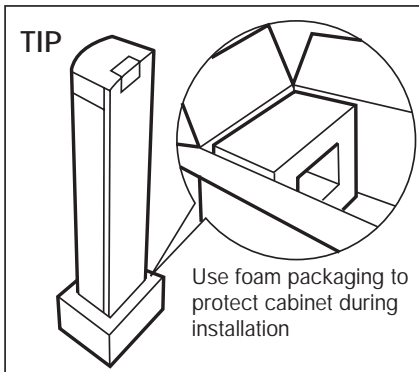
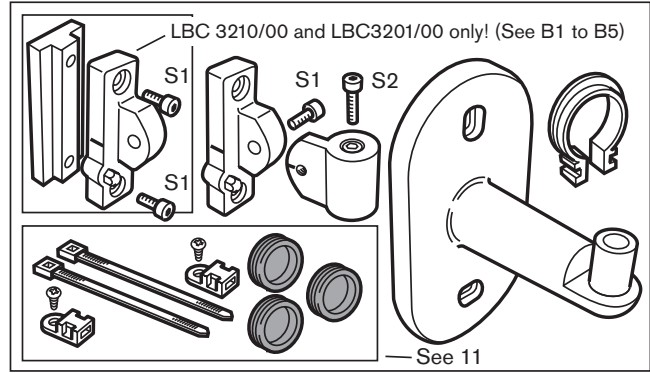
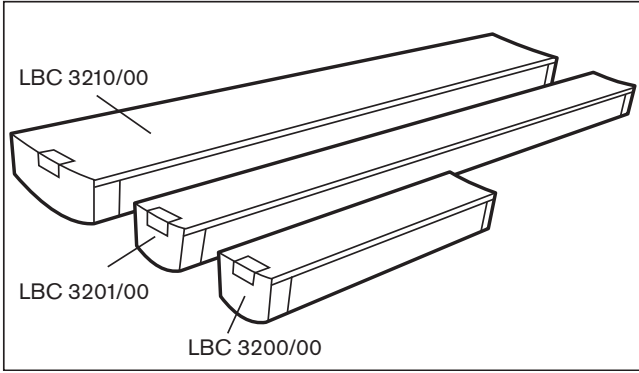

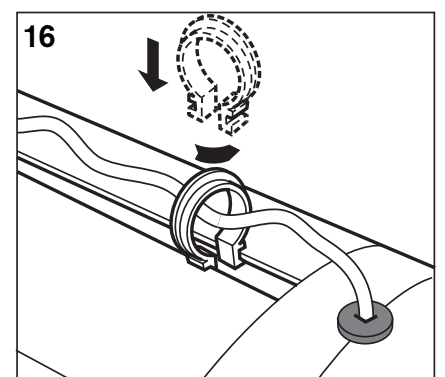
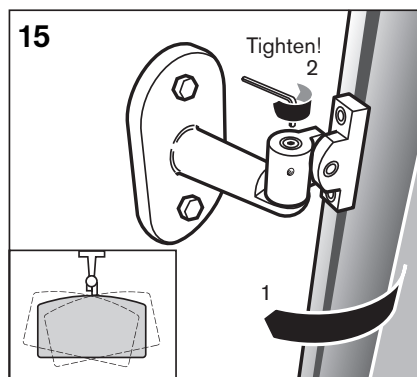
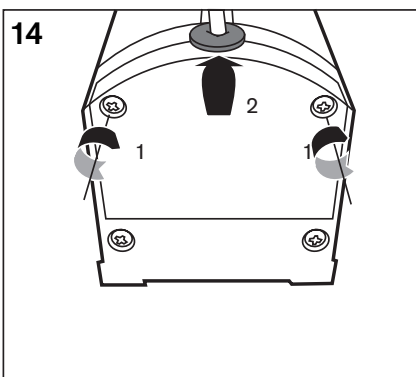
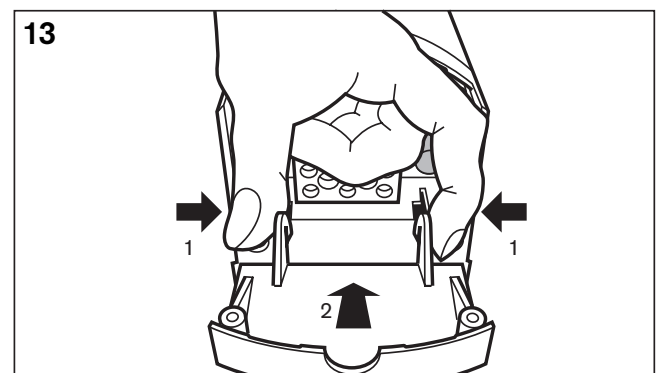
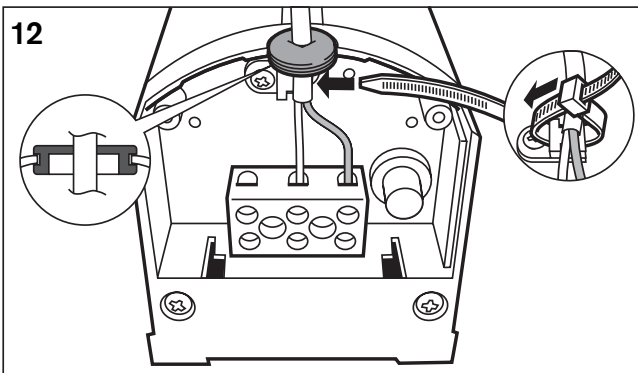
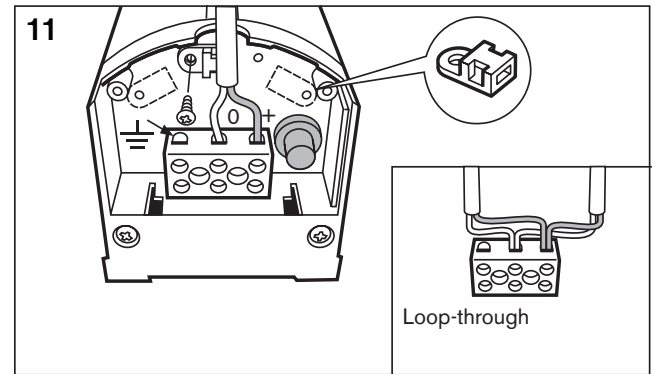
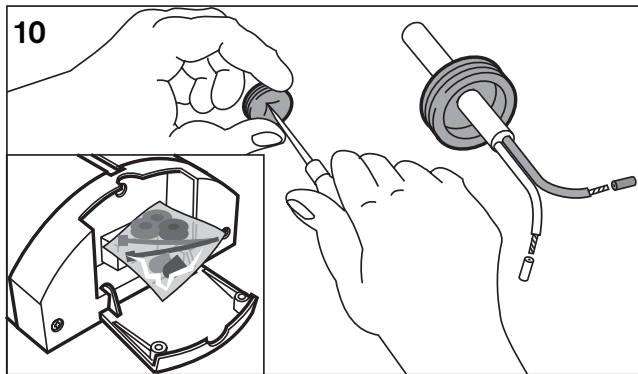
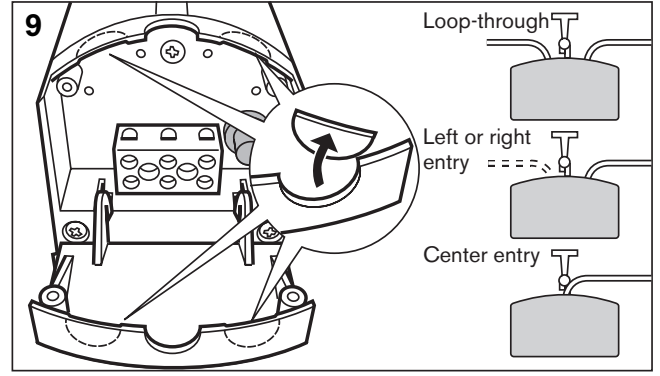
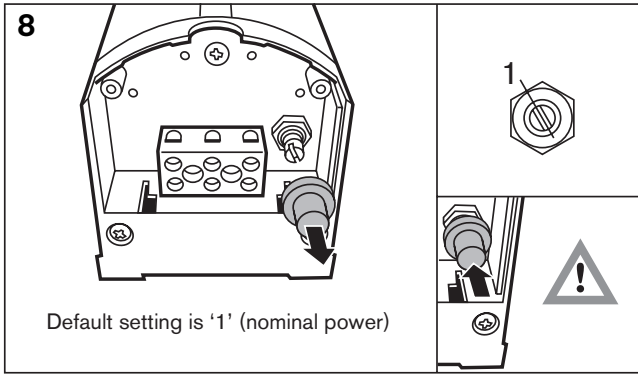

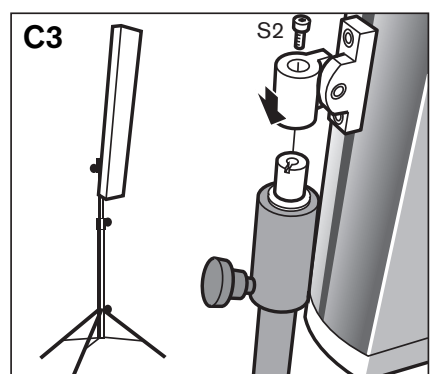
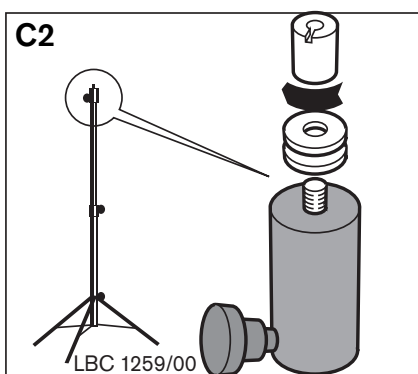
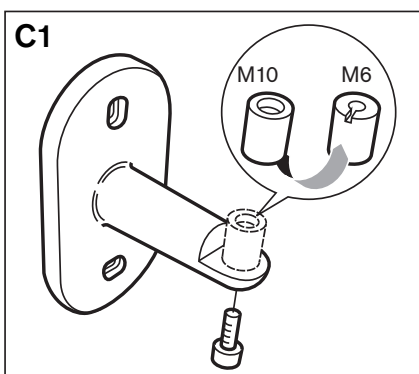
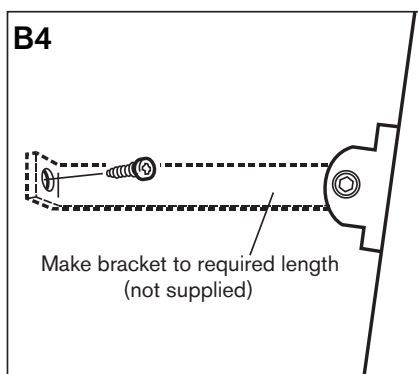
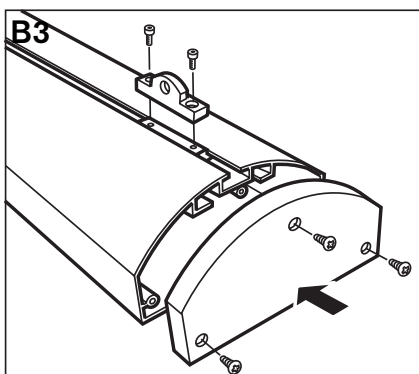
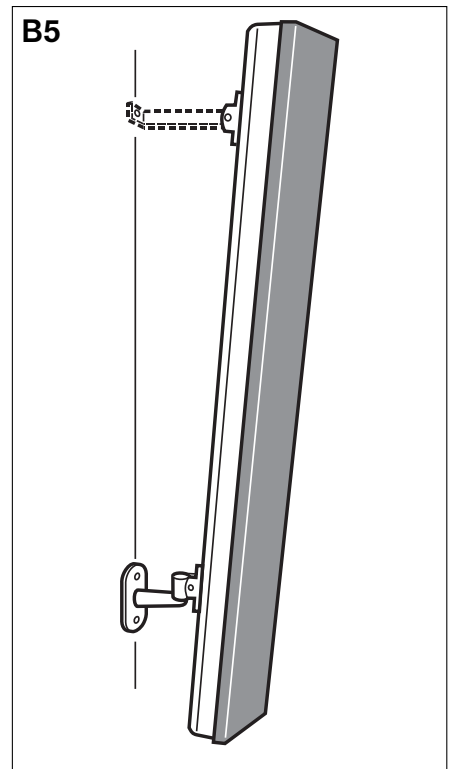
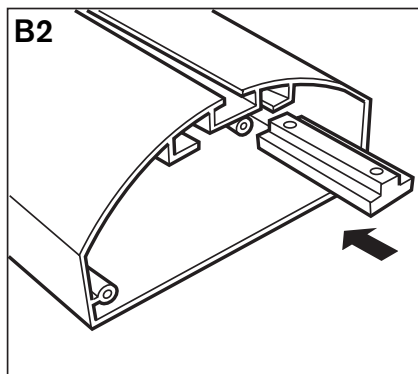
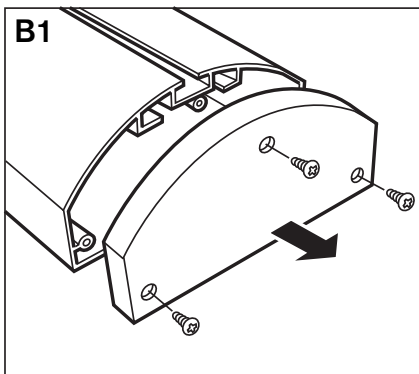
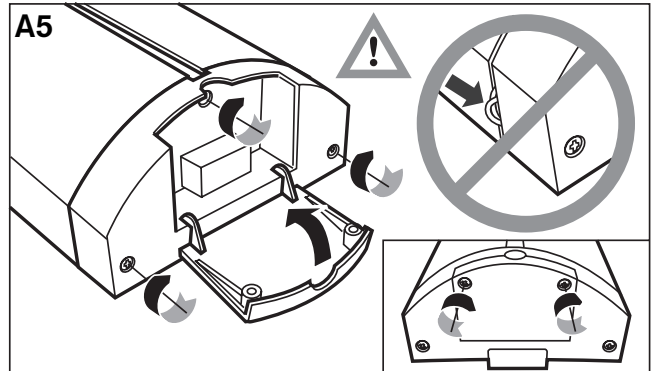
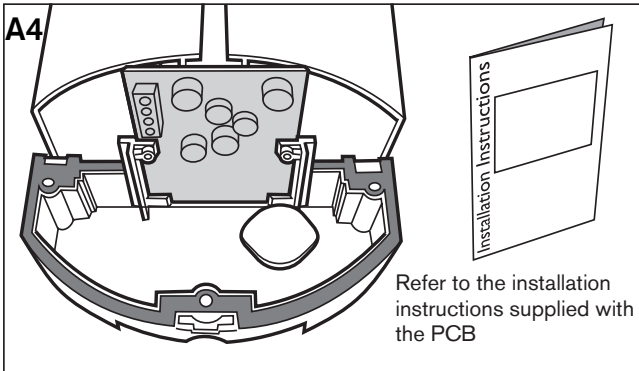
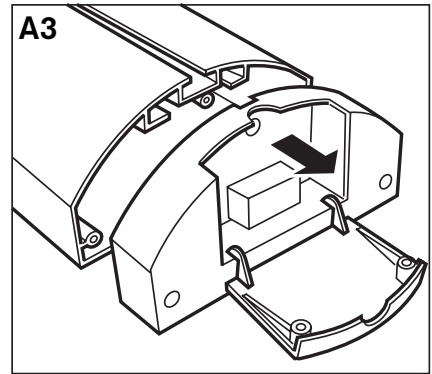
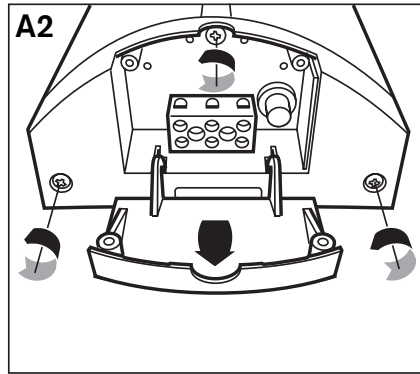
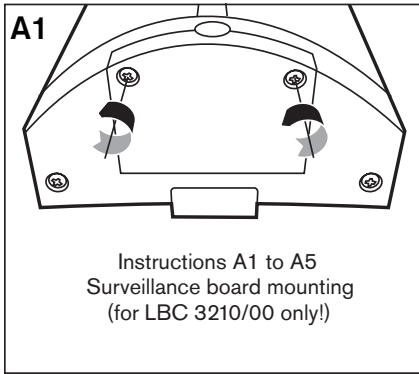

Listening area and related mounting height for XLA3200/00

Determining mounting height and angle for the LBC3200 loudspeaker array:

1. Determine the dimensions of the desired 'listening area' (a horizontal plane at the level of the listeners' ears – refer to the dashed line in figure 1).
2. Determine the angle at which the loudspeaker array is to be mounted. The array is designed to beam sound just above the listeners' heads, and it is recommended not to exceed an angle of 6°. There are two approaches, each with specific pros and cons.
 - Approach 1: Maximized listening area
When a large listening area is desired, an angle of round 3° is recommended (see figure 1). Note that when walking away from the loudspeaker array, the sound pressure level will decrease by an amount that depends on the room reverberation. To hear high tones clearly, the listener should be able to see the loudspeaker array.
 - Approach 2: Minimized sound pressure level variation
When less sound pressure level variation is desired, an angle of 5° is recommended. Note that this reduces the size of the total listening area compared to approach 1, and that the space very close to the loudspeaker array ('A' in figure 2) is not part of the listening area. Diagram 1 shows the relationship between 'A' and the mounting height of the loudspeaker array when using a 5° installation angle.
3. After selecting the most appropriate approach (mounting angle), the mounting height of the loudspeaker is determined by focusing the 0°-axis of the loudspeaker array to the desired position just above ear level of the furthest listener. This can be adjusted by mounting the loudspeaker higher or lower on the wall.

Now you can mount the loudspeaker array for optimal acoustic performance.

Installation questions and answers:

- **May I install the LBC3200 loudspeaker array the same as LBC3210 or LBC3201?**
This loudspeaker array is designed for small and medium indoor environments. The optimal acoustical performance of this loudspeaker array is obtained by beaming the sound just above the listeners' heads. When this loudspeaker array is mounted as the LBC3210 or LBC3201, a very small listening area results. This is also the reason for not using an angle greater than 6°.

- **If I cannot see the loudspeaker array, does it mean that I cannot hear high tones?**

You can compare high tones with light. When something is between you and the light source, you do not see the light source with its full power. We call this shadow. We have the same situation with high tones. When a lot of people are sitting between you and the loudspeaker, you are sitting in the sound shadow. We experience that as a reduction of high tones.

Background information:

- Because of the many installing angles it is difficult to give a defined shape of the radiated sound from the loudspeaker array.
- By installing the loudspeaker array at a small angle, a (very) large listening area can be reached. Depending of the amount of reverberation in the room and the sound shadow (people or objects in front of a listener who are blocking the direct sound source) the speech intelligibility on a far position may be low. In these situations, it is better to use more loudspeaker arrays to split the listening area.
- When you move further than the maximum position of the listening area (more than the maximum distance from the loudspeaker array), only the sound pressure level will decrease. There is almost no tone height variation. The decreasing of sound pressure level depends strongly on the reverberation of the room.
- When you are too close to the loudspeaker array (less than the minimum distance from the loudspeaker array) and are using the 5° approach a decline of the high tones will very soon occur.
- Because the loudspeakers are designed to beam the sound just above the listeners' heads, it is better not to mount the loudspeakers too high above the listening area.
- To determine exactly where the edges of the listening area are in your situation, you have to carry out a practical test at the location where the loudspeaker array is installed. This is a job for an experienced listener with well-trained ears. To do so, put pink noise through the loudspeaker array. It is better to reduce the lower tones for this test, as they do not contribute to speech intelligibility. Walk around in the listening area and listen to the high tones. The places where the high tones decreases rapidly are the edges of the listening area.

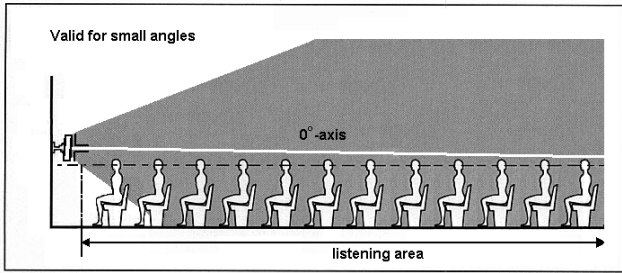

Figure 1 side view of loudspeaker array radiation mounted to the wall with a small angle

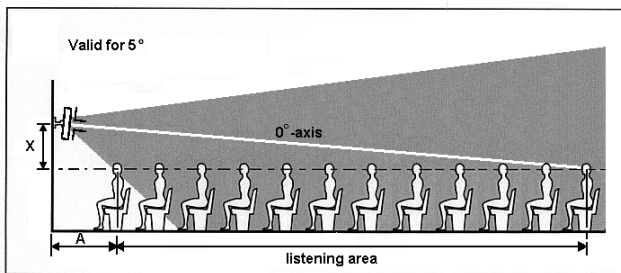

Figure 2: side view of loudspeaker array radiation mounted to the wall with a 5° angle

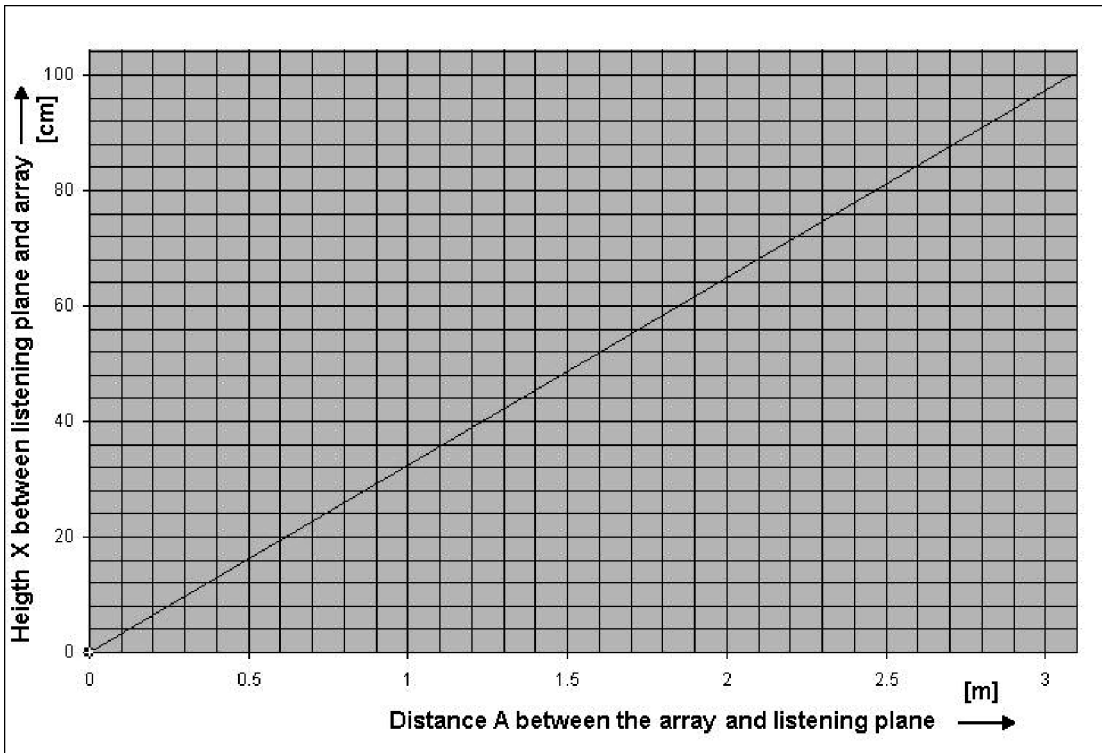

Diagram 1: relation between listening area distance and loudspeaker array

Listening area and related mounting height for XLA3201/00

How to use these mounting method:

1. Determine the dimensions of the desired 'listening area' (a horizontal plane at the level of the listeners' ears – refer to the dashed line in figure 1).
2. Measure the maximum distance from loudspeaker array to the last listener in the listening area (corresponding to 'B' in figures 1, 2 and 3).
3. Refer to diagram 1, and trace upwards from the maximum distance on the horizontal axis. From the vertical intersection with diagonal B-line, you go horizontal to the vertical axis. The X-value (height of loudspeaker array mounting bracket above the listening plane, 'X' in figure 1) is standing on this axis. The horizontal intersections with other diagonal lines provide information about the dimensions of the listening area. These numbers are related to figures 2 and 3 (see also example below).
4. Figure 2 shows the 1kHz octave shape radiated by the loudspeaker array and figure 3 shows the 4kHz octave shape radiation. The listening area with the optimal acoustic performance is in these shapes. Ensure the 4kHz shape with the dimensions obtained using diagram 1 adequately covers the desired listening area.
5. If the desired listening area is covered by the 4kHz shape, the X-value on the vertical axis show at what height the loudspeaker array must be mounted above the listening plane. Note that the loudspeaker array must be mounted at an angle of 8° at the chosen height!

Now you can mount the loudspeaker array for optimal acoustic performance.

Example:

The maximum distance from loudspeaker array to last listener is 15m. Tracing upwards from the 15m point on the horizontal axis of diagram 1 to the diagonal B-line and then sideways to the vertical axis, the intersections with the other diagonal lines provide dimensions of the listening planes. In this example:

F-line (listening plane side length of 4kHz) = 11.1m

C-line (listening plane length) = 11m

E-line (half width listening plane of 4kHz) = 9.3m

A-line (minimum distance to listening plane) = 3.9m

On the vertical axis, the X-value (the height between the listening plane and loudspeaker array mounting bracket) is 1.8m.

Installation questions and answers:

- **The desired listening area is too large and does not fit in the 4kHz shape.**
Try another loudspeaker array mounting height or use more loudspeaker arrays to get a larger listening area.
- **Why use an angle of 8° for the loudspeaker array?**
The radiated shapes shown in figures 2 and 3 with the dimensions in diagram 1 are only valid when the loudspeaker array is mounted at an angle of 8°. Only this situation provides constant sound pressure level and frequency response (constant directivity) in the listening area.
- **Can I use the loudspeaker array with another angle?**
You can use the loudspeaker arrays also with another angle but you will not get the optimum acoustic performance. For example, greater sound pressure level variation will be audible in the listening area. The values in diagram 1 are not valid for other angles. It is recommended never to use an angle greater than 8°.
- **The loudspeaker array cannot be mounted as high as desired.**
If not the height can be reached by limitation of the ceiling for example, use an angle of less than 8°. Focus the 0°-axis of the loudspeaker array to the desired maximum position (see figure 4). Note that the table in diagram 1 and shapes in figures 2 and 3 are not valid for this situation. Check in the listening area if the speech intelligibility is acceptable.

Background information:

- The shapes are defined in an anechoic environment. In these shapes at anechoic conditions, you have a maximum of 6dB sound pressure variation and much less perceived frequency response variation. In areas with normal or high reverberations, less sound pressure level variation take place and the size of shapes will be bigger. The perceived frequency response in this shape will then be almost constant.
- When you go further then the maximum position of the listening area (beyond the maximum distance from the loudspeaker array) only the sound pressure level will decrease. There is almost no tone height variation. The decrease in sound pressure level depends strongly on the reverberation of the room.
- When you move too close to the loudspeaker arrays (less than the minimum distance from the loudspeaker array) a lack of high tones will very soon occur.

- Depending of the amount of reverberation in the room and the sound shadow (people or objects in front of a listener who block the direct sound source), the speech intelligibility at the furthest positions may be low. In these situations, it is better to use more loudspeaker arrays to split the listening area.
- The side lines of the shapes of figure 2 and 3 are the -6dB points related to the sound pressure level on the 0° -axis.
- To get the best speech intelligibility, define a listening area where the 4kHz octave shape covers the whole area.
- To determine exactly where the edges of the listening area are in your situation, you have to carry out a practical test at the location where the loudspeaker array is installed. This is a job for an experienced listener with well-trained ears. To do so, put pink noise through the loudspeaker array. It is better to reduce the lower tones for this test, as they do not contribute to speech intelligibility. Walk around in the listening area and listen to the high tones. The places where the high tones decreases rapidly are the edges of the listening area.

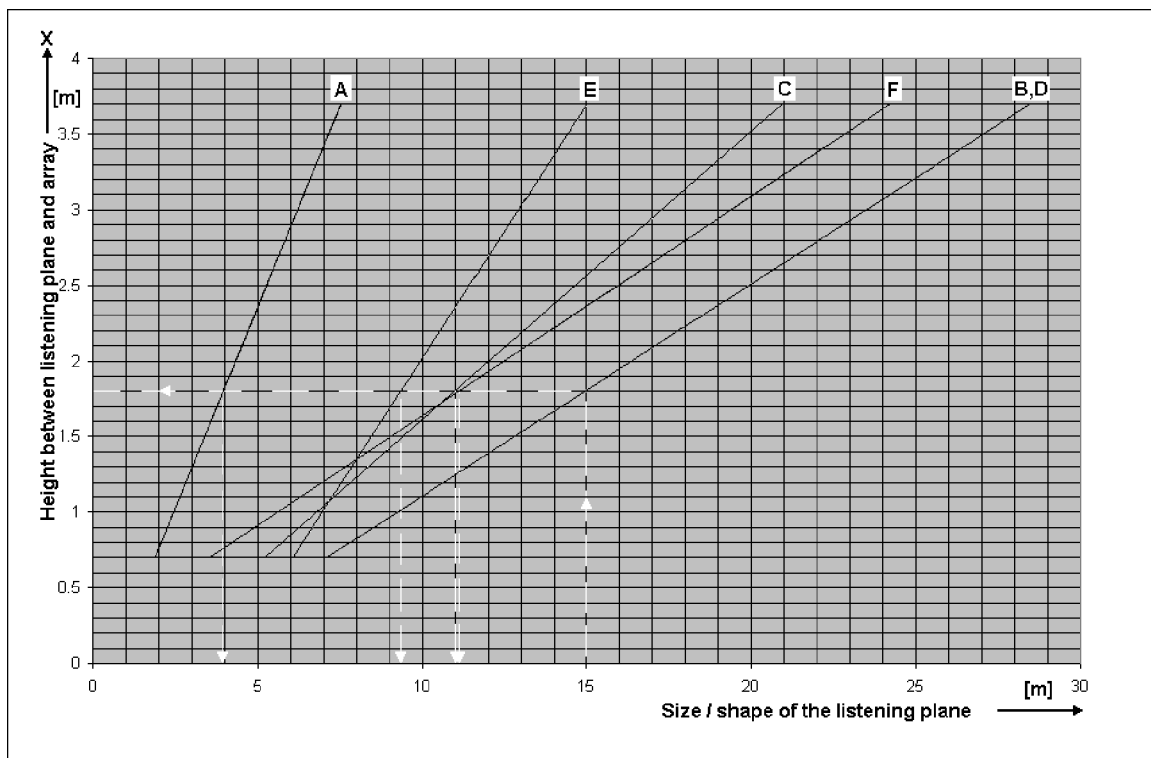

Diagram 1: relation between listening area and loudspeaker array mounting height

Diagonal line meanings

B-line: maximum distance from loudspeaker array to last listener.

D-line: half-width listening plane at 1kHz

F-line: listening plane side length at 4kHz

C-line: listening plane length

E-line: half-width listening plane at 4kHz

A-line: minimum distance to listening plane

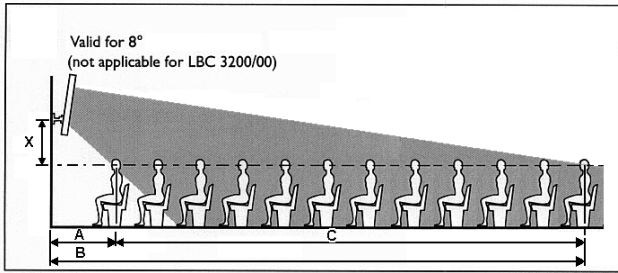

Figure 1: side view of loudspeaker array radiation and listening plane

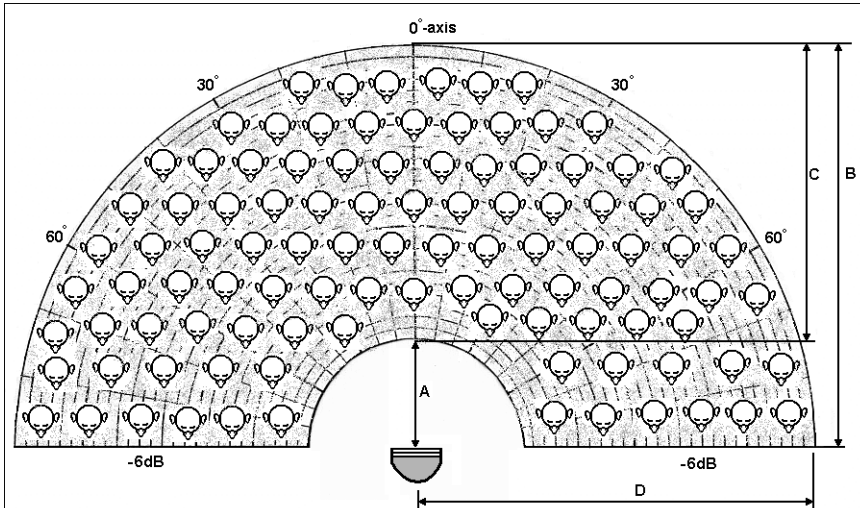

Figure 2: 1kHz octave shape of the loudspeaker array

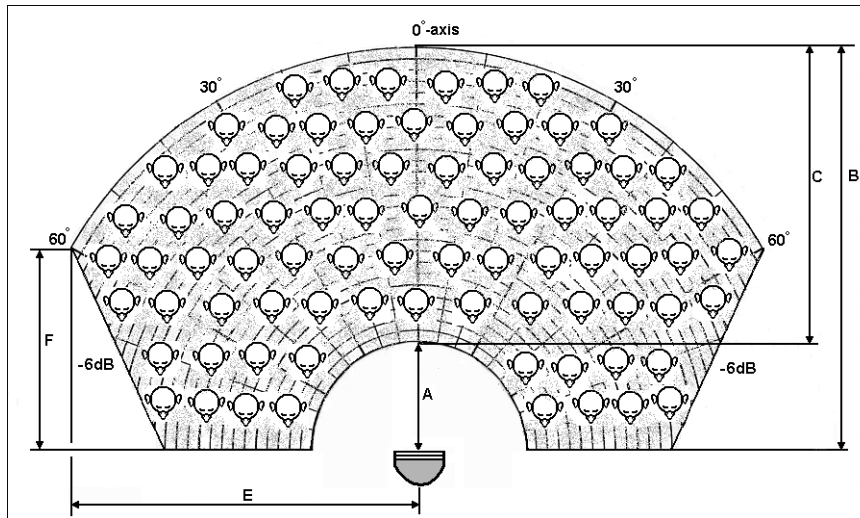

Figure 3: 4kHz octave shape of the loudspeaker array

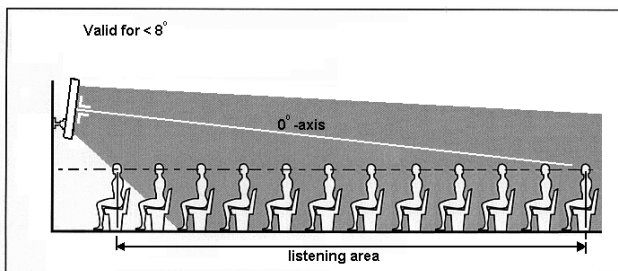

Figure 4: Focus the 0°-axis of the loudspeaker array to the maximum position

Listening area and related mounting height for XLA3210/00

How to use these mounting method:

1. Determine the dimensions of the desired 'listening area' (a horizontal plane at the level of the listeners' ears – refer to the dashed line in figure 1).
2. Measure the maximum distance from loudspeaker array to the last listener in the listening area (corresponding to 'B' in figures 1, 2 and 3).
3. Refer to diagram 1, and trace upwards from the maximum distance on the horizontal axis. From the vertical intersection with diagonal B-line, you go horizontal to the vertical axis. The X-value (height of loudspeaker array mounting bracket above the listening plane, 'X' in figure 1) is standing on this axis. The horizontal intersections with other diagonal lines provide information about the dimensions of the listening area. These numbers are related to figures 2 and 3 (see also example below).
4. Figure 2 shows the 1kHz octave shape radiated by the loudspeaker array and figure 3 shows the 4kHz octave shape radiation. The listening area with the optimal acoustic performance is in these shapes. Ensure the 4kHz shape with the dimensions obtained using diagram 1 adequately covers the desired listening area.
5. If the desired listening area is covered by the 4kHz shape, the X-value on the vertical axis show at what height the loudspeaker array must be mounted above the listening plane. Note that the loudspeaker array must be mounted at an angle of 8° at the chosen height!

Now you can mount the loudspeaker array for optimal acoustic performance.

Diagram example:

The maximum distance from loudspeaker array to last listener is 15m. Tracing upwards from the 15m point on the horizontal axis of diagram 1 to the diagonal B-line and then sideways to the vertical axis, the intersections with the other diagonal lines provide dimensions of the listening planes. In this example:

F-line (listening plane side length of 4kHz) = 12.2m

C-line (listening plane length) = 11m

E-line (half width listening plane of 4kHz) = 8.6m

A-line (minimum distance to listening plane) = 3.9m

On the vertical axis, the X-value (the height between the listening plane and loudspeaker array mounting bracket) is 1.8m.

Installation questions and answers:

- **The desired listening area is too large and does not fit in the 4kHz shape.**
Try another loudspeaker array mounting height or use more loudspeaker arrays to get a larger listening area.
- **Why use an angle of 8° for the loudspeaker array?**
The radiated shapes shown in figures 2 and 3 with the dimensions in diagram 1 are only valid when the loudspeaker array is mounted at an angle of 8°. Only this situation provides constant sound pressure level and frequency response (constant directivity) in the listening area.
- **Can I use the loudspeaker array with another angle?**
You can use the loudspeaker arrays also with another angle but you will not get the optimum acoustic performance. For example, greater sound pressure level variation will be audible in the listening area. The values in diagram 1 are not valid for other angles. It is recommended never to use an angle greater than 8°.
- **The loudspeaker array cannot be mounted as high as desired.**
If not the height can be reached by limitation of the ceiling for example, use an angle of less than 8°. Focus the 0°-axis of the loudspeaker array to the desired maximum position (see figure 4). Note that the table in diagram 1 and shapes in figures 2 and 3 are not valid for this situation. Check in the listening area if the speech intelligibility is acceptable, as messages must be audible.

Background information:

- The shapes are defined in an anechoic environment. In these shapes at anechoic conditions, you have a maximum of 6dB sound pressure variation and much less perceived frequency response variation. In areas with normal or high reverberations, less sound pressure level variation take place and the size of shapes will be bigger. The perceived frequency response in this shape will then be almost constant.
- When you go further then the maximum position of the listening area (beyond the maximum distance from the loudspeaker array) only the sound pressure level will decrease. There is almost no tone height variation. The decrease in sound pressure level depends strongly on the reverberation of the room.
- When you move too close to the loudspeaker arrays (less than the minimum distance from the loudspeaker array) a lack of high tones will very soon occur.
- Depending of the amount of reverberation in the room and the sound shadow (people or objects in

front of a listener who block the direct sound source), the speech intelligibility at the furthest positions may be low. In these situations, it is better use more loudspeaker arrays to split the listening area.

- The side lines of the shapes of figure 2 and 3 are the -6dB points related to the sound pressure level on the 0°-axis.
- To get the best speech intelligibility, define a listening area where the 4kHz octave shape covers the whole area.

To determine exactly where the edges of the listening area are in your situation, you have to carry out a practical test at the location where the loudspeaker array is installed. This is a job for an experienced listener with well-trained ears. To do so, put pink noise through the loudspeaker array. It is better to reduce the lower tones for this test, as they do not contribute to speech intelligibility. Walk around in the listening area and listen to the high tones. The places where the high tones decreases rapidly are the edges of the listening area.

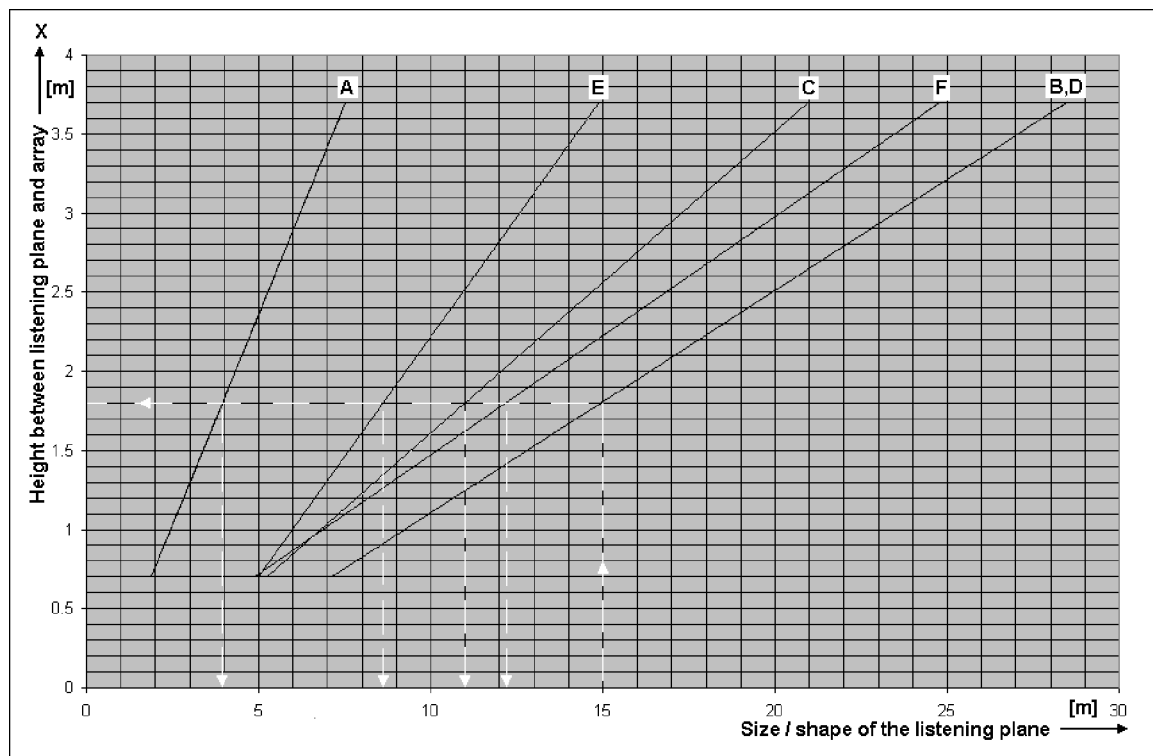

Diagram 1: relation between listening area and loudspeaker array mounting height

Line meaning

B-line: maximum distance from loudspeaker array to last listener.

D-line: half-width listening plane at 1kHz

F-line: listening plane side length at 4kHz

C-line: listening plane length

E-line: half-width listening plane at 4kHz

A-line: minimum distance to listening plane

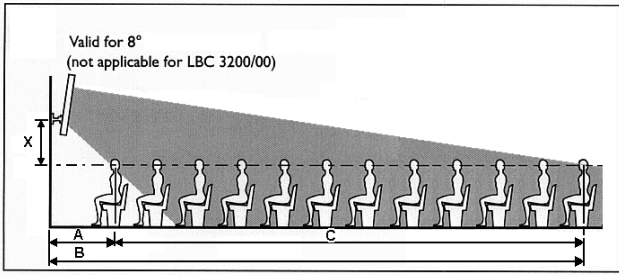

Figure 1: side view of loudspeaker array radiation and listening plane

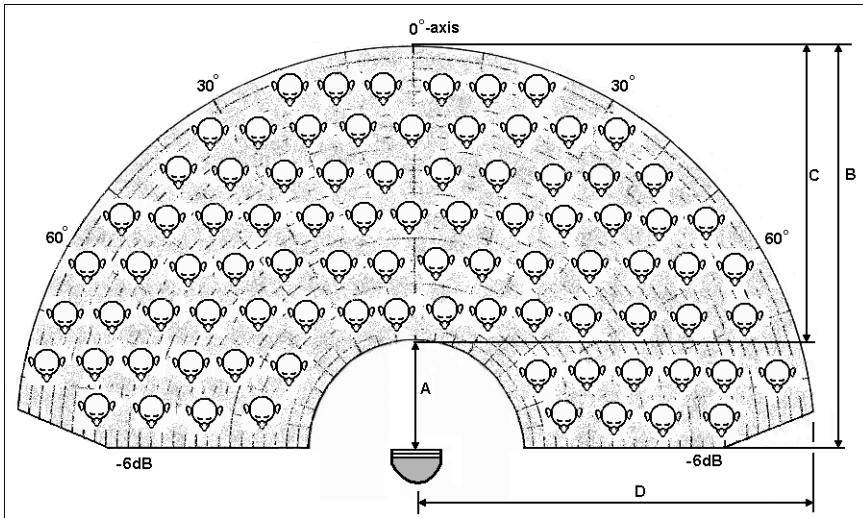

Figure 2: 1kHz octave shape of the loudspeaker array

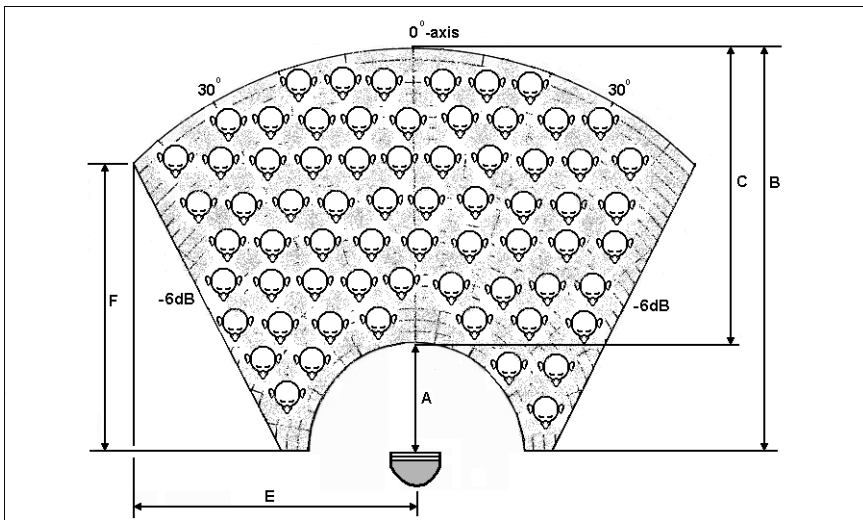

Figure 3: 4kHz octave shape of the loudspeaker array

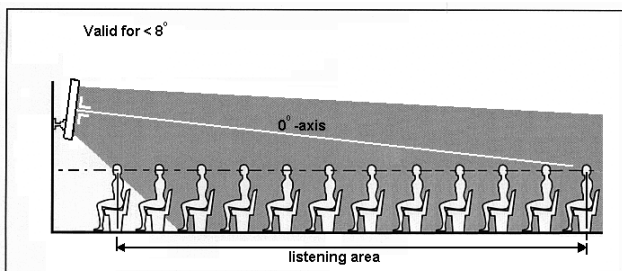
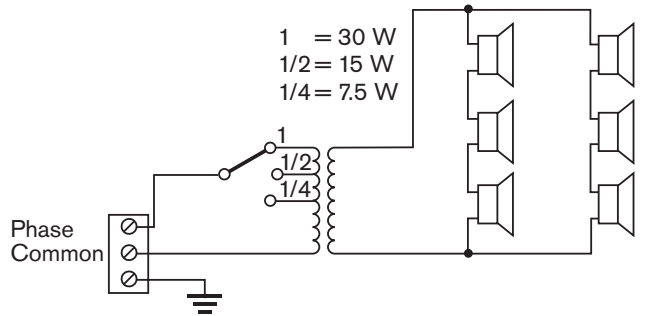
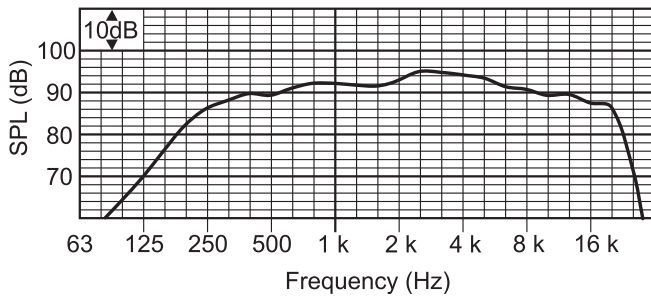

Figure 4: Focus the 0°-axis of the loudspeaker array to the maximum position

TECHNICAL PERFORMANCE DATA

LBC 3200/00

Maximum power	45 W
Rated power	30 W (30-15-7.5 W)
Sound pressure level at	
30 W/1 W (at 1 kHz, 1 m)	106 dB/91 dB (SPL)
Effective frequency range (-10 dB)	190 Hz to 18 kHz
Opening angle	
(at 1 kHz/4 kHz, -6 dB)	
Horizontal	220° /130°
Vertical	70° /18°
Rated input voltage	100 V
Rated impedance	333 ohm
Ambient temperature range	-25°C to +55°C
Safety	according to EN 60065
Connection	screw terminal block
Dimensions (H x W x D)	600 x 80 x 90 mm
Colour	silver
Weight	3 kg



LBC 3200/00

Octave band (Hz)	250	500	1 k	2 k	4 k	8 k
SPL 1.1	87	89	91	93	93	89
SPL max.	102	104	106	108	108	104
Q-factor	1.3	2.2	4.5	11.6	25.7	58.9
Hor. Angle (deg)	360	360	220	190	130	100
Vert. Angle (deg)	360	120	70	32	18	10

Horizontal

Vertical

LBC 3200/00
250Hz horizontal

LBC 3200/00
250Hz vertical

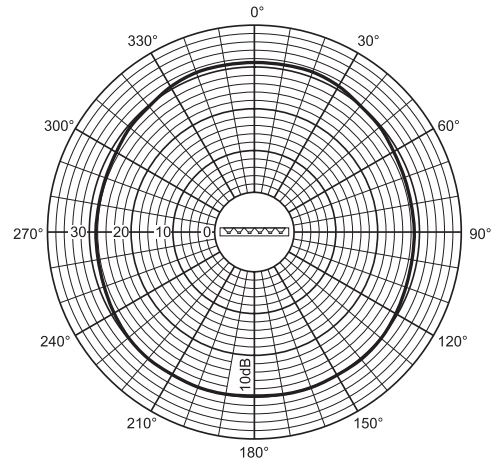
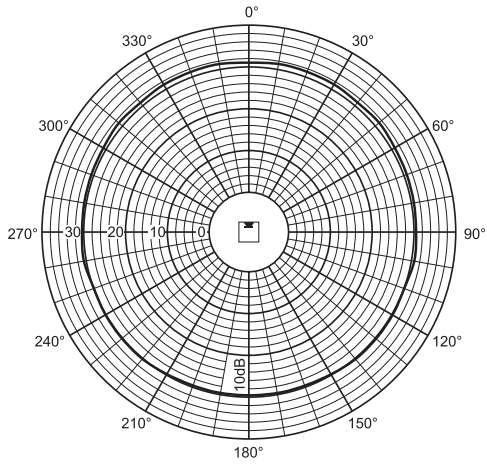

LBC 3200/00
500Hz horizontal

LBC 3200/00
500Hz vertical

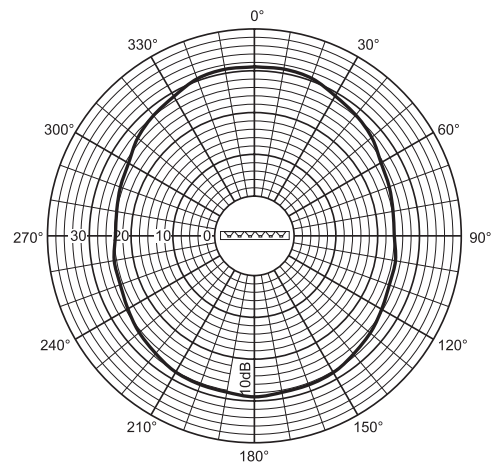
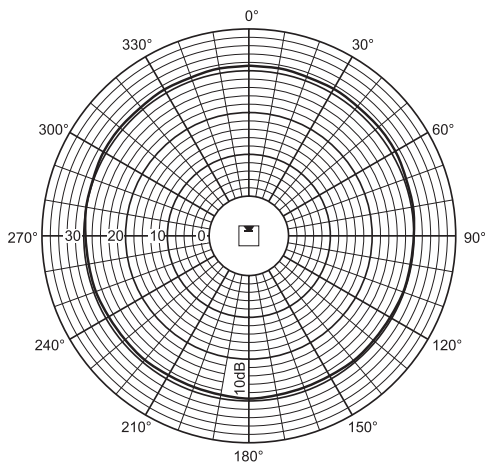

LBC 3200/00
1kHz horizontal

LBC 3200/00
1kHz vertical

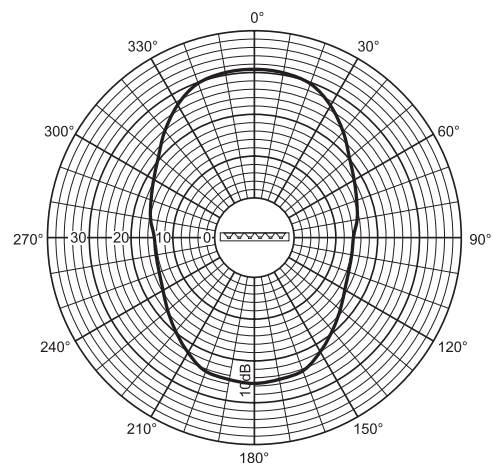
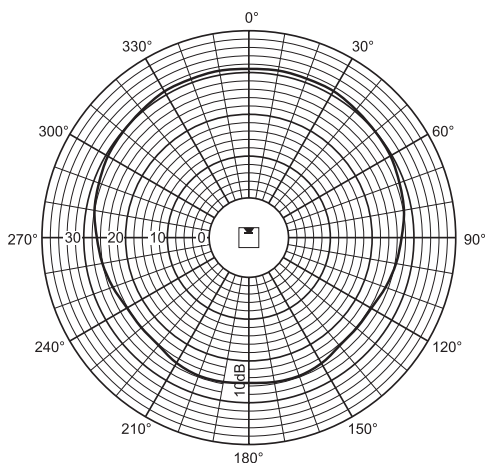

Horizontal

Vertical

LBC 3200/00
2kHz horizontal

LBC 3200/00
2kHz vertical

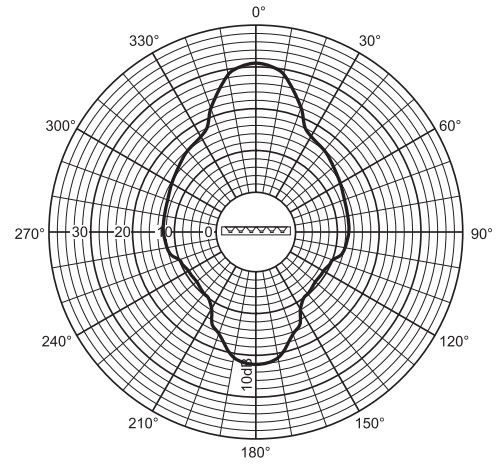
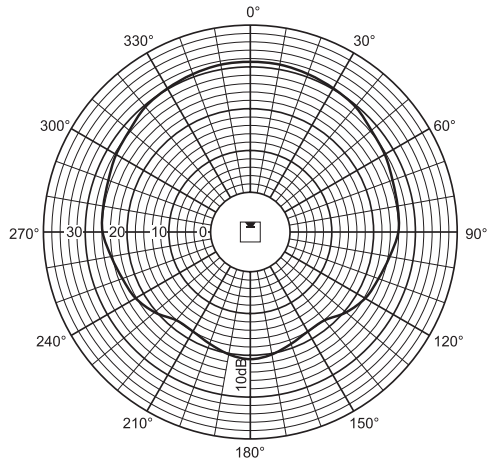

LBC 3200/00
4kHz horizontal

LBC 3200/00
4kHz vertical

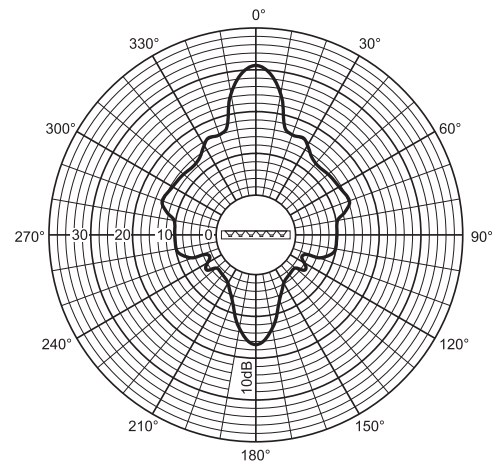
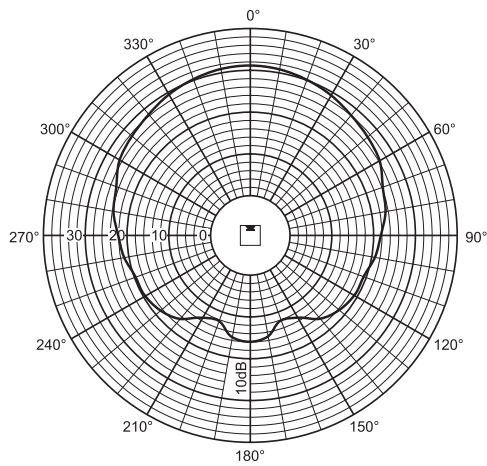

LBC 3200/00
8kHz horizontal

LBC 3200/00
8kHz vertical

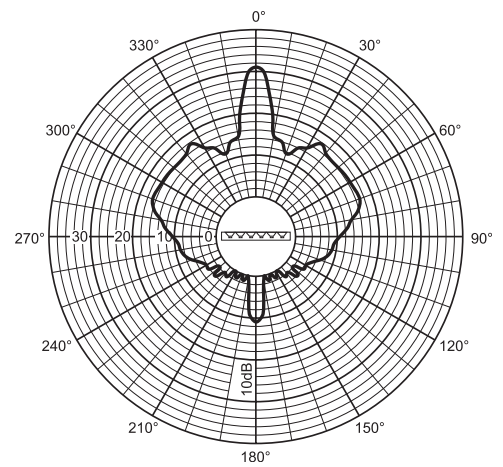
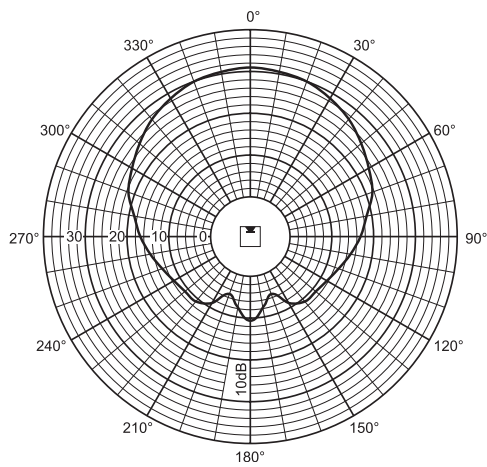

TECHNICAL PERFORMANCE DATA

LBC 3201/00

Maximum power	90 W
Rated power	60 W (60-30-15 W)
Sound pressure level at	
60 W/1 W (at 1 kHz, 1 m)	110 dB/92 dB (SPL)
Effective frequency range (-10 dB)	190 Hz to 18 kHz
Opening angle	
(at 1 kHz / 4 kHz, - 6 dB)	
Horizontal	210°/132°
Vertical	50°/22°
Rated input voltage	100 V
Rated impedance	167 ohm
Ambient temperature range	-25°C to +55°C
Safety	according to EN 60065.
Connection	screw terminal block
Dimensions (H x W x D)	1200 x 80 x 90 mm
Colour	silver
Weight	6,4 kg

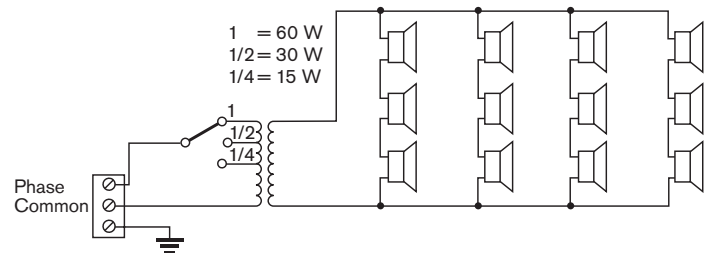
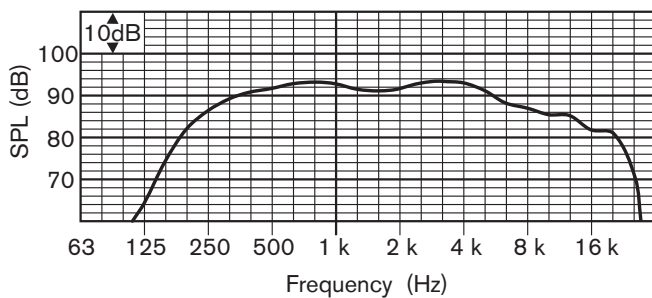

LBC 3201/00

Octave band (Hz)	250	500	1 k	2 k	4 k	8 k
SPL 1.1	88	92	92	91	91	86
SPL max.	106	110	110	109	109	104
Q-factor	2.2	3.2	6.5	12.6	23.4	53.3
Hor. Angle (deg)	360	360	210	192	132	100
Vert. Angle (deg)	107	67	50	33	22	12

Horizontal

Vertical

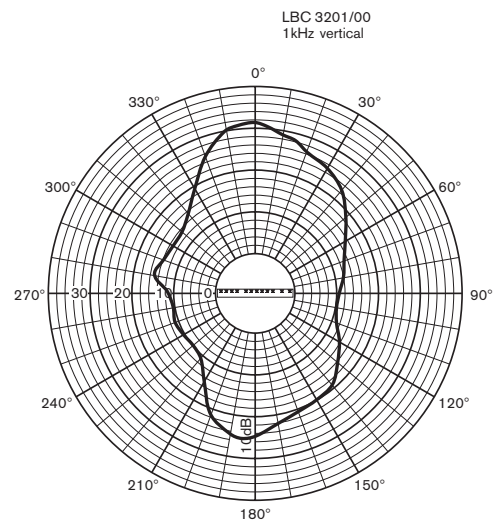
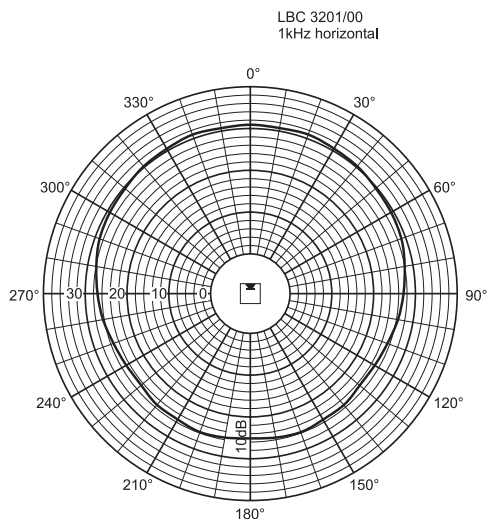
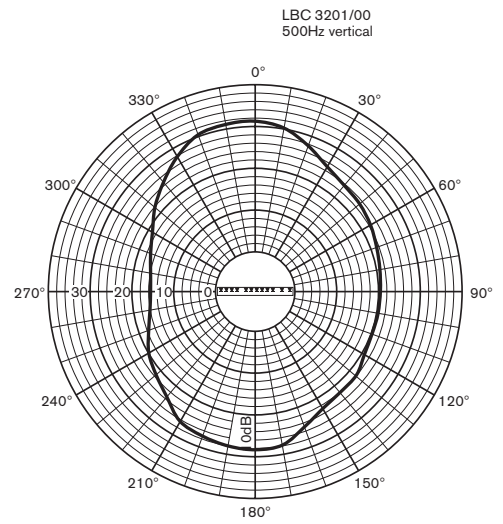
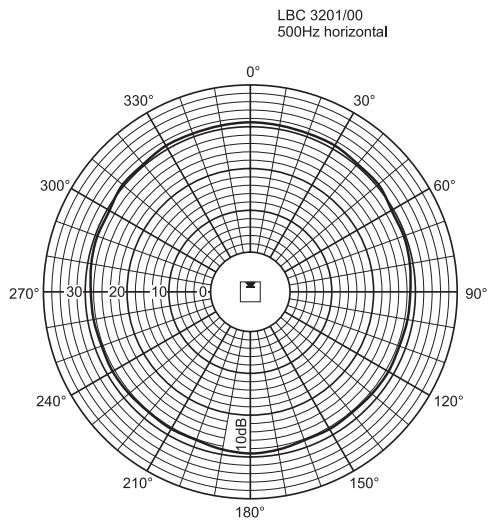
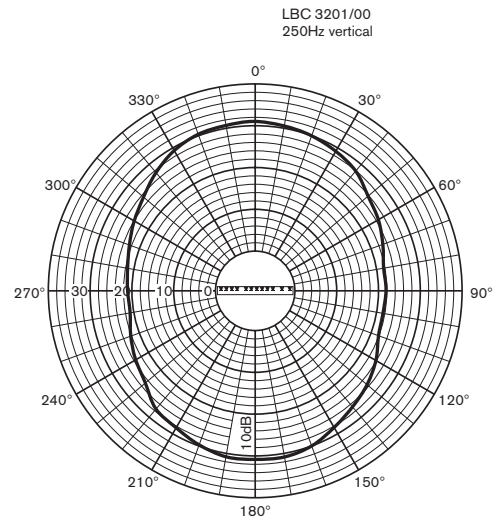
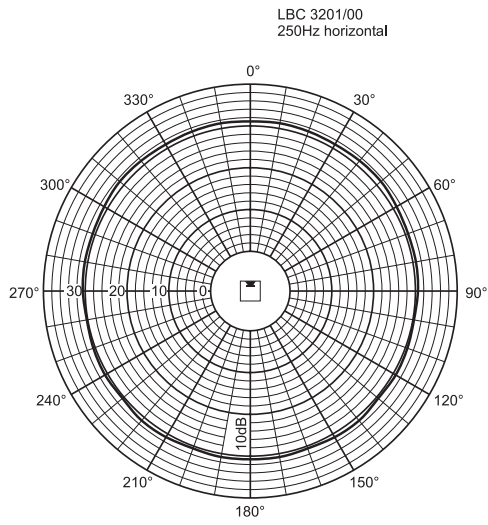

Horizontal

Vertical

LBC 3201/00
2kHz horizontal

LBC 3201/00
2kHz vertical

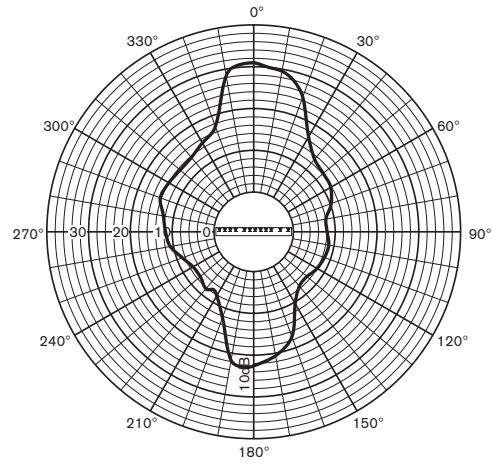
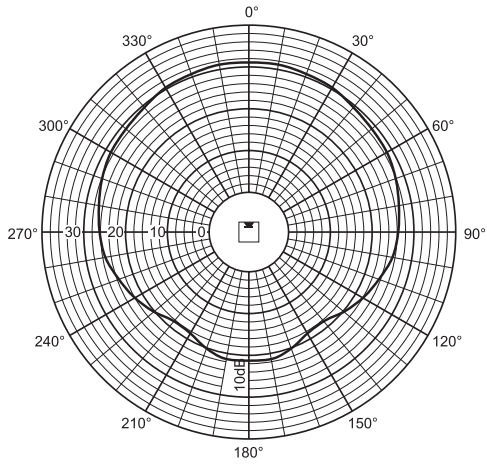

LBC 3201/00
4kHz horizontal

LBC 3201/00
4kHz vertical

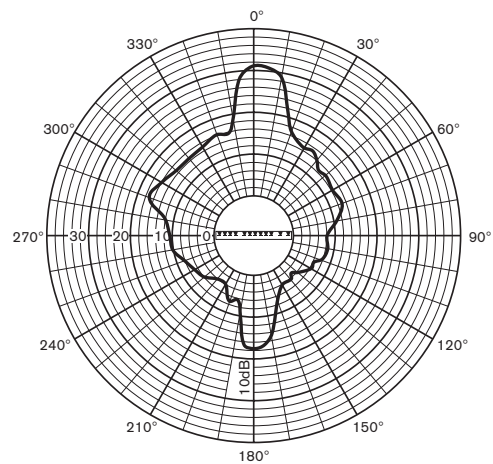
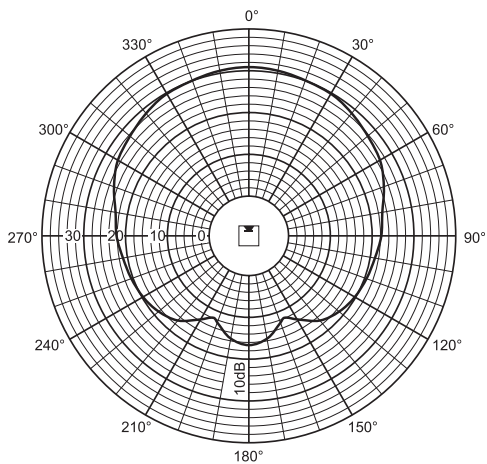

LBC 3201/00
8kHz horizontal

LBC 3201/00
8kHz vertical

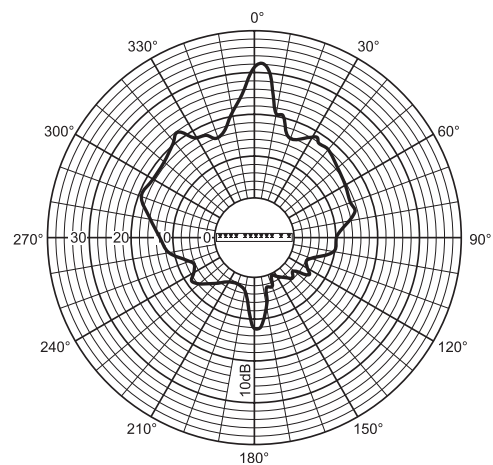
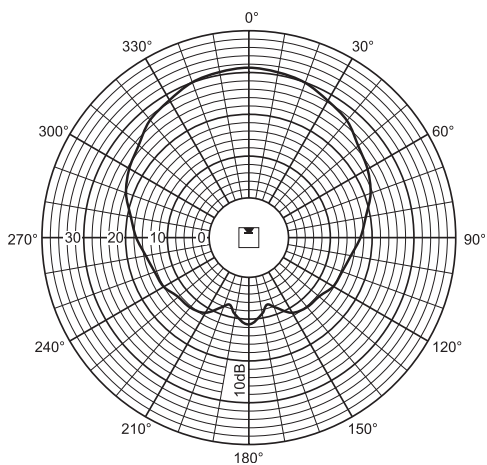

TECHNICAL PERFORMANCE DATA

LBC 3210/00

Maximum power	90 W
Rated power	60 W (60-30-15 W)
Sound pressure level	
at 60 W/1 W (at 1 kHz, 1 m)	115 dB/97 dB (SPL)
Effective frequency range (-10 dB) 190 Hz to 20 kHz	
Opening angle	
(at 1 kHz / 4 kHz, - 6 dB)	
Horizontal	170°/90°
Vertical	55°/18°
Rated input voltage	100 V
Rated impedance	167 ohm
Ambient temperature range	-25°C to +55°C
Safety	according to EN 60065.
Water/dust protection	IP 66 according to IEC 60529
Connection	screw terminal block
Dimensions (H x W x D)	1200 x 160 x 90 mm
Colour	silver
Weight	9 kg

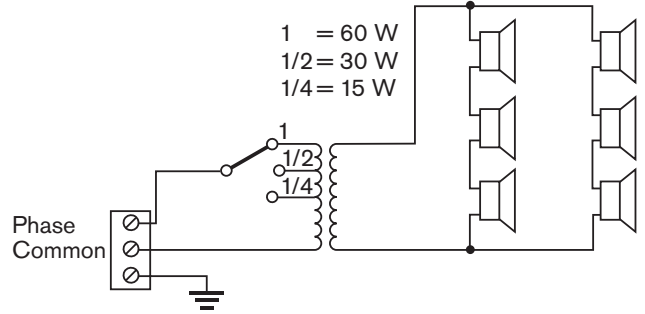
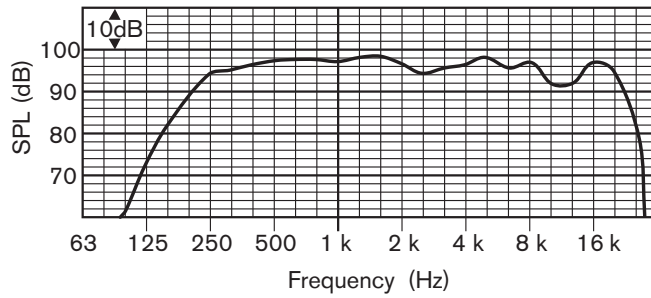

LBC 3210/00

Octave band (Hz)	250	500	1 k	2 k	4 k	8 k
SPL 1.1	94	97	97	95	96	93
SPL max.	112	115	115	113	114	111
Q-factor	2.2	2.7	6.3	10.8	22.6	32.3
Hor. Angle (deg)	360	180	170	160	90	60
Vert. Angle (deg)	100	60	55	34	18	10

Horizontal

Vertical

LBC 3210/00
250Hz horizontal

LBC 3210/00
250Hz vertical

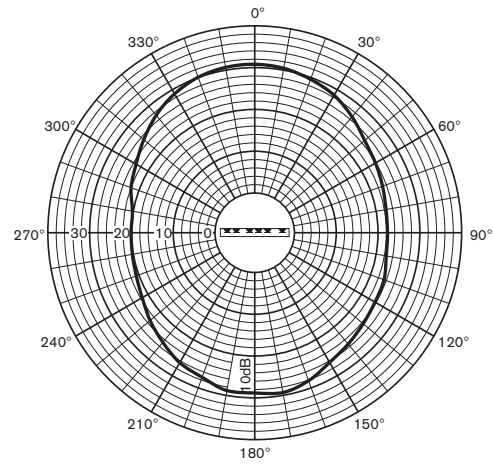
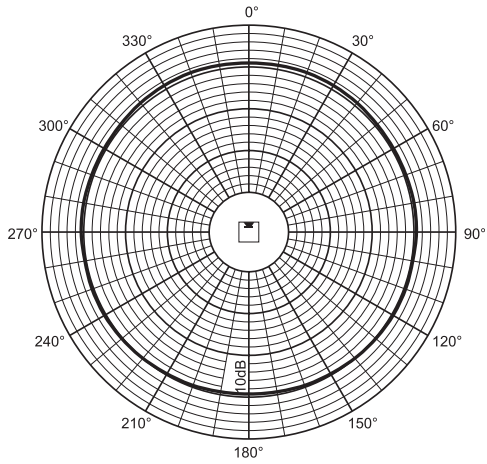

LBC 3210/00
500Hz horizontal

LBC 3210/00
500Hz vertical

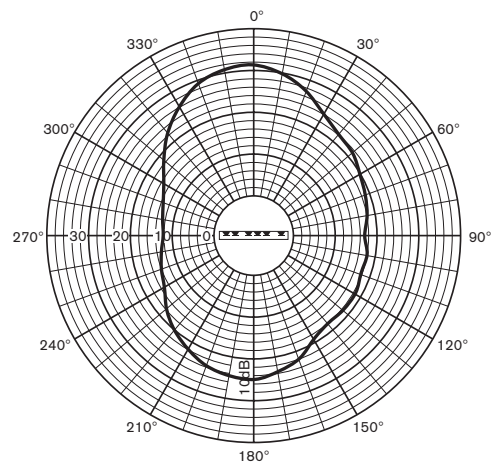
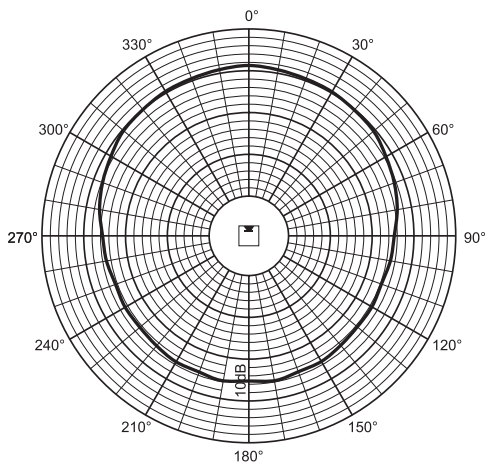

LBC 3210/00
1kHz horizontal

LBC 3210/00
1kHz vertical

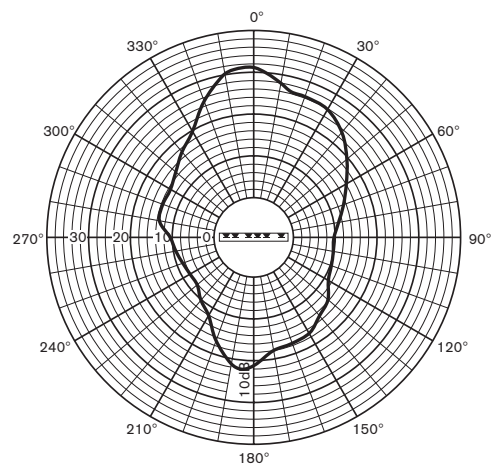
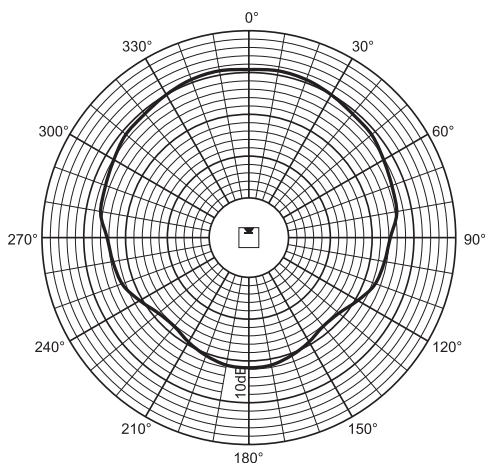

Horizontal

Vertical

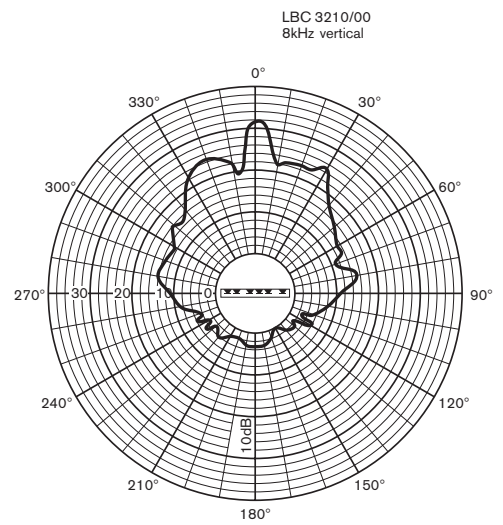
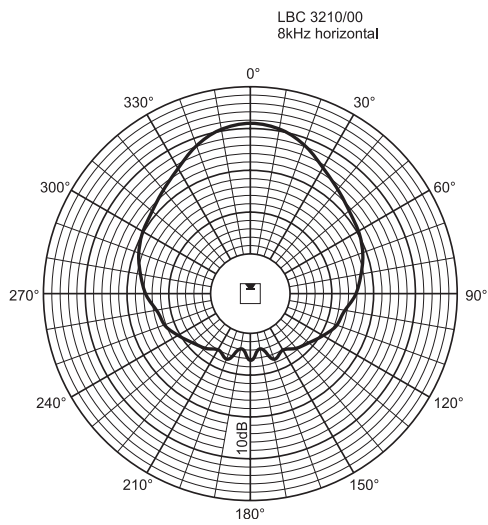
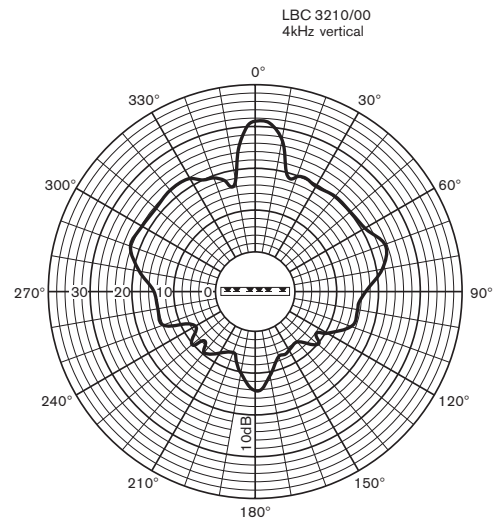
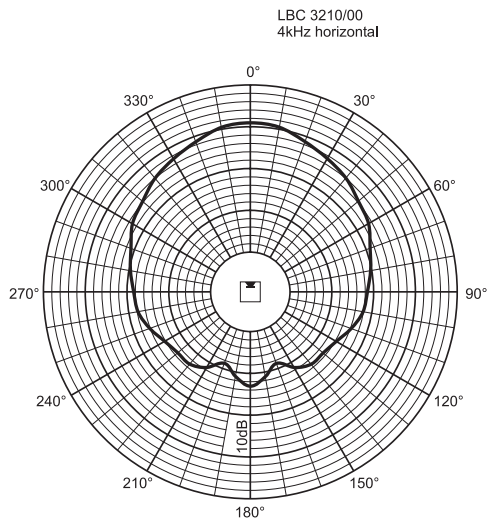
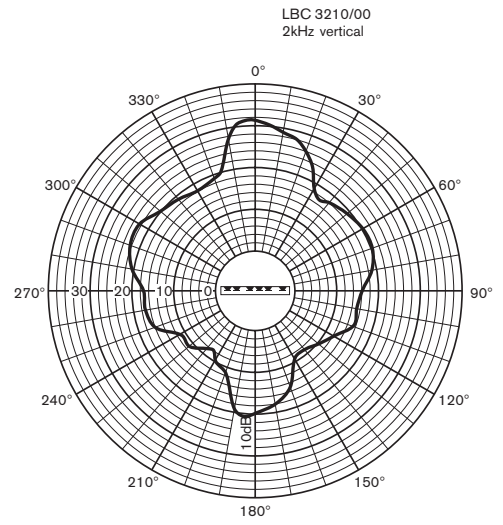
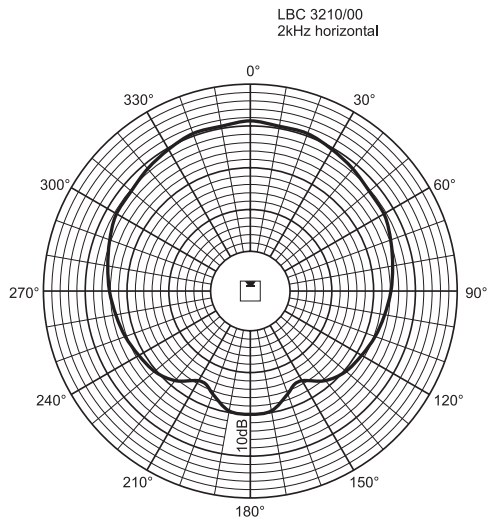

www.boschsecuritysystems.com

BOSCH

Sommaire	Page
Guide d'installation (fig. 1 - fig. 17)	28
Montage du réseau linéaire de haut-parleurs (en option) (fig. A1 - fig. A5)	30
Montage sur support complémentaire (en option) (fig. B1 - fig. B5)	30
Montage sur trépied (en option) (fig. C1 - fig. C3)	30
Zone d'écoute et hauteur de montage associée LBC 3200/00	31
Zone d'écoute et hauteur de montage associée LBC 3201/00	33
Zone d'écoute et hauteur de montage associée LBC 3210/00	36
Données techniques LBC 3200/00	39
Données techniques LBC 3201/00.....	42
Données techniques LBC 3210/00.....	45

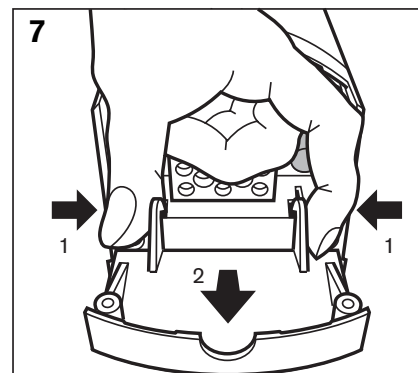
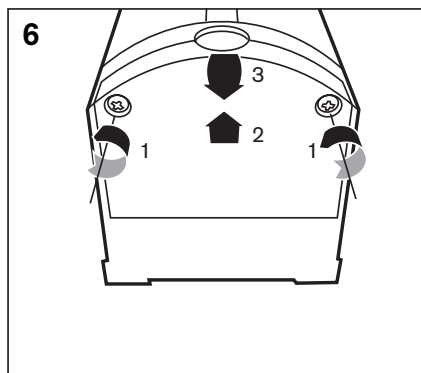
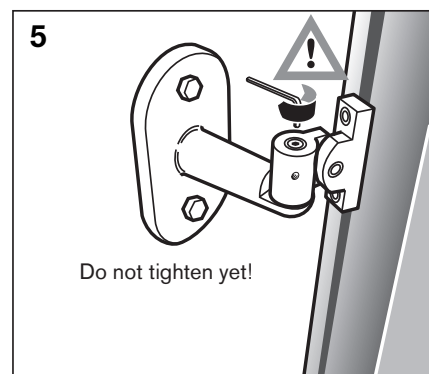
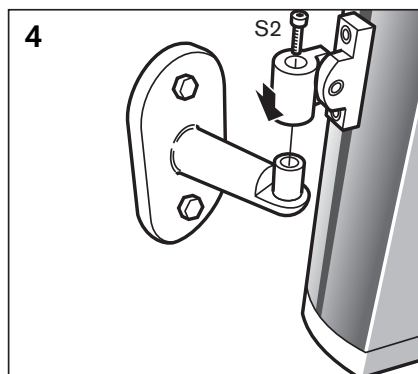
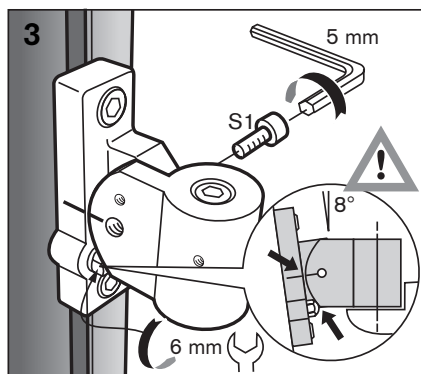
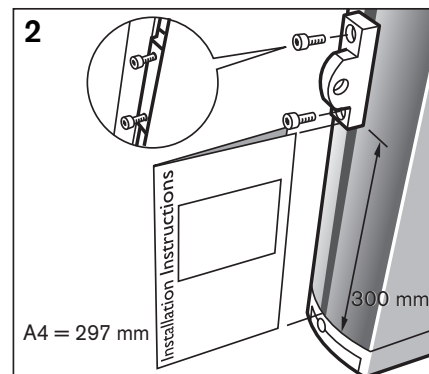
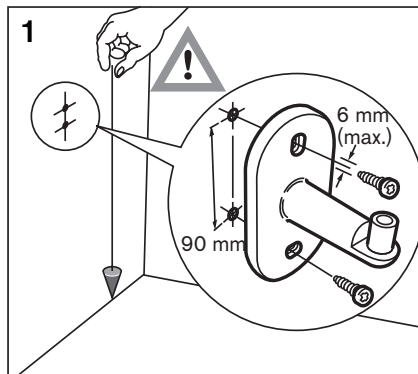
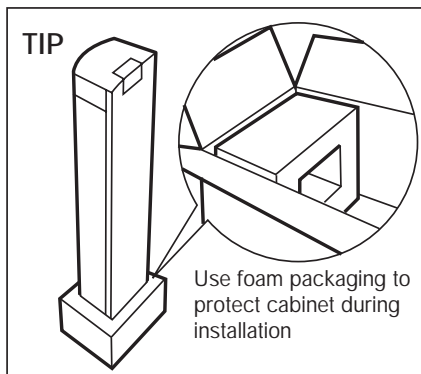
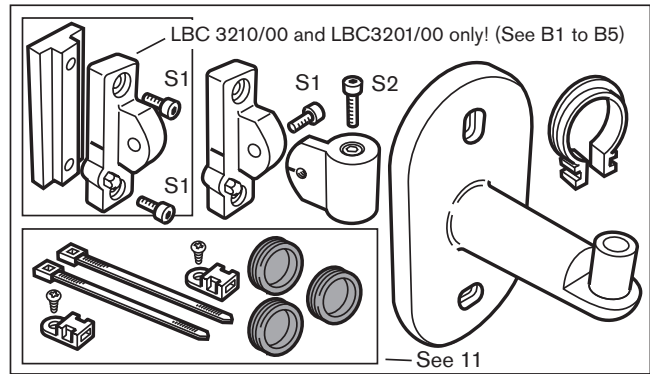
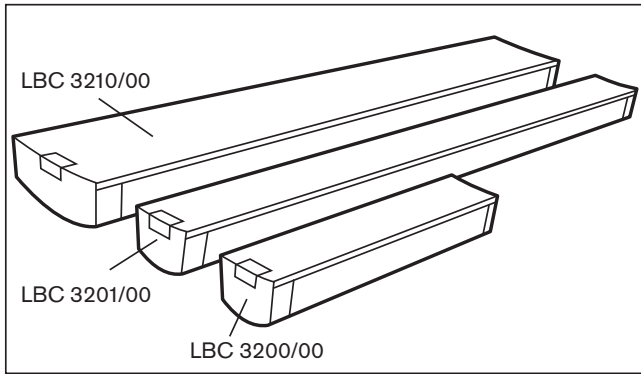

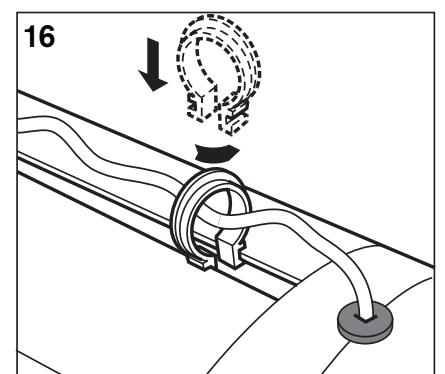
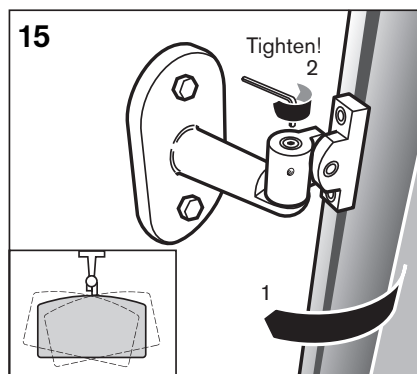
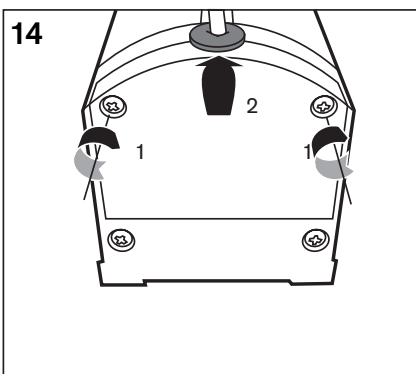
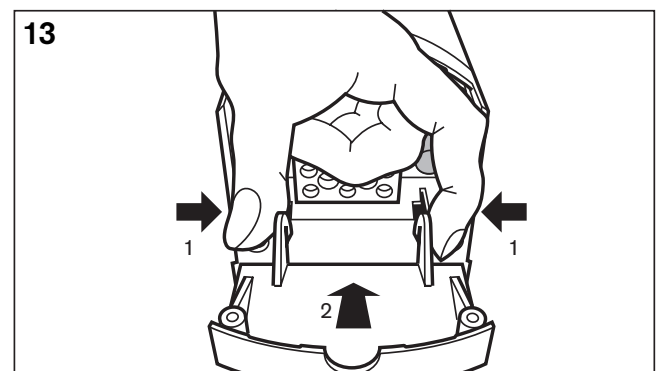
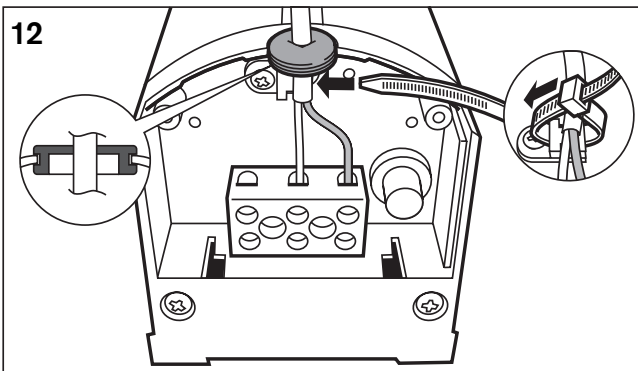
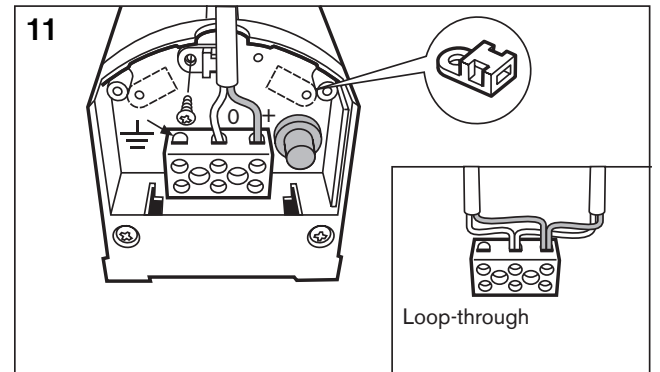
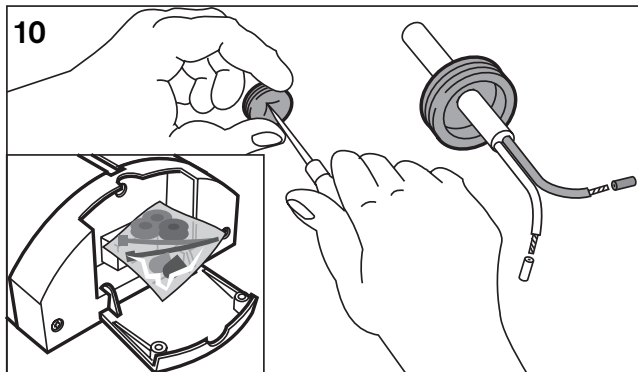
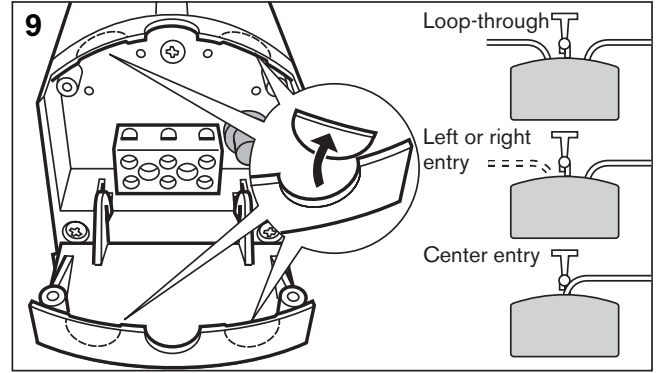
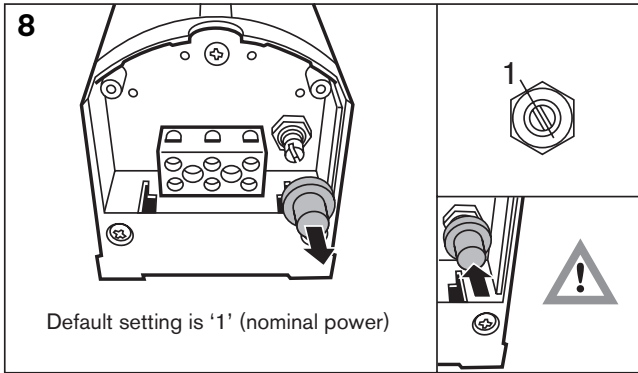

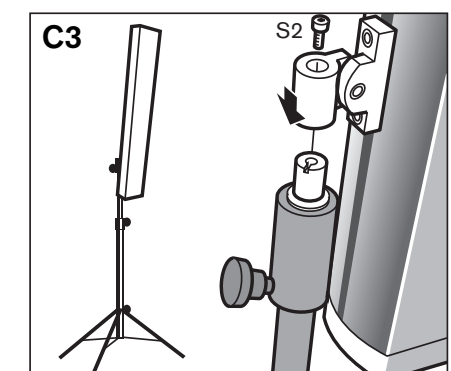
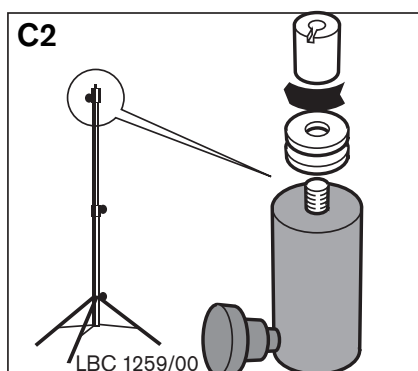
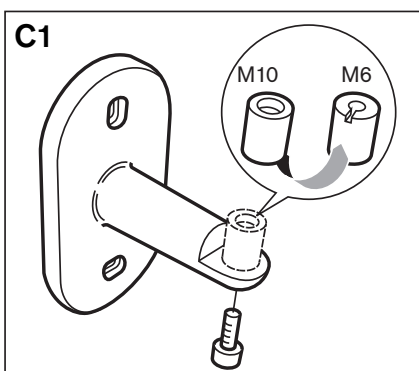
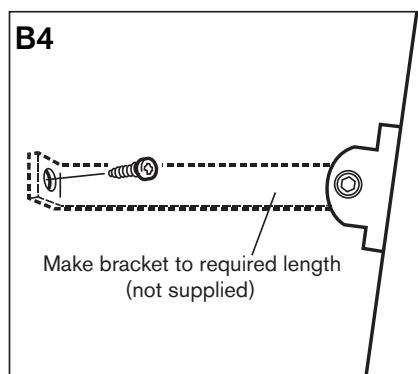
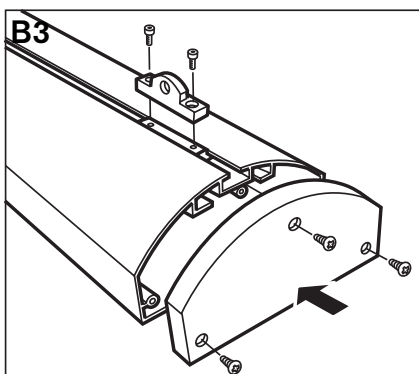
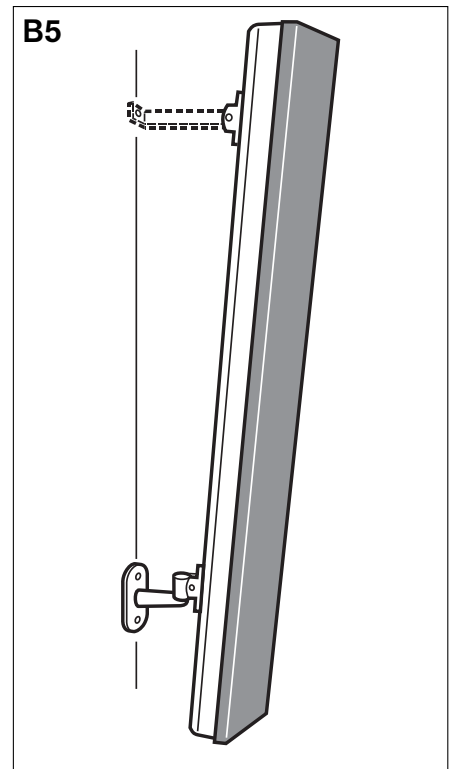
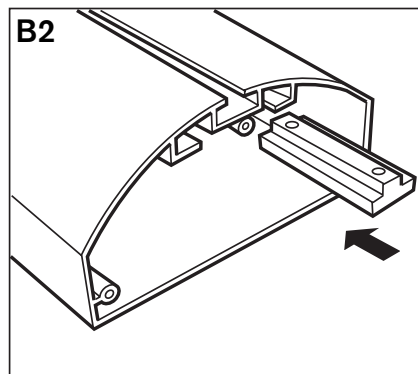
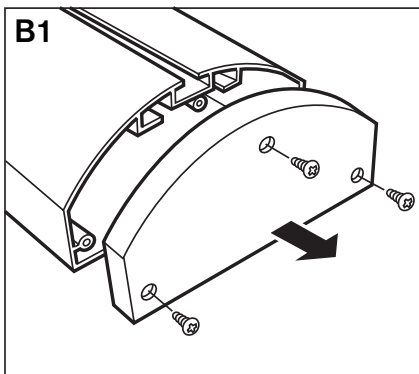
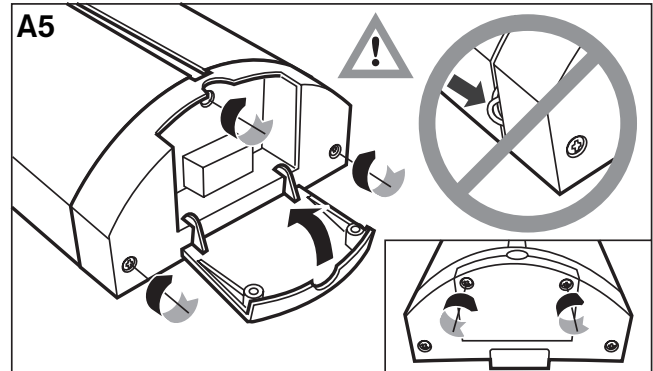
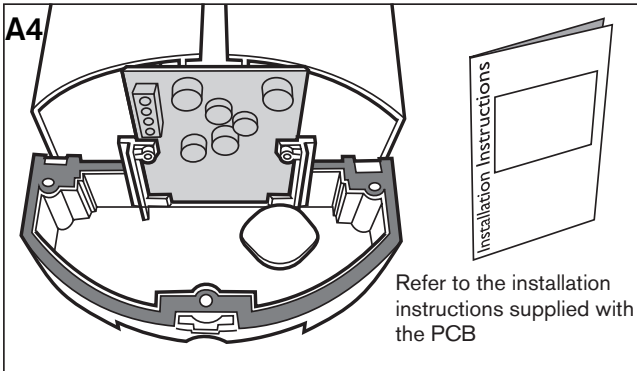
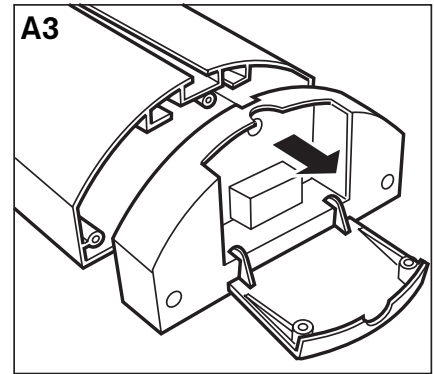
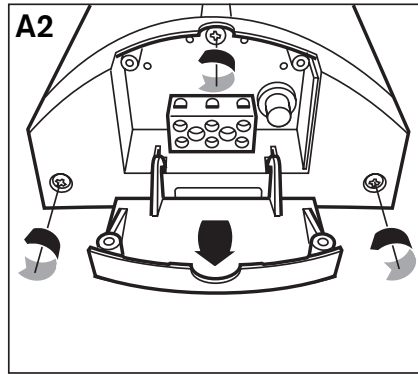
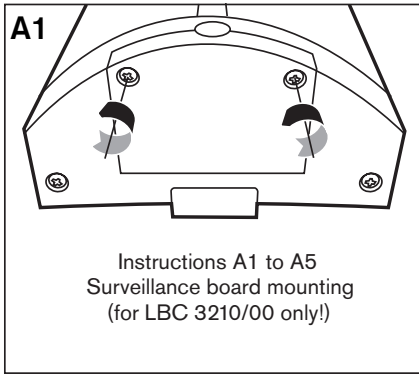

Zone d'écoute et hauteur de montage associée pour le modèle XLA 3200/00

Pour déterminer la hauteur et l'angle de montage des haut-parleurs LBC 3200 :

1. Déterminez les dimensions de la « zone d'écoute » souhaitée (plan horizontal au niveau des oreilles des auditeurs - voir la ligne en pointillés de la figure 1).
2. Déterminez l'angle de montage des haut-parleurs. Cet ensemble de haut-parleurs est conçu pour diriger le son juste au-dessus de la tête des auditeurs et il est vivement conseillé de ne pas dépasser un angle de 6 degrés. Il existe deux techniques de montage, chacune possédant ses avantages et ses inconvénients.
 - **Technique n°1 : zone d'écoute maximale**
Si vous souhaitez une large zone d'écoute, il est recommandé de choisir un angle d'environ 3 degrés (voir figure 1). Notez que lorsque vous vous éloignez des haut-parleurs, le niveau de pression acoustique baisse, et ce en fonction de la réverbération de la pièce. Pour entendre clairement les sons aigus, l'auditeur doit voir l'ensemble des haut-parleurs.
 - **Technique n°2 : variation minimale du niveau de pression acoustique**
Pour limiter au maximum la variation du niveau de pression acoustique, il est recommandé de choisir un angle de 5 degrés. Notez que cette technique réduit la taille de la zone d'écoute totale par rapport à la première technique et que l'espace le plus proche des haut-parleurs (« A » dans la figure 2) ne fait pas partie de la zone d'écoute. Le schéma 1 illustre le rapport entre la zone « A » et la hauteur de montage des haut-parleurs lorsque vous installez ces derniers à un angle de 5 degrés.
3. Après avoir choisi la technique la plus adéquate (angle de montage), vous pouvez déterminer la hauteur de montage du haut-parleur en orientant l'axe à 0 degré de l'ensemble de haut-parleurs vers l'emplacement souhaité, situé juste au-dessus de l'oreille de l'auditeur le plus éloigné. Vous pouvez effectuer ce réglage en installant le haut-parleur plus ou moins haut sur le mur.

Vous savez désormais monter les haut-parleurs pour obtenir des performances acoustiques optimales.

Questions/réponses relatives à l'installation :

- **Puis-je installer l'ensemble de haut-parleurs LBC 3200 de la même manière que les modèles LBC 3210 ou LBC 3201 ?**
Cet ensemble de haut-parleurs est conçu pour être utilisé en intérieur, dans un espace restreint ou moyen. Pour obtenir des performances acoustiques optimales, dirigez le son juste au-dessus de la tête des auditeurs. Si vous montez ces haut-parleurs de la même manière que

les modèles LBC 3210 ou LBC 3201, vous obtiendrez une zone d'écoute très restreinte. C'est également la raison pour laquelle vous ne devez pas utiliser un angle de plus de 6 degrés.

- **Si je ne peux pas voir les haut-parleurs, cela signifie-t-il que je ne peux pas entendre les sons aigus ?**
Vous pouvez comparer les sons aigus à la lumière. Lorsqu'un obstacle vous sépare d'une source de lumière, vous ne percevez pas pleinement son intensité. On parle d'ombre. Le phénomène est identique pour les sons aigus. Si de nombreuses personnes se trouvent entre le haut-parleur et vous, vous êtes dans une zone d'ombre acoustique. Les sons aigus sont donc diminués.

Informations générales :

- En raison des nombreux angles d'installation possibles, il est difficile de donner une forme définie au son émis par les haut-parleurs.
- Si l'angle d'installation des haut-parleurs est faible, vous pouvez obtenir une (très) large zone d'écoute. À une certaine distance des haut-parleurs, l'intelligibilité de la parole peut être affaiblie en fonction de l'importance de la réverbération de la pièce et de l'ombre acoustique (personnes ou objets placés devant l'auditeur et bloquant la source sonore directe). Dans ce cas, il est préférable d'utiliser plusieurs ensembles de haut-parleurs pour diviser la zone d'écoute.
- Lorsque vous franchissez les limites de la zone d'écoute (distance supérieure à la distance maximale d'éloignement par rapport aux haut-parleurs), seul le niveau de pression acoustique diminue. Vous ne percevez presque aucune variation de la hauteur des sons. La diminution du niveau de pression acoustique dépend étroitement de la réverbération de la pièce.
- Si vous êtes trop près des haut-parleurs (distance inférieure à la distance minimale d'éloignement par rapport aux haut-parleurs) et que vous utilisez un angle de 5 degrés, les sons aigus diminuent très rapidement.
- Les haut-parleurs étant conçus pour diriger le son juste au-dessus de la tête des auditeurs, il est conseillé de ne pas les installer trop haut par rapport à la zone d'écoute.
- Pour déterminer les limites exactes de votre zone d'écoute, il vous suffit d'effectuer un test pratique là où vos haut-parleurs sont installés. Ce test doit être accompli par une oreille exercée. Pour ce faire, émettez un bruit rose par l'intermédiaire de vos haut-parleurs. Il est conseillé de réduire les sons graves lors de ce test car ceux-ci peuvent dégrader à l'intelligibilité de la parole. Parcourez la zone d'écoute et suivez les sons aigus. Lorsque les sons aigus diminuent rapidement, vous êtes à la limite de la zone d'écoute.

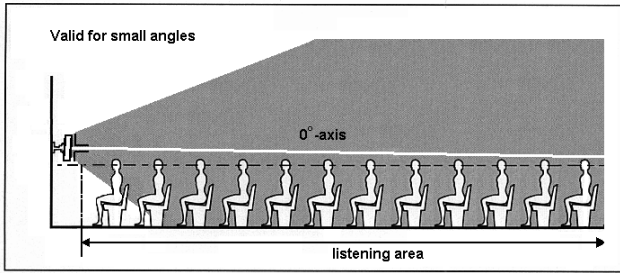

Figure 1 Vue latérale des émissions sonores des haut-parleurs montage mural avec angle faible

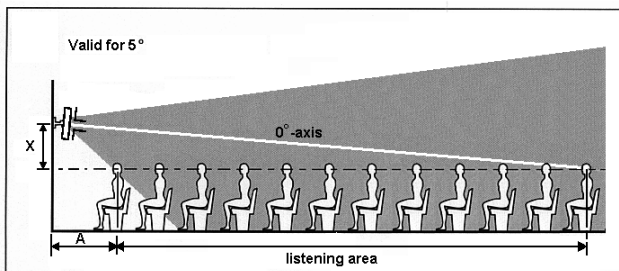

Figure 2 Vue latérale des émissions sonores des haut-parleurs montage mural avec angle de 5 degrés



Schéma 1 Rapport entre la distance de la zone d'écoute et les haut-parleurs

Zone d'écoute et hauteur de montage associée pour la XLA 3201/00

Comment utiliser ces méthodes de montage :

1. Déterminez les dimensions de la « zone d'écoute » souhaitée (plan horizontal au niveau des oreilles des auditeurs - voir la ligne en pointillés de la figure 1).
2. Mesurez la distance maximale entre les haut-parleurs et l'auditeur le plus éloigné de la zone d'écoute (correspondant à « B » dans les figures 1, 2 et 3).
3. Reportez-vous au schéma 1 et tracez une ligne verticale à partir de la distance maximale indiquée sur l'axe horizontal. À l'intersection de cette ligne avec la diagonale B, reportez-vous horizontalement sur l'axe vertical. La valeur X (hauteur du support de montage des haut-parleurs au-dessus du plan d'écoute représentée par « X » dans la figure 1) se trouve sur cet axe. Les intersections des lignes horizontales avec les autres diagonales indiquent les dimensions de la zone d'écoute. Ces chiffres correspondent aux figures 2 et 3 (voir également l'exemple ci-dessous).
4. La figure 2 indique la forme de l'octave d'1 kHz émise par les haut-parleurs et la figure 3 montre l'émission de la forme de l'octave de 4 kHz. La zone d'écoute offrant des performances acoustiques optimales se situe entre ces formes. Vérifiez que la forme de 4 kHz, qui tire ses dimensions du schéma 1, couvre de manière appropriée la zone d'écoute souhaitée.
5. Si la zone d'écoute souhaitée est couverte par la forme de 4 kHz, la valeur X de l'axe vertical indique la hauteur à laquelle les haut-parleurs doivent être installés au-dessus du plan d'écoute. Notez que les haut-parleurs doivent être montés à un angle de 8 degrés à la hauteur choisie.

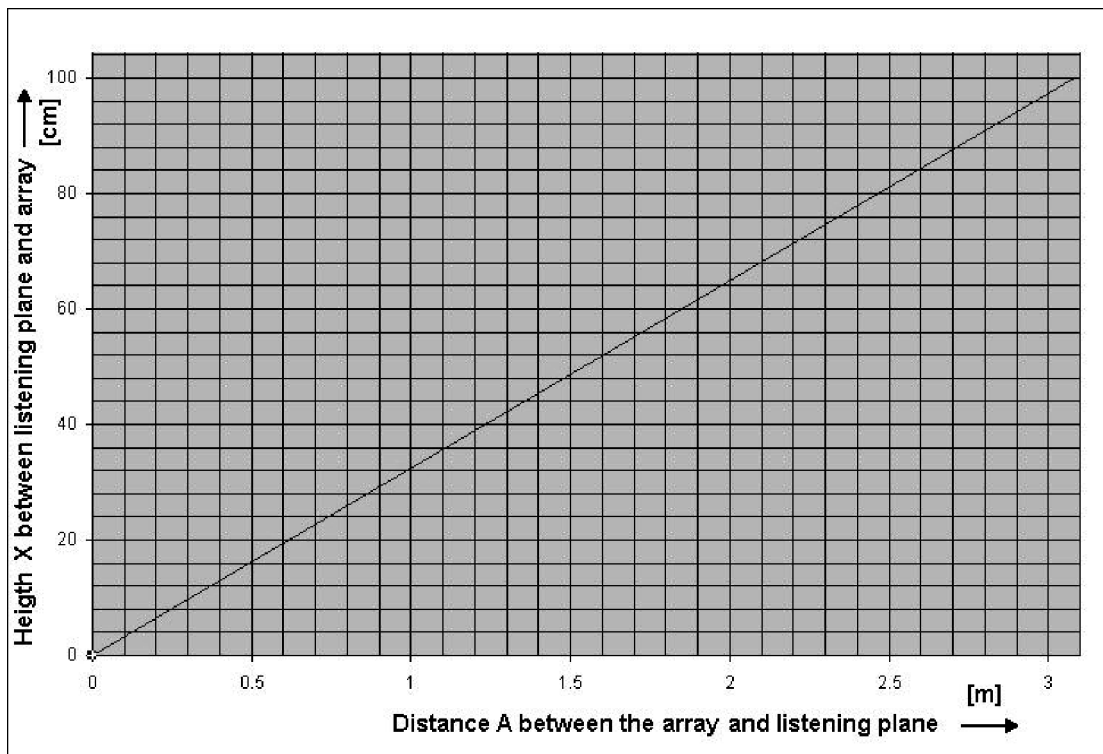
Vous savez désormais monter les haut-parleurs pour obtenir des performances acoustiques optimales.

Exemple :

La distance maximale entre les haut-parleurs et l'auditeur le plus éloigné est de 15 m. Tracez une ligne verticale correspondant à 15 m sur l'axe horizontal du schéma 1 qui coupe la diagonale B, puis tracez la ligne horizontale passant par ce point vers l'axe vertical. L'intersection de ces lignes avec les autres diagonales indique les dimensions des plans d'écoute. Dans cet exemple :

Ligne F (longueur latérale du plan d'écoute de 4 kHz) = 11,1 m

Ligne C (longueur du plan d'écoute) = 11 m

Ligne E (plan d'écoute de 4 kHz à mi-largeur) = 9,3 m

Ligne A (distance minimale jusqu'au plan d'écoute) = 3,9 m

Sur l'axe vertical, la valeur X (hauteur entre le plan d'écoute et le support de montage des haut-parleurs) correspond à 1,8 m.

Questions/réponses relatives à l'installation :

- **La zone d'écoute souhaitée est trop large et ne s'intègre pas dans la forme de 4 kHz.**
Modifiez la hauteur de montage ou utilisez d'autres ensembles de haut-parleurs pour élargir la zone d'écoute.
- **Pourquoi utiliser un angle de 8 degrés pour les haut-parleurs ?**
Les formes émises, indiquées dans les figures 2 et 3 et correspondant aux dimensions du schéma 1, sont valides uniquement lorsque l'angle de montage des haut-parleurs est de 8 degrés. Seul ce montage offre un niveau de pression acoustique et une réponse en fréquence (directivité constante) constants dans la zone d'écoute.
- **Puis-je utiliser les haut-parleurs avec un autre angle ?**
Vous pouvez également utiliser les haut-parleurs avec un autre angle mais leurs performances acoustiques ne seront pas optimales. Par exemple, le niveau de pression acoustique variera davantage dans la zone d'écoute. Les valeurs du schéma 1 ne sont pas valables pour les autres angles. Il est recommandé de ne jamais utiliser un angle supérieur à 8 degrés.
- **Les haut-parleurs ne peuvent pas être installés à la hauteur souhaitée.**
Si la hauteur souhaitée ne peut être atteinte, à cause du plafond par exemple, utilisez un angle inférieur à 8 degrés. Orientez l'axe à 0 degré des haut-parleurs vers la position maximale souhaitée (voir la figure 4). Notez que le tableau du schéma 1 et les formes des figures 2 et 3 ne sont pas valables dans ce cas. Vérifiez dans la zone d'écoute que l'intelligibilité de la parole est acceptable.

Informations générales :

- Les formes sont définies dans un environnement sourd. Dans ces formes en environnement sourd, la variation de la pression acoustique s'élève à 6 dB maximum et la variation de réponse en fréquence est beaucoup moins perceptible. Dans des zones où la réverbération est normale ou élevée, le niveau de pression acoustique varie moins et les formes sont plus larges. La réponse en fréquence perçue dans cette forme est alors presque constante.
- Lorsque vous franchissez les limites de la zone d'écoute (au-delà de la distance maximale d'éloignement par rapport aux haut-parleurs), seule la pression acoustique diminue. Vous ne percevez presque aucune variation de la hauteur des sons. La diminution du niveau de pression acoustique dépend étroitement de la réverbération de la pièce.
- Si vous êtes trop près des haut-parleurs (distance inférieure à la distance minimale d'éloignement par rapport aux haut-parleurs), les sons aigus diminuent très rapidement.

- À une certaine distance des haut-parleurs, l'intelligibilité de la parole peut être affaiblie en fonction de la quantité de réverbération de la pièce et de l'ombre acoustique (personnes ou objets placés devant l'auditeur et bloquant la source sonore directe). Dans ce cas, il est préférable d'utiliser plusieurs ensembles de haut-parleurs pour diviser la zone d'écoute.
- Les lignes latérales des formes des figures 2 et 3 correspondent aux valeurs de -6 dB relatives au niveau de pression acoustique de l'axe à 0 degré.
- Pour obtenir la meilleure intelligibilité de parole possible, définissez une zone d'écoute où la forme de l'octave de 4 kHz couvre toute la zone.
- Pour déterminer les limites exactes de votre zone d'écoute, il vous suffit d'effectuer un test pratique là où vos haut-parleurs sont installés. Ce test doit être accompli par une oreille exercée. Pour ce faire, émettez un bruit rose par l'intermédiaire de vos haut-parleurs. Il est conseillé de réduire les sons graves lors de ce test car ceux-ci ne contribuent en rien à l'intelligibilité de la parole. Parcourez la zone d'écoute et suivez les sons aigus. Lorsque les sons aigus diminuent rapidement, vous êtes à la limite de la zone d'écoute.



Schéma 1: Rapport entre la zone d'écoute et la hauteur de montage des haut-parleurs

Légende des diagonales

Ligne B : distance maximale entre les haut-parleurs et l'auditeur le plus éloigné

Ligne D : plan d'écoute d'1 kHz à mi-largeur

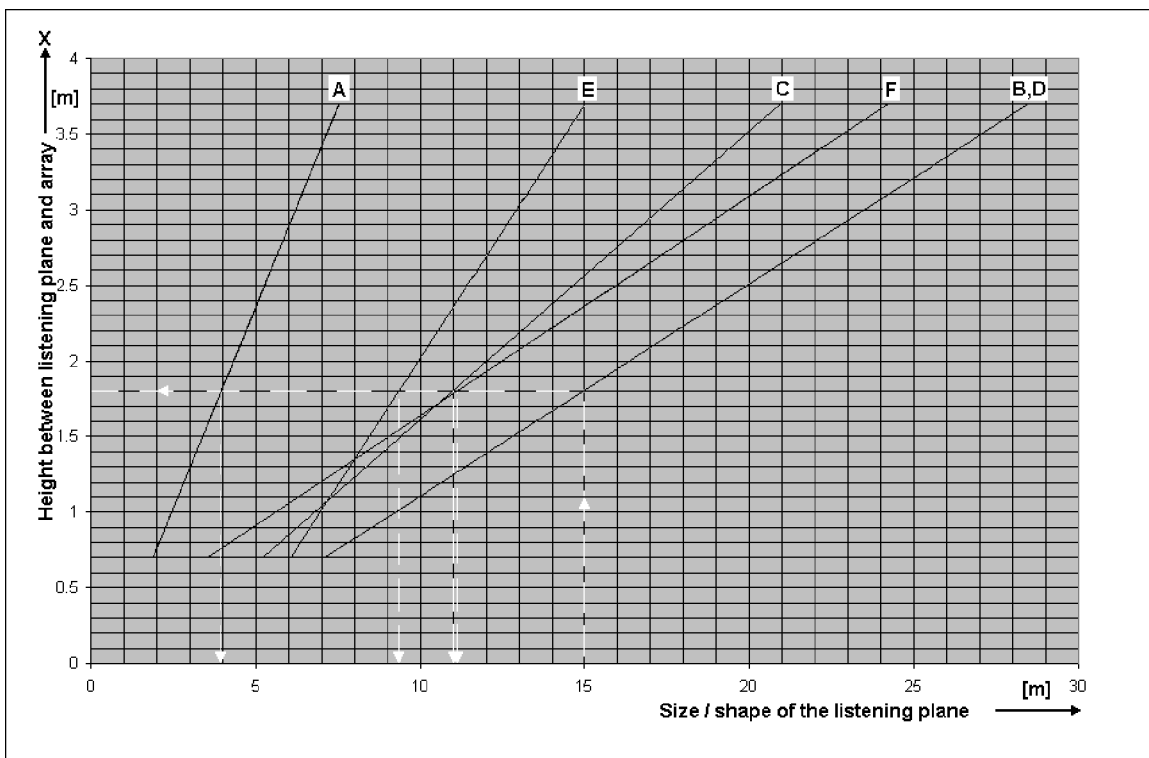
Ligne F : longueur latérale du plan d'écoute de 4 kHz

Ligne C : longueur du plan d'écoute

Ligne E : plan d'écoute de 4 kHz à mi-largeur

Ligne A : distance minimale par rapport au plan d'écoute

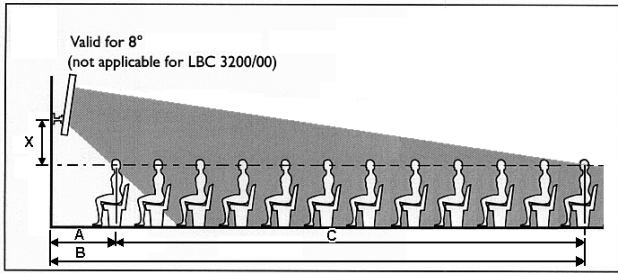

Figure 1: Vue latérale de l'émission sonore des haut-parleurs et du plan d'écoute

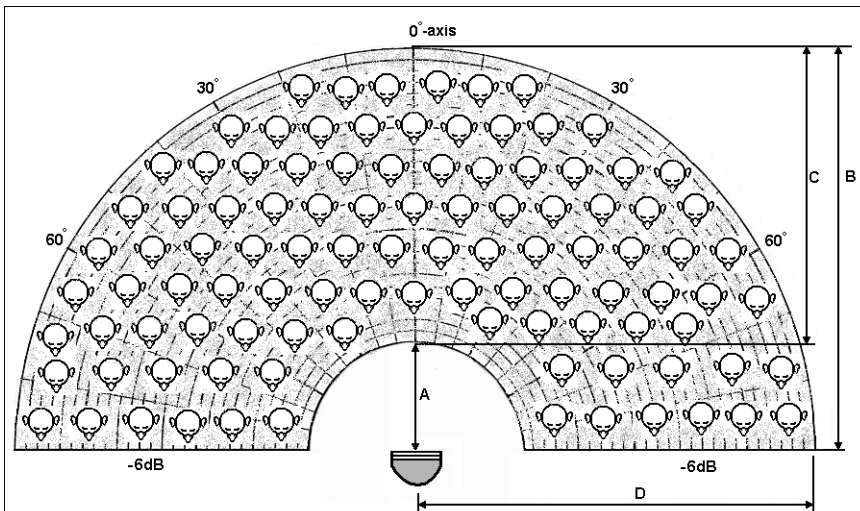

Figure 2: Forme de l'octave d'1 kHz des haut-parleurs

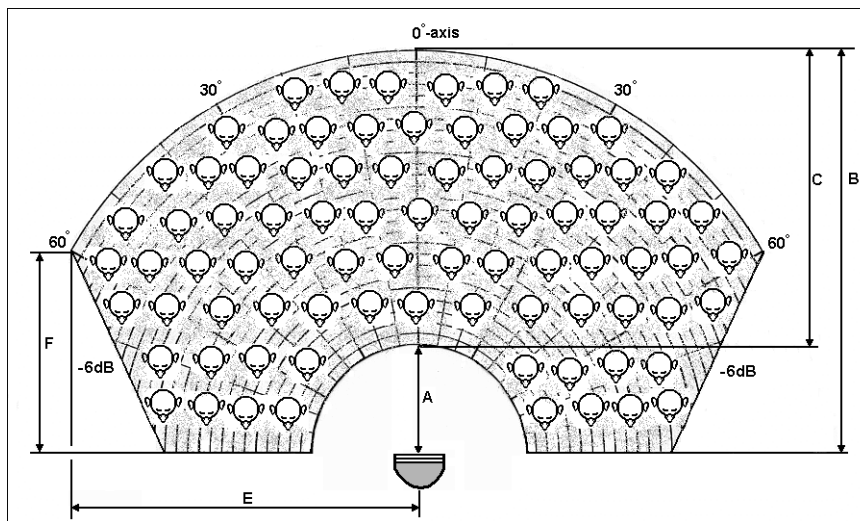

Figure 3: Forme de l'octave de 4 kHz des haut-parleurs

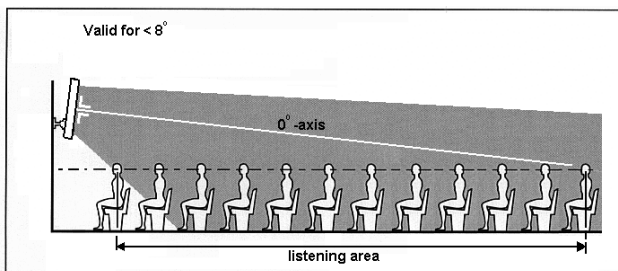

Figure 4: Orientation de l'axe à 0 degré des haut-parleurs vers la position maximale

Zone d'écoute et hauteur de montage associée pour le XLA 3210/00

Comment utiliser ces méthodes de montage

1. Déterminez les dimensions de la « zone d'écoute » souhaitée (plan horizontal au niveau des oreilles des auditeurs - voir la ligne en pointillés de la figure 1).
2. Mesurez la distance maximale entre les haut-parleurs et l'auditeur le plus éloigné de la zone d'écoute (correspondant à « B » dans les figures 1, 2 et 3).
3. Reportez-vous au schéma 1 et tracez une ligne verticale à partir de la distance maximale indiquée sur l'axe horizontal. À l'intersection de cette ligne avec la diagonale B, reportez-vous horizontalement sur l'axe vertical. La valeur X (hauteur du support de montage des haut-parleurs au-dessus du plan d'écoute représentée par « X » dans la figure 1) se trouve sur cet axe. Les intersections des lignes horizontales avec les autres diagonales indiquent les dimensions de la zone d'écoute. Ces chiffres correspondent aux figures 2 et 3 (voir également l'exemple ci-dessous).
4. La figure 2 indique la forme de l'octave d'1 kHz émise par les haut-parleurs et la figure 3 montre l'émission de la forme de l'octave de 4 kHz. La zone d'écoute offrant des performances acoustiques optimales se situe entre ces formes. Vérifiez que la forme de 4 kHz, qui tire ses dimensions du schéma 1, couvre de manière appropriée la zone d'écoute souhaitée.
5. Si la zone d'écoute souhaitée est couverte par la forme de 4 kHz, la valeur X de l'axe vertical indique la hauteur à laquelle les haut-parleurs doivent être installés au-dessus du plan d'écoute. Notez que les haut-parleurs doivent être montés à un angle de 8 degrés à la hauteur choisie.

Vous savez désormais monter les haut-parleurs pour obtenir des performances acoustiques optimales.

Exemple de schéma :

La distance maximale entre les haut-parleurs et l'auditeur le plus éloigné est de 15 m. Tracez une ligne verticale correspondant à 15 m sur l'axe horizontal du schéma 1 qui coupe la diagonale B, puis tracez la ligne horizontale passant par ce point vers l'axe vertical. L'intersection de ces lignes avec les autres diagonales indique les dimensions des plans d'écoute. Dans cet exemple :

Ligne F (longueur latérale du plan d'écoute de 4 kHz) = 12,2 m

Ligne C (longueur du plan d'écoute) = 11 m

Ligne E (plan d'écoute de 4 kHz à mi-largeur) = 8,6 m

Ligne A (distance minimale jusqu'au plan d'écoute) = 3,9 m

Sur l'axe vertical, la valeur X (hauteur entre le plan d'écoute et le support de montage des haut-parleurs) correspond à 1,8 m.

Questions/réponses relatives à l'installation :

- **La zone d'écoute souhaitée est trop large et ne s'intègre pas dans la forme de 4 kHz.**
Modifiez la hauteur de montage ou utilisez d'autres ensembles de haut-parleurs pour élargir la zone d'écoute.
- **Pourquoi utiliser un angle de 8 degrés pour les haut-parleurs ?**
Les formes émises, indiquées dans les figures 2 et 3 et correspondant aux dimensions du schéma 1, sont valides uniquement lorsque l'angle de montage des haut-parleurs est de 8 degrés. Seul ce montage offre un niveau de pression acoustique et une réponse en fréquence (directivité constante) constants dans la zone d'écoute.
- **Puis-je utiliser les haut-parleurs avec un autre angle ?**
Vous pouvez également utiliser les haut-parleurs avec un autre angle mais leurs performances acoustiques ne seront pas optimales. Par exemple, le niveau de pression acoustique variera davantage dans la zone d'écoute. Les valeurs du schéma 1 ne sont pas valables pour les autres angles. Il est recommandé de ne jamais utiliser un angle supérieur à 8 degrés.
- **Les haut-parleurs ne peuvent pas être installés à la hauteur souhaitée.**
Si la hauteur souhaitée ne peut être atteinte, à cause du plafond par exemple, utilisez un angle inférieur à 8 degrés. Orientez l'axe à 0 degré des haut-parleurs vers la position maximale souhaitée (voir la figure 4). Notez que le tableau du schéma 1 et les formes des figures 2 et 3 ne sont pas valables dans ce cas. Vérifiez dans la zone d'écoute que l'intelligibilité de la parole est acceptable car les messages doivent être audibles.

Informations générales :

- Les formes sont définies dans un environnement sourd. Dans ces formes en environnement sourd, la variation de la pression acoustique s'élève à 6 dB maximum et la variation de réponse en fréquence est beaucoup moins perceptible. Dans des zones où la réverbération est normale ou élevée, le niveau de pression acoustique varie moins et les formes sont plus larges. La réponse en fréquence perçue dans cette forme est alors presque constante.
- Lorsque vous franchissez les limites de la zone d'écoute (au-delà de la distance maximale d'éloignement par rapport aux haut-parleurs), seule la pression acoustique diminue. Vous ne percevez presque aucune variation de la hauteur des sons. La diminution du niveau de pression acoustique dépend étroitement de la réverbération de la pièce.
- Si vous êtes trop près des haut-parleurs (distance inférieure à la distance minimale d'éloignement par rapport aux haut-parleurs), les sons aigus diminuent très rapidement.
- À une certaine distance des haut-parleurs, l'intelligibilité de la parole peut être affaiblie en

fonction de la quantité de réverbération de la pièce et de l'ombre acoustique (personnes ou objets placés devant l'auditeur et bloquant la source sonore directe). Dans ce cas, il est préférable d'utiliser plusieurs ensembles de haut-parleurs pour diviser la zone d'écoute.

- Les lignes latérales des formes des figures 2 et 3 correspondent aux valeurs de -6 dB relatives au niveau de pression acoustique de l'axe à 0 degré.
- Pour obtenir la meilleure intelligibilité de parole possible, définissez une zone d'écoute où la forme de l'octave de 4 kHz couvre toute la zone. Pour déterminer les limites exactes de votre zone d'écoute, il vous suffit d'effectuer un test pratique là où vos haut-parleurs sont installés. Ce test doit être accompli par une oreille exercée. Pour ce faire, émettez un bruit rose par l'intermédiaire de vos haut-parleurs. Il est conseillé de réduire les sons graves lors de ce test car ceux-ci ne contribuent en rien à l'intelligibilité de la parole. Parcourez la zone d'écoute et suivez les sons aigus. Lorsque les sons aigus diminuent rapidement, vous êtes à la limite de la zone d'écoute.



Schéma 1: Rapport entre la zone d'écoute et la hauteur de montage des haut-parleurs

Légende des lignes

- Ligne B : distance maximale entre les haut-parleurs et l'auditeur le plus éloigné
- Ligne D : plan d'écoute d'1 kHz à mi-largeur
- Ligne F : longueur latérale du plan d'écoute de 4 kHz
- Ligne C : longueur du plan d'écoute
- Ligne E : plan d'écoute de 4 kHz à mi-largeur
- Ligne A : distance minimale par rapport au plan d'écoute

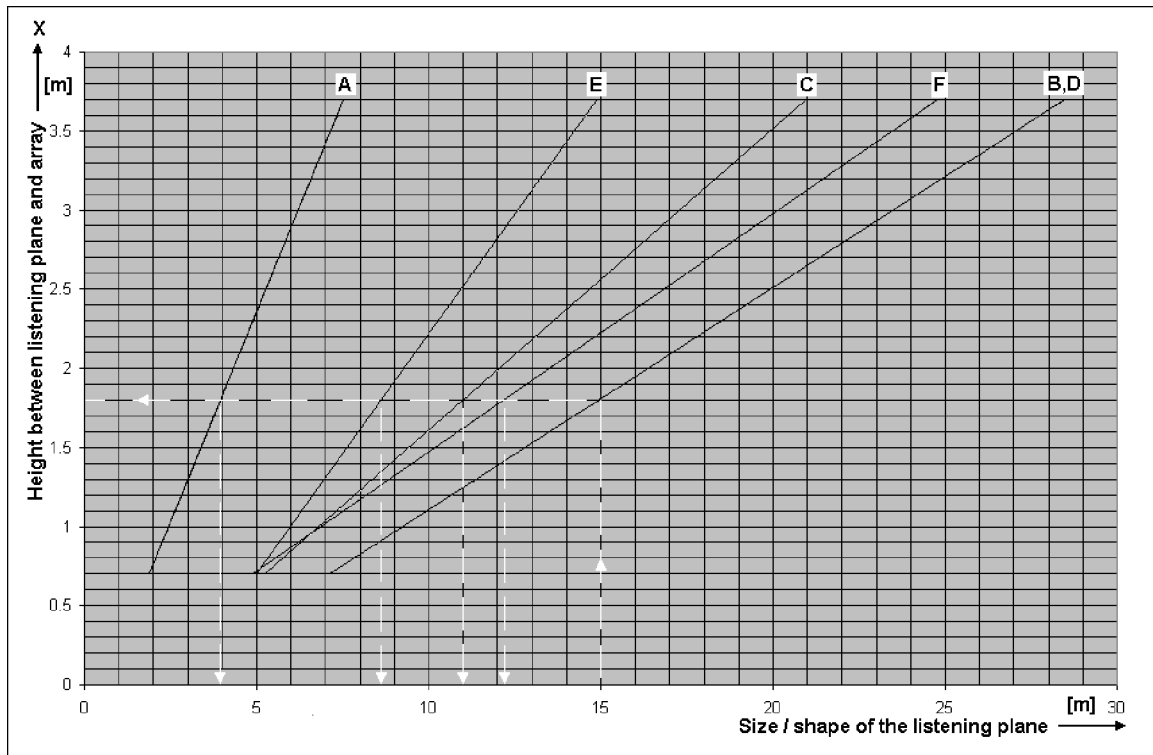
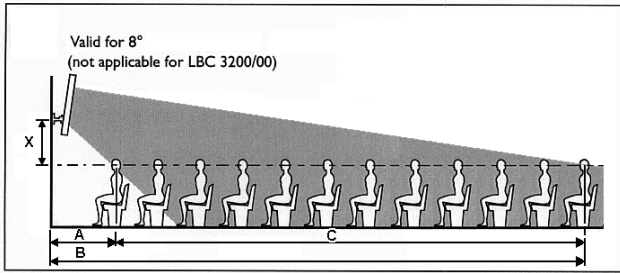

Figure 1: Vue latérale de l'émission sonore des haut-parleurs et du plan d'écoute

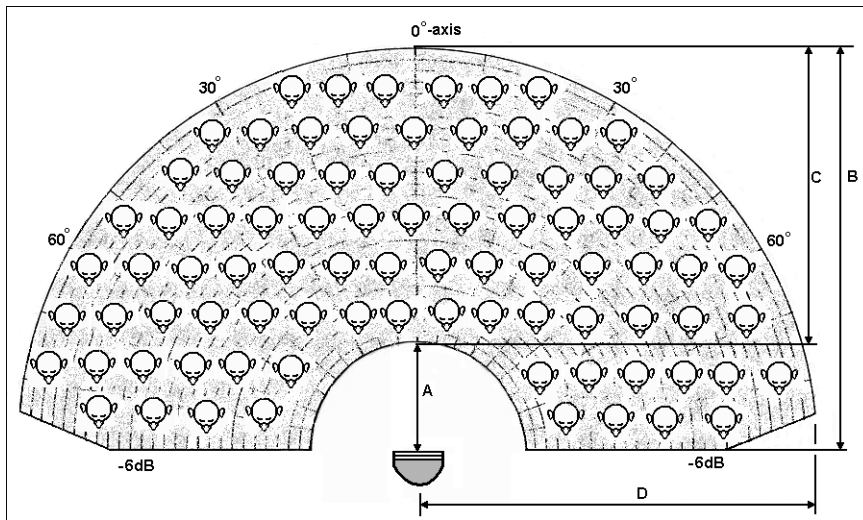

Figure 2: Forme de l'octave d'1 kHz des haut-parleurs

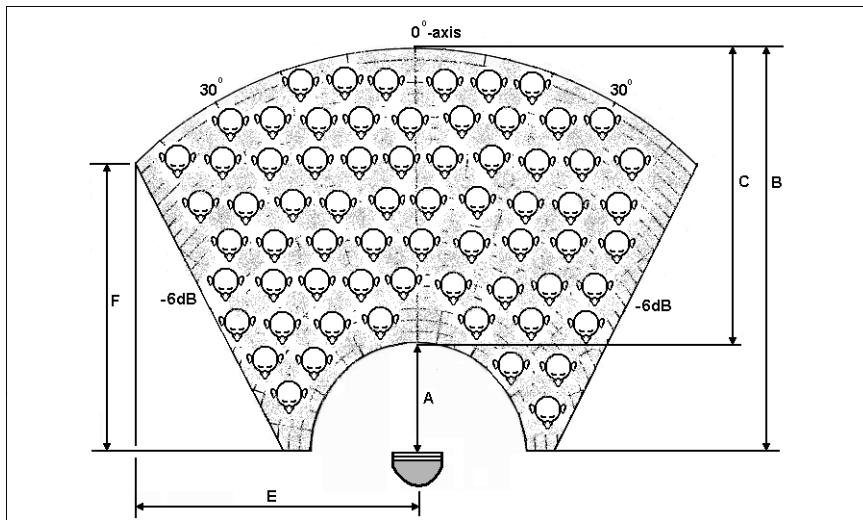

Figure 3: Forme de l'octave de 4 kHz des haut-parleurs

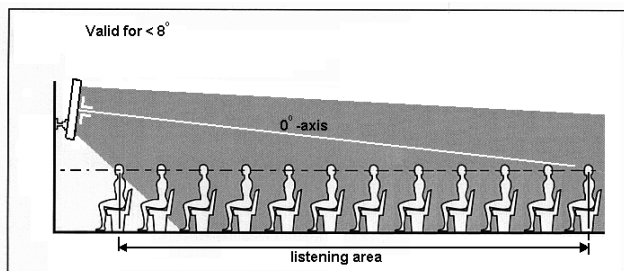
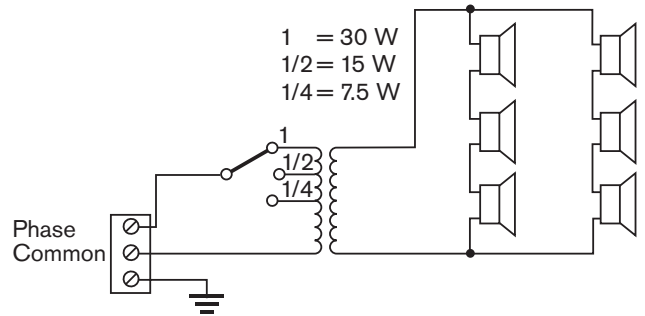
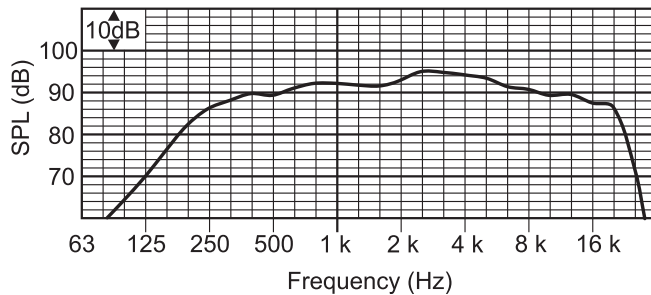

Figure 4: Orientation de l'axe à 0 degré des haut-parleurs vers la position maximale

DONNÉES TECHNIQUES

Puissance maximale	45 W
Puissance nominale	30 W (30-15-7,5 W)
Niveau de pression acoustique à	
30 W/1 W (à 1 kHz, 1 m)	106 dB/91 dB (NPA)
Bande de fréquences effective	
(-10 dB)	190 Hz à 18 kHz
Angle d'ouverture	
(à 1 kHz/4 kHz, -6 dB)	
Horizontal	220 ° /130 °
Vertical	70 ° /18 °
Tension d'entrée nominale	100 V
Impédance nominale	333 Ω
Température ambiante	-25 °C à +55 °C
Sécurité	conforme EN 60065
Connexion	bornier à vis
Dimensions (H x L x P)	600 x 80 x 90 mm
Couleur	argent
Poids	3 kg

**LBC 3200/00**

Bande d'octave (Hz)	250	500	1 k	2 k	4 k	8 k
NPA 1,1	87	89	91	93	93	89
NPA max.	102	104	106	108	108	104
Facteur Q	1,3	2,2	4,5	11,6	25,7	58,9
Angle hor. (deg)	360	360	220	190	130	100
Angle vert. (deg)	360	120	70	32	18	10

Horizontal

Vertical

LBC 3200/00
250Hz horizontal

LBC 3200/00
250Hz vertical

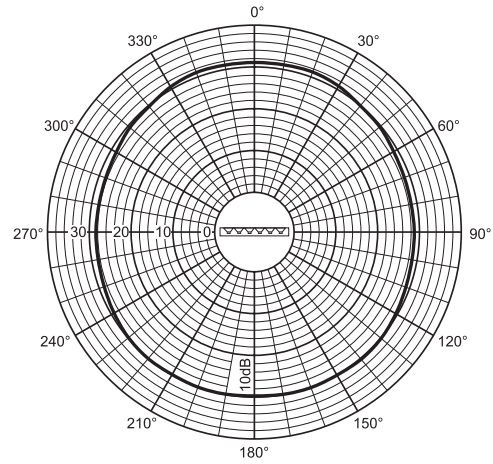
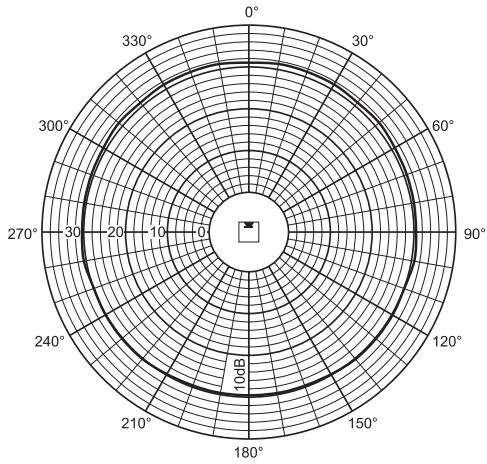

LBC 3200/00
500Hz horizontal

LBC 3200/00
500Hz vertical

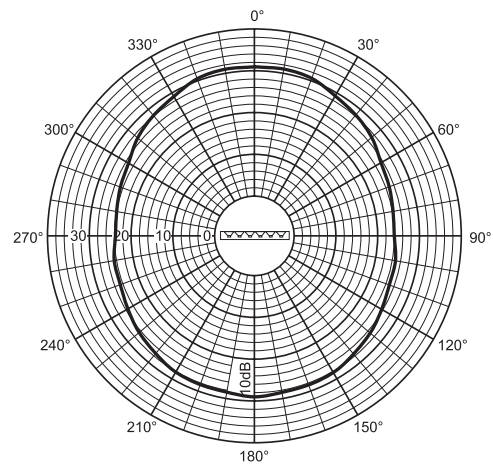
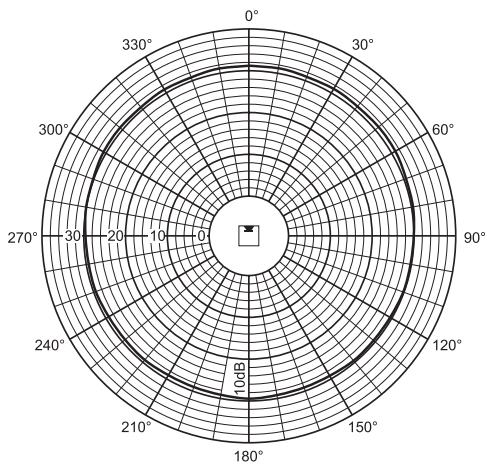

LBC 3200/00
1kHz horizontal

LBC 3200/00
1kHz vertical

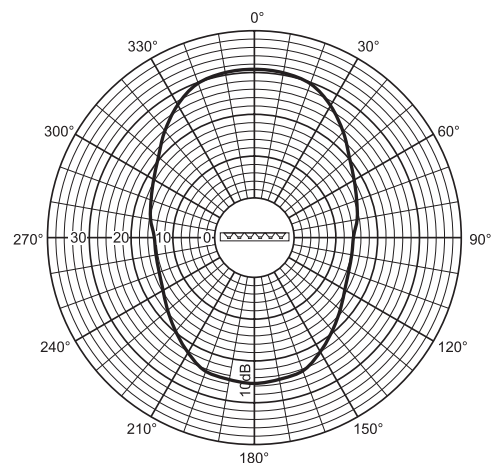
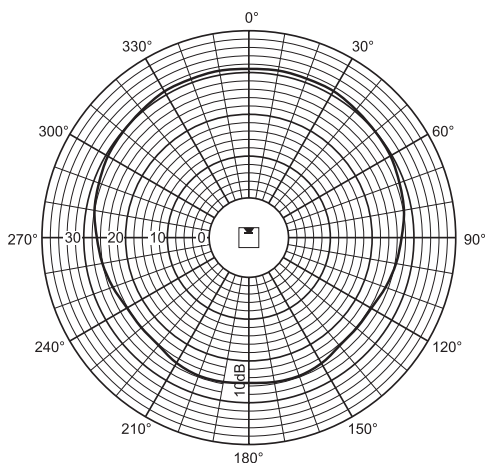

Horizontal

Vertical

LBC 3200/00
2kHz horizontal

LBC 3200/00
2kHz vertical

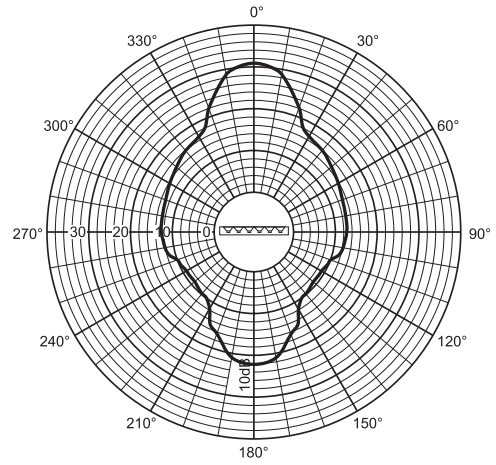
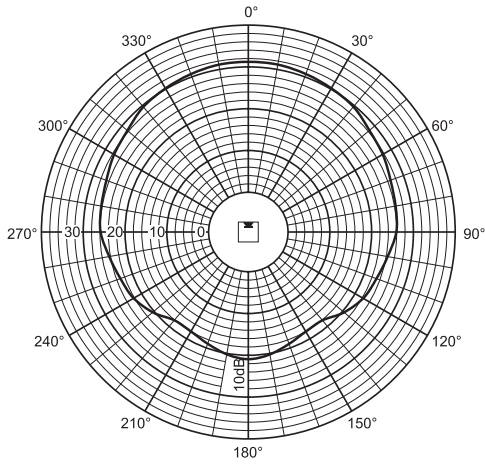

LBC 3200/00
4kHz horizontal

LBC 3200/00
4kHz vertical

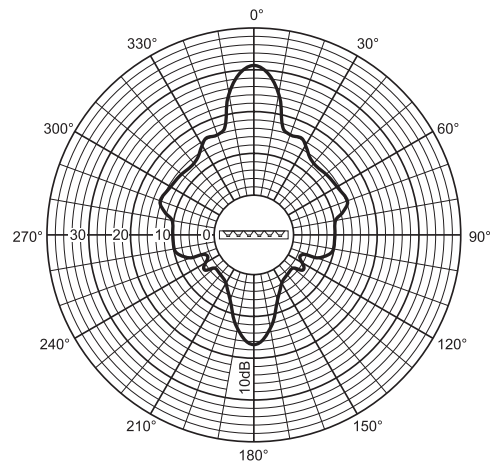
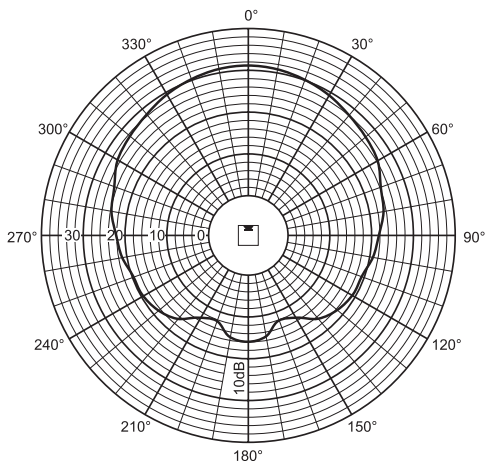

LBC 3200/00
8kHz horizontal

LBC 3200/00
8kHz vertical

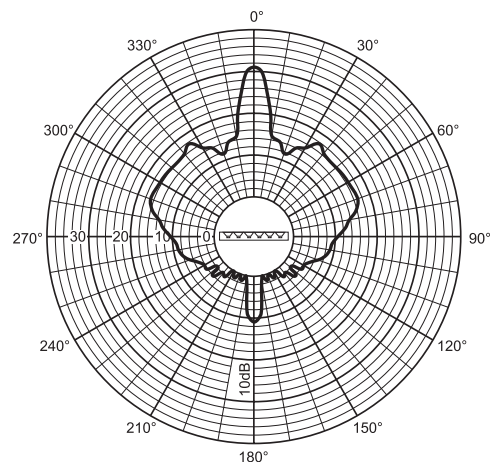
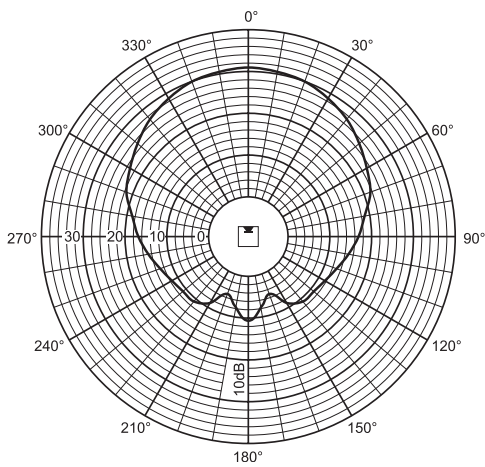

DONNÉES TECHNIQUES

LBC 3201/00

Puissance maximale	90 W
Puissance nominale	60 W (60-30-15 W)
Niveau de pression acoustique à	
60 W/1 W (à 1 kHz, 1 m)	110 dB/92 dB (NPA)
Bande de fréquences effective	
(-10 dB)	190 Hz à 18 kHz
Angle d'ouverture	
(à 1 kHz / 4 kHz, - 6 dB)	
Horizontal	210 °/132 °
Vertical	50 °/22 °
Tension d'entrée nominale	100 V
Impédance nominale	167 Ω
Température ambiante	-25 °C à +55 °C
Sécurité	conforme EN 60065
Connexion	bornier à vis
Dimensions (H x L x P)	1200 x 80 x 90 mm
Couleur	argent
Poids	6,4 kg

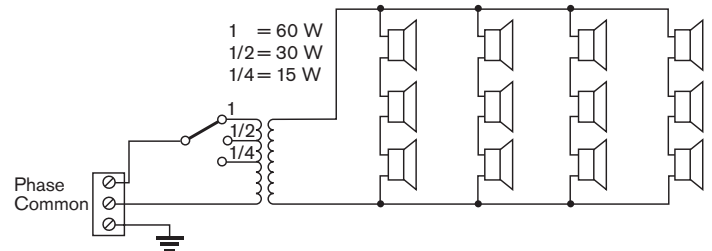
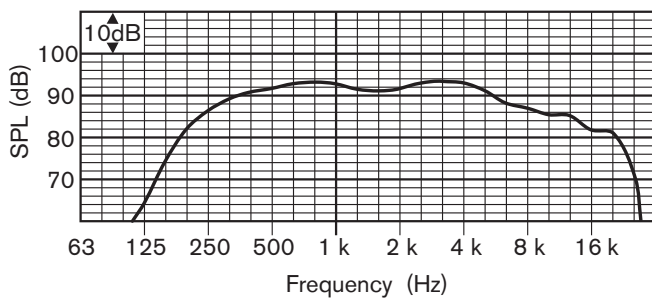

LBC 3201/00

Bande d'octave (Hz)	250	500	1 k	2 k	4 k	8 k
NPA 1,1	88	92	92	91	91	86
NPA max.	106	110	110	109	109	104
Facteur Q	2,2	3,2	6,5	12,6	23,4	53,3
Angle hor. (deg)	360	360	210	192	132	100
Angle vert. (deg)	107	67	50	33	22	12

Horizontal

Vertical

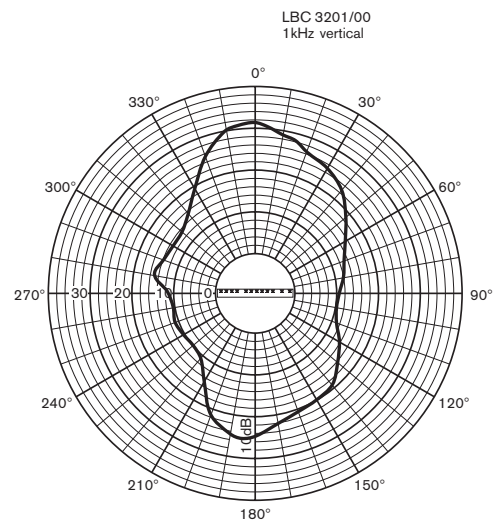
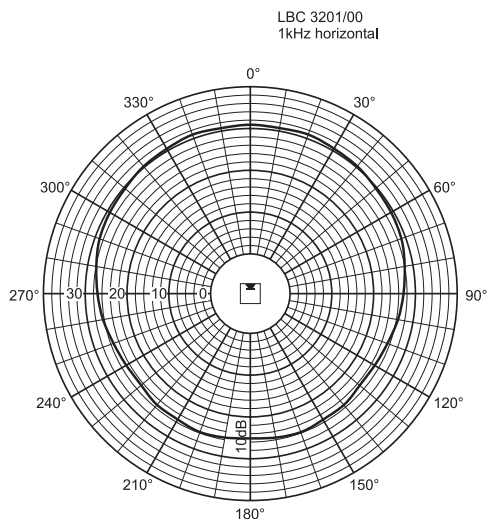
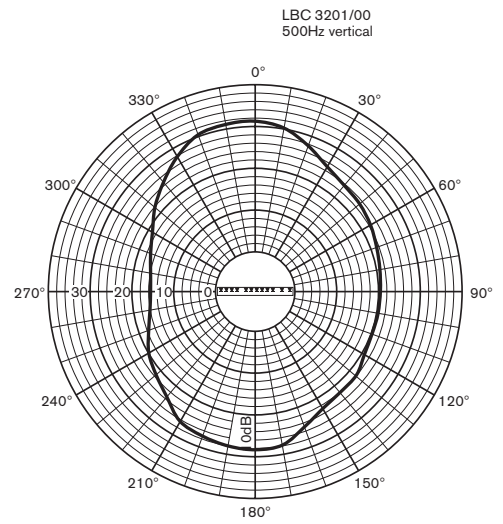
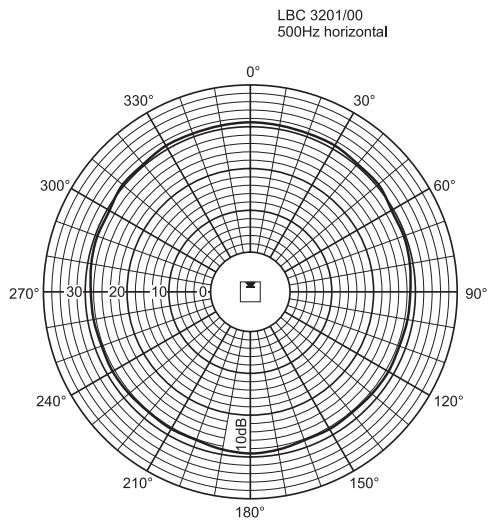
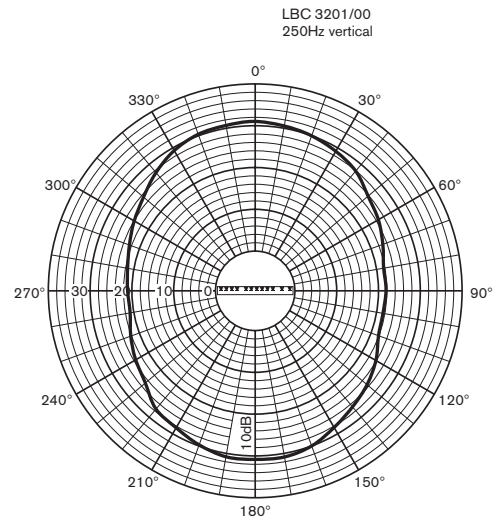
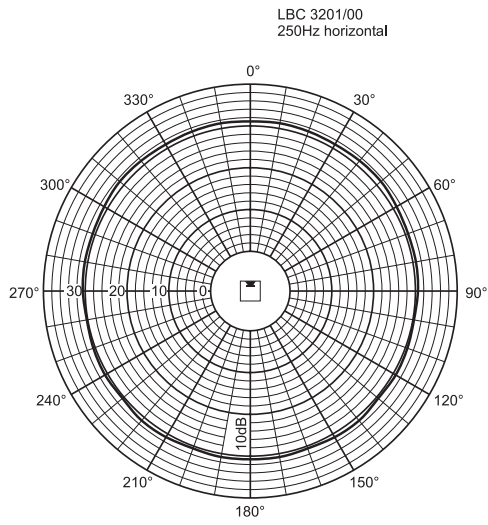

Horizontal

Vertical

LBC 3201/00
2kHz horizontal

LBC 3201/00
2kHz vertical

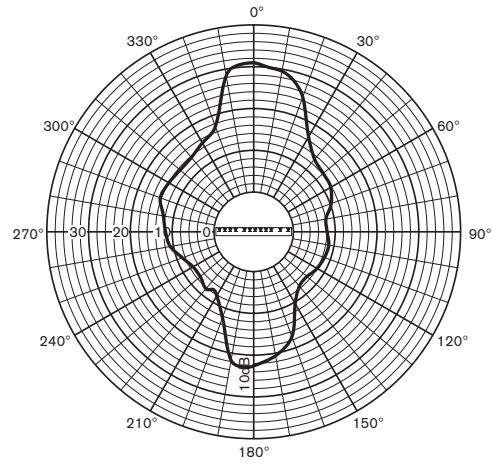
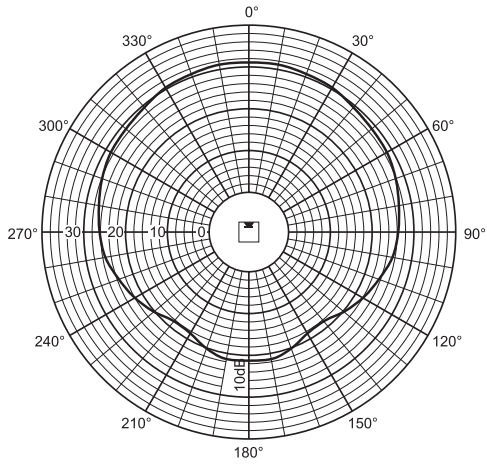

LBC 3201/00
4kHz horizontal

LBC 3201/00
4kHz vertical

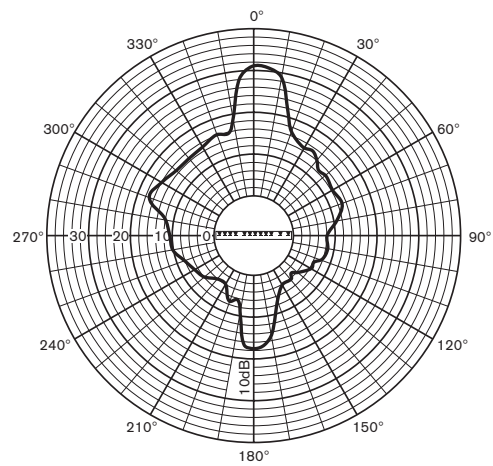
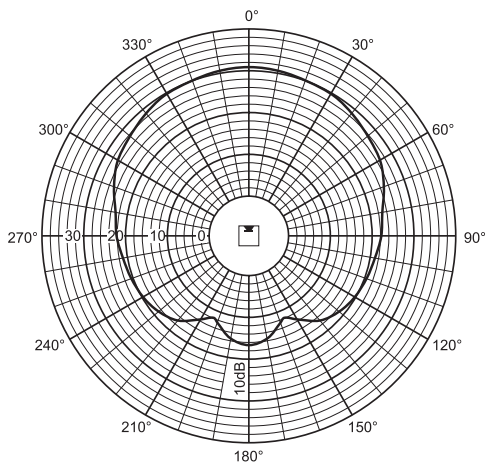

LBC 3201/00
8kHz horizontal

LBC 3201/00
8kHz vertical

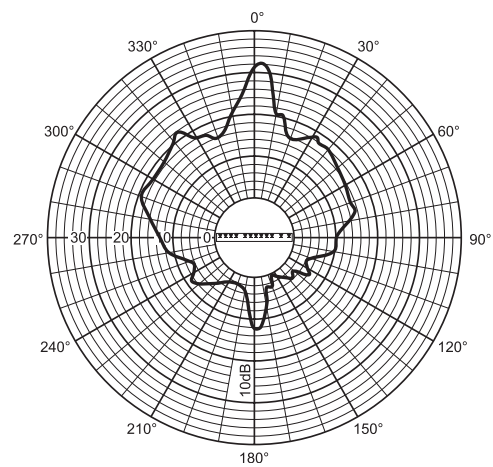
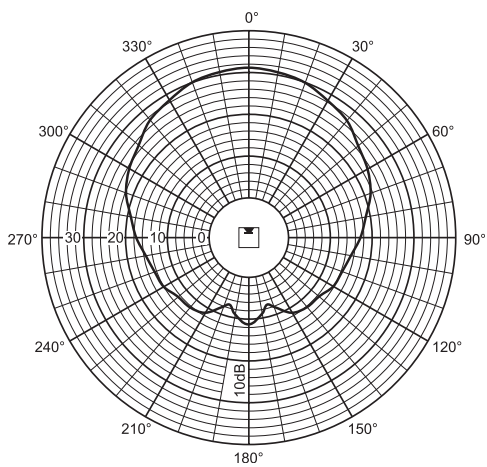

DONNÉES TECHNIQUES**LBC 3210/00**

Puissance maximale	90 W
Puissance nominale	60 W (60-30-15 W)

Niveau de pression acoustique	
à 60 W/1 W (à 1 kHz, 1 m)	115 dB/97 dB (NPA)

Bande de fréquences effective	
(-10 dB)	190 Hz à 20 kHz

Angle d'ouverture	
(à 1 kHz / 4 kHz, - 6 dB)	

Horizontal	170 °/90 °
Vertical	55 °/18 °

Tension d'entrée nominale	100 V
----------------------------------	-------

Impédance nominale	167 Ω
---------------------------	-------

Température ambiante	-25 °C à +55 °C
-----------------------------	-----------------

Sécurité	conforme EN 60065
-----------------	-------------------

Protection contre l'eau et la poussière	IP 66 conforme IEC 60529
--	--------------------------

Connexion	bornier à vis
------------------	---------------

Dimensions (H x L x P)	1 200 x 160 x 90 mm
-------------------------------	---------------------

Couleur	argent
----------------	--------

Poids	9 kg
--------------	------

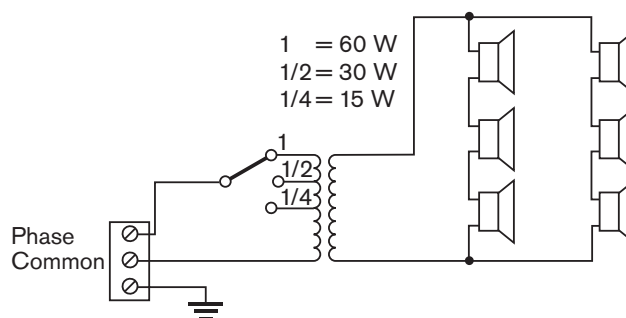
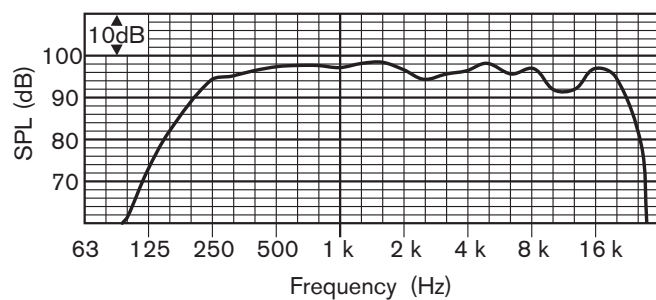
**LBC 3210/00**

Bande d'octave (Hz)	250	500	1 k	2 k	4 k	8 k
NPA 1,1	94	97	97	95	96	93
NPA max.	112	115	115	113	114	111
Facteur Q	2,2	2,7	6,3	10,8	22,6	32,3
Angle hor. (deg)	360	180	170	160	90	60
Angle vert. (deg)	100	60	55	34	18	10

Horizontal

Vertical

LBC 3210/00
250Hz horizontal

LBC 3210/00
250Hz vertical

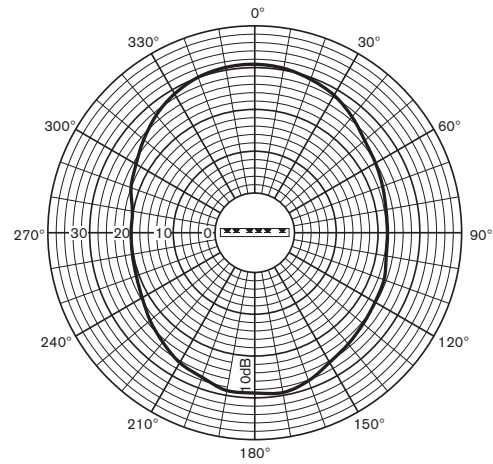
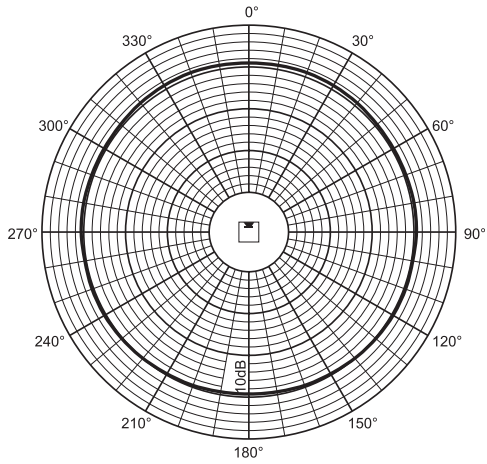

LBC 3210/00
500Hz horizontal

LBC 3210/00
500Hz vertical

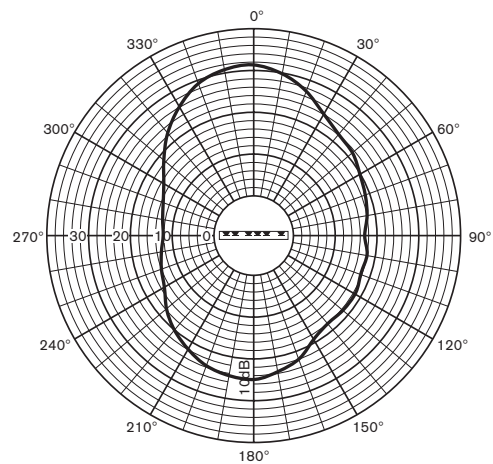
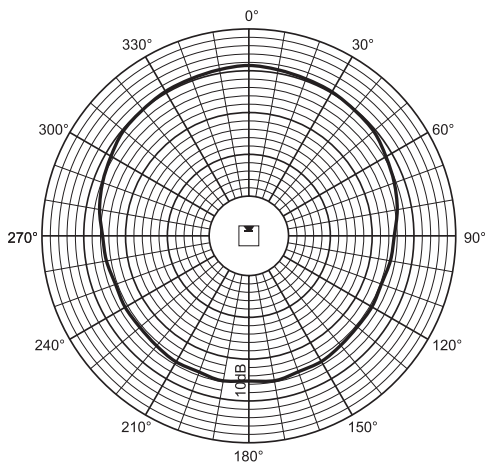

LBC 3210/00
1kHz horizontal

LBC 3210/00
1kHz vertical

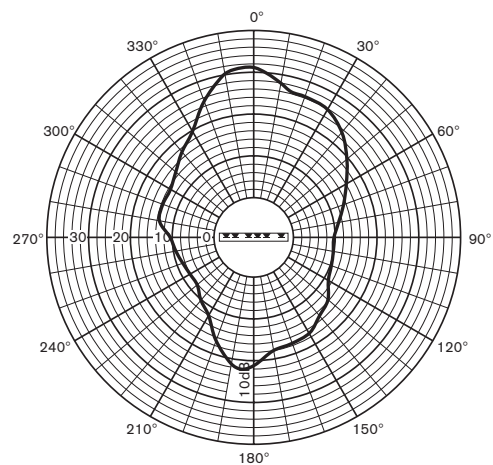
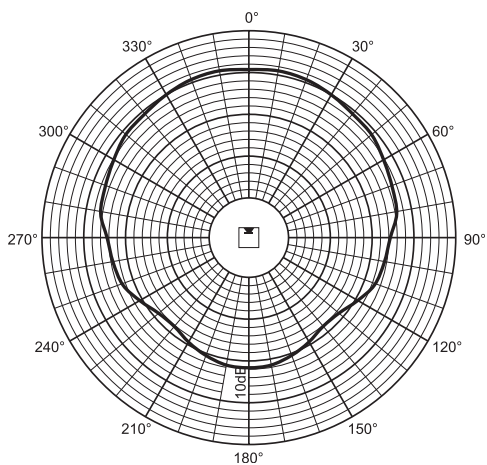

Horizontal

Vertical

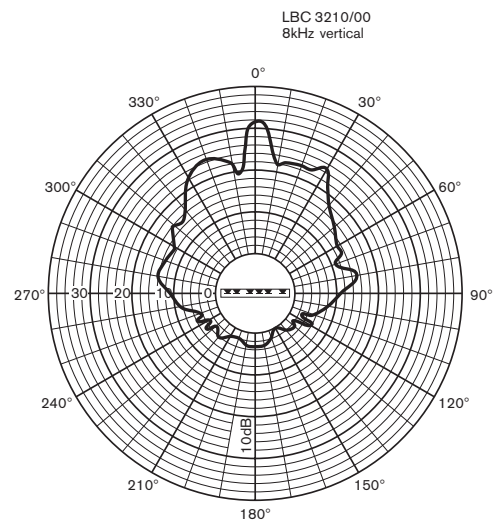
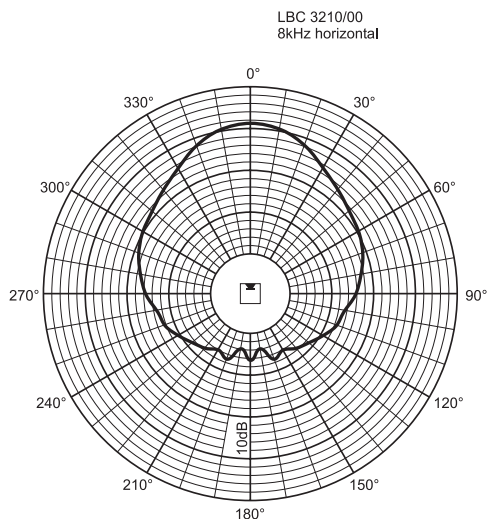
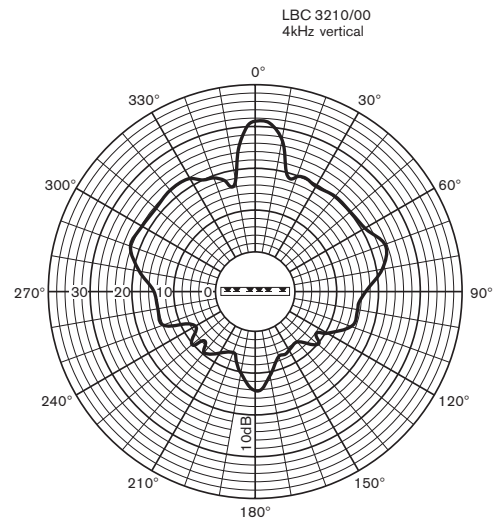
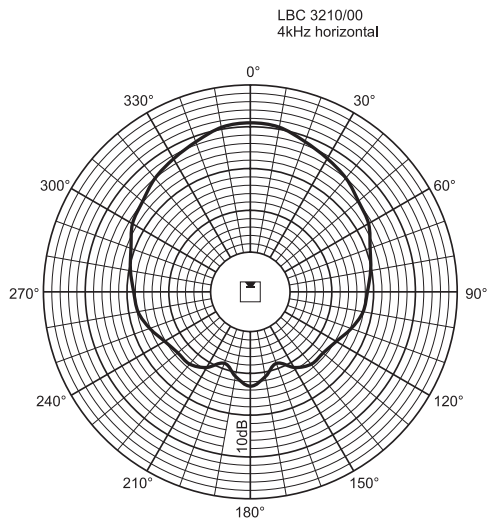
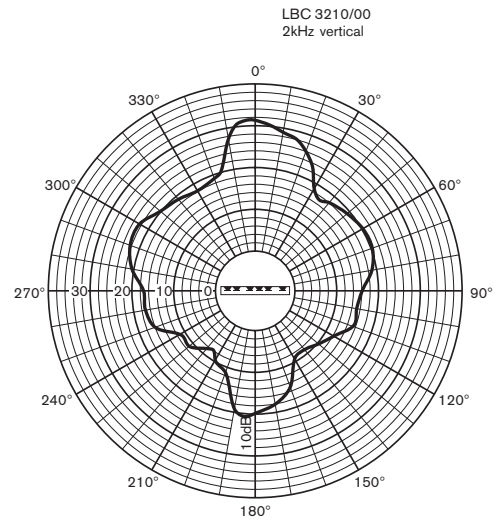
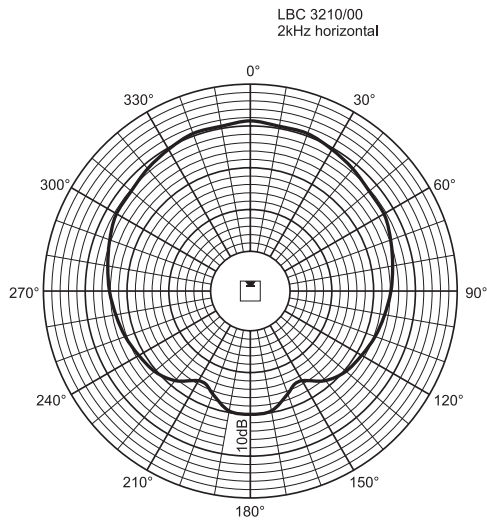

www.boschsecuritysystems.com

BOSCH

Inhalt	Seite
Installationshandbuch (Abb. 1 - Abb. 17)	50
Montage der Leitungs-/Lautsprecherüberwachungsplatine (optional) (Abb. A1 - Abb. A5)	52
Montage der Zusatzhalterung (optional) (Abb. B1 - Abb. B5)	52
Montage des Bodenständers (optional) (Abb. C1 - Abb. C3)	52
Hörbereich und entsprechende Montagehöhe für LBC 3200/00	53
Hörbereich und entsprechende Montagehöhe für LBC 3201/00	55
Hörbereich und entsprechende Montagehöhe für LBC 3210/00	58
Technische Daten LBC 3200/00	61
Technische Daten LBC 3201/00	64
Technische Daten LBC 3210/00	67

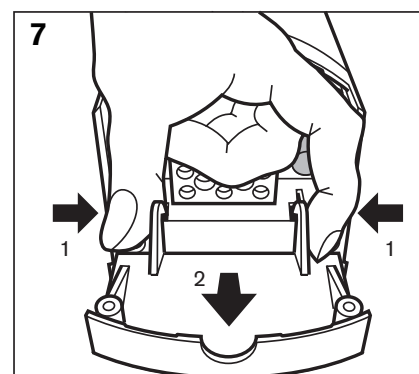
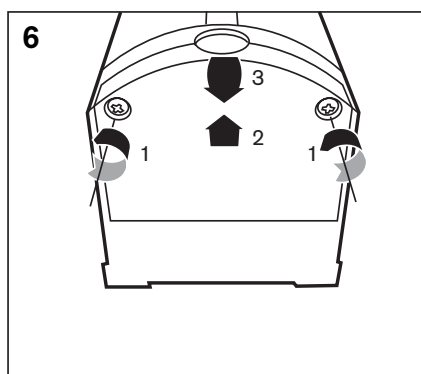
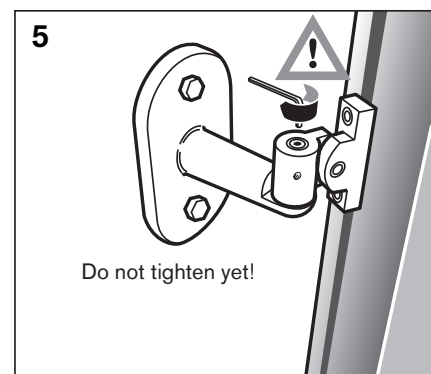
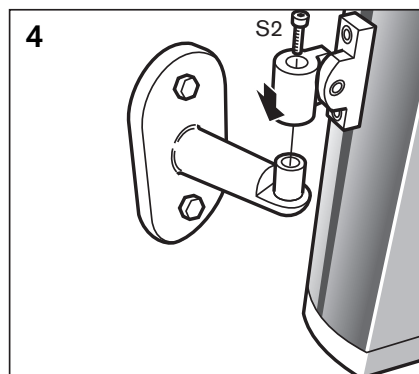
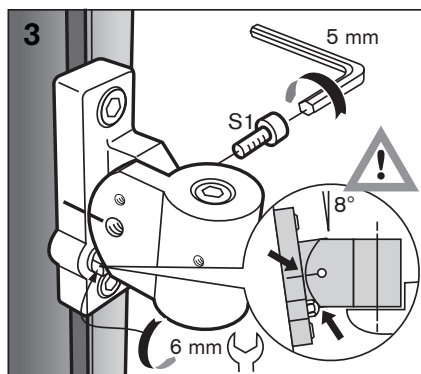
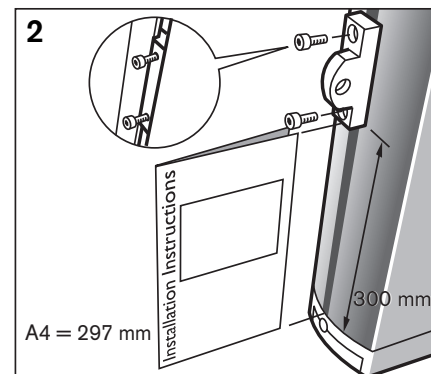
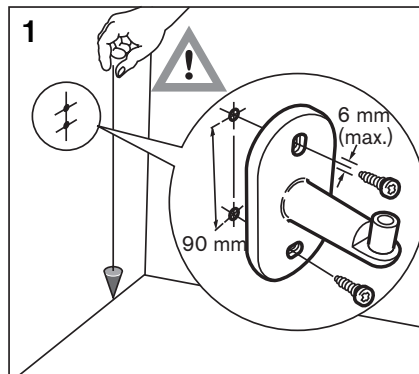
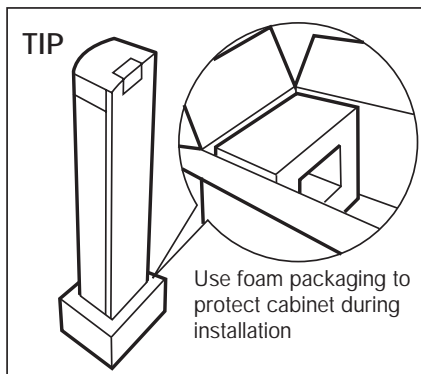
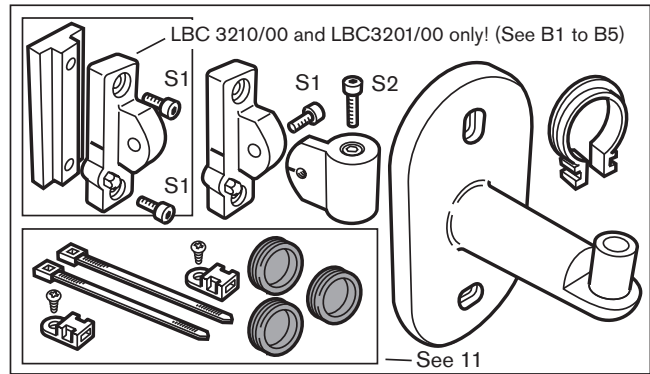
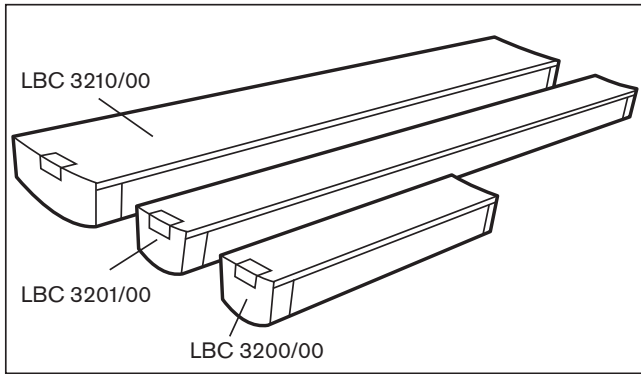

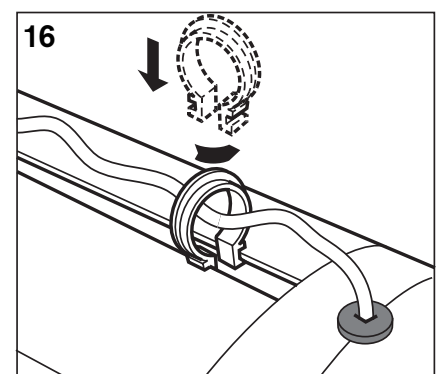
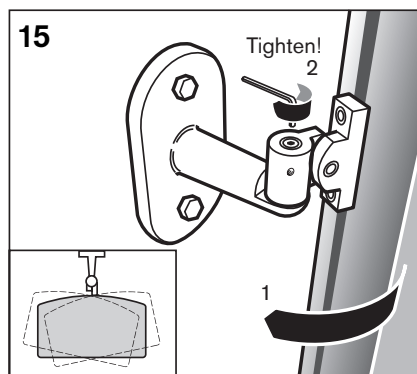
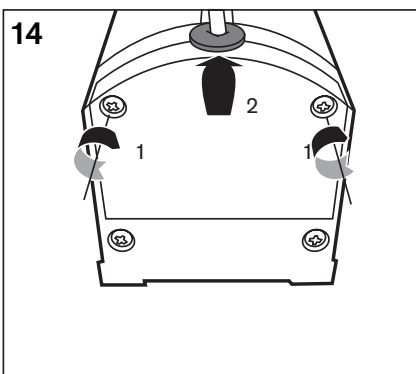
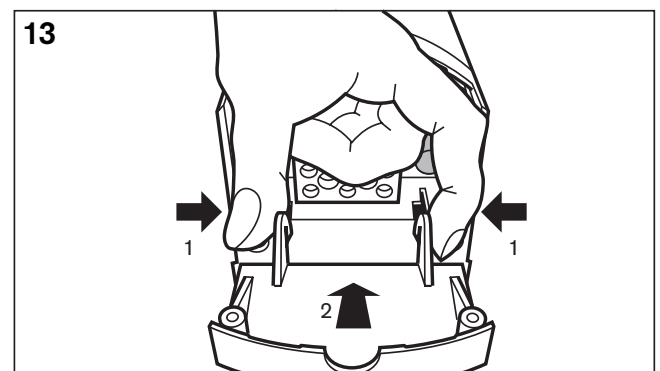
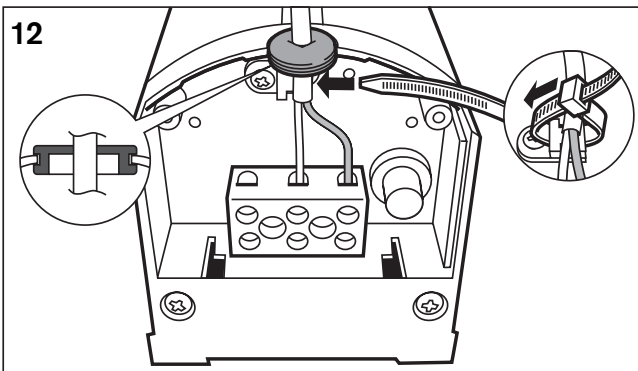
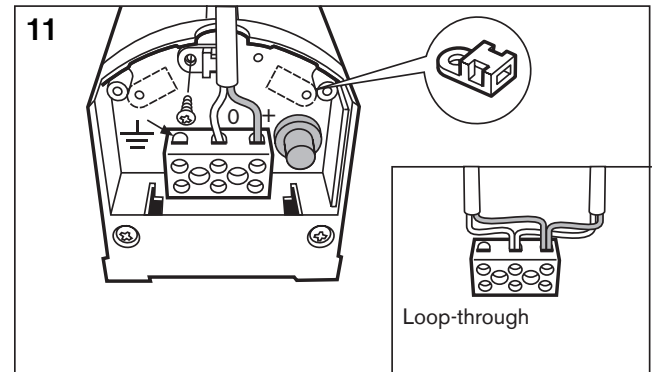
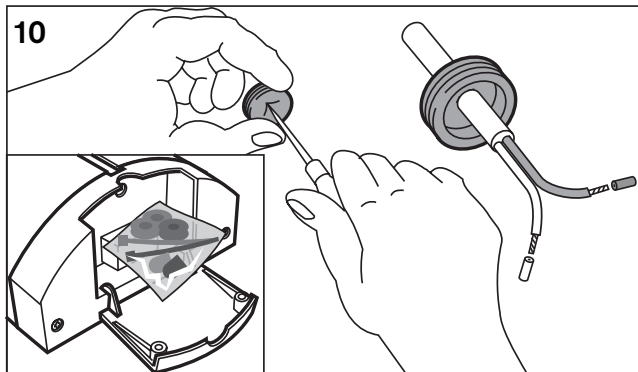
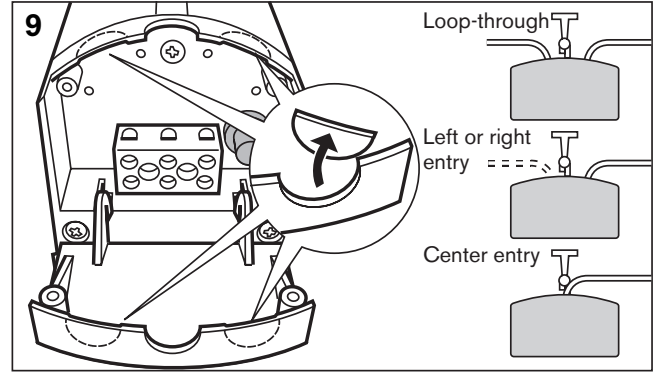
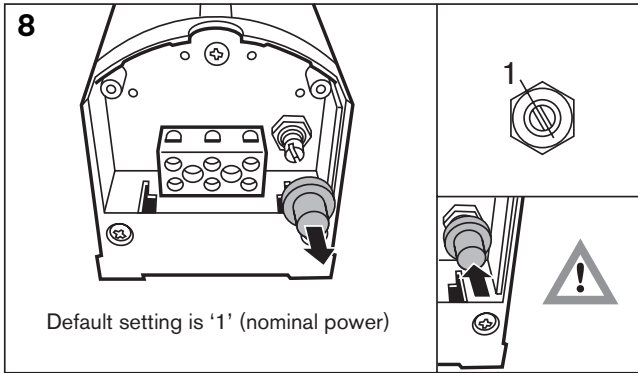

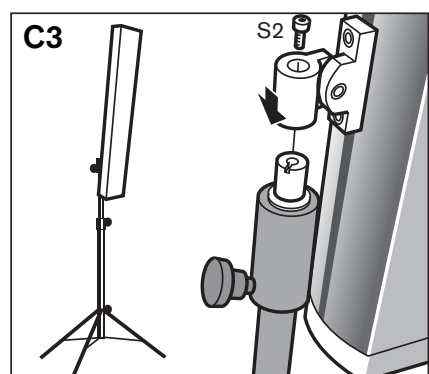
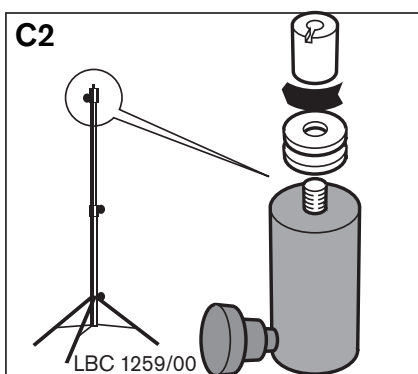
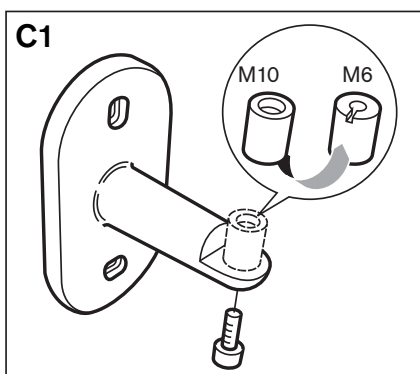
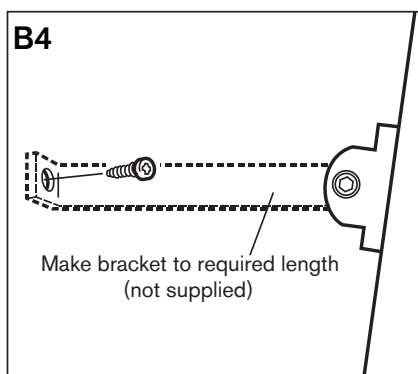
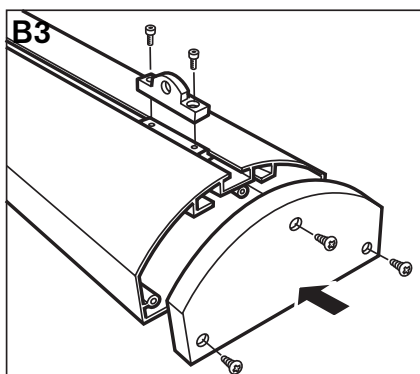
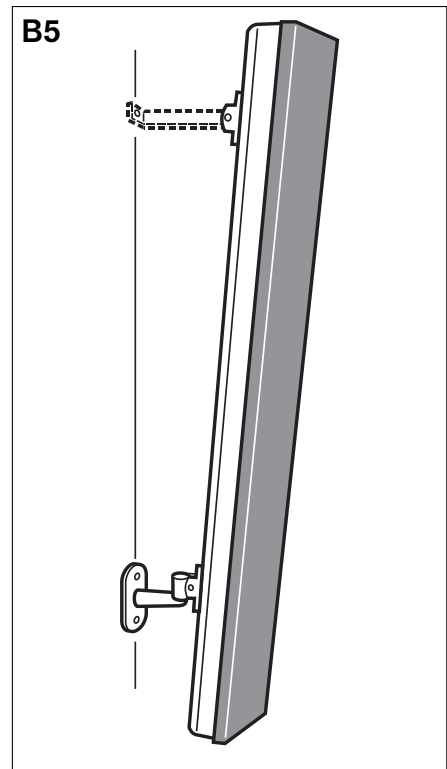
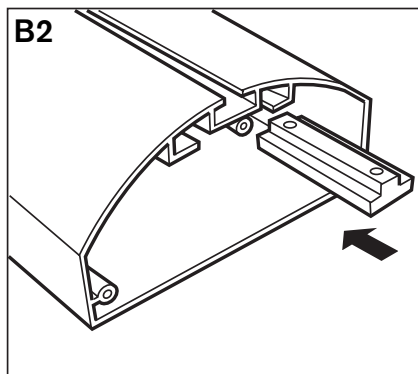
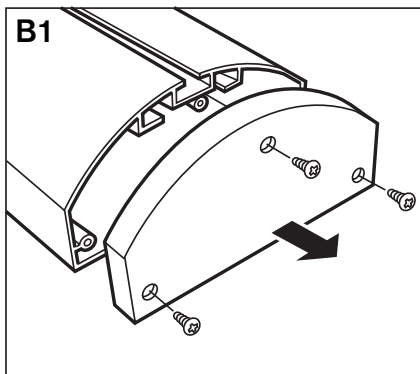
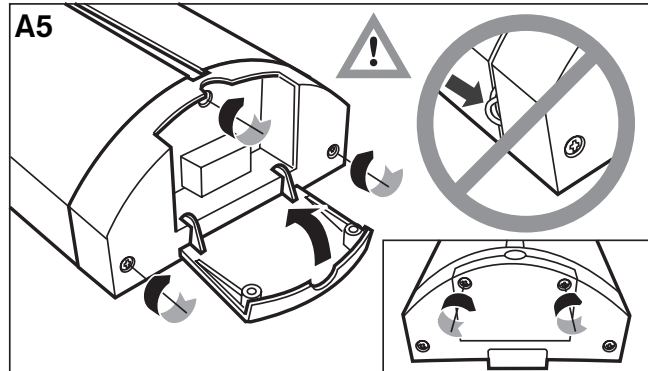
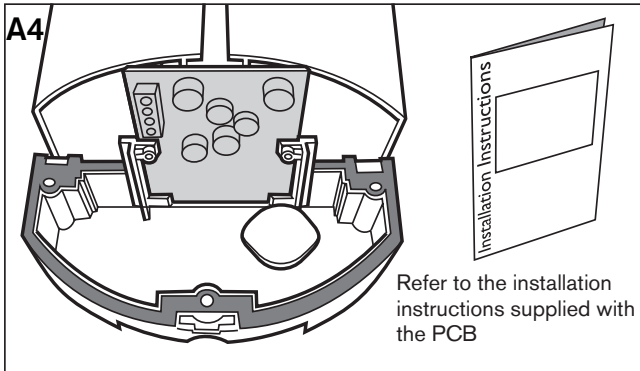
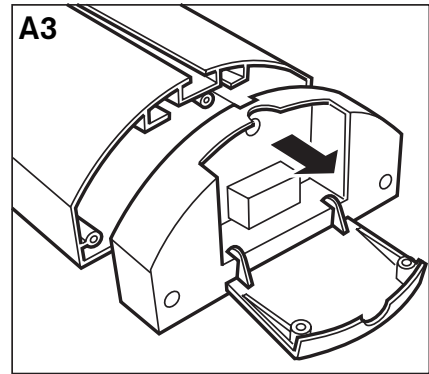
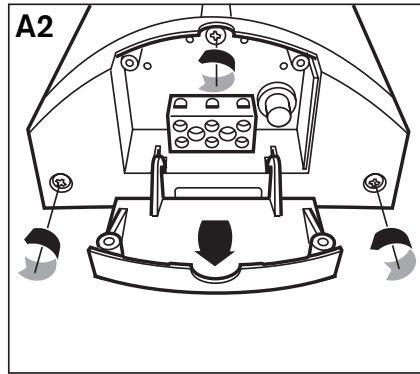
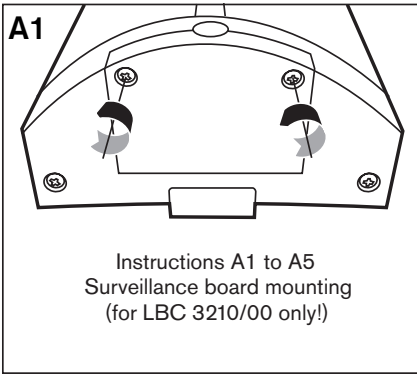

Hörbereich und entsprechende Montagehöhe für XLA3200/00

Bestimmen der Montagehöhe und des Montagewinkels für die LBC3200-Lautsprechereinheit:

- Bestimmen Sie die Abmessungen des gewünschten Hörbereichs (eine horizontale Ebene auf Ohrenhöhe der Zuhörer – siehe gestrichelte Linie in Abbildung 1).
- Bestimmen Sie den Winkel, in dem die Lautsprechereinheit montiert werden soll. Die Einheit ist so ausgelegt, dass der Schall unmittelbar über den Köpfen der Zuhörer ausgestrahlt werden soll. Der Winkel sollte nicht größer als 6° sein. Zwei Ansätze sind möglich, die jeweils ihre eigenen Vor- und Nachteile haben.
 - Ansatz 1: Möglichst großer Hörbereich
Wenn Sie einen großen Hörbereich wünschen, wird ein Winkel von rund 3° empfohlen (siehe Abbildung 1). Wie stark sich der Schalldruckpegel mit zunehmender Entfernung von der Lautsprechereinheit verringert, hängt vom Raumhall ab. Um hohe Töne klar hören zu können, sollte der Zuhörer Sichtkontakt zur Lautsprechereinheit haben.
 - Ansatz 2: Möglichst geringe Variationen im Schalldruckpegel
Wenn weniger Variationen im Schalldruckpegel gewünscht werden, wird ein Winkel von 5° empfohlen. Dadurch ergibt sich ein kleinerer Gesamthörbereich als bei Ansatz 1, und der Bereich in unmittelbarer Nähe der Lautsprechereinheit („A“ in Abbildung 2) liegt außerhalb des Hörbereichs. Diagramm 1 zeigt die Beziehung zwischen „A“ und der Montagehöhe der Lautsprechereinheit bei einem Installationswinkel von 5°.
- Nachdem Sie sich für den geeigneten Ansatz (Montagewinkel) entschieden haben, bestimmen Sie die Montagehöhe der Lautsprecher, indem Sie die 0°-Achse der Lautsprechereinheit auf die gewünschte Position unmittelbar über der Ohrhöhe des am weitesten entfernten Zuhörers richten. Montieren Sie dazu den Lautsprecher höher oder niedriger an der Wand. Nun können Sie die Lautsprechereinheit so montieren, dass sich eine optimale Akustikleistung ergibt.

Fragen und Antworten zur Installation

- Kann ich die Lautsprechereinheit LBC3200 genau wie LBC3210 oder LBC3201 installieren?**
Diese Lautsprechereinheit ist für kleine und mittlere Innenräume ausgelegt. Die optimale Akustikleistung dieser Lautsprechereinheit erhalten Sie, indem Sie den Schall unmittelbar über Kopfhöhe der Zuhörer ausstrahlen. Wenn diese Lautsprechereinheit wie LBC3210 oder LBC3201 montiert wird, erhalten Sie einen sehr kleinen Hörbereich. Aus dem gleichen Grund sollten Sie keinen Winkel über 6° wählen.

- Wenn ich die Lautsprechereinheit nicht sehen kann, bedeutet das, dass ich hohe Töne nicht hören kann?**
Hohe Töne können mit Licht verglichen werden. Wenn zwischen Ihnen und der Lichtquelle ein Hindernis steht, sehen Sie die Lichtquelle nicht in ihrer vollen Leistung. Das wird als Schatten bezeichnet. Bei hohen Tönen ergibt sich der gleiche Effekt. Wenn viele Personen zwischen Ihnen und dem Lautsprecher sitzen, befinden Sie sich im Schallschatten. Das macht sich durch leisere hohe Töne bemerkbar.

Hintergrundinformationen:

- Aufgrund der vielen möglichen Installationswinkel ist es schwierig, eine definitive Form des von der Lautsprechereinheit abgestrahlten Schalls anzugeben.
- Wenn Sie die Lautsprechereinheit in einem kleinen Winkel installieren, erhalten Sie einen (sehr) großen Hörbereich. Abhängig von Raumhall und Schallschatten (Personen oder Objekten vor einem Zuhörer, die die direkte Schallquelle blockieren) können weit entfernt sitzende Zuhörer einen Redner möglicherweise nur schwer verstehen. In diesem Fall ist es besser, mehrere Lautsprechereinheiten zu verwenden und den Hörbereich so aufzuteilen.
- Wenn Sie sich aus dem Hörbereich herausbewegen (über die maximale Entfernung von der Lautsprechereinheit hinaus), verringert sich lediglich der Schalldruckpegel. Variationen der Tonhöhe treten fast nicht auf. Wie stark der Schalldruckpegel abnimmt, hängt besonders vom Raumhall ab.
- Wenn Sie sich zu nahe an der Lautsprechereinheit befinden (weniger als die Mindestentfernung von der Lautsprechereinheit) und den 5°-Ansatz verwenden, werden hohe Töne sehr schnell beeinträchtigt.
- Da die Lautsprecher so ausgelegt sind, dass der Schall unmittelbar über der Kopfhöhe der Zuhörer abgestrahlt werden soll, sollten die Lautsprecher nicht zu hoch über dem Hörbereich montiert werden.
- Die Ränder des Hörbereichs in einer gegebenen Situation können nur durch einen praktischen Test in dem Raum, in dem die Lautsprechereinheit installiert wird, genau bestimmt werden. Diese Aufgabe muss von einem erfahrenen Zuhörer mit einem gut ausgebildeten Gehör ausgeführt werden. Spielen Sie dazu rosa Rauschen über die Lautsprechereinheit ein. Für diesen Test sollten Sie die tieferen Töne reduzieren, da sie nicht zur Sprachverständlichkeit beitragen. Bewegen Sie sich im Hörbereich, und hören Sie sich die hohen Töne an. Die Ränder des Hörbereichs befinden sich dort, wo die hohen Töne sehr schnell abnehmen.



Abbildung 1: Abstrahlung der Lautsprechereinheit in Seitenansicht Wandmontage in kleinem Winkel



Abbildung 2: Abstrahlung der Lautsprechereinheit in Seitenansicht Wandmontage in 5°-Winkel

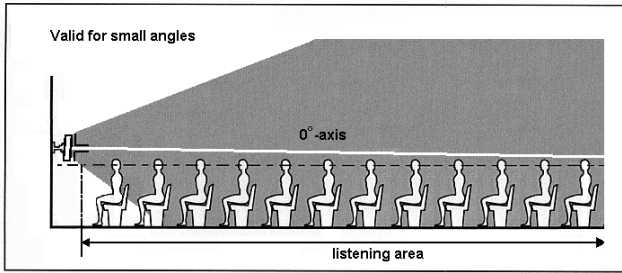

Diagramm 1: Beziehung zwischen Hörbereichsentfernung und Lautsprechereinheit

Hörbereich und entsprechende Montagehöhe für XLA3201/00

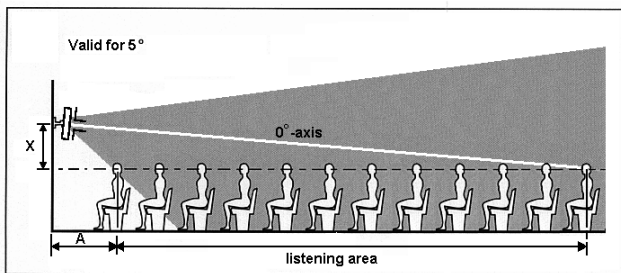
So verwenden Sie diese Montagemethode

- Bestimmen Sie die Abmessungen des gewünschten Hörbereichs (eine horizontale Ebene auf Ohrenhöhe der Zuhörer – siehe gestrichelte Linie in Abbildung 1).
- Messen Sie die maximale Entfernung von der Lautsprechereinheit zum letzten Zuhörer im Hörbereich (d. h. „B“ in den Abbildungen 1, 2 und 3).
- Gehen Sie in Diagramm 1 von der maximalen Entfernung auf der horizontalen Achse nach oben. Gehen Sie vom vertikalen Schnittpunkt mit der diagonalen B-Linie horizontal zur vertikalen Achse. Der X-Wert (Höhe der Montagehalterung der Lautsprechereinheit über der Hörebene, „X“ in Abbildung 1) steht auf dieser Achse. Die horizontalen Schnittpunkte mit anderen diagonalen Linien geben Informationen zu den Abmessungen des Hörbereichs an. Diese Werte beziehen sich auf die Abbildungen 2 und 3 (siehe auch das Beispiel unten).
- Abbildung 2 zeigt die 1 kHz-Oktavenform, die von der Lautsprechereinheit abgestrahlt wird, und Abbildung 3 zeigt die Abstrahlung der 4 kHz-Oktavenform. Der Hörbereich mit der optimalen Akustikleistung liegt in diesen Formen. Stellen Sie sicher, dass die 4 kHz-Form mit den mithilfe von Diagramm 1 ermittelten Abmessungen den gewünschten Hörbereich ausreichend abdeckt.
- Wenn der gewünschte Hörbereich von der 4 kHz-Form abgedeckt wird, zeigt der X-Wert auf der vertikalen Achse, wie hoch die Lautsprechereinheit über der Hörebene montiert werden muss. Beachten Sie dabei, dass die Lautsprechereinheit in der gewählten Höhe in einem Winkel von 8° montiert werden muss.

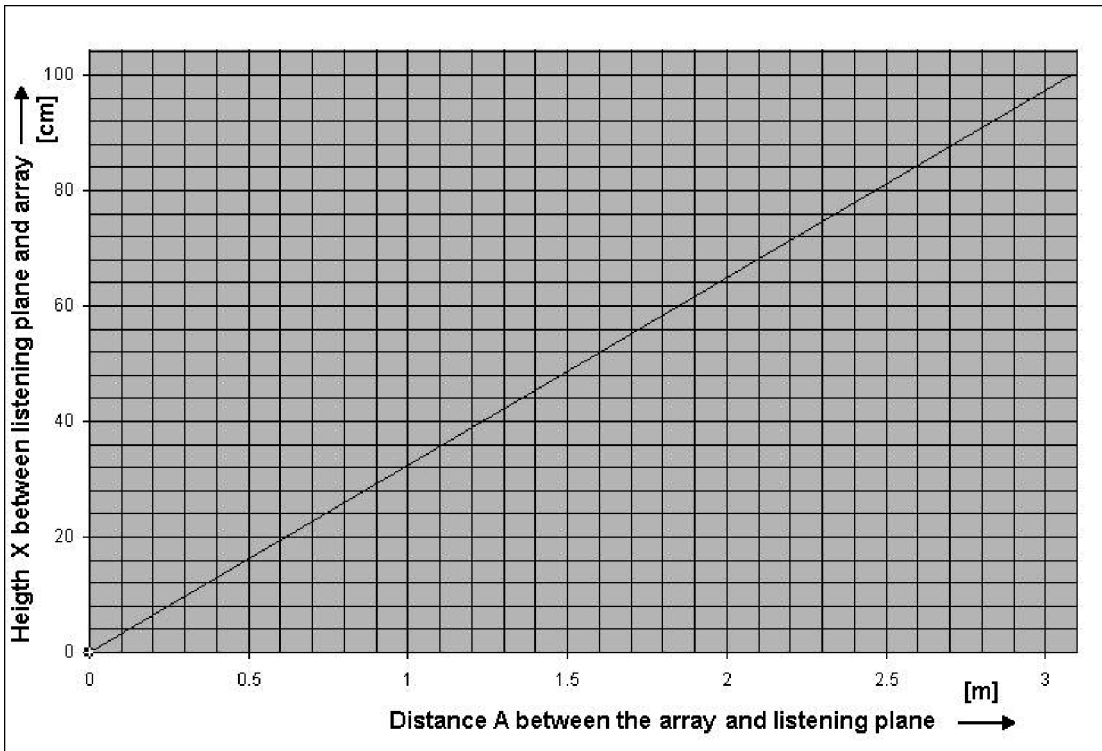
Nun können Sie die Lautsprechereinheit so montieren, dass sich eine optimale Akustikleistung ergibt.

Beispiel:

Die maximale Entfernung von der Lautsprechereinheit zum letzten Zuhörer beträgt 15 m. Wenn Sie vom 15 m-Punkt auf der horizontalen Achse von Diagramm 1 zur diagonalen B-Linie nach oben und anschließend seitlich zur vertikalen Achse gehen, geben die Schnittpunkte mit den anderen diagonalen Linien die Abmessungen der Hörebene an. In diesem Beispiel:

F-Linie (Seitenlänge der Hörebene für 4 kHz) = 11,1 m

C-Linie (Länge der Hörebene) = 11 m

E-Linie (halbe Breite der Hörebene für 4 kHz) = 9,3 m

A-Linie (Mindestentfernung zur Hörebene) = 3,9 m

Auf der vertikalen Achse beträgt der X-Wert (die Höhe zwischen der Hörebene und der Montageklammer der Lautsprechereinheit) 1,8 m.

Fragen und Antworten zur Installation:

- **Der gewünschte Hörbereich ist zu groß und passt nicht in die 4 kHz-Form.**
Probieren Sie eine andere Montagehöhe für die Lautsprechereinheit aus, oder verwenden Sie mehr Lautsprechereinheiten, um einen größeren Hörbereich zu erhalten.
- **Warum muss ein 8°-Winkel für die Lautsprechereinheit verwendet werden?**
Die Abstrahlungsformen in den Abbildungen 2 und 3 gelten nur dann für die Abmessungen in Diagramm 1, wenn die Lautsprechereinheit in einem Winkel von 8° montiert ist. Nur in diesem Fall erhalten Sie einen konstanten Schalldruckpegel und Frequenzgang (Constant Directivity) im Hörbereich.
- **Kann ich die Lautsprechereinheit in einem anderen Winkel anbringen?**
Sie können die Lautsprechereinheiten auch in einem anderen Winkel anbringen, erhalten dann jedoch nicht die optimale Akustikleistung. **Beispielsweise treten im Hörbereich größere Variationen im Schalldruckpegel auf. Die Werte in Diagramm 1 gelten nicht für andere Winkel. Winkel über 8° werden grundsätzlich nicht empfohlen.**
- **Die Lautsprechereinheit kann nicht in der gewünschten Höhe montiert werden.**
Wenn die gewünschte Höhe nicht erreicht werden kann, z. B. weil die Decke zu niedrig ist, wählen Sie einen Winkel unter 8°. Richten Sie die 0°-Achse der Lautsprechereinheit auf die gewünschte maximale Position (siehe Abbildung 4). Beachten Sie, dass in diesem Fall die Tabelle in Diagramm 1 und die Formen in den Abbildungen 2 und 3 nicht gelten. Überprüfen Sie im Hörbereich, ob ein Redner deutlich genug zu verstehen ist.

Hintergrundinformationen:

- Die Formen wurden in einem schalltoten Raum definiert. In einem schalltoten Raum erhalten Sie mit diesen Formen maximal 6 dB Schalldruckvariation und eine bedeutend geringere Variation im wahrgenommenen Frequenzgang. In Bereichen mit normalem oder hohem Nachhall treten geringere Variationen des Schalldruckpegels auf, und die Formen sind größer. Der wahrgenommene Frequenzgang in dieser Form ist dann fast konstant.
- Wenn Sie sich aus dem Hörbereich herausbewegen (über die maximale Entfernung von der Lautsprechereinheit hinaus), verringert sich lediglich der Schalldruckpegel. Variationen der Tonhöhe treten fast nicht auf. Wie stark der Schalldruckpegel abnimmt, hängt stark vom Raumhall ab.

- Wenn Sie sich zu nahe an den Lautsprechereinheiten befinden (weniger als die Mindestentfernung von der Lautsprechereinheit), werden hohe Töne sehr schnell beeinträchtigt.
- Abhängig von Raumhall und Schallschatten (Personen oder Objekten vor einem Zuhörer, die die direkte Schallquelle blockieren) können die am weitesten entfernt sitzenden Zuhörer einen Redner möglicherweise nur schwer verstehen. In diesem Fall ist es besser, mehrere Lautsprechereinheiten zu verwenden und den Hörbereich so aufzuteilen.
- Die Seitenlinien der Formen in Abbildung 2 und 3 sind die -6 dB-Punkte zum Schalldruckpegel auf der 0° -Achse.
- Für eine optimale Verständlichkeit des Redners müssen Sie einen Hörbereich definieren, in dem die 4 kHz-Oktavenform den gesamten Bereich abdeckt.
- Die Ränder des Hörbereichs in einer gegebenen Situation können nur durch einen praktischen Test in dem Raum, in dem die Lautsprechereinheit installiert wird, genau bestimmt werden. Diese Aufgabe muss von einem erfahrenen Zuhörer mit einem gut ausgebildeten Gehör ausgeführt werden. Spielen Sie dazu rosa Rauschen über die Lautsprechereinheit ein. Für diesen Test sollten Sie die tieferen Töne reduzieren, da sie nicht zur Sprachverständlichkeit beitragen. Bewegen Sie sich im Hörbereich, und hören Sie sich die hohen Töne an. Die Ränder des Hörbereichs befinden sich dort, wo die hohen Töne sehr schnell abnehmen.



Diagramm 1: Beziehung zwischen Hörbereich und Montagehöhe der Lautsprechereinheit

Bedeutung der diagonalen Linien

B-Linie: Maximale Entfernung von der Lautsprechereinheit zum letzten Zuhörer

D-Linie: Halbe Breite der Hörebene für 1 kHz

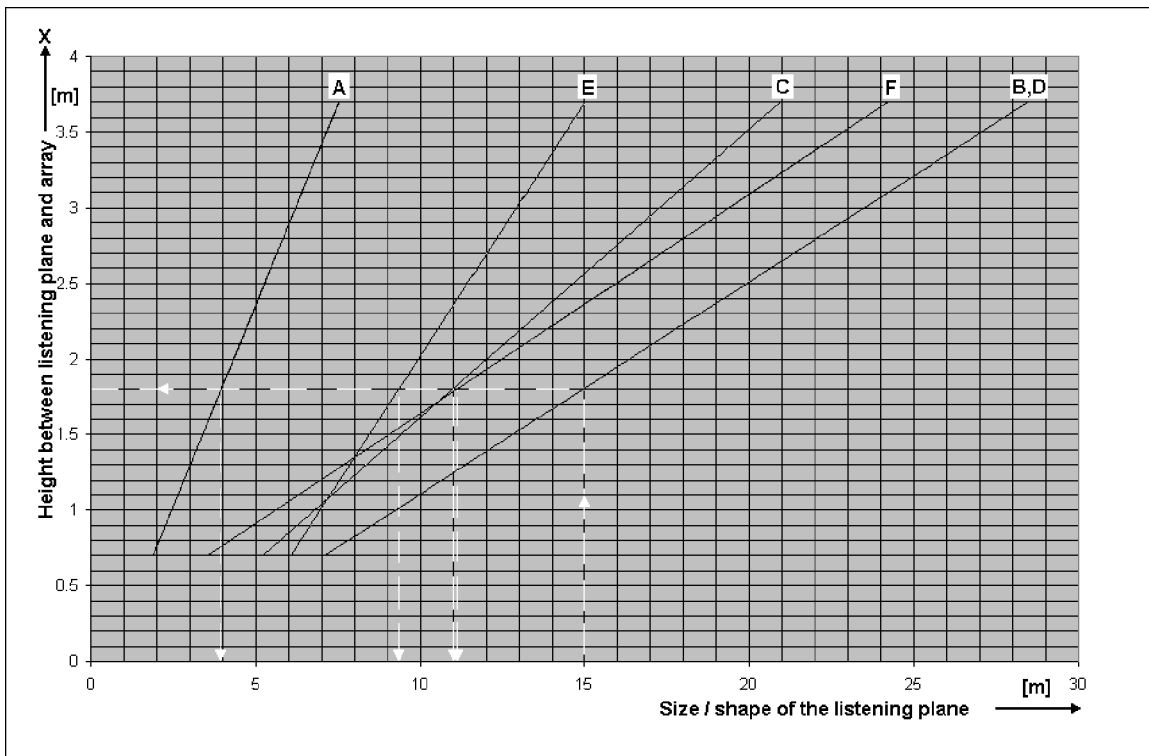
F-Linie: Seitenlänge der Hörebene für 4 kHz

C-Linie: Länge der Hörebene

E-Linie: Halbe Breite der Hörebene für 4 kHz

A-Linie: Mindestentfernung zur Hörebene



Abbildung 1: Abstrahlung der Lautsprechereinheit und Hörebene in Seitenansicht



Abbildung 2: 1 kHz-Oktavenform der Lautsprechereinheit

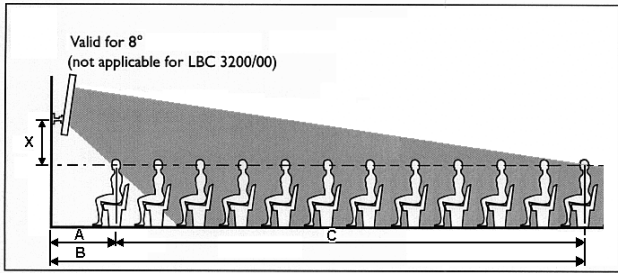

Abbildung 3: 4 kHz-Oktavenform der Lautsprechereinheit

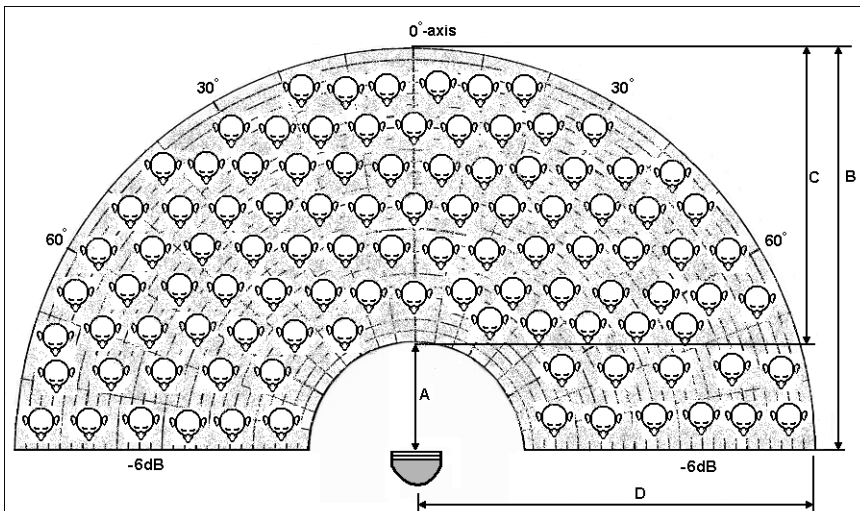

Abbildung 4: Ausrichten der 0°-Achse der Lautsprechereinheit auf die maximale Position

Hörbereich und entsprechende Montagehöhe für XLA3210/00

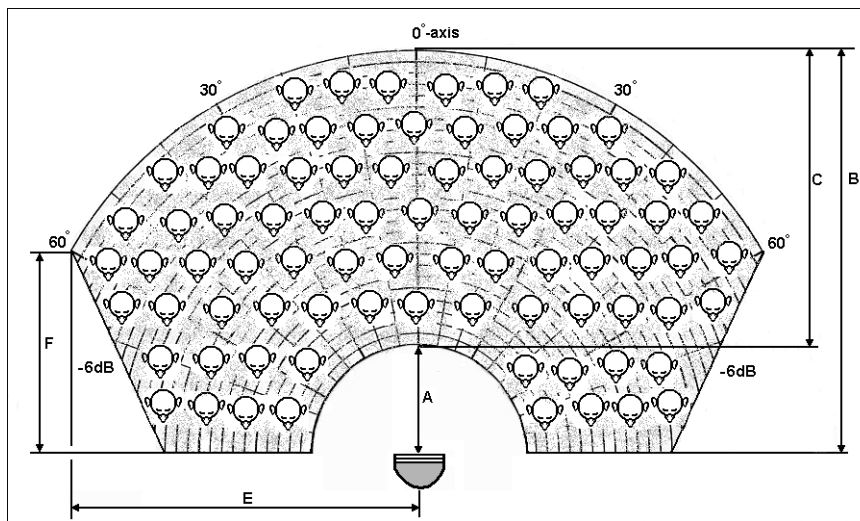
So verwenden Sie diese Montagemethode:

1. Bestimmen Sie die Abmessungen des gewünschten Hörbereichs (eine horizontale Ebene auf Ohrenhöhe der Zuhörer – siehe gestrichelte Linie in Abbildung 1).
2. Messen Sie die maximale Entfernung von der Lautsprechereinheit zum letzten Zuhörer im Hörbereich (d. h. „B“ in den Abbildungen 1, 2 und 3).
3. Gehen Sie in Diagramm 1 von der maximalen Entfernung auf der horizontalen Achse nach oben. Gehen Sie vom vertikalen Schnittpunkt mit der diagonalen B-Linie horizontal zur vertikalen Achse. Der X-Wert (Höhe der Montagehalterung der Lautsprechereinheit über der Hörebene, „X“ in Abbildung 1) steht auf dieser Achse. Die horizontalen Schnittpunkte mit anderen diagonalen Linien geben Informationen zu den Abmessungen des Hörbereichs an. Diese Zahlen beziehen sich auf die Abbildungen 2 und 3 (siehe auch das Beispiel unten).
4. Abbildung 2 zeigt die 1 kHz-Oktavenform, die von der Lautsprechereinheit abgestrahlt wird, und Abbildung 3 zeigt die Abstrahlung der 4 kHz-Oktavenform. Der Hörbereich mit der optimalen Akustikleistung liegt in diesen Formen. Stellen Sie sicher, dass die 4 kHz-Form mit den mithilfe von Diagramm 1 ermittelten Abmessungen den gewünschten Hörbereich ausreichend abdeckt.
5. Wenn der gewünschte Hörbereich von der 4 kHz-Form abgedeckt wird, zeigt der X-Wert auf der vertikalen Achse, wie hoch die Lautsprechereinheit über der Hörebene montiert werden muss. Beachten Sie dabei, dass die Lautsprechereinheit in der gewählten Höhe in einem Winkel von 8° montiert werden muss.

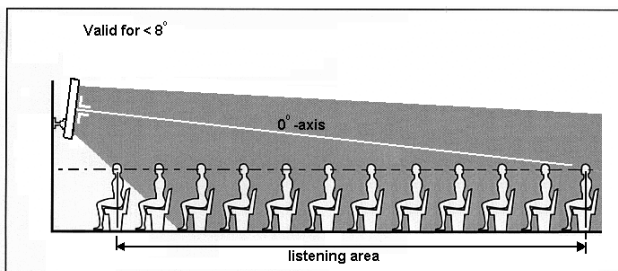
Nun können Sie die Lautsprechereinheit so montieren, dass sich eine optimale Akustikleistung ergibt.

Diagrammbeispiel:

Die maximale Entfernung von der Lautsprechereinheit zum letzten Zuhörer beträgt 15 m. Wenn Sie vom 15 m-Punkt auf der horizontalen Achse von Diagramm 1 zur diagonalen B-Linie nach oben und anschließend seitlich zur vertikalen Achse gehen, geben die Schnittpunkte mit den anderen diagonalen Linien die Abmessungen der Hörebene an. In diesem Beispiel:

F-Linie (Seitenlänge der Hörebene für 4 kHz) = 12,2 m

C-Linie (Länge der Hörebene) = 11 m

E-Linie (halbe Breite der Hörebene für 4 kHz) = 8,6 m

A-Linie (Mindestentfernung zur Hörebene) = 3,9 m

Auf der vertikalen Achse beträgt der X-Wert (die Höhe zwischen der Hörebene und der Montageklammer der Lautsprechereinheit) 1,8 m.

Fragen und Antworten zur Installation:

- **Der gewünschte Hörbereich ist zu groß und passt nicht in die 4 kHz-Form.**
Probieren Sie eine andere Montagehöhe für die Lautsprechereinheit aus, oder verwenden Sie mehr Lautsprechereinheiten, um einen größeren Hörbereich zu erhalten.
- **Warum muss ein 8°-Winkel für die Lautsprechereinheit verwendet werden?**
Die Abstrahlungsformen in den Abbildungen 2 und 3 gelten nur dann für die Abmessungen in Diagramm 1, wenn die Lautsprechereinheit in einem Winkel von 8° montiert ist. Nur in diesem Fall erhalten Sie einen konstanten Schalldruckpegel und Frequenzgang (Constant Directivity) im Hörbereich.
- **Kann ich die Lautsprechereinheit in einem anderen Winkel anbringen?**
Sie können die Lautsprechereinheiten auch in einem anderen Winkel anbringen, erhalten dann jedoch nicht die optimale Akustikleistung. _Beispielsweise treten im Hörbereich größere Variationen im Schalldruckpegel auf. Die Werte in Diagramm 1 gelten nicht für andere Winkel. Winkel über 8° werden grundsätzlich nicht empfohlen.
- **Die Lautsprechereinheit kann nicht in der gewünschten Höhe montiert werden.**
Wenn die gewünschte Höhe nicht erreicht werden kann, z. B. weil die Decke zu niedrig ist, wählen Sie einen Winkel unter 8°. Richten Sie die 0°-Achse der Lautsprechereinheit auf die gewünschte maximale Position (siehe Abbildung 4). Beachten Sie, dass in diesem Fall die Tabelle in Diagramm 1 und die Formen in den Abbildungen 2 und 3 nicht gelten. Überprüfen Sie im Hörbereich, ob ein Redner deutlich genug zu verstehen ist.

Hintergrundinformationen:

- Die Formen wurden in einem schalltoten Raum definiert. In einem schalltoten Raum erhalten Sie mit diesen Formen maximal 6 dB Schalldruckvariation und eine bedeutend geringere Variation im wahrgenommenen Frequenzgang. In Bereichen mit normalem oder hohem Nachhall treten geringere Variationen des Schalldruckpegels auf, und die Formen sind größer. Der wahrgenommene Frequenzgang in dieser Form ist dann fast konstant.
- Wenn Sie sich aus dem Hörbereich herausbewegen (über die maximale Entfernung von der Lautsprechereinheit hinaus), verringert sich lediglich der Schalldruckpegel. Variationen der Tonhöhe treten fast nicht auf. Wie stark der Schalldruckpegel abnimmt, hängt stark vom Raumhall ab.
- Wenn Sie sich zu nahe an den Lautsprechereinheiten befinden (weniger als die Mindestentfernung von der Lautsprechereinheit), werden hohe Töne sehr schnell beeinträchtigt.
- Abhängig von Raumhall und Schallschatten (Personen oder Objekten vor einem Zuhörer, die die direkte

Schallquelle blockieren) können die am weitesten entfernten sitzenden Zuhörer einen Redner möglicherweise nur schwer verstehen. In diesem Fall ist es besser, mehrere Lautsprechereinheiten zu verwenden und den Hörbereich so aufzuteilen.

- Die Seitenlinien der Formen in Abbildung 2 und 3 sind die -6 dB-Punkte zum Schalldruckpegel auf der 0°-Achse.
- Für eine optimale Verständlichkeit des Redners müssen Sie einen Hörbereich definieren, in dem die 4 kHz-Oktavenform den gesamten Bereich abdeckt. Die Ränder des Hörbereichs in einer gegebenen Situation können nur durch einen praktischen Test in dem Raum, in dem die Lautsprechereinheit installiert wird, genau bestimmt werden. Diese Aufgabe muss von einem erfahrenen Zuhörer mit einem gut ausgebildeten Gehör ausgeführt werden. Spielen Sie dazu rosa Rauschen über die Lautsprechereinheit ein. Für diesen Test sollten Sie die tieferen Töne reduzieren, da sie nicht zur Sprachverständlichkeit beitragen. Bewegen Sie sich im Hörbereich, und hören Sie sich die hohen Töne an. Die Ränder des Hörbereichs befinden sich dort, wo die hohen Töne sehr schnell abnehmen.



Diagramm 1: Beziehung zwischen Hörbereich und Montagehöhe der Lautsprechereinheit

Bedeutung der Linien

B-Linie: Maximale Entfernung von der Lautsprechereinheit zum letzten Zuhörer

D-Linie: Halbe Breite der Hörebene für 1 kHz

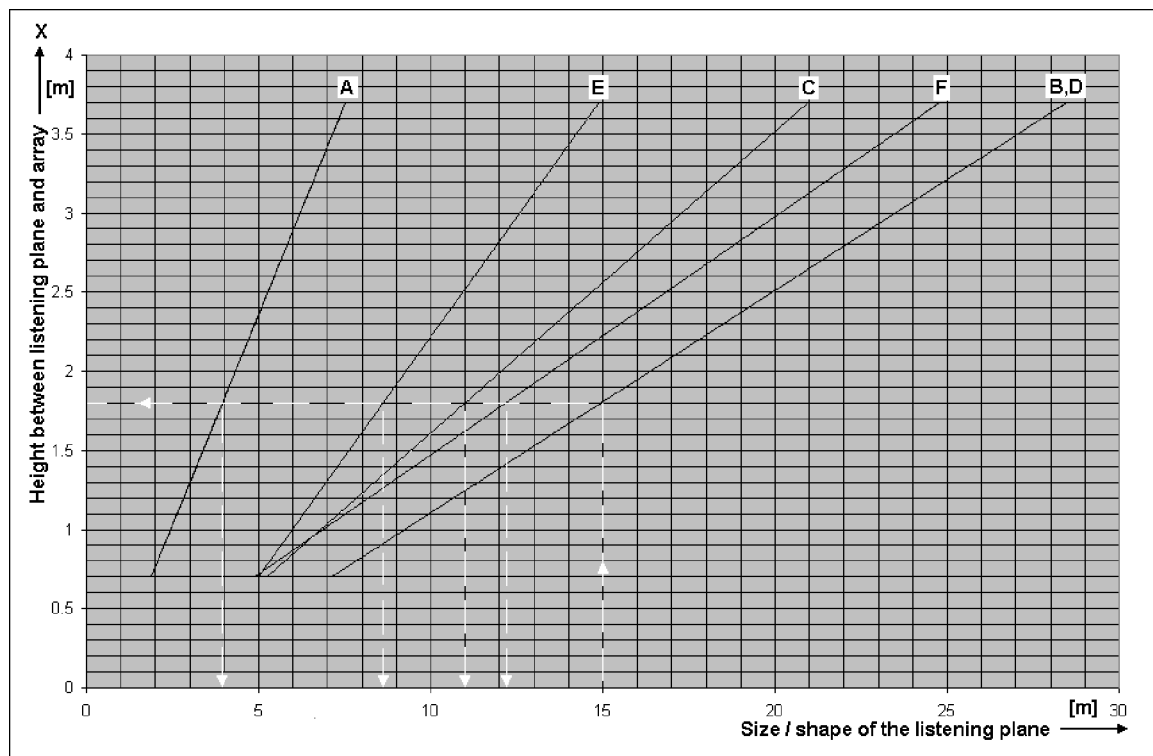
F-Linie: Seitenlänge der Hörebene für 4 kHz

C-Linie: Länge der Hörebene

E-Linie: Halbe Breite der Hörebene für 4 kHz

A-Linie: Mindestentfernung zur Hörebene



Abbildung 1: Abstrahlung der Lautsprechereinheit und Hörebene in Seitenansicht



Abbildung 2: 1 kHz-Oktavenform der Lautsprechereinheit

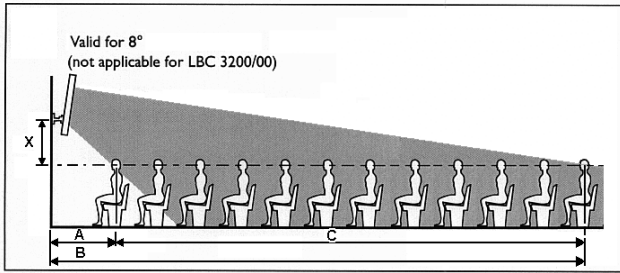

Abbildung 3: 4 kHz-Oktavenform der Lautsprechereinheit

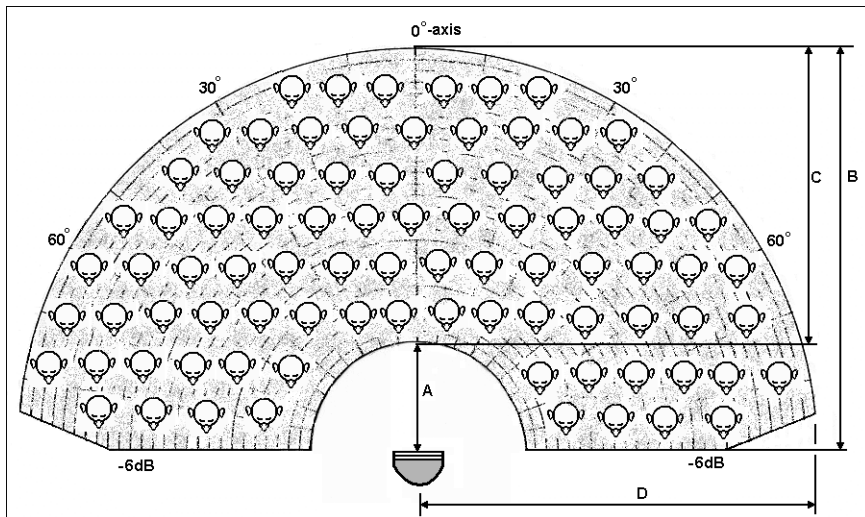

Abbildung 4: Ausrichten der 0°-Achse der Lautsprechereinheit auf die maximale Position

TECHNISCHE LEISTUNGSDATEN**LBC 3200/00**

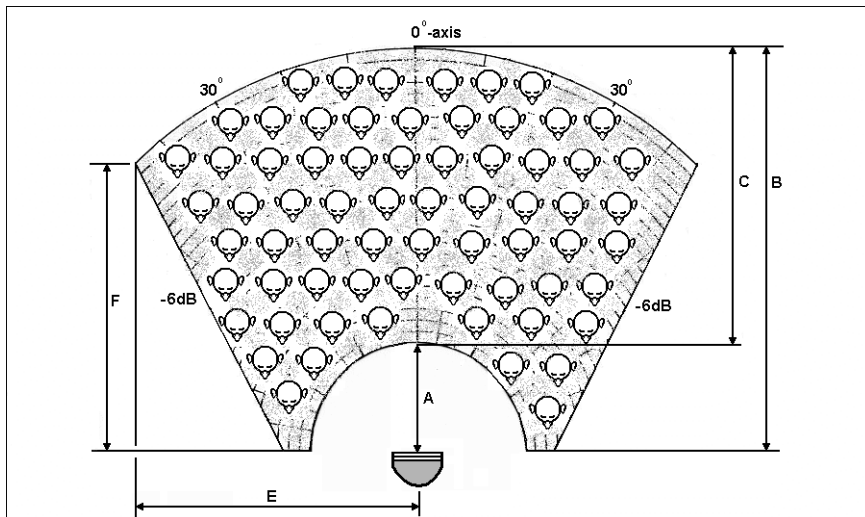
Maximale Leistung	45 W
Nennleistung	30 W (30-15-7,5 W)
Schalldruckpegel bei	
30 W/1 W (bei 1 kHz, 1 m)	106 dB/91 dB (SPL)
Effektiver Frequenzbereich (-10 dB)	190 Hz bis 18 kHz
Öffnungswinkel	
(bei 1 kHz/4 kHz, -6 dB)	
Horizontal	220° /130°
Vertikal	70° /18°
Nenneingangsspannung	100 V
Nennimpedanz	333 Ohm
Umgebungstemperaturbereich	-25°C bis +55°C
Sicherheit	nach EN 60065
Anschluss	Schraub-Klemmleiste
Abmessungen (H x B x T)	600 x 80 x 90 mm
Farbe	Silber
Gewicht	3 kg

**LBC 3200/00**

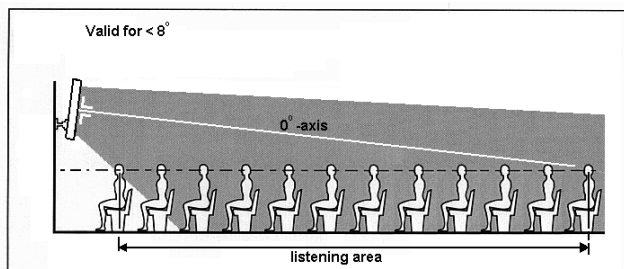
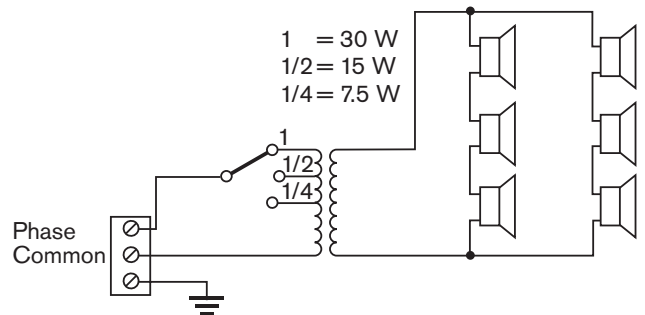
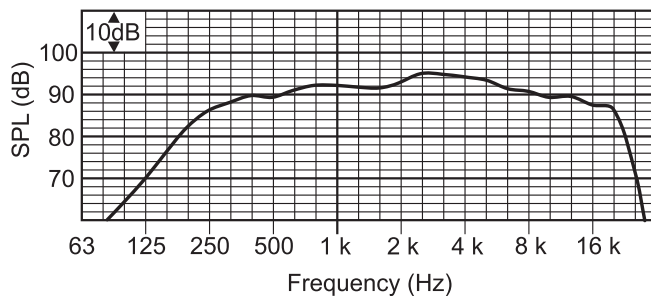
Oktavband (Hz)	250	500	1 k	2 k	4 k	8 k
Schalldruckpegel 1 W,1 m	87	89	91	93	93	89
Schalldruckpegel max.	102	104	106	108	108	104
Q-Faktor	1.3	2.2	4.5	11,6	25,7	58,9
Hor. Winkel (Grad)	360	360	220	190	130	100
Vert. Winkel (Grad)	360	120	70	32	18	10

Horizontal

Vertical

LBC 3200/00
250Hz horizontal

LBC 3200/00
250Hz vertical

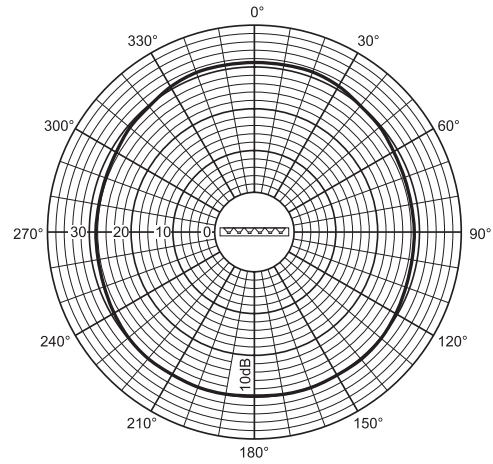
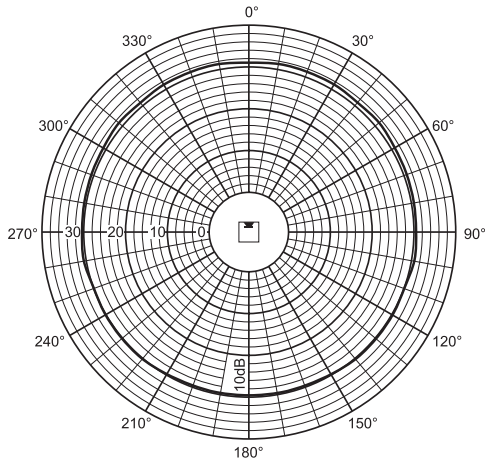

LBC 3200/00
500Hz horizontal

LBC 3200/00
500Hz vertical

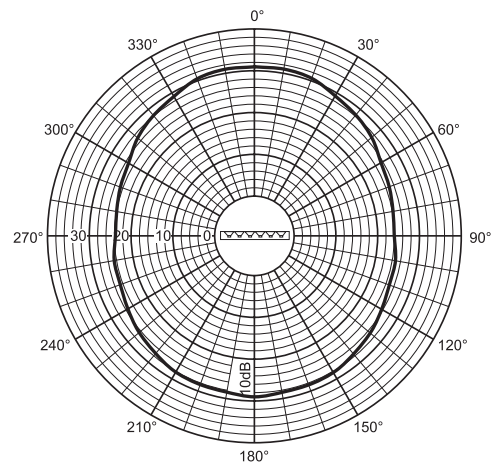
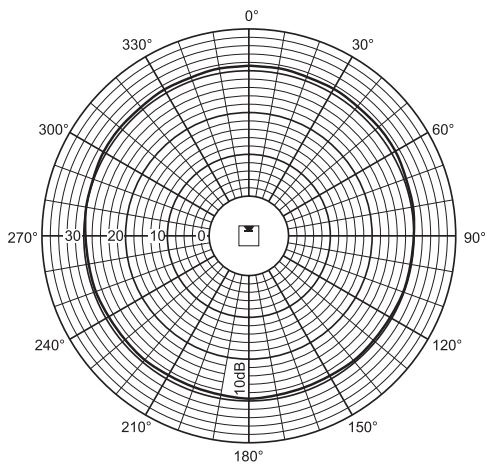

LBC 3200/00
1kHz horizontal

LBC 3200/00
1kHz vertical

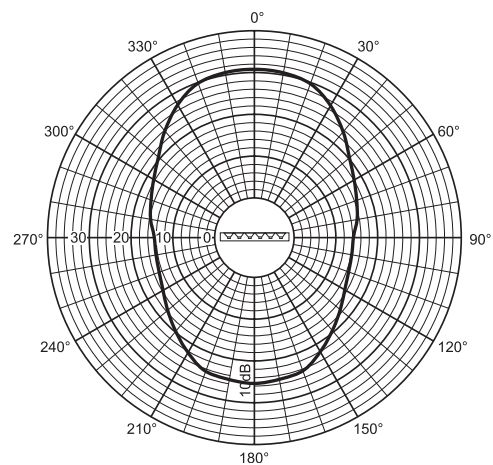
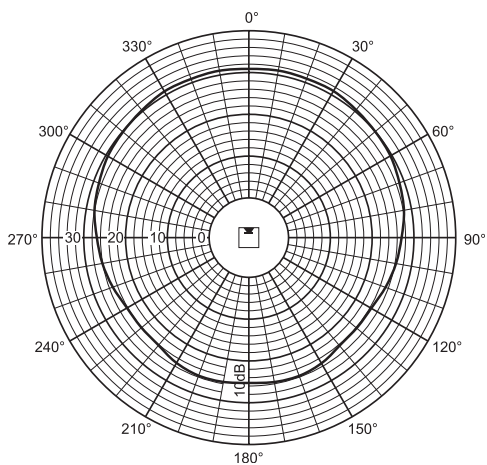

Horizontal

Vertical

LBC 3200/00
2kHz horizontal

LBC 3200/00
2kHz vertical

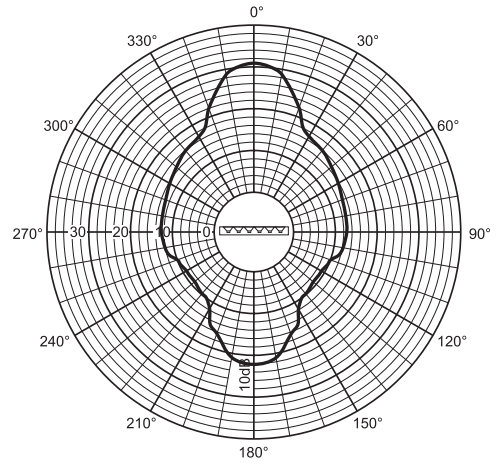
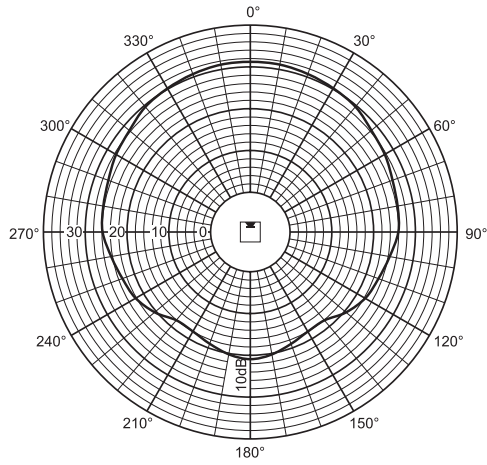

LBC 3200/00
4kHz horizontal

LBC 3200/00
4kHz vertical

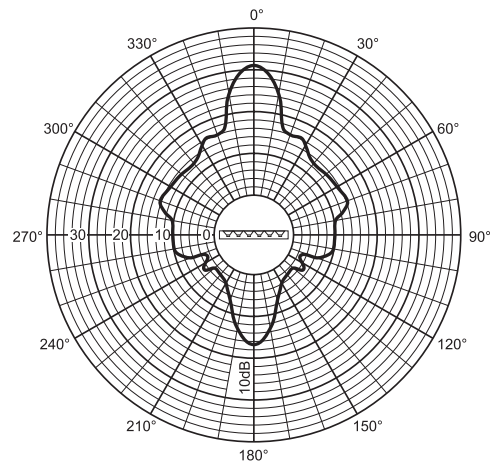
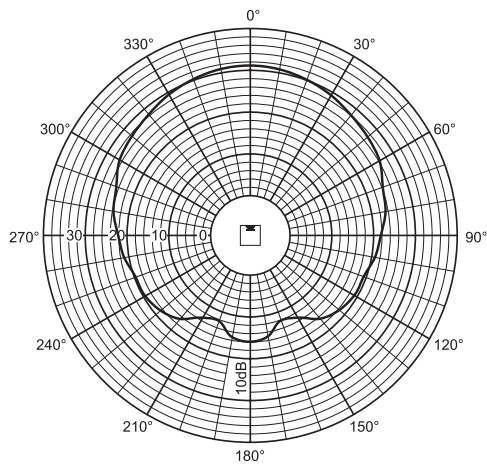

LBC 3200/00
8kHz horizontal

LBC 3200/00
8kHz vertical

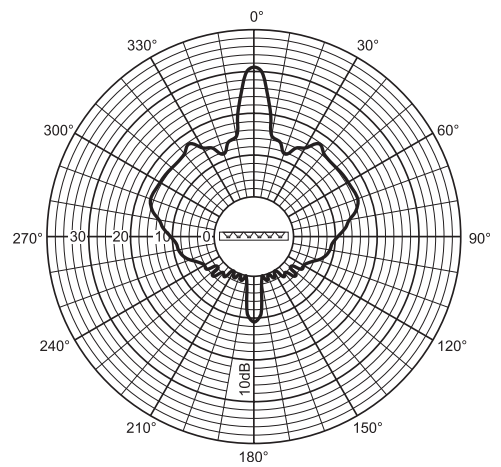
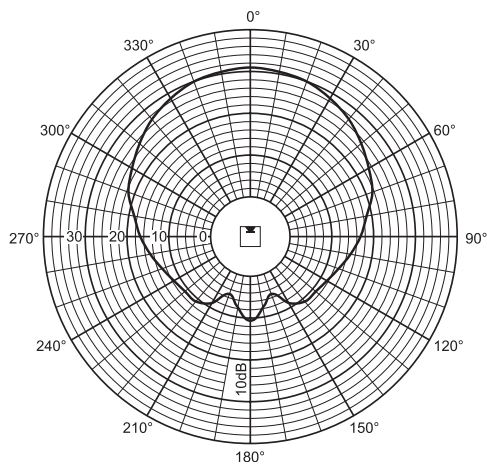

TECHNISCHE LEISTUNGSDATEN

LBC 3201/00

Maximale Leistung	90 W
Nennleistung	60 W (60-30-15 W)
Schalldruckpegel bei	
60 W/1 W (bei 1 kHz, 1 m)	110 dB/92 dB (SPL)
Effektiver Frequenzbereich (-10 dB)	190 Hz bis 18 kHz
Öffnungswinkel	
(bei 1 kHz/4 kHz, -6 dB)	
Horizontal	210°/132°
Vertikal	50°/22°
Nenneingangsspannung	100 V
Nennimpedanz	167 Ohm
Umgebungstemperaturbereich	-25°C bis +55°C
Sicherheit	nach EN 60065
Anschluss	Schraub-Klemmleiste
Abmessungen (H x B x T)	1200 x 80 x 90 mm
Farbe	Silber
Gewicht	6,4 kg

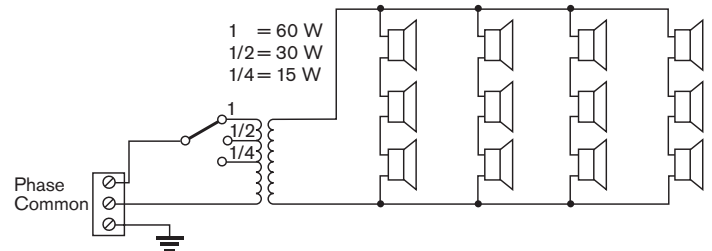
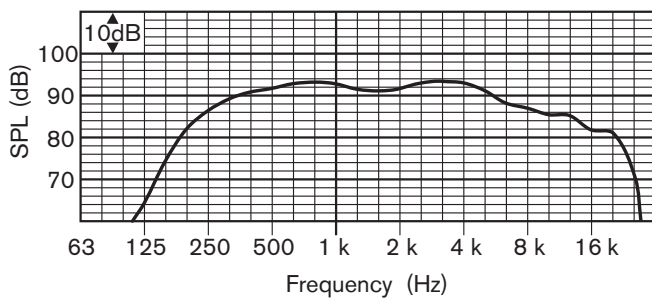

LBC 3201/00

Oktavband (Hz)	250	500	1 k	2 k	4 k	8 k
Schalldruckpegel 1 W, 1 m	88	92	92	91	91	86
Schalldruckpegel max.	106	110	110	109	109	104
Q-Faktor	2,2	3,2	6,5	12,6	23,4	53,3
Hor. Winkel (Grad)	360	360	210	192	132	100
Vert. Winkel (Grad)	107	67	50	33	22	12

Horizontal

Vertical

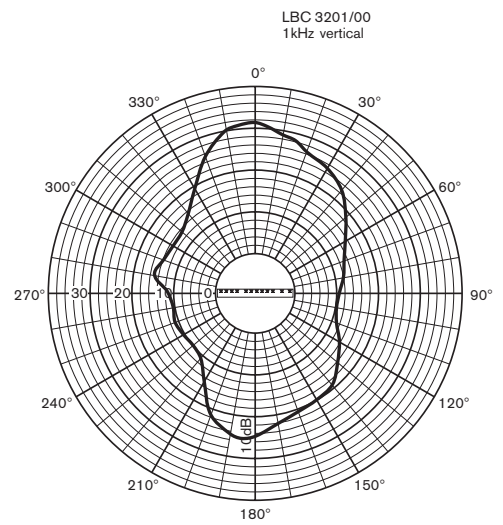
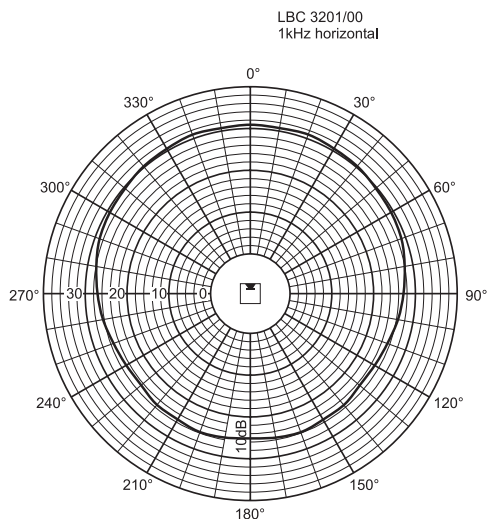
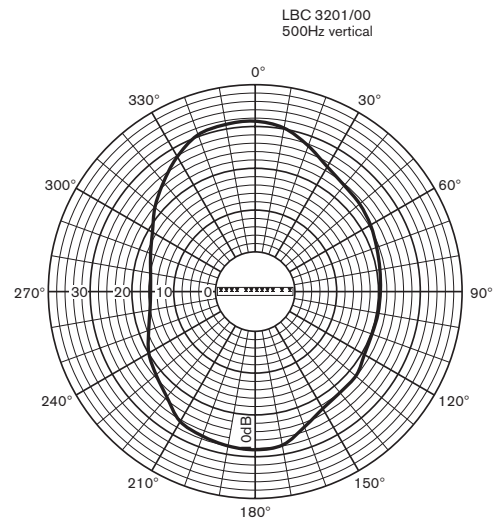
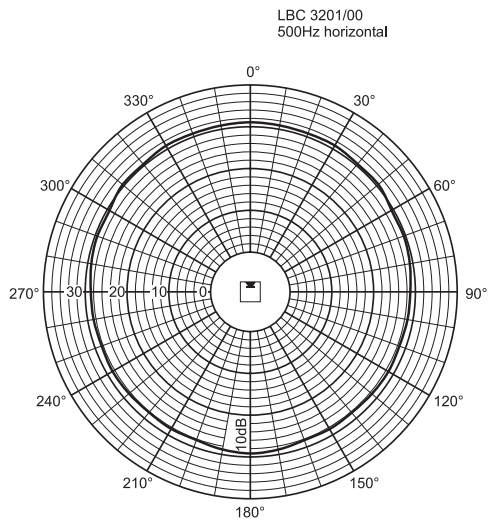
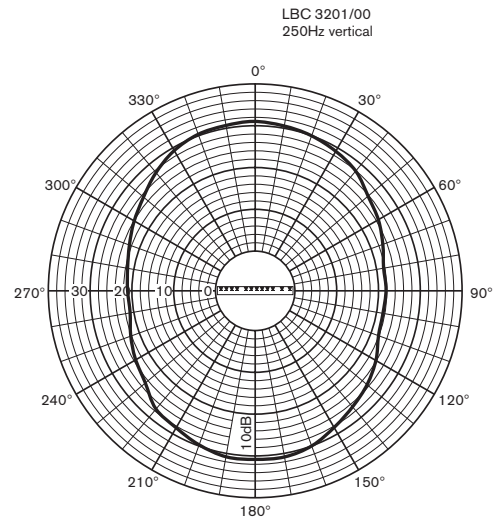
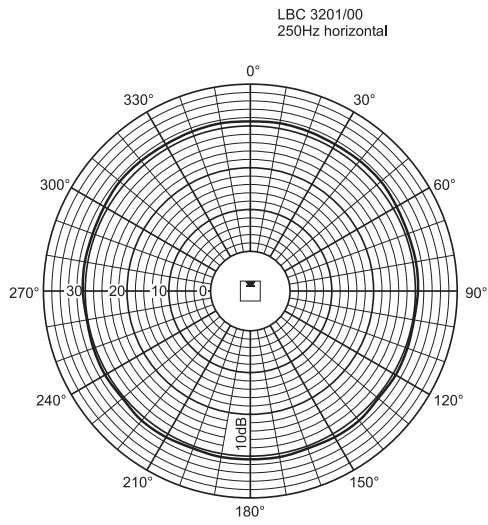

Horizontal

Vertical

LBC 3201/00
2kHz horizontal

LBC 3201/00
2kHz vertical

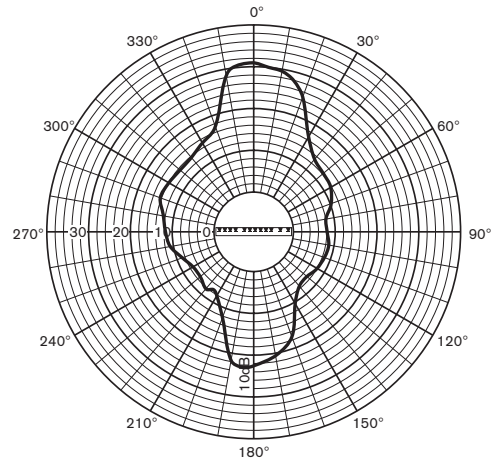
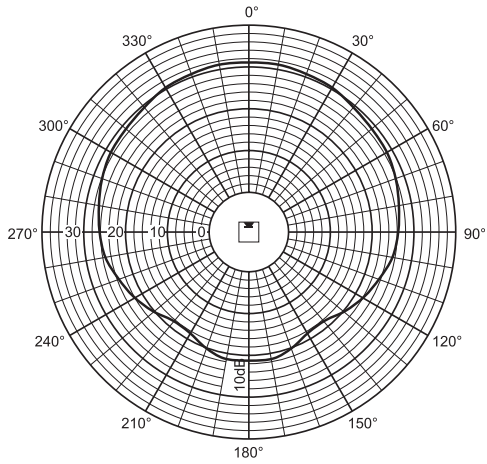

LBC 3201/00
4kHz horizontal

LBC 3201/00
4kHz vertical

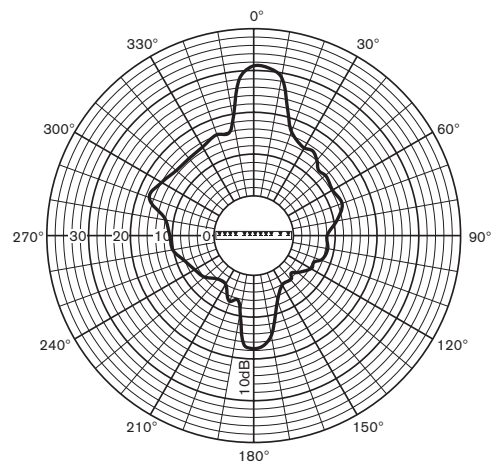
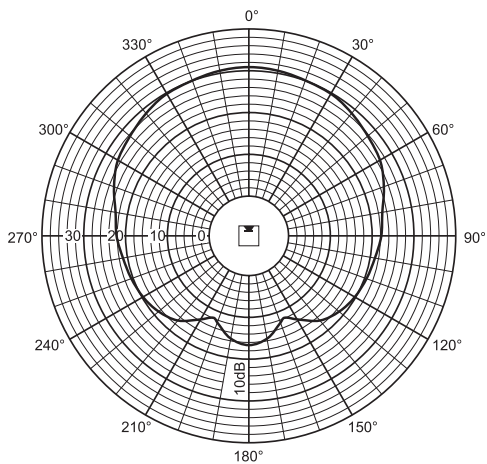

LBC 3201/00
8kHz horizontal

LBC 3201/00
8kHz vertical

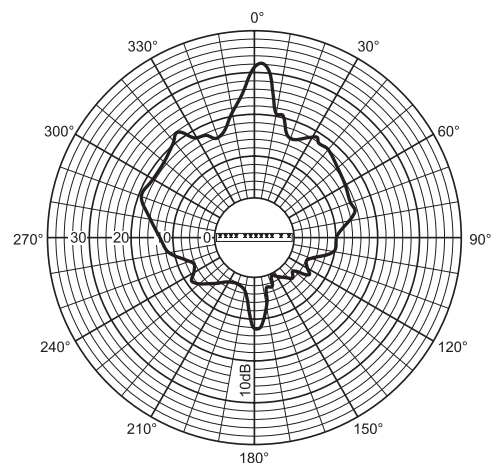
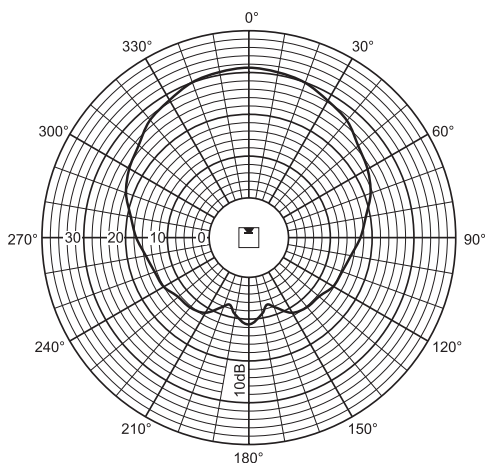

TECHNISCHE LEISTUNGSDATEN**LBC 3210/00**

Maximale Leistung	90 W
Nennleistung	60 W (60-30-15 W)
Schalldruckpegel	
bei 60 W/1 W (bei 1 kHz, 1 m)	115 dB/97 dB (SPL)
Effektiver Frequenzbereich (-10 dB)	190 Hz bis 20 kHz
Öffnungswinkel	
(bei 1 kHz/4 kHz, -6 dB)	
Horizontal	170°/90°
Vertikal	55°/18°
Nenneingangsspannung	100 V
Nennimpedanz	167 Ohm
Umgebungstemperaturbereich	-25°C bis +55°C
Sicherheit	nach EN 60065
Wasser-/Staubschutz	IP 66 nach IEC 60529
Anschluss	Schraub-Klemmleiste
Abmessungen (H x B x T)	1200 x 160 x 90 mm
Farbe	Silber
Gewicht	9 kg

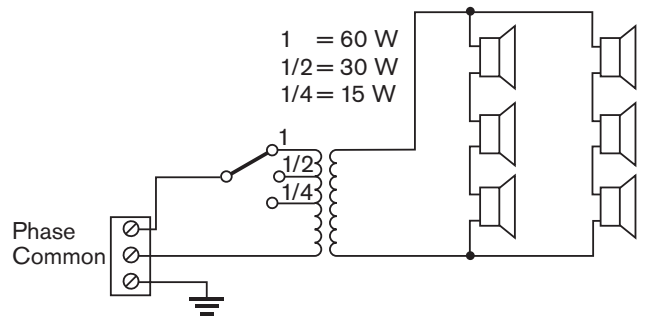
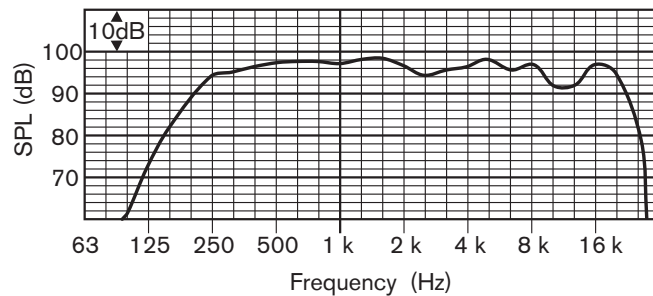
**LBC 3210/00**

Oktavband (Hz)	250	500	1 k	2 k	4 k	8 k
Schalldruckpegel 1 W, 1 m	94	97	97	95	96	93
Schalldruckpegel max.	112	115	115	113	114	111
Q-Faktor	2,2	2,7	6,3	10,8	22,6	32,3
Hor. Winkel (Grad)	360	180	170	160	90	60
Vert. Winkel (Grad)	100	60	55	34	18	10

Horizontal

Vertical

LBC 3210/00
250Hz horizontal

LBC 3210/00
250Hz vertical

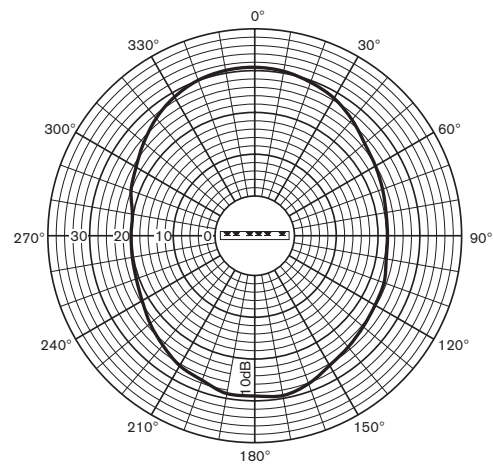
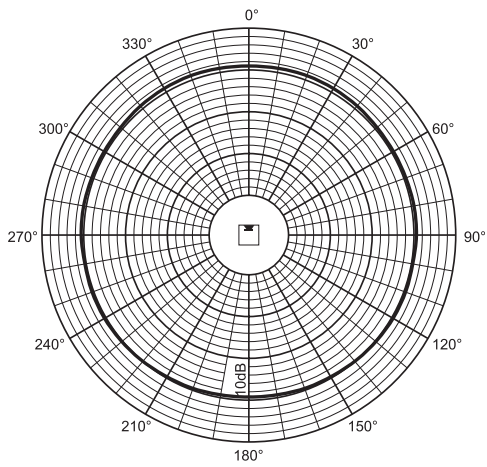

LBC 3210/00
500Hz horizontal

LBC 3210/00
500Hz vertical

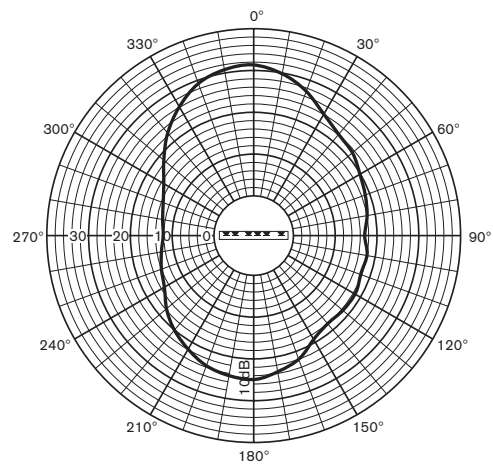
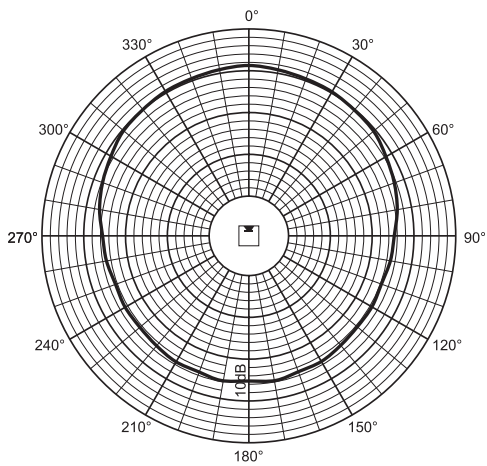

LBC 3210/00
1kHz horizontal

LBC 3210/00
1kHz vertical

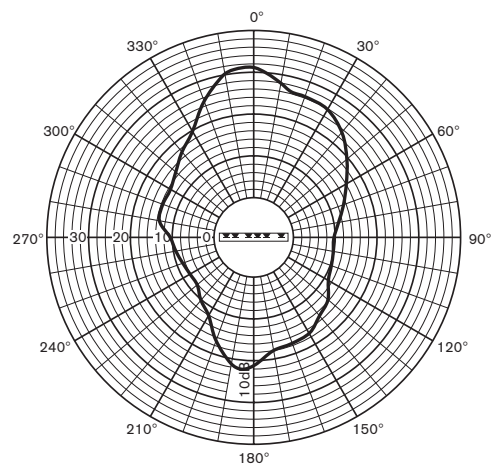
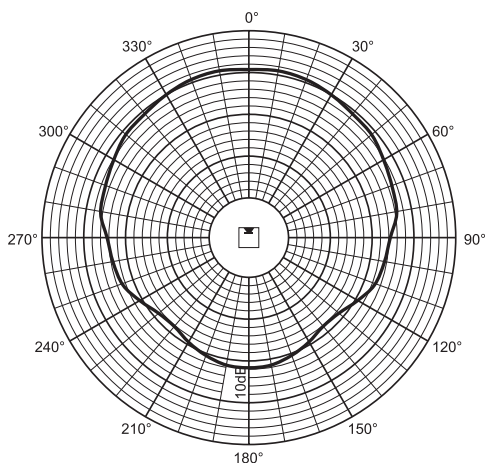

Horizontal

Vertical

LBC 3210/00
2kHz horizontal

LBC 3210/00
2kHz vertical

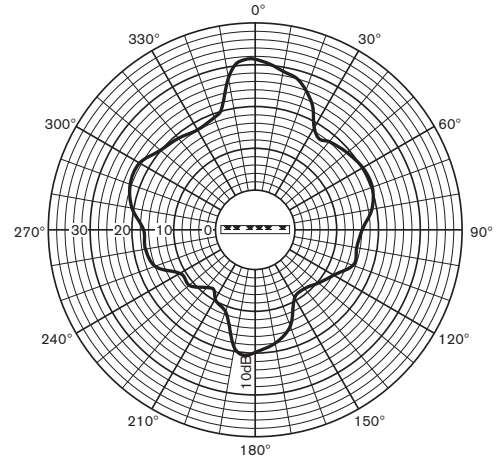
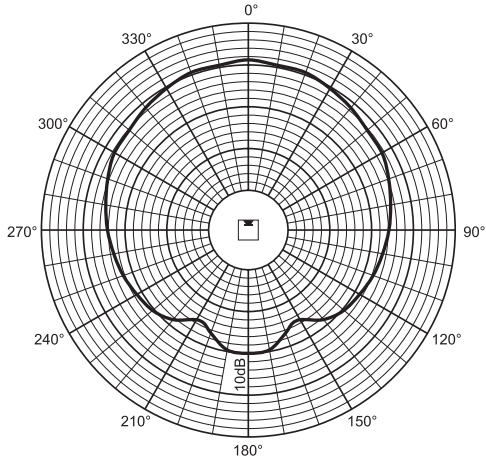

LBC 3210/00
4kHz horizontal

LBC 3210/00
4kHz vertical

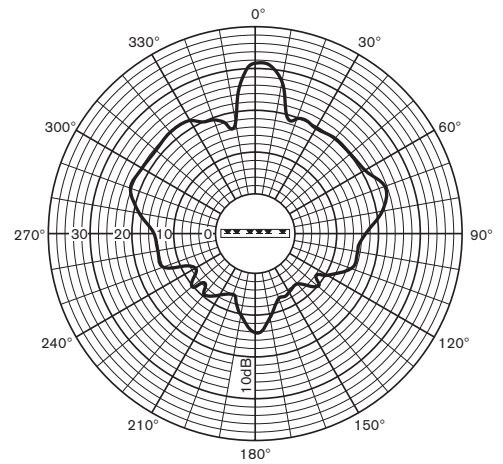
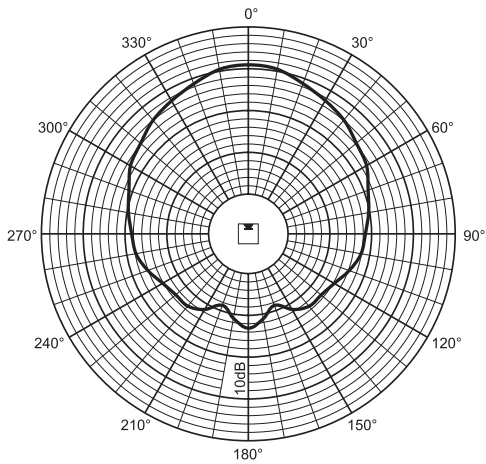

LBC 3210/00
8kHz horizontal

LBC 3210/00
8kHz vertical

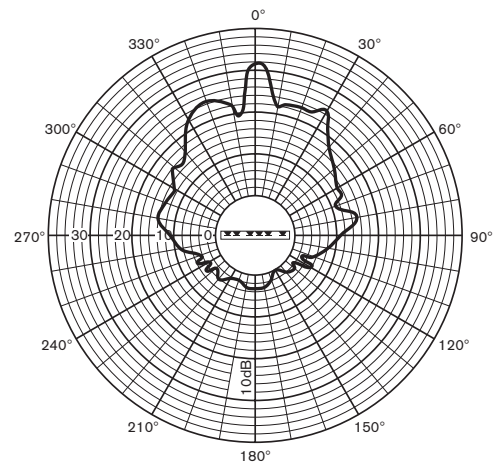
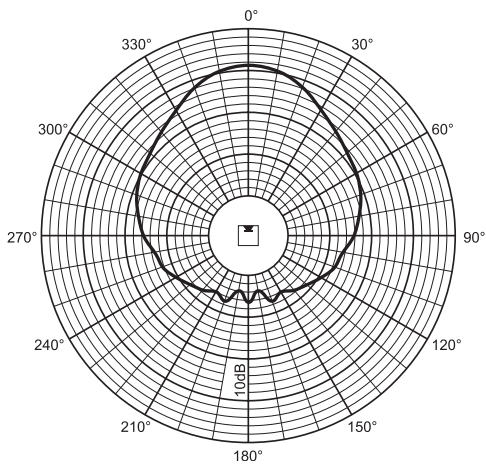

www.boschsecuritysystems.com

BOSCH

Índice	Página
Guía de instalación (fig. 1 - fig. 17)	72
Montaje del tablero de supervisión de línea/altavoz (opcional) (fig. A1 - fig. A5)	74
Montaje de soporte adicional (opcional) (fig. B1 - fig. B5)	74
Montaje del soporte de suelo (opcional) (fig. C1 - fig. C3).....	74
Área de audición y altura de montaje correspondiente de LBC 3200/00	75
Área de audición y altura de montaje correspondiente de LBC 3201/00	77
Área de audición y altura de montaje correspondiente de LBC 3210/00	80
Datos técnicos de LBC 3200/00	83
Datos técnicos de LBC 3201/00.....	86
Datos técnicos de LBC 3210/00.....	89

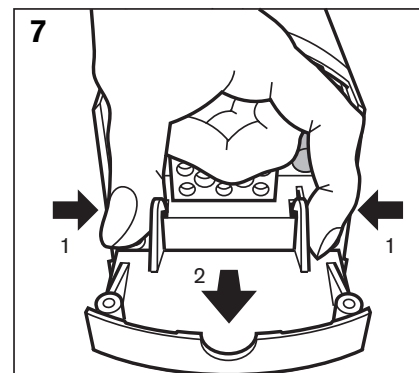
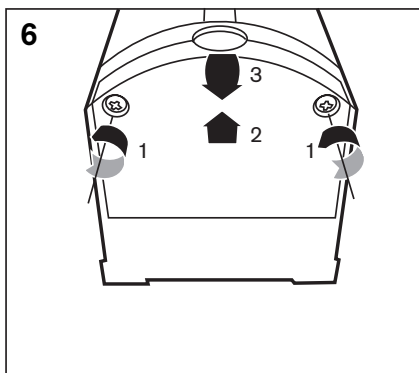
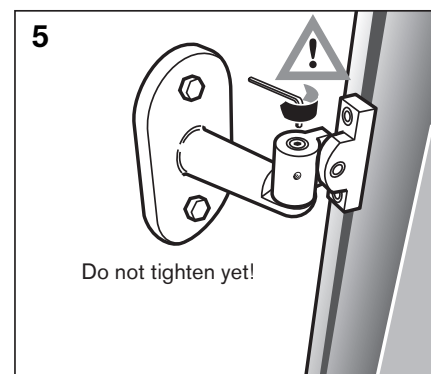
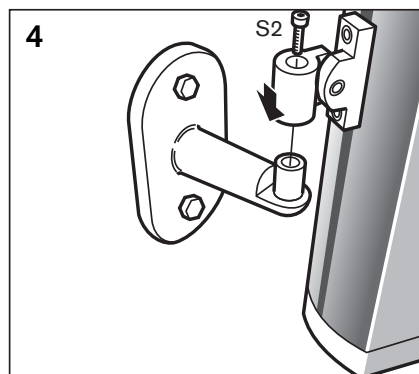
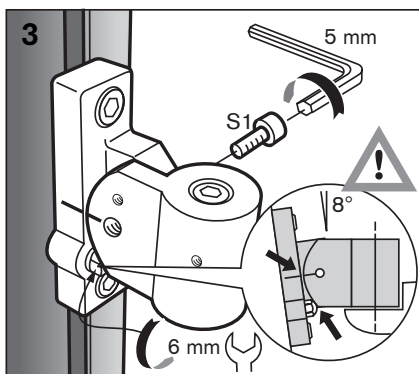
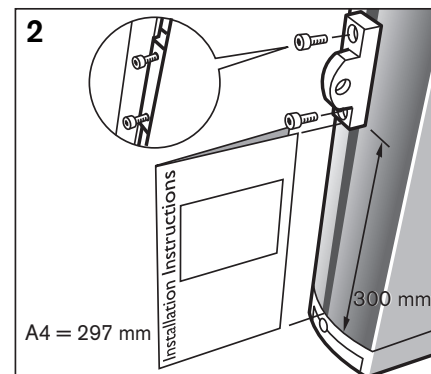
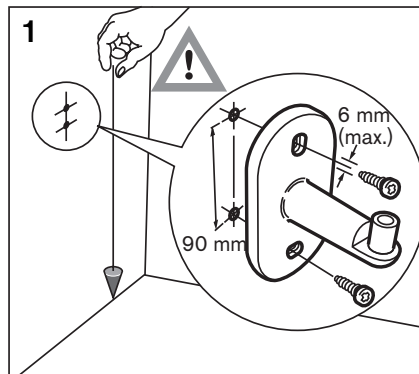
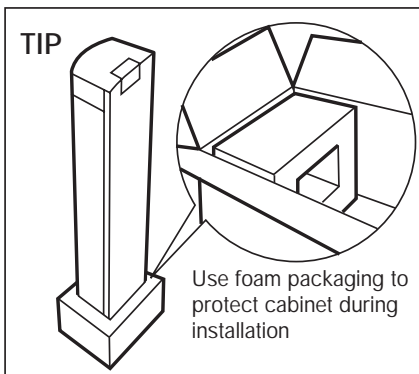
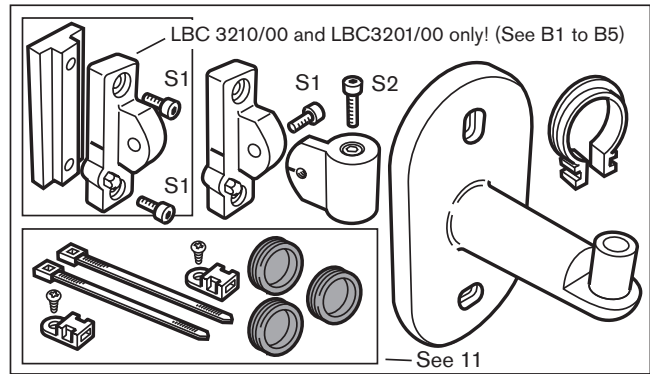
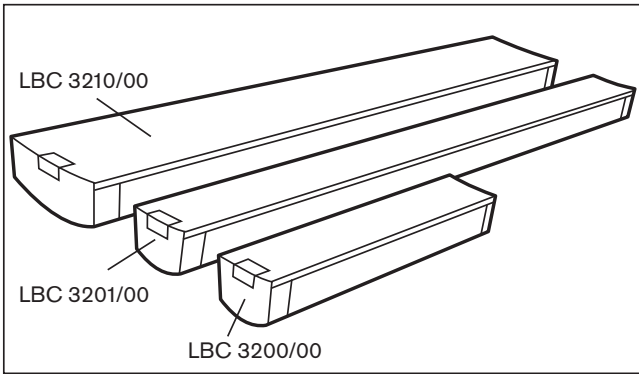

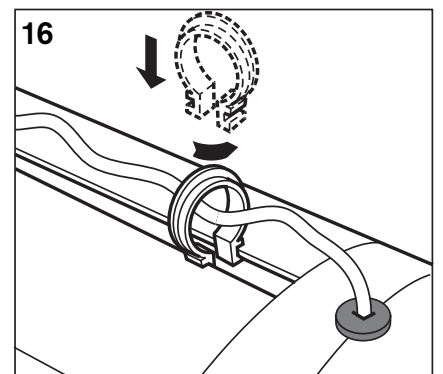
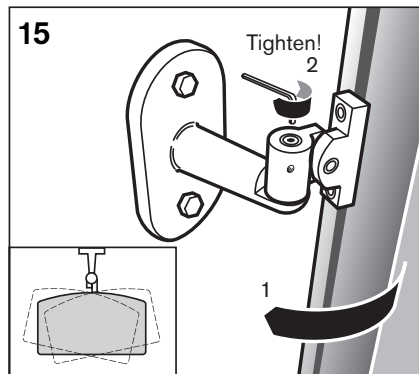
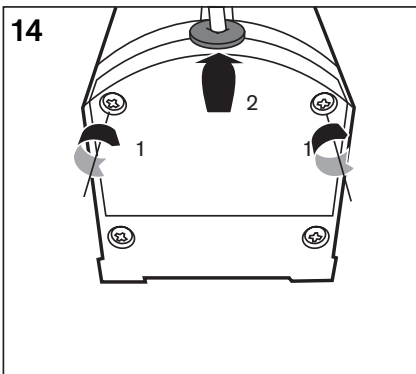
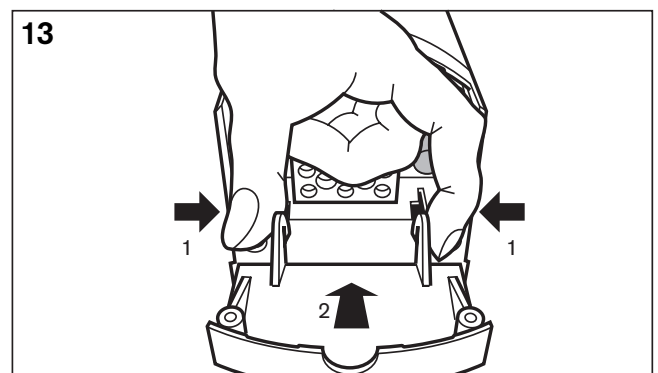
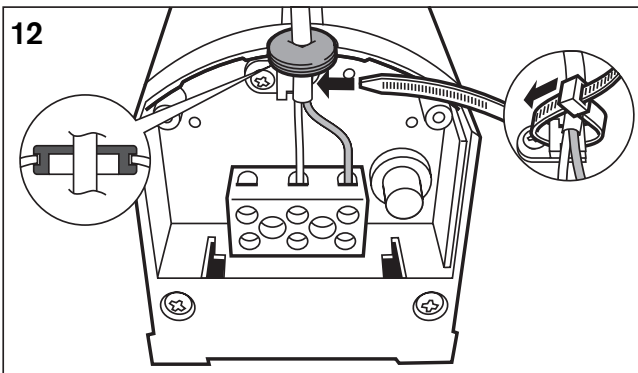
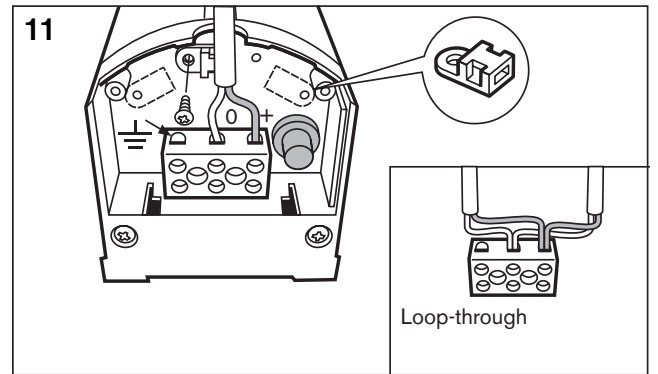
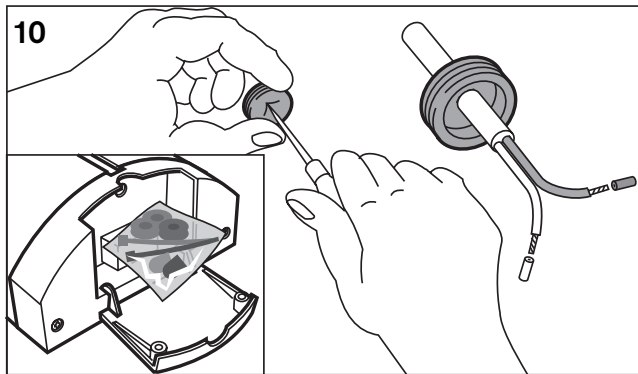
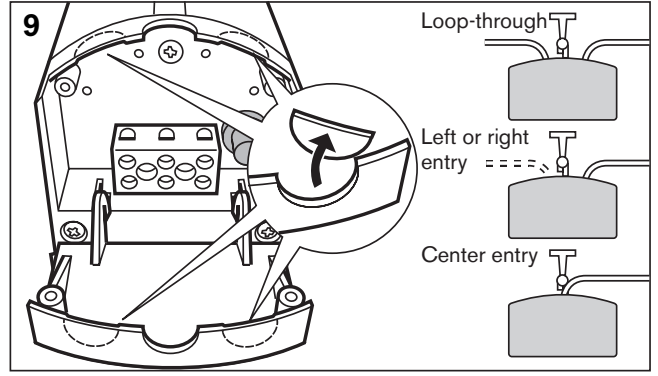
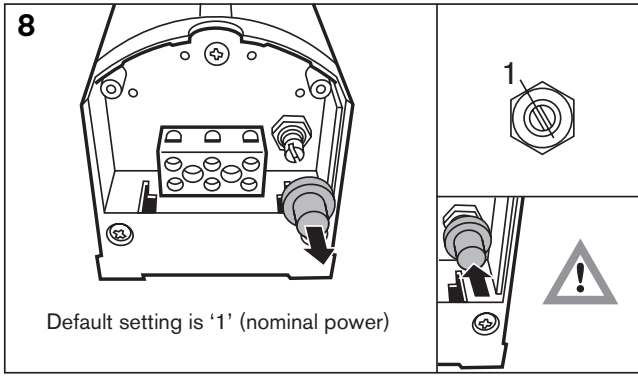

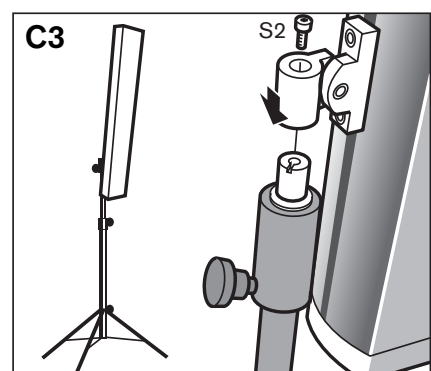
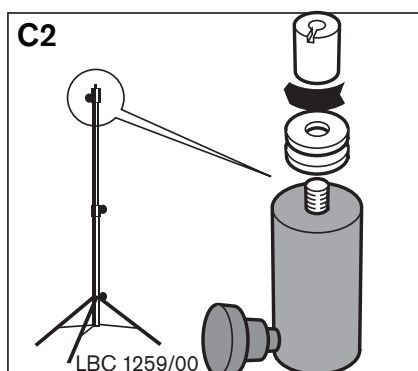
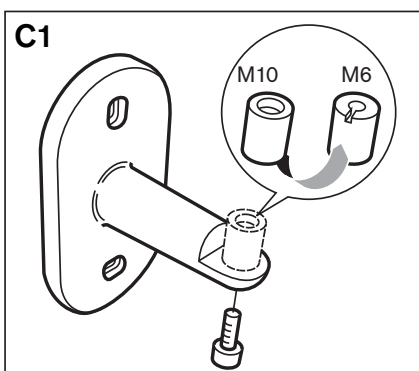
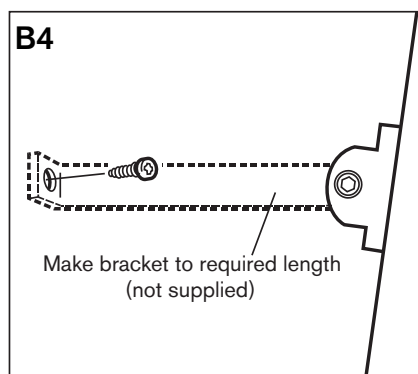
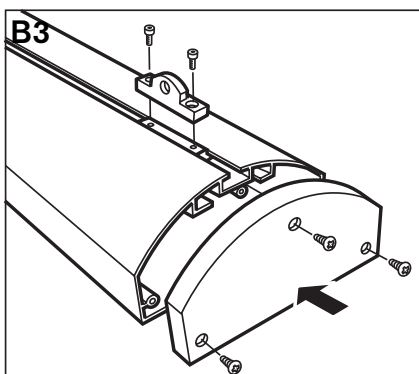
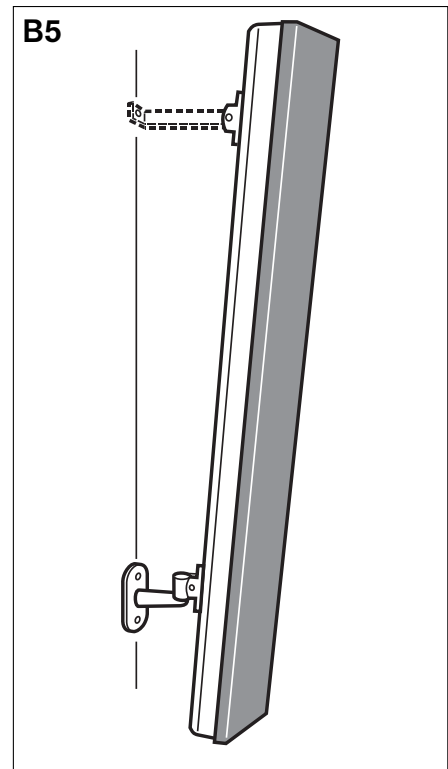
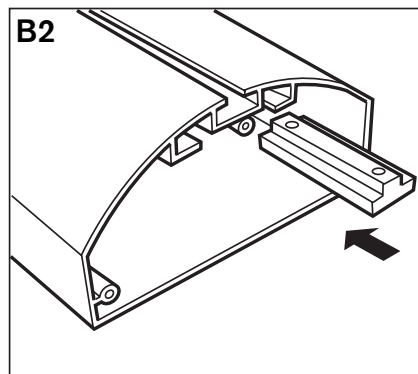
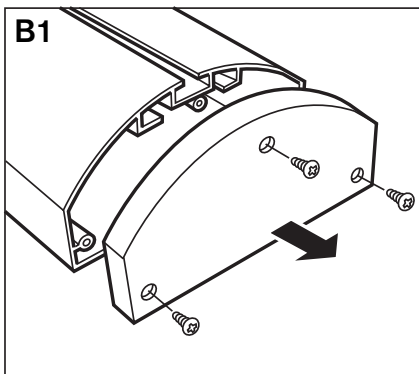
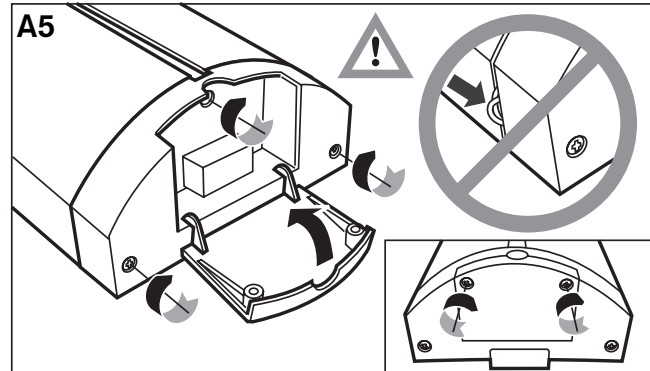
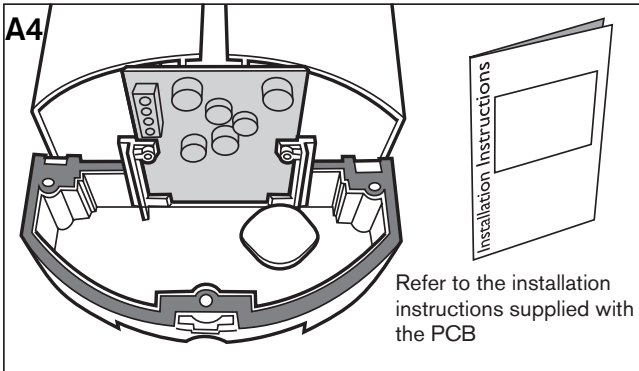
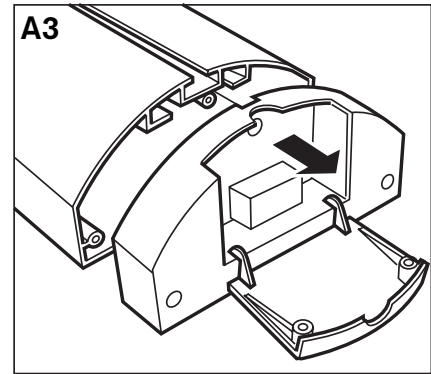
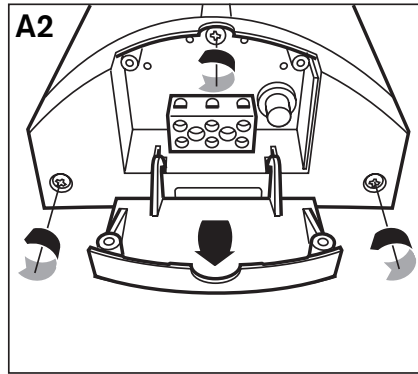
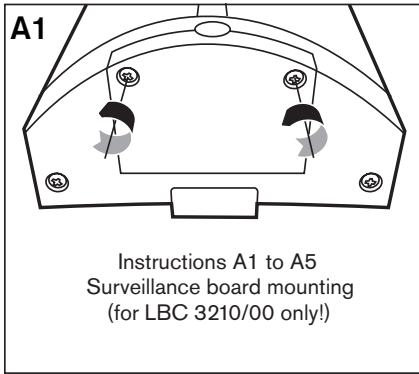

Área de audición y altura de montaje correspondiente de XLA3200/00

Ángulo y altura de montaje de la columna LBC3200:

1. Determine las dimensiones del 'área de escucha' deseada (plano horizontal al nivel de los oídos del oyente; consulte la línea discontinua de la figura 1).
2. Determine el ángulo de montaje de la columna. La columna está diseñada para transmitir el sonido justo por encima de la cabeza de los oyentes. Se recomienda que no sobrepase un ángulo de 6°. Existen dos opciones, cada una de ellas con sus ventajas e inconvenientes específicos.
 - Opción 1: área máxima de audición
Si desea una gran área de audición, se recomienda un ángulo de unos 3° (consulte la figura 1). Observe que al alejarse de la columna, el nivel de presión acústica disminuirá en función de la reverberación de la sala. Para escuchar con claridad los tonos agudos, es necesario que el oyente pueda ver la columna desde su posición.
 - Opción 2: variación reducida del nivel de presión acústica
Si desea una menor variación del nivel de presión acústica, se recomienda un ángulo de 5°. Observe que de este modo se reduce el tamaño del área total de audición en comparación con la opción 1 y que el espacio más cercano a la columna ('A' en la figura 2) no forma parte del área de audición. El diagrama 1 muestra la relación entre 'A' y la altura de montaje de la columna al utilizar un ángulo de instalación de 5°.
3. Una vez seleccionada la opción más apropiada del ángulo de montaje, la altura del altavoz se determina enfocando el eje 00 del mismo hacia la posición deseada, justo por encima de los oídos del oyente más alejado. Esta posición se puede ajustar montando el altavoz en un lugar más alto o más bajo de la pared.

Ya puede montar la columna para un rendimiento acústico óptimo.

Preguntas y respuestas acerca de la instalación:

- **¿Se puede instalar la columna LBC3200 de igual modo que la LBC3210 o LBC3201?**
Esta columna se ha diseñado para interiores de pequeño y mediano tamaño. Su rendimiento acústico óptimo se obtiene transmitiendo el sonido justo por encima de la cabeza de los oyentes. Si la columna se monta de igual modo que la LBC3210 o LBC3201 se obtiene un área de audición muy pequeña, por lo que no se utiliza un ángulo mayor de 6°.

- **¿Se pueden escuchar los tonos agudos si no se ve la columna?**
Puede comparar los tonos agudos con la luz: cuando algún objeto se interpone entre su punto de vista y la fuente de luz, no puede ver ésta completamente. A este fenómeno lo denominamos 'sombra' y es la misma situación que se produce con los tonos agudos. Cuando hay muchas personas sentadas entre el lugar donde se encuentra y el altavoz, se encuentra sentado en la sombra acústica, lo cual se percibe como una reducción de los tonos agudos.

Información adicional:

- Debido al gran número de ángulos de instalación, es difícil proporcionar un contorno definido del sonido irradiado desde la columna.
- Si se instala la columna en un ángulo pequeño, es posible que se obtenga una (muy) pequeña área de audición. En función del nivel de reverberación de la sala y la sombra acústica (personas u objetos delante de un oyente que obstaculizan la fuente directa de sonido), es posible que la inteligibilidad del sonido desde una posición alejada sea baja. En tal caso, es mejor utilizar varias columnas para dividir el área de audición.
- Cuando sobrepasa la posición límite del área de audición (es decir, la distancia máxima a la columna) sólo disminuirá el nivel de presión acústica, ya que no hay apenas variación en el nivel del tono. La disminución del nivel de presión acústica depende en gran medida de la reverberación de la sala.
- Si se encuentra demasiado cerca de la columna (a menos de la distancia mínima) y ha elegido la opción de 5°, percibirá rápidamente una disminución de los tonos agudos.
- Ya que los altavoces están diseñados para transmitir el sonido justo por encima de la cabeza de los oyentes, es preferible no montarlos muy por encima del área de audición.
- Para determinar exactamente los límites del área de audición, debe llevar a cabo una prueba en el lugar de instalación de la columna. Esta prueba es tarea para un oyente con experiencia y oídos bien entrenados. Para llevarla a cabo, reproduzca ruido rosa en la columna. Es preferible reducir los tonos más graves para esta prueba, ya que no contribuyen a la inteligibilidad del sonido. Camine alrededor del área de audición y escuche atentamente los tonos agudos. Los límites del área de audición se encuentran allí donde disminuyen rápidamente los tonos agudos.



Figura 1: vista lateral de la irradiación de la columna montada en la pared con un ángulo pequeño



Figura 2: vista lateral de la irradiación de la columna montada en la pared con un ángulo de 5°

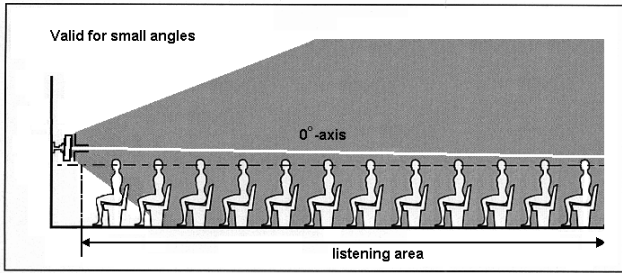

Diagrama 1: relación entre la distancia del área de audición y la columna

Área de audición y altura de montaje correspondiente de XLA3201/00

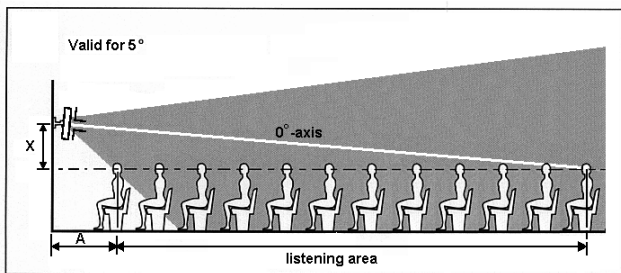
Montaje:

1. Determine las dimensiones del 'área de escucha' deseada (plano horizontal al nivel de los oídos del oyente; consulte la línea discontinua de la figura 1).
2. Calcule la distancia máxima a la columna desde la posición del oyente más alejado en el área de audición (corresponde a 'B' en las figuras 1, 2 y 3).
3. Consulte el diagrama 1 y continúe hacia arriba desde la distancia máxima en el eje horizontal. Desplácese horizontalmente hasta el eje vertical desde la intersección vertical con la línea B diagonal. El valor X (altura del soporte de montaje de la columna por encima del plano de audición, 'X' en la figura 1) aparece sobre este eje. Las intersecciones horizontales con otras líneas diagonales proporcionan información acerca de las dimensiones del área de audición. Estos números están relacionados con las figuras 2 y 3 (consulte también el ejemplo que aparece más abajo).
4. La figura 2 muestra el contorno de octava de 1 kHz irradiado por la columna y la figura 3 muestra la irradiación del contorno de octava de 4 kHz. El área de audición con un rendimiento acústico óptimo se encuentra en dichos contornos. Asegúrese de que el contorno de 4 kHz con las dimensiones obtenidas mediante el diagrama 1 cubre adecuadamente el área de audición deseada.
5. Si el área de audición deseada queda cubierta por el contorno de 4 kHz, el valor X del eje vertical muestra la altura a la que debe montarse la columna por encima del plano de audición. Observe que la columna debe montarse a la altura elegida en un ángulo de 8°.

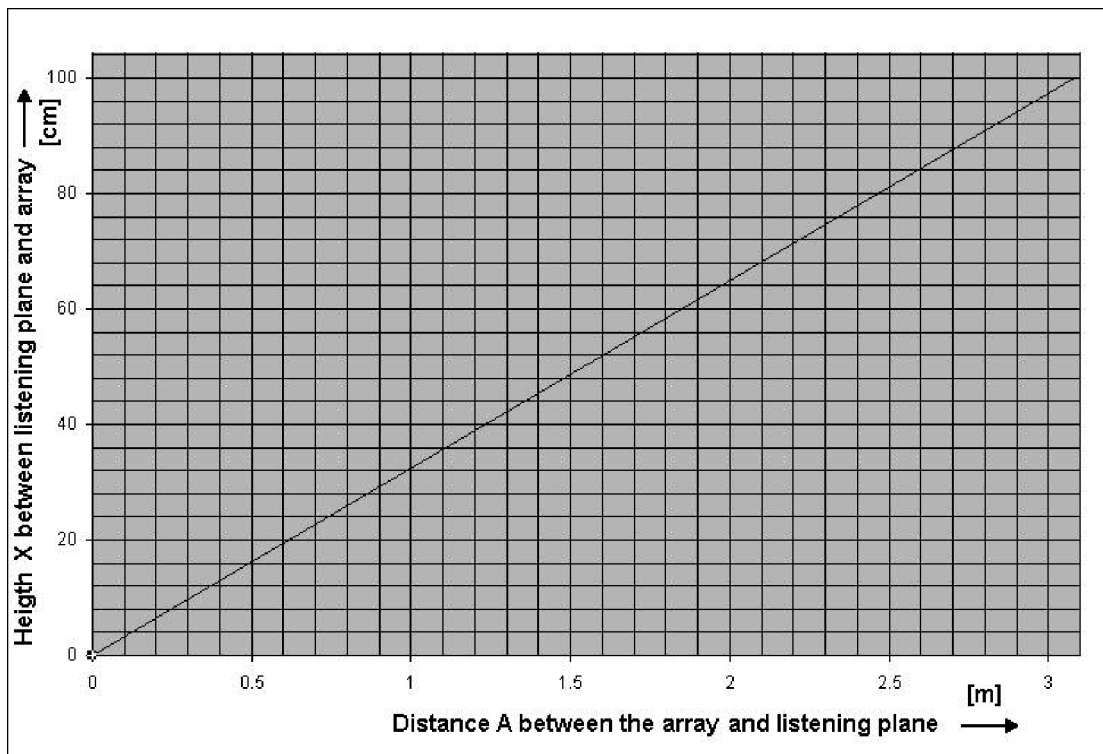
Ya puede montar la columna para un rendimiento acústico óptimo.

Ejemplo:

La distancia máxima desde la columna hasta el último oyente es de 15 m. Si sigue hacia arriba el punto correspondiente a 15 m en el eje horizontal del diagrama 1 hasta la línea B diagonal y luego perpendicularmente al eje vertical, las intersecciones con las otras líneas diagonales facilitan las dimensiones de los planos de audición. En este ejemplo:

Línea F (longitud lateral del plano de audición de 4 kHz) = 11,1 m

Línea C (longitud del plano de audición) = 11 m

Línea E (plano de audición de 4 kHz con la mitad de anchura) = 9,3 m

Línea A (distancia mínima al plano de audición) = 3,9 m

En el eje vertical, el valor X (altura entre el plano de audición y el soporte de montaje de la columna) es igual a 1,8 m.

Preguntas y respuestas acerca de la instalación:

- **El área de audición deseada es demasiado grande y no encaja en el contorno de 4 kHz.**
Pruebe con otra altura de montaje de la columna o utilice más columnas para obtener un área de audición mayor.
- **¿Por qué se debe utilizar un ángulo de 8° para la columna?**
Los contornos irradiados que aparecen en las figuras 2 y 3 con las dimensiones del diagrama 1 sólo son válidos cuando la columna se monta con un ángulo de 8°. Ésta es la única posición que proporciona unos niveles constantes de presión acústica y respuesta de frecuencia (directividad constante) en el área de audición.
- **¿Se puede montar la columna en otro ángulo?**
Puede utilizar las columnas con otros ángulos, pero no obtendrá un rendimiento acústico óptimo. Por ejemplo, percibirá una mayor variación en el nivel de presión acústica. Los valores del diagrama 1 no son válidos para otros ángulos. Se recomienda no utilizar un ángulo mayor de 8°.
- **La columna no se puede montar tan alto como se desea.**
Pruebe por ejemplo a bajar el techo y utilice un ángulo menor de 8°. Enfoque el eje 0° de la columna hacia la posición máxima deseada (consulte la figura 4). Observe que la tabla del diagrama 1 y los contornos de las figuras 2 y 3 no son válidos en este caso. Compruebe que la inteligibilidad del sonido del área de audición es aceptable.

Información adicional:

- Los contornos se definen para un entorno anecoico. Si estos contornos se encuentran en condiciones anecoicas, cuenta con una variación máxima de la presión acústica de 6 dB y una variación de la respuesta de frecuencia percibida mucho menor. En áreas de reverberación normal o alta, se produce una menor variación del nivel de presión acústica y el tamaño de los contornos es mayor. La respuesta de frecuencia percibida en este contorno será casi constante.
- Si sobrepasa el área de audición (es decir, supera la distancia máxima a la columna), sólo disminuirá el nivel de presión acústica. No hay apenas variación en el nivel del tono. La disminución del nivel de presión acústica depende en gran medida de la reverberación de la sala.
- Si se encuentra demasiado cerca de las columnas (a menos de la distancia mínima), percibirá rápidamente la falta de tonos agudos.

- En función del nivel de reverberación de la sala y la sombra acústica (personas u objetos delante de un oyente que obstaculizan la fuente directa de sonido), es posible que la inteligibilidad del sonido sea baja en las posiciones más alejadas. En tal caso, es mejor utilizar varias columnas para dividir el área de audición.
- Las líneas laterales de los contornos de las figuras 2 y 3 son los puntos de -6 dB relacionados con el nivel de presión acústica del eje 00.
- Para obtener la mejor inteligibilidad del sonido posible, defina un área de audición que quede completamente cubierta por el contorno de octava de 4 kHz.
- Para determinar exactamente los límites del área de audición, debe llevar a cabo una prueba en el lugar de instalación de la columna. Esta prueba es tarea para un oyente con experiencia y oídos bien entrenados. Para llevarla a cabo, reproduzca ruido rosa en la columna. Es preferible reducir los tonos más graves para esta prueba, ya que no contribuyen a la inteligibilidad del sonido. Camine alrededor del área de audición y escuche atentamente los tonos agudos. Los límites del área de audición se encuentran allí donde disminuyen rápidamente los tonos agudos.



Diagrama 1: relación entre el área de audición y la altura de montaje de la columna

Significado de las líneas diagonales

Línea B: distancia máxima desde la columna hasta el último oyente

Línea D: plano de audición de 1 kHz con la mitad de anchura

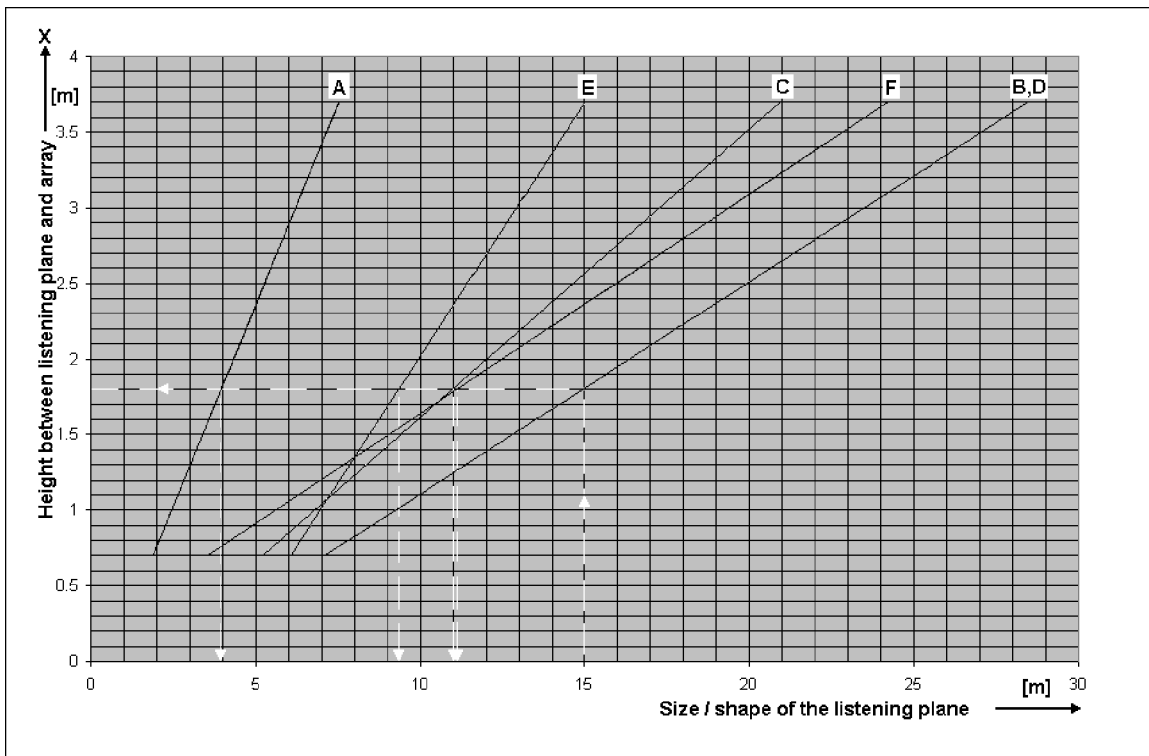
Línea F: longitud lateral del plano de audición de 4 kHz

Línea C: longitud del plano de audición

Línea E: plano de audición de 4 kHz con la mitad de anchura

Línea A: distancia mínima al plano de audición



Figura 1: vista lateral del plano de audición e irradiación de la columna



Figura 2: contorno de octava de 1 kHz de la columna

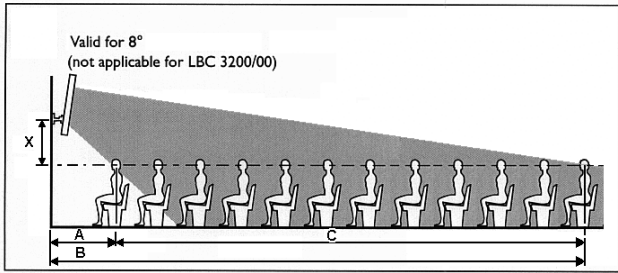

Figura 3: contorno de octava de 4 kHz de la columna

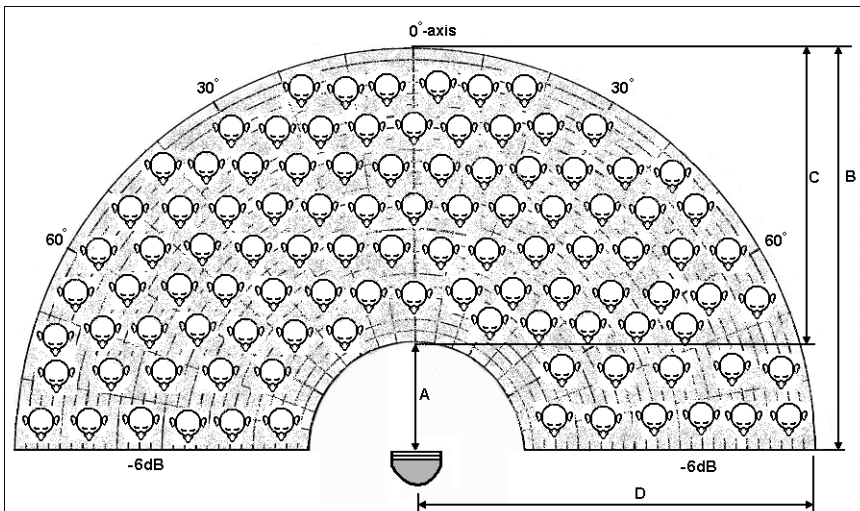

Figura 4: enfoque el eje 0° de la columna hacia la posición máxima deseada

Área de audición y altura de montaje correspondiente de XLA3210/00

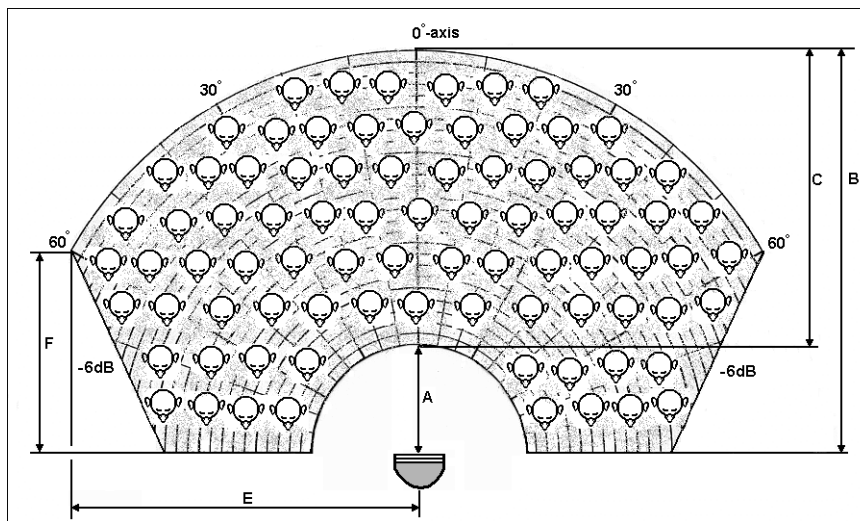
Montaje:

1. Determine las dimensiones del 'área de escucha' deseada (plano horizontal al nivel de los oídos del oyente; consulte la línea discontinua de la figura 1).
2. Calcule la distancia máxima a la columna desde la posición del oyente más alejado en el área de audición (corresponde a 'B' en las figuras 1, 2 y 3).
3. Consulte el diagrama 1 y continúe hacia arriba desde la distancia máxima en el eje horizontal. Desplácese horizontalmente hasta el eje vertical desde la intersección vertical con la línea B diagonal. El valor X (altura del soporte de montaje de la columna por encima del plano de audición, 'X' en la figura 1) aparece sobre este eje. Las intersecciones horizontales con otras líneas diagonales proporcionan información acerca de las dimensiones del área de audición. Estos números están relacionados con las figuras 2 y 3 (consulte también el ejemplo que aparece más abajo).
4. La figura 2 muestra el contorno de octava de 1 kHz irradiado por la columna y la figura 3 muestra la irradiación del contorno de octava de 4 kHz. El área de audición con un rendimiento acústico óptimo se encuentra en dichos contornos. Asegúrese de que el contorno de 4 kHz con las dimensiones obtenidas mediante el diagrama 1 cubre adecuadamente el área de audición deseada.
5. Si el área de audición deseada queda cubierta por el contorno de 4 kHz, el valor X del eje vertical muestra la altura a la que debe montarse la columna por encima del plano de audición. Observe que la columna debe montarse a la altura elegida en un ángulo de 8°.

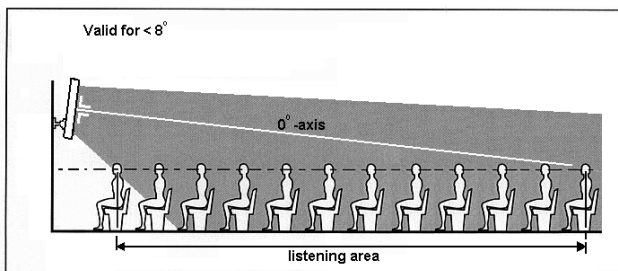
Ya puede montar la columna para un rendimiento acústico óptimo.

Ejemplo del diagrama:

La distancia máxima desde la columna hasta el último oyente es de 15 m. Si sigue hacia arriba el punto correspondiente a 15 m en el eje horizontal del diagrama 1 hasta la línea B diagonal y luego perpendicularmente al eje vertical, las intersecciones con las otras líneas diagonales facilitan las dimensiones de los planos de audición. En este ejemplo:

Línea F (longitud lateral del plano de audición de 4 kHz) = 12,2 m

Línea C (longitud del plano de audición) = 11 m

Línea E (plano de audición de 4 kHz con la mitad de anchura) = 8,6 m

Línea A (distancia mínima al plano de audición) = 3,9 m

En el eje vertical, el valor X (altura entre el plano de audición y el soporte de montaje de la columna) es igual a 1,8 m.

Preguntas y respuestas acerca de la instalación:

- **El área de audición deseada es demasiado grande y no encaja en el contorno de 4 kHz.**

Pruebe con otra altura de montaje de la columna o utilice más columnas para obtener un área de audición mayor.

- **¿Por qué se debe utilizar un ángulo de 8° para la columna?**

Los contornos irradiados que aparecen en las figuras 2 y 3 con las dimensiones del diagrama 1 sólo son válidos cuando la columna se monta con un ángulo de 8°. Ésta es la única posición que proporciona unos niveles constantes de presión acústica y respuesta de frecuencia (directividad constante) en el área de audición.

- **¿Se puede montar la columna en otro ángulo?**

Puede utilizar las columnas con otros ángulos, pero no obtendrá un rendimiento acústico óptimo. Por ejemplo, percibirá una mayor variación en el nivel de presión acústica. Los valores del diagrama 1 no son válidos para otros ángulos. Se recomienda no utilizar un ángulo mayor de 8°.

- **La columna no se puede montar tan alto como se desea.**

Pruebe por ejemplo a bajar el techo y utilice un ángulo menor de 8°. Enfoque el eje 0° de la columna hacia la posición máxima deseada (consulte la figura 4). Observe que la tabla del diagrama 1 y los contornos de las figuras 2 y 3 no son válidos en este caso. Compruebe que la inteligibilidad del sonido del área de audición es aceptable, asegurándose de que los mensajes sean audibles.

Información adicional:

- Los contornos se definen para un entorno anecoico. Si estos contornos se encuentran en condiciones anecoicas, cuenta con una variación máxima de la presión acústica de 6 dB y una variación de la respuesta de frecuencia percibida mucho menor. En áreas de reverberación normal o alta, se produce una menor variación del nivel de presión acústica y el tamaño de los contornos es mayor. La respuesta de frecuencia percibida en este contorno será casi constante.
- Si sobrepasa el área de audición (es decir, supera la distancia máxima a la columna), sólo disminuirá el nivel de presión acústica. No hay apenas variación en el nivel del tono. La disminución del nivel de presión acústica depende en gran medida de la reverberación de la sala.
- Si se encuentra demasiado cerca de las columnas (a menos de la distancia mínima), percibirá rápidamente la falta de tonos agudos.
- En función del nivel de reverberación de la sala y la sombra acústica (personas u objetos delante de un oyente que obstaculizan la fuente directa de sonido),

es posible que la inteligibilidad del sonido sea baja en las posiciones más alejadas. En tal caso, es mejor utilizar varias columnas para dividir el área de audición.

- Las líneas laterales de los contornos de las figuras 2 y 3 son los puntos de -6 dB relacionados con el nivel de presión acústica del eje 0° .
- Para obtener la mejor inteligibilidad del sonido posible, defina un área de audición que quede completamente cubierta por el contorno de octava de 4 kHz.

Para determinar exactamente los límites del área de audición, debe llevar a cabo una prueba en el lugar de instalación de la columna. Esta prueba es tarea para un oyente con experiencia y oídos bien entrenados. Para llevarla a cabo, reproduzca ruido rosa en la columna. Es preferible reducir los tonos más graves para esta prueba, ya que no contribuyen a la inteligibilidad del sonido. Camine alrededor del área de audición y escuche atentamente los tonos agudos. Los límites del área de audición se encuentran allí donde disminuyen rápidamente los tonos agudos.



Diagrama 1: relación entre el área de audición y la altura de montaje de la columna

Significado de las líneas

- Línea B: distancia máxima desde la columna hasta el último oyente
- Línea D: plano de audición de 1 kHz con la mitad de anchura
- Línea F: longitud lateral del plano de audición de 4 kHz
- Línea C: longitud del plano de audición
- Línea E: plano de audición de 4 kHz con la mitad de anchura
- Línea A: distancia mínima al plano de audición

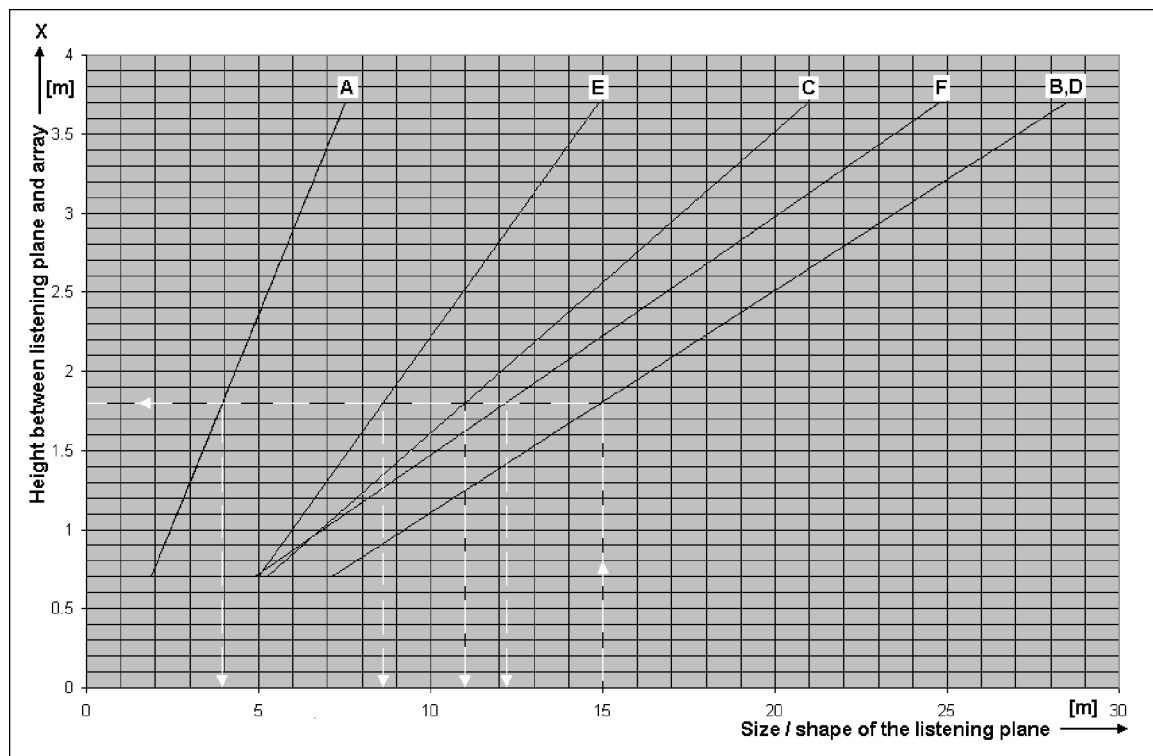

Figura 1: vista lateral del plano de audición e irradiación de la columna



Figura 2: contorno de octava de 1 kHz de la columna

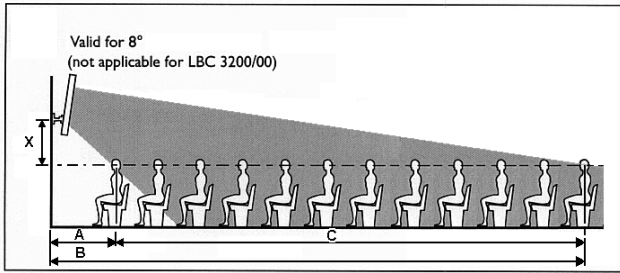

Figura 3: contorno de octava de 4 kHz de la columna

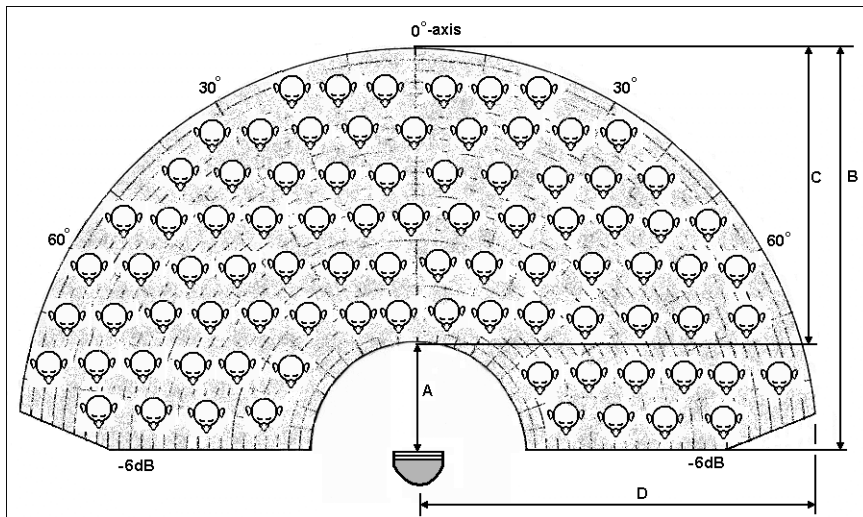

Figura 4: enfoque el eje 0° de la columna hacia la posición máxima deseada

DATOS DE RENDIMIENTO TÉCNICO**LBC 3200/00**

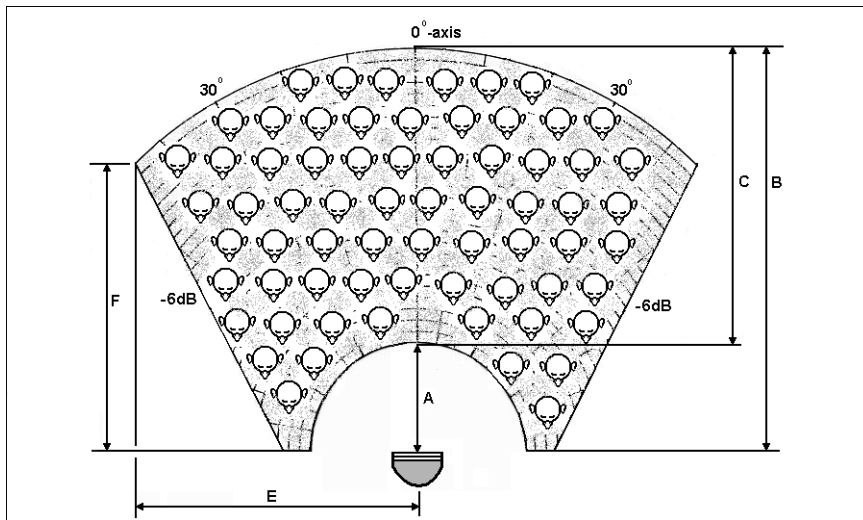
Potencia máxima	45 W
Potencia nominal	30 W (30-15-7,5 W)
Nivel de presión acústica a	
30 W/1 W (a 1 kHz, 1 m)	106 dB/91 dB (NPA)
Rango de frecuencia efectiva (-10 dB)	de 190 Hz a 18 kHz
Ángulo de apertura	
(a 1 kHz/4 kHz, -6 dB)	
Horizontal	220° /130°
Vertical	70° /18°
Voltaje de entrada nominal	100 V
Impedancia nominal	333 ohmios
Temperatura ambiente	de -25°C a +55°C
Seguridad	conforme a las directivas de EN 60065
Conexión	cuadro de clavijas
Dimensiones (Al x An x L)	600 x 80 x 90 mm
Color	plateado
Peso	3 kg

**LBC 3200/00**

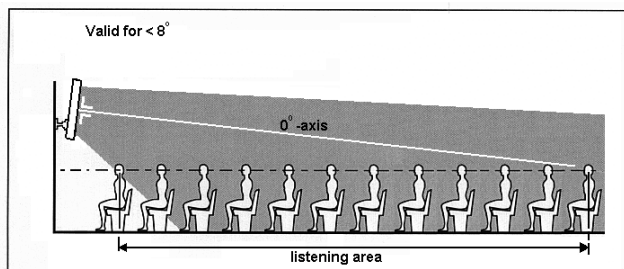
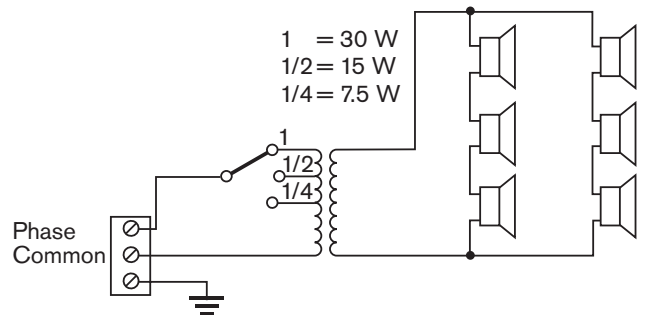
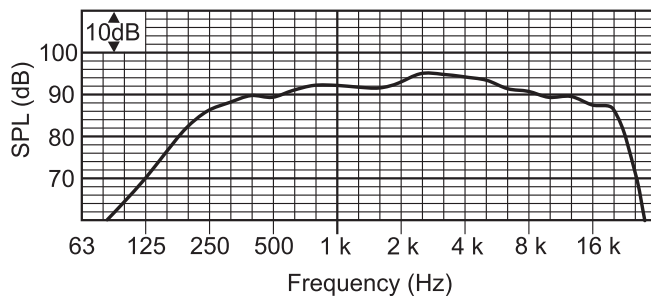
Banda de octavas (Hz)	250	500	1 k	2 k	4 k	8 k
NPA 1,1	87	89	91	93	93	89
NPA máx.	102	104	106	108	108	104
Factor Q	1,3	2,2	4,5	11,6	25,7	58,9
Ángulo horizontal (grados)	360	360	220	190	130	100
Ángulo vertical (grados)	360	120	70	32	18	10

Horizontal

Vertical

LBC 3200/00
250Hz horizontal

LBC 3200/00
250Hz vertical

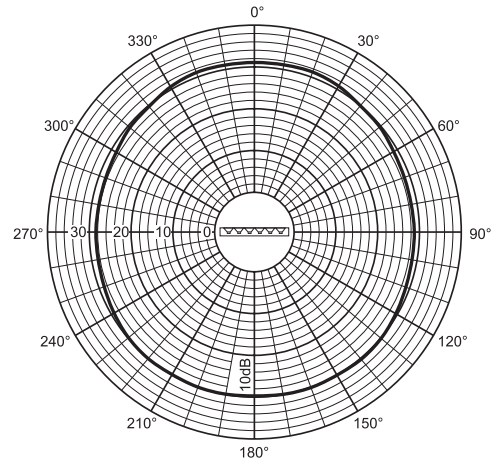
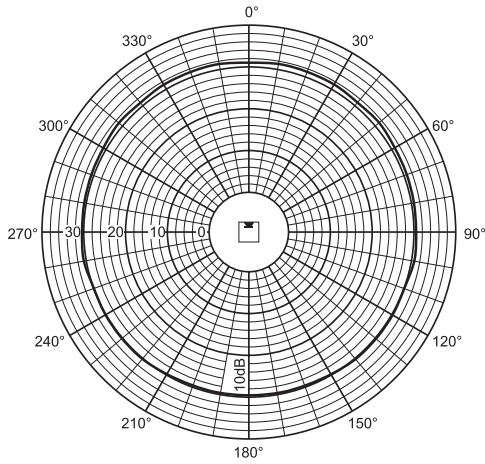

LBC 3200/00
500Hz horizontal

LBC 3200/00
500Hz vertical

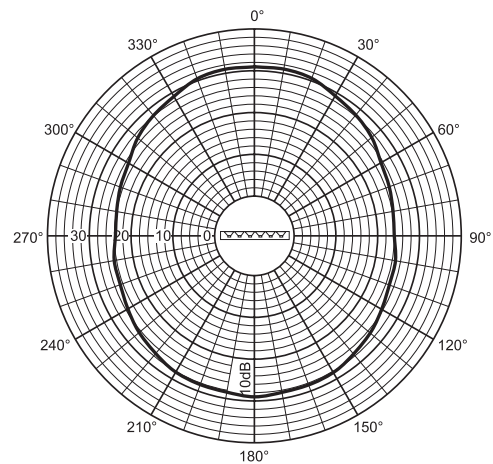
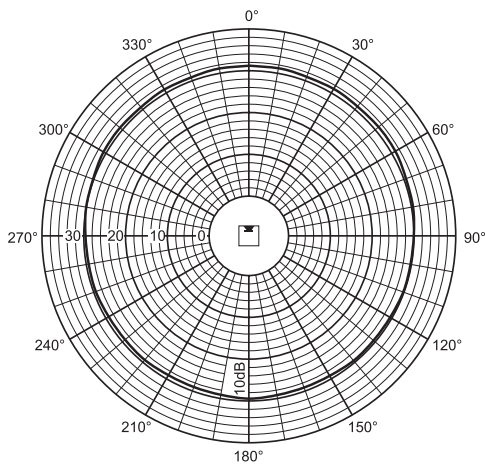

LBC 3200/00
1kHz horizontal

LBC 3200/00
1kHz vertical

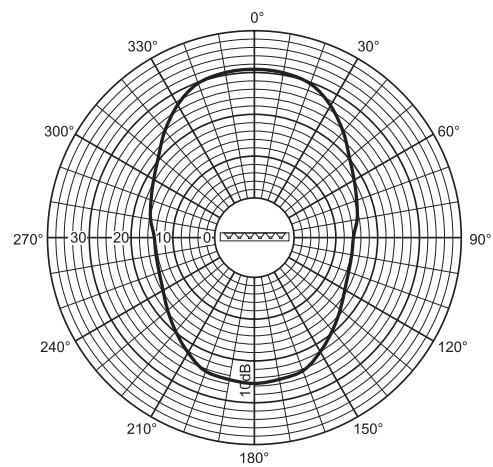
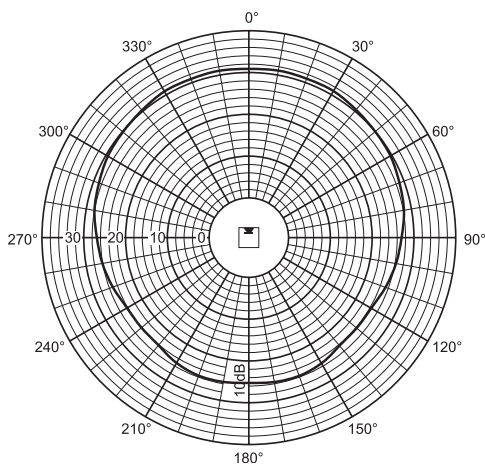

Horizontal

Vertical

LBC 3200/00
2kHz horizontal

LBC 3200/00
2kHz vertical

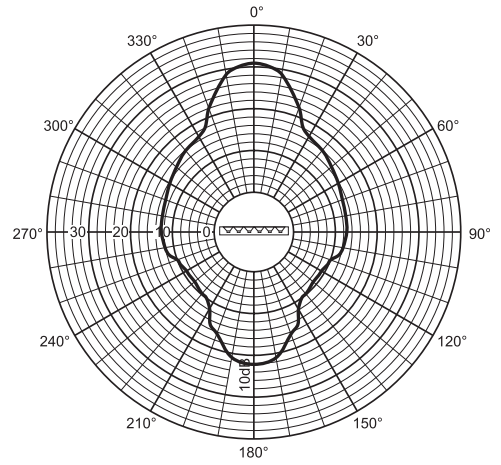
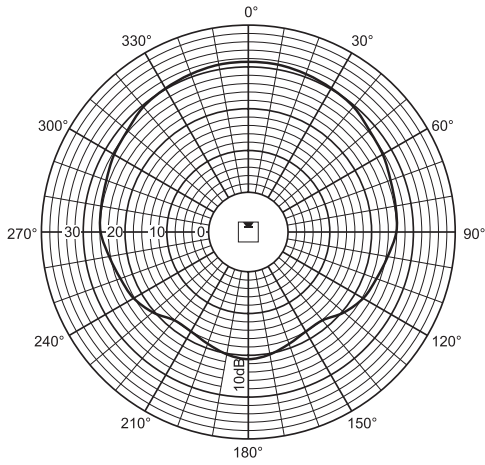

LBC 3200/00
4kHz horizontal

LBC 3200/00
4kHz vertical

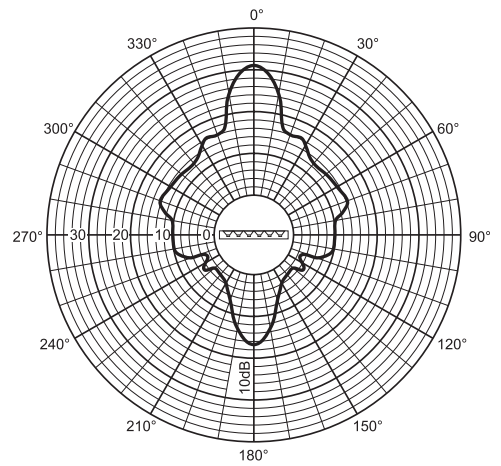
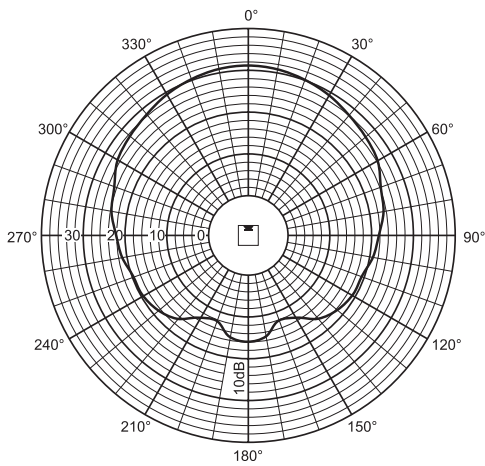

LBC 3200/00
8kHz horizontal

LBC 3200/00
8kHz vertical

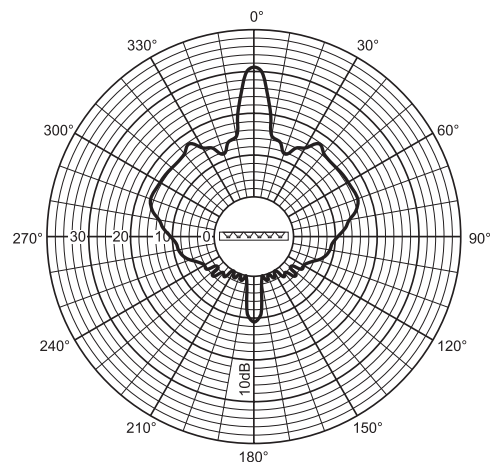
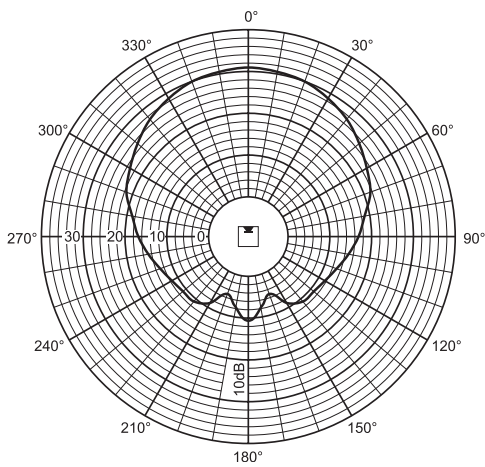

DATOS DE RENDIMIENTO TÉCNICO**LBC 3201/00**

Potencia máxima	90 W
Potencia nominal	60 W (60-30-15 W)
Nivel de presión acústica a	
60 W/1 W (a 1 kHz, 1 m)	110 dB/92 dB (NPA)
Rango de frecuencia efectiva (-10 dB)	de 190 Hz a 18 kHz
Ángulo de apertura	
(a 1 kHz / 4 kHz, - 6 dB)	
Horizontal	210°/132°
Vertical	50°/22°
Voltaje de entrada nominal	100 V
Impedancia nominal	167 ohmios
Temperatura ambiente	de -25°C a +55°C
Seguridad	conforme a las directivas de EN 60065
Conexión	cuadro de clavijas
Dimensiones (Al x An x L)	1200 x 80 x 90 mm
Color	plateado
Peso	6,4 kg

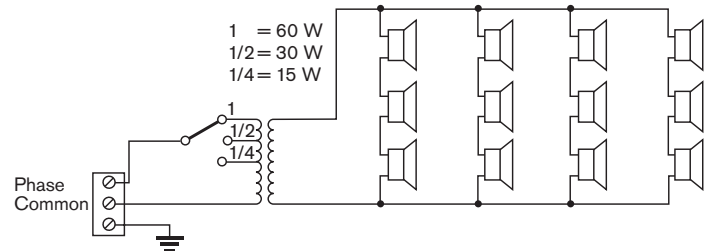
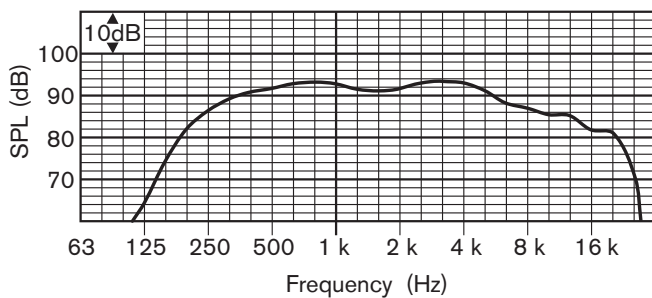
**LBC 3201/00**

Banda de octavas (Hz)	250	500	1 k	2 k	4 k	8 k
NPA 1,1	88	92	92	91	91	86
NPA máx.	106	110	110	109	109	104
Factor Q	2,2	3,2	6,5	12,6	23,4	53,3
Ángulo horizontal (grados)	360	360	210	192	132	100
Ángulo vertical (grados)	107	67	50	33	22	12

Horizontal

Vertical

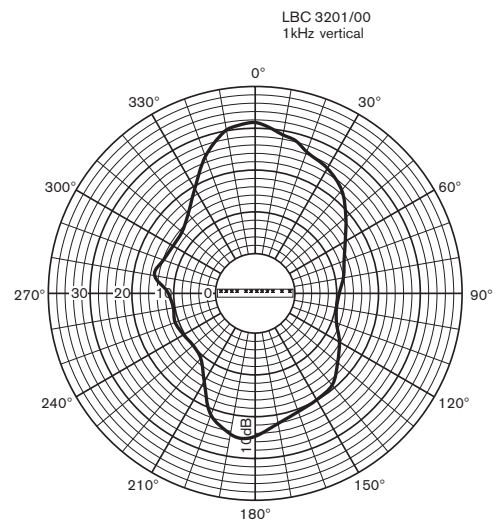
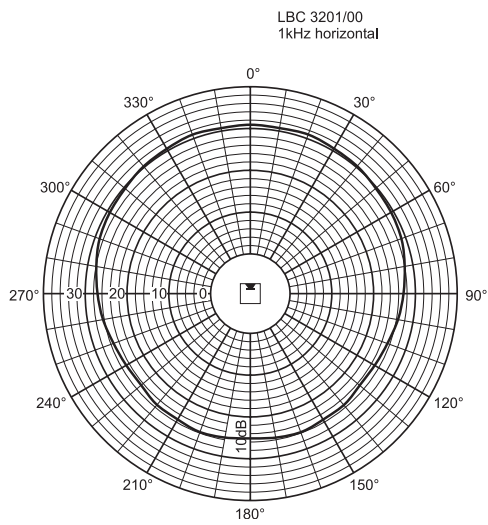
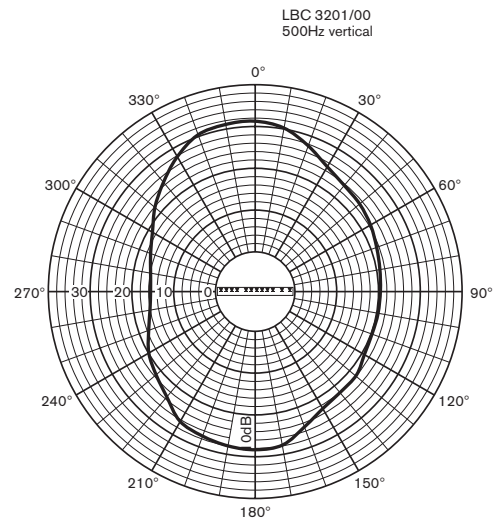
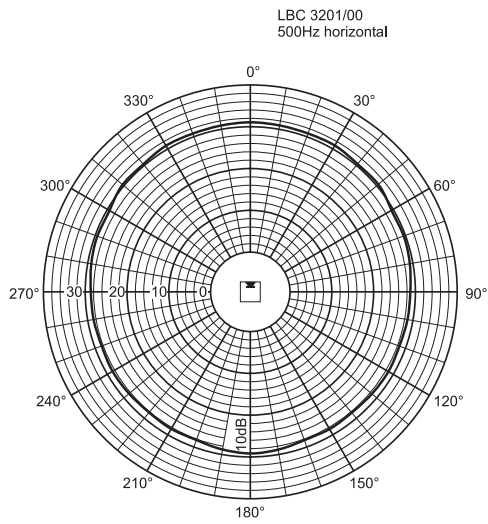
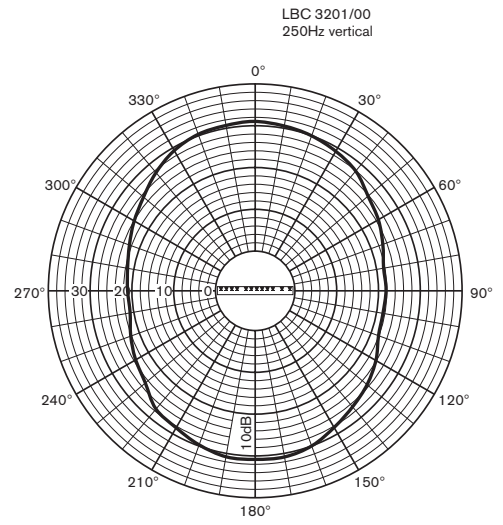
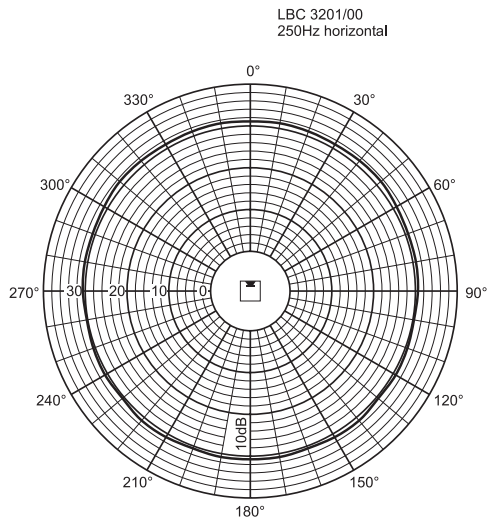

Horizontal

Vertical

LBC 3201/00
2kHz horizontal

LBC 3201/00
2kHz vertical

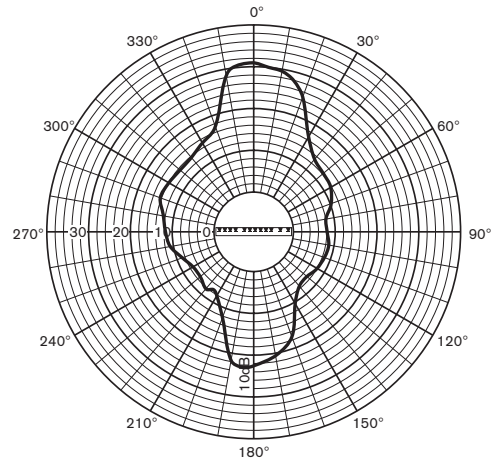
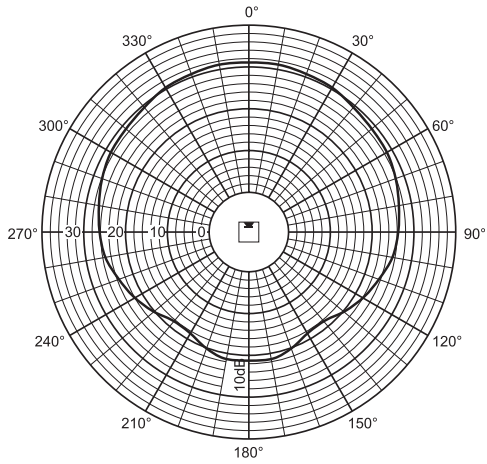

LBC 3201/00
4kHz horizontal

LBC 3201/00
4kHz vertical

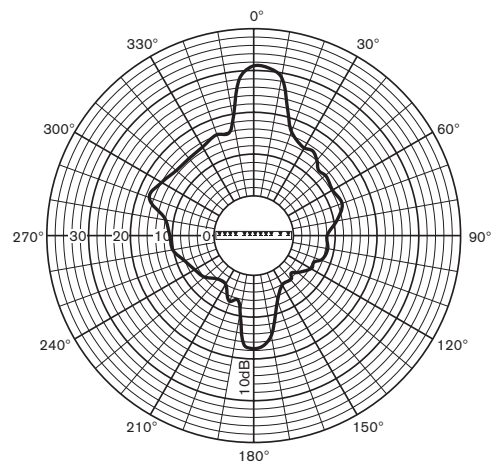
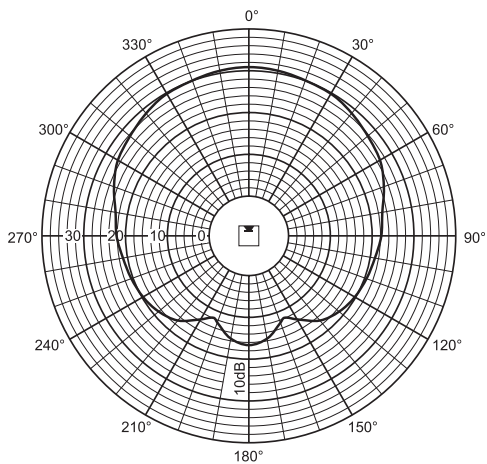

LBC 3201/00
8kHz horizontal

LBC 3201/00
8kHz vertical

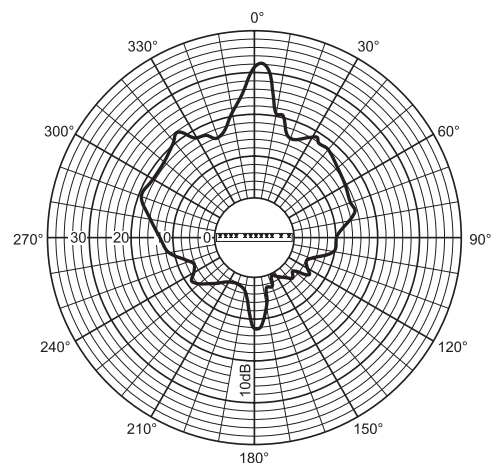
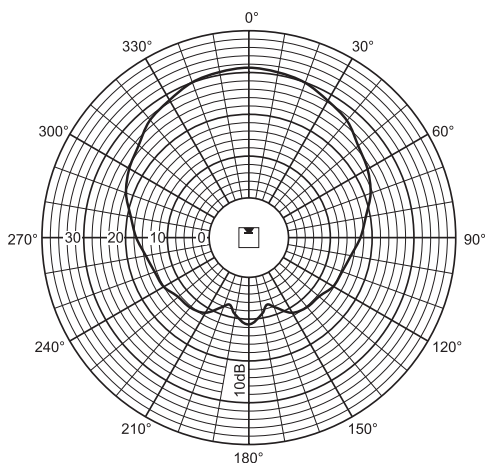

DATOS DE RENDIMIENTO TÉCNICO**LBC 3210/00**

Potencia máxima	90 W
Potencia nominal	60 W (60-30-15 W)
Nivel de presión acústica	
a 60 W/1 W (a 1 kHz, 1 m)	115 dB/97 dB (NPA)
Rango de frecuencia efectiva (-10 dB)	de 190 Hz a 20 kHz
Ángulo de apertura	
(a 1 kHz / 4 kHz, - 6 dB)	
Horizontal	170°/90°
Vertical	55°/18°
Voltaje de entrada nominal	100 V
Impedancia nominal	167 ohmios
Temperatura ambiente	de -25°C a +55°C
Seguridad	conforme a las directivas de EN 60065
Protección contra el agua/polvo	IP 66 conforme a IEC 60529
Conexión	cuadro de clavijas
Dimensiones (Al x An x L)	1200 x 160 x 90 mm
Color	plateado
Peso	9 kg

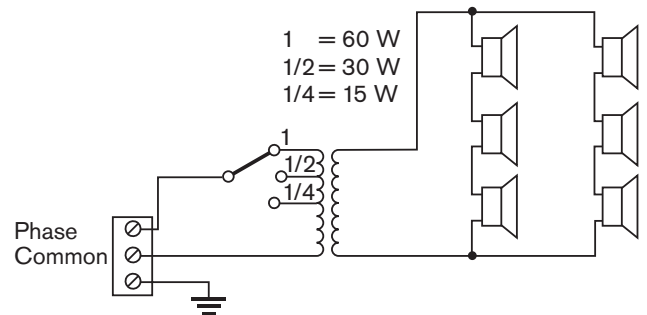
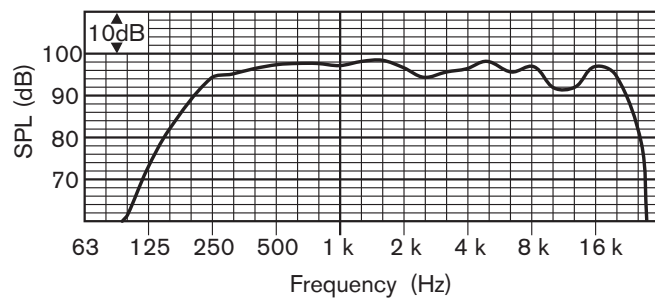
**LBC 3210/00**

Banda de octavas (Hz)	250	500	1 k	2 k	4 k	8 k
NPA 1,1	94	97	97	95	96	93
NPA máx.	112	115	115	113	114	111
Factor Q	2,2	2,7	6,3	10,8	22,6	32,3
Ángulo horizontal (grados)	360	180	170	160	90	60
Ángulo vertical (grados)	100	60	55	34	18	10

Horizontal

Vertical

LBC 3210/00
250Hz horizontal

LBC 3210/00
250Hz vertical

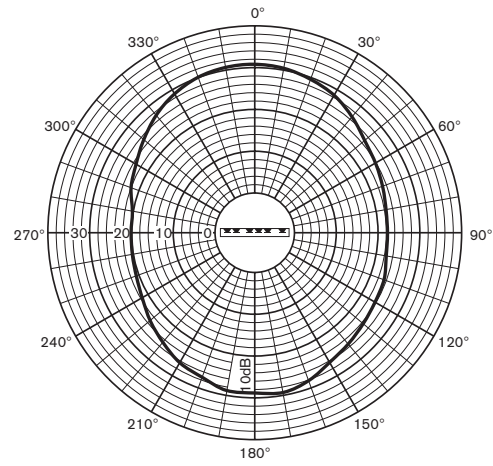
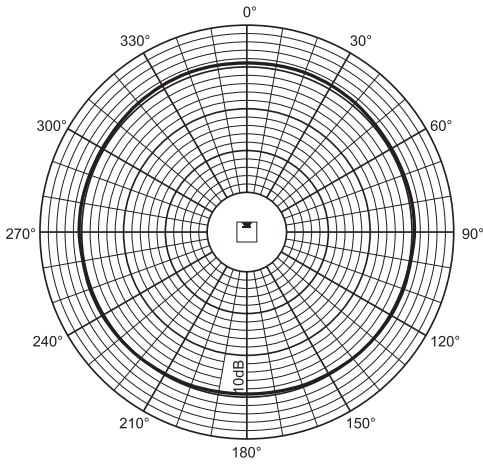

LBC 3210/00
500Hz horizontal

LBC 3210/00
500Hz vertical

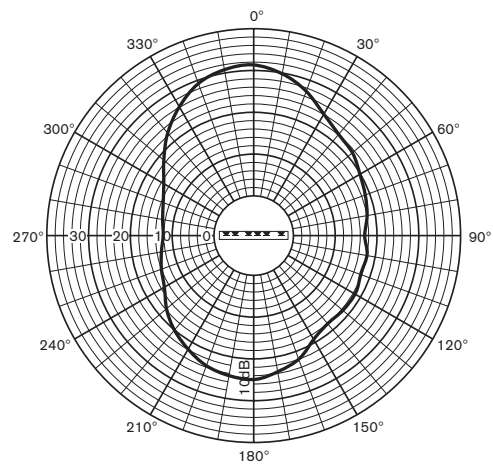
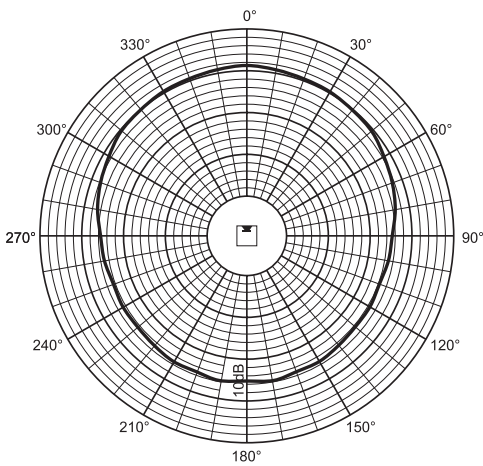

LBC 3210/00
1kHz horizontal

LBC 3210/00
1kHz vertical

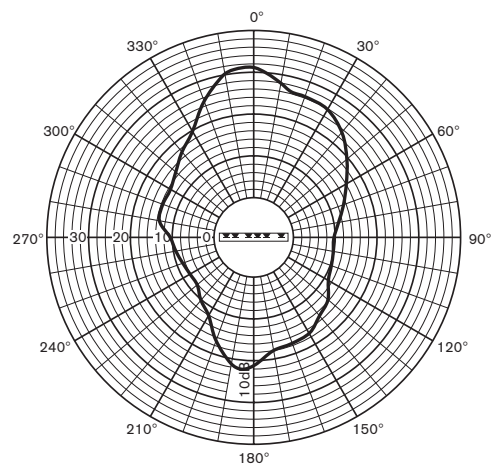
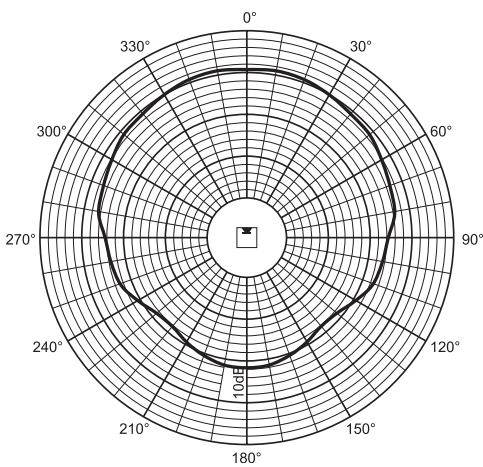

Horizontal

Vertical

LBC 3210/00
2kHz horizontal

LBC 3210/00
2kHz vertical

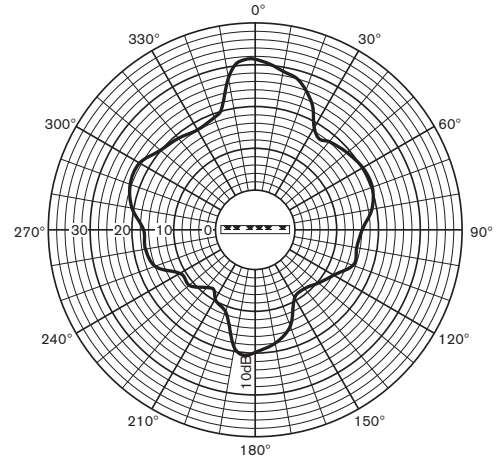
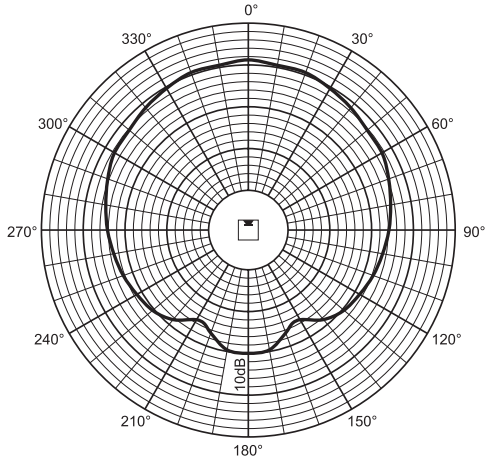

LBC 3210/00
4kHz horizontal

LBC 3210/00
4kHz vertical

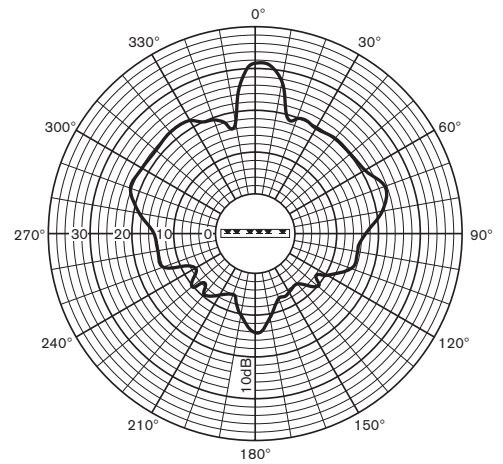
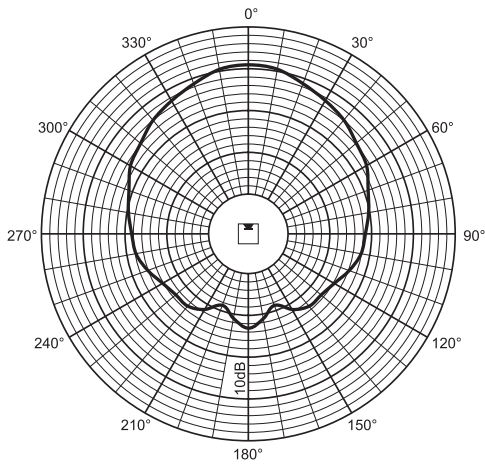

LBC 3210/00
8kHz horizontal

LBC 3210/00
8kHz vertical

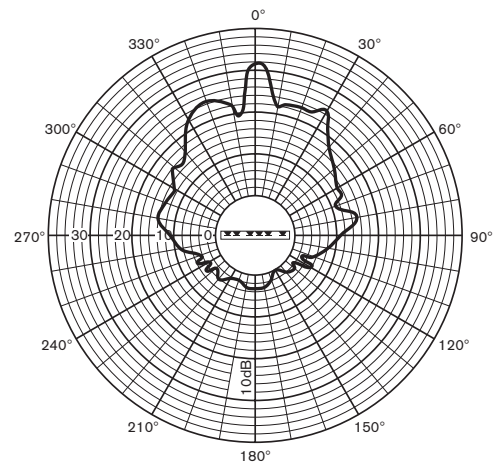
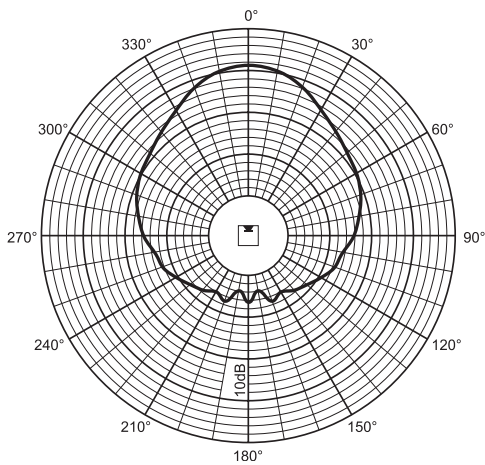

www.boschsecuritysystems.com

BOSCH

Inhoud	Pagina
Installatiehandleiding (afb. 1 - afb. 17)	94
Bevestiging lijn/luidspreker-bewakingsbord (optioneel) (afb. A1 - afb. A5).....	96
Bevestiging extra beugel (optioneel) (afb. B1 - afb. B5)	96
Bevestiging vloerstatief (optioneel) (afb. C1 - afb. C3)	96
Luistergebied en bijbehorende bevestigingshoogte voor LBC 3200/00	97
Luistergebied en bijbehorende bevestigingshoogte voor LBC 3201/00	99
Luistergebied en bijbehorende bevestigingshoogte voor LBC 3210/00	102
Technische gegevens LBC 3200/00	105
Technische gegevens LBC 3201/00	108
Technische gegevens LBC 3210/00	111

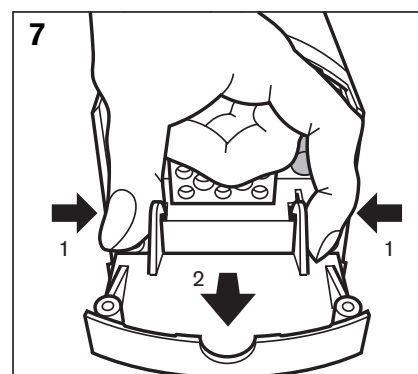
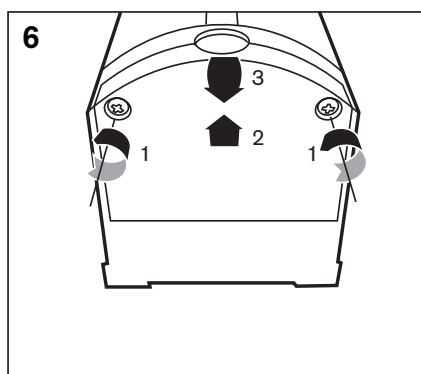
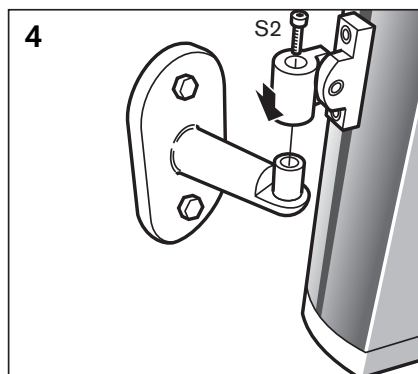
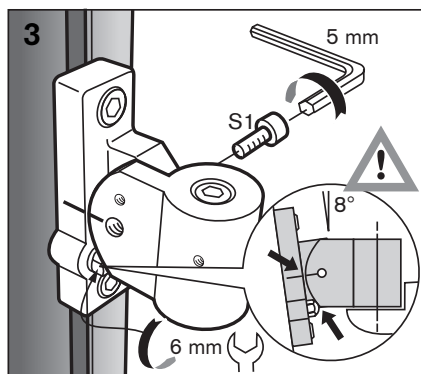
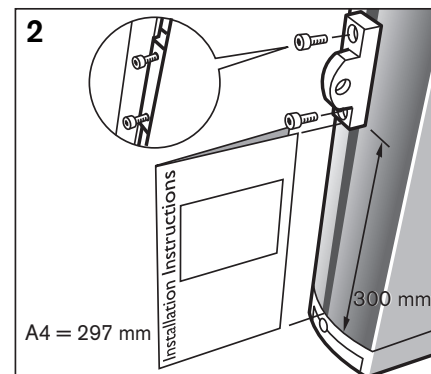
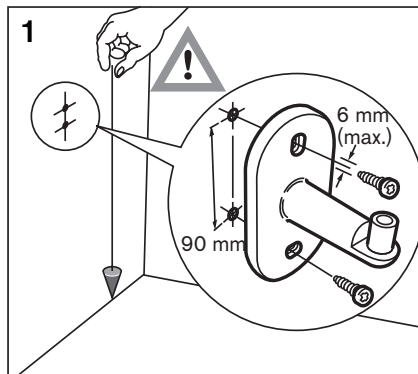
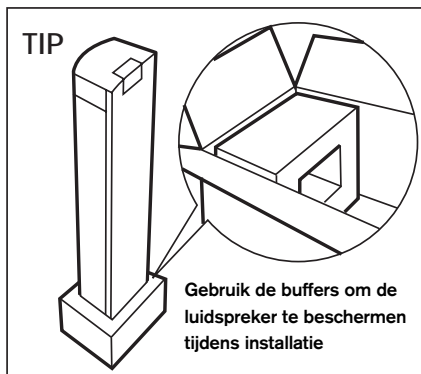
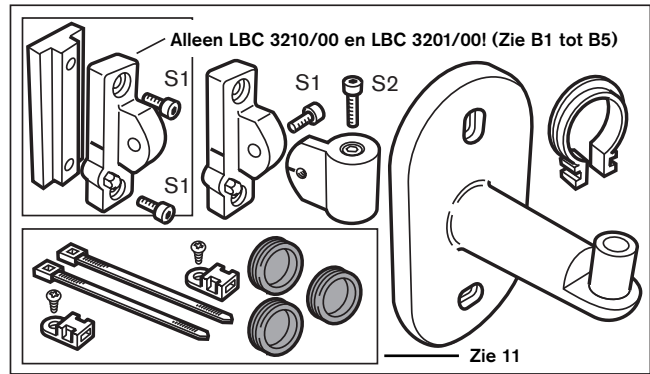
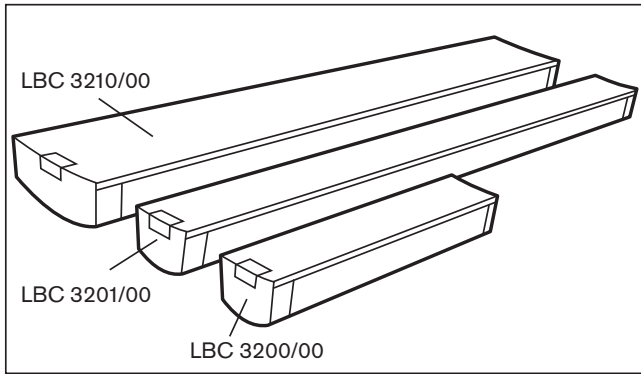

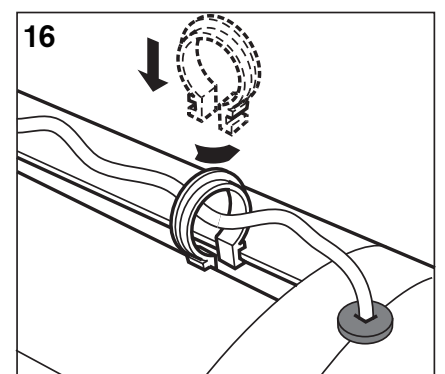
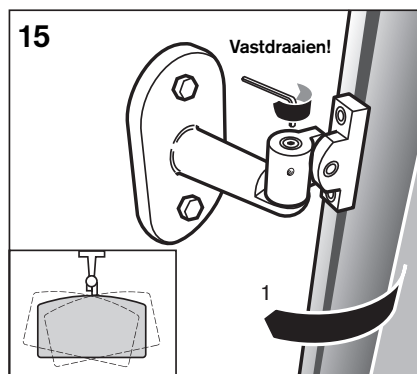
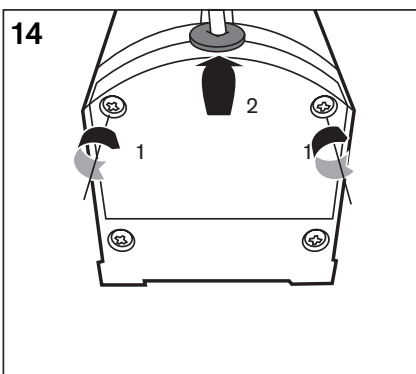
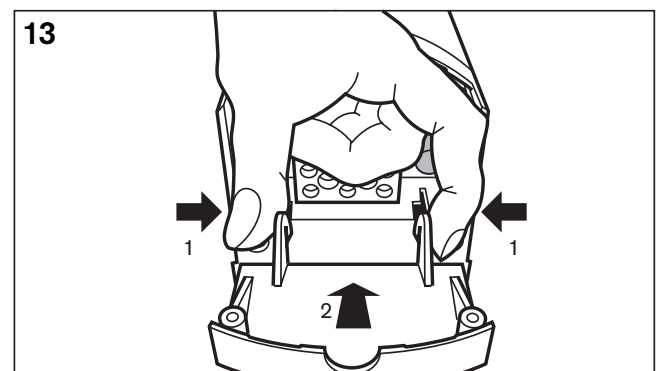
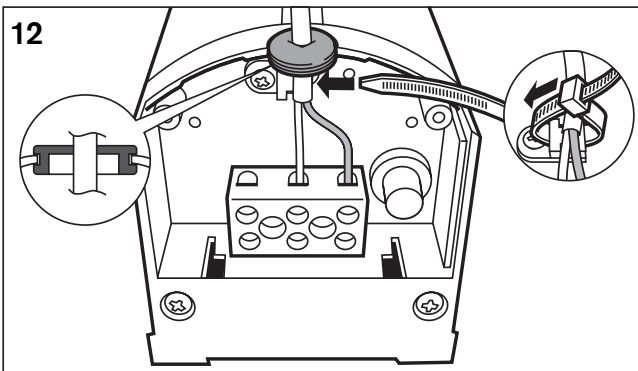
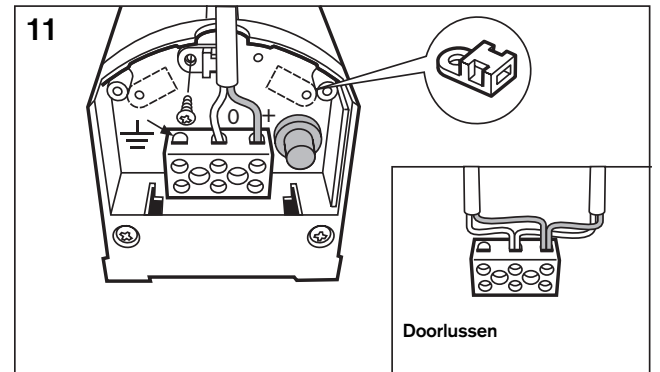
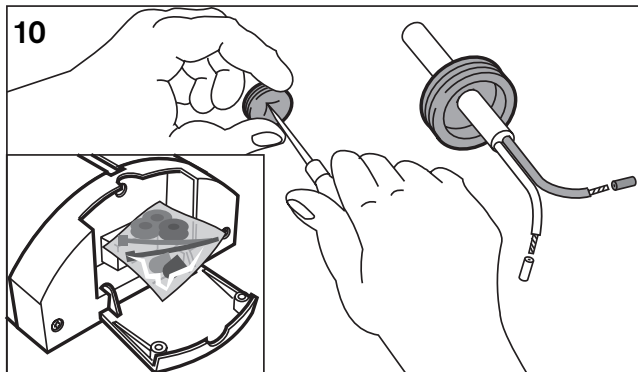
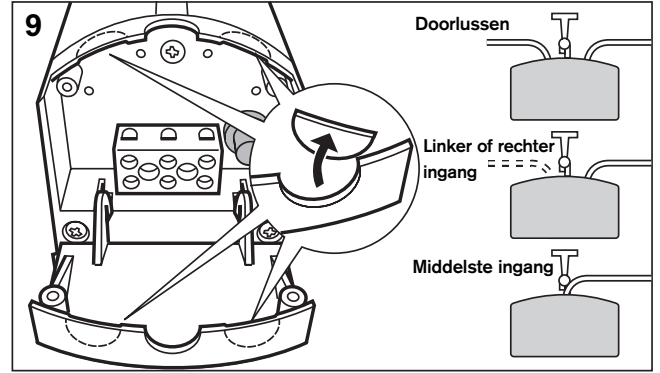
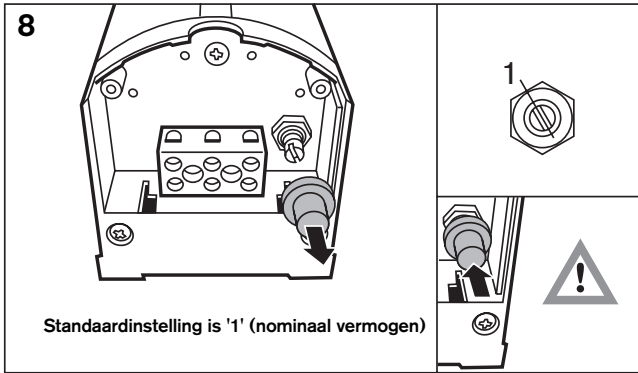

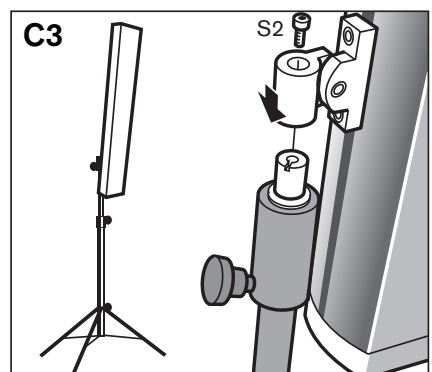
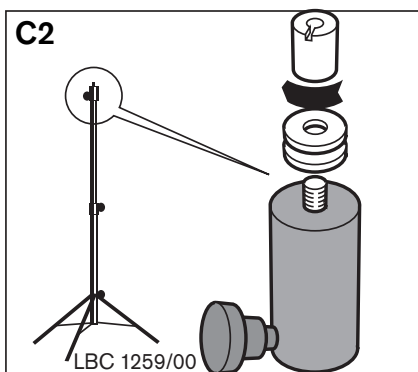
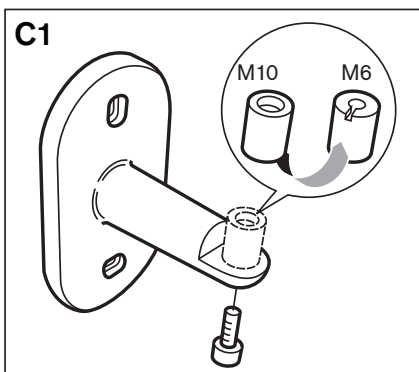
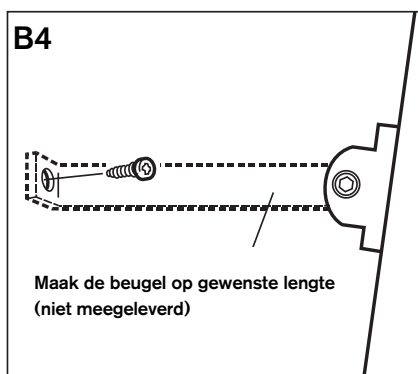
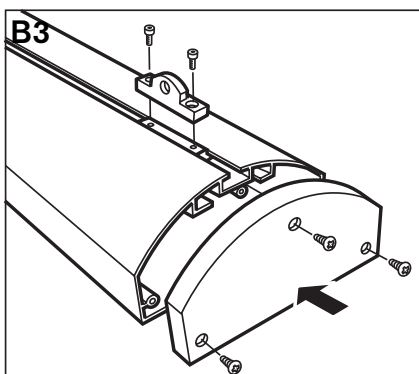
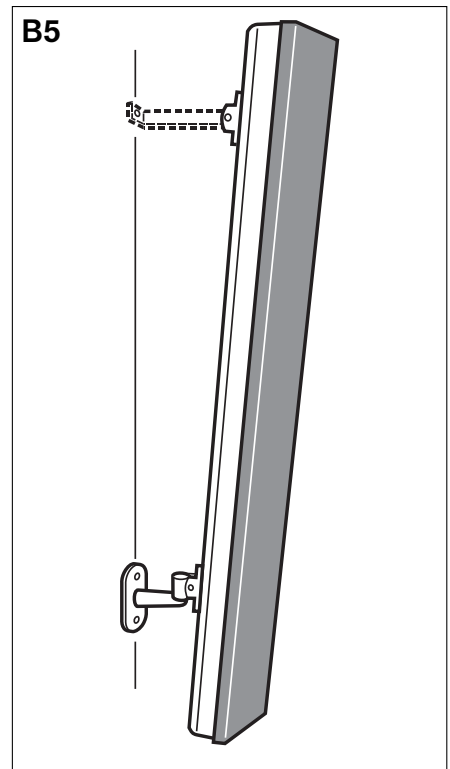
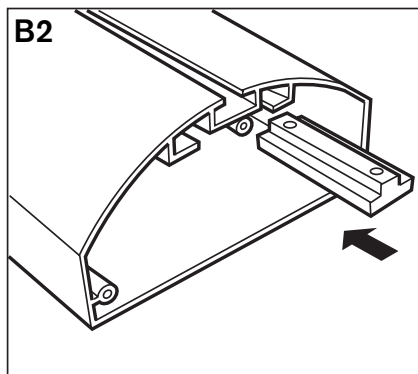
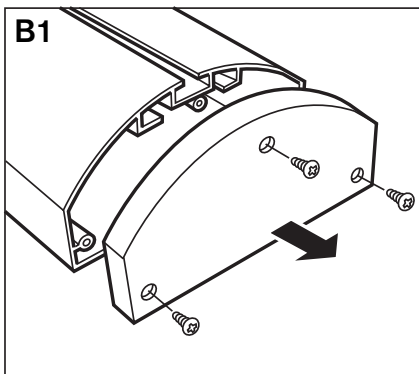
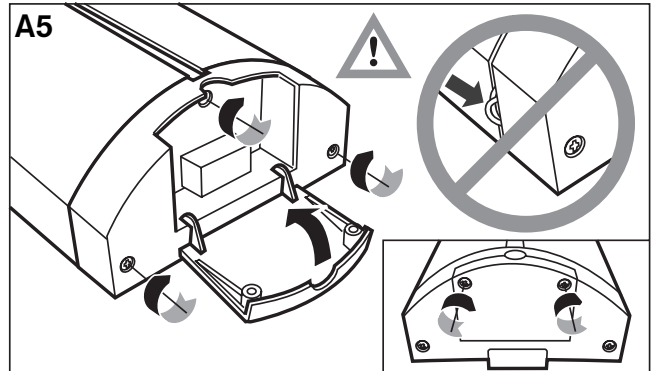
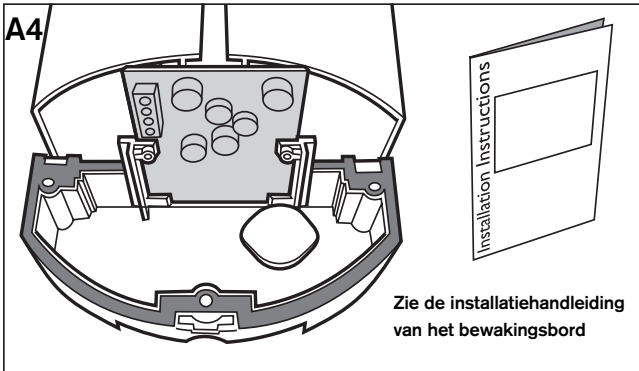
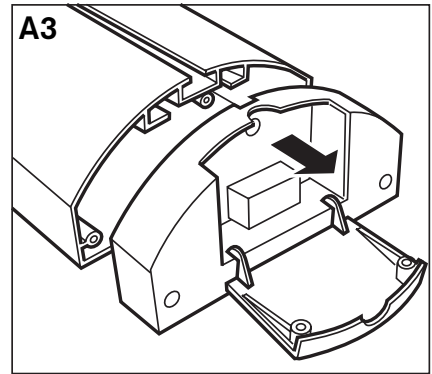
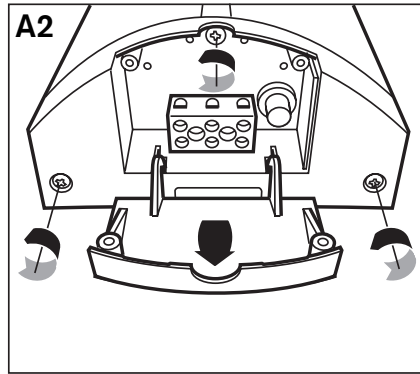
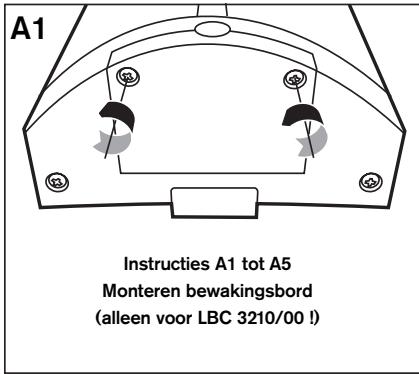

Luistergebied en bijbehorende bevestigingshoogte voor XLA3200/00

Bevestigingshoogte en -hoek bepalen voor de LBC3200 Line Array luidspreker:

1. Bepaal de afmetingen van het gewenste 'luistergebied' (een horizontaal vlak op het niveau van de oren van de toehoorders – zie de stippellijn in afbeelding 1).
2. Bepaal de hoek waaronder de Line Array luidspreker moet worden bevestigd. Het systeem is bedoeld om het geluid precies boven de hoofden van de toehoorders te richten. Het verdient aanbeveling geen grotere hoek dan 6 graden te nemen. Er zijn twee benaderingen, elk met specifieke voors en tegens.
 - Benadering 1: maximaal luistergebied
Wanneer een groot luistergebied gewenst is, wordt een hoek van rond de 3° aanbevolen (zie afbeelding 1). Wanneer men zich van de Line Array luidspreker vandaan beweegt, neemt het geluidsdrukkniveau af in een mate die afhangt van de weerkaatsing van de ruimte. Om hoge tonen duidelijk te horen, moet de toehoorder de Line Array luidspreker kunnen zien.
 - Benadering 2: minimale variatie in geluidsdrukkniveau
Wanneer zo min mogelijk variatie in geluidsdrukkniveau gewenst is, wordt een hoek van 5° aanbevolen. Hierdoor wordt de grootte van het totale luistergebied in vergelijking met benadering 1 kleiner en maakt de ruimte vlak bij de Line Array luidspreker ('A' in afbeelding 2) geen deel uit van het luistergebied. Diagram 1 toont de relatie tussen 'A' en de bevestigingshoogte van de Line Array luidspreker bij gebruik van een installatiehoek van 5°.
3. Nadat de meest geschikte benadering is gekozen (bevestigingshoek), wordt de bevestigingshoogte van de luidspreker bepaald door de 0°-as van de Line Array luidspreker te richten op de gewenste positie, precies boven het oorniveau van de verste toehoorder. Dit kan worden aangepast door de luidspreker hoger of lager aan de wand te bevestigen.

Nu kunt u de Line Array luidspreker zodanig bevestigen dat de optimale akoestische karakteristieken worden bereikt.

Vragen en antwoorden met betrekking tot de installatie:

- **Kan ik de LBC3200 Line Array luidspreker op dezelfde wijze installeren als de LBC3210 of LBC3201?**
De LBC3200 is bestemd voor kleine en middelgrote inpandige ruimtes. De optimale akoestische karakteristieken van dit luidsprekersysteem worden bereikt door het geluid precies boven de hoofden van de toehoorders te richten. Wanneer deze Line Array luidspreker op dezelfde wijze wordt bevestigd als de LBC3210 of LBC3201, resulteert dit in een zeer klein

luistergebied. Om dezelfde reden dient geen grotere hoek dan 6° te worden gebruikt.

- Als ik de Line Array luidspreker niet kan zien, betekent dit dan dat ik hoge tonen niet kan horen?
U kunt hoge tonen vergelijken met licht. Wanneer zich tussen u en de lichtbron iets bevindt, ziet u de lichtbron niet op zijn volledige sterkte. We noemen dit schaduw. Dezelfde situatie doet zich voor bij hoge tonen. Wanneer zich tussen u en de luidspreker veel mensen bevinden, zit u in de 'geluidschaduw'. We ervaren dit als een afname van hoge tonen.

Achtergrondinformatie:

- Vanwege de vele installatiehoeken is het moeilijk om een eenduidige vorm aan te geven van het geluid dat door de Line Array luidspreker wordt uitgestraald.
- Door de Line Array luidspreker onder een kleine hoek te installeren, kan een (zeer) groot luistergebied worden bereikt. Al naar gelang de mate van weerkaatsing in de ruimte en de geluidschaduw (mensen of voorwerpen die zich voor een toehoorder bevinden en de rechtstreekse geluidsbron blokkeren), kan de spraakverstaanbaarheid op een verafgelegen positie gering zijn. In dergelijke situaties is het beter meerdere luidsprekersystemen te gebruiken om het luistergebied op te splitsen.
- Wanneer u verder weg gaat dan de maximale positie van het luistergebied (voorbij de maximale afstand van de Line Array luidspreker), neemt alleen het geluidsdrukkniveau af. Er is vrijwel geen variatie in toonhoogte. De afname van het geluidsdrukkniveau hangt sterk af van de weerkaatsing van de ruimte.
- Wanneer u te dicht bij de Line Array luidspreker bent (dichterbij dan de minimale afstand van de Line Array luidspreker) en de 5°-benadering hebt gekozen, zal al heel snel een afname van de hoge tonen optreden.
- Omdat de luidsprekers zijn ontworpen om het geluid precies boven de hoofden van de toehoorders te richten, is het beter om de luidsprekers niet te hoog boven het luistergebied te bevestigen.
- Om de grenzen van het luistergebied in uw situatie exact te kunnen bepalen, dient u een praktijktest uit te voeren op de locatie waar de Line Array luidspreker wordt geïnstalleerd. Dit is een taak voor een ervaren luisteraar met goedgetrainde oren. Voor deze test stuurt u Pink Noise door de Line Array luidspreker. Het is beter om de lage tonen voor deze test terug te draaien, aangezien deze niet bijdragen tot de spraakverstaanbaarheid. Loop rond in het luistergebied en luister naar de hoge tonen. De plaatsen waar de hoge tonen snel afnemen, zijn de grenzen van het luistergebied.

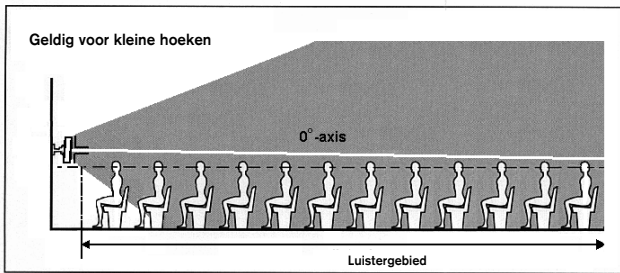

Afbeelding 1: zijaanzicht van uitstraling van de Line Array luidspreker bevestigd onder een kleine hoek aan de wand

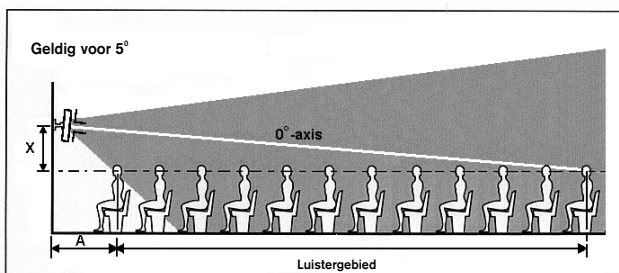

Afbeelding 2: zijaanzicht van uitstraling van de Line Array luidspreker bevestigd onder een hoek van 5° aan de wand

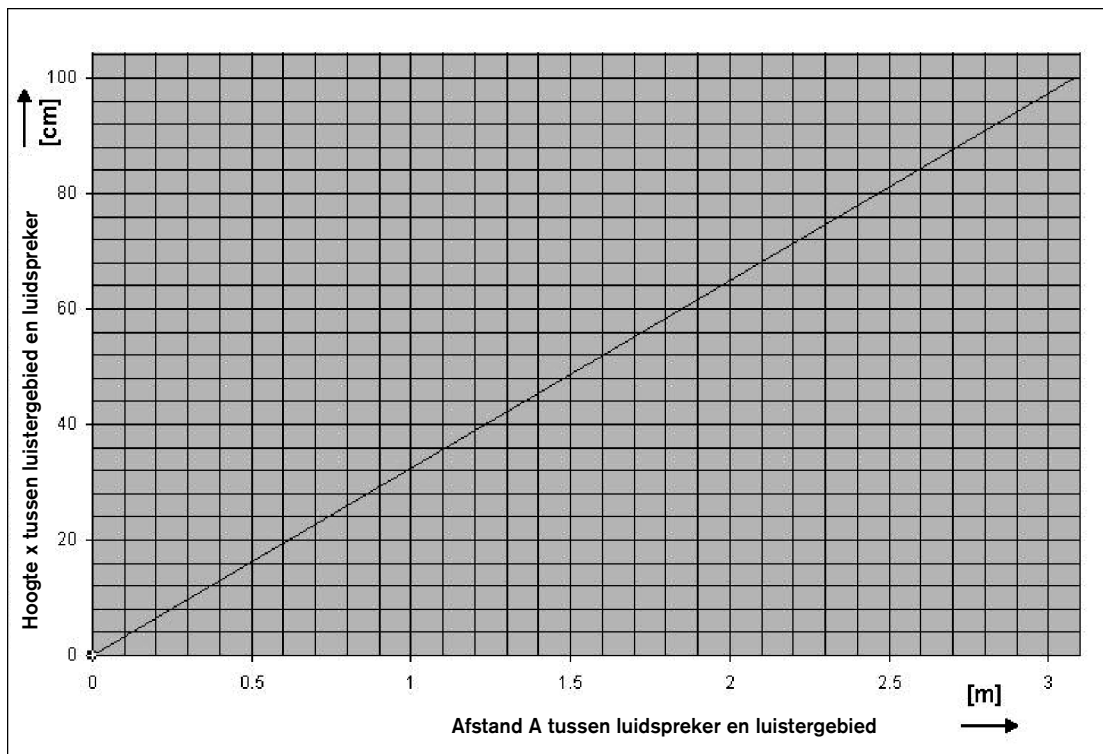

Diagram 1: relatie tussen luistergebied-afstand en Line Array luidspreker

Luistergebied en bijbehorende bevestigingshoogte voor XLA3201/00

Zo gebruikt u deze bevestigingsmethode:

1. Bepaal de afmetingen van het gewenste 'luistergebied' (een horizontaal vlak op het niveau van de oren van de toehoorders – zie de stippellijn in afbeelding 1).
2. Meet de maximale afstand van de Line Array luidspreker tot de achterste toehoorder in het luistergebied (corresponderend met 'B' in afbeelding 1, 2 en 3).
3. Raadpleeg diagram 1 en ga omhoog van de maximale afstand op de horizontale as. Vanaf het verticale kruispunt met de diagonale B-lijn gaat u horizontaal naar de verticale as. De X-waarde (hoogte van bevestigingsbeugel van luidsprekersysteem boven het luistervlak, 'X' in afbeelding 1) is afgezet langs deze as. De horizontale kruispunten met andere diagonale lijnen geven informatie over de afmetingen van het luistergebied. Deze getallen hebben ook betrekking op afbeelding 2 en 3 (zie ook het onderstaande voorbeeld).
4. Afbeelding 2 toont de 1kHz-octaafvorm die wordt uitgestraald door de Line Array luidspreker. Afbeelding 3 toont de uitstraling bij de 4kHz-octaafvorm. Het luistergebied met de optimale akoestische karakteristieken bevindt zich in deze vormen. Controleer of de 4kHz-vorm met de afmetingen zoals verkregen uit diagram 1, het gewenste luistergebied afdoende dekt.
5. Als het gewenste luistergebied wordt afgedekt door de 4kHz-vorm, geeft de X-waarde op de verticale as aan op welke hoogte de Line Array luidspreker moet worden bevestigd boven het luistervlak. Let erop dat de Line Array luidspreker moet worden bevestigd onder een hoek van 8° op de gekozen hoogte!

Nu kunt u de Line Array luidspreker zodanig bevestigen dat de optimale akoestische karakteristieken worden bereikt.

Voorbeeld:

De maximale afstand van de Line Array luidspreker tot de achterste toehoorder is 15m. Als u vanaf het 15m-punt op de horizontale as van diagram 1 omhoog gaat naar de diagonale B-lijn en daarna zijwaarts naar de verticale as, geven de kruispunten met de andere diagonale lijnen de afmetingen van de luistervlakken aan. In dit voorbeeld geldt:

F-lijn (zijlengte luistervlak van 4kHz) = 11,1 m

C-lijn (lengte luistervlak) = 11 m

E-lijn (halve breedte luistervlak van 4kHz) = 9,3 m

A-lijn (minimale afstand tot luistervlak) = 3,9 m

Op de verticale as is de X-waarde (de hoogte tussen het luistervlak en de bevestigingsbeugel van de Line Array luidspreker) 1,8m.

Vragen en antwoorden met betrekking tot de installatie:

- **Het gewenste luistergebied is te groot en past niet in de 4kHz-vorm.**
Probeer de Line Array luidspreker op een andere hoogte te bevestigen of gebruik meerdere Line Array luidsprekers om een groter luistergebied te bereiken.
- **Waarom een hoek van 8° voor de Line Array luidspreker gebruiken?**
De uitstralingsvormen zoals weergegeven in afbeelding 2 en 3 met de afmetingen in diagram 1, gelden alleen wanneer de Line Array luidspreker is bevestigd onder een hoek van 8°. Alleen in deze situatie is er sprake van een constant geluidsdrukniveau en frequentiebereik (constante gevoeligheid) in het luistergebied.
- **Kan ik de Line Array luidspreker onder een andere hoek gebruiken?**
U kunt de Line Array luidspreker ook onder een andere hoek gebruiken, maar dan worden de optimale akoestische karakteristieken niet bereikt. Er is dan bijvoorbeeld een grotere variatie in het geluidsdrukniveau hoorbaar in het luistergebied. De waarden in diagram 1 gelden niet voor andere hoeken. Het verdient aanbeveling nooit een grotere hoek dan 8° te gebruiken.
- **De Line Array luidspreker kan niet op de gewenste hoogte worden bevestigd.**
Als de gewenste hoogte niet haalbaar is vanwege bijvoorbeeld de hoogte van het plafond, gebruikt u een hoek van minder dan 8°. Richt de 0°-as van de Line Array luidspreker op de gewenste maximale positie (zie afbeelding 4). Let erop dat de tabel in diagram 1 en de vormen in afbeelding 2 en 3 niet gelden voor deze situatie. Controleer in het luistergebied of de spraakverstaanbaarheid acceptabel is.

Achtergrondinformatie:

- De vormen zijn gedefinieerd in een echo-loze omgeving. Bij echo-loze omstandigheden is er in deze vormen een maximale variatie in geluidsdruk van 6 dB en is er veel minder variatie in het frequentiebereik waarneembaar. In omgevingen met een normaal of hoog weerkaatsingsniveau is er minder variatie in het geluidsdrukniveau en is de omvang van de vormen groter. Het waargenomen frequentiebereik in deze vorm is dan nagenoeg constant.
- Wanneer u verder weg gaat dan de maximale positie van het luistergebied (voorbij de maximale afstand van de Line Array luidspreker), neemt alleen het geluidsdrukniveau af. Er is vrijwel geen variatie in toonhoogte. De afname van het geluidsdrukniveau hangt sterk af van de weerkaatsing van de ruimte.

- Wanneer u te dicht bij de Line Array luidspreker bent (dichterbij dan de minimale afstand van de Line Array luidspreker), zal al heel snel een afname van de hoge tonen optreden.
- Al naar gelang de mate van weerkaatsing in de ruimte en de geluidschaduw (mensen of voorwerpen die zich voor een toehoorder bevinden en de rechtstreekse geluidsbron blokkeren), kan de spraakverstaanbaarheid op de verste positie gering zijn. In dergelijke situaties is het beter meerdere luidsprekersystemen te gebruiken om het luistergebied op te splitsen.
- De zijlijnen van de vormen in afbeelding 2 en 3 zijn de -6 dB punten in relatie tot het geluidsdrukkniveau op de 0° -as.
- Om de beste spraakverstaanbaarheid te bereiken, definieert u een luistergebied waarin de 4 kHz-octafvorm het hele gebied afdekt.
- Om de grenzen van het luistergebied in uw situatie exact te kunnen bepalen, dient u een praktijktest uit te voeren op de locatie waar de Line Array luidspreker wordt geïnstalleerd. Dit is een taak voor een ervaren luisteraar met goedgetrainde oren. Voor deze test stuurt u Pink Noise door de Line Array luidspreker. Het is beter om de lage tonen voor deze test terug te draaien, aangezien deze niet bijdragen tot de spraakverstaanbaarheid. Loop rond in het luistergebied en luister naar de hoge tonen. De plaatsen waar de hoge tonen snel afnemen, zijn de grenzen van het luistergebied.

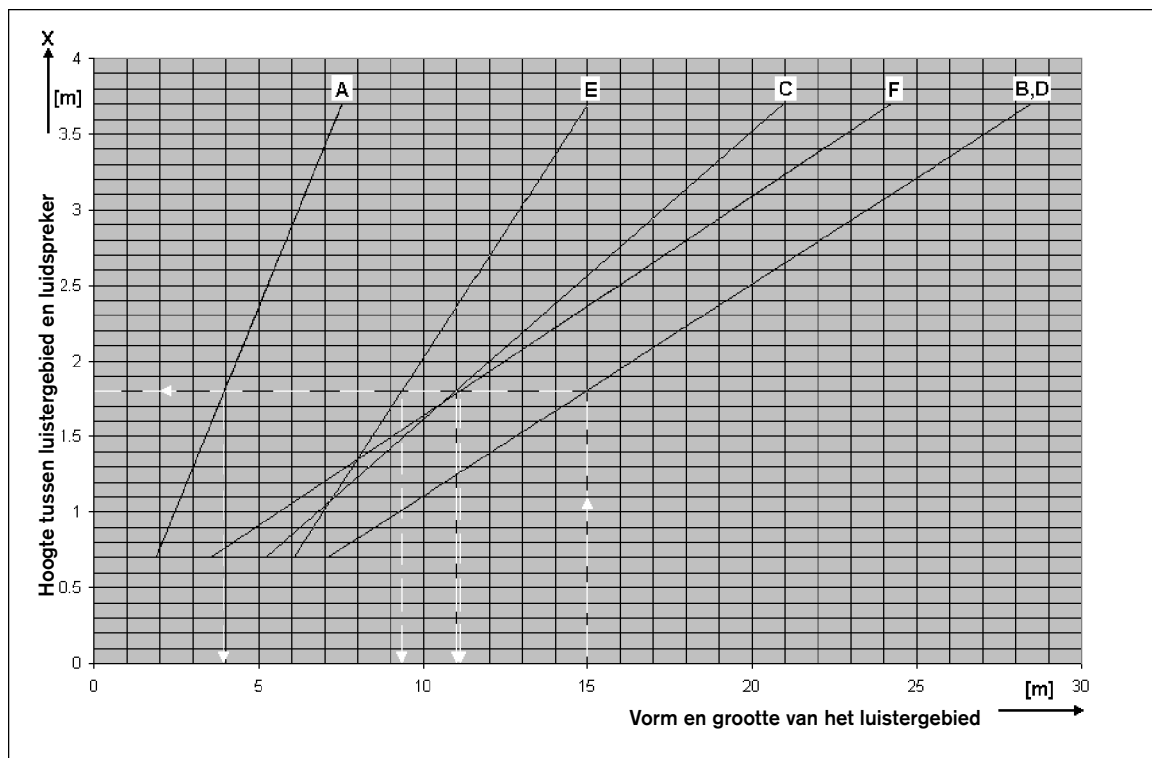

Diagram 1: relatie tussen luistergebied-afstand en bevestigingshoogte van luidsprekersysteem

Betekenis van de diagonale lijnen

B-lijn: maximale afstand van de Line Array luidspreker tot de achterste toehoorder.

D-lijn: luistervlak met halve breedte op 1 kHz

F-lijn: zijlengte luistervlak op 4 kHz

C-lijn: lengte luistervlak

E-lijn: luistervlak met halve breedte op 4 kHz

A-lijn: minimale afstand tot luistervlak

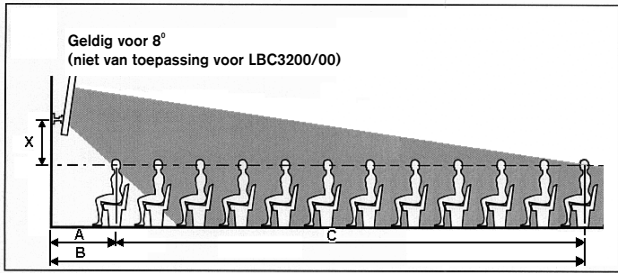

Afbeelding 1: zij aanzicht van uitstraling van Line Array luidspreker en luistervlak

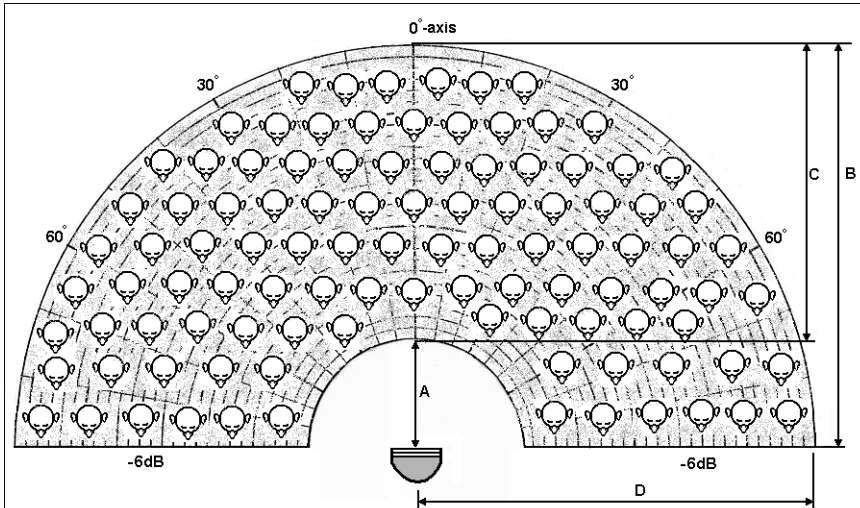

Afbeelding 2: 1 kHz-octafvorm van de Line Array luidspreker

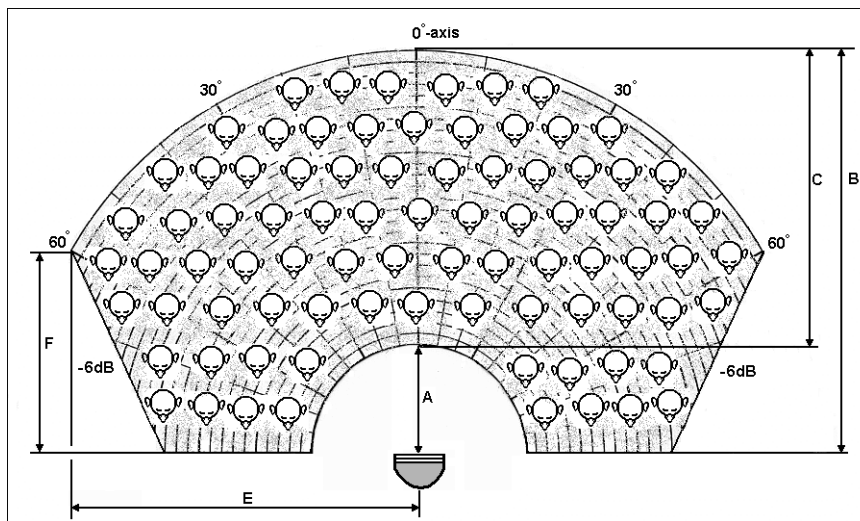

Afbeelding 3: 4 kHz-octafvorm van de Line Array luidspreker

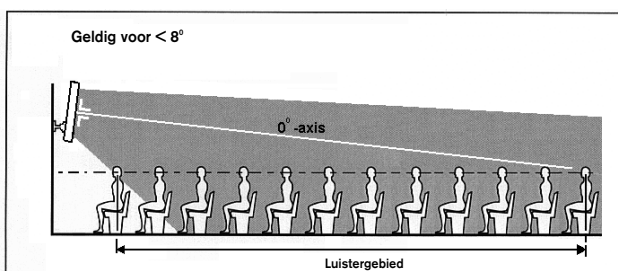

Afbeelding 4: de 0°-as van de Line Array luidspreker op de maximumpositie richten

Luistergebied en bijbehorende bevestigingshoogte voor XLA3210/00

Zo gebruikt u deze bevestigingsmethode:

1. Bepaal de afmetingen van het gewenste 'luistergebied' (een horizontaal vlak op het niveau van de oren van de toehoorders – zie de stippellijn in afbeelding 1).
2. Meet de maximale afstand van de Line Array luidspreker tot de achterste toehoorder in het luistergebied (corresponderend met 'B' in afbeelding 1, 2 en 3).
3. Raadpleeg diagram 1 en ga omhoog van de maximale afstand op de horizontale as. Vanaf het verticale kruispunt met de diagonale B-lijn gaat u horizontaal naar de verticale as. De X-waarde (hoogte van bevestigingsbeugel van Line Array luidspreker boven het luistervlak, 'X' in afbeelding 1) is afgezet langs deze as. De horizontale kruispunten met andere diagonale lijnen geven informatie over de afmetingen van het luistergebied. Deze getallen hebben ook betrekking op afbeelding 2 en 3 (zie ook het onderstaande voorbeeld).
4. Afbeelding 2 toont de 1kHz-octafvorm die wordt uitgestraald door de Line Array luidspreker. Afbeelding 3 toont de uitstraling bij de 4 kHz-octafvorm. Het luistergebied met de optimale akoestische karakteristieken bevindt zich in deze vormen. Controleer of de 4 kHz-vorm met de afmetingen zoals verkregen uit diagram 1, het gewenste luistergebied afdoende dekt.
5. Als het gewenste luistergebied wordt gedekt door de 4kHz-vorm, geeft de X-waarde op de verticale as aan op welke hoogte de Line Array luidspreker moet worden bevestigd boven het luistervlak. Let erop dat de Line Array luidspreker moet worden bevestigd onder een hoek van 8° op de gekozen hoogte!

Nu kunt u de Line Array luidspreker zodanig bevestigen dat de optimale akoestische karakteristieken worden bereikt.

Voorbeeld van gebruik diagram:

De maximale afstand van de Line Array luidspreker tot de achterste toehoorder is 15 m. Als u vanaf het 15 m-punt op de horizontale as van diagram 1 omhoog gaat naar de diagonale B-lijn en daarna zijwaarts naar de verticale as, geven de kruispunten met de andere diagonale lijnen de afmetingen van de luistervlakken aan. In dit voorbeeld geldt:

F-lijn (zijlengte luistervlak van 4 kHz) = 12,2 m
 C-lijn (lengte luistervlak) = 11 m
 E-lijn (luistervlak met halve breedte van 4 kHz) = 8,6 m
 A-lijn (minimale afstand tot luistervlak) = 3,9 m
 Op de verticale as is de X-waarde (de hoogte tussen het luistervlak en de bevestigingsbeugel van de Line Array luidspreker) 1,8 m.

Vragen en antwoorden met betrekking tot de installatie:

- **Het gewenste luistergebied is te groot en past niet in de 4kHz-vorm.**
 Probeer de Line Array luidspreker op een andere hoogte te bevestigen of gebruik meerdere Line Array luidsprekers om een groter luistergebied te bereiken.
- **Waarom een hoek van 8° voor de Line Array luidspreker gebruiken?**
 De uitstralingsvormen zoals weergegeven in afbeelding 2 en 3 met de afmetingen in diagram 1, gelden alleen wanneer de Line Array luidspreker is bevestigd onder een hoek van 8°. Alleen in deze situatie is er sprake van een constant geluidsdrukkniveau en frequentiebereik (constante gevoeligheid) in het luistergebied.
- **Kan ik de Line Array luidspreker onder een andere hoek gebruiken?**
 U kunt de Line Array luidspreker ook onder een andere hoek gebruiken, maar dan worden de optimale akoestische karakteristieken niet bereikt. Er is dan bijvoorbeeld een grotere variatie in het geluidsdrukkniveau hoorbaar in het luistergebied. De waarden in diagram 1 gelden niet voor andere hoeken. Het verdient aanbeveling nooit een grotere hoek dan 8° te gebruiken.
- **De Line Array luidspreker kan niet op de gewenste hoogte worden bevestigd.**
 Als de gewenste hoogte niet haalbaar is vanwege bijvoorbeeld de hoogte van het plafond, gebruikt u een hoek van minder dan 8°. Richt de 0°-as van de Line Array luidspreker op de gewenste maximumpositie (zie afbeelding 4). Let erop dat de tabel in diagram 1 en de vormen in afbeelding 2 en 3 niet gelden voor deze situatie. Controleer in het luistergebied of de spraakverstaanbaarheid acceptabel is, aangezien mededelingen begrijpbaar moeten zijn.

Achtergrondinformatie:

- De vormen zijn gedefinieerd in een echo-loze omgeving. Bij echo-loze omstandigheden is er in deze vormen een maximale variatie in geluidsdruk van 6 dB en is er veel minder variatie in het frequentiebereik waarneembaar. In omgevingen met een normaal of hoog weerkaatsingsniveau is er minder variatie in het geluidsdruk-niveau en is de omvang van de vormen groter. Het waargenomen frequentiebereik in deze vorm is dan nagenoeg constant.
- Wanneer u verder weg gaat dan de maximale positie van het luistergebied (voorbij de maximale afstand van de Line Array luidspreker), neemt alleen het geluidsdruk-niveau af. Er is vrijwel geen variatie in toonhoogte. De afname van het geluidsdruk-niveau hangt sterk af van de weerkaatsing van de ruimte.
- Wanneer u te dicht bij de Line Array luidspreker bent (dichterbij dan de minimale afstand van de Line Array luidspreker), zal al heel snel een afname van de hoge tonen optreden.
- Al naar gelang de mate van weerkaatsing in de ruimte en de geluidschaduw (mensen of voorwerpen voor een

toehoorder die de rechtstreekse geluidsbron blokkeren), kan de spraakverstaanbaarheid op de verste positie gering zijn. In dergelijke situaties is het beter meerdere luidsprekersystemen te gebruiken om het luistergebied op te splitsen.

- De zijlijnen van de vormen in afbeelding 2 en 3 zijn de -6dB punten in relatie tot het geluidsdruk-niveau op de 0°-as.
- Om de beste spraakverstaanbaarheid te bereiken, definieert u een luistergebied waarin de 4kHz-octafvorm het hele gebied afdekt. Om de grenzen van het luistergebied in uw situatie exact te kunnen bepalen, dient u een praktijktest uit te voeren op de locatie waar de Line Array luidspreker wordt geïnstalleerd. Dit is een taak voor een ervaren luisteraar met goedgetrainde oren. Voor deze test stuurt u Pink Noise door de Line Array luidspreker. Het is beter om de lagere tonen voor deze test terug te draaien, aangezien deze niet bijdragen tot de spraakverstaanbaarheid. Loop rond in het luistergebied en luister naar de hoge tonen. De plaatsen waar de hoge tonen snel afnemen, zijn de grenzen van het luistergebied.

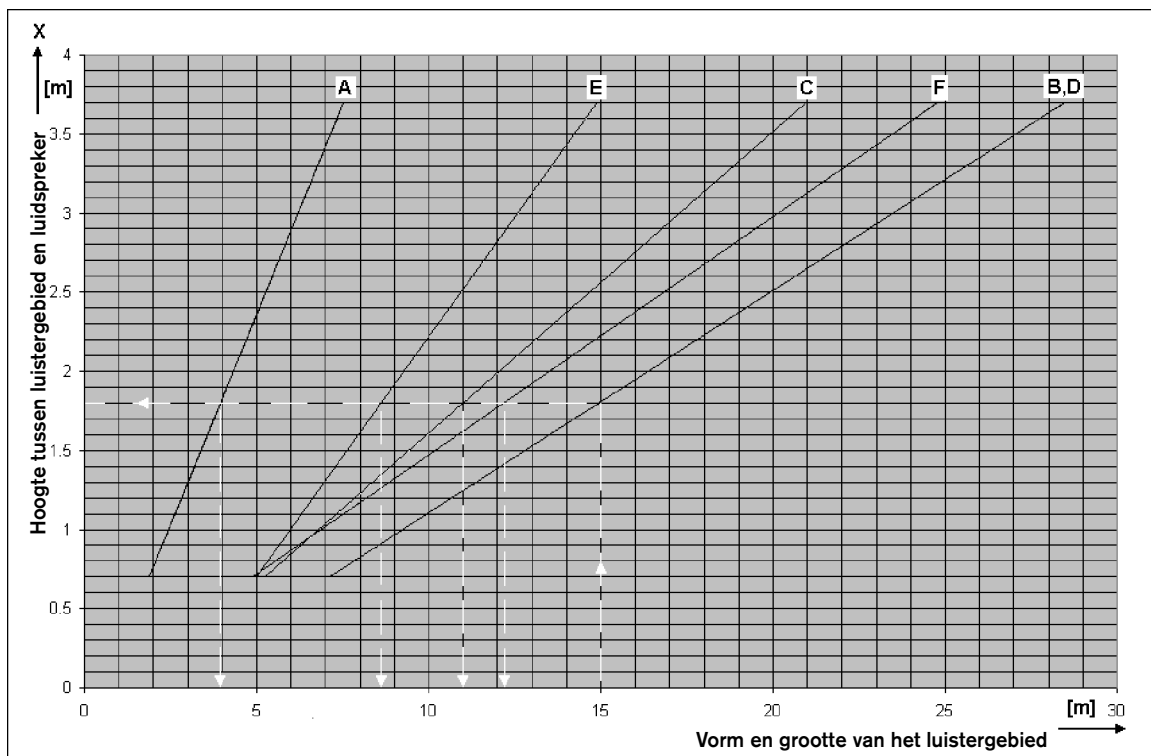

Diagram 1: relatie tussen luistergebied-afstand en bevestigingshoogte van luidsprekersysteem

Betekenis van de lijnen

B-lijn: maximale afstand van de Line Array luidspreker tot de achterste toehoorder.

D-lijn: luistervlak met halve breedte op 1 kHz

F-lijn: zijlengte luistervlak op 4 kHz

C-lijn: lengte luistervlak

E-lijn: luistervlak met halve breedte op 4 kHz

A-lijn: minimale afstand tot luistervlak

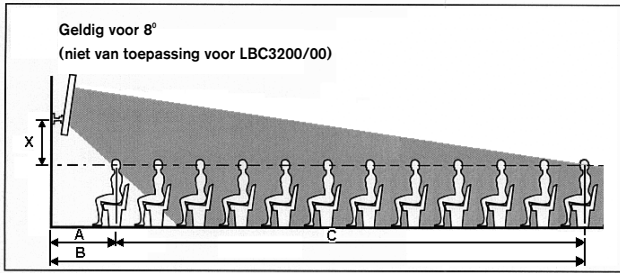

Afbeelding 1: zijanzicht van uitstraling van Line Array luidspreker en luistervlak

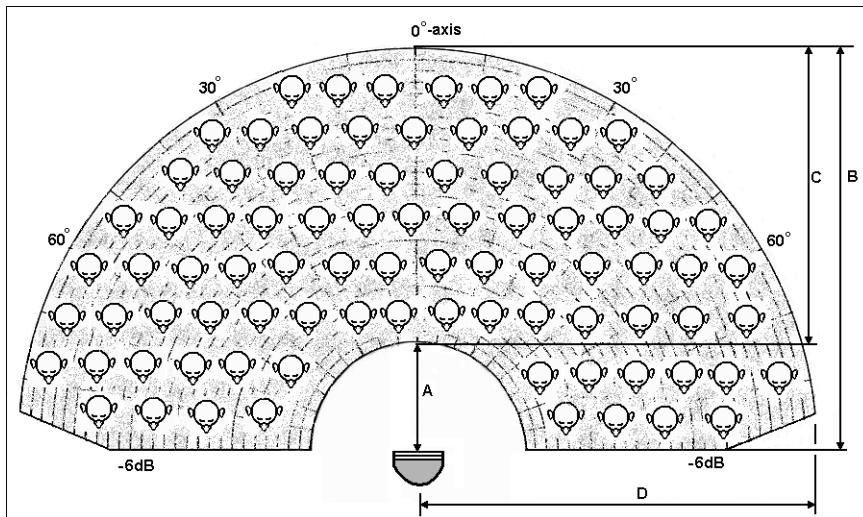

Afbeelding 2: 1 kHz-octafvorm van de Line Array luidspreker

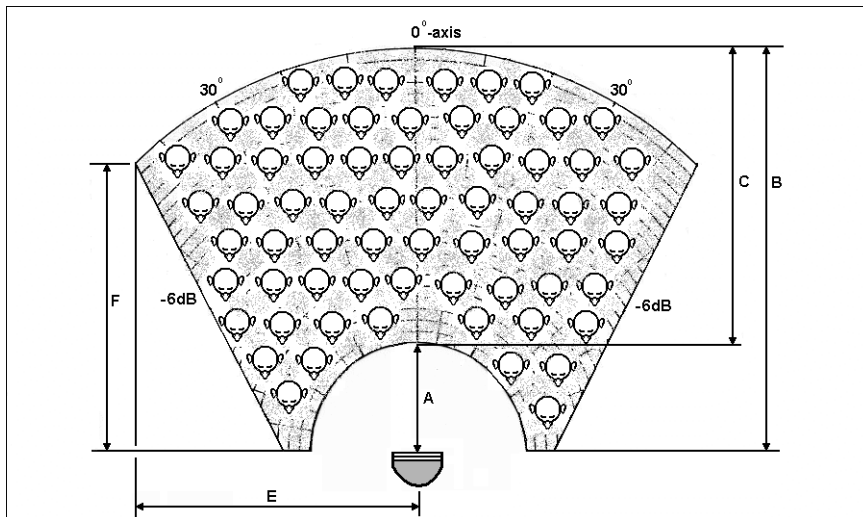

Afbeelding 3: 4 kHz-octafvorm van de Line Array luidspreker

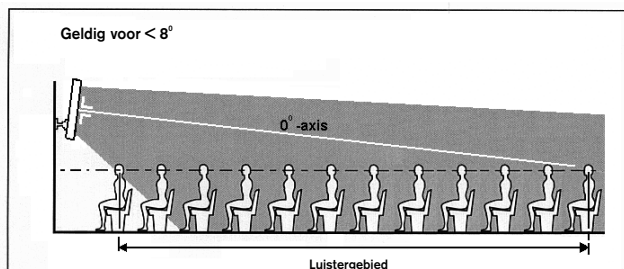

Afbeelding 4: de 0°-as van de Line Array luidspreker op de maximumpositie richten

TECHNISCHE GEGEVENS**LBC 3200/00**

Maximaal vermogen	45 W
Nominaal vermogen	30 W (30-15-7,5 W)
Geluidsdrukniveau	
bij 30 W/1 W (1 kHz, 1 m)	106 dB/91 dB (SPL)
Effectief frequentiebereik (-10 dB)	190 Hz tot 18 kHz
Openingshoek	
(op 1 kHz/4 kHz, -6 dB)	
Horizontaal	220°/130°
Verticaal	70°/18°
Nominale ingangsspanning	100 V
Nominale impedantie	333 Ohm
Omgevingstemperatuur: tussen	-25 en +55 °C
Veiligheid	conform EN 60065
Aansluiting	klemmenblokje
Afmetingen (H x B x D)	600 x 80 x 90 mm
Kleur	zilver
Gewicht	3 kg

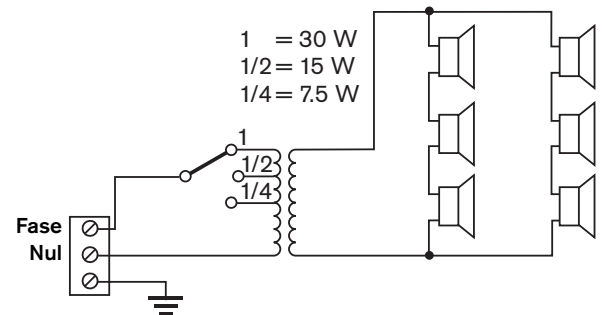
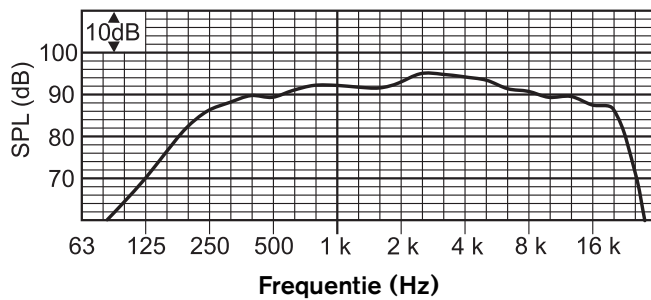
**LBC 3200/00**

Octaafband (Hz)	250	500	1 k	2 k	4 k	8 k
SPL 1.1	87	89	91	93	93	89
SPL max.	102	104	106	108	108	104
Q-factor	1,3	2,2	4,5	11,6	25,7	58,9
Hor. hoek (graden)	360	360	220	190	130	100
Vert. hoek (graden)	360	120	70	32	18	10

Horizontaal

Verticaal

LBC 3200/00
250 Hz horizontaal

LBC 3200/00
250 Hz verticaal

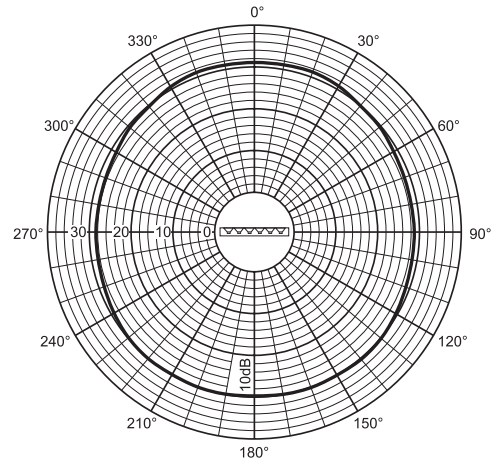
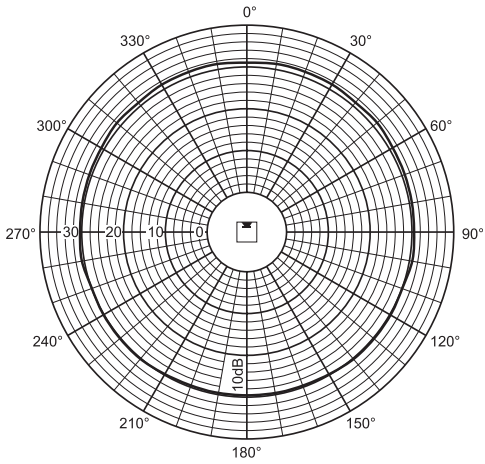

LBC 3200/00
500 Hz horizontaal

LBC 3200/00
500 Hz verticaal

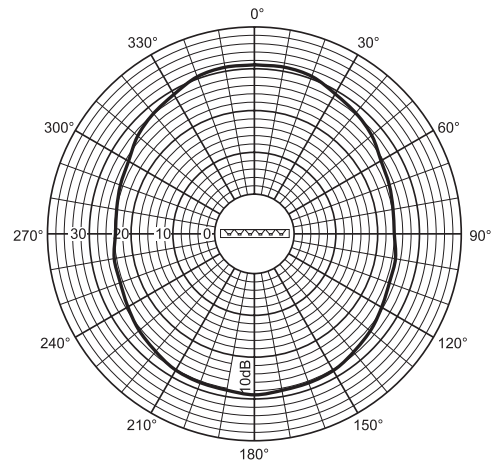
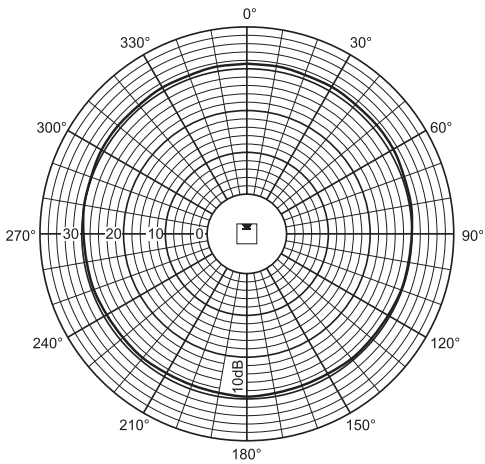

LBC 3200/00
1 kHz horizontaal

LBC 3200/00
1 kHz verticaal

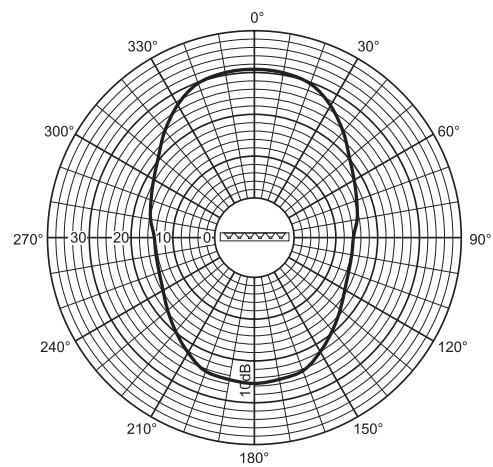
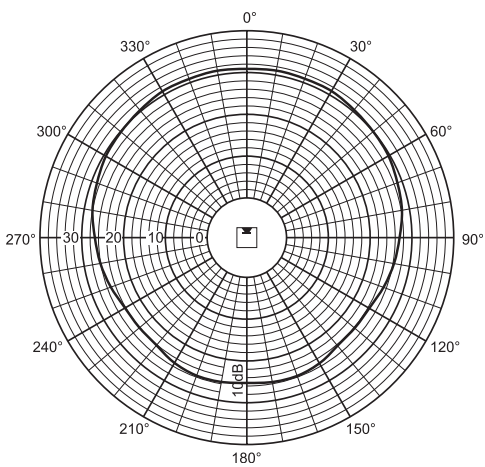

Horizontaal

Verticaal

LBC 3200/00
2 kHz horizontaal

LBC 3200/00
2 kHz verticaal

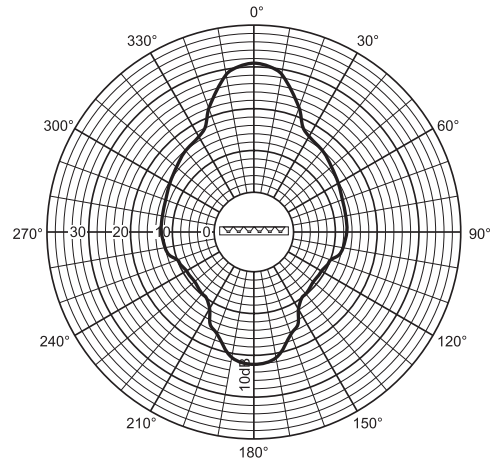
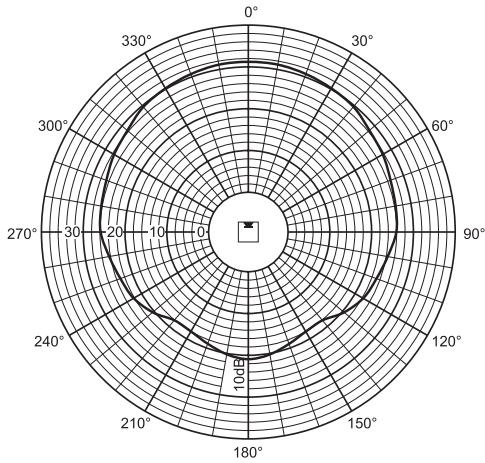

LBC 3200/00
4 kHz horizontaal

LBC 3200/00
4 kHz verticaal

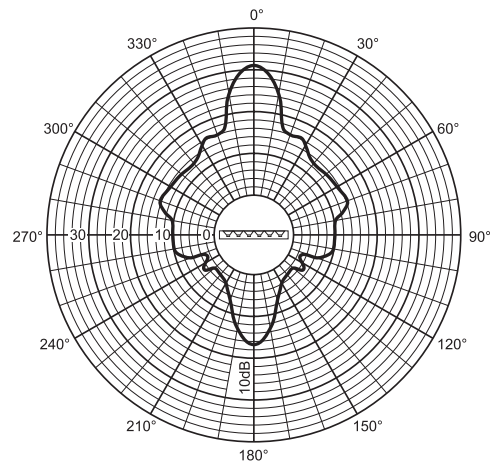
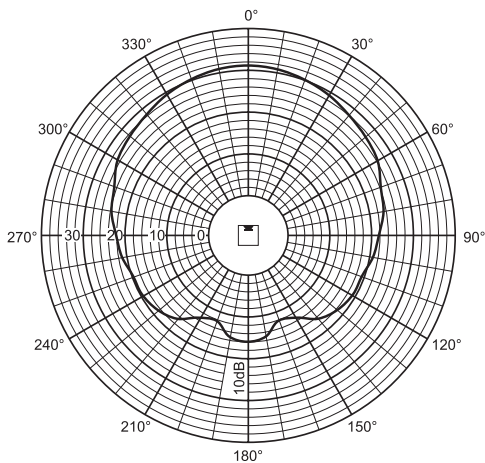

LBC 3200/00
8 kHz horizontaal

LBC 3200/00
8 kHz verticaal

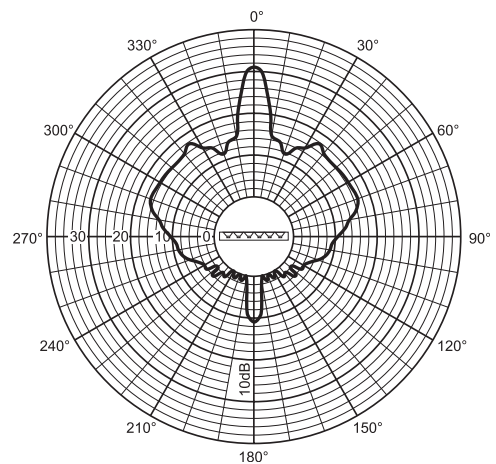
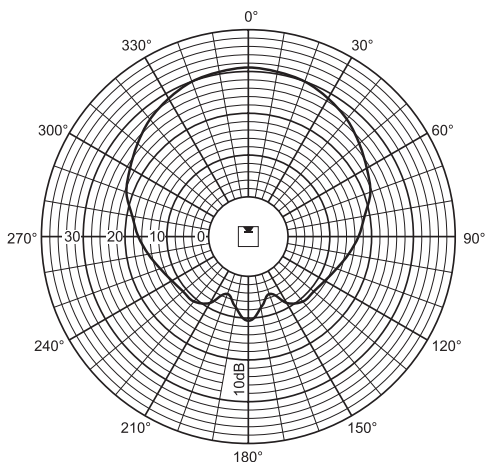

TECHNISCHE GEGEVENS

LBC 3201/00

Maximaal vermogen	90 W
Nominaal vermogen	60 W (60-30-15 W)
Geluidsdrukniveau	
bij 60 W/1 W (1 kHz, 1 m)	110 dB/92 dB (SPL)
Effectief frequentiebereik (-10 dB)	190 Hz tot 18 kHz
Openingshoek	
(1 kHz / 4 kHz, -6 dB)	
Horizontaal	210°/132°
Verticaal	50°/22°
Nominale ingangsspanning	100 V
Nominale impedantie	167 Ohm
Omgevingstemperatuur: tussen	-25 en +55 °C
Veiligheid	conform EN 60065
Aansluiting	klemmenblokje
Afmetingen (H x B x D)	1200 x 80 x 90 mm
Kleur	zilver
Gewicht	6,4 kg

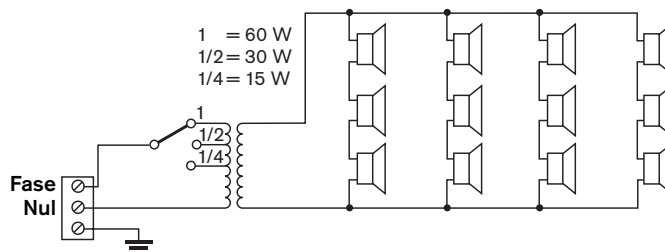
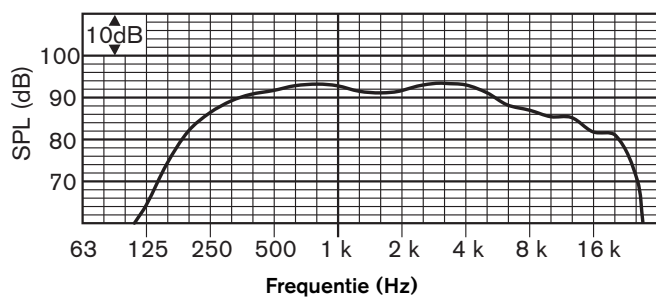

LBC 3201/00

Octaafband (Hz)	250	500	1 k	2 k	4 k	8 k
SPL 1.1	88	92	92	91	91	86
SPL max.	106	110	110	109	109	104
Q-factor	2,2	3,2	6,5	12,6	23,4	53,3
Hor. hoek (graden)	360	360	210	192	132	100
Vert. hoek (graden)	107	67	50	33	22	12

Horizontaal

Verticaal

LBC 3201/00
250 Hz horizontaal

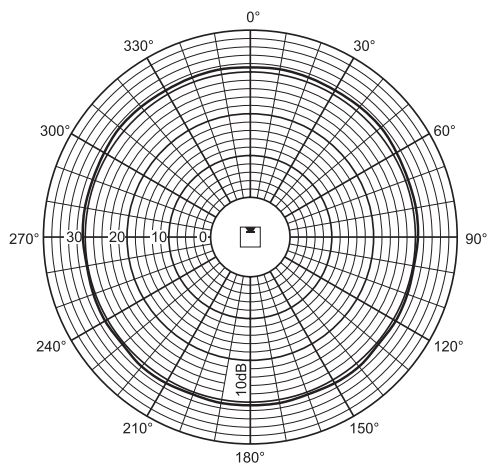

LBC 3201/00
250 Hz verticaal

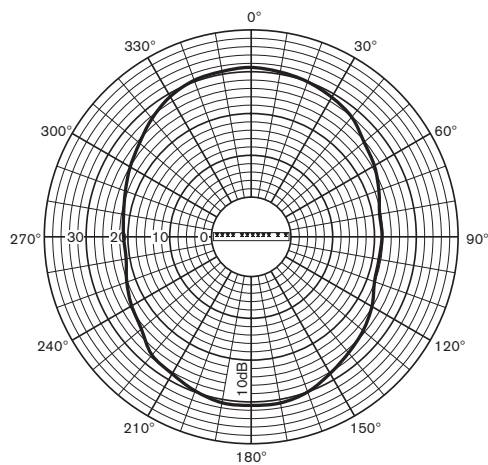

LBC 3201/00
500 Hz horizontaal

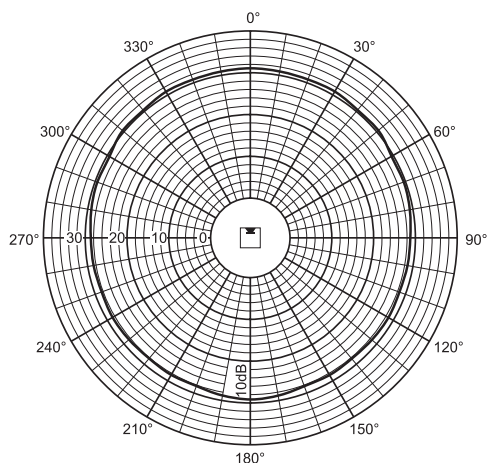

LBC 3201/00
500 Hz verticaal

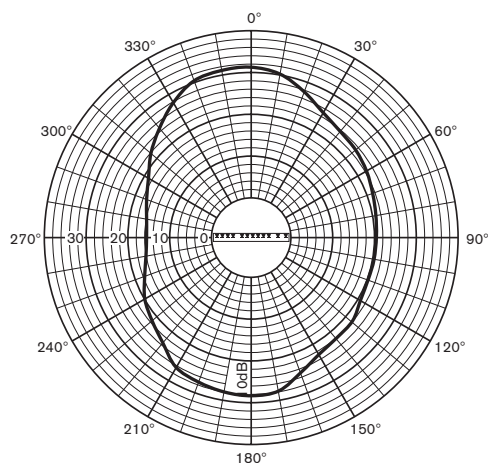

LBC 3201/00
1 kHz horizontaal

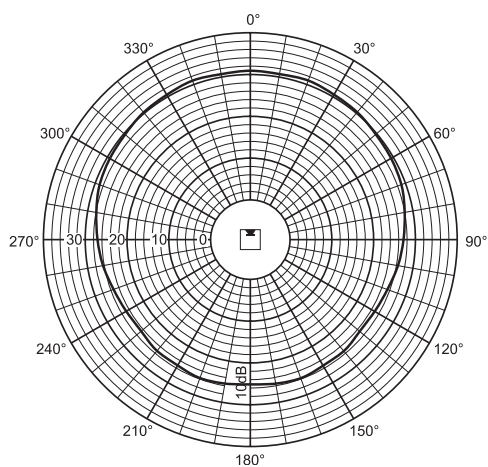

LBC 3201/00
1 kHz verticaal

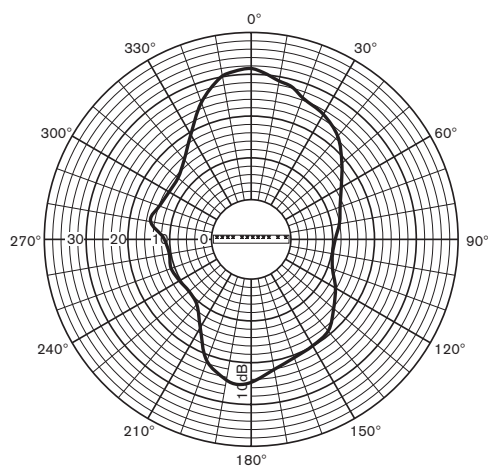

Horizontaal

Verticaal

LBC 3201/00
2 kHz horizontaal

LBC 3201/00
2 kHz verticaal

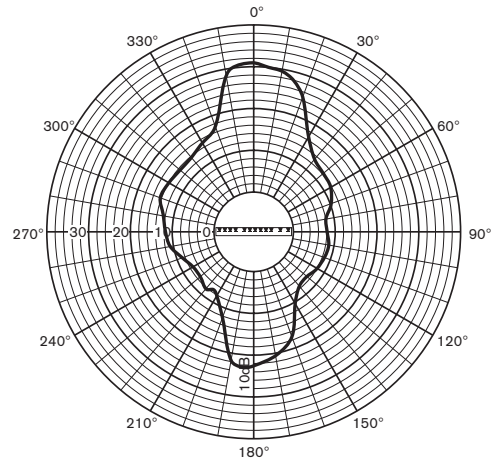
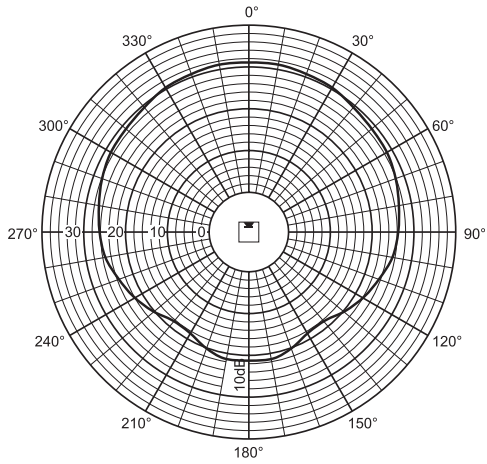

LBC 3201/00
4 kHz horizontaal

LBC 3201/00
4 kHz verticaal

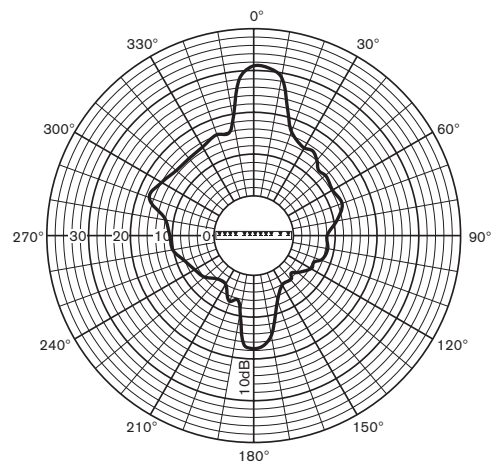
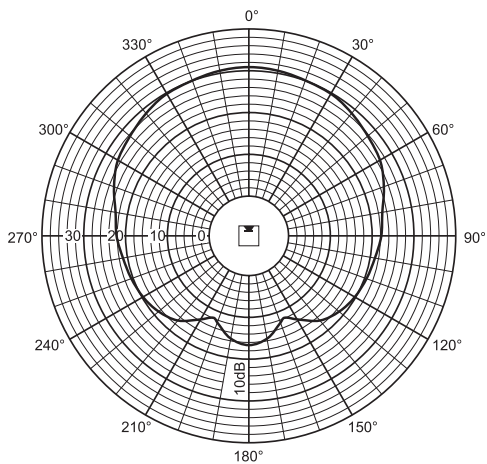

LBC 3201/00
8 kHz horizontaal

LBC 3201/00
8 kHz verticaal

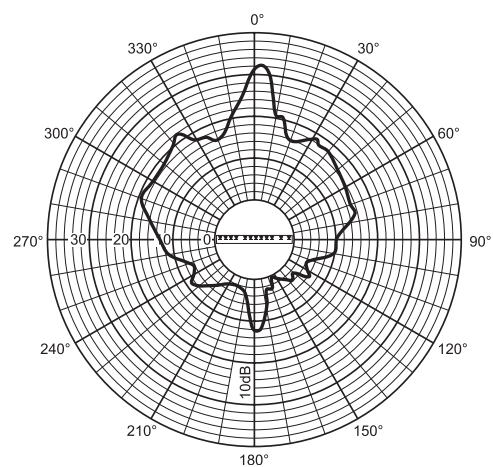
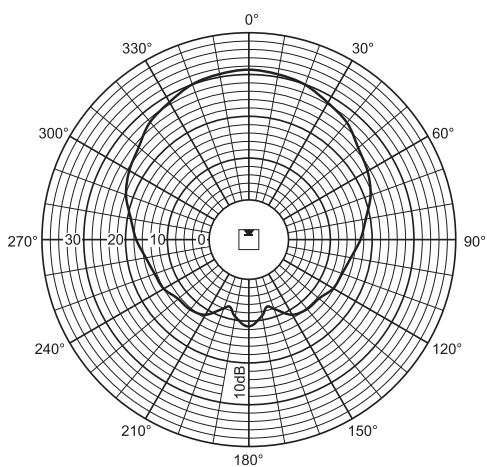

TECHNISCHE GEGEVENS**LBC 3210/00**

Maximaal vermogen	90 W
Nominaal vermogen	60 W (60-30-15 W)

Geluidsdrukniveau

bij 60 W/1 W (1 kHz, 1 m) 115 dB/97 dB (SPL)

Effectief frequentiebereik (-10 dB) 190 Hz tot 20 kHz

Openingshoek

(1 kHz / 4 kHz, -6 dB)

Horizontaal	170°/90°
Verticaal	55°/18°

Nominale ingangsspanning 100 V

Nominale impedantie 167 Ohm

Omgevingstemperatuur: tussen -25 en +55 °C

Veiligheid conform EN 60065

Bescherming tegen water/stof IP 66 conform IEC 60529

Aansluiting klemmenblokje

Afmetingen (H x B x D) 1200 x 160 x 90 mm

Kleur zilver

Gewicht 9 kg

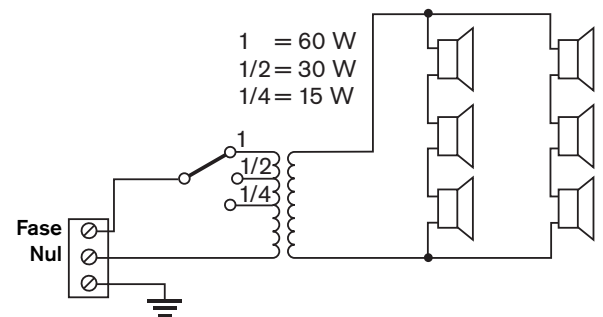
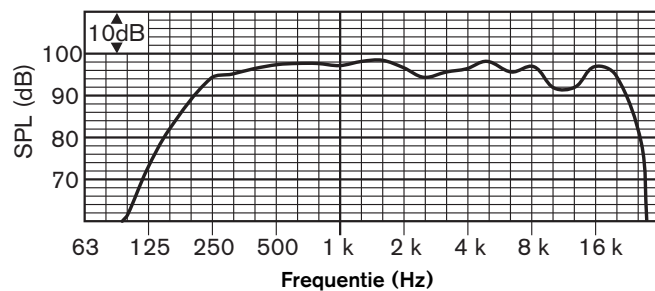
**LBC 3210/00**

Octaafband (Hz)	250	500	1 k	2 k	4 k	8 k
SPL 1.1	94	97	97	95	96	93
SPL max.	112	115	115	113	114	111
Q-factor	2,2	2,7	6,3	10,8	22,6	32,3
Hor. hoek (graden)	360	180	170	160	90	60
Vert. hoek (graden)	100	60	55	34	18	10

Horizontaal

Verticaal

LBC 3210/00
250 Hz horizontaal

LBC 3210/00
250 Hz verticaal

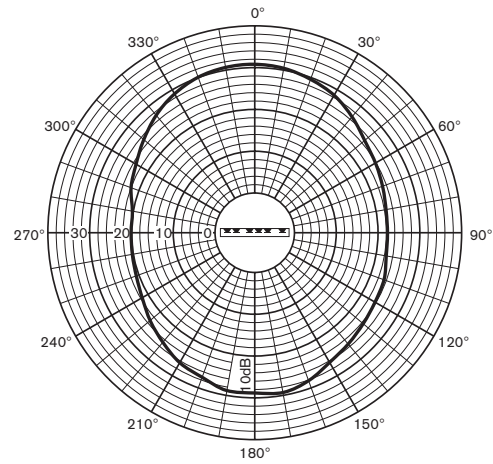
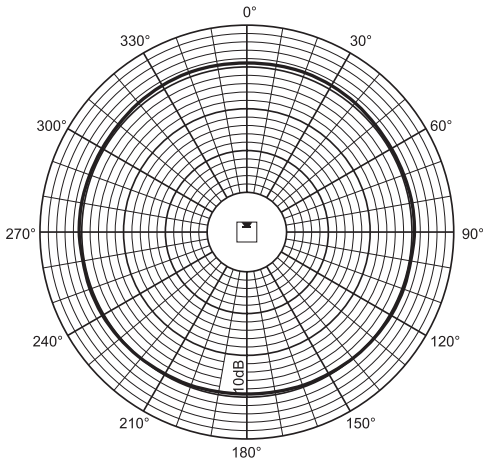

LBC 3210/00
500 Hz horizontaal

LBC 3210/00
500 Hz verticaal

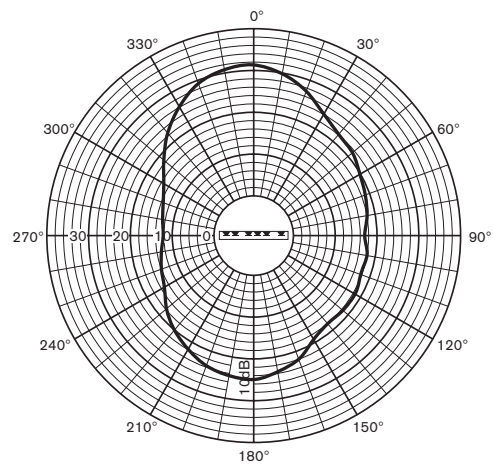
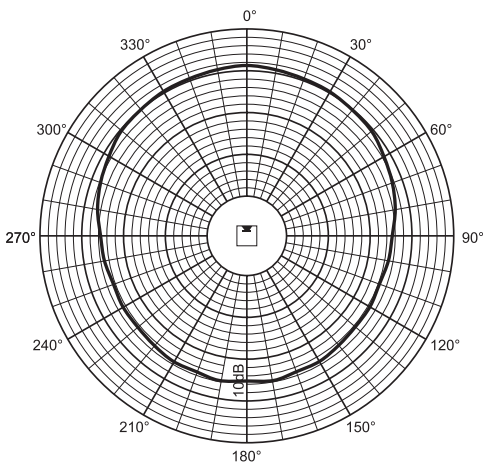

LBC 3210/00
1 kHz horizontaal

LBC 3210/00
1 kHz verticaal

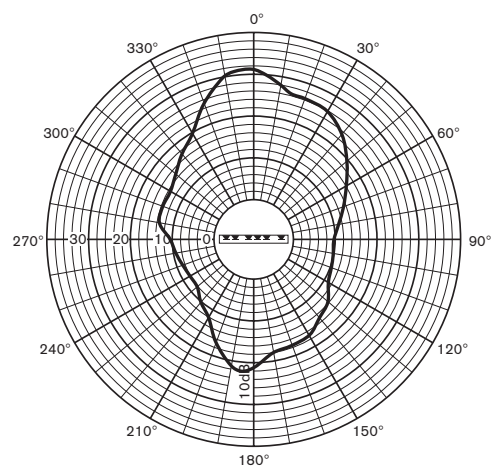
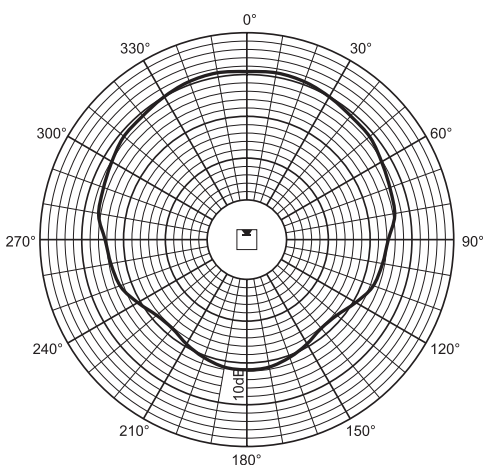

Horizontaal

Verticaal

LBC 3210/00
2 kHz horizontaal

LBC 3210/00
2 kHz verticaal

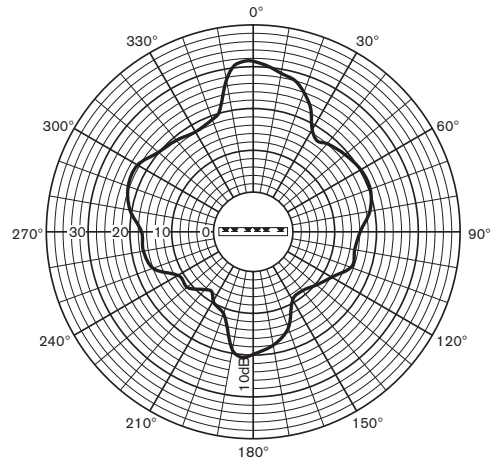
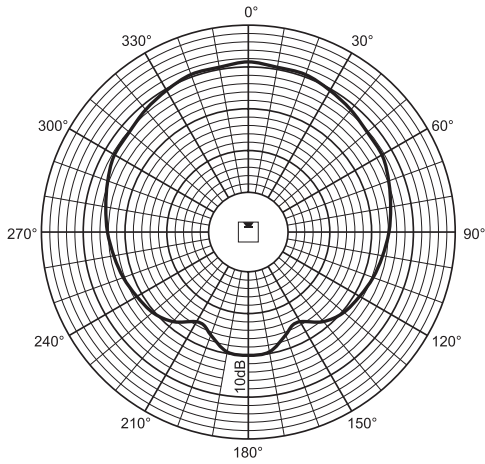

LBC 3210/00
4 kHz horizontaal

LBC 3210/00
4 kHz verticaal

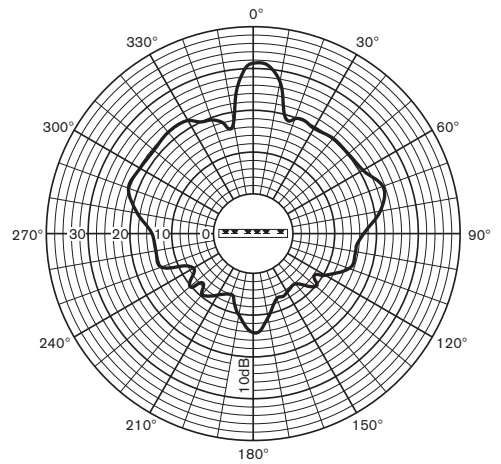
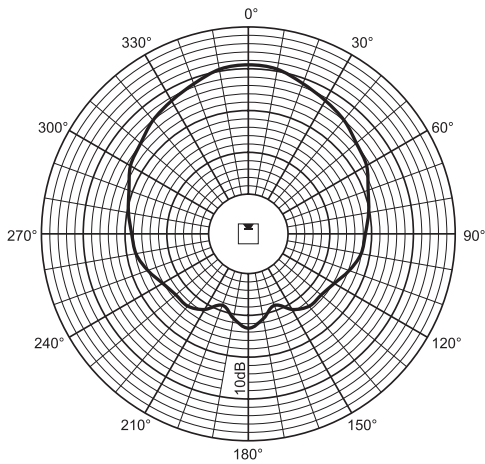

LBC 3210/00
8 kHz horizontaal

LBC 3210/00
8 kHz verticaal

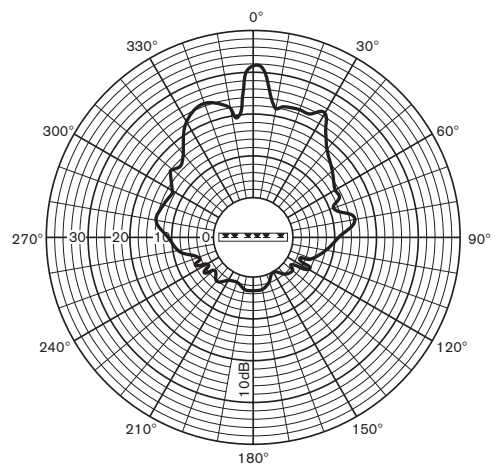
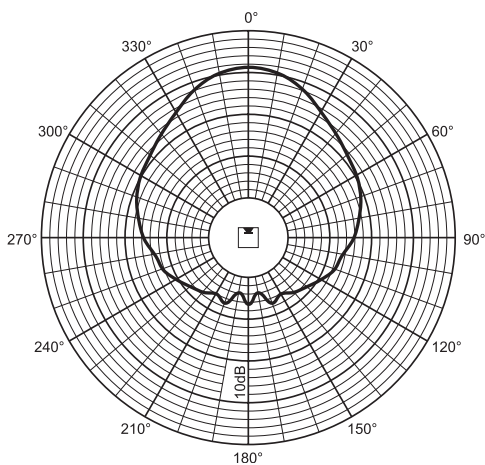

www.boschsecuritysystems.nl

BOSCH

Indice	Pagina
Guida all'installazione (figg. 1-17)	116
Montaggio scheda di controllo line/altoparlanti (opzionale) (figg. A1-A5)	118
Montaggio staffa aggiuntiva (opzionale) (figg. B1-B5)	118
Montaggio piantana (opzionale) (figg. C1-C3)	118
Area di ascolto e relativa altezza di montaggio per il modello LBC 3200/00	119
Area di ascolto e relativa altezza di montaggio per il modello LBC 3201/00	121
Area di ascolto e relativa altezza di montaggio per il modello LBC 3210/00	124
Dati tecnici del modello LBC 3200/00	127
Dati tecnici del modello LBC 3201/00	130
Dati tecnici del modello LBC 3210/00	123

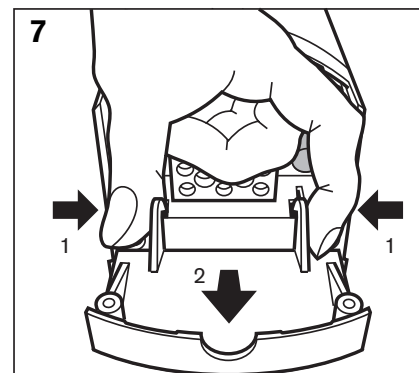
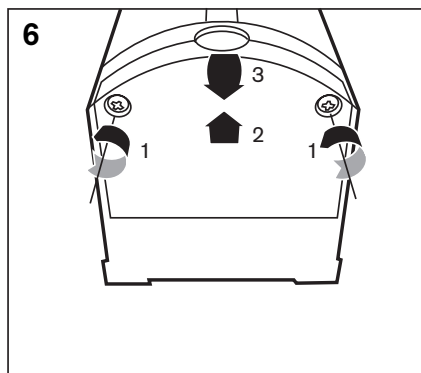
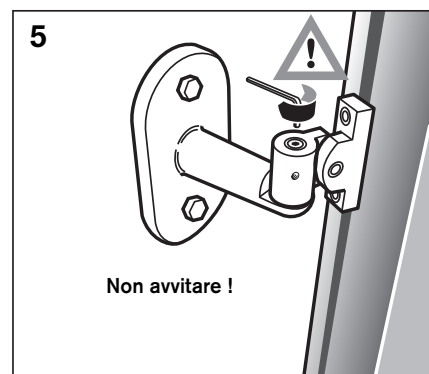
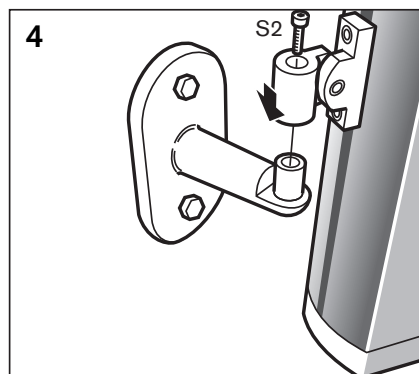
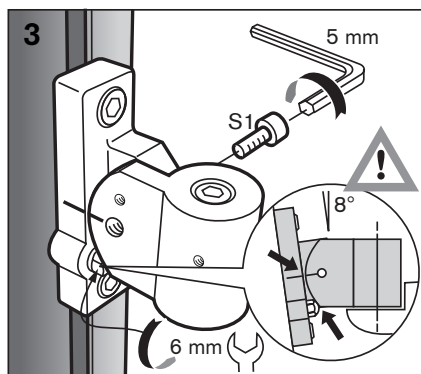
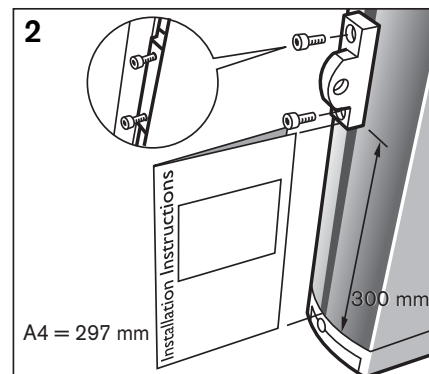
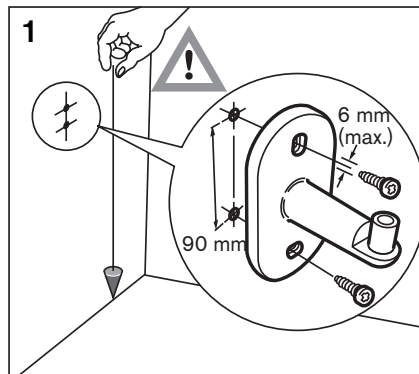
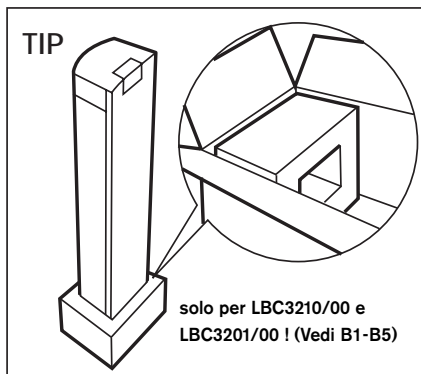
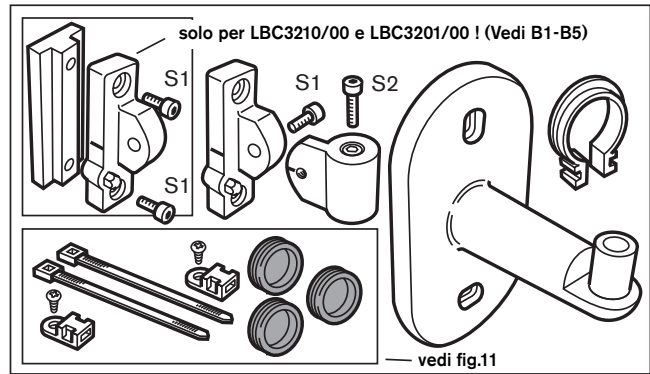
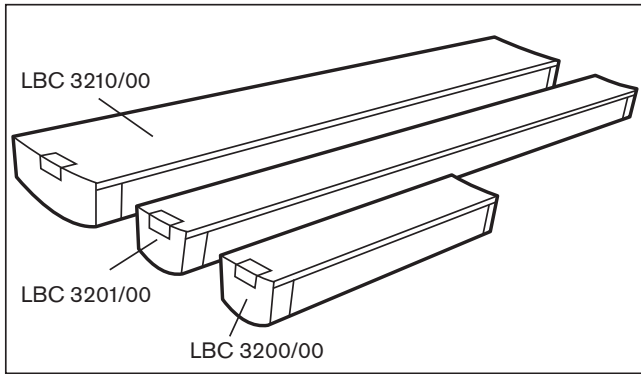

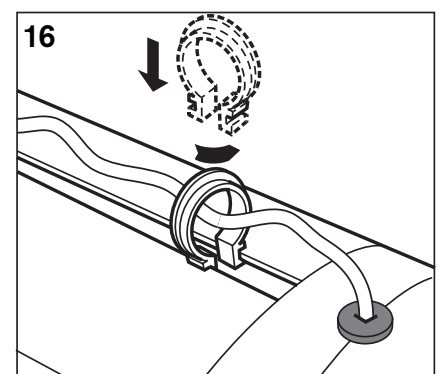
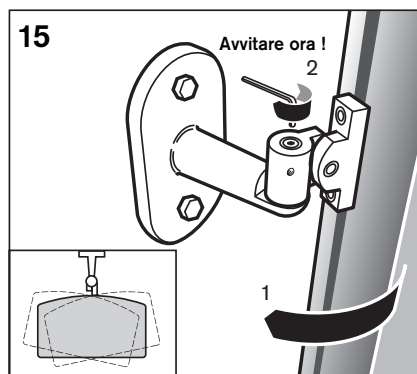
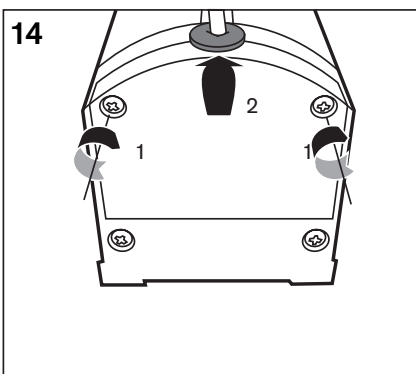
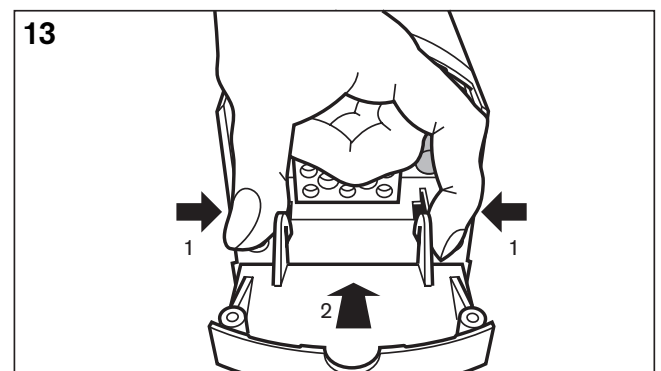
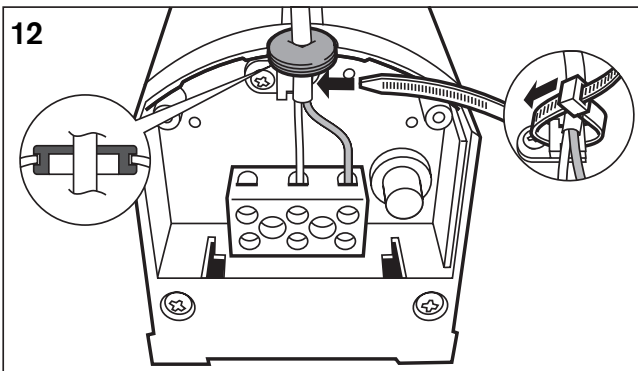
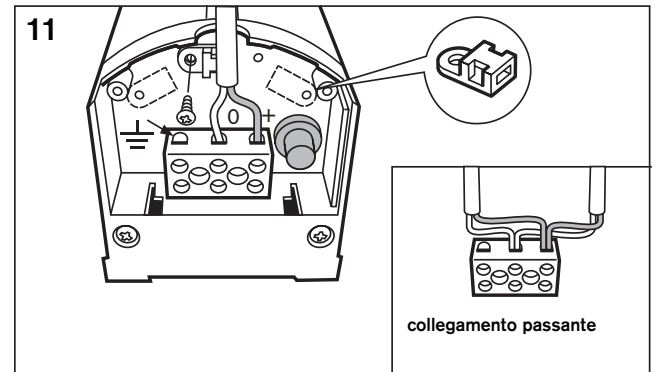
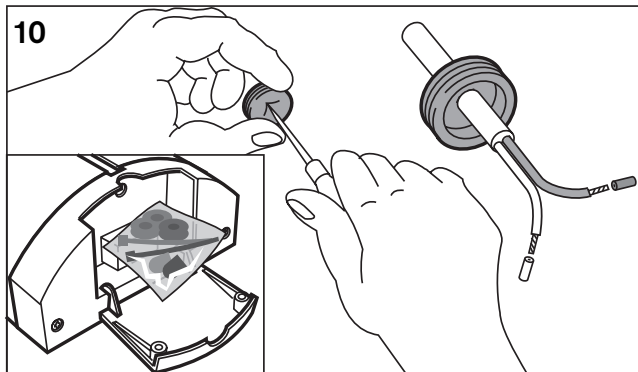
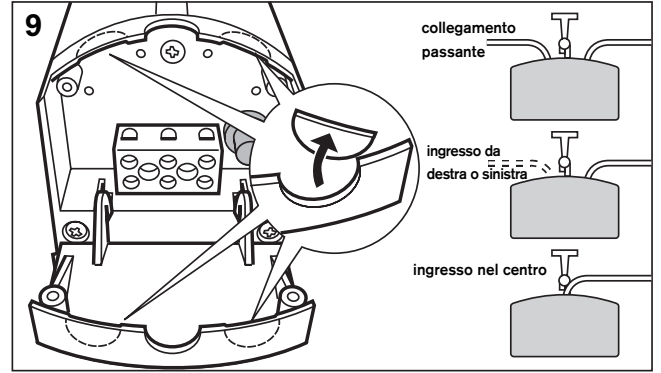
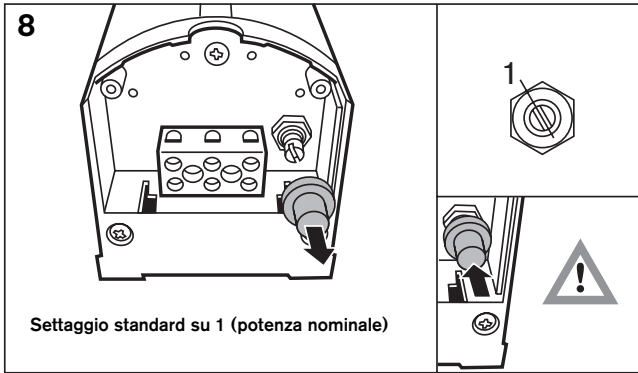

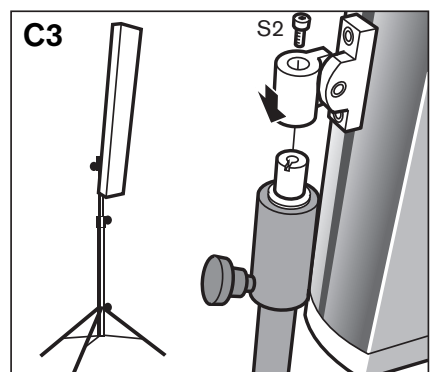
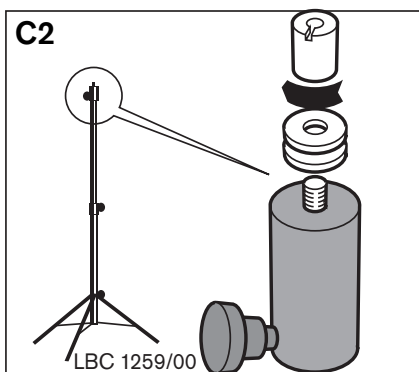
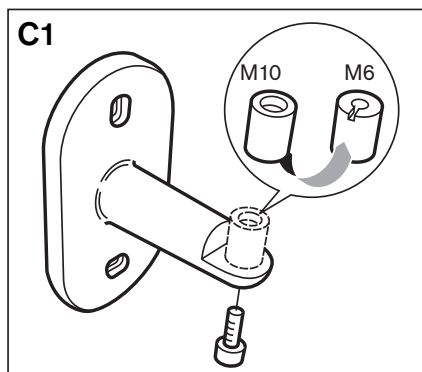
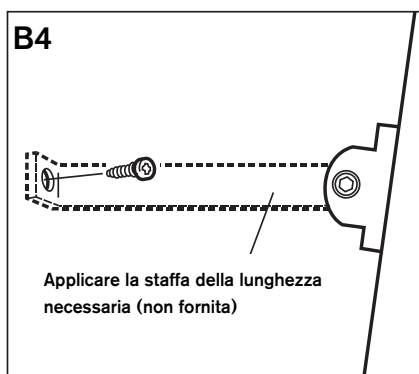
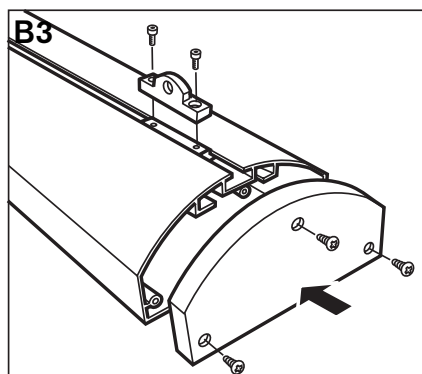
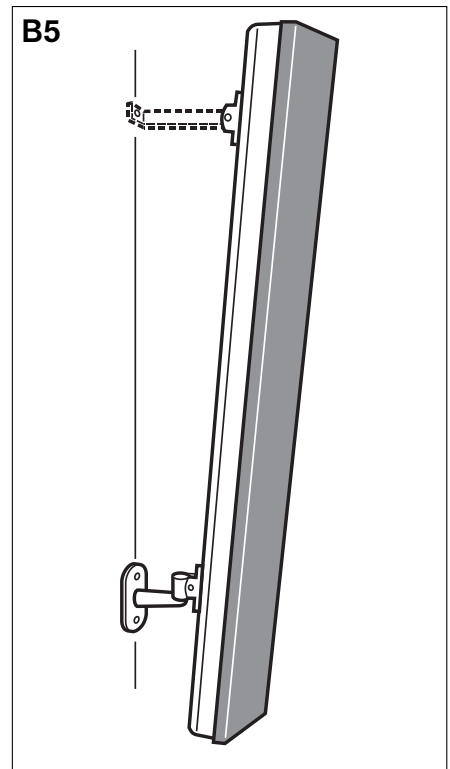
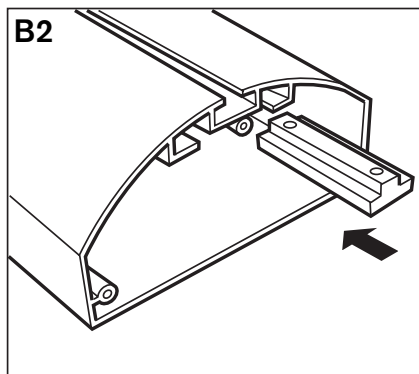
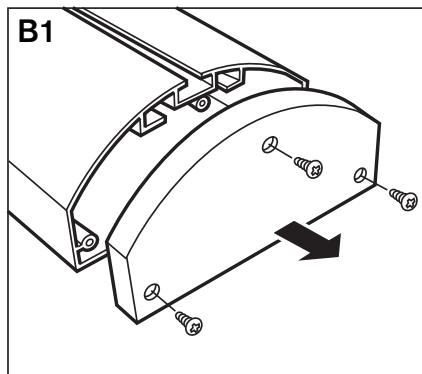
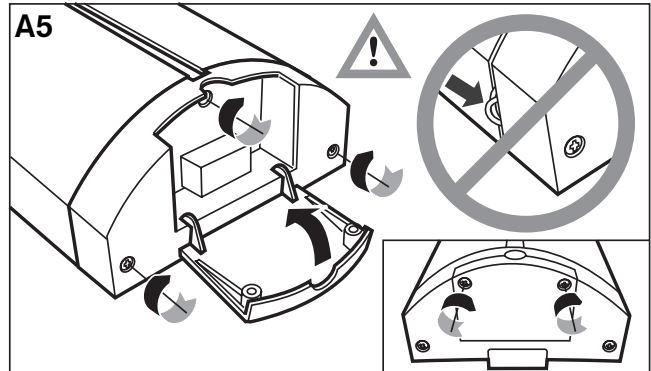
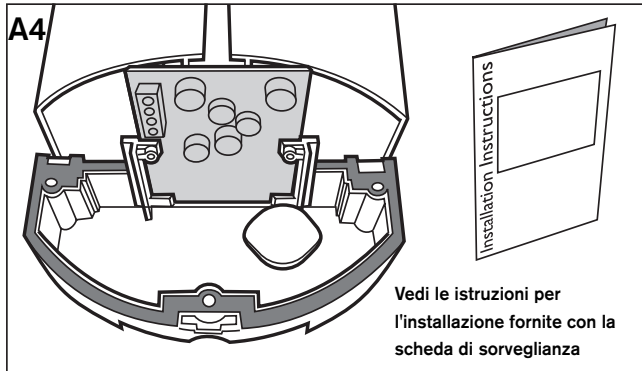
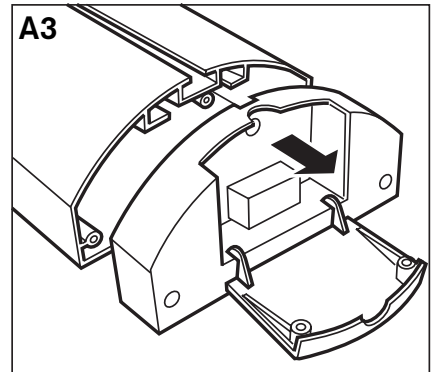
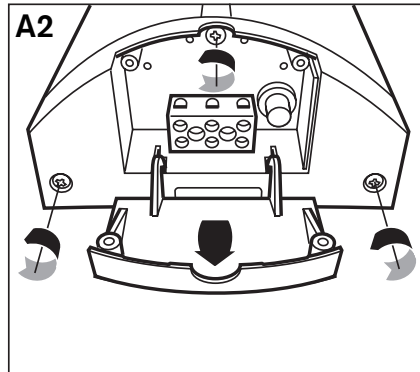
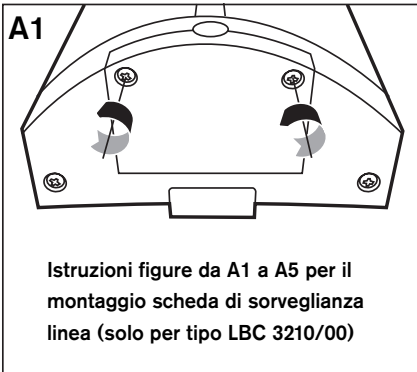

Area di ascolto e relativa altezza di montaggio per il modello XLA3200/00

Metodo per stabilire l'altezza di montaggio e l'inclinazione per gli altoparlanti LBC3200/00

1. Determinare le dimensioni dell'"area di ascolto" desiderata, ovvero del piano orizzontale all'altezza delle orecchie degli ascoltatori (vedere la linea tratteggiata in figura 1).
2. Determinare l'inclinazione di montaggio degli altoparlanti. Gli altoparlanti sono ideati per diffondere il suono sopra la testa degli ascoltatori; si consiglia pertanto un'inclinazione massima di 6°. È possibile scegliere tra diverse possibilità, ognuna delle quali presenta determinati vantaggi e svantaggi.
 - **Opzione 1: Massimizzare l'area di ascolto**
Se si desidera un'area di ascolto di grandi dimensioni, scegliere un'inclinazione di circa 3° (vedere figura 1). Tenere presente che, allontanandosi dagli altoparlanti, il livello di pressione sonora diminuisce in base al riverbero ambientale presente. Per sentire i toni alti con chiarezza, l'ascoltatore deve essere in grado di vedere gli altoparlanti.
 - **Opzione 2: Ridurre al minimo la variazione del livello di pressione sonora**
Se si desidera una minore variazione del livello di pressione sonora, scegliere un'inclinazione di 5°. Tenere presente che in questo modo l'area di ascolto totale è inferiore a quella ottenuta con la prima opzione e che l'area contigua agli altoparlanti ("A" in figura 2) non fa parte dell'area di ascolto. Il grafico 1 mostra la relazione tra "A" e l'altezza di montaggio degli altoparlanti montati con un'inclinazione di 5°.
3. Una volta scelto l'angolo di inclinazione appropriato, è possibile determinare l'altezza di montaggio dell'altoparlante regolando l'asse corrispondente a 0° (l'asse centrale dell'area di ascolto) in corrispondenza della posizione desiderata appena sopra il livello delle orecchie dell'ascoltatore più lontano. È possibile eseguire tale operazione variando l'altezza di montaggio dell'altoparlante sulla parete.

È ora possibile installare gli altoparlanti in modo da ottenere prestazioni acustiche ottimali.

Domande e risposte sull'installazione

- **L'installazione degli altoparlanti LBC3200/00 è analoga a quella dei modelli LBC3201/00 o LBC3210/00?**

Gli altoparlanti sono ideati per l'uso in ambienti di piccole e medie dimensioni. È possibile ottenere prestazioni acustiche ottimali orientando il suono appena sopra la testa degli ascoltatori. Se gli altoparlanti sono montati seguendo la procedura di installazione del modello LBC3201/00 oppure

LBC3210/00, l'area di ascolto risulterà assai limitata. Per lo stesso motivo, non è opportuno scegliere un'inclinazione superiore a 6°.

- **Se l'ascoltatore non è in grado di vedere gli altoparlanti, riuscirà comunque a percepire i toni alti?**
I toni alti possono essere paragonati alla luce. Quando un ostacolo si frappone tra il soggetto e la sorgente luminosa, quest'ultima non viene percepita con la dovuta intensità poiché si crea una zona d'ombra. La stessa situazione si verifica con i toni alti. Quando tra l'ascoltatore e l'altoparlante sono presenti più persone, l'ascoltatore si trova nella zona d'ombra del suono e percepisce i toni alti con minore intensità.

Informazioni generali

- A causa delle diverse inclinazioni possibili, è difficile stabilire con precisione la forma del suono diffuso dagli altoparlanti.
- Con un'inclinazione ridotta degli altoparlanti si ottiene un'area di ascolto di notevoli dimensioni. A seconda del riverbero ambientale e della zona d'ombra del suono (soggetti o oggetti situati davanti a un ascoltatore che ostacolano la sorgente sonora), la qualità acustica potrebbe diminuire se l'ascoltatore si trova lontano dagli altoparlanti. In questi casi, è consigliabile utilizzare più altoparlanti per suddividere l'area di ascolto.
- Quando ci si allontana oltre l'area di ascolto (superando quindi la distanza massima dall'altoparlante), diminuisce solo il livello di pressione sonora e la variazione nell'altezza dei toni è trascurabile. La diminuzione del livello di pressione sonora varia in base al riverbero ambientale presente.
- Se la distanza dagli altoparlanti è inferiore alla distanza minima consentita e l'angolo di inclinazione è di 5°, si verifica immediatamente una diminuzione dei toni alti.
- Poiché gli altoparlanti sono ideati per diffondere il suono sopra la testa degli ascoltatori, si consiglia di non montare gli altoparlanti ad un'altezza eccessiva rispetto all'area di ascolto.
- Per stabilire con esattezza i limiti dell'area di ascolto, è necessario eseguire un test pratico nel punto di installazione degli altoparlanti. Tale procedura deve essere effettuata da un ascoltatore esperto. Per eseguire tale operazione, riprodurre una traccia con rumore rosa attraverso gli altoparlanti. Si consiglia di ridurre i toni bassi poiché riducono la qualità acustica. Ascoltare i toni alti in diversi punti dell'area di ascolto. Le zone in cui i toni alti diminuiscono rapidamente delimitano l'area di ascolto.



Figura 1 - Vista laterale della radiazione acustica montato a muro con inclinazione ridotta



Figura 2 - Vista laterale della radiazione acustica montato a muro con inclinazione di 5°

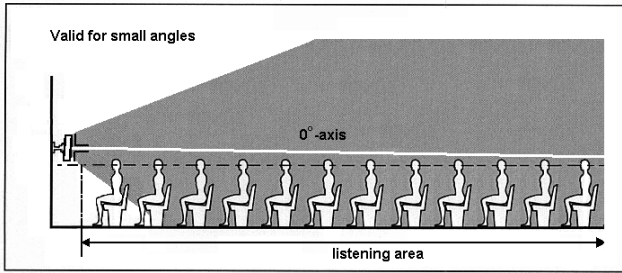

Grafico 1 - Relazione tra la distanza dell'area di ascolto e l'altoparlante

Area di ascolto e relativa altezza di montaggio per il modello XLA3201/00

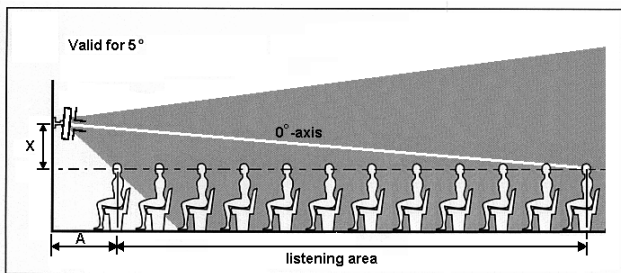
Istruzioni per il montaggio:

1. Determinare le dimensioni dell'"area di ascolto" desiderata, ovvero del piano orizzontale all'altezza delle orecchie degli ascoltatori (vedere la linea tratteggiata in figura 1).
2. Misurare la distanza massima tra gli altoparlanti e l'ascoltatore più lontano nell'area di ascolto (corrispondente al punto "B" nelle figure 1, 2 e 3).
3. Facendo riferimento al grafico 1, tracciare una linea verticale in corrispondenza del punto di massima distanza sull'asse delle ascisse. Dal punto di intersezione verticale con la linea B diagonale, tracciare una linea orizzontale fino a incontrare l'asse delle ordinate. Il valore X, riferito all'altezza della staffa di montaggio degli altoparlanti dal piano di ascolto, ('X' in figura 1), si trova sull'asse delle ascisse. Le intersezioni orizzontali con le altre linee diagonali indicano le dimensioni dell'area di ascolto come mostrato nelle figure 2 e 3 (vedere anche l'esempio riportato di seguito).
4. La figura 2 mostra la forma prodotta da un'ottava a 1 kHz emessa dall'altoparlante; la figura 3 mostra la forma prodotta da un'ottava a 4 kHz. L'area di ascolto con le prestazioni acustiche ottimali si presenta in queste forme. Assicurarsi che la forma corrispondente all'ottava da 4 kHz con le dimensioni ottenute utilizzando il grafico 1 copra interamente l'area di ascolto desiderata.
5. In questo caso, il valore X sull'asse delle ordinate indica a quale altezza al di sopra del piano di ascolto è necessario installare l'altoparlante. Tenere presente che gli altoparlanti devono essere montati all'altezza stabilita con un'inclinazione di 8°.

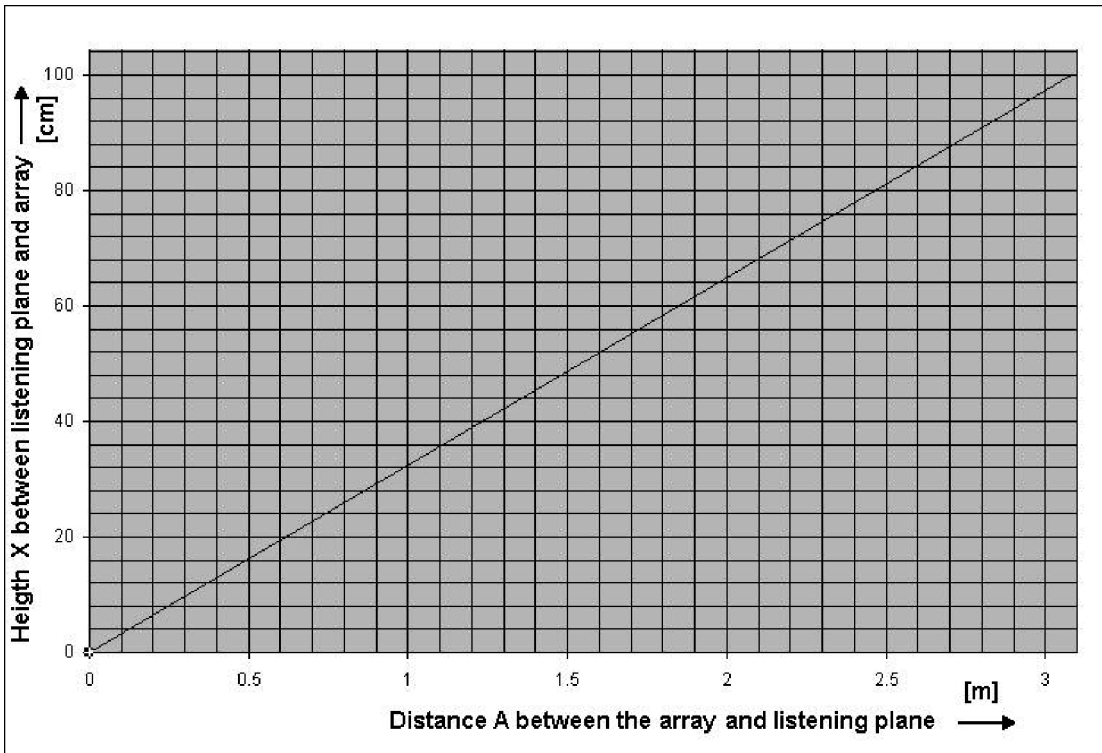
È ora possibile installare gli altoparlanti in modo da ottenere prestazioni acustiche ottimali.

Esempio:

La distanza massima tra l'altoparlante e l'ascoltatore più lontano è di 15 metri. Tracciare una linea verticale da questo punto sull'asse orizzontale del grafico 1 fino a intersecare la linea diagonale B, quindi tracciare una linea perpendicolare fino a incontrare l'asse delle ordinate. I punti di intersezione con le altre linee diagonali consentono di stabilire le dimensioni dei piani di ascolto. In questo esempio:

Linea F (lunghezza laterale del piano di ascolto a 4 kHz) = 11,1 m

Linea C (lunghezza del piano di ascolto) = 11 m

Linea E (piano di ascolto a metà larghezza a 4 kHz) = 9,3 m

Linea A (distanza minima dal piano di ascolto) = 3,9 m

Il valore X sull'asse verticale (ovvero l'altezza tra il piano di ascolto e la staffa di montaggio dell'altoparlante) è di 1,8 m.

Domande e risposte sull'installazione

- **L'area di ascolto desiderata è troppo grande e non si adatta alla forma prodotta a 4 kHz.**

Montare l'altoparlante a un'altezza diversa o utilizzare più altoparlanti per ottenere un'area di ascolto di maggiori dimensioni.

- **Perché l'inclinazione richiesta per l'altoparlante è di 8°?**

Le forme riportate nelle figure 2 e 3 con le dimensioni desunte dal grafico 1 sono valide solo quando l'altoparlante viene montato con un'inclinazione di 8°. Soltanto in questo caso il livello di pressione sonora e la risposta in frequenza (direttività costante) nell'area di ascolto restano costanti.

- **È possibile montare gli altoparlanti con un'altra inclinazione?**

È possibile installare gli altoparlanti scegliendo un'altra inclinazione ma le prestazioni acustiche non saranno ottimali. Ad esempio, nell'area di ascolto si percepirà una maggiore variazione del livello di pressione sonora. I valori del grafico 1 non sono validi se si scelgono altre inclinazioni. Si consiglia di non utilizzare in nessun caso un'inclinazione superiore a 8°.

- **Non è possibile installare l'altoparlante all'altezza desiderata.**

Se non è possibile installare l'altoparlante all'altezza desiderata poiché il soffitto non è sufficientemente alto, utilizzare un'inclinazione inferiore a 8°. Regolare l'asse degli altoparlanti corrispondente a 0° (l'asse centrale dell'area di ascolto) in corrispondenza della posizione massima desiderata (vedere figura 4). Tenere presente che la tabella del grafico 1 e le forme della figura 2 e 3 non sono valide in questo caso. Verificare che la qualità acustica nell'area di ascolto sia accettabile.

Informazioni generali:

- Queste forme sono definite in un ambiente anecoico. La variazione massima della pressione del livello sonoro di queste forme in condizioni anecoiche è di 6dB e si percepisce una variazione della risposta in frequenza inferiore. In ambienti con un livello di riverbero normale o elevato, si ottiene una minore variazione del livello di pressione sonora con forme di dimensioni maggiori. La risposta in frequenza percepita in questa forma rimane pressoché costante.
- Quando ci si allontana oltre l'area di ascolto (superando quindi la distanza massima dall'altoparlante), diminuisce solo il livello di pressione sonora e la variazione nell'altezza dei toni è trascurabile. La diminuzione del livello di pressione sonora varia in base al riverbero ambientale presente.

- Se la distanza dagli altoparlanti è inferiore alla distanza minima consentita, si verifica immediatamente l'assenza di toni alti.
- A seconda del riverbero ambientale e della zona d'ombra del suono (soggetti o oggetti situati davanti a un ascoltatore che ostacolano la sorgente sonora), la qualità acustica potrebbe diminuire se l'ascoltatore si trova lontano dagli altoparlanti. In questi casi, è consigliabile utilizzare più altoparlanti per suddividere l'area di ascolto.
- Le linee laterali riportate nelle forme delle figure 2 e 3 sono rappresentate dai punti a -6 dB relativi al livello di pressione sonora sull'asse corrispondente a 0° .
- Per ottenere una qualità acustica ottimale, determinare un'area di ascolto interamente coperta dalla forma prodotta da un'ottava a 4 kHz.
- Per stabilire con esattezza i limiti dell'area di ascolto, è necessario eseguire un test pratico nel punto di installazione degli altoparlanti. Tale procedura deve essere effettuata da un ascoltatore esperto. Per eseguire tale operazione, riprodurre una traccia con rumore rosa attraverso gli altoparlanti. Si consiglia di ridurre i toni bassi poiché riducono la qualità acustica. Ascoltare i toni alti in diversi punti dell'area di ascolto. Le zone in cui i toni alti diminuiscono rapidamente delimitano l'area di ascolto.



Grafico 1 - Relazione tra l'area di ascolto e l'altezza di montaggio degli altoparlanti

Significato delle linee orizzontali

Linea B: distanza massima tra l'altoparlante e l'ascoltatore più lontano

Linea D: piano di ascolto a metà larghezza a 1 kHz

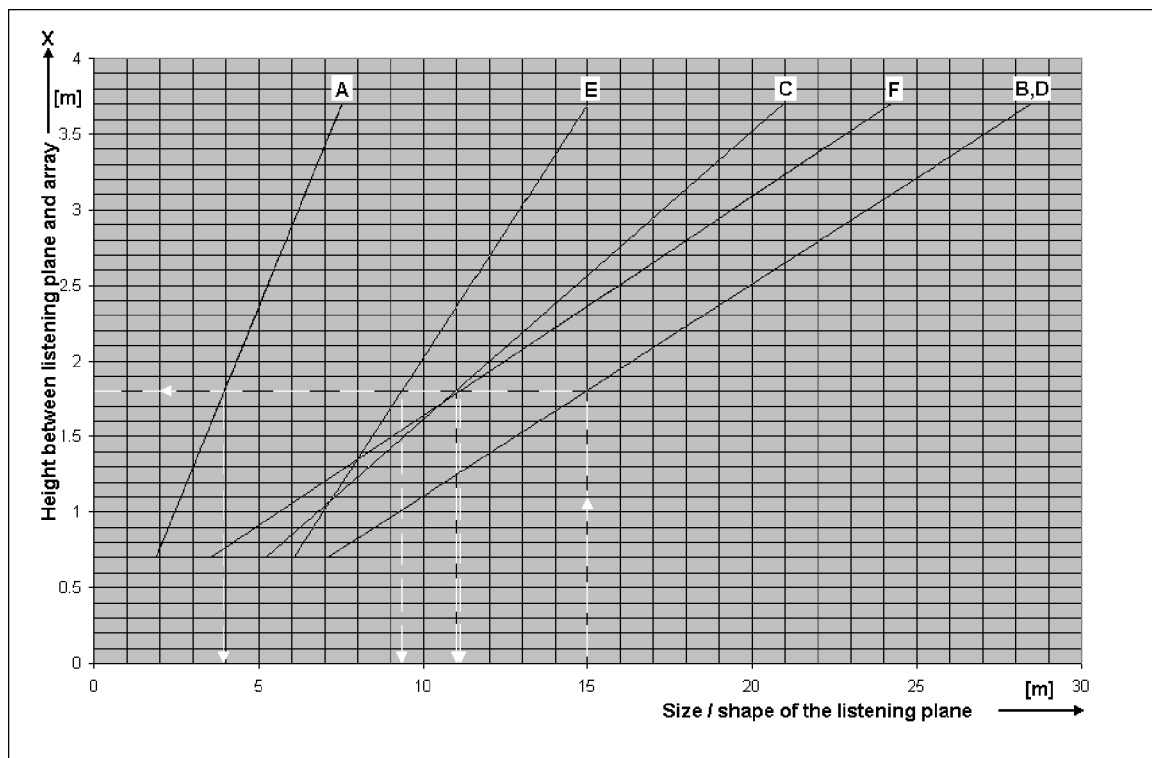
Linea F: lunghezza laterale del piano di ascolto a 4 kHz

Linea C: lunghezza del piano di ascolto

Linea E: piano di ascolto a metà larghezza a 4 kHz

Linea A: distanza minima dal piano di ascolto



Figura 1 - Vista laterale della radiazione acustica dell'altoparlante e del piano di ascolto



Figura 2 - Forma prodotta da un'ottava di 1 kHz emessa dall'altoparlante

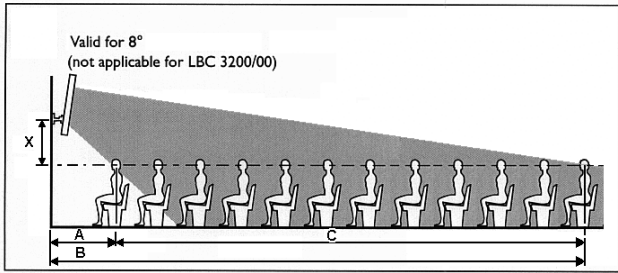

Figura 3 - Forma prodotta da un'ottava di 4 kHz emessa dall'altoparlante

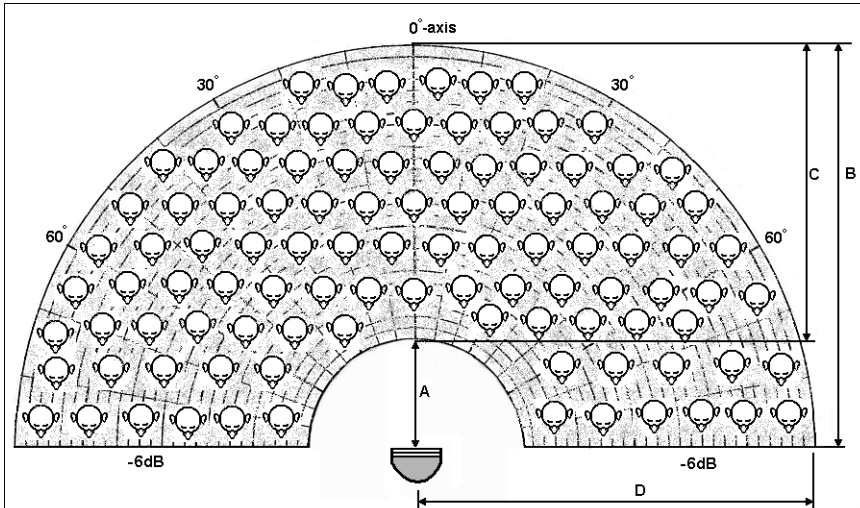

Figura 4 - Regolazione dell'asse degli altoparlanti corrispondente a 0° (asse centrale di ascolto) sulla posizione massima

Area di ascolto e relativa altezza di installazione per il modello XLA3210/00

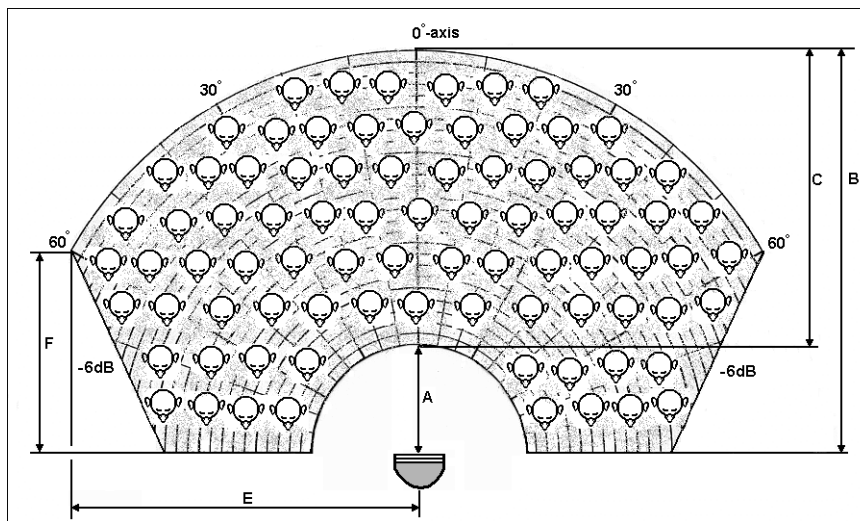
Istruzioni per il montaggio:

1. Determinare le dimensioni dell'"area di ascolto" desiderata, ovvero del piano orizzontale all'altezza delle orecchie degli ascoltatori (vedere la linea tratteggiata in figura 1).
2. Misurare la distanza massima tra gli altoparlanti e l'ascoltatore più lontano nell'area di ascolto (corrispondente al punto "B" nelle figure 1, 2 e 3).
3. Facendo riferimento al grafico 1, tracciare una linea verticale in corrispondenza del punto di massima distanza sull'asse delle ascisse. Dal punto di intersezione verticale con la linea B diagonale, tracciare una linea orizzontale rispetto all'asse delle ordinate. Il valore X, riferito all'altezza della staffa di montaggio degli altoparlanti dal piano di ascolto, ('X' in figura 1), si trova sull'asse delle ascisse. Le intersezioni orizzontali con le altre linee diagonali indicano le dimensioni dell'area di ascolto come mostrato nelle figure 2 e 3 (vedere anche l'esempio riportato di seguito).
4. La figura 2 mostra la forma prodotta da un'ottava a 1 kHz emessa dall'altoparlante; la figura 3 mostra la forma prodotta da un'ottava a 4 kHz. L'area di ascolto con le prestazioni acustiche ottimali si presenta in queste forme. Assicurarsi che la forma corrispondente all'ottava da 4 kHz con le dimensioni ottenute utilizzando il grafico 1 copra interamente l'area di ascolto desiderata.
5. In questo caso, il valore X sull'asse delle ordinate indica a quale altezza al di sopra del piano di ascolto è necessario installare l'altoparlante. Tenere presente che gli altoparlanti devono essere montati all'altezza stabilita con un'inclinazione di 8°.

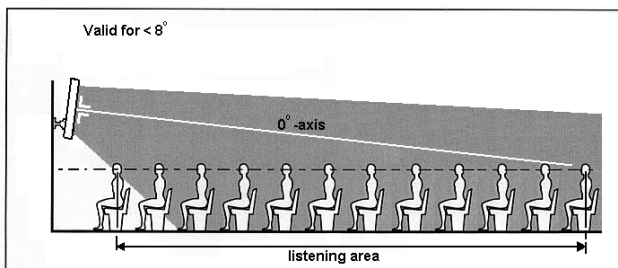
È ora possibile installare gli altoparlanti in modo da ottenere prestazioni acustiche ottimali.

Esempio riportato nel grafico:

La distanza massima tra l'altoparlante e l'ascoltatore più lontano è di 15 metri. Tracciare una linea verticale da questo punto sull'asse orizzontale del grafico 1 fino a intersecare la linea diagonale B, quindi tracciare una linea perpendicolare fino a incontrare l'asse delle ordinate. I punti di intersezione con le altre linee diagonali consentono di stabilire le dimensioni dei piani di ascolto. In questo esempio:

Linea F (lunghezza laterale del piano di ascolto s 4 kHz) = 12,2 m

Linea C (lunghezza del piano di ascolto) = 11 m

Linea E (piano di ascolto a metà larghezza a 4 kHz) = 8,6 m

Linea A (distanza minima dal piano di ascolto) = 3,9 m

Il valore X sull'asse verticale (ovvero l'altezza tra il piano di ascolto e la staffa di montaggio dell'altoparlante) è di 1,8 m.

Domande e risposte sull'installazione:

- **L'area di ascolto desiderata è troppo grande e non si adatta alla forma prodotta a 4 kHz.**

Montare l'altoparlante a un'altezza diversa o utilizzare più altoparlanti per ottenere un'area di ascolto di maggiori dimensioni.

- **Perché l'inclinazione richiesta per l'altoparlante è di 8°?**

Le forme riportate nelle figure 2 e 3 con le dimensioni desunte dal grafico 1 sono valide solo quando l'altoparlante viene montato con un'inclinazione di 8°. Soltanto in questo caso il livello di pressione sonora e la risposta in frequenza (direttività costante) nell'area di ascolto restano costanti.

- **È possibile montare gli altoparlanti con un'altra inclinazione?**

È possibile installare gli altoparlanti scegliendo un'altra inclinazione ma le prestazioni acustiche non saranno ottimali. Ad esempio, nell'area di ascolto si percepirà una maggiore variazione del livello di pressione sonora. I valori del grafico 1 non sono validi se si scelgono altre inclinazioni. Si consiglia di non utilizzare in nessun caso un'inclinazione superiore a 8°.

- **Non è possibile installare l'altoparlante all'altezza desiderata.**

Se non è possibile installare l'altoparlante all'altezza desiderata poiché il soffitto non è sufficientemente alto, utilizzare un'inclinazione inferiore a 8°. Regolare l'asse degli altoparlanti corrispondente a 0° (l'asse centrale dell'area di ascolto) in corrispondenza della posizione massima desiderata (vedere figura 4). Tenere presente che la tabella del grafico 1 e le forme della figura 2 e 3 non sono valide in questo caso. Verificare che la qualità acustica nell'area di ascolto sia accettabile e che i messaggi vengano recepiti con chiarezza.

Informazioni generali:

- Queste forme sono definite in un ambiente anecoico. La variazione massima della pressione del livello sonoro di queste forme in condizioni anecoiche è di 6dB e si percepisce una variazione della risposta in frequenza inferiore. In ambienti con un livello di riverbero normale o elevato, si ottiene una minore variazione del livello di pressione sonora con forme di dimensioni maggiori. La risposta in frequenza percepita in questa forma rimane pressoché costante.
- Quando ci si allontana oltre l'area di ascolto (superando quindi la distanza massima dall'altoparlante), diminuisce solo il livello di pressione sonora e la variazione nell'altezza dei toni è trascurabile. La diminuzione del livello di pressione sonora varia in base al riverbero ambientale presente.
- Se la distanza dagli altoparlanti è inferiore alla distanza minima consentita, si verifica immediatamente l'assenza di toni alti.
- A seconda del riverbero ambientale e della zona d'ombra del suono (soggetti o oggetti situati davanti a

un ascoltatore che ostacolano la sorgente sonora), la qualità acustica potrebbe diminuire se l'ascoltatore si trova lontano dagli altoparlanti. In questi casi, è consigliabile utilizzare più altoparlanti per suddividere l'area di ascolto.

- Le linee laterali riportate nelle forme delle figure 2 e 3 sono rappresentate dai punti a -6 dB relativi al livello di pressione sonora sull'asse corrispondente a 0°.
- Per ottenere una qualità acustica ottimale, determinare un'area di ascolto interamente coperta dalla forma prodotta da un'ottava a 4 kHz. Per stabilire con esattezza i limiti dell'area di ascolto, è necessario eseguire un test pratico nel punto di installazione degli altoparlanti. Tale procedura deve essere effettuata da un ascoltatore esperto. Per eseguire tale operazione, riprodurre una traccia con rumore rosa attraverso gli altoparlanti. Si consiglia di ridurre i toni bassi poiché riducono la qualità acustica. Ascoltare i toni alti in diversi punti dell'area di ascolto. Le zone in cui i toni alti diminuiscono rapidamente delimitano l'area di ascolto.



Grafico 1 - Relazione tra l'area di ascolto e l'altezza di montaggio degli altoparlanti

Significato delle linee

- Linea B: distanza massima tra l'altoparlante e l'ascoltatore più lontano
- Linea D: piano di ascolto a metà larghezza a 1 kHz
- Linea F: lunghezza laterale del piano di ascolto a 4 kHz
- Linea C: lunghezza del piano di ascolto
- Linea E: piano di ascolto a metà larghezza a 4 kHz
- Linea A: distanza minima dal piano di ascolto

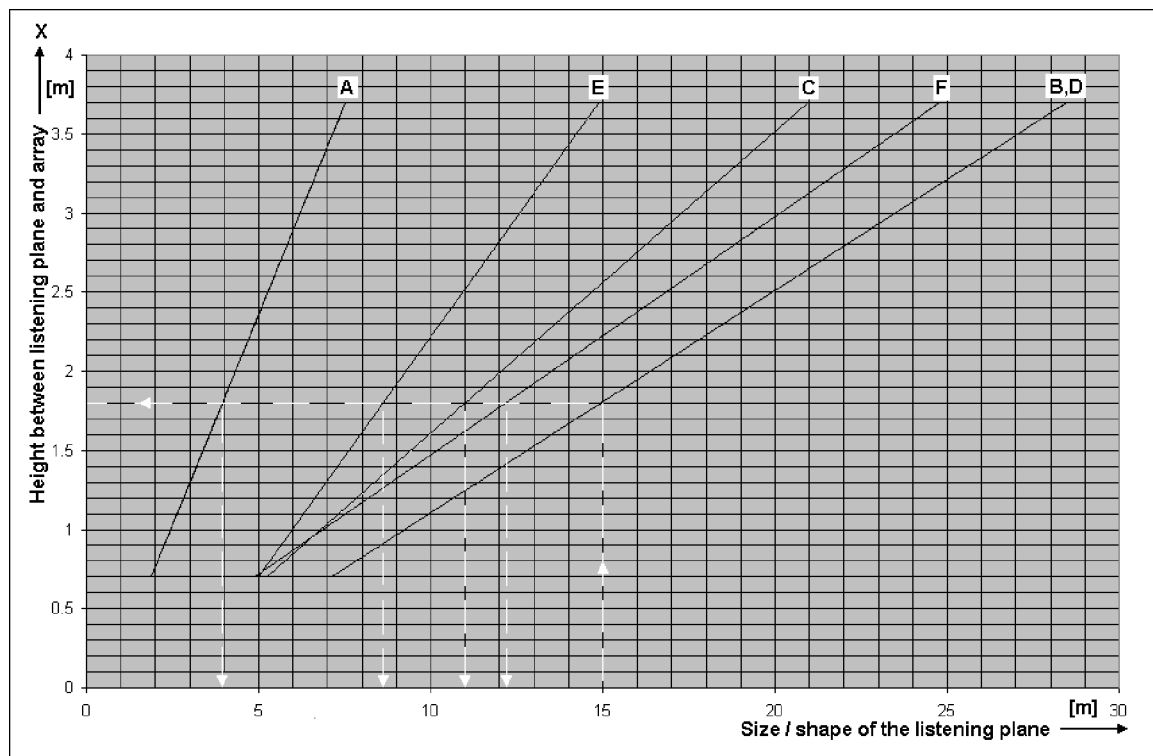

Figura 1 - Vista laterale della radiazione acustica dell'altoparlante e del piano di ascolto



Figura 2 - Forma prodotta da un'ottava di 1 kHz emessa dall'altoparlante

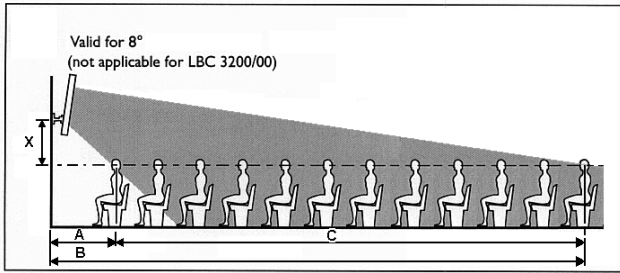

Figura 3 - Forma prodotta da un'ottava di 4 kHz emessa dall'altoparlante

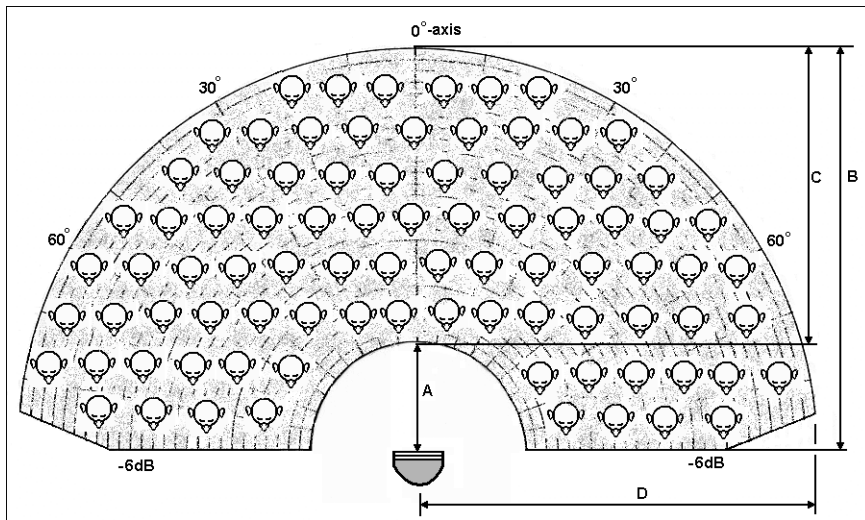

Figura 4 - Regolazione dell'asse degli altoparlanti corrispondente a 0° (asse centrale di ascolto) sulla posizione massima

DATI TECNICI RELATIVI ALLE PRESTAZIONI

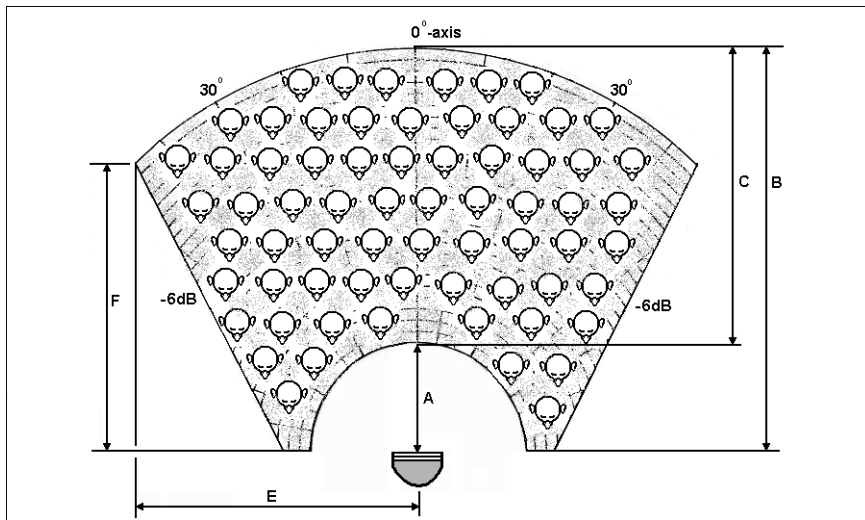
LBC 3200/00

Potenza massima	45 W
Potenza nominale	30 W (30-15-7,5 W)
Livello di pressione sonora a	
30 W/1 W (a 1 kHz, 1 m)	106 dB/91 dB (SPL)
Gamma di frequenze effettiva (-10 dB)	da 190 Hz a 18 kHz
Angolo di apertura	
(a 1 kHz/4 kHz, -6 dB)	
Orizzontale	220°/130°
Verticale	70°/18°
Tensione di ingresso nominale	100 V
Impedenza nominale	333 Ohm
Intervallo temperatura ambientale	da -25 a 55 °C
Sicurezza	conforme allo standard EN 60065
Connesione	blocco terminale a vite
Dimensioni (AxLxP)	600 x 80 x 90 mm
Colore	argento
Peso	3 kg

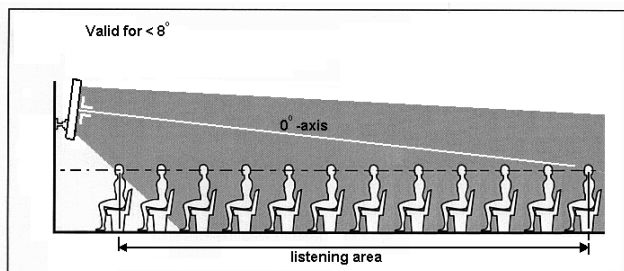
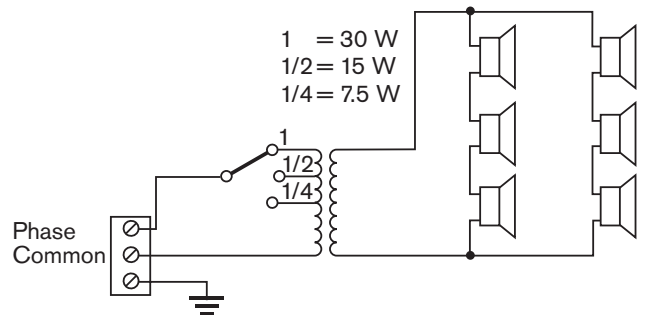
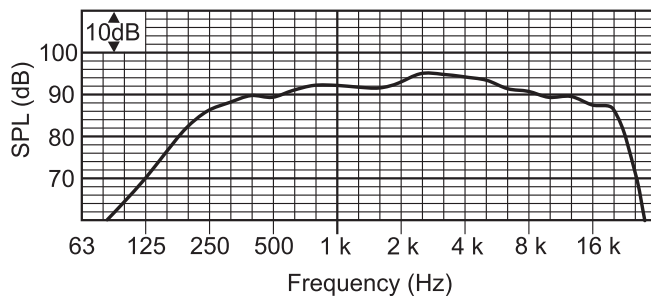

LBC 3200/00

Banda d'ottava (Hz)	250	500	1 k	2 k	4 k	8 k
SPL 1.1	87	89	91	93	93	89
SPL max	102	104	106	108	108	104
Fattore Q	1.3	2.2	4.5	11.6	25.7	58.9
Angolo orizzontale (gradi)	360	360	220	190	130	100
Angolo verticale (gradi)	360	120	70	32	18	10

Orizzontale

Verticale

LBC 3200/00
250Hz horizontal

LBC 3200/00
250Hz vertical

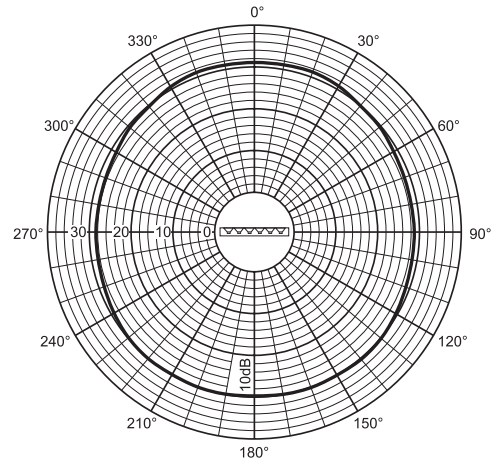
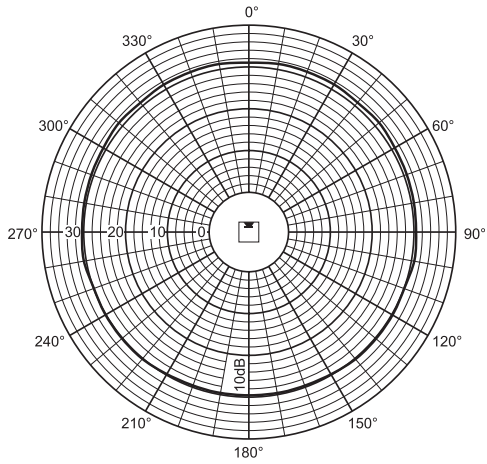

LBC 3200/00
500Hz horizontal

LBC 3200/00
500Hz vertical

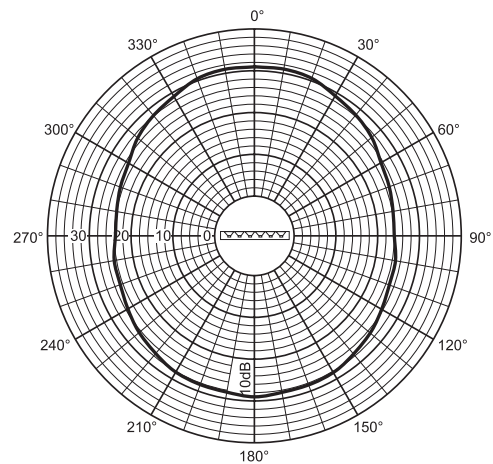
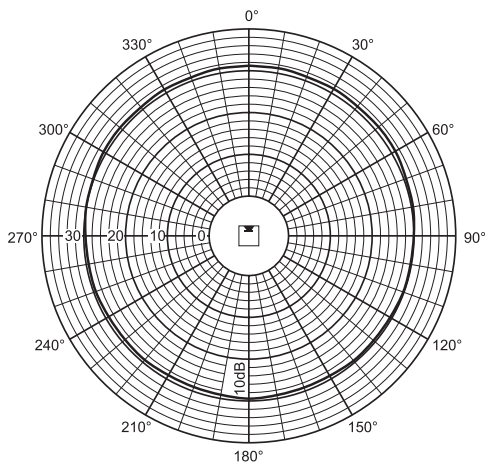

LBC 3200/00
1kHz horizontal

LBC 3200/00
1kHz vertical

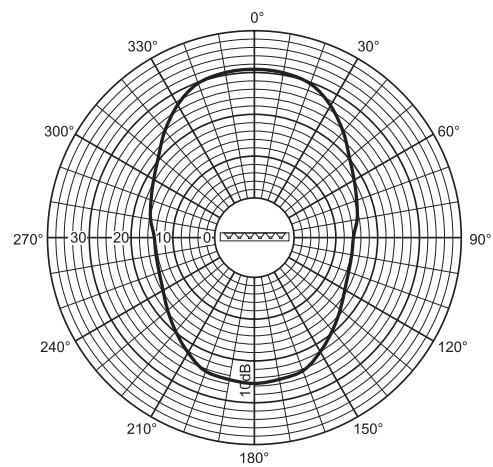
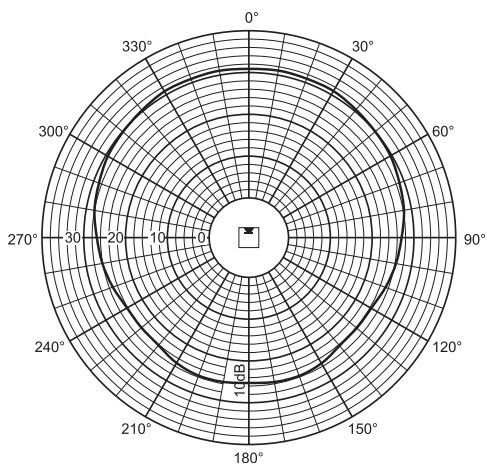

Orizzontale

Verticale

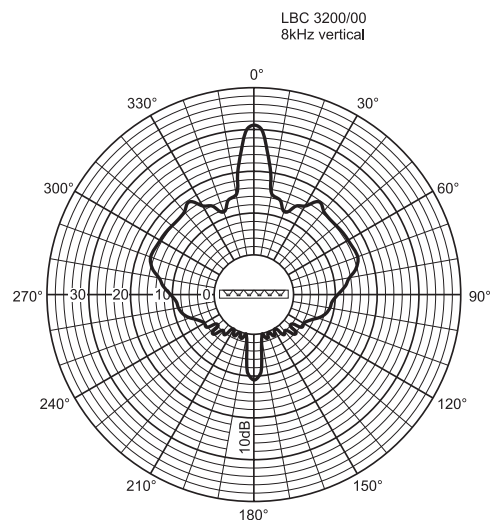
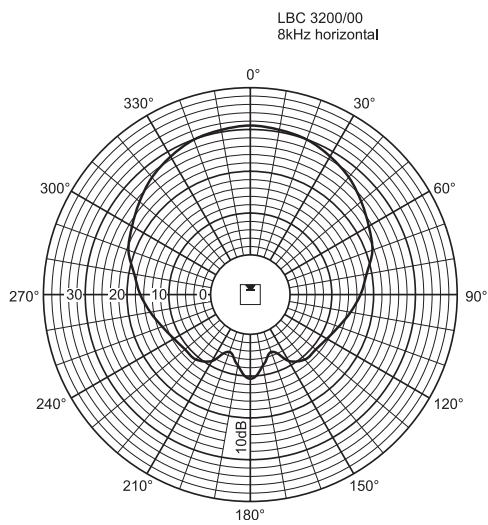
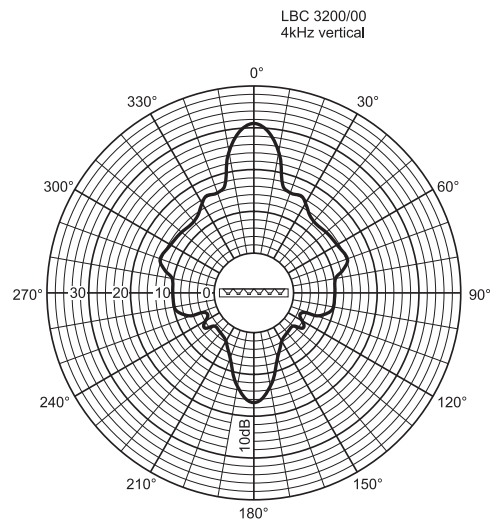
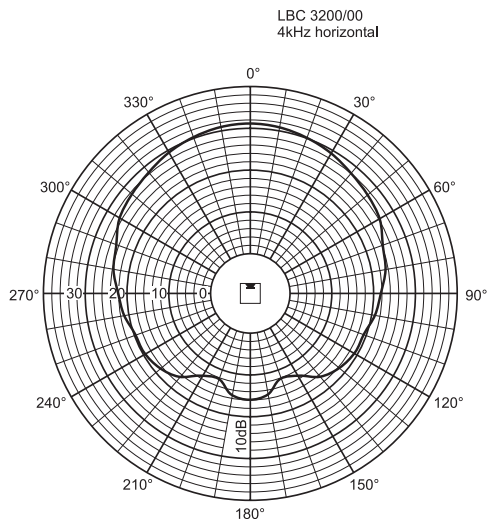
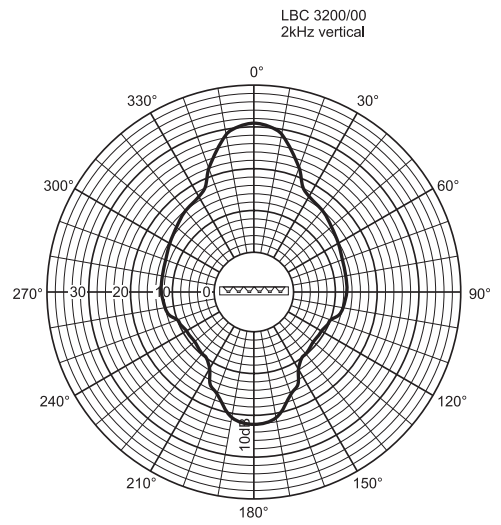
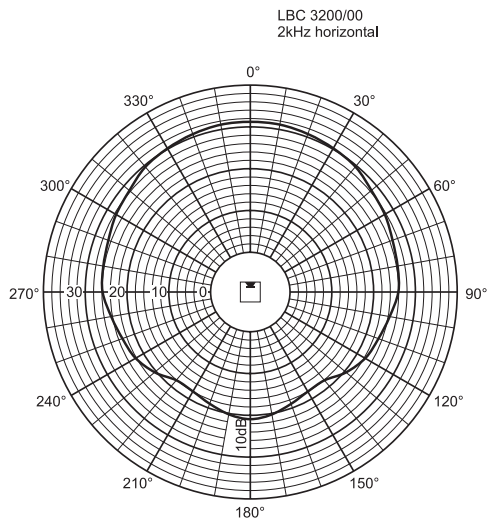

DATI TECNICI RELATIVI ALLE PRESTAZIONI

LBC 3201/00

Potenza massima	90 W
Potenza nominale	60 W (60-30-15 W)
Livello di pressione sonora a	
60 W/1 W (a 1 kHz, 1 m)	110 dB/92 dB (SPL)
Gamma di frequenze effettiva (-10 dB) da 190 Hz a 18 kHz	
Angolo di apertura	
(a 1 kHz/4 kHz, -6 dB)	
Orizzontale	210°/132°
Verticale	50°/22°
Tensione di ingresso nominale	100 V
Impedenza nominale	167 Ohm
Intervallo temperatura ambientale	da -25 a 55 °C
Sicurezza	
	conforme allo standard EN
	60065
Connessione	blocco terminale a vite
Dimensioni (AxLxP)	1200 x 80 x 90 mm
Colore	argento
Peso	6,4 kg

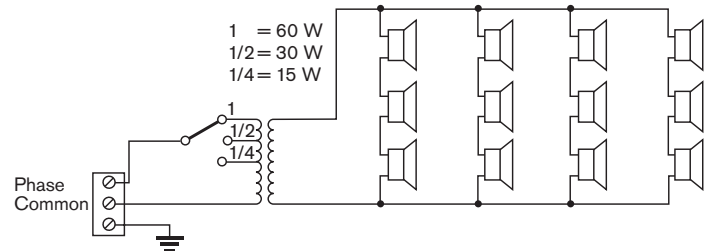
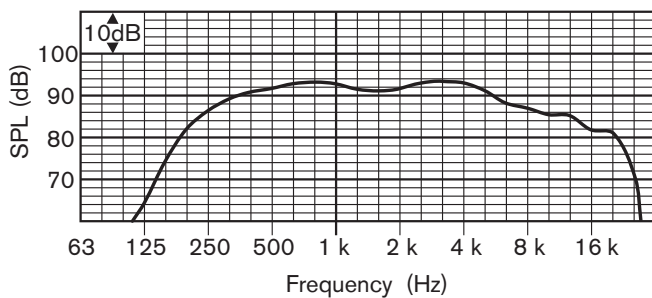

LBC 3201/00

Banda d'ottava (Hz)	250	500	1 k	2 k	4 k	8 k
SPL 1.1	88	92	92	91	91	86
SPL max	106	110	110	109	109	104
Fattore Q	2,2	3,2	6,5	12,6	23,4	53,3
Angolo orizzontale (gradi)	360	360	210	192	132	100
Angolo verticale (gradi)	107	67	50	33	22	12

Orizzontale

Verticale

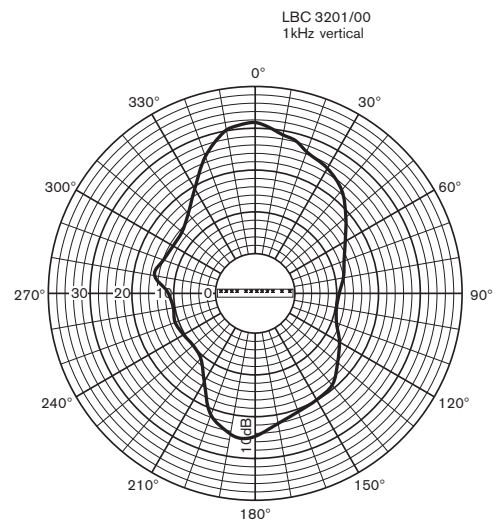
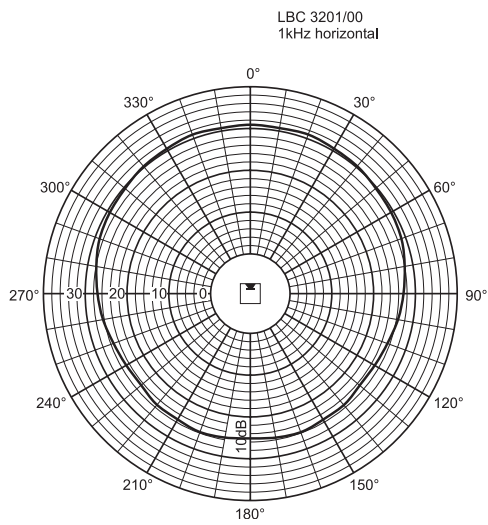
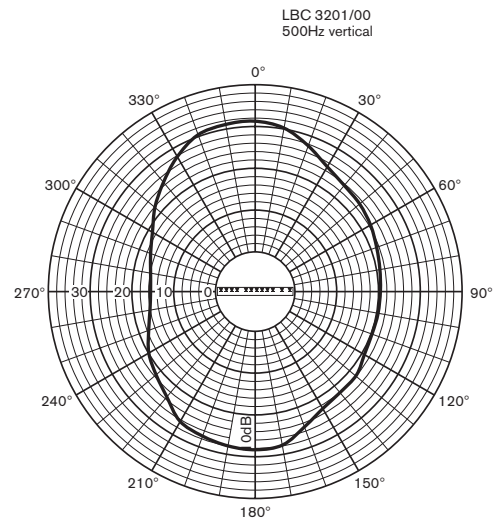
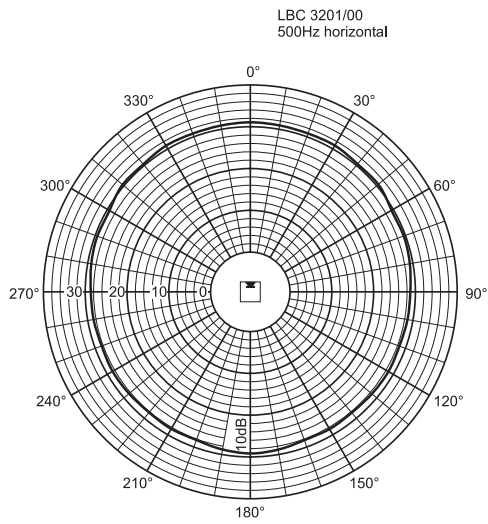
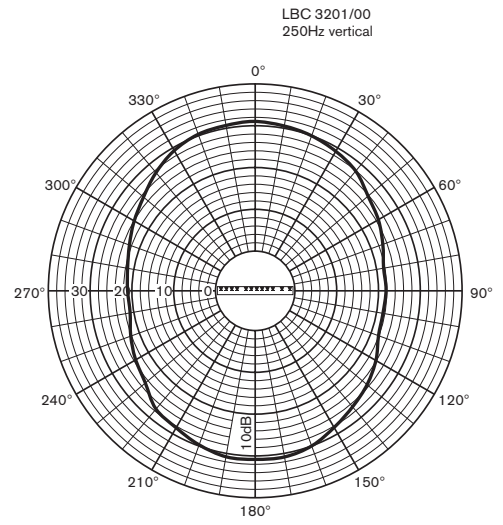
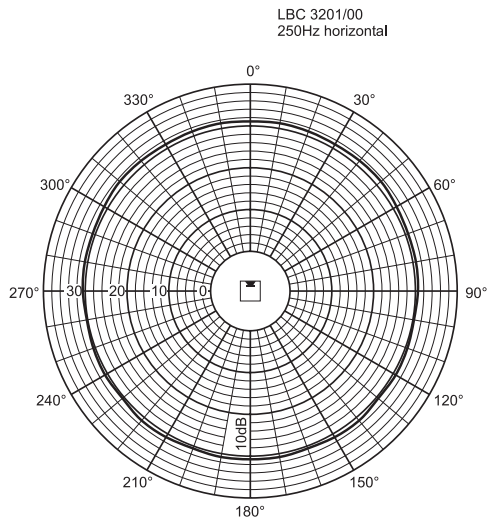

Orizzontale

Verticale

LBC 3201/00
2kHz horizontal

LBC 3201/00
2kHz vertical

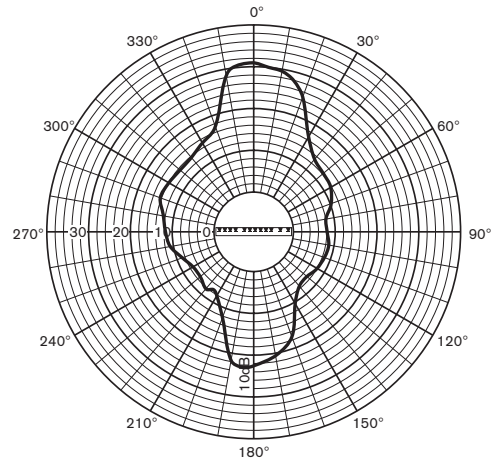
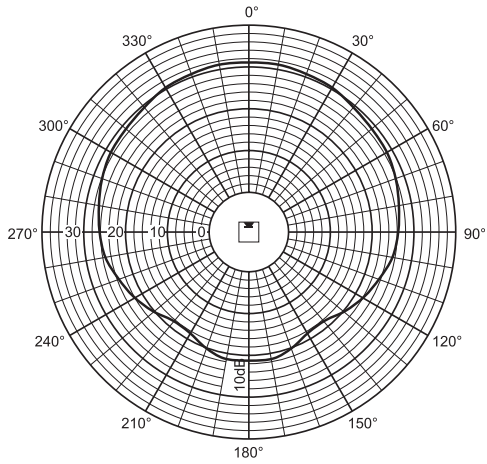

LBC 3201/00
4kHz horizontal

LBC 3201/00
4kHz vertical

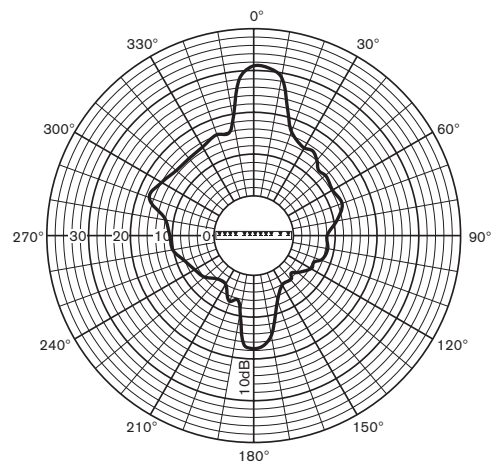
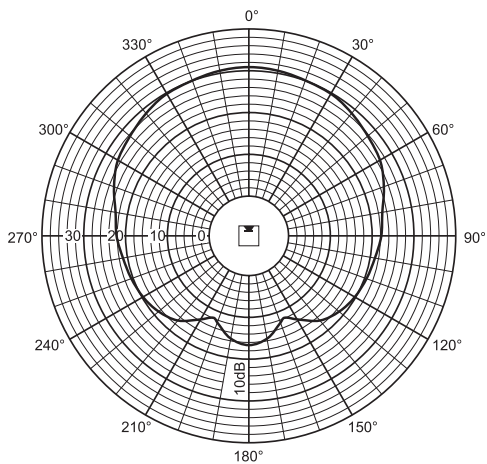

LBC 3201/00
8kHz horizontal

LBC 3201/00
8kHz vertical

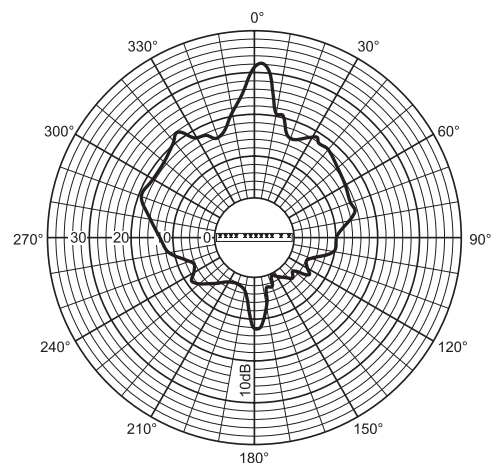
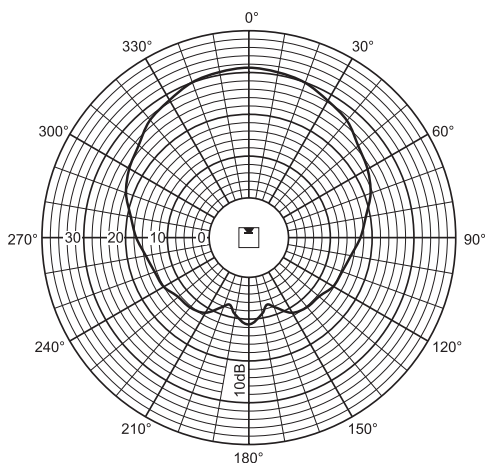

DATI TECNICI RELATIVI ALLE PRESTAZIONI**LBC 3210/00**

Potenza massima	90 W
Potenza nominale	60 W (60-30-15 W)
Livello di pressione sonora	
a 60 W/1 W (a 1 kHz, 1 m)	115 dB/97 dB (SPL)
Gamma di frequenze effettiva (-10 dB) da 190 Hz a 20 kHz	
Angolo di apertura	
(a 1 kHz/4 kHz, -6 dB)	
Orizzontale	170°/90°
Verticale	55°/18°
Tensione di ingresso nominale	100 V
Impedenza nominale	167 Ohm
Intervallo temperatura ambientale	da -25 a 55 °C
Sicurezza	conforme allo standard EN 60065
Protezione da acqua/polvere	IP 66 conforme allo standard IEC 60529
Connessione	blocco terminale a vite
Dimensioni (AxLx P)	1200 x 160 x 90 mm
Colore	argento
Peso	9 kg

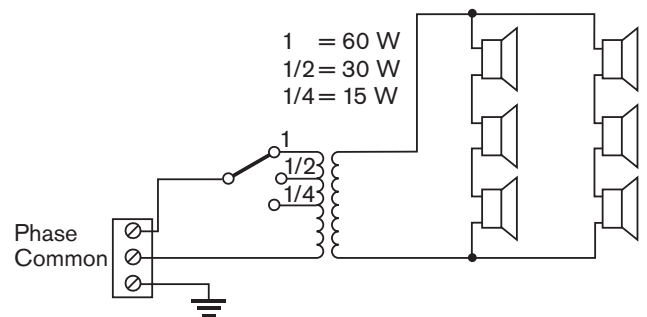
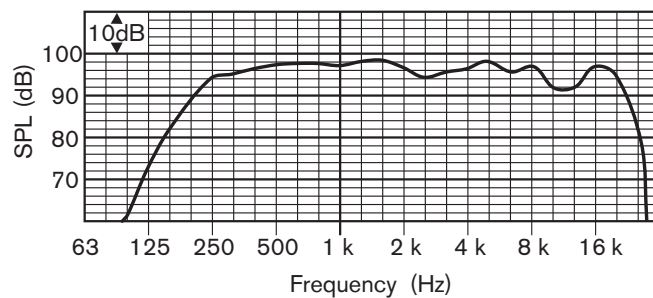
**LBC 3210/00**

Banda d'ottava (Hz)	250	500	1 k	2 k	4 k	8 k
SPL 1.1	94	97	97	95	96	93
SPL max	112	115	115	113	114	111
Fattore Q	2,2	2,7	6,3	10,8	22,6	32,3
Angolo orizzontale (gradi)	360	180	170	160	90	60
Angolo verticale (gradi)	100	60	55	34	18	10

Orizzontale

Verticale

LBC 3210/00
250Hz horizontal

LBC 3210/00
250Hz vertical

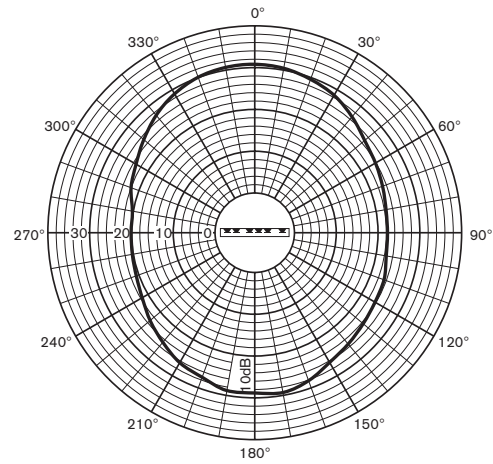
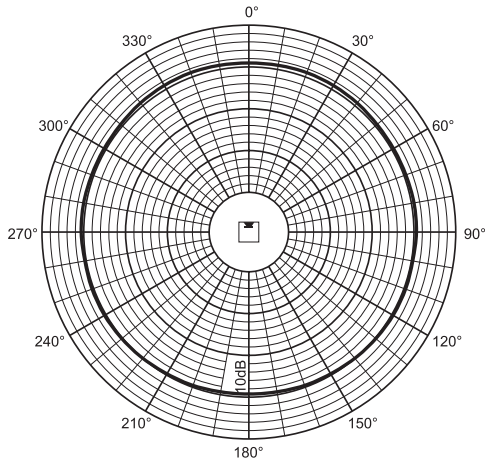

LBC 3210/00
500Hz horizontal

LBC 3210/00
500Hz vertical

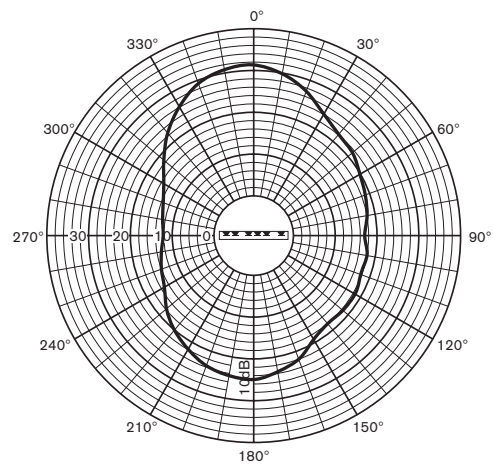
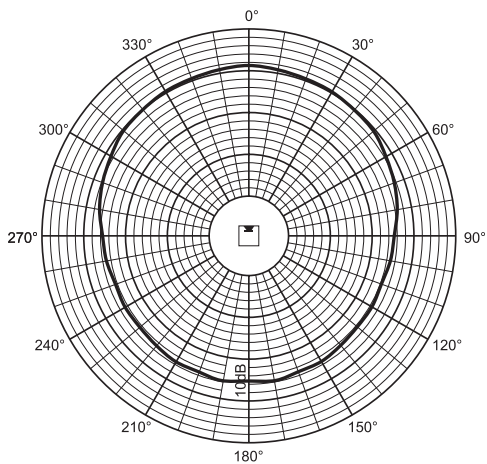

LBC 3210/00
1kHz horizontal

LBC 3210/00
1kHz vertical

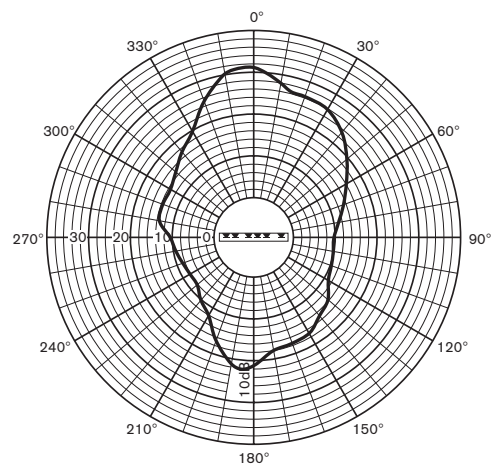
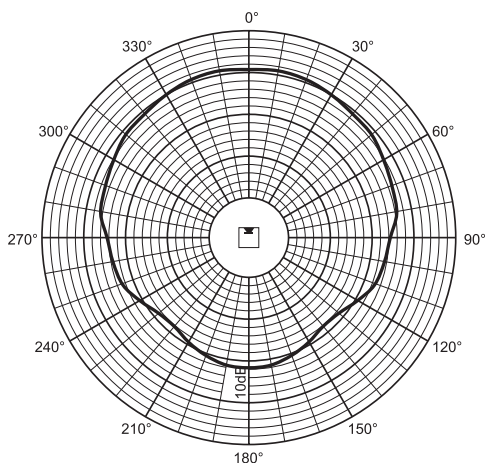

Orizzontale

Verticale

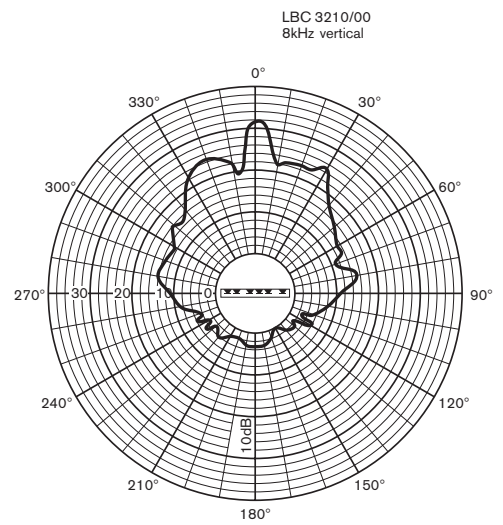
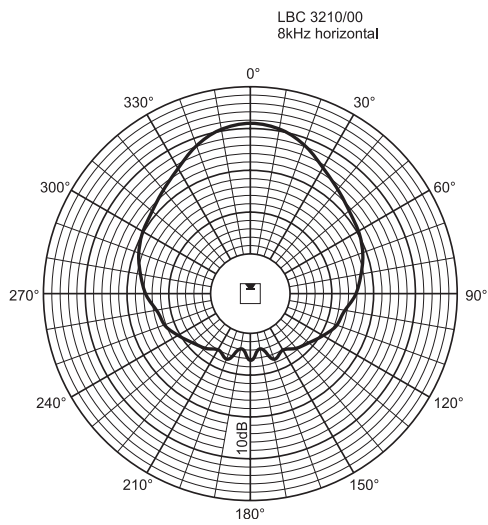
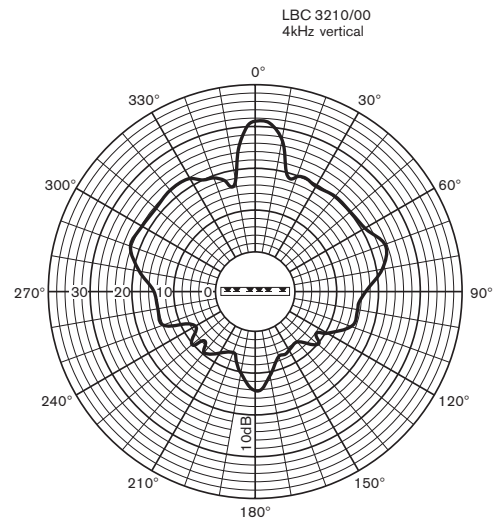
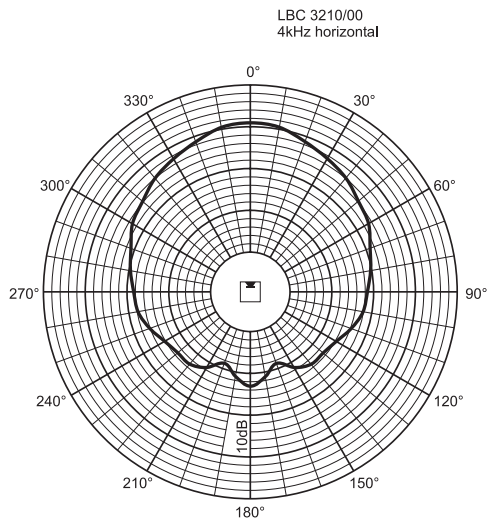
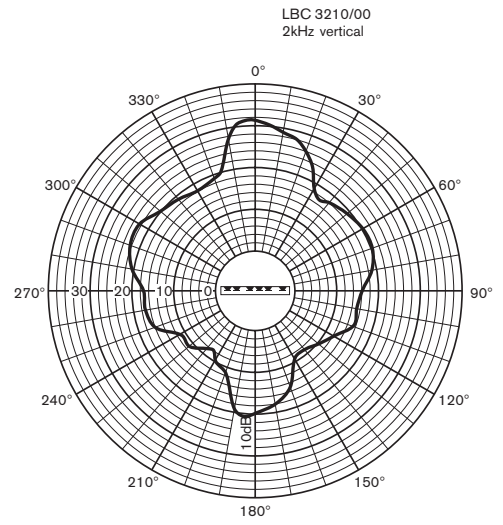
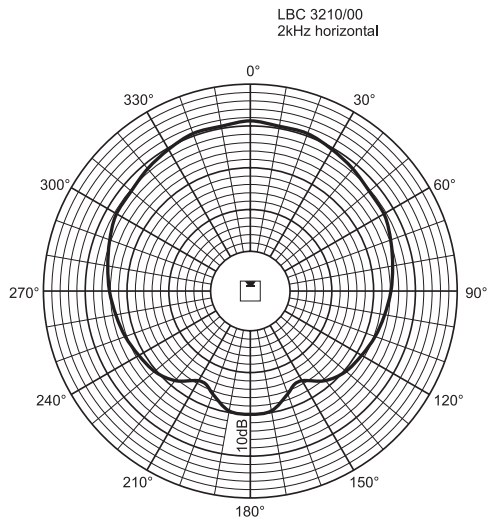

www.boschsecuritysystems.com

BOSCH

Índice	Página
Guia de instalação (fig. 1 - fig. 17)	138
Montagem do quadro de supervisão de linha/altifalante (opcional) (fig. A1 - fig. A5)	140
Montagem de suporte adicional (opcional) (fig. B1 - fig. B5).....	140
Montagem de suporte de chão (opcional) (fig. C1 - fig. C3)	140
Área de audição e altura de fixação da LBC 3200/00	141
Área de audição e altura de fixação da LBC 3201/00	143
Área de audição e altura de fixação da LBC 3210/00	146
Dados técnicos da LBC 3200/00	149
Dados técnicos da LBC 3201/00	152
Dados técnicos da LBC 3210/00	155

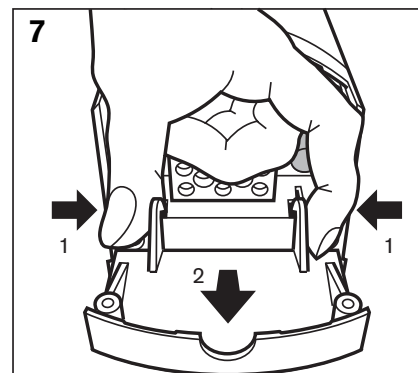
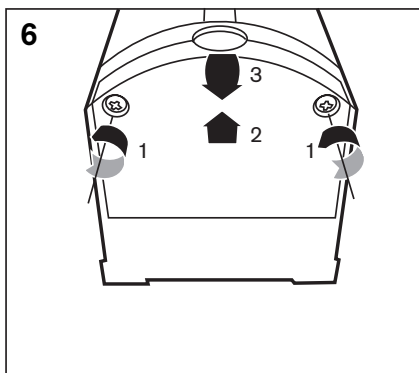
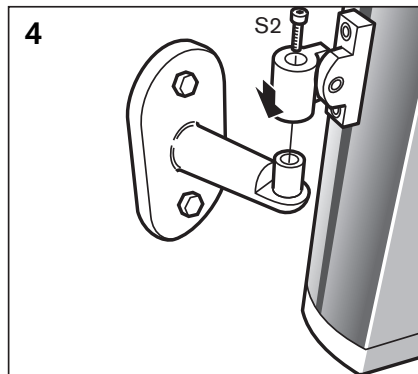
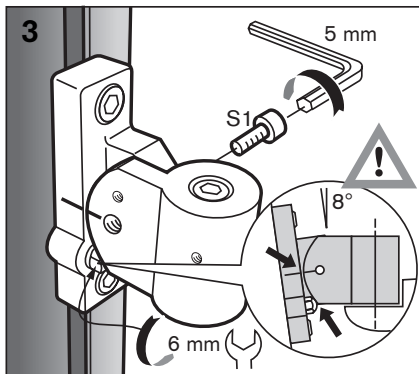
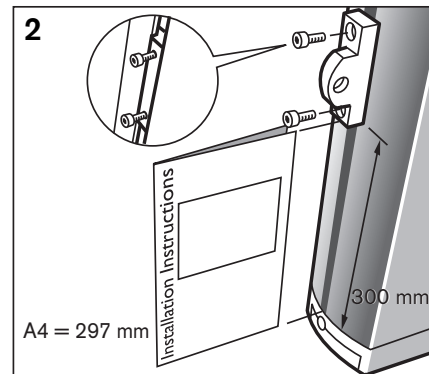
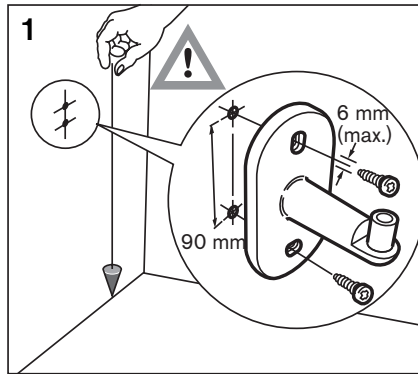
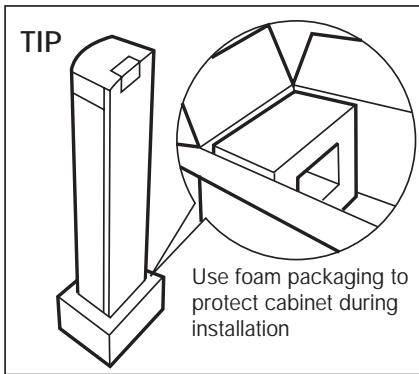
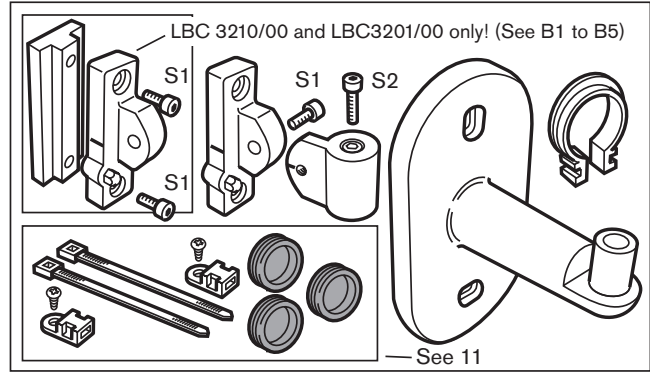
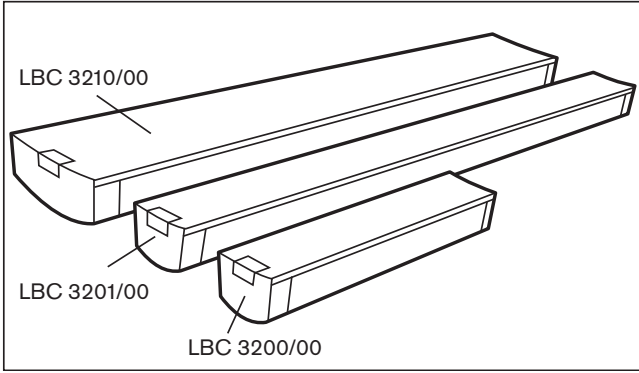

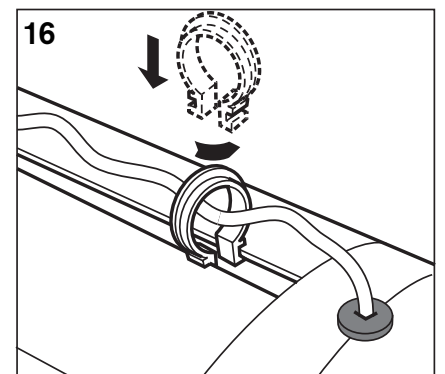
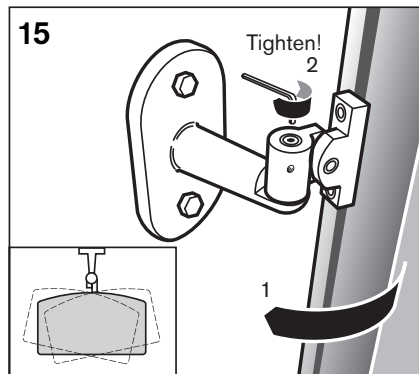
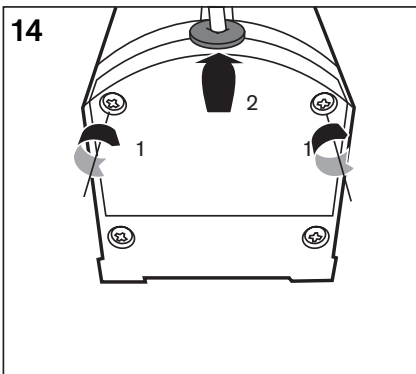
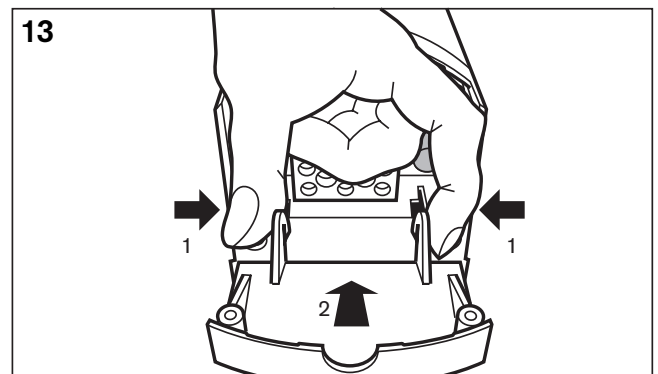
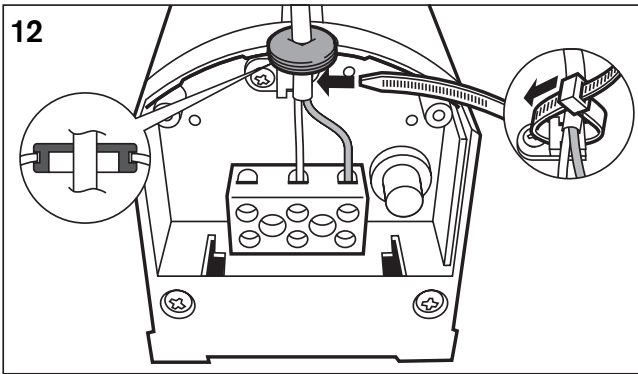
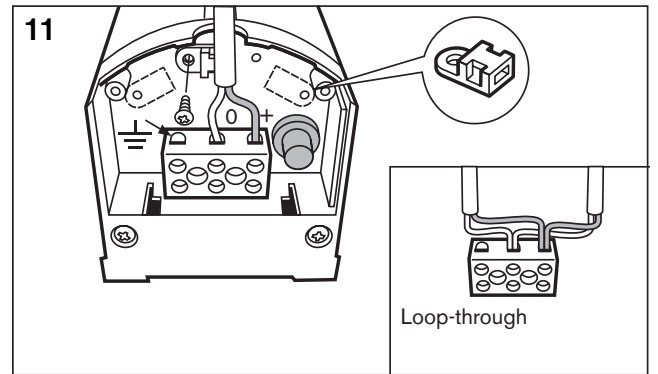
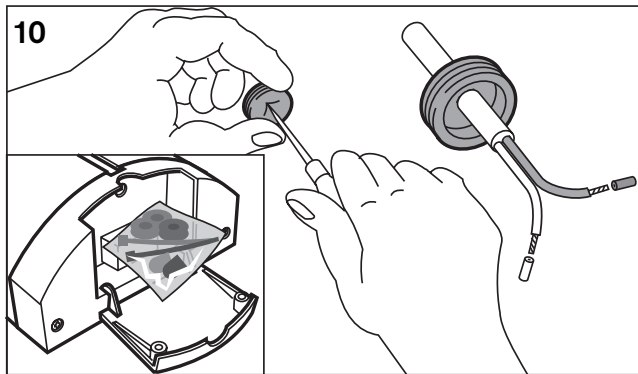
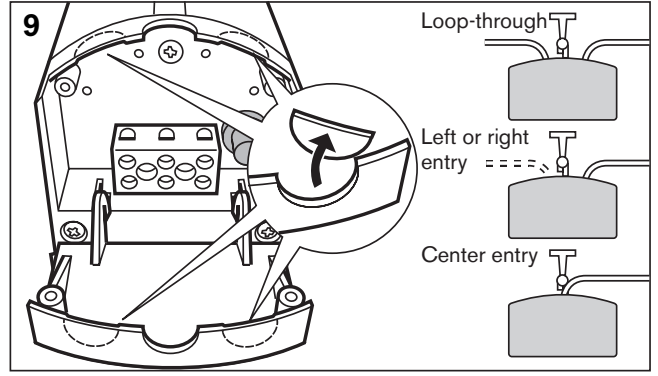
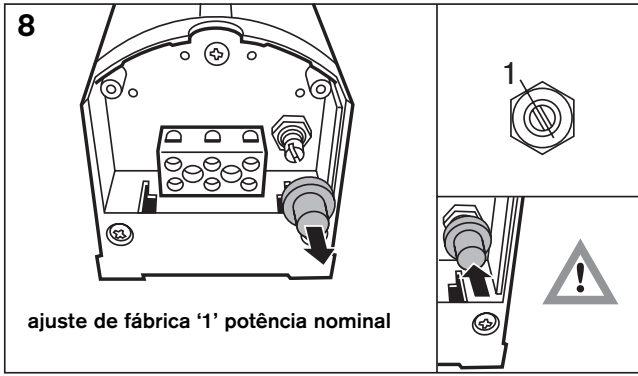

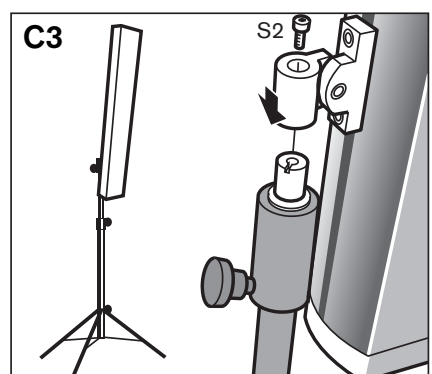
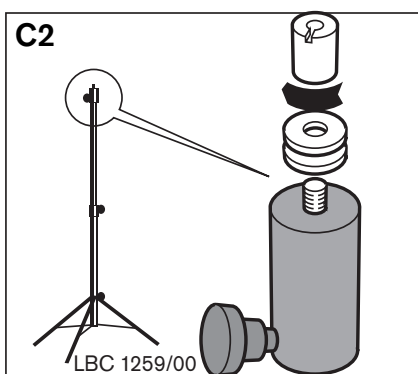
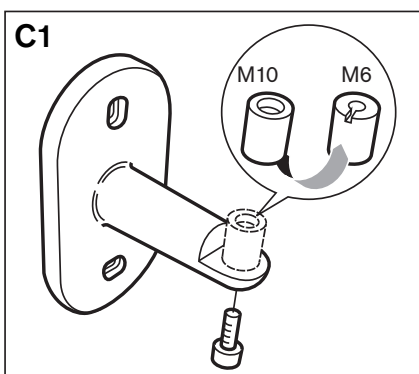
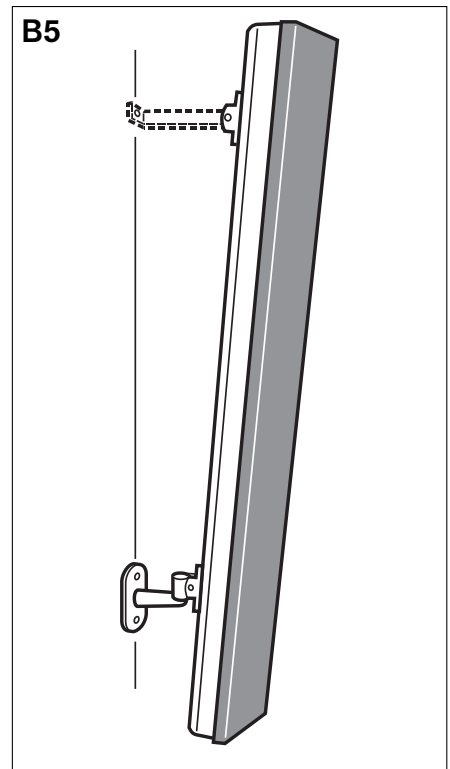
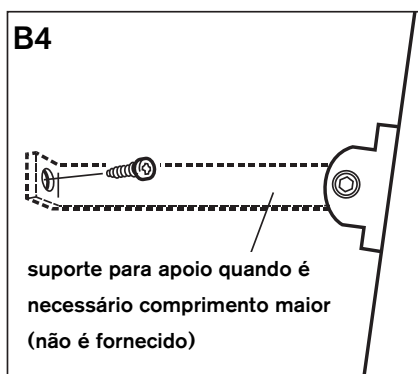
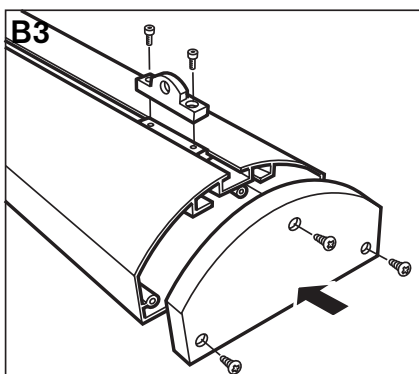
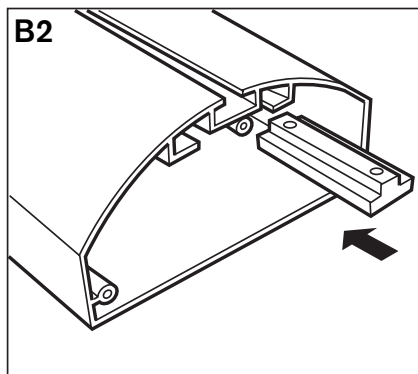
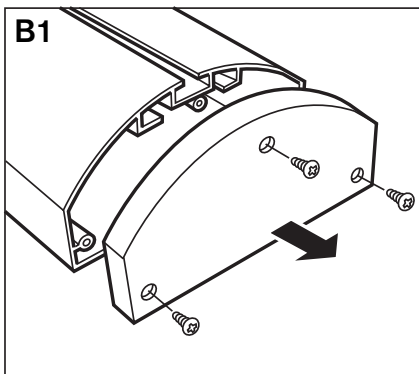
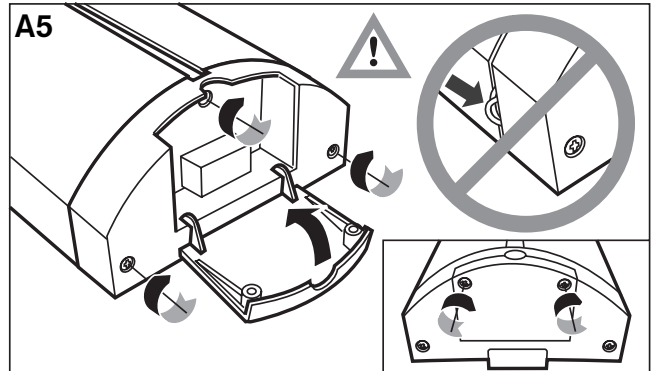
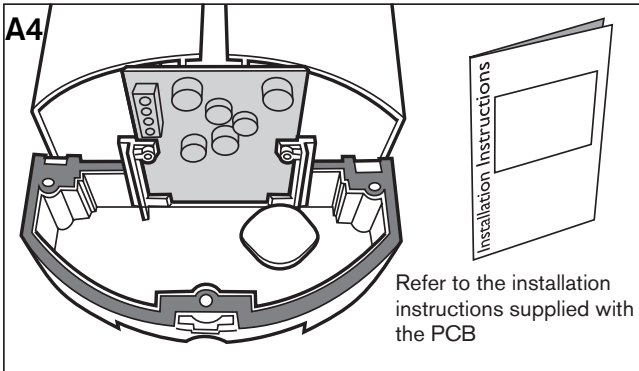
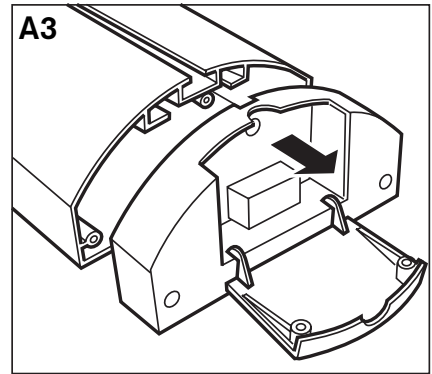
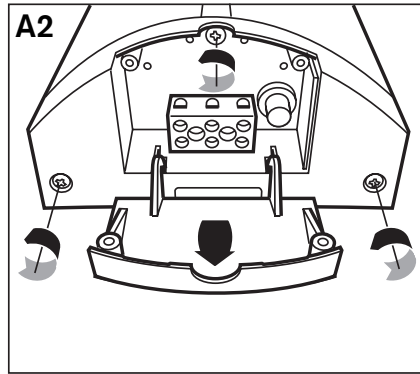
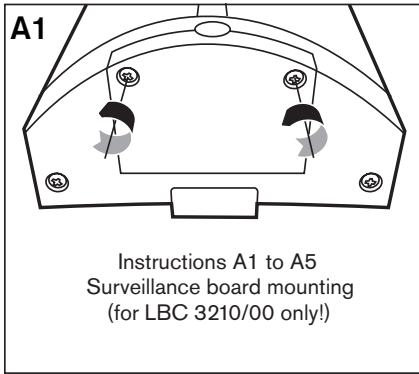

Área de audição e altura de fixação correspondente para XLA3200/00

Determinar a altura e o ângulo de montagem para a coluna linear de altifalantes LBC3200:

- Determine as dimensões da 'área de audição' desejada (num plano horizontal ao nível dos ouvidos dos ouvintes – consulte a linha tracejada na figura 1).
- Determine o ângulo em que a coluna linear será fixada. O conjunto foi concebido para emitir som logo acima da cabeça dos ouvintes e não deve exceder um ângulo de 6°. Existem duas possibilidades, cada uma delas com vantagens e desvantagens.
 - Possibilidade 1: Área de audição maximizada
Quando quiser uma área de audição alargada, recomendamos um ângulo de cerca de 3° (ver figura 1). Lembre-se que ao afastar-se da coluna linear de altifalantes, o nível de pressão sonora irá diminuir, num valor que depende da reverberação do compartimento. Para ouvir sons agudos de forma clara, o ouvinte deve conseguir ver a coluna linear de altifalantes.
 - Possibilidade 2: Variação mínima do nível de pressão sonora
Quando quiser uma variação mínima do nível da pressão sonora, recomendamos um ângulo de 5°. Note que este procedimento reduz o tamanho da área de audição total relativamente à possibilidade 1, e que o espaço muito perto da coluna linear de altifalantes ('A' na figura 2) não faz parte da área de audição. O diagrama 1 apresenta a relação entre 'A' e a altura de fixação da coluna linear de altifalantes quando utilizar um ângulo de instalação de 5°.
- Depois de seleccionar a possibilidade mais adequada (ângulo de montagem), a altura de montagem das colunas é determinada pela orientação do eixo 0° da coluna linear de altifalantes para a posição desejada, logo acima do ouvido do ouvinte mais afastado. Isto pode ser ajustado através da fixação da coluna mais acima ou mais abaixo na parede.

Agora pode instalar a coluna linear de altifalantes para obter o melhor desempenho acústico

Perguntas e respostas sobre a instalação:

- Posso instalar a coluna linear de altifalantes LBC3200 da mesma forma que a LBC3210 ou a LBC3201?**
Esta coluna de altifalantes foi concebido para ambientes interiores de espaço médio a reduzido. O desempenho acústico ideal desta coluna linear de altifalantes obtém-se através do direccionamento do som para uma altura logo acima da cabeça dos ouvintes. Quando instalar esta coluna linear de altifalantes da mesma forma que o

LBC3210 ou LBC3201, obtém uma área de audição muito reduzida. É também por essa razão que não deve utilizar um ângulo superior a 6°.

- Se não conseguir ver a coluna linear de altifalantes, isso significa que não irei ouvir os sons agudos?**
Pode comparar os sons agudos com a luz. Quando existir algum objecto entre si e a fonte de luz, não consegue ver a fonte de luz na sua totalidade. A isto chamamos sombra. O mesmo se passa com os sons agudos. Quando estão muitas pessoas sentadas entre si e a coluna, está na 'sombra' do som. Isso tem como efeito uma redução dos sons agudos.

Informação básica:

- Devido aos vários ângulos de instalação torna-se difícil obter uma forma definida do som emitido a partir da coluna linear de altifalantes.
- Se instalar a coluna linear num ângulo pequeno, pode obter uma área de audição (muito) ampla. Dependendo do nível de reverberação do compartimento e da 'sombra' do som (pessoas ou objectos à frente do ouvinte que estão a bloquear a fonte directa de som) a inteligibilidade do discurso pode ser fraca numa posição afastada. Nestas situações, será conveniente utilizar mais colunas para ampliar a área de audição.
- Quando se afasta ainda mais da posição máxima da área de audição (mais do que a distância máxima da coluna linear de altifalantes), diminui apenas o nível de pressão sonora. Quase não existe variação na tonalidade. A diminuição do nível de pressão sonora depende em grande parte da reverberação do compartimento.
- Quando está muito próximo da coluna linear de altifalantes (menos que a distância mínima da coluna linear de altifalantes) e está a utilizar um ângulo de 5°, irá ocorrer quase imediatamente uma queda dos tons mais agudos.
- Uma vez que as colunas foram concebidos para direccionar o som para uma posição logo acima da cabeça dos ouvintes, recomendamos que a montagem dos altifalantes não seja feita muito acima da área de audição.
- Para determinar exactamente onde se situam os limites da área de audição no seu caso, terá que executar um teste prático no local onde está instalada a coluna linear de altifalantes. Este teste deve ser feito por um ouvinte experiente. Para isso, emita ruído rosa através da coluna linear de altifalantes. É aconselhável reduzir os sons graves para este teste, na medida em que estes não contribuem para a inteligibilidade do discurso. Ande pela área de audição e ouça os sons agudos. Os locais onde os sons agudos diminuem rapidamente são os limites da área de audição.



Figura 1 vista lateral da difusão da coluna linear de altifalantes instalada na parede com um ângulo pequeno



Figura 2 vista lateral da difusão da coluna linear de altifalantes instalada na parede com um ângulo de 5°

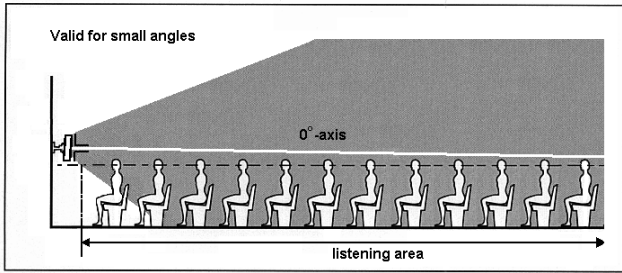

Diagrama 1: relação entre a distância da área de audição e a coluna linear de altifalantes

Relação entre área de audição e altura de instalação para XLA 3201/00

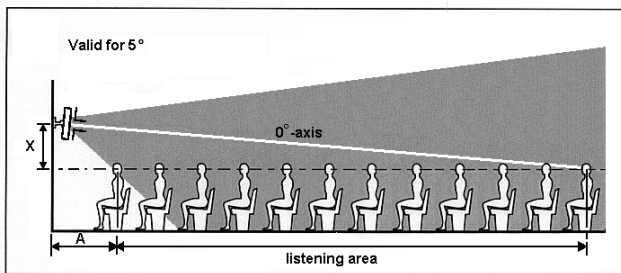
Como utilizar este método de montagem:

1. Determine as dimensões da 'área de audição' desejada (num plano horizontal ao nível dos ouvidos dos ouvintes – consulte a linha tracejada na figura 1).
2. Meça a distância máxima da coluna linear de altifalantes relativamente ao último ouvinte na área de audição (corresponde ao 'B' nas figuras 1, 2 e 3).
3. Consulte o diagrama 1 e faça uma linha para cima a partir da distância máxima no eixo horizontal. A partir da intersecção vertical com a linha diagonal B, desloque-se na horizontal até ao eixo vertical. O valor X (altura do suporte de fixação da coluna linear de altifalantes acima do plano de audição, 'X' na figura 1) está neste eixo. As intersecções horizontais com outras linhas diagonais dão informações sobre as dimensões da área de audição. Estes números estão relacionados com as figuras 2 e 3 (ver também o exemplo em baixo).
4. A figura 2 apresenta a forma da oitava de 1kHz emitida pela coluna linear de altifalantes e a figura 3 apresenta a forma da oitava de 4kHz. A área de audição com o melhor desempenho acústico encontra-se nestas formas. Certifique-se que a forma de 4kHz com as dimensões obtidas utilizando o diagrama 1 abrange de forma adequada a área de audição desejada.
5. Se a área de audição desejada for abrangida pela forma 4kHz, o valor X no eixo vertical mostra a que altura a coluna linear de altifalantes deve ser instalada acima do plano de audição. Lembre-se que a coluna linear de altifalantes deve ser instalada num ângulo de 8° relativamente à altura escolhida!

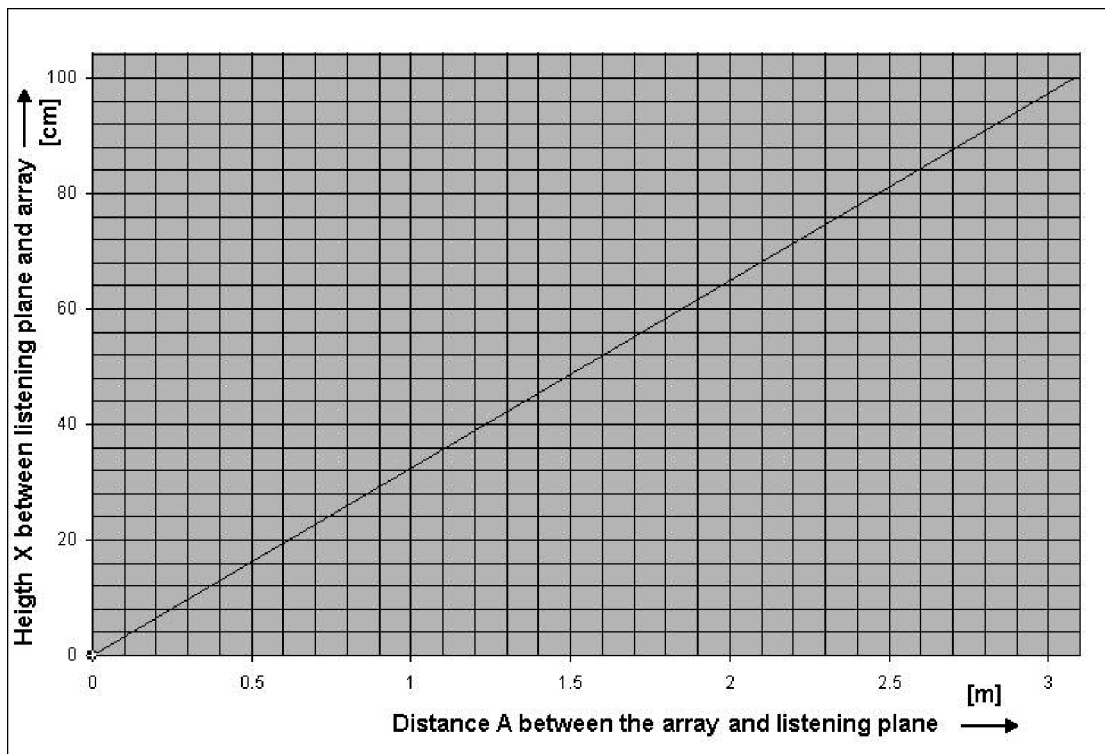
Agora pode instalar a coluna linear de altifalantes para obter o melhor desempenho acústico

Exemplo:

A distância máxima da coluna linear de altifalantes até ao último ouvinte é de 15m. Marcando uma linha para cima a partir do ponto de 15m no eixo horizontal do diagrama 1 para a linha diagonal B e, em seguida, para o lado em direcção ao eixo vertical, as intersecções com as outras linhas diagonais dão-nos as dimensões dos planos de audição. Neste exemplo:

Linha F (comprimento lateral do plano de audição de 4kHz) = 11,1m

Linha C (comprimento do plano de audição) = 11m

Linha E (plano de audição a meia largura de 4kHz) = 9,3m

Linha A (distância mínima do plano de audição) = 3,9m

No eixo vertical, o valor X (a altura entre o plano de audição e o suporte de montagem da coluna linear de altifalantes) é 1,8m.

Perguntas e respostas sobre a instalação:

- **A área de audição desejada é demasiado grande e não cabe na forma de 4kHz.**
Tente colocar o suporte de fixação da coluna linear de altifalantes a outra altura, ou utilize mais colunas para obter uma área de audição maior.
- **Porquê utilizar um ângulo de 8° para a coluna linear de altifalantes?**
As formas de difusão apresentadas nas figuras 2 e 3 com as dimensões do diagrama 1 são válidas apenas quando a coluna linear de altifalantes é instalada num ângulo de 8°. Apenas nesta situação se obtém um nível de pressão sonora e uma resposta de frequência constantes (directividade constante) na área de audição.
- **Posso utilizar a coluna de altifalantes nouro ângulo?**
Sim, mas não irá obter o melhor desempenho acústico. Por exemplo, será audível uma variação do nível de pressão sonora maior na área de audição. Os valores no diagrama 1 não são válidos para outros ângulos. Não é recomendada a utilização de um ângulo superior a 8°.
- **A coluna linear de altifalantes não pode ser instalada a uma altura qualquer.**
Se a altura do tecto não permitir obter a altura necessária, deve utilizar um ângulo inferior a 8°. Direcione o eixo 00 da coluna linear de altifalantes para a posição máxima desejada (ver figura 4). Lembre-se que a tabela no diagrama 1 e as formas nas figuras 2 e 3 não são válidas para esta situação. Verifique na área de audição se a inteligibilidade do discurso é aceitável.

Informação básica:

- As formas são definidas num ambiente anecóico. Com estas formas num ambiente anecóico, obtém uma variação de pressão sonora máxima de 6dB e uma variação da resposta de frequência muito menor. Em áreas com reverberação normal ou elevada, existe menor variação do nível de pressão sonora e o tamanho das formas será maior. A resposta de frequência obtida nesta forma será quase constante.
- Quando se afasta da posição máxima da área de audição (para além da distância máxima da coluna linear de altifalantes) apenas o nível de pressão sonora irá diminuir. Quase não existe variação na tonalidade. A diminuição do nível de pressão sonora depende em grande parte da reverberação do compartimento.
- Quando se aproxima demasiado da coluna linear de altifalantes (menos que a distância mínima relativamente á coluna) ocorrerá quase imediatamente uma perda de sons agudos.

- Dependendo do nível de reverberação no compartimento e da 'sombra' do som (pessoas ou objectos à frente do ouvinte a bloquearem a fonte directa de som), a inteligibilidade do discurso nas posições mais afastadas poderá ser menor. Nestas situações, será conveniente utilizar mais colunas para ampliar a área de audição.
- As linhas laterais das formas das figuras 2 e 3 são os pontos -6dB relacionados com o nível de pressão sonora no eixo 00.
- Para obter a melhor inteligibilidade do discurso, defina uma área de audição na qual a forma da oitava de 4kHz abranja toda a área.
- Para determinar exactamente onde se situam os limites da área de audição no seu caso, terá que executar um teste prático no local onde está instalado a coluna linear de altifalantes. Este teste deve ser feito por um ouvinte experiente. Para isso, emita ruído rosa através da coluna linear de altifalantes. É aconselhável reduzir os sons graves para este teste, na medida em que estes não contribuem para a inteligibilidade do discurso. Ande pela área de audição e ouça os sons agudos. Os locais onde os sons agudos diminuem rapidamente são os limites da área de audição.



Diagrama 1: relação entre a área de audição e a altura de instalação da coluna linear de altifalantes

Significado das linhas diagonais

Linha B: distância máxima da coluna linear e altifalantes até ao último ouvinte.

Linha D: plano de distância a meia largura a 1kHz

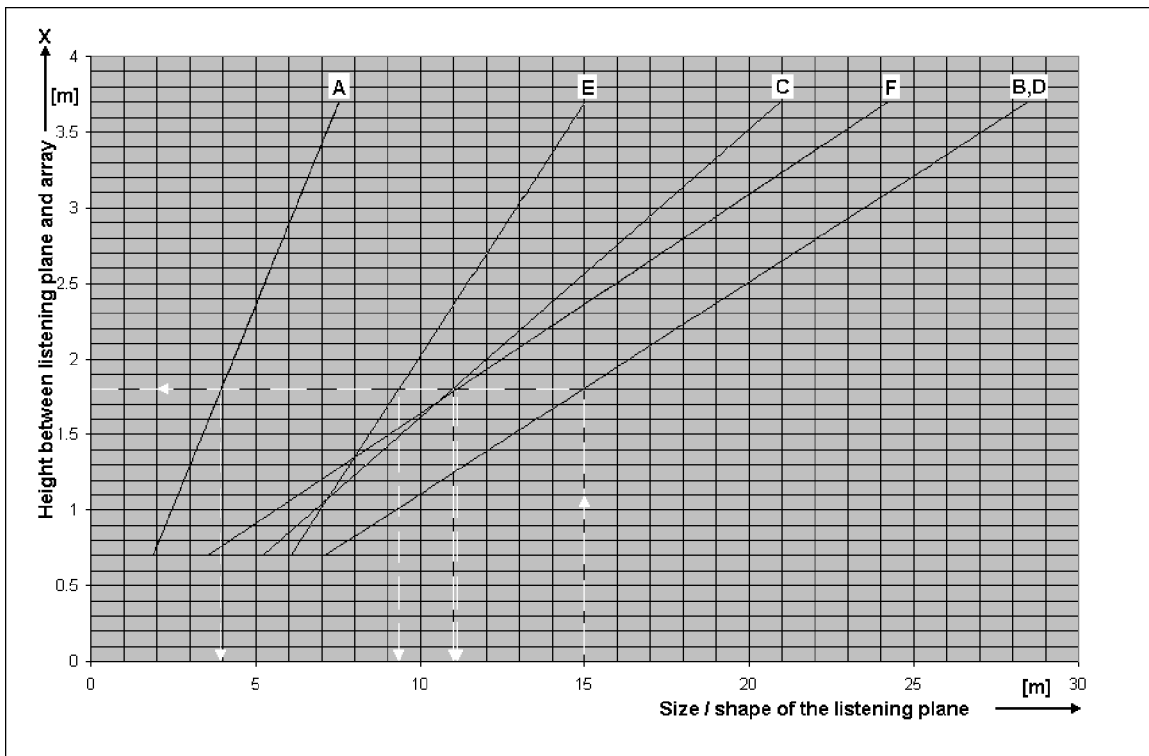
Linha F: comprimento lateral do plano de audição a 4kHz

Linha C: comprimento do plano de audição

Linha E: plano de audição a meia largura a 4kHz

Linha A: distância mínima para o plano de audição



Figura 1: vista lateral da difusão da coluna linear de altifalantes e do plano de audição



Figura 2: forma da oitava de 1kHz da coluna linear de altifalantes

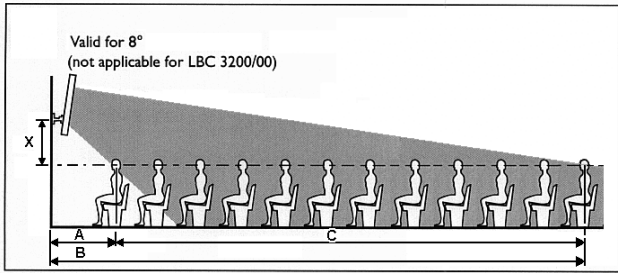

Figura 3: forma da oitava de 4kHz da coluna linear de altifalantes

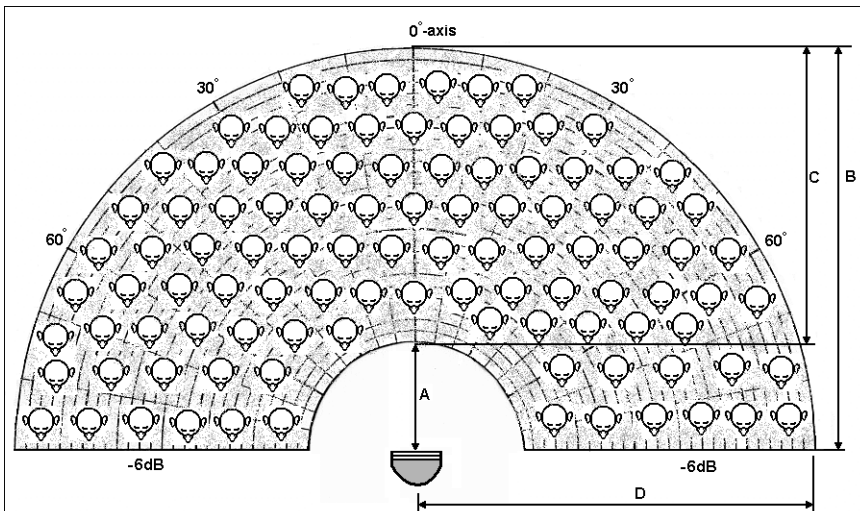

Figura 4: Direcção do eixo 0° da coluna linear de altifalantes para a posição máxima

Relação entre área de audição e altura de instalação para XLA 3210/00

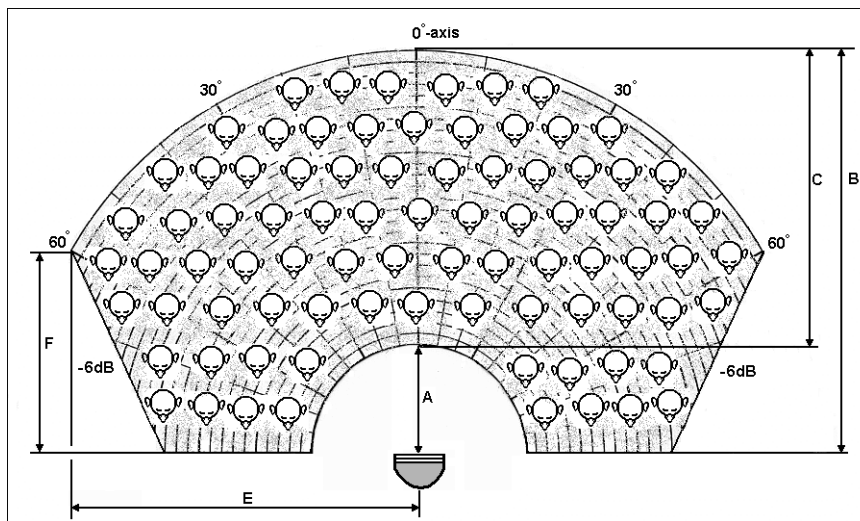
Como utilizar este método de instalação:

1. Determine as dimensões da 'área de audição' desejada (num plano horizontal ao nível dos ouvidos dos ouvintes – consulte a linha tracejada na figura 1).
2. Meça a distância máxima da coluna linear de altifalantes relativamente ao último ouvinte na área de audição (corresponde ao 'B' nas figuras 1, 2 e 3).
3. Consulte o diagrama 1 e faça uma linha para cima a partir da distância máxima no eixo horizontal. A partir da intersecção vertical com a linha diagonal B, desloque-se na horizontal até ao eixo vertical. O valor X (altura do suporte de fixação da coluna linear de altifalantes acima do plano de audição, 'X' na figura 1) está neste eixo. As intersecções horizontais com outras linhas diagonais dão informações sobre as dimensões da área de audição. Estes números estão relacionados com as figuras 2 e 3 (ver também o exemplo em baixo).
4. A figura 2 apresenta a forma da oitava de 1kHz emitida pela coluna linear de altifalantes e a figura 3 apresenta a forma da oitava 4kHz. A área de audição com o melhor desempenho acústico encontra-se nestas formas. Certifique-se que a forma de 4kHz com as dimensões obtidas utilizando o diagrama 1 abrange de forma adequada a área de audição desejada.
5. Se a área de audição desejada for abrangida pela forma 4kHz, o valor X no eixo vertical mostra a que altura da coluna linear de altifalantes deve ser instalada acima do plano de audição. Lembre-se que a coluna linear de altifalantes deve ser instalada num ângulo de 8° relativamente à altura escolhida!

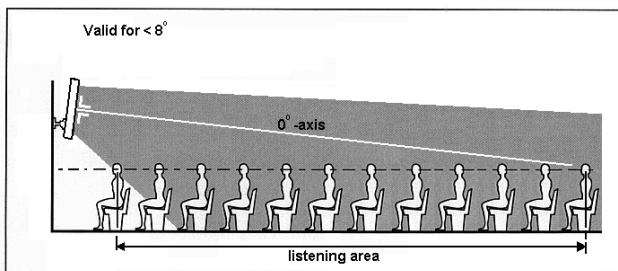
Agora pode instalar a coluna linear de altifalantes para obter o melhor desempenho acústico .

Exemplo do diagrama:

A distância máxima da coluna linear de altifalantes até ao último ouvinte é de 15m. Marcando uma linha para cima a partir do ponto de 15m no eixo horizontal do diagrama 1 para a linha diagonal B e, em seguida, para o lado em direcção ao eixo vertical, as intersecções com as outras linhas diagonais dão-nos as dimensões dos planos de audição. Neste exemplo:

Linha F (comprimento lateral do plano de audição a 4kHz) = 12,2m

Linha C (comprimento do plano de audição) = 11m

Linha E (plano de audição a meia largura a 4kHz) = 8,6m

Linha A (distância mínima do plano de audição) = 3,9m

No eixo vertical, o valor X (a altura entre o plano de audição e o suporte de fixação da coluna linear de altifalantes) é 1,8m.

Perguntas e respostas sobre a instalação:

- **A área de audição desejada é demasiado grande e não encaixa na forma de 4kHz.**

Tente colocar o suporte de fixação da coluna linear de altifalantes a outra altura, ou utilize mais colunas para obter uma área de audição maior.

- **Porquê utilizar um ângulo de 8° para a coluna linear de altifalantes?**

As formas de difusão apresentadas nas figuras 2 e 3 com as dimensões do diagrama 1 são válidas apenas quando a coluna linear de altifalantes é instalada num ângulo de 8°. Apenas nesta situação se obtém um nível de pressão sonora e uma resposta de frequência constantes (directividade constante) na área de audição.

- **Posso utilizar a coluna linear de altifalantes noutro ângulo?**

Sim, mas não irá obter um desempenho acústico optimizado. Por exemplo, será audível uma variação do nível de pressão sonora maior na área de audição. Os valores no diagrama 1 não são válidos para outros ângulos. Não é recomendada a utilização de um ângulo superior a 8°.

- **A coluna linear de altifalantes não pode ser instalada a uma altura qualquer.**

Se a altura do tecto não permitir obter a altura necessária, deve utilizar um ângulo inferior a 8°.

Direccione o eixo 00 da coluna linear de altifalantes para a posição máxima desejada (ver figura 4). Lembre-se que a tabela no diagrama 1 e as formas nas figuras 2 e 3 não são válidas para esta situação. Verifique se na área de audição a inteligibilidade do discurso é aceitável, assim como a audição de mensagens.

Informação básica:

- As formas são definidas num ambiente anecóico. Com estas formas num ambiente anecóico, obtém-se uma variação de pressão sonora máxima de 6dB e uma variação da resposta de frequência muito menor. Em áreas com reverberação normal ou elevada, existe menor variação do nível de pressão sonora e o tamanho das formas será maior. A resposta de frequência obtida nesta forma será quase constante.
- Quando se afasta da posição máxima da área de audição (para além da distância máxima da coluna linear de altifalantes) apenas o nível de pressão sonora irá diminuir. Quase não existe variação na tonalidade. A diminuição do nível de pressão sonora depende em grande parte da reverberação do compartimento.
- Quando se aproxima demasiado da coluna linear de altifalantes (menos que a distância mínima relativamente á coluna) ocorrerá quase imediatamente uma perda de sons agudos.
- Dependendo do nível de reverberação no compartimento e da 'sombra' do som (pessoas ou objectos à frente do ouvinte a bloquearem a fonte

directa de som), a inteligibilidade do discurso nas posições mais afastadas poderá ser menor. Nestas situações, será mais conveniente utilizar mais colunas para ampliar a área de audição.

- As linhas laterais das formas das figuras 2 e 3 são os pontos -6dB relacionados com o nível de pressão sonora no eixo 0°.
- Para obter a melhor inteligibilidade do discurso, defina uma área de audição na qual a forma da oitava de 4kHz abranja toda a área.
Para determinar exactamente onde se situam os limites da área de audição no seu caso, terá que executar um teste prático no local onde está instalado a coluna linear de altifalantes. Este teste deve ser feito por um ouvinte experiente. Para isso, emita ruído rosa através do conjunto de altifalantes. É aconselhável reduzir os sons graves para este teste, na medida em que estes não contribuem para a inteligibilidade do discurso. Ande pela área de audição e ouça os sons agudos. Os locais onde os sons agudos diminuem rapidamente são os limites da área de audição.



Diagrama 1: relação entre a área de audição e a altura de instalação da coluna linear de altifalantes

Significado das linhas

Linha B: distância máxima da coluna linear de altifalantes até ao último ouvinte.

Linha D: plano de distância a meia largura a 1kHz

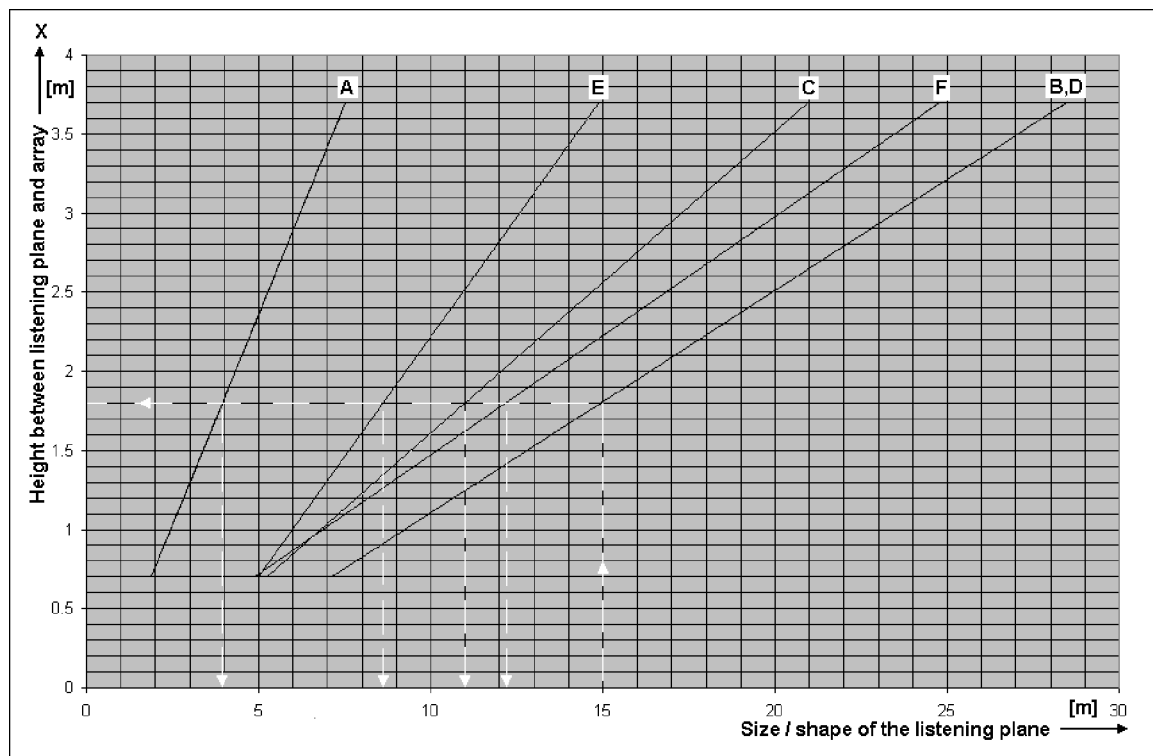
Linha F: comprimento lateral do plano de audição a 4kHz

Linha C: comprimento do plano de audição

Linha E: plano de audição a meia largura a 4kHz

Linha A: distância mínima para o plano de audição



Figura 1: vista lateral da difusão da coluna linear de altifalantes e do plano de audição



Figura 2: forma da oitava de 1kHz da coluna linear de altifalantes

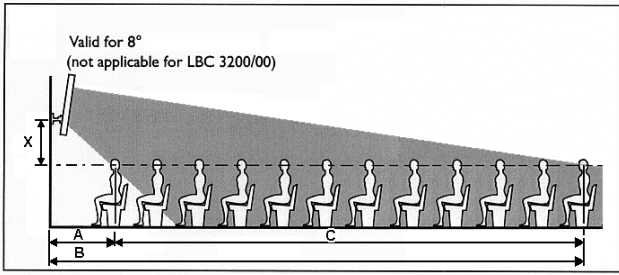

Figura 3: forma da oitava 4 de kHz da coluna linear de altifalantes

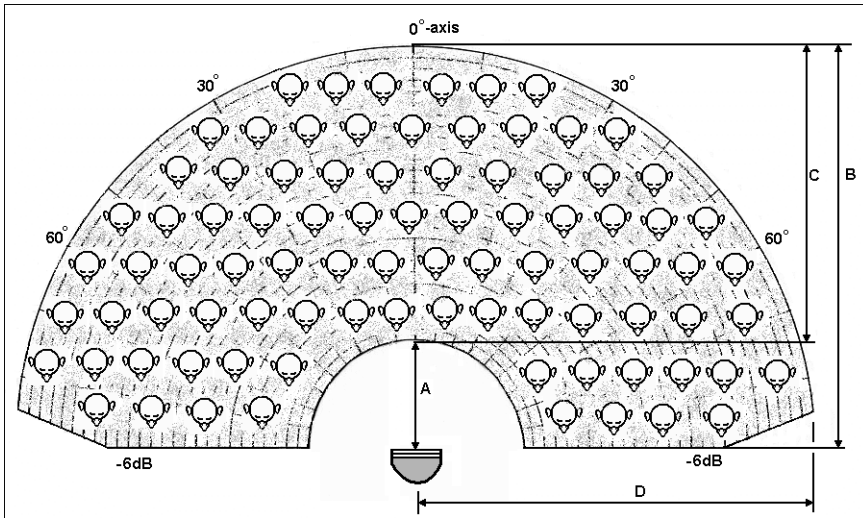

Figura 4: Direcção do eixo 0° da coluna linear de altifalantes para a posição máxima

DADOS TÉCNICOS DE DESEMPENHO**LBC 3200/00**

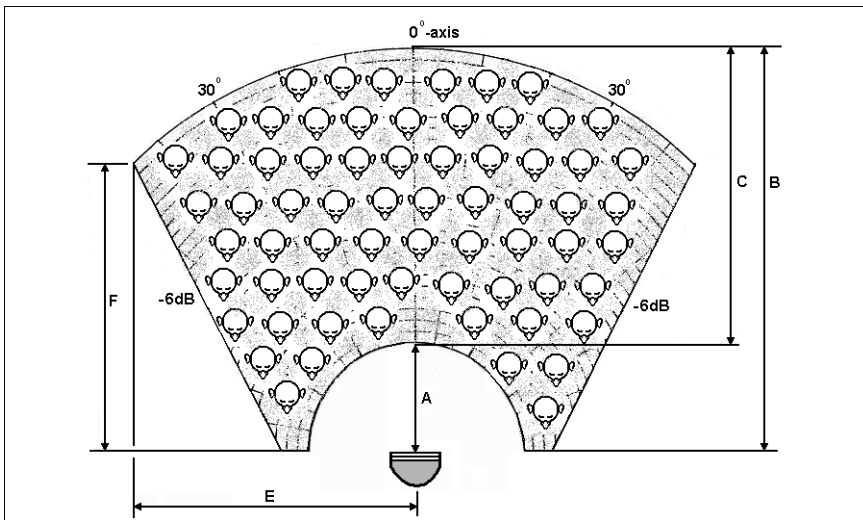
Potência máxima	45 W
Potência nominal	30 W (30-15-7,5 W)
Nível de pressão sonora a	
30 W/1 W (a 1 kHz, 1 m)	106 dB/91 dB (SPL)
Gama de frequências efectiva (-10 dB)	de 190 Hz a 18 kHz
Ângulo de abertura	
(a 1 kHz/4 kHz, -6 dB)	
Horizontal	220° /130°
Vertical	70° /18°
Tensão nominal de entrada	100 V
Impedância nominal	333 ohm
Intervalo de temperatura ambiente	de -25°C a +55°C
Segurança	em conformidade com EN 60065
Ligação	terminal de parafusos
Dimensões (A x L x P)	600 x 80 x 90 mm
Cor	prateado
Peso	3 kg

**LBC 3200/00**

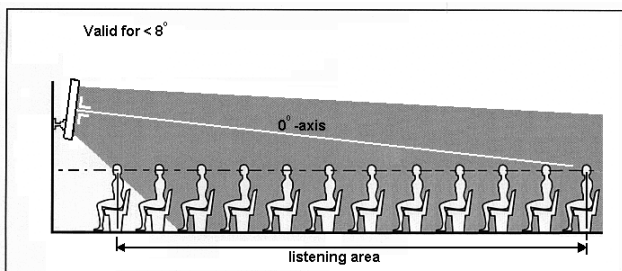
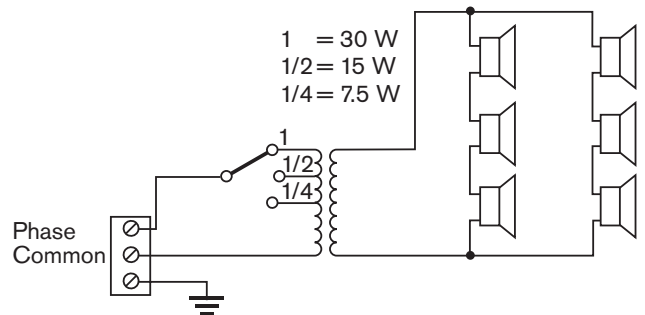
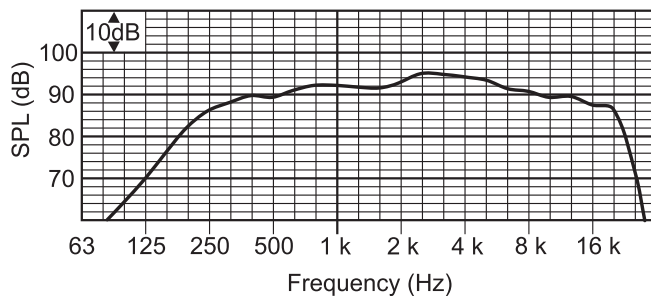
Banda de oitavas (Hz)	250	500	1 k	2 k	4 k	8 k
SPL 1.1	87	89	91	93	93	89
SPL máx.	102	104	106	108	108	104
Factor Q	1,3	2,2	4,5	11,6	25,7	58,9
Ângulo horizontal (graus)	360	360	220	190	130	100
Ângulo vertical (graus)	360	120	70	32	18	10

Horizontal

Vertical

LBC 3200/00
250Hz horizontal

LBC 3200/00
250Hz vertical

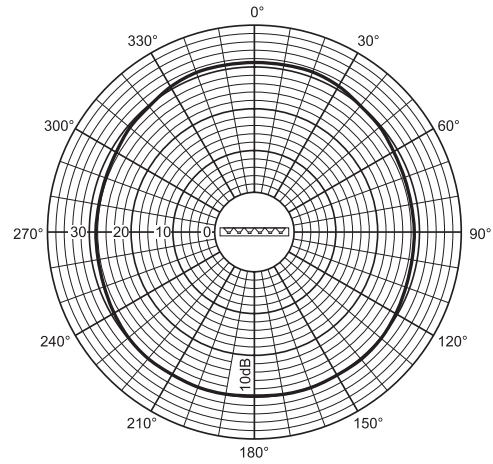
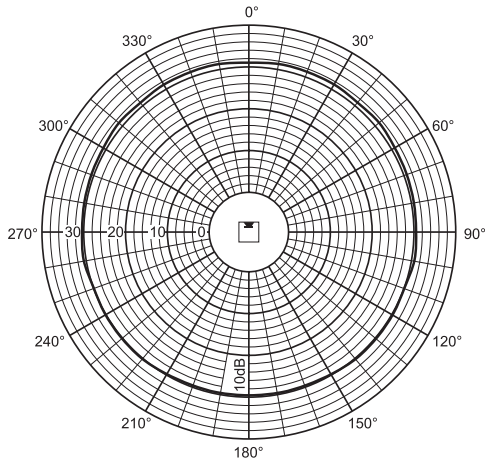

LBC 3200/00
500Hz horizontal

LBC 3200/00
500Hz vertical

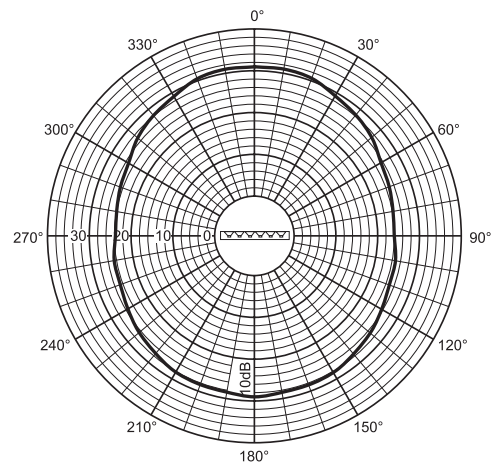
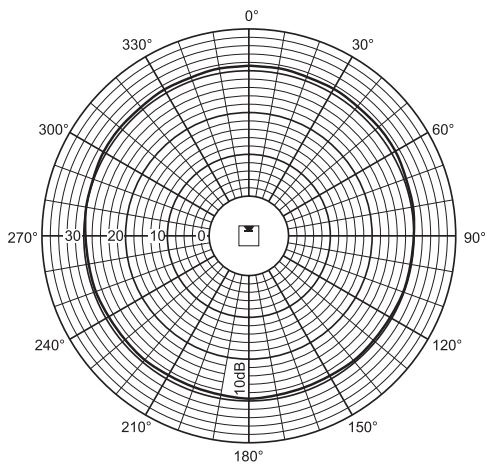

LBC 3200/00
1kHz horizontal

LBC 3200/00
1kHz vertical

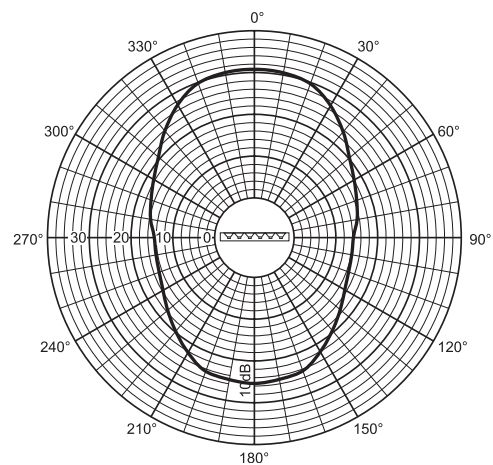
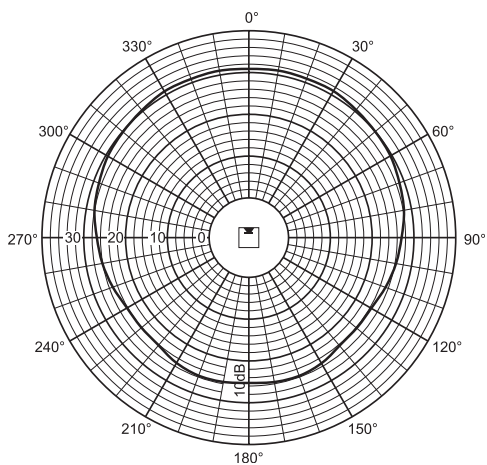

Horizontal

Vertical

LBC 3200/00
2kHz horizontal

LBC 3200/00
2kHz vertical

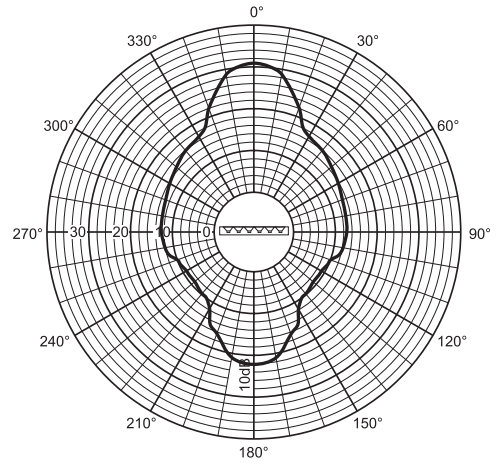
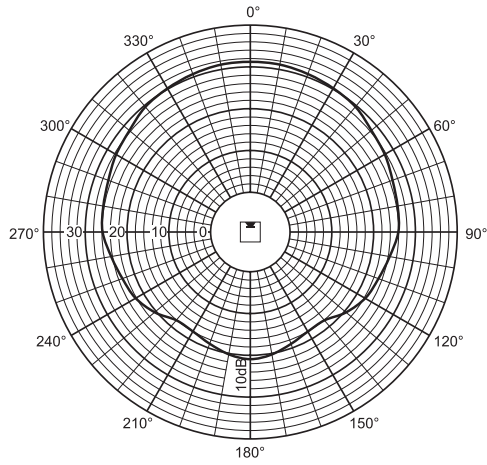

LBC 3200/00
4kHz horizontal

LBC 3200/00
4kHz vertical

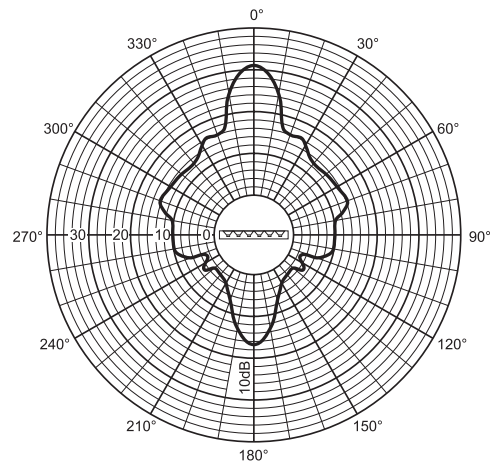
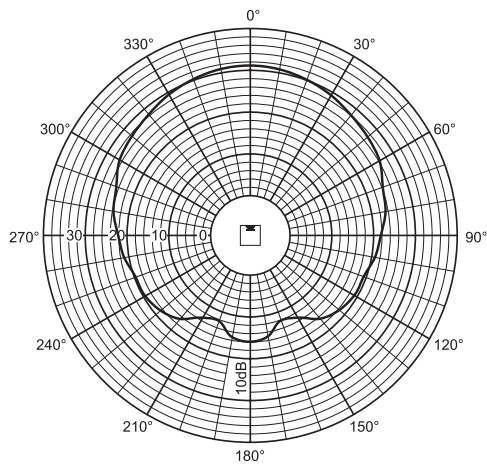

LBC 3200/00
8kHz horizontal

LBC 3200/00
8kHz vertical

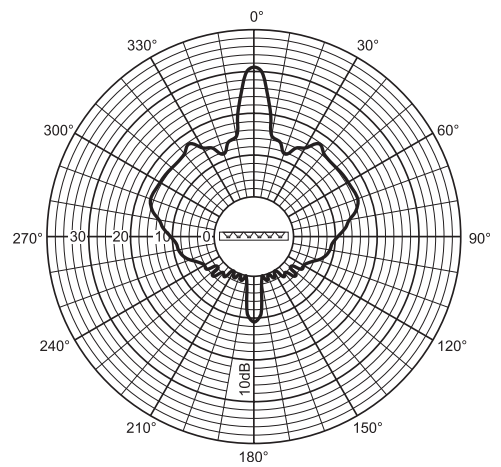
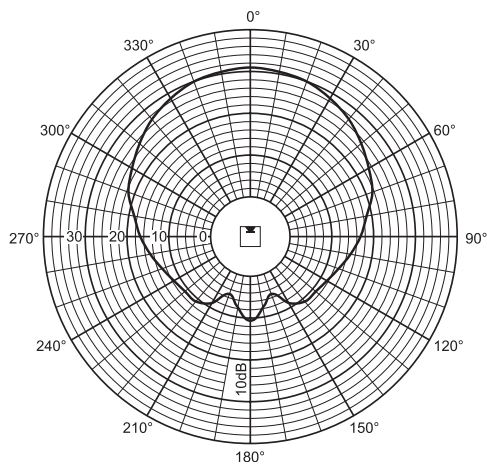

DADOS TÉCNICOS DE DESEMPENHO**LBC 3201/00**

Potência máxima	90 W
Potência nominal	60 W (60-30-15 W)
Nível de pressão sonora a	
60 W/1 W (a 1 kHz, 1 m)	110 dB/92 dB (SPL)
Gama de frequências efectiva (-10 dB)	de 190 Hz a 18 kHz
Ângulo de abertura	
(a 1 kHz / 4 kHz, - 6 dB)	
Horizontal	210°/132°
Vertical	50°/22°
Tensão nominal de entrada	100 V
Impedância nominal	167 ohm
Intervalo de temperatura ambiente	de -25°C a +55°C
Segurança	em conformidade com EN 60065.
Ligação	terminal de parafusos
Dimensões (A x L x P)	1200 x 80 x 90 mm
Cor	prateado
Peso	6,4 kg

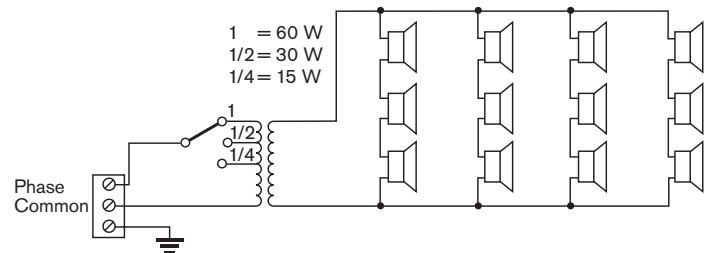
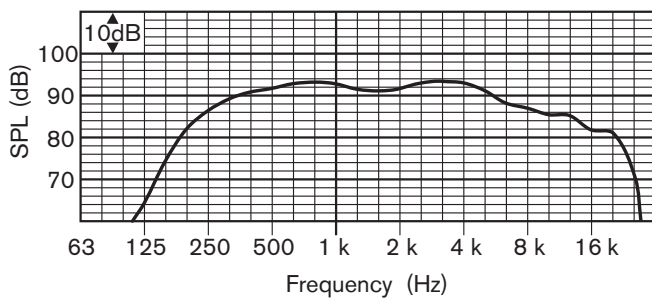
**LBC 3201/00**

Banda de oitavas (Hz)	250	500	1 k	2 k	4 k	8 k
SPL 1.1	88	92	92	91	91	86
SPL máx.	106	110	110	109	109	104
Factor Q	2,2	3,2	6,5	12,6	23,4	53,3
Ângulo horizontal (graus)	360	360	210	192	132	100
Ângulo vertical (graus)	107	67	50	33	22	12

Horizontal

Vertical

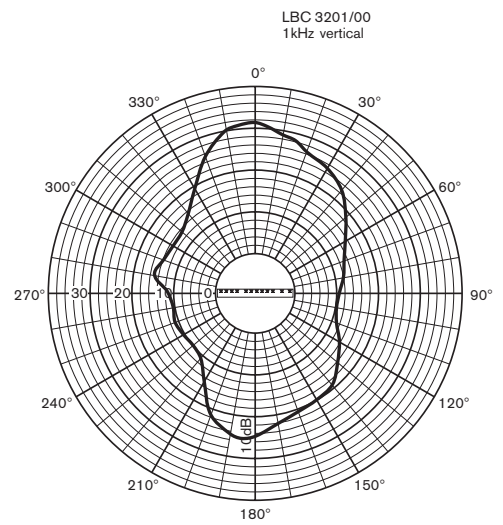
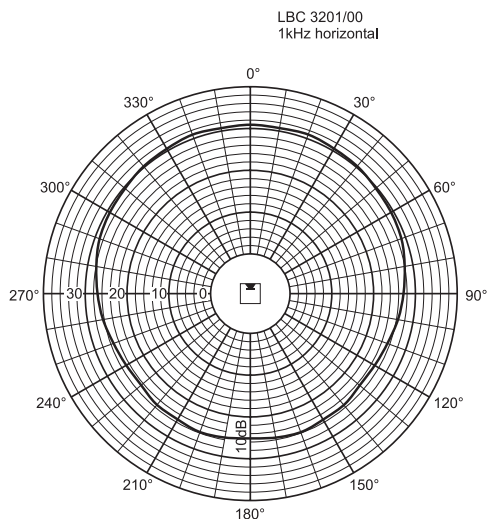
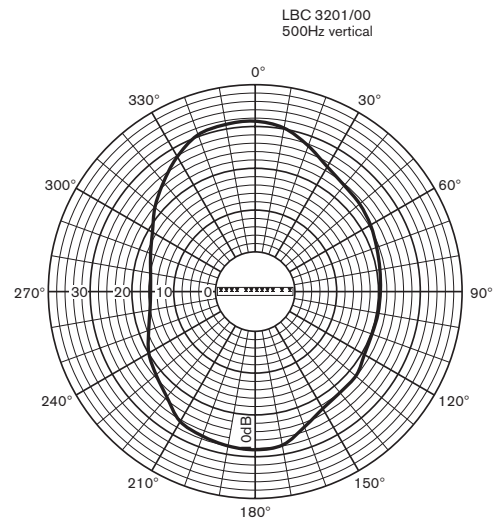
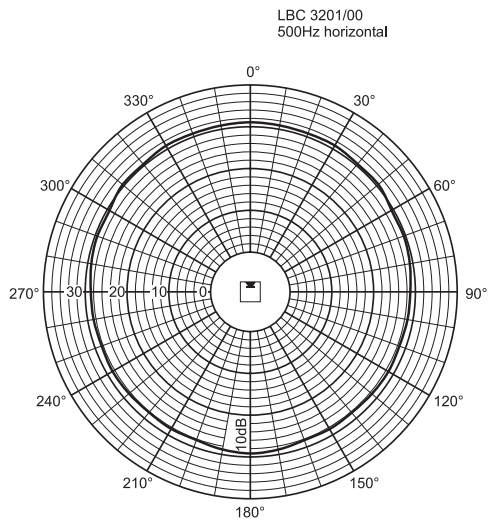
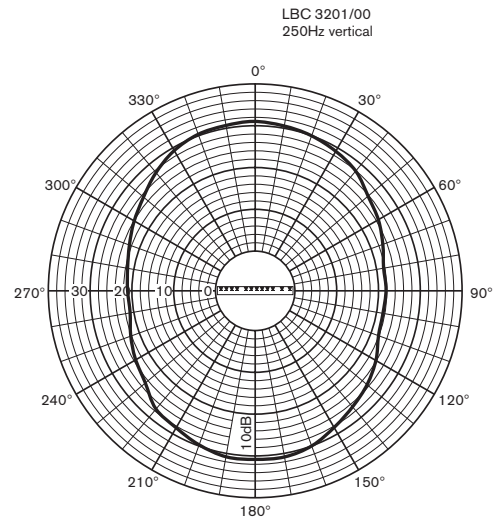
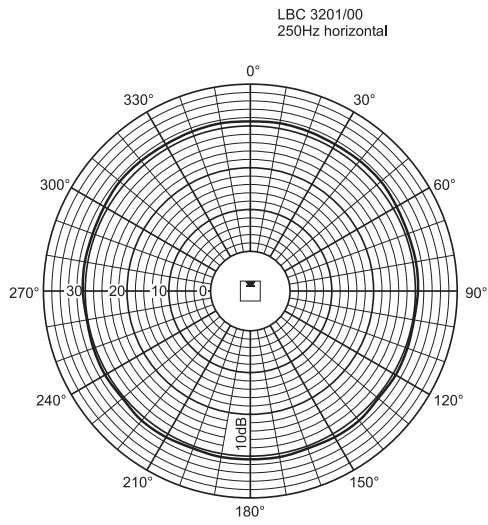

Horizontal

Vertical

LBC 3201/00
2kHz horizontal

LBC 3201/00
2kHz vertical

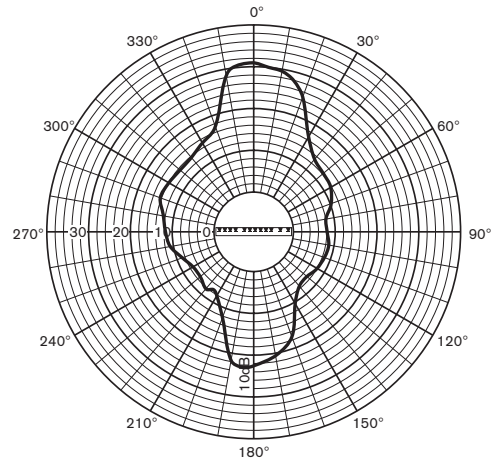
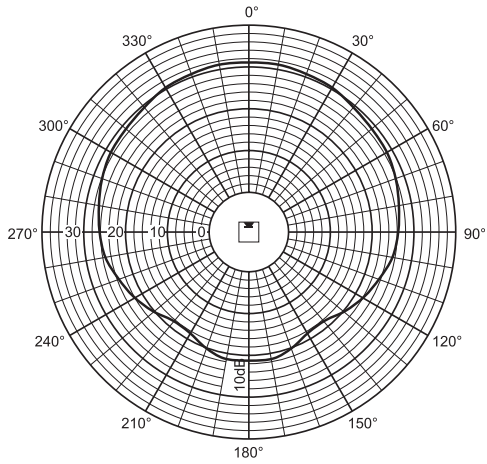

LBC 3201/00
4kHz horizontal

LBC 3201/00
4kHz vertical

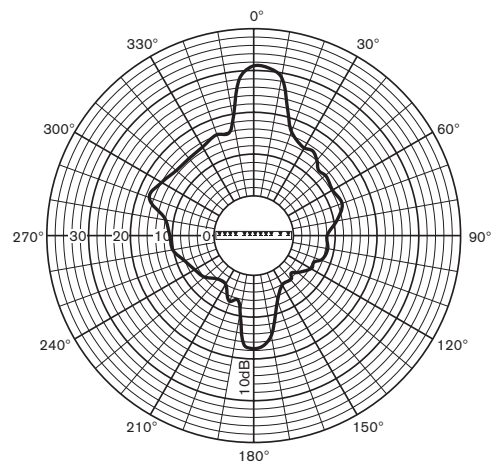
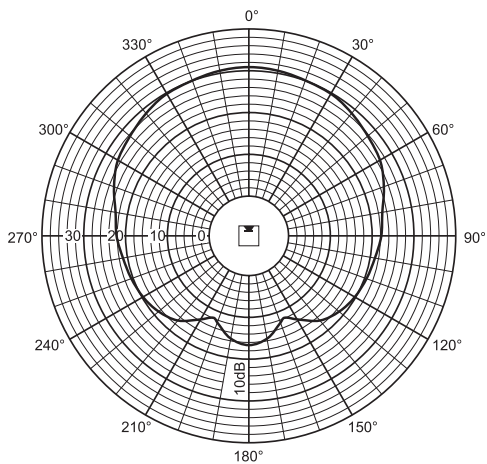

LBC 3201/00
8kHz horizontal

LBC 3201/00
8kHz vertical

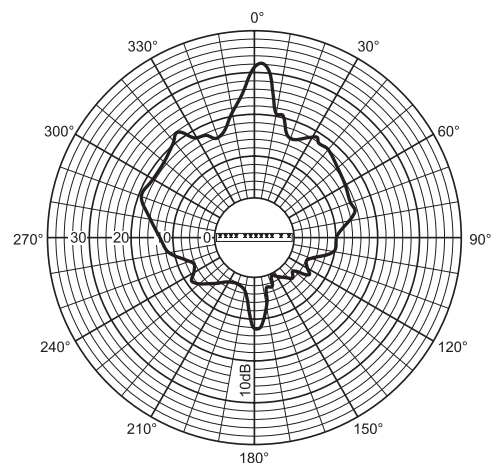
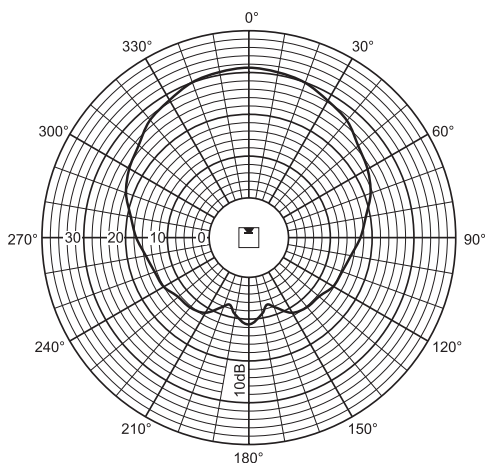

DADOS TÉCNICOS DE DESEMPENHO**LBC 3210/00**

Potência máxima	90 W
Potência nominal	60 W (60-30-15 W)
Nível de pressão sonora	
a 60 W/1 W (a 1 kHz, 1 m)	115 dB/97 dB (SPL)
Gama de frequências efectiva (-10 dB)	de 190 Hz a 20 kHz
Ângulo de abertura	
(a 1 kHz / 4 kHz, - 6 dB)	
Horizontal	170°/90°
Vertical	55°/18°
Tensão nominal de entrada	100 V
Impedância nominal	167 ohm
Intervalo de temperatura ambiente	de -25°C a +55°C
Segurança	em conformidade com EN 60065.
Protecção contra água/poeiras	IP 66 em conformidade com IEC 60529
Ligação	terminal de parafusos
Dimensões (A x L x P)	1200 x 160 x 90 mm
Cor	prateado
Peso	9 kg

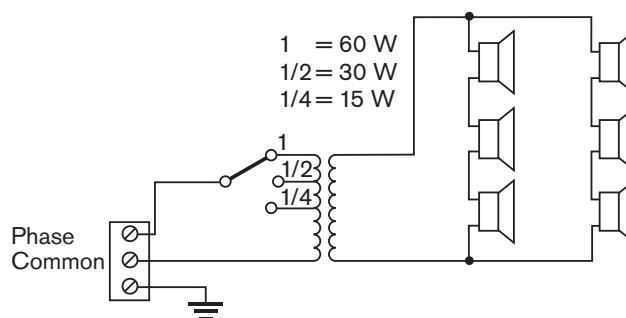
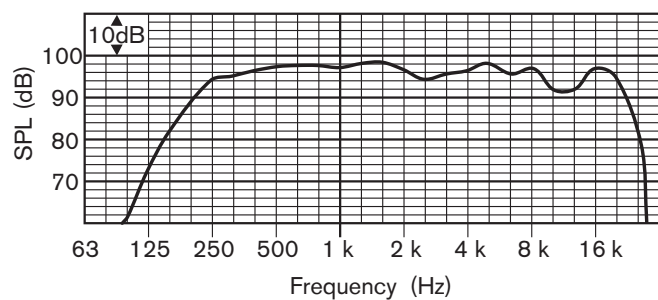
**LBC 3210/00**

Banda de oitavas (Hz)	250	500	1 k	2 k	4 k	8 k
SPL 1.1	94	97	97	95	96	93
SPL máx.	112	115	115	113	114	111
Factor Q	2,2	2,7	6,3	10,8	22,6	32,3
Ângulo horizontal (graus)	360	180	170	160	90	60
Ângulo vertical (graus)	100	60	55	34	18	10

Horizontal

Vertical

LBC 3210/00
250Hz horizontal

LBC 3210/00
250Hz vertical

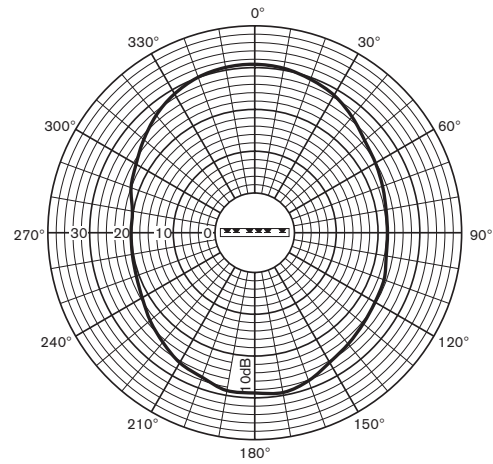
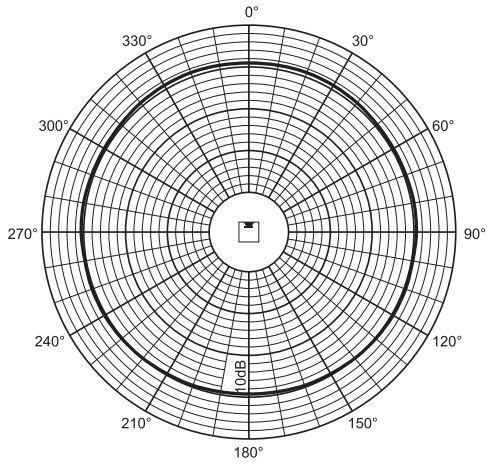

LBC 3210/00
500Hz horizontal

LBC 3210/00
500Hz vertical

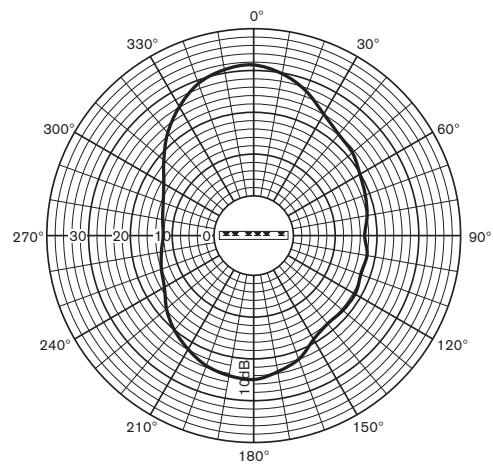
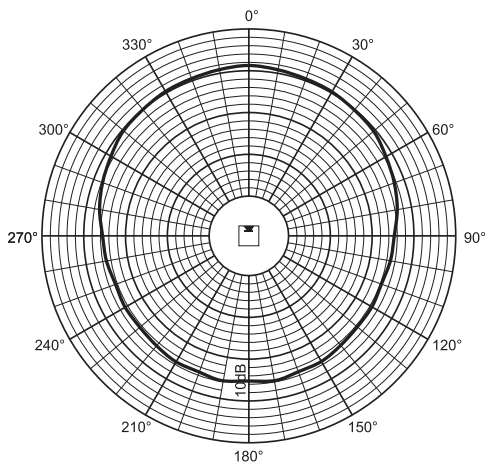

LBC 3210/00
1kHz horizontal

LBC 3210/00
1kHz vertical

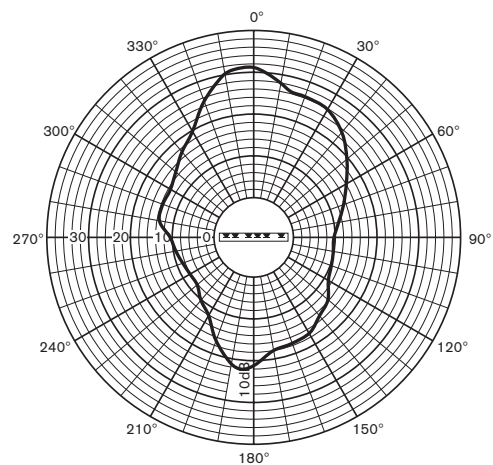
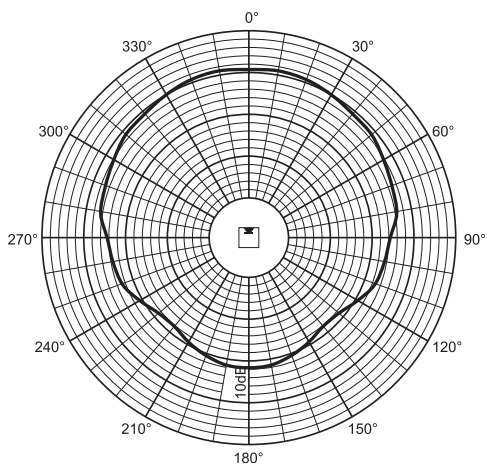

Horizontal

Vertical

LBC 3210/00
2kHz horizontal

LBC 3210/00
2kHz vertical

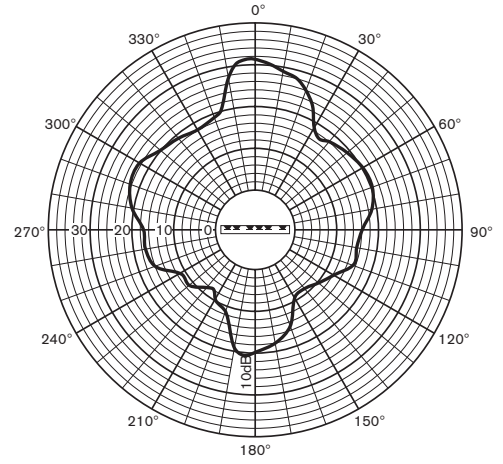
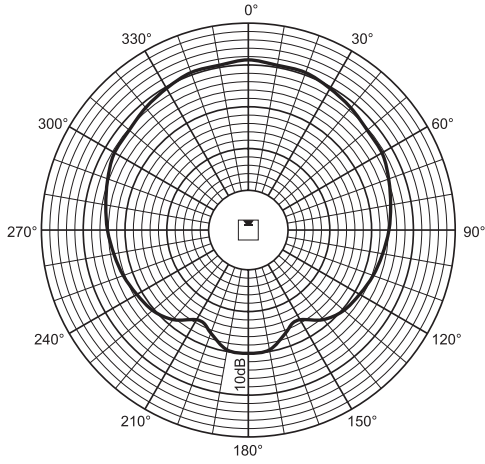

LBC 3210/00
4kHz horizontal

LBC 3210/00
4kHz vertical

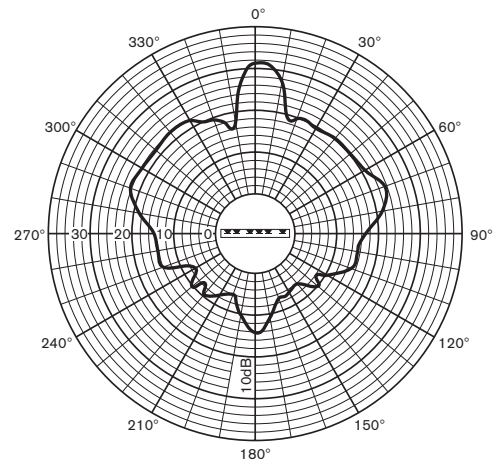
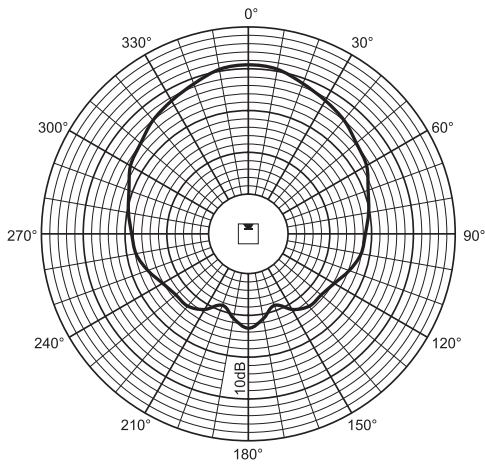

LBC 3210/00
8kHz horizontal

LBC 3210/00
8kHz vertical

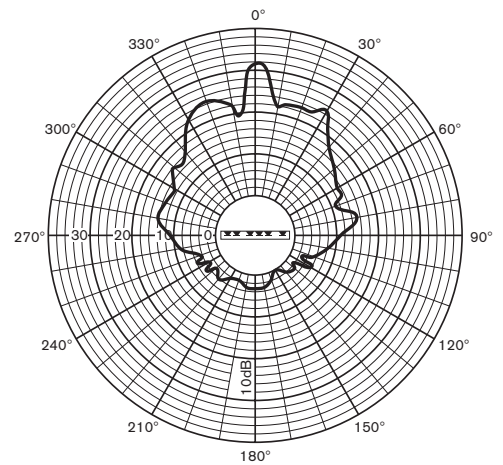
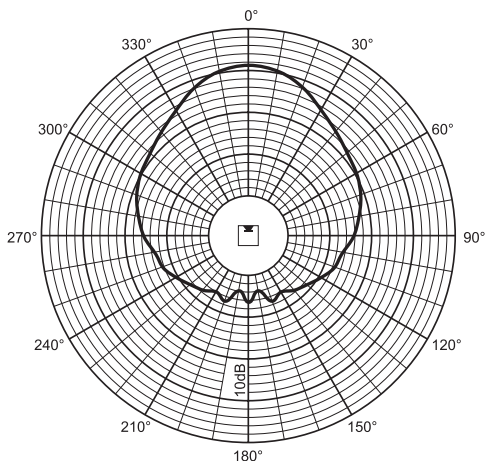

www.boschsecuritysystems.com

BOSCH

www.boschsecuritysystems.com

BOSCH

Free Manuals Download Website

<http://myh66.com>

<http://usermanuals.us>

<http://www.somanuals.com>

<http://www.4manuals.cc>

<http://www.manual-lib.com>

<http://www.404manual.com>

<http://www.luxmanual.com>

<http://aubethermostatmanual.com>

Golf course search by state

<http://golfingnear.com>

Email search by domain

<http://emailbydomain.com>

Auto manuals search

<http://auto.somanuals.com>

TV manuals search

<http://tv.somanuals.com>