

6159939020



# **SD25 Series Electric Screwdrivers**

## **User's Manual**

CP Ref. / N° : 6159939020  
Techmotive P/N : 39-30-40409

**DECEMBER 2005**



**24-Hour  
Technical Support  
Toll Free in the U.S. and Canada:  
1-877-224-7377**

**All other countries:  
(001) 248-348-6280  
between 8 a.m. and 5 p.m.  
Eastern Standard Time (EST)**

NOTE: Chicago Pneumatic Tool Company (CP) in 2005 acquired and changed the name of GSE tech-motive tool to CP Techmotive. Product Information may be found on [www.cp.com](http://www.cp.com).

NOTE: The part number for the Visual Supervisor (VS) software program is 464000-03330 (CP part number 6150040915)

NOTE: A variety of related **technical manuals** in .pdf format may be downloaded from [www.cp.com](http://www.cp.com). Click on **the Technical Info link** on the left column. Select *Technical Documentation*. Scroll through the list to find the title of the product you require, and click!

CP Techmotive manufactures products under the CP, CP Techmotive, and *tech-motive tool*<sup>®</sup> brand names

Information and technical diagrams in this manual are subject to change without notice. *techmotive tool* is a registered trademark. Products and services referred to in this book may be either trademarks and/or registered trademarks of their respective owners.

## LIMITED WARRANTY

CP Techmotive warrants its PRODUCTS to be free from defects in materials and workmanship for the lesser of (1) one year from the date of shipment from the manufacturing facility in Michigan, U.S.A. OR (2) one-million cycles except for the products noted below:

CP Techmotive crowfoot, tubenut and hold & drive heads	250,000 cycles
3 <sup>rd</sup> -party crowfoot, tubenut, hold-and-drive torque multiplier or other heads	manufacturer's warranty
56 and 116 Series nutrunners	500,000 cycles

PRODUCTS include CP Techmotive brand fastening tools, controllers and cables, GSE brand sensors and instruments, and anti-lock brake testing systems. Fuses and batteries are not covered under warranty.

For PRODUCTS verified as defective at CP Techmotive's manufacturing facility, CP Techmotive shall have the option, in its sole discretion, to repair or replace the products or components. CP Techmotive shall not be liable for any installation charges, expenses of the Buyer for repairs or replacement, damages from delay or loss of use, or other indirect or consequential damages of any kind. The warranty does not cover any product that has been modified without the approval of CP Techmotive, used for a purpose other than that for which it was intended, used in a manner inconsistent with any instructions, subjected to unusual physical stress, environmental or electrical conditions, or whose original identification marks have been removed or altered.

Whenever the PRODUCTS are to be incorporated in a system, the design of which originated with the Buyer, CP Techmotive only that the PRODUCTS shall be free of defects in materials and workmanship and offers no other warranty.

In the event that a product is repaired or replaced under the terms of the warranty, the warranty period for the repaired or replacement product shall be limited to the remaining portion of the original warranty.

Any warranty extended by the original manufacturer of peripheral equipment, such as printers, recorders, plotters, etc., included with a CP Techmotive product or system shall be extended to the Buyer and shall be the only warranty offered.

Transportation charges for materials shipped to the manufacturing facility for warranty repair are to be paid by the Buyer. CP Techmotive will pay for shipping to return items repaired or replaced under warranty.

THIS LIMITED WARRANTY IS EXCLUSIVE, AND CP Techmotive MAKES NO OTHER WARRANTY OF ANY KIND WHATSOEVER, WHETHER EXPRESSED, IMPLIED OR STATUTORY, WITH RESPECT TO THE PRODUCTS OR PARTS MANUFACTURED BY IT, WHETHER AS TO MERCHANTABILITY, FITNESS FOR A PARTICULAR PURPOSE OR ANY OTHER MATTER OR WARRANTY OF ANY KIND. No agent, employee or representative of CP Techmotive has the authority to bind CP Techmotive in any affirmation, representation, or warranty concerning the Products or parts except as stated herein.

THIS REMEDY SHALL BE THE EXCLUSIVE REMEDY AVAILABLE FOR ANY NONCONFORMITIES IN MATERIALS OR WORKMANSHIP, OR FOR ANY DAMAGES RESULTING FROM ANY OTHER CAUSE WHATSOEVER. CP Techmotive SHALL NOT, IN ANY EVENT, BE LIABLE FOR ANY SPECIAL, INDIRECT, INCIDENTAL OR CONSEQUENTIAL DAMAGES OF ANY KIND, NATURE OR DESCRIPTION, WHETHER FOR NONCONFORMITIES IN MATERIALS OR WORKMANSHIP UNDER ANY WARRANTY, IN CONTRACT, TORT, NEGLIGENCE, STRICT LIABILITY, OR FOR ANY OTHER REASON.

# CUSTOMER SATISFACTION

## Please Read This!

As a valued customer, your opinion and satisfaction are important to CP Techmotive. Please let us know what you think of our product(s).

Write the part number and serial number of the product(s) you have purchased before you begin our brief online survey. The numbers are located on a sticker affixed to the handle of the nutrunner or screwdriver, and exterior or interior of the controller.

### Tool Label

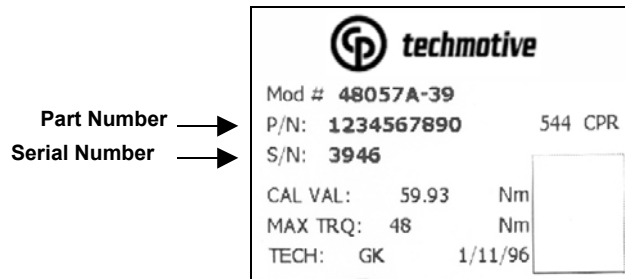

### Controller Label

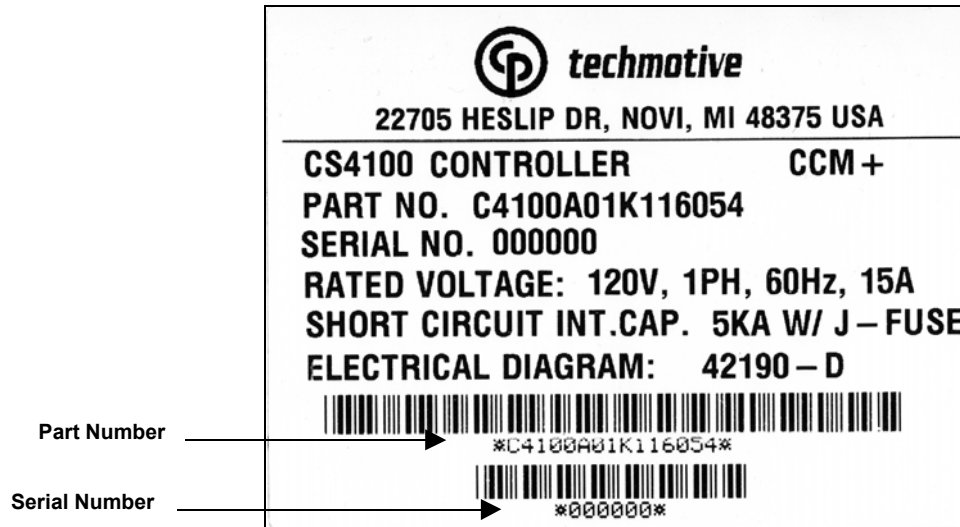

### To complete the survey:

1. Visit our website [www.cp.com](http://www.cp.com) and click [www.gsetechmotive.com](http://www.gsetechmotive.com)
2. Click the Customer Satisfaction Survey link located below the gray buttons in the red, left-hand frame.
3. Fill in the fields and click the appropriate choices.
4. Click the Submit to GSE tech-motive tool button

# Preface

Our CP techmotive SD25 Series Screwdriver is easy to operate and comes with a manual that includes instructions to help you use it safely, make minor adjustments, and perform routine maintenance.

## Who Should Use This Manual

This manual is written for the engineers and technicians, who will set up, use and maintain CP techmotive SD25 Series screwdrivers.

## How to Use This Manual

This manual introduces you to the SD25 Series Screwdriver and provides general safety and electrical safety guidelines for using it, and covers installation, adjustment, calibration and troubleshooting of the screwdrivers.

For the latest revision of drawings, please contact our Technical Service Department at 1-248-596-0600.

## Conventions

The following conventions are used throughout this manual for the safety of personnel, equipment, software, and data. The conventions include warnings, cautions, and notes, as follows:

**WARNING!** *It can be dangerous to personnel and/or machine systems, if operating instructions are not followed. The information appears in a box in italicized boldface type.*



**CAUTION!** *There may be damage to equipment, and loss of software and data, if operating instructions are not followed. The information is indented and in italicized boldface type.*



**NOTE:** *Information that adds to your knowledge of the equipment and/or software. The information is indented and italicized.*



## Abbreviations

The most common abbreviations used throughout this manual are:

<b>DCM</b>	device control module
<b>EEPROM</b>	electrically erasable programmable read only memory
<b>ESD</b>	electro-static discharge
<b>ITI</b>	intelligent tool interface
<b>LED</b>	light-emitting diode
<b>STM</b>	standard test method
<b>TCM</b>	tool control module
<b>VS</b>	Visual Supervisor is the setup, fastening, data collection and diagnostics software program designed by CP techmotive

## References

*CS2000 Mini Controller Hardware Overview Manual* (part number 39-30-38810)

*CS2000/CS4000 Mini Controller and CS4100 Controller Network and Interface Supplement* (part number 30-30-40477)

*Mobile Fastening System II (MFS II) User s Guide* (part number 39-30-37700)

*Visual Supervisor User s Guide* (part number 39-30-34823)

# Contents

<b>Preface .....</b>	<b>i</b>
<b>Who Should Use This Manual.....</b>	<b>i</b>
<b>How to Use This Manual.....</b>	<b>i</b>
<b>Conventions .....</b>	<b>i</b>
<b>Abbreviations.....</b>	<b>ii</b>
<b>References.....</b>	<b>ii</b>
<b>SD25 Series Screwdrivers.....</b>	<b>1</b>
<b>Electro-static Discharge (ESD).....</b>	<b>2</b>
<b>Think Safety First! .....</b>	<b>3</b>
<b>General Machine Safety.....</b>	<b>3</b>
<b>Electrical Safety.....</b>	<b>5</b>
<b>Getting Started.....</b>	<b>6</b>
<b>Viewing Screwdriver Functions.....</b>	<b>8</b>
<b>Installing the Screwdriver .....</b>	<b>9</b>
<b>Using Visual Supervisor Setup.....</b>	<b>10</b>
<b>Tightening a Fastener .....</b>	<b>12</b>
<b>Loosening a Fastener .....</b>	<b>12</b>
<b>Reversing the Screwdriver.....</b>	<b>13</b>
<b>Attaching a Pistol Grip Handle .....</b>	<b>13</b>
<b>Mapping Screwdriver Functions .....</b>	<b>15</b>
<b>Disabling the Push-to-Start Function .....</b>	<b>15</b>
<b>Enabling the Push-to-Start Function .....</b>	<b>16</b>
<b>Mapping Outputs for a Single-Spindle .....</b>	<b>18</b>
<b>Mapping Outputs for a Single-Spindle .....</b>	<b>18</b>
<b>Troubleshooting Your Screwdriver .....</b>	<b>20</b>
<b>Maintaining Your Screwdriver .....</b>	<b>22</b>
<b>Reading the Screwdriver Part Numbers .....</b>	<b>23</b>
<b>Specifications and Parts .....</b>	<b>25</b>
<b>Specifications.....</b>	<b>25</b>
<b>Screwdriver Accessories .....</b>	<b>26</b>



(This page is left blank intentionally.)





# SD25 Series Screwdrivers

Thank you for purchasing the CP techmotive SD25 Series Screwdriver, available in in-line and pistol grip versions.

The SD25 Series In-line Screwdriver is a compact, lightweight tool of aluminum construction, weighing one pound and measuring 9.4-in length. It provides a push-to-start output spindle and/or trigger-start for operator preference, a forward/reverse direction button, high intensity headlights, and torque good, high and low indicator lights. It also has a multi-purpose (auxiliary) button that can be used for a variety of functions.



**SD25 Series In-line Screwdriver**

The SD25 Series Pistol Grip Screwdriver is the In-line screwdriver with an attached lightweight aluminum pistol grip handle (part number 49-SD-10111).

Each SD25 Series Screwdriver has the capability to interface to a computer through a laptop computer attached to the CP techmotive CS2000 Mini Controller or CS2100 Controller.



**SD25 Series Pistol Grip Screwdriver**

**NOTE:**  
?

*Other accessories are available for the SD25 Series screwdrivers. For more information, please visit our website at <http://www.cp.com> then click on the Products button.*

## Electro-static Discharge (ESD)

The SD25 Series Screwdriver is well suited for use in electro-static discharge (ESD) safe work areas. The screwdriver has been tested and meets the requirements of ESD Standard (S) 20.20, and also section 5.1.3 of ESD Standard Test Methods (STM) 13.1.



# Think Safety First!

Working with fastening tools can be dangerous if safe and proper procedures are not followed. As with all machinery, certain hazards can be involved with the operation of the product. Using these tools with caution will considerably lessen the possibility of personal injury. If, however, safety precautions are overlooked or ignored personal injury to the operator can result.

Always use common sense and exercise caution when using these tools. They can produce torque that, unless properly compensated for, could cause personal injury. Remember, your personal safety is *your* responsibility.

Only CP techmotive-qualified service technicians should perform the procedures covered in this manual. If you are an operator or service technician, you should become familiar with the contents of this manual before operating, servicing, or performing maintenance on any part of the fastening system, including the SD25 Series screwdrivers. Familiarization with all components of the system can minimize the possibility that an accident or injury might occur.

CP techmotive assumes no responsibility for personal injury or damage to equipment resulting from misuse of these tools. After reviewing this manual you should also review all safety procedures provided by your company and the equipment installer.

**WARNING!** *Failure to follow these rules can result in serious personal injury.*

## General Machine Safety

- FOR YOUR OWN SAFETY READ THE INSTRUCTION MANUAL THOROUGHLY PRIOR TO OPERATING THE TOOL.
- DO NOT WORK IN A DANGEROUS ENVIRONMENT. Do not use power tools in a damp or wet location or explosive atmosphere, or expose them to rain, oils, or corrosive fluids.
- KNOW THE LOCATION OF POWER DISCONNECTS PRIOR TO OPERATING THIS EQUIPMENT.
- KEEP ALL ELECTRICAL PANELS CLOSED DURING OPERATION. High voltage present inside enclosure panels can result in personal injury. Do NOT bypass or defeat electrical safety devices. Turn the power actuator to the OFF position prior to any servicing or maintenance of the controller.
- OBSERVE ALL GOVERNMENT AND/OR COMPANY POWER LOCKOUT STANDARDS.
- NEVER OPERATE SOLENOID VALVES, LIMIT SWITCHES OR RELAYS MANUALLY as this practice can create dangerous, unexpected machine movements.

- **SECURE THE TOOL.** Tools that develop torque can produce hazardous torque reactions. Always be sure that the tool is properly fixtured to absorb reaction as a fastener is tightened. Never operate a tool capable of high torque without proper fixturing.
- **SECURE WORK.** Avoid situations where the part being fastened breaks loose and can cause damage.
- **NEVER TOUCH OR ATTEMPT TO STOP MOVING MACHINERY OR PARTS WITH YOUR HANDS, OTHER PARTS OF YOUR BODY, OR MAKESHIFT DEVICES.**
- **DO NOT OPERATE THE TOOL WHILE UNDER THE INFLUENCE OF ALCOHOL, DRUGS OR MEDICATION THAT CAN IMPAIR YOUR JUDGMENT.**
- **REPORT ALL UNSAFE WORKING CONDITIONS OR PRACTICES TO YOUR SUPERVISOR AND / OR SAFETY DEPARTMENT FOR CORRECTION.**
- **WEAR APPROVED SAFETY GLASSES AT ALL TIMES.**
- **DO NOT WEAR JEWELRY,** especially bracelets and rings, while operating the fastening tools. Keep hands and fingers away from all rotating parts and avoid situations where clothing can become tangled in the tool. Secure loose fitting clothing, neckties, and long hair. Wear medical alert identification cautiously.
- **DO NOT OVERREACH.** Keep proper footing and balance at all times.
- **KEEP YOUR WORK AREA CLEAN.** Do not work on or near slippery floors or surfaces. Avoid situations where the tool reacts against unexpected obstacles. Do not operate electrical equipment while standing on a wet floor.
- **MAINTAIN TOOLS IN TOP CONDITION.** Keep tools properly lubricated and clean. If any wires become frayed or exposed, replace them immediately. Prevent dirt, grease or contaminants from getting into the tool.
- **REDUCE THE RISK OF UNINTENTIONAL STARTING.** Be careful how the tool is left unattended. Avoid resting it on its throttle/trigger lever to prevent false starts.
- **CONTROL THE DIRECTION OF ROTATION.** The reaction torque changes direction when going from forward to reverse. Always be aware of the direction the tool will rotate prior to using it. If the tool is not fixtured this will allow you to brace for the proper direction of torque reaction.
- **CHECK DAMAGED PARTS.** Before further use of a tool, any part of the tool that is damaged should be carefully checked to ensure that it will operate properly and perform its intended function. Check for alignment of moving parts, breakage of parts, mounting, and any other conditions that may affect its operation. Never operate a tool that has damaged or exposed wires. Never operate a tool that has any part of the powertrain, other than the output spindle, exposed.



## Electrical Safety

Only qualified and properly trained personnel should perform electrical/electronic troubleshooting and repair. Consider the following electrical system safety guidelines:

- Before you troubleshoot or service a fastening system station, be sure you have an up-to-date and appropriate set of electrical drawings for that station.
- Remove metal items, such as rings, metal necklaces, wristwatches and jewelry, as these can create electrical hazards. Wear medical alert identification cautiously.
- Wear safety glasses, but avoid wearing those that have metal rims or metal side shields.
- It may be necessary to troubleshoot equipment while the power is ON. ONLY qualified, trained personnel should do this. During these instances, open only the panels, doors, or covers that need to be opened. Know the voltage present at all points before you begin troubleshooting.
- Use properly insulated tools when working on electrical equipment to reduce the possibility of shock. Make sure the insulation is adequate to safeguard against the high voltages present.
- If you must work on the electrical system, make sure the Ground Fault Circuit Interrupter (GFCI) is in the OFF position, or remove the plug from the AC outlet, or turn off the circuit breaker.
- Do not attempt to modify or repair the machine without the approval of the proper authorities.
- Use approved fuse pullers when changing fuses.
- Never use jumper wires or fuse substitutes to replace specified fuses.
- Always use fuses of a capacity smaller than or equal to the safe capacity of the line or the equipment it serves.
- Before you work on any circuit, check it with an appropriate testing device to be sure voltage is not present.
- Install temporary wiring as safely as possible and replace it with permanent wiring as soon as possible. Install grounding wherever it is needed in the final installation. If modifications are made to the system wiring, drawings must be revised to illustrate this change.
- Know how to deal with electrical fires properly. Keep carbon dioxide and powder extinguishers handy.

(This page is left blank intentionally)



# Getting Started

All SD25 Series handheld screwdrivers have the following features to provide torque information right at your fingertips:

- Programmable multi-purpose pushbutton for Cycle Complete, multi-parameter set selection, Data Send, etc.
- Forward / reverse direction button
- Multi-color light-emitting diode (LED) illumination ring that indicates acceptable, high and low torque/angle

The SD25 Series Screwdriver can identify its maximum speed and torque capacities to the controller. However, you may need to verify that the screwdriver you have is capable of generating the torque specified in the active parameter set displayed on the controller. If the screwdriver you are connecting to a controller is not capable of developing the torque specified in the parameter sets it will not run at all. You should first verify that the screwdriver operates properly.

All SD25 Series screwdrivers have internal memory inside that identifies how the screwdriver was configured upon manufacture. Because the SD25 Series screwdrivers are highly programmable -- through both the factory settings contained in the screwdriver memory and the configuration of your particular controller -- there are many possible combinations of screwdriver functionality.

- If your screwdriver has a multi-purpose button installed, you may have it configured to perform one of several functions.

The Visual Supervisor (VS)-based controller (CS2000 Mini Controller connected to a laptop computer) allows you to look at all of the factory or configured settings inside the screwdriver. VS also allows you to change the software selectable Inputs and Outputs, change torque settings, add parameters, enable and define the function of all switches on the screwdriver. To use the VS setup program, open it on the laptop computer connected to the CS2000 Mini Controller. Then click on the tool icon in the menu tree on the left side of the screen. Refer to *Using Visual Supervisor Setup* on page 9 for further details.

If you have any questions about the functionality of your screwdriver, contact your sales agent or the CP techmotive Technical Service Department for assistance.

## Viewing Screwdriver Functions

Before you operate your SD25 Series screwdriver, become familiar its functionality:

**NOTE:** **?** *The factory sets the functions of the screwdriver and the position of the buttons/lever in relationship to the head. Each function can be re-assigned to a different button or switch using VS.*

- Throttle/trigger lever or the push-to-start function starts and stops the screwdriver
- Forward/reverse switch runs the screwdriver in clockwise or counterclockwise direction
- LED illumination ring indicates acceptable, high and low torque/angle
- Headlights illuminate the fastening area

These are shown in the diagram below.

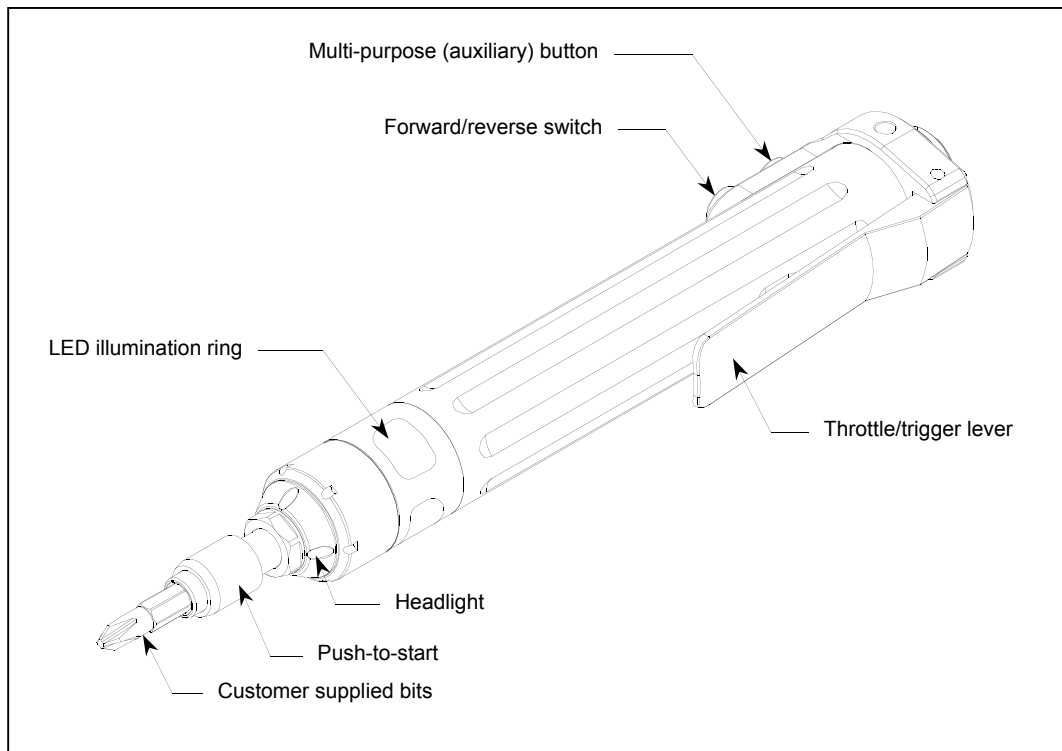

**NOTE:** **?** *Some screwdrivers, such as those designated for fixtured remote usage, do not have a throttle/trigger lever, a forward/reverse switch, or a multi-purpose button.*



## Installing the Screwdriver

Use the following procedure to install SD25 Series screwdrivers to the CS2000 Mini Controller.

### ***Installing the Screwdriver***

1. **Identify the slot on the screwdriver connector into which the screwdriver cable plugs.**
2. **Align the red dot on the grip of the screwdriver cable connector to the slot on the screwdriver connector.**

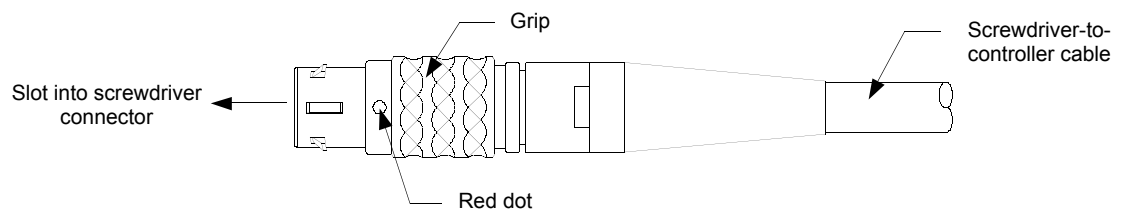

3. **Insert the screwdriver cable connector into the slot on the screwdriver connector and push firmly. There is a *click* when the cable is correctly inserted.**



**NOTE:** *To remove the cable from the screwdriver, slide the grip on the screwdriver cable connector away from the screwdriver and at the same time firmly pull the screwdriver and cable connector apart.*

4. **Connect the large end of the screwdriver cable to the controller.**
5. **Turn on power to the controller.**

You will see messages on the controller display during initialization, and the screwdriver lights will flash momentarily.

If the screwdriver lights continue to flash, read the scrolling message on the controller display. Typically, this will read "Invalid Parameter Set X." Fix the parameter set in the controller via VS.

To fix the invalid parameter set:

- Click on the Parameter Set that displays a red and black  next to it and click on the tab that also displays the . Correct the value that is highlighted in red. Refer to the *Visual Supervisor User's Guide* (part number 39-30-34823) for details.

If the parameter set does not need to be corrected, and a message other than "TRQ=" or "ANG=" continues to scroll across the controller display, it is likely to be a message indicating a data error or an operational problem. If a data error or operational problem occurs, refer to *Troubleshooting Your Screwdriver* on page 19.

## 6. Become familiar with how the screwdriver operates and feels.

Press the throttle/trigger lever and cycle the screwdriver in the air (not on a fastener). Press the forward/reverse button, then press the throttle/trigger lever and watch the output drive change direction.

### OR

Press the throttle/trigger lever to enable the cycle, position the screwdriver on a fastener and push down to start the cycle. Press the forward/reverse button, then press the throttle/trigger lever and push down to start the cycle again and watch the fastener turn in the opposite direction.

## Using Visual Supervisor Setup

The information that appears under the General Information tab for the selected screwdriver is displayed when a screwdriver is attached to the controller. The electrically erasable programmable read only memory (EEPROM) chip inside the screwdriver transmits data to the analog intelligent tool interface (ITI) board inside the controller.

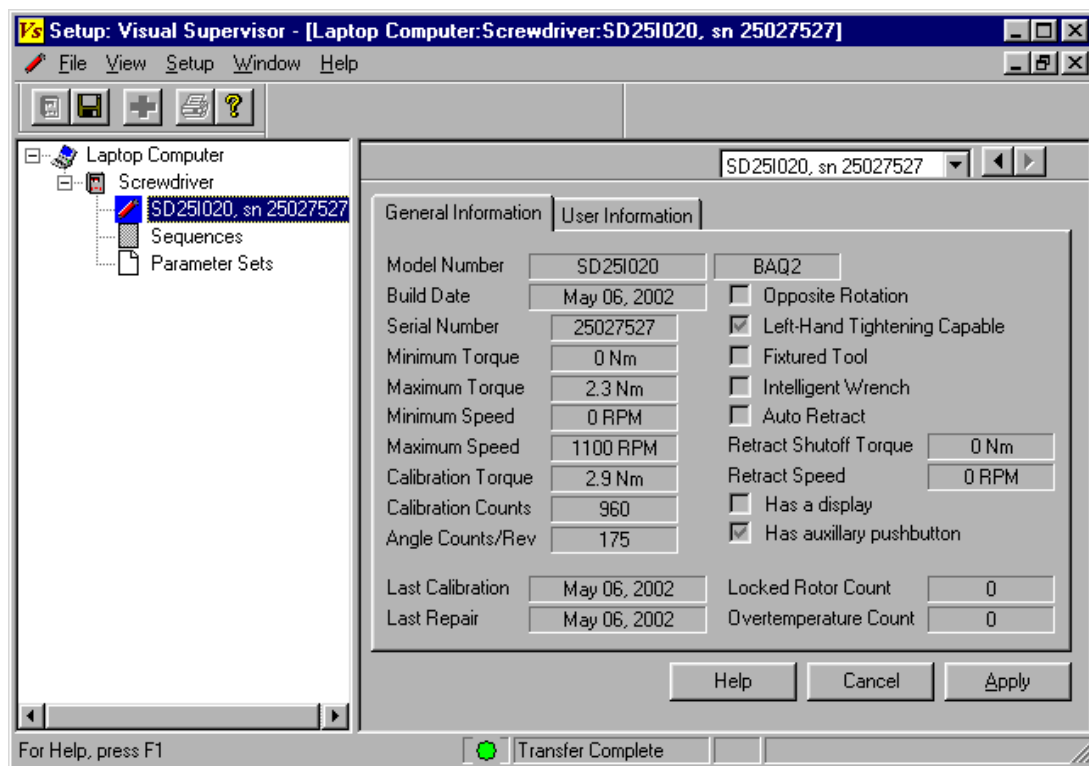

If there is no screwdriver attached, the General Information tab, the User Information tab, and all parameter set and sequence tabs are unavailable.

The values on the General Information tab vary with the attached screwdriver.

In the following table, all of the left column fields are defined in the order they appear on your screen, followed by all the second column fields.

1st Column Field	Definition
<b>Model Number</b>	CP techmotive part number for the screwdriver.
<b>Build Date</b>	The date the screwdriver was manufactured.
<b>Serial Number</b>	Alphanumeric serial number of the screwdriver.
<b>Minimum Torque</b>	Minimum usable torque value (in Nm) for the screwdriver. The controller reads this information from the screwdriver and prevents you from using it on any application where the target torque is BELOW this value.
<b>Maximum Torque</b>	Maximum usable torque value (in Nm) for the screwdriver. The controller reads this information from the screwdriver and prevents you from using it on any application where the target torque is ABOVE the maximum usable torque value of the screwdriver.
<b>Minimum Speed</b>	Minimum usable speed in revolutions per minute (RPM) of the screwdriver.
<b>Maximum Speed</b>	Maximum free speed value (in RPM) of the screwdriver.
<b>Calibration Torque</b>	The torque calibration value (in Nm) of the screwdriver.
<b>Calibration Counts</b>	The analog-to-digital reading (in A to D counts) that the controller reads from the screwdriver when the shunt calibration circuit in the screwdriver is activated.
<b>Angle Counts/Rev</b>	The angle scaling factor (in counts per revolution) for the screwdriver.
<b>Last Calibration</b>	The date the screwdriver was last calibrated.
<b>Last Repair</b>	The date the screwdriver was manufactured or last repaired.
2nd Column Field	Definition
<b>Opposite Rotation</b>	When checked, indicates the screwdriver is an opposite rotation screwdriver: for a right-handed fastener torque cycle, the motor is run in the reverse direction, and the torque and angle signals are negative going. When unchecked, indicates the screwdriver is a standard rotation screwdriver: for a right-handed fastener torque cycle, the screwdriver motor is run in the forward direction, and the torque and angle signals are positive-going.
<b>Left-Hand Tightening Capable</b>	(Also known as Bi-Directional Tightening Capable.) When checked, indicates the screwdriver has been modified for use in left-hand fastening applications (for example, reverse torque cycles, such as tightening a left-hand threaded fastener).
<b>Fixtured Tool</b>	When checked, indicates the screwdriver is designed for fixtured applications and has no on-board controls for cycle start or direction.
<b>Intelligent Wrench</b>	When checked, indicates the tool is not a screwdriver, but an intelligent hand torque wrench.
<b>Auto Retract</b>	When checked, indicates that the tool is a tubenut tool and the output socket must be retracted to the open position when the tool trigger is released. This option does not apply to screwdrivers.
<b>Retract Shutoff Torque</b>	When Auto Retract is checked, defines the shutoff torque setting (in engineering units) for tubenut tools. This option does not apply to screwdrivers.
<b>Retract Speed</b>	When Auto Retract is checked, defines the speed setting (in RPM) for tubenut tools. This option does not apply to screwdrivers.
<b>Has a display</b>	When checked, indicates the attached tool has a digital display. This option does not apply to screwdrivers.



2nd Column Field	Definition (continued from previous page)
<b>Has auxiliary pushbutton</b>	When checked, indicates that a screwdriver with multi-purpose (auxiliary) pushbutton is attached.
<b>Locked Rotor Count</b>	The total number of locked rotor faults the screwdriver has had.
<b>Overtemperature Count</b>	The total number of motor overheating faults the screwdriver has had. Such faults occur when the winding temperature is higher than 125 degrees Celsius.

## Tightening a Fastener

For most fastening operations, make sure the screwdriver turns *clockwise* when running forward. For left-hand fastening capable screwdrivers, make sure the screwdriver turns *counterclockwise* when running forward.

Once the screwdriver is positioned on a part, you begin the rundown (cycle start) by:

- Pressing the trigger lever on handheld screwdrivers that have the push-to-start function disabled  
OR
- Pressing the trigger lever on handheld screwdrivers that have the push-to-start function enabled, then pushing down firmly on the screwdriver  
OR
- Asserting (activating) the remote start input on fixtured screwdrivers

The cycle start signal must remain active in order to complete the rundown. If the signal is interrupted - if you release the trigger lever, for example - the screwdriver stops immediately.

When the rundown is complete, you can see the status of the rundown by:

- The illumination of the LEDs on the screwdriver - green for acceptable torque/angle, yellow for low torque/angle, and red for high torque/angle
- The controller display
- VS software displays the final torque/angle

**NOTE:** *For details of asserting (activating) remote inputs and reading the controller display, refer to the appropriate controller manual.*

?

## Loosening a Fastener

For unfastening operations, make sure screwdriver turns *counterclockwise* when running forward. For left-hand fastening capable screwdrivers, make sure the screwdriver turns *clockwise* when running forward.

Once the screwdriver is positioned on a part, you begin the rundown (cycle start) by:

- Pressing the trigger lever on handheld screwdrivers
- Asserting (activating) the remote reverse direction input on fixtured screwdrivers

The cycle start signal must remain active in order to complete the rundown. If the signal is interrupted - if you release the trigger lever, for example - the screwdriver stops immediately.

## Reversing the Screwdriver

When the screwdriver is put into reverse, by sliding the forward/reverse switch into the reverse setting or remotely activating the FWD/REV input, the screwdriver turns in the opposite direction to the normal fastening direction. Reverse is indicated by the yellow, green and red LEDs chasing in a counterclockwise direction while the headlights remain lit. For most fastening operations, the screwdriver turns in a *counterclockwise* direction when in reverse, but for left-hand fastening applications it is *clockwise*.

## Attaching a Pistol Grip Handle

The diagram below shows the SD25 Series In-line screwdriver with the throttle/trigger lever and spring removed and the Pistol Grip handle (part number 49-SD-10111) slid into place.

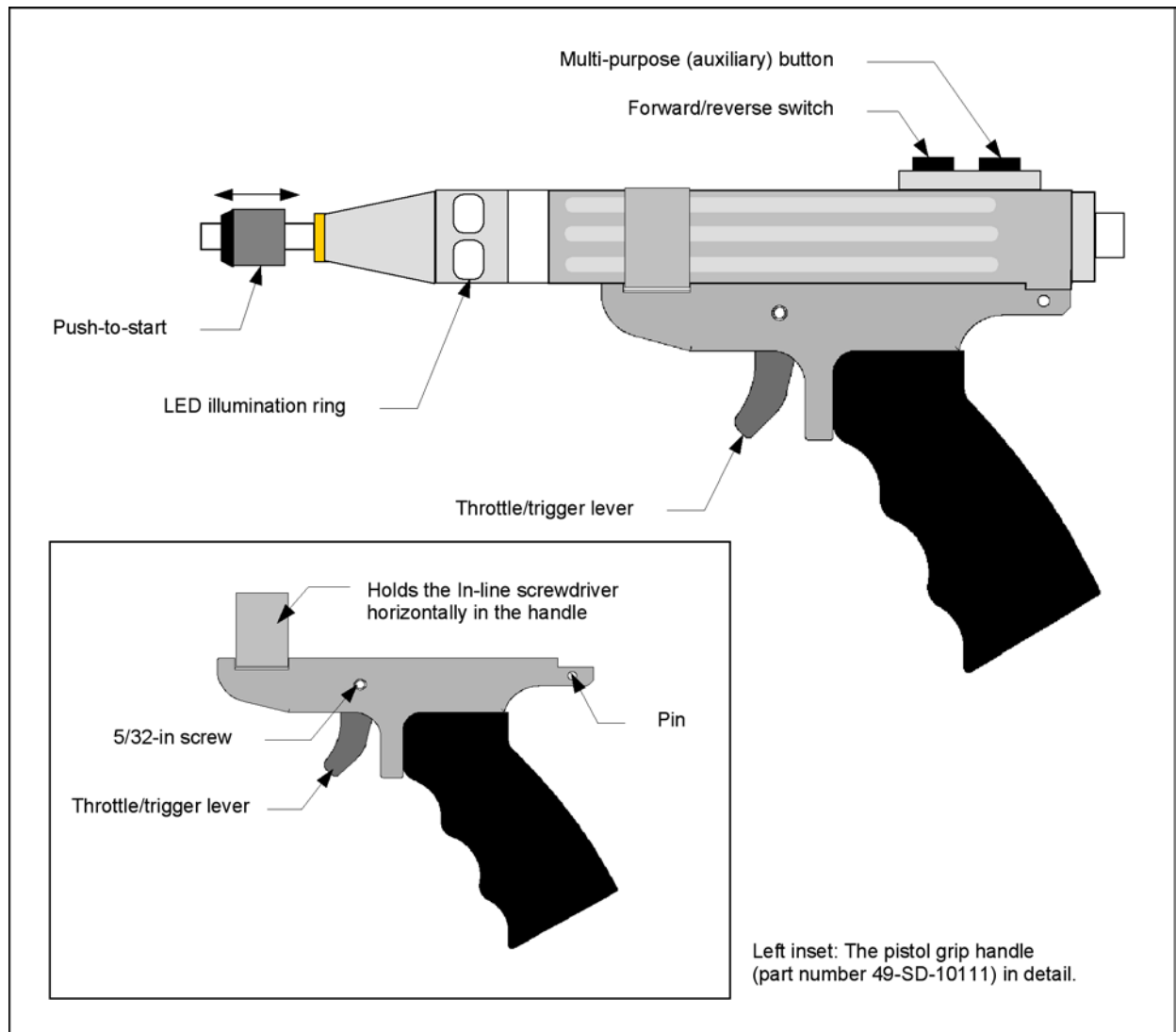

Use the following procedure to attach a Pistol Grip handle (part number 49-SD-10111) to an In-line screwdriver. Refer to *Viewing Screwdriver Functions* on page 7 to view an illustration of the In-line screwdriver that may help you with this procedure.

### ***Attaching a Pistol Grip Handle***

---

- 1. Remove the screwdriver-to-controller cable, if necessary.**
- 2. Using a 5/32-in punch, hammer out the pin that attaches the throttle/trigger lever to the In-line screwdriver.**
- 3. Remove the throttle/trigger lever spring. It may fall out when you remove the throttle/trigger lever so be prepared to catch it.**

**NOTE:** *Put the throttle/trigger lever and spring into a safe place. If, in the future, you remove the handle attachment, you will need the throttle/trigger lever and spring to convert the screwdriver back to the In-line model.*
- 4. Carefully slide the In-line screwdriver into the handle attachment with the forward/reverse and multi-purpose (auxiliary) buttons positioned on the top.**
- 5. Position the handle on the bottom of the screwdriver, on the side of the screwdriver opposite to the forward/reverse and multi-purpose (auxiliary) buttons.**
- 6. Slide the pin back into the handle attachment.**

You will need to hammer it carefully back into place. Make sure the screwdriver does not rotate or move in relation to the position of the handle during this process.
- 7. Using a 5/32-in Allen wrench, tighten the fastener on the handle attachment until it is secure.**

You are now ready to use your Pistol Grip screwdriver.



# Mapping Screwdriver Functions

This section describes how VS is used to map screwdriver functions to the buttons and switches on the screwdriver. You can also use VS to change the default mapping. To do this, refer to the *Visual Supervisor User's Guide* (part number 39-30-34823).

## Disabling the Push-to-Start Function

Typically, to start a fastening cycle when the push-to-start function on a handheld screwdriver is disabled:

- Press the throttle/trigger lever to start the fastening cycle.
- Release the throttle/trigger lever to stop the fastening cycle.

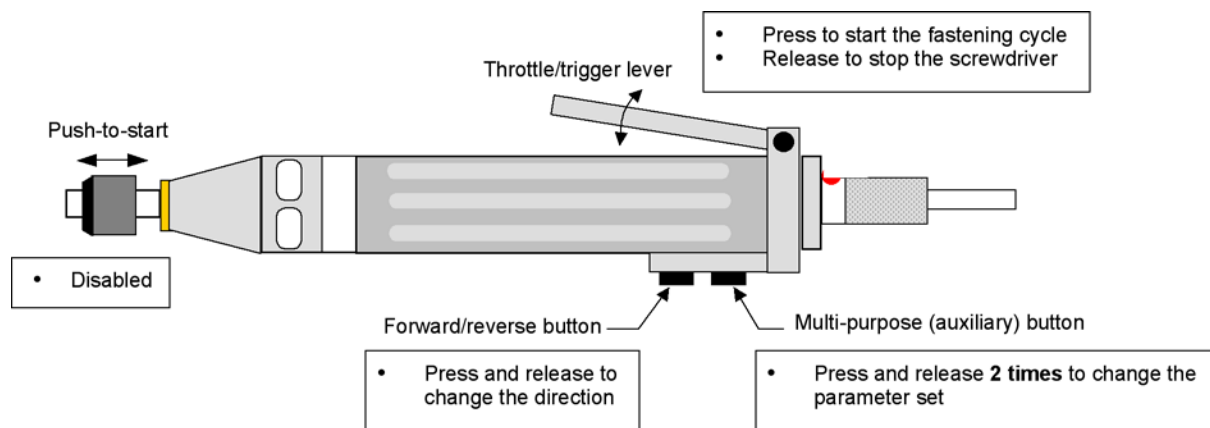

The screwdriver inputs are software selectable using VS. To disable the push-to-start function, assign the Cycle On input, Cycle Enable input and the Clear Outputs input to the Trigger. The typical inputs for a screwdriver with push-to-start function disabled are shown below.

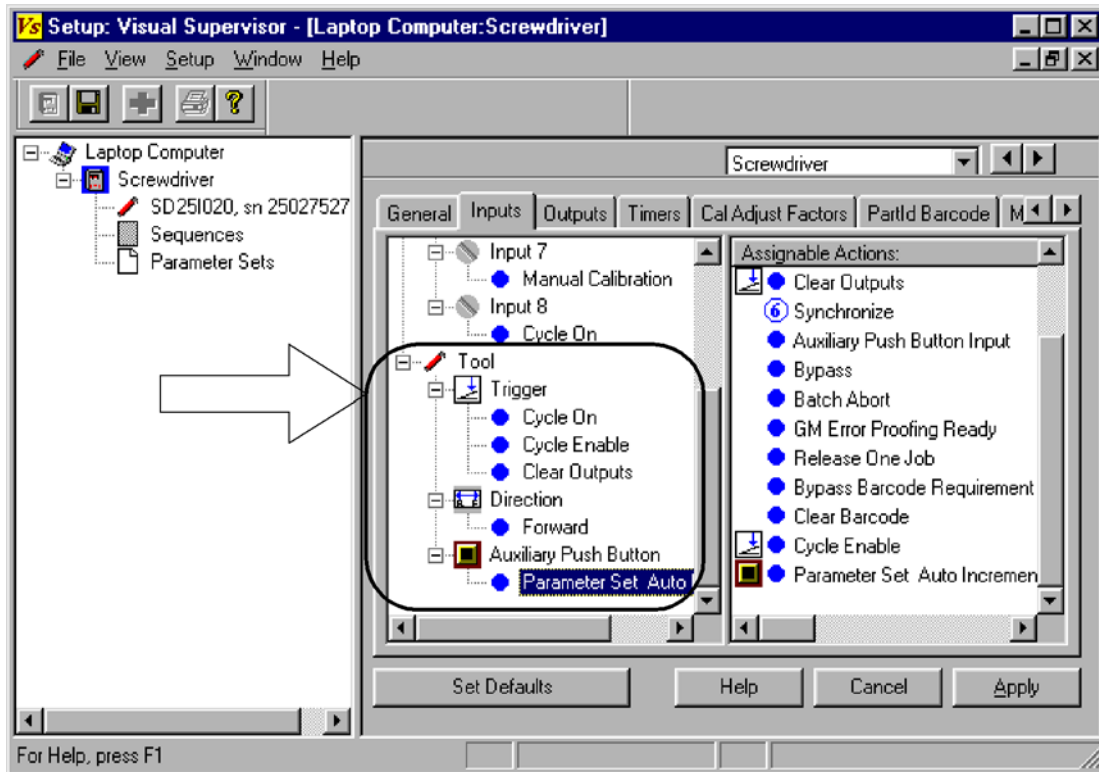

## Enabling the Push-to-Start Function

Typically, to start a fastening cycle when the push-to-start function on a handheld screwdriver is enabled:

- Press the throttle/trigger lever to enable the fastening cycle.
  - Push down firmly on the screwdriver to start the fastening cycle.
  - Release the throttle/trigger lever to stop the fastening cycle.
- OR
- Release the pressure on the screwdriver to stop the fastening cycle.



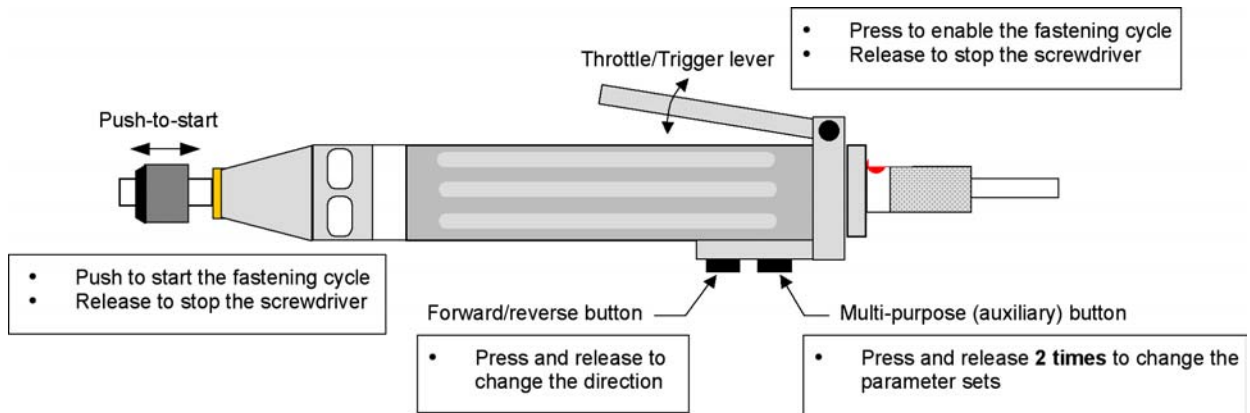

The screwdriver inputs are software selectable using VS. To enable the push-to-start function, assign the Cycle On input to Input 8, and assign the Cycle Enable input and Clear Outputs input to the Trigger. The typical inputs for a screwdriver with push-to-start function enabled are shown below.

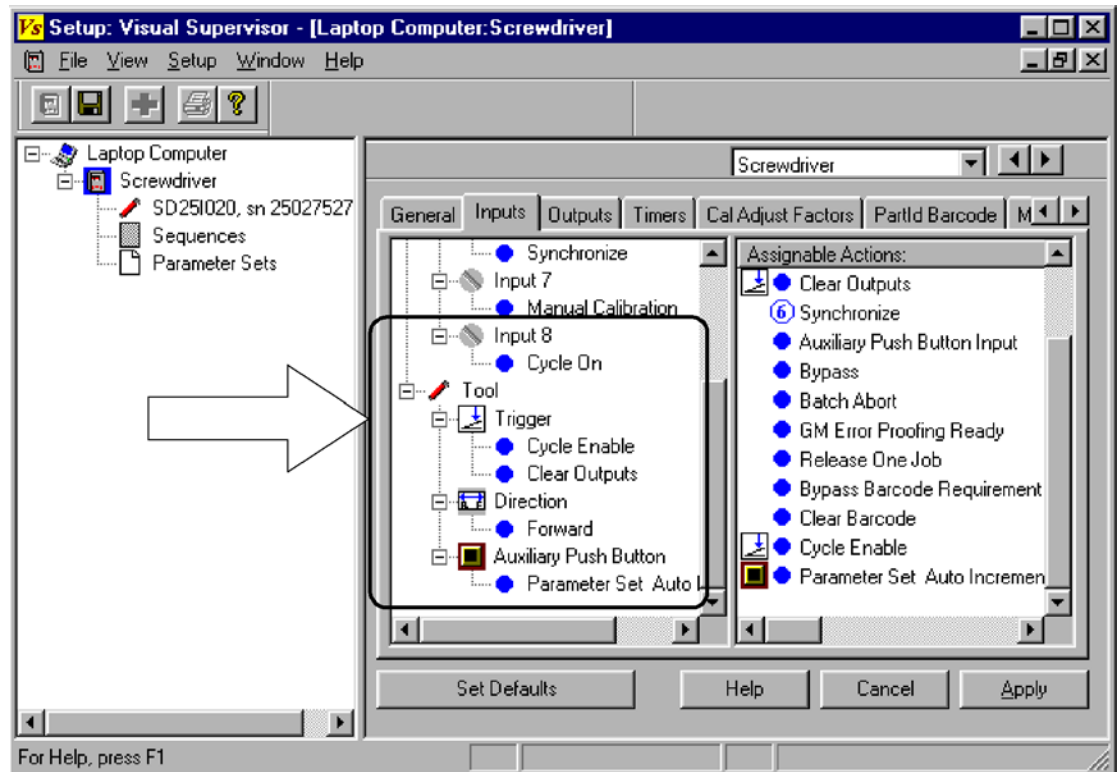

## Mapping Outputs for a Single-Spindle

Typically, the LEDs and headlights on the screwdriver work in the following way:

- Headlights turn on while the screwdriver is running in forward or reverse.

**NOTE:**  *Yellow, green and red LEDs chase each other in a counterclockwise direction while the screwdriver is in reverse.*

- Green LEDs turn on to indicate a successful cycle completion achieving target torque/angle within acceptable range.
- Yellow LEDs turn on to indicate lower than acceptable torque/angle.
- Red LEDs turn on to indicate higher than acceptable torque/angle.

The screwdriver outputs are software selectable using VS. To operate the screwdriver as a single-spindle tool, assign the Cycle Good output to Output 2, Cycle Bad output to Output 3, Output 8 (Timed Copy) to Output 7 and the Ready output to Output 8. The typical outputs for operating the screwdriver as a single-spindle tool are shown below.

**NOTE:**  *The time delay for Output 8 (Timed Copy) can be adjusted using the Timers tab in VS. For details, refer to the Visual Supervisor User's Guide (part number 39-30-34823).*

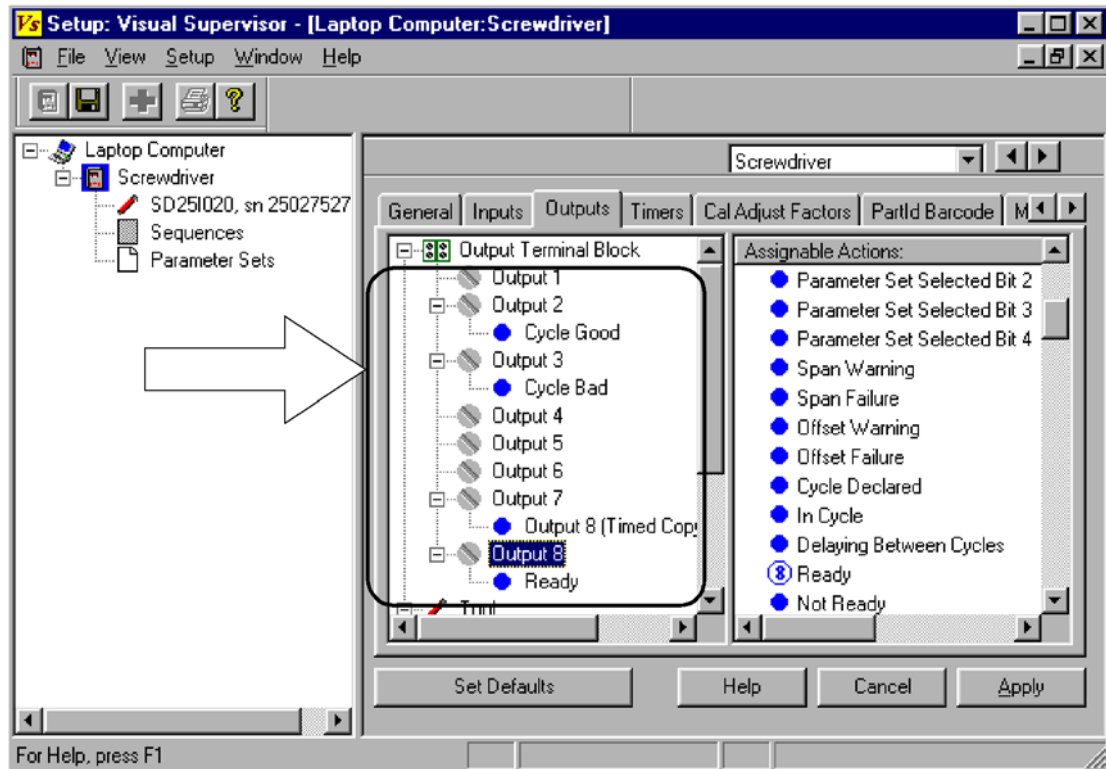

The typical outputs for screwdriver LEDs are shown below.

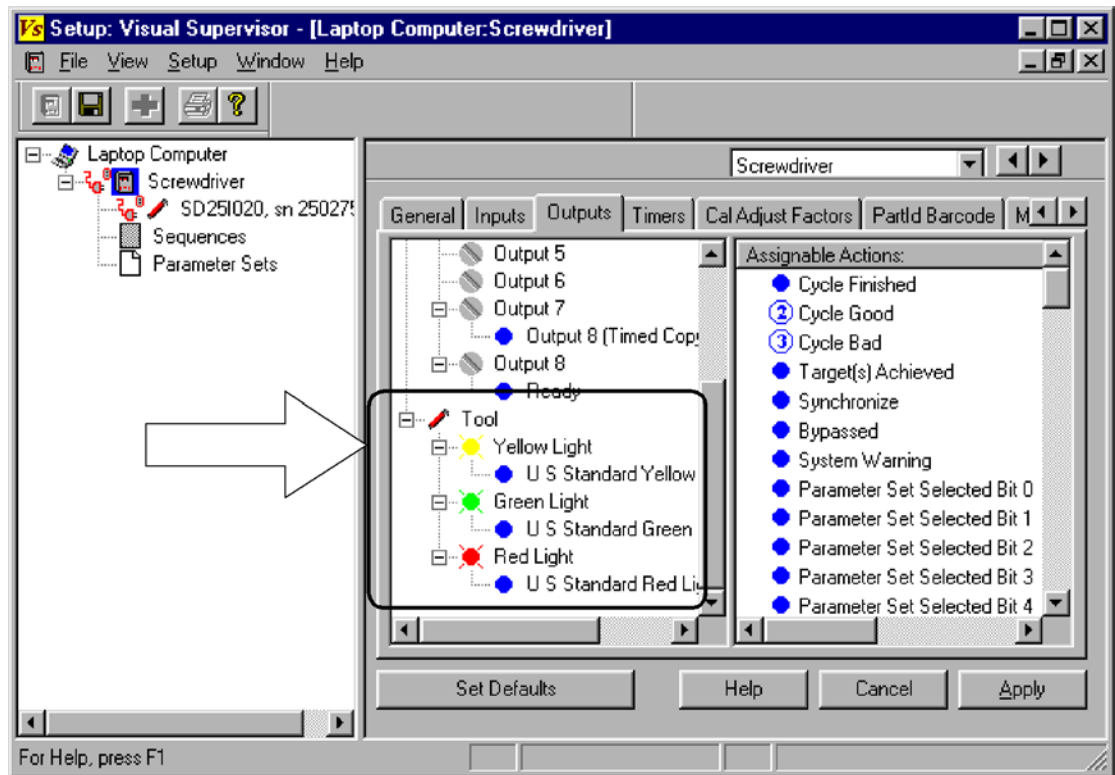

(This page is left blank intentionally)



# Troubleshooting Your Screwdriver

The CS2000 Mini Controller used with the screwdriver has many configurable features and programmable parameters that control the operation of the fastening system equipment. CP techmotive supply the VS software program that provides you with a way to change parameters that affect operation of the controller and attached screwdriver. If you apply these features or program the parameters improperly, erroneous data and manufacturing problems can result. Proper setup of the controller is essential in preventing such situations.

Whenever the data seems to be in error or operational problems occur, refer to one of the following manuals:

- ⇒ *CS2000 Mini Controller Hardware Overview Manual* (part number 39-30-38810)
- ⇒ *CS2100 Controller Hardware Overview Manual* (part number 39-30-41886)
- ⇒ *CS2000/CS4000 Mini Controller Network and Interface Supplement* (part number 39-30-40477)
- ⇒ *CS4100/2100 Controllers Technical Reference* (part number 39-30-41994)
- ⇒ The online help manual that is part of the VS software



# Maintaining Your Screwdriver

Generally, there is no preventive maintenance required for CP techmotive screwdrivers. CP techmotive only recommends trained technicians to perform in-depth maintenance, such as motor, transducer, or gearing replacement.

**NOTE:**  For the latest assembly drawing revisions, contact our Technical Service Department at 1-248-596-0600.



# Reading the Screwdriver Part Numbers

All SD25 Series Screwdrivers have an 8-digit prefix that helps you quickly identify the type of screwdriver you are using, and a longer suffix that provides more details about the screwdriver.

## Prefix example: SD25I010

SD	25	I	010
Screwdriver	Series	Type: In-line	Capacity lbf-in

## And the suffix:

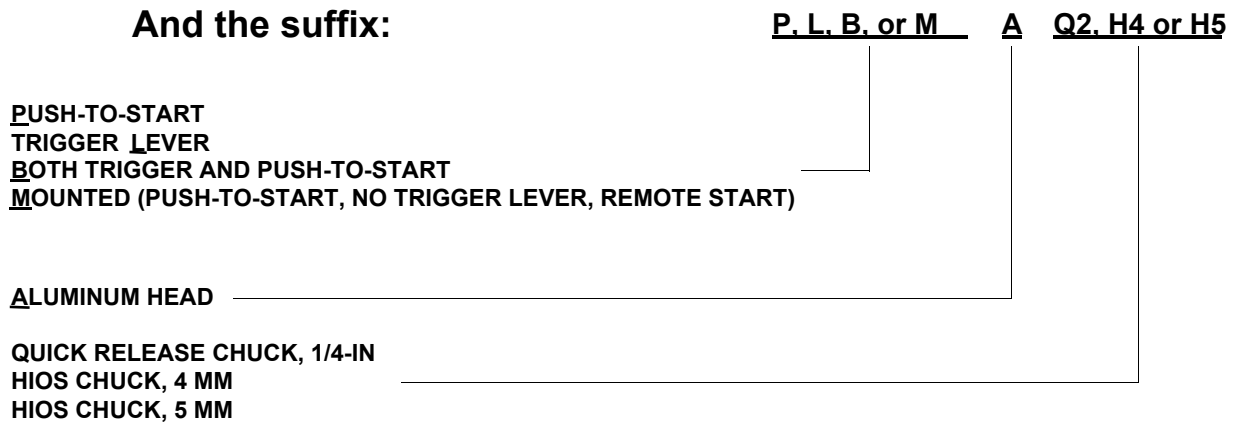





# Specifications and Parts

This section lists the specifications of your SD25 Series screwdrivers under typical operating conditions and available screwdriver-to-controller cables.

## Specifications

This section lists general specifications, torque and RPM ranges, and length and weight ranges for SD25 Series screwdrivers.

**General Specifications for SD25 Series Screwdrivers**

Description	Specifications
Motor current	8A peak
Motor commutation	Hall-based, brushless DC motor
Screwdriver logic power	24 VDC
Screwdriver pushbuttons*	Start, direction, auxiliary, push-to-start
Screwdriver connector	High density 26-pin connector
Screwdriver Display	Three indicator / status LEDs for torque/angle
Screwdriver Headlights	Turn on when screwdriver is running in forward or reverse
Ambient operating temperature	0X to 60X C (32X to 140X F)
Relative humidity	0 to 85% R.H. (non-condensing)

\* Not available on fixtured screwdrivers

**Torque, RPM, Length and Weight Ranges of SD25 Series Screwdrivers**

Screwdriver Type	Torque Range				RPM Range	Length Range	Weight Range
	Nm	lbf-in	ozf-in	kgfcm			
In-line	1.1	10	160	11.5	1700	9.4 in / 239 mm	0.91 lb / 0.41 kg
In-line	3.3	20	320	23.0	1100	9.4 in / 239 mm	0.91 lb / 0.41 kg
In-line	3.9	35	560	40.3	800	9.4 in / 239 mm	0.91 lb / 0.41 kg
In-line	5.6	50	800	57.6	500	9.6 in / 244 mm	1.1 lb / 0.49 kg

## Screwdriver Accessories

This section lists part numbers for the screwdriver-to-controller cables, suspension bail, reaction mounting plates, and foam grip available for the SD25 Series screwdrivers.

### Screwdriver-to-Controller Cables

Part Number Straight	Part Number Right Angle	Length
299230-81050	299230-81050R	5 ft / 1.5 m
299230-81100	299230-81100R	10 ft / 3.0 m
299230-81150	299230-81150R	15 ft / 4.6 m
299230-81200	299230-81200R	20 ft / 6.1 m
299230-81250	299230-81250R	25 ft / 7.6 m
299230-81300	299230-81300R	30 ft / 9.1 m
299230-81350	299230-81350R	35 ft / 10.7 m
299230-81400	299230-81400R	40 ft / 12.2 m
299230-81450	299230-81450R	45 ft / 13.7 m
299230-81500	299230-81500R	50 ft / 15.2 m

### Screwdriver Suspension Bail

Part Number	Description
49-SD-10112	Vertical Suspension Bail

### Screwdriver Mounting Plates

Part Number	Description
49-SD-10121	Reaction mounting plate, double flange, for fixtured mounting
49-SD-10125	Reaction mounting plate, single flange, for close fixtured mounting

### Screwdriver Foam Grip

Part Number	Description
31-80-39445	Foam grip for the SD25 Series In-line Screwdriver

### Screwdriver Pistol Grip Attachment for In-line SD25 Screwdriver)

Part Number	Description
31-SD-10111	Pistol grip for the SD25 Series In-line Screwdriver



(This page is left blank intentionally)



[www.cp.com](http://www.cp.com)

---



Please find your local contact at: [www.cp.com](http://www.cp.com)

 Chicago  
Pneumatic

 *Desoutter*

 GEORGES  
RENAULT

 前哨  
QIANSHAO

 SCANROTOR

 *techmotive*

U.S. English  
Printed in USA  
Copyright 2005  
CP Techmotive, Novi, MI, USA

## Free Manuals Download Website

<http://myh66.com>

<http://usermanuals.us>

<http://www.somanuals.com>

<http://www.4manuals.cc>

<http://www.manual-lib.com>

<http://www.404manual.com>

<http://www.luxmanual.com>

<http://aubethermostatmanual.com>

Golf course search by state

<http://golfingnear.com>

Email search by domain

<http://emailbydomain.com>

Auto manuals search

<http://auto.somanuals.com>

TV manuals search

<http://tv.somanuals.com>