

CHICAGO ELECTRIC® **welding systems**

90 AMP FLUX WIRE WELDER

Model 94056

SET UP AND OPERATING INSTRUCTIONS



Distributed exclusively by Harbor Freight Tools®.
3491 Mission Oaks Blvd., Camarillo, CA 93011
Visit our website at: <http://www.harborfreight.com>



Read this material before using this product.
Failure to do so can result in serious injury.
SAVE THIS MANUAL.

Copyright© 2005 by Harbor Freight Tools®. All rights reserved. No portion of this manual or any artwork contained herein may be reproduced in any shape or form without the express written consent of Harbor Freight Tools. Diagrams within this manual may not be drawn proportionally. Due to continuing improvements, actual product may differ slightly from the product described herein. Tools required for assembly and service may not be included.

For technical questions or replacement parts, please call 1-800-444-3353.

REV 06g, 09e, 09h

SPECIFICATIONS

Welding Current	.8 mm wire on 16 ga. sheet steel	104.3/95.5 A (Max/Min Setting)
	.8 mm wire on 1/4" steel plate	103.7/103.1 A (Max/Min Setting)
Duty Cycle	10% @ 90 Amps (Max Setting) or 10% @ 80 Amps (Min Setting, actual 11%)	
Power Consumption	120 V~, 24 A	
Ground Cable	4 AWG, single insulation, 6'	
Torch Power Cable	8 AWG, single insulation, 6'	
Thermal Overload	Both settings: 10 min. shutdown, 3 min. back on with Light	
Welder Tip	0.030"; Spare: Welder Tip 0.035"; Will also accept a 0.023" welder tip (not included)	
Wire Size	0.030" flux core wire (using 0.030" Welder Tip)	
Wire Spool Size	4" diameter	
Overall Dimensions	14-1/2" (L) x 7-7/8" (W) x 15-1/2" (H)	
Weight	34.45 lb.	
Accessories	Spare Welder Tip (0.035")	

Note: Performance of this tool may vary depending on variations in local line voltage. Extension cord usage may also affect tool performance.

SAVE THIS MANUAL

You will need the manual for the safety warnings and precautions, assembly instructions, operating and maintenance procedures, parts list and diagram. Keep your invoice with this manual. Write the invoice number on the inside of the front cover. Keep the manual and invoice in a safe and dry place for future reference.

SAFETY WARNINGS AND PRECAUTIONS

WARNING: When using tool, basic safety precautions should always be followed to reduce the risk of personal injury and damage to equipment.

Read all instructions before using this tool!

1. **Keep work area clean.** Cluttered areas invite injuries.
2. **Observe work area conditions.** Do not use machines or power tools in damp or wet locations. Don't expose to rain. Keep work area well lighted. Do not use electrically powered tools in the presence of flammable gases or liquids.
3. **Keep children away.** Children must never be allowed in the work area. Do not let them handle machines, tools, or extension cords.
4. **Store idle equipment.** When not in use, tools must be stored in a dry location to inhibit rust. Always lock up tools and keep out of reach of children.
5. **Do not force tool.** It will do the job better and more safely at the rate

REV 061

SKU 94056



For technical questions, please call 1-800-444-3353.

Page 2

- for which it was intended. Do not use inappropriate attachments in an attempt to exceed the tool capacity.
6. **Use the right tool for the job.** Do not attempt to force a small tool or attachment to do the work of a larger industrial tool. There are certain applications for which this tool was designed. Do not modify this tool and do not use this tool for a purpose for which it was not intended.
 7. **Dress properly.** Do not wear loose clothing or jewelry as they can be caught in moving parts. Protective, electrically nonconductive clothes and nonskid footwear are recommended when working. Wear restrictive hair covering to contain long hair.
 8. **Use eye and ear protection.** Always wear ANSI-approved, arc-shaded, impact safety face shield. Always use the full face shield when welding. Wear a NIOSH-approved dust mask or respirator when working around metal, chemical dusts, fumes and mists.
 9. **Do not overreach.** Keep proper footing and balance at all times. Do not reach over or across running machines.
 10. **Maintain tools with care.** Keep tools sharp and clean for better and safer performance. Follow instructions for lubricating and changing accessories. Inspect tool cords periodically and, if damaged, have them repaired by an authorized technician. The handles must be kept clean, dry, and free from oil and grease at all times.
 11. **Disconnect power.** Unplug tool when not in use.
 12. **Remove adjusting keys and wrenches.** Check that keys and adjusting wrenches are removed from the tool or machine work surface before plugging it in.
 13. **Avoid unintentional starting.** Be sure the switch is in the Off position when not in use and before plugging in. Do not carry any tool with your finger on the trigger, whether it is plugged in or not.
 14. **Stay alert.** Watch what you are doing, use common sense. Do not operate any tool when you are tired.
 15. **Check for damaged parts.** Before using any tool, any part that appears damaged should be carefully checked to determine that it will operate properly and perform its intended function. Check for alignment and binding of moving parts; any broken parts or mounting fixtures; and any other condition that may affect proper operation. Any part that is damaged should be properly repaired or replaced by a qualified technician. Do not use the tool if any switch does not turn On and Off properly.
 16. **Guard against electric shock.** Prevent body contact with grounded surfaces such as pipes, radiators, ranges, and refrigerator enclosures.
 17. **Replacement parts and accessories.** When servicing, use only identical replacement parts. Use of any other parts will void the warranty. Only use accessories intended for use with this tool.

Approved accessories are available from Harbor Freight Tools.

18. **Do not operate tool if under the influence of alcohol or drugs.** Read warning labels on prescriptions to determine if your judgment or reflexes are impaired while taking drugs. If there is any doubt, do not operate the tool.
19. **Maintenance.** For your safety, service and maintenance should be performed regularly by a qualified technician.
20. **Use proper size and type extension cord.** If an extension cord is required, it must be of the proper size and type to supply the correct current to the tool without heating up. Otherwise, the extension cord could melt and catch fire, or cause electrical damage to the tool. This tool requires use of an extension cord of **20 amps** minimum capability (up to 30 feet), with wire size rated at **12 AWG**. Longer extension cords require larger size wire. If you are using the tool outdoors, use an extension cord rated for outdoor use (signified by "WA" on the jacket).
21. **Avoid electrical shock.** Do not permit electrically live parts, cables, or electrodes to contact skin, clothing, or gloves. Protective clothing should be hole-free, dry, and ANSI-approved. This unit draws enough current to cause serious injury or death. Before turning the welder on, check the electrode holder to be sure that there are no protruding screw heads, and that all insulation is secure. Do not weld unless you are insulated from ground and the work piece.

⚠ WARNING	
	
INHALATION HAZARD: Welding and Plasma Cutting Produce TOXIC FUMES.	
<p>Exposure to welding or cutting exhaust fumes can increase the risk of developing certain cancers, such as cancer of the larynx and lung cancer. Also, some diseases that may be linked to exposure to welding or plasma cutting exhaust fumes are:</p> <ul style="list-style-type: none">• Early onset of Parkinson's Disease• Heart disease• Ulcers• Damage to the reproductive organs• Inflammation of the small intestine or stomach• Kidney damage• Respiratory diseases such as emphysema, bronchitis, or pneumonia <p>Use natural or forced air ventilation and wear a respirator approved by NIOSH to protect against the fumes produced to reduce the risk of developing the above illnesses.</p>	

22. **Avoid breathing fumes or gases.** They can cause serious health problems. Use an active ventilation system directly above the welding area. Keep your head out of the fumes.
23. **Avoid eye and body damage.** Welding rays and infrared radiation can injure eyes and burn skin. Wear ANSI-approved eye and body protection. Do not allow viewing by visitors without proper eye and body protection. Use a face shield with arc-shaded filter plate.

24. **Know proper welding practices.** Read and understand the manufacturer's instructions, as well as your employer's safety practices for welding.
25. **Connect only to a code approved power source.** Connect only to a grounding power source conforming to the National Electrical Code and Local Codes.
26. **Avoid fire and explosion.** Remove flammable and explosive material from at least 35 feet from the welding site to prevent welding sparks or molten metal from starting a fire. Keep a type ABC fire extinguisher within easy reach. Thoroughly clean the object being welded of any paint, grease, or other foreign material.
27. **Avoid being burned.** Always wear ANSI-approved welding gear: leather gloves, leather apron, and shoes.
28. **WARNING:** This product, when used for welding, plasma cutting, soldering, or similar applications, produces chemicals known to the State of California to cause cancer and birth defects (or other reproductive harm). (California Health & Safety Code § 25249.5, *et seq.*)
29. **The warnings, cautions, and instructions discussed in this instruction manual cannot cover all possible conditions and situations that may occur. It must be understood by the operator that common sense and caution are factors which cannot be built into this product, but must be supplied by the operator.**

UNPACKING

When unpacking, check to make sure the item is intact and undamaged. If any parts are missing or broken, please call Harbor Freight Tools at 1-800-444-3353 as soon as possible.

ASSEMBLY

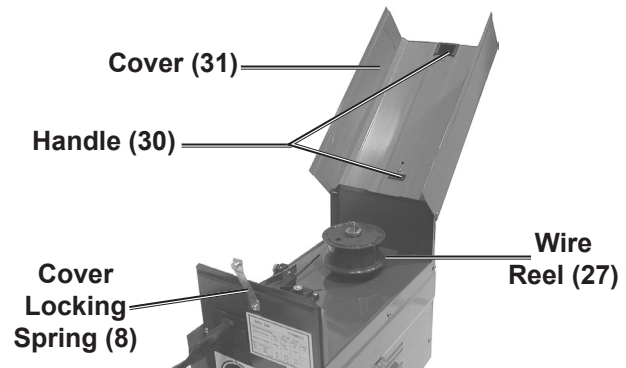

1. Attach the Handle (30) to the Cover (31) using screw (29) inserted from the Handle top-rear.
2. Attach the Cover Locking Spring (8) to the front of the Base Frame (14) using the supplied self-tapping screw.

CONTROLS

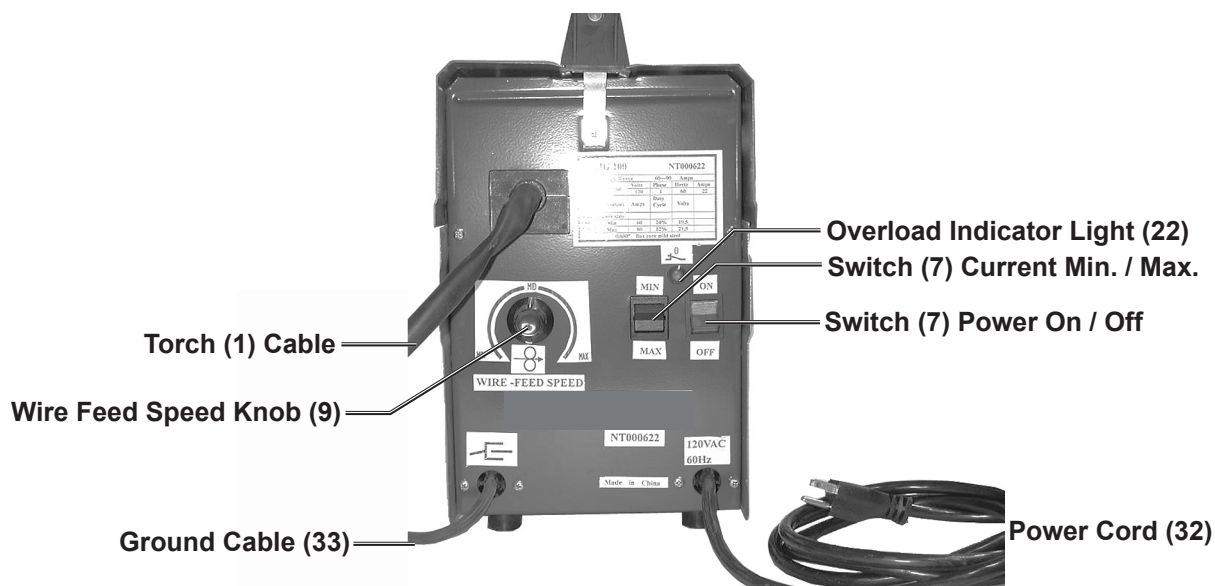

DUTY CYCLE

Duty cycle is a welding equipment specification, which defines the number of minutes, within a 10-minute period, during which a given welder can safely produce a particular welding current. For example, this 90 amp welder with a 10% duty cycle must be rested for at least 9 minutes after 1 minute of continuous welding.

Failure to carefully observe duty cycle limitations can easily overstress a welder's power generation system contributing to premature welder failure. Many welders do not have internal protection systems that prevent this sort of over stress -- leaving the task to the owner or operator.

OPERATION

This Welder is used to weld sheet metal and light carbon steel.

Caution: Before welding, read and understand all safety precautions and warnings listed on pages 2 through 5.

1. Securely clamp the Ground Cable Clamp (33) as close as possible to the metal object to be welded, or to the metal work bench where the object is mounted and electrically connected.
2. Set the switch on the control panel to MIN or MAX, as appropriate.
3. Verify that the Power Switch is in the OFF position, then plug the Welder plug into a dedicated, 110 VAC, 20 amp line with delayed action type circuit breaker or fuses.

If an extension cord is used, it must have the following wire size: up to 30 feet, use 12 AWG size wire; 30 to 50 feet, use 10 AWG wire; Over 50 feet, use 8 AWG wire.

4. While holding the Torch Cable Clamp with electrode wire clearly out of the way of any grounded objects, turn the Power Switch to the ON position.
5. Momentarily press the Torch switch to test the wire feed speed. Adjust the speed by turning the Wire Feed Speed Knob (9).
6. Orient yourself on the area to be welded, then place a face shield over your eyes.

Warning: Never look at the ignited arc without ANSI-approved, arc-shaded, eye protection in a full face shield. Permanent eye damage or blindness can occur. Skin burns can occur. Never breathe welding fumes.

7. Press (and hold) the Torch button and stroke the area to be welded with the electrode wire to ignite the arc. Never tap the electrode wire into the welding surface to ignite the arc. This damages its external coating on the electrode which prevents oxygen in the air from coming into contact with the molten metal, causing it to oxidize.

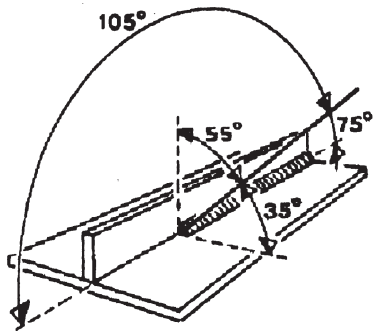

8. Once the arc is ignited, tilt the electrode wire forward at an angle of approximately 35°. The wire feeds automatically at a

speed dependent on the Min. or Max. current setting.

Note: If too much current is drawn from the Welder, the Thermal Overload protector will activate, the amber indicator will light, and the Welder will turn off until it cools down. If this happens, turn the Power Switch to the OFF position and wait about 3 ~ 5 minutes.

9. When the weld is complete, lift the electrode wire clearly away from any grounded object, set the face shield down, turn toward the Welder, and turn the Power Switch to the OFF position.
10. Unplug the Power Cord from the electrical outlet.

MAINTENANCE

Caution: Before performing any maintenance on the Welder, unplug the Power Cord from the electrical outlet.

1. Periodically remove the Right and Left side panels (12 and 13), and using compressed air, blow out all dust from the interior.
2. Store in a clean and dry location.

Replacing the Wire Reel

When the wire on the Feed Reel is used up, you will need to replace it as follows.

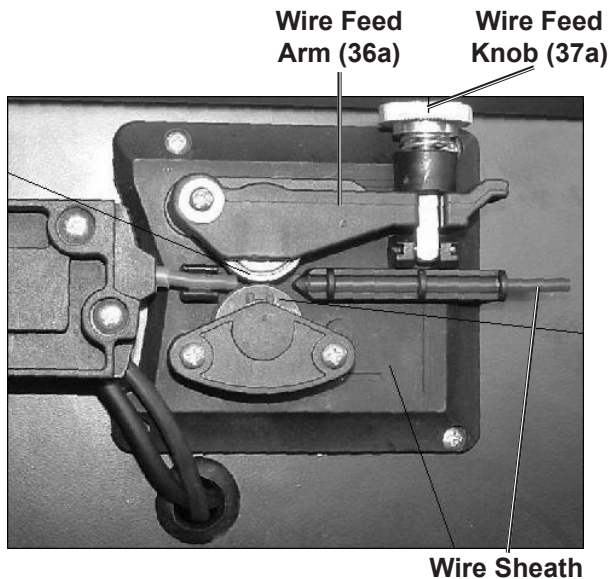

1. Press on the Cover Locking Spring (8), then lift the Cover (31) using Handle (30) to expose the Wire Feed Unit (23a).
2. Unscrew the Wing Nut (25) and remove the Reel Locking Knob (26).
3. Remove the empty Wire Reel (27).

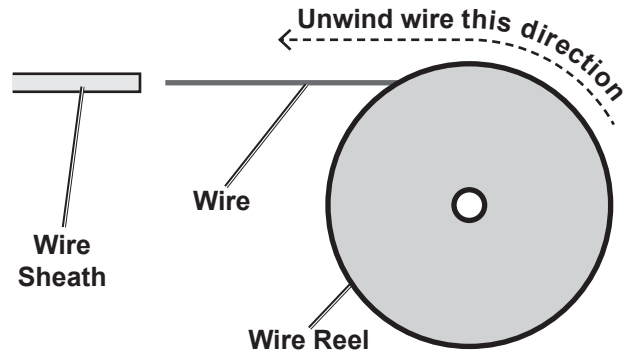

4. Place the new Wire Reel over the shaft and onto the Reel Spring (24). The wire on the reel should unwind counterclockwise so that it comes off the reel straight into the wire sheath, as illustrated above.
5. Replace the Reel Locking Knob and the Wing Nut. Tighten well.
6. Loosen the Wire Feed Knob (37a) and swing it off the Wire Feed Arm (36a) to remove tension.
7. If the end of the wire is crimped or bent, cut it off. Guide at least 12 inches of wire into the Wire Sheath.
8. Swing the Wire Feed Knob (37a) back onto the Wire Feed Arm (36a) and tighten it until the spring starts to compress.

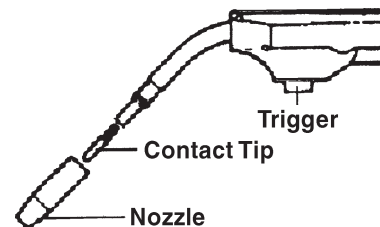

9. Turn the Torch Handle Nozzle counterclockwise and pull to remove.
10. Turn the Contact Tip counterclockwise and remove.

11. Lay the Torch Sheath out in a straight line so that the wire moves through it easily.

Warning: The following steps require applying power to the welder. Do not touch anything with the Torch Handle or an arc may be ignited.

12. Plug the Power Cord into its electrical outlet, press the Current Switch to Max., and turn the welder ON.
13. Lift the Torch Handle and continue pressing the Trigger until the wire feeds through two inches. If the wire does not feed, view the Wire Feed Unit and see if the wire is being pushed. If it is not, turn the welder OFF and tighten the Wire Feed Knob (37a).
14. Turn the welder ON again and press the Trigger.
15. Once the wire is exposed, turn the welder OFF and unplug it.
16. Slide the Contact Tip over the wire and screw it into Torch Handle.
17. Replace the Nozzle and cut off any excess wire over two inches.
18. Secure the Cover.

PLEASE READ THE FOLLOWING CAREFULLY

THE MANUFACTURER AND/OR DISTRIBUTOR HAS PROVIDED THE PARTS DIAGRAM IN THIS MANUAL AS A REFERENCE TOOL ONLY. NEITHER THE MANUFACTURER NOR DISTRIBUTOR MAKES ANY REPRESENTATION OR WARRANTY OF ANY KIND TO THE BUYER THAT HE OR SHE IS QUALIFIED TO MAKE ANY REPAIRS TO THE PRODUCT OR THAT HE OR SHE IS QUALIFIED TO REPLACE ANY PARTS OF THE PRODUCT. IN FACT, THE MANUFACTURER AND/OR DISTRIBUTOR EXPRESSLY STATES THAT ALL REPAIRS AND PARTS REPLACEMENTS SHOULD BE UNDERTAKEN BY CERTIFIED AND LICENSED TECHNICIANS AND NOT BY THE BUYER. THE BUYER ASSUMES ALL RISK AND LIABILITY ARISING OUT OF HIS OR HER REPAIRS TO THE ORIGINAL PRODUCT OR REPLACEMENT PARTS THERETO, OR ARISING OUT OF HIS OR HER INSTALLATION OF REPLACEMENT PARTS THERETO.

PARTS LIST AND DIAGRAMS

Parts list

Part	Description	Qty.
1	Torch	1
2	Contact Tip	1
3	Nozzle	1
4	Liner	1
5	Fixing Pole (A) for Gun Body	1
6	Fixing Pole (B) for Gun Body	1
7	Switch	2
8	Cover Locking Spring	1
9	Knob	1
10	Nut	1
11	Speed Control Circuit Board	1
12	Right Side Panel	1
13	Left Side Panel	1
14	Base Frame	1
15	Foot	4
16	Washer	4
17	Screw, ST 4.2 x 13	4
18	Transformer Carriage	2
19	Thermostat	1

Part	Description	Qty.
20	Transformer	1
21	Middle Partition Board	1
22	Overload Indicator Lamp	1
23a	Wire Feed Unit	1
24	Reel Spring	1
25	Wing Nut M6	1
26	Reel Locking Knob	1
27	Wire Reel	1
28	Reel Holder	1
29	Screw, ST 4.2 x 25	1
30	Handle	1
31	Cover	1
32	Power Cord	1
33	Ground Cable	1
34	Wire Feed Roller	1
35	Wire Feed Bearing	1
36a	Wire Feed Arm	1
37a	Wire Feed Knob	1

Record Product's Serial Number Here: _____

Note: If product has no serial number, record month and year of purchase instead.

Note: Some parts are listed and shown for illustration purposes only, and are not available individually as replacement parts.

REV 09e

SKU 94056

For technical questions, please call 1-800-444-3353.

Page 10

Assembly Diagram

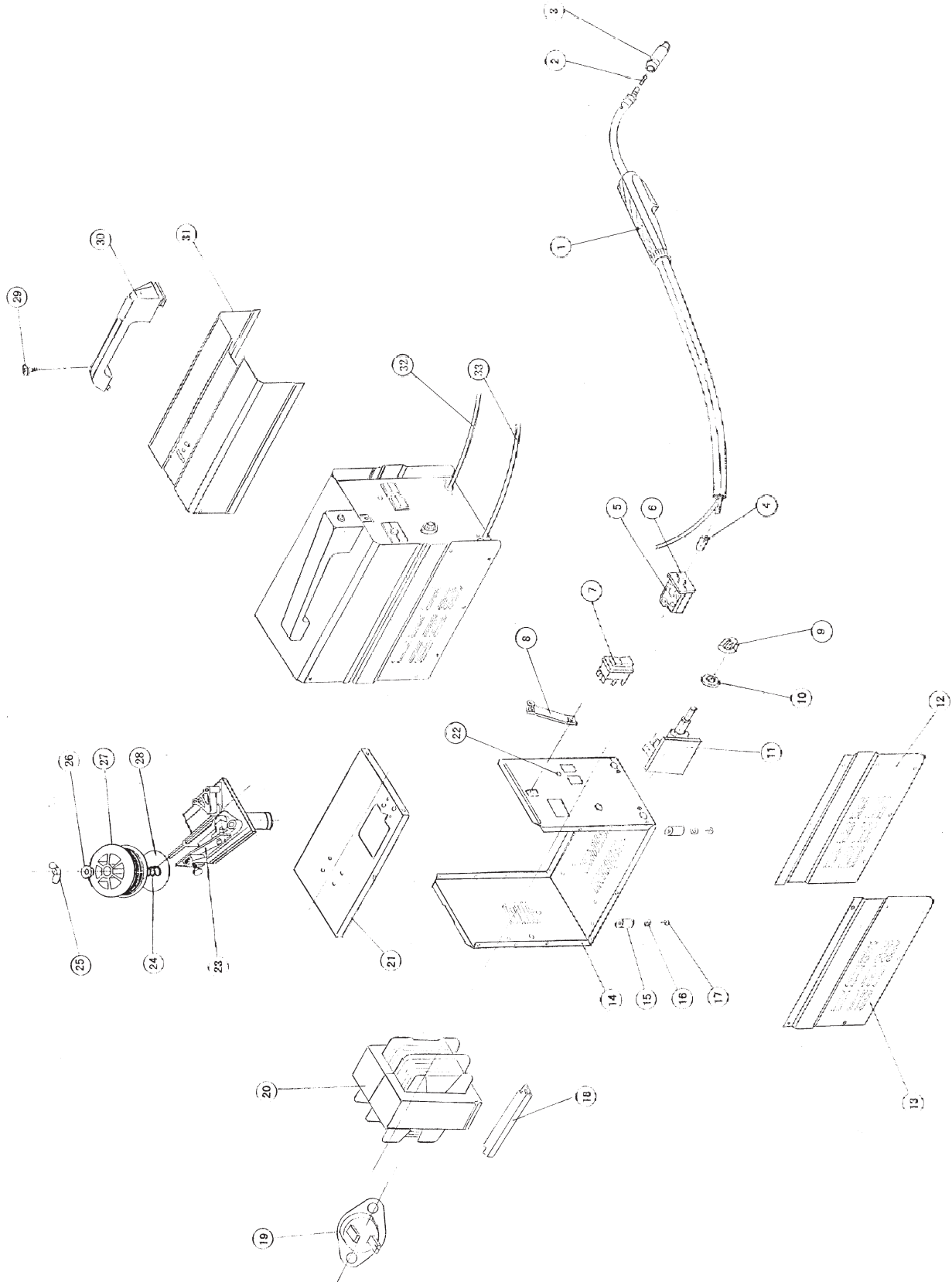

Welder Assembly Photographs

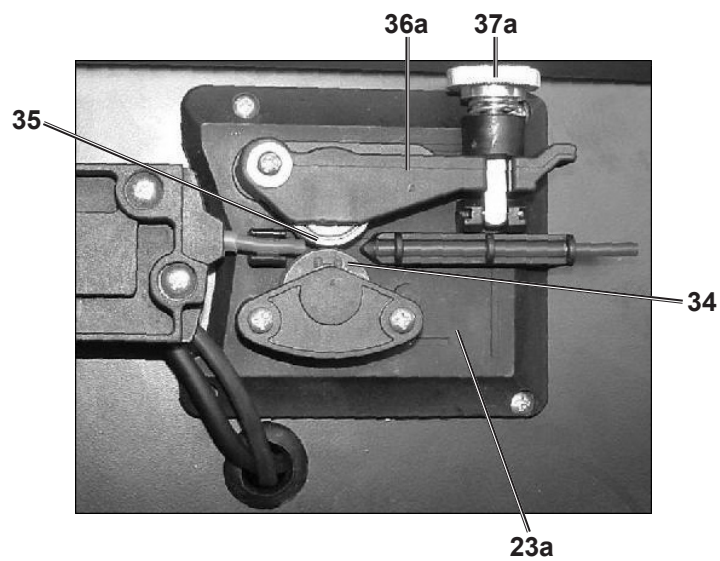
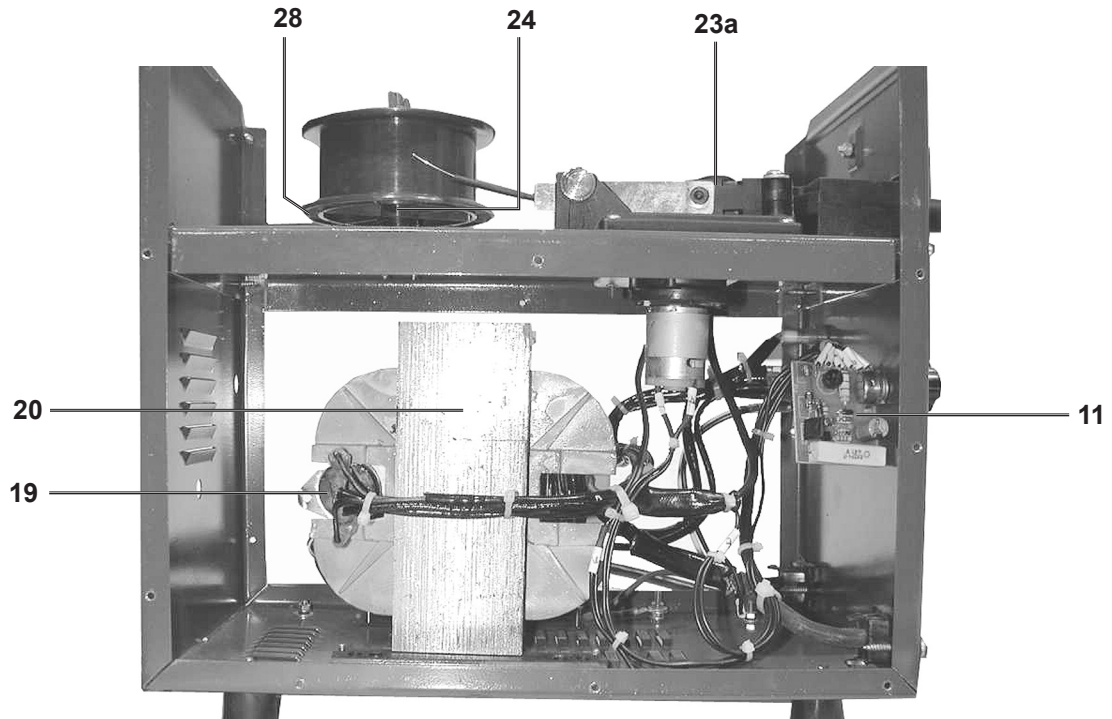

Wiring Schematic

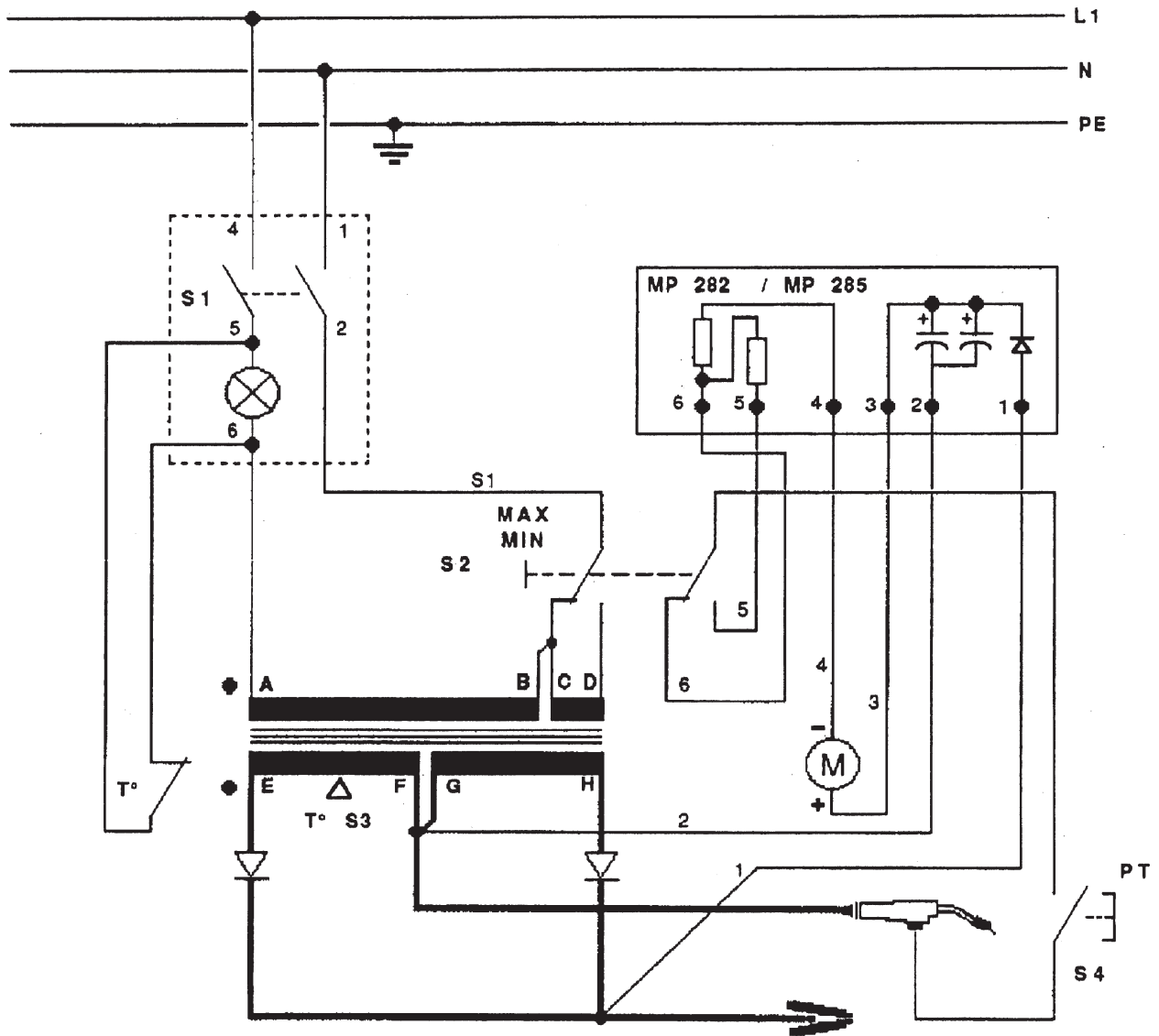

LIMITED 1 YEAR / 90 DAY WARRANTY

Harbor Freight Tools Co. makes every effort to assure that its products meet high quality and durability standards, and warrants to the original purchaser that for a period of ninety days from date of purchase that the torch, liner, wire feed mechanism (if applicable), welding clamps, electrode holders, cables and accessories packed with the welder are free of defects in materials and workmanship. **This**

Limited 90 Day/1 Year Warranty shall not apply to consumable parts such as tips, welding wire, and gas nozzles.

Harbor Freight Tools also warrants to the original purchaser, for a period of one year from date of purchase, that the transformer and rectifier are free from defects in materials and workmanship (90 days if used by a professional contractor or if used as rental equipment). This warranty does not apply to damage due directly or indirectly to misuse, abuse, negligence or accidents, repairs or alterations outside our facilities, normal wear and tear, or to lack of maintenance. We shall in no event be liable for death, injuries to persons or property, or for incidental, contingent, special or consequential damages arising from the use of our product. Some states do not allow the exclusion or limitation of incidental or consequential damages, so the above limitation of exclusion may not apply to you. THIS WARRANTY IS EXPRESSLY IN LIEU OF ALL OTHER WARRANTIES, EXPRESS OR IMPLIED, INCLUDING THE WARRANTIES OF MERCHANTABILITY AND FITNESS.

To take advantage of this warranty, the product or part must be returned to us with transportation charges prepaid. Proof of purchase date and an explanation

REV 061

SKU 94056

For technical questions, please call 1-800-444-3353.

Page 14

of the complaint must accompany the merchandise. If our inspection verifies the defect, we will either repair or replace the product at our election or we may elect to refund the purchase price if we cannot readily and quickly provide you with a replacement. We will return repaired products at our expense, but if we determine there is no defect, or that the defect resulted from causes not within the scope of our warranty, then you must bear the cost of returning the product.

This warranty gives you specific legal rights and you may also have other rights which vary from state to state.

**3491 Mission Oaks Blvd. • PO Box
6009 • Camarillo, CA 93011 • (800)
444-3353**

Free Manuals Download Website

<http://myh66.com>

<http://usermanuals.us>

<http://www.somanuals.com>

<http://www.4manuals.cc>

<http://www.manual-lib.com>

<http://www.404manual.com>

<http://www.luxmanual.com>

<http://aubethermostatmanual.com>

Golf course search by state

<http://golfingnear.com>

Email search by domain

<http://emailbydomain.com>

Auto manuals search

<http://auto.somanuals.com>

TV manuals search

<http://tv.somanuals.com>