

**CHICAGO**  
**Electric® Power Tools**

# 50 FT. DRAIN CLEANER WITH POWER FEED

**Model 66508**

## ASSEMBLY AND OPERATING INSTRUCTIONS



Visit our website at: <http://www.harborfreight.com>



**Read this material before using this product.  
Failure to do so can result in serious injury.  
SAVE THIS MANUAL.**

---

Copyright© 2008 by Harbor Freight Tools®. All rights reserved. No portion of this manual or any artwork contained herein may be reproduced in any shape or form without the express written consent of Harbor Freight Tools. Diagrams within this manual may not be drawn proportionally. Due to continuing improvements, actual product may differ slightly from the product described herein. Tools required for assembly and service may not be included.

**For technical questions or replacement parts, please call 1-800-444-3353.**

Revised Manual 09b, 09k

## SPECIFICATIONS

Electric Motor	1/3 HP 1785 RPM
Power Cord	#16 AWG X 3C, 6'4" long
Power Input	120 V~ / 60 Hz / 4.7 A (running)
Cable Type	Spring Steel with Coupler End 50' L x 1/2" Cable Diameter (0.123" Wire Diameter)
Pipe Compatibility	For use with pipes having 2" to 4" I.D.

**CAUTION: DO NOT USE THIS DRAIN CLEANER ON DRAIN LINES SMALLER THAN TWO INCHES. DAMAGE MAY OCCUR TO EQUIPMENT OR PIPES.**

## SAVE THIS MANUAL

You will need the manual for the safety warnings and precautions, assembly instructions, operating and maintenance procedures, parts list and diagram. Keep your invoice with this manual. Write the invoice number on the inside of the front cover. Keep the manual and invoice in a safe and dry place for future reference.

## GENERAL SAFETY RULES

### **WARNING!**

#### **READ AND UNDERSTAND ALL INSTRUCTIONS**

**Failure to follow all instructions listed below may result in electric shock, fire, and/or serious injury.  
SAVE THESE INSTRUCTIONS**

### Work Area

1. **Keep your work area clean and well lit.** Cluttered benches and dark areas invite accidents.
2. **Do not operate power tools in explosive atmospheres, such as in**

**the presence of flammable liquids, gases, or dust.** Power tools create sparks which may ignite the dust or fumes.

3. **Keep bystanders, children, and visitors away while operating a power tool.** Distractions can cause you to lose control. Protect others in the work area from debris such as chips and sparks. Provide barriers or shields as needed.

## Electrical Safety

1. **Avoid body contact with grounded surfaces such as pipes, radiators, ranges, and refrigerators.** There is an increased risk of electric shock if your body is grounded.
2. **Do not expose power tools to rain or wet conditions.** Water entering a power tool will increase the risk of electric shock.
3. **Grounded tools must be plugged into an outlet properly installed and grounded in accordance with all codes and ordinances.** Never remove the grounding prong or modify the plug in any way. Do not use any adapter plugs. Check with a qualified electrician if you are in doubt as to whether the outlet is properly grounded. If the tools should electrically malfunction or break down, grounding provides a low resistance path to carry electricity away from the user.
4. **Double insulated tools are equipped with a polarized plug (one blade is wider than the other).** This plug will fit in a polarized outlet only one way. If the plug does not fit fully in the outlet, reverse the plug. If it still does not fit, contact a qualified electrician to install a polarized outlet. Do not change the plug in any way. Double insulation

REV 09b, 09k

eliminates the need for the three wire grounded power cord and grounded power supply system.

5. **Do not abuse the Power Cord.** Never use the Power Cord to carry the tools or pull the Plug from an outlet. Keep the Power Cord away from heat, oil, sharp edges, or moving parts. Replace damaged Power Cords immediately. Damaged Power Cords increase the risk of electric shock.
6. **When operating a power tool outside, use an outdoor extension cord marked “W-A” or “W”.** These extension cords are rated for outdoor use, and reduce the risk of electric shock.

### Personal Safety

1. **Stay alert.** Watch what you are doing, and use common sense when operating a power tool. Do not use a power tool while tired or under the influence of drugs, alcohol, or medication. A moment of inattention while operating power tools may result in serious personal injury.
2. **Dress properly.** Do not wear loose clothing or jewelry. Contain long hair. Keep your hair, clothing, and gloves away from moving parts. Loose clothes, jewelry, or long hair can be caught in moving parts.
3. **Avoid accidental starting.** Be sure the Power Switch is off before plugging in. Carrying power tools with your finger on the Power Switch, or plugging in power tools with the Power Switch on, invites accidents.
4. **Remove adjusting keys or wrenches before turning the power tool on.** A wrench or a key that is left attached to a rotating part of the power tool may result in personal injury.

5. **Do not overreach.** Keep proper footing and balance at all times. Proper footing and balance enables better control of the power tool in unexpected situations.

6. **Use safety equipment.** Always wear eye protection. Dust mask, nonskid safety shoes, hard hat, or hearing protection must be used for appropriate conditions.

### Tool Use and Care

1. **Do not force the tool.** Use the correct tool for your application. The correct tool will do the job better and safer at the rate for which it is designed.
2. **Do not use the power tool if the Power Switch does not turn it on or off.** Any tool that cannot be controlled with the Power Switch is dangerous and must be replaced.
3. **Disconnect the Power Cord Plug from the power source before making any adjustments, changing accessories, or storing the tool.** Such preventive safety measures reduce the risk of starting the tool accidentally.
4. **Store idle tools out of reach of children and other untrained persons.** Tools are dangerous in the hands of untrained users.
5. **Check for misalignment or binding of moving parts, breakage of parts, and any other condition that may affect the tool’s operation.** If damaged, have the tool serviced before using. Many accidents are caused by poorly maintained tools.
6. **Use only accessories that are recommended by the manufacturer for your model.** Accessories that may be suitable for one tool may become hazardous when used on another tool.

## Service

7. **Tool service must be performed only by qualified repair personnel.** Service or maintenance performed by unqualified personnel could result in a risk of injury.
8. **When servicing a tool, use only identical replacement parts.** Follow instructions in the "Inspection, Maintenance, And Cleaning" section of this manual. Use of unauthorized parts or failure to follow maintenance instructions may create a risk of electric shock or injury.

---

## **SPECIFIC SAFETY RULES FOR THIS PRODUCT**

---

1. **Maintain labels and nameplates on the Drain Cleaner.** These carry important information. If unreadable or missing, contact Harbor Freight Tools for a replacement.
2. **Always wear ANSI-approved safety impact eye goggles and heavy, leather work gloves when using the Drain Cleaner.** Never grasp a rotating cable with a rag or cloth glove. Using personal safety devices reduce the risk for injury. Safety impact eye goggles and heavy work gloves are available from Harbor Freight Tools.
3. **Avoid unintentional starting.** Make sure you are prepared to begin work before turning on the Drain Cleaner.
4. **Do not force the Drain Cleaner.** This tool will do the work better and safer at the speed and capacity for which it was designed.
5. **Maintain a safe working environment.** Keep the work area well lit. Make sure there is adequate surrounding workspace. Always keep the work area free of obstructions, grease, oil, trash, and other debris. Do not use a power tool in areas near flammable chemicals, dusts, and vapors.
6. **Always unplug the Drain Cleaner from its electrical outlet before performing any inspection, maintenance, or cleaning procedures.**
7. **Never leave the Drain Cleaner unattended while running.** Turn power off if you have to leave the Drain Cleaner.
8. **Before each use, check all nuts, bolts, and screws for tightness.** Vibration during operation may cause these to loosen.
9. **Avoid electrical shock.** Do not operate the Drain Cleaner if sitting in standing water, and if the operator is in standing water. Keep extension cord off the ground and away from water. Water increases the risk of electric shock.
10. **Always connect the Line Cord to a Ground Fault Circuit Interrupter (GFCI) protected electrical outlet.**
11. **Install this product on a proper surface.** Locate on a flat, level, and solid surface that is capable of supporting the weight of the Drain Cleaner.
12. **Never operate the Drain Cleaner with the belt guard removed.** Fingers can get caught between the drive belt and pulley.
13. **Do not overstress cable.** Keep gloved hand on the cable for control when machine is running. In the course of drain cleaning, if the cable encounters an obstruction, it may stress the cable and cause the cable to twist, kink, or break. This may result in serious injury, and damage the equipment or pipes.
14. **Position Drain Cleaner within two feet of drain opening.** Greater dis-

tances can result in the cable twisting or kinking.

15. **For safest operation, the Drain Cleaner should be run only by the operator controlling the Foot Pedal and Cable.**
16. **Reversing the Motor direction should only be done when pulling the Cable out of the pipe, or off an obstruction.** Trying to push the Cable down the pipe while in reverse operation can result in Cable damage. Make sure Drum has stopped turning before changing the Motor Direction Switch (5).
17. **Keep hands away from the rotating Drum (38a) and Feed Pipe (42a).** Do not reach into Drum unless the Drain Clean power cord is unplugged.
18. **Avoid contact to eyes and skin of any drain cleaners that may have been used to unclog the drain previous to using the Drain Cleaner.** These chemicals can burn the eyes and skin. They may also damage the Cable.
19. **Be aware of possible damage to drain lines that may result from the discovery of roots and other obstacles.**
20. **⚠ WARNING! People with pacemakers should consult their physician(s) before using this product.** Electro-magnetic fields in close proximity to a heart pacemaker could cause interference to or failure of the pacemaker. In addition, people with pacemakers should adhere to the following:
  - Avoid operating power tools alone.
  - Properly maintain and inspect all tools before use to avoid electrical shock.

---

## GROUNDING

---

**⚠ WARNING** TO PREVENT ELECTRIC SHOCK AND DEATH FROM INCORRECT GROUNDING WIRE CONNECTION:



Check with a qualified electrician if you are in doubt as to whether the outlet is properly grounded. Do not modify the power cord plug provided with the tool. Never remove the grounding prong from the plug. Do not use the tool if the power cord or plug is damaged. If damaged, have it repaired by a service facility before use. If the plug will not fit the outlet, have a proper outlet installed by a qualified electrician.

---

### Grounded Tools: Tools with Three Prong Plugs

---

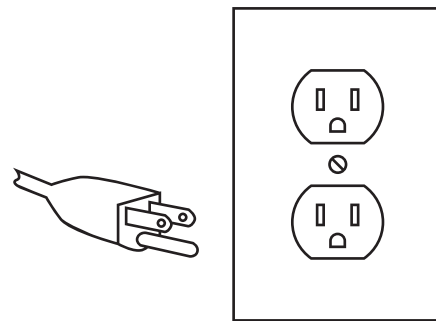

**3-Prong Plug and Outlet**

1. Tools marked with “Grounding Required” have a three wire cord and three prong grounding plug. The plug must be connected to a properly grounded outlet. If the tool should electrically malfunction or break down, grounding provides a low resistance path to carry electricity away from the user, reducing the risk of electric shock. **(See 3-Prong Plug and Outlet.)**



2. The grounding prong in the plug is connected through the green wire inside the cord to the grounding system in the tool. The green wire in the cord must be the only wire connected to the tool's grounding system and must never be attached to an electrically "live" terminal. **(See 3-Prong Plug and Outlet.)**
3. The tool must be plugged into an appropriate outlet, properly installed and grounded in accordance with all codes and ordinances. The plug and outlet should look like those in the preceding illustration. **(See 3-Prong Plug and Outlet.)**

### Double Insulated Tools: Tools with Two Prong Plugs

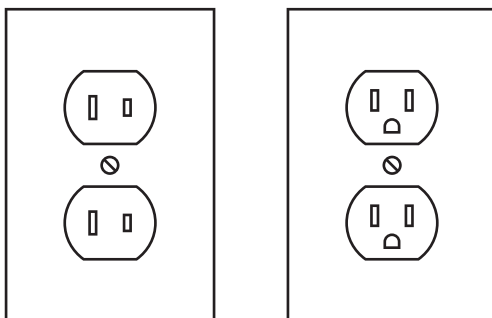

**Outlets for 2-Prong Plug**

4. Tools marked "Double Insulated" do not require grounding. They have a special double insulation system which satisfies OSHA requirements and complies with the applicable standards of Underwriters Laboratories, Inc., the Canadian Standard Association, and the National Electrical Code. **(See Outlets for 2-Prong Plug.)**
5. Double insulated tools may be used in either of the 120 volt outlets shown in the preceding illustration. **(See Outlets for 2-Prong Plug.)**
- 6.

### Ground Fault Circuit Interrupter (GFCI)

A Ground Fault Circuit Interrupter (GFCI) is manufactured within the Power Cord (15), about midway, due to the risk of electrical shock when operating the Drain Cleaner, and its proximity to water and ground. The GFCI provides additional protection from the risk of electrical shock.



1. Make sure that the Motor Direction Switch is in the Off position before plugging in the Drain Cleaner.
2. Plug the GFCI Power Plug into a grounded, 120 VAC electrical outlet.
3. Press the TEST button, then press the RESET button. The GFCI indicator should show Red in the window.

If the indicator is not red, try plugging the Power Cord into a different electrical outlet and repeat the steps. If the same results occur, have the Power Cord inspected by a licensed electrician. Repair or replacement must be completed by a licensed electrician.

**Note:** The Power Cord is not GFCI protected from the GFCI unit to the 3-prong plug in the electrical outlet.

### EXTENSION CORDS

1. **Grounded** tools require a three wire extension cord. **Double Insulated** tools can use either a two or three wire extension cord.
2. As the distance from the supply outlet increases, you must use a heavier gauge extension cord. Using extension cords with inadequately sized wire causes a serious drop in voltage,

resulting in loss of power and possible tool damage.







(See Figure C, next page.)

3. The smaller the gauge number of the wire, the greater the capacity of the cord. For example, a 14 gauge cord can carry a higher current than a 16 gauge cord. (See Figure C.)
4. When using more than one extension cord to make up the total length, make sure each cord contains at least the minimum wire size required. (See Figure C.)
5. If you are using one extension cord for more than one tool, add the nameplate amperes and use the sum to determine the required minimum cord size. (See Figure C.)
6. If you are using an extension cord outdoors, make sure it is marked with the suffix "W-A" ("W" in Canada) to indicate it is acceptable for outdoor use.
7. Make sure your extension cord is properly wired and in good electrical condition. Always replace a damaged extension cord or have it repaired by a qualified electrician before using it.
8. Protect your extension cords from sharp objects, excessive heat, and damp or wet areas.

RECOMMENDED MINIMUM WIRE GAUGE FOR EXTENSION CORDS* (120/240 VOLT)					
NAMEPLATE AMPERES (at full load)	EXTENSION CORD LENGTH				
	25'	50'	75'	100'	150'
0 – 2.0	18	18	18	18	16
2.1 – 3.4	18	18	18	16	14
3.5 – 5.0	18	18	16	14	12
5.1 – 7.0	18	16	14	12	12
7.1 – 12.0	18	14	12	10	-
12.1 – 16.0	14	12	10	-	-
16.1 – 20.0	12	10	-	-	-

**TABLE A** \* Based on limiting the line voltage drop to five volts at 150% of the rated amperes.

### Symbology

	Double Insulated
	Canadian Standards Association
	Underwriters Laboratories, Inc.
	Volts Alternating Current
	Amperes
	No Load Revolutions per Minute (RPM)

### UNPACKING

When unpacking, check to make sure that all the parts are included. Refer to the Assembly section, and the Assembly Drawing and Parts List at the end of this manual. If any parts are missing or broken, please call Harbor Freight Tools at the number on the cover of this manual as soon as possible.

---

# OPERATING INSTRUCTIONS

---

The following sections describe the operational components and controls of the Drain Cleaner, as well as its operation and application.

## Operational Components and Controls

**Warning: Do not allow your hands, clothing or any other object to become caught between the belt and the drum. Serious personal injury could result.**

1. The main operational components of the Drain Cleaner tool are the Motor (7), with its Motor Direction Switch (5), Pneumatic Foot Pedal (14A) and the Cable Feed Unit (44a) with its direction controller.
2. The **Motor** (7) is connected to the **Drum** (38a) using a **Drive Belt** (2). When turned on, the Motor turns the Drum, which causes the Spring Cable (39a) to rotate. Rotation of the Spring Cable helps it to move through bends or turns in the drain line, and also to drill through soft clogs, or entangle harder clogs for removal. (See photo below, left.)
3. The **Motor Direction Switch** (5) has NORMAL, UNBIND and OFF settings. NORMAL will set the Spring Cable to rotate clockwise (viewed from machine rear), causing it to bore into or entangle any obstruction. UNBIND will cause the Spring Cable to rotate counterclockwise (viewed from machine rear), causing it to unwind from any obstruction. (See photo below, right.)

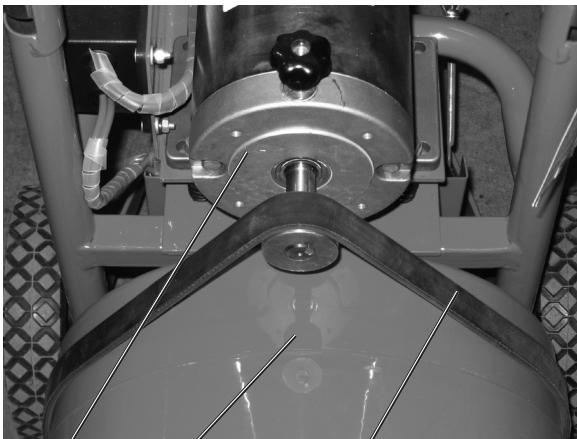

Motor (7), Drum (38a) and Drive Belt (2).



Motor Direction Switch (5)

4. The Motor is controlled by a **Pneumatic Foot Pedal** (14A). Whenever the Motor Direction Switch (5) is in the NORMAL or UNBIND position, stepping on the Pneumatic Foot Pedal (14A) will cause the motor to run and the Drum (38a) to turn. **NOTE:** The Foot Pedal is a Pneumatic Switch. (See photo on page 10, top-left.)
5. The rotating Drum causes the Spring Cable (39a) to rotate along its axis like a drill. The Direction Lever (44-16) on the Cable Feed Unit (44a) controls the motion of the Spring Cable (39a) forward into the drain or back into the Drum (38a). The feed tension is controlled by the Star Knob (44-13). See photo on page 10, top-right. The Star Knob (44-13) must be loosened before changing the position of the Direction Lever (44-16), and then retightened after the adjustment.

REV 09b





**Pneumatic Foot Pedal (14A):** Press On, release Off

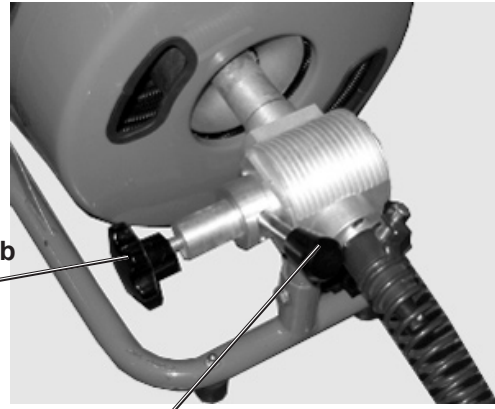

**Star Knob (44-13)**

**Direction Lever (44-16):** Pull Up: forward direction, Center: neutral; Push down: slow reverse, Fast reverse direction.

### **Attaching Guide Spring (48)**

While following these procedures, it may be helpful to refer to the Parts List and Assembly Drawings located at the end of this manual.

1. Unplug the Power Cord from the electrical outlet.
2. Pull up on the Direction Lever (44-16) to place it in the NEUTRAL position.
3. Loosen Tension Knob (44-13) and pull out three feet of cable from the Drum (38a).
4. Slide the Guide Spring (48) over the cable and onto the Adapter (44-3) on the end of the Cable Feed Unit.
5. Pull out and align the Spring Loaded Pin (46) on the Guide Spring, with the hole in the Adapter (44-3).
6. Retighten Tension Knob (44-13).

### **Select and Attach Proper Cutting Tool**

There are four Cutting Tools included with the Drain Cleaner. Select the appropriate tool for the cleaning job and attach to Cable (39a). Each is described in the table below.

<b>Cutter Tool</b>	<b>Application</b>
Arrow Cutting Head (59)	Starting tool for cutting and scraping
Auger Bulb (60)	Starting tool to remove loose objects
1-1/2" U-Cutter (61)	Finishing tool for grease stoppages and scraping pipe walls
1-1/4" Side Cutter Blade (62)	Starting / Finishing tool to remove loose objects and scraping pipe walls

1. Select the desired cutter tool and insert it into the female connector located at the end of the Cable (39a). It is recommended to start with the Arrow Cutting Head (59) or Auger Bulb (60). Once the drainpipe is opened, then use the 1-1/2 U-Cutter (61) or 1-1/4" Side Cutter Blade (62) to scrape the inside wall of the drain pipe, for a more

thorough cleaning job. Secure the cutter tool to Cable (39a) with Phillips Screw (78) and Spring Washer (77).

## Drain Cleaning Operation

**CAUTION:** DO NOT USE THIS DRAIN CLEANER ON DRAIN LINES SMALLER THAN TWO INCHES. DAMAGE MAY OCCUR TO EQUIPMENT OR PIPES.

1. Place the Drain Cleaner within two feet of the drain pipe inlet.
2. Pull Cable (39a) from the Drum (38a) and begin feeding it into the drain pipe inlet as far as it will go manually.
3. Verify that the Motor Direction Switch (5) is in the Off position, then plug the Power Cord (15) into an electrical outlet. Press the Reset button on the GFCI.
4. Loosen the Star Knob (44-13) by turning it counterclockwise until it is no longer pressing against the cable. See photo on page 10.
5. Pull the Direction Lever (44-16) up (FORWARD) to feed Cable out of the Drum. Pushing the Direction Lever down (REVERSE) will retract the Cable back into the Drum. When the lever is in the middle (NEUTRAL) position, the Cable will spin in place.
6. Move the Motor Direction Switch (5) to the Forward position. **CAUTION: Do not force the Cable.** Let the cutter do the work.
7. Turn (clockwise) the Star Knob (44-13), at the top of the Cable Feed Unit, until the feed roller touches the Cable, then one quarter additional turn. Do not overtighten, excessive cable wear will occur. See photo on page 10.
8. Wearing a leather glove, place your hand on the Guide Tube or Cable, press the Pneumatic Foot Pedal (14A) to start the forward Cable movement. Feed the Cable into the drain pipe inlet with a firm and even pressure against any resistance. Adjust the feeding rate to the resistance met. Do not force the Cable. Let the cutter do the work. Run hot water down the drain pipe during and after the removal of the stoppage to wash away debris.
9. **WARNING!** If the drain cleaner stops suddenly, switch it off immediately. Allow motor to cool off completely before restarting and stay clear of cable when turning motor back on.
10. After the drain pipe has been opened, return the cable to the Drum. To do that: Place the Direction Lever (44-16) in the UNBIND direction. Press the Motor Direction Switch (5) to the NORMAL position. Press on the Pneumatic Foot Pedal (14A) to recoil Cable. When the cutter head is near the drain pipe inlet, release Foot Pedal to stop Drum rotation. NOTE: If necessary, replace the cutter tool with the U-Cutter or Side Cutter, and reenter the drain pipe to clean the pipe walls.
11. **Caution:** Avoid damage to Cable or cutting tool. Do not use the Motor Direction Switch (5) in the Reverse position to pull the Cable out of the drain pipe. Always leave the

Switch (5) in the NORMAL position, whether feeding the Cable into the drain pipe, or pulling it out. Use Reverse position only to release the Cable if it should become caught in the drain pipe line, and only for a few seconds.

12. When the job is complete, unplug the Power Cord from the electrical outlet and coil it. Store the Drain Cleaner and cutter tools in clean and dry location.

### OPERATING TIPS

When Cable starts to bend, twist or whip.	Too much slack in Cable or cutter tool caught in stoppage. Release Foot Pedal, press Direction Lever down to temporarily reverse cable feed direction, and re-wind to relieve twist on Cable. Pull Direction Lever up (FORWARD) to continue.
When Cable has trouble getting around tight bends in drain pipe.	Press Motor Direction Switch (5) to Reverse while applying steady pressure to Cable. Keep in mind that this will reverse auto feed operation as well. Do for only a few seconds to pass bend. More time could cause tangling or kinks in the Drum. If problem persists, Cable is too large for pipe. Switch to a drain cleaner with a smaller cable.
When Cable reaches clog in drain pipe.	Do not force Cable through stoppage. Press Direction Lever to neutral position. Allow Cable to progress forward slowly, chewing stoppage. Slow forward movement reduces stress on Cable, while cleaning better. Try back and forth Cable movement, using the Direction Lever (44-16).

### TROUBLESHOOTING

Problem	Probable Cause(s)	Solution(s)
Motor cuts off during use.	The motor may have been shut off by it's internal thermal protection switch, or auto reset breaker.	Turn motor off. Allow motor to cool off completely before restarting and stay clear of cable when turning motor back on.
Cable kinks, twists, or breaks.	<ol style="list-style-type: none"> <li>1. Too much force on the cable.</li> <li>2. Too much slack between Drain Cleaner and drainpipe inlet.</li> <li>3. Cable used is wrong size for drain pipe.</li> <li>4. Cable exposed to acid.</li> <li>5. Cable worn out.</li> </ol>	<ol style="list-style-type: none"> <li>1. Do not force cable. Let cutter tool do the work.</li> <li>2. Move Drain Cleaner to within two feet of drainpipe inlet.</li> <li>3. Change cable size.</li> <li>4. Clean and oil cable regularly.</li> <li>5. Replace cable</li> </ol>
Cable tangles in drum.	<ol style="list-style-type: none"> <li>1. Too much force on the cable.</li> <li>2. Motor running in reverse.</li> <li>3. Distributor tube frozen.</li> </ol>	<ol style="list-style-type: none"> <li>1. Do not force cable. Let cutter tool do the work.</li> <li>2. Retract Cable with the Motor Direction Switch (5) in the Forward position.</li> <li>3. Lubricate distributor tube bearings.</li> </ol>

## TROUBLESHOOTING

Problem	Probable Cause(s)	Solution(s)
Power Cord GFCI trips when unit is plugged in or when Foot Pedal is pressed.	<ol style="list-style-type: none"> <li>1. Motor Direction Switch (5) defective.</li> <li>2. Frayed Power Cord.</li> <li>3. Short circuit in Motor.</li> <li>4. Excess moisture touching Power Cord or Drain Cleaner.</li> <li>5. Faulty GFCI unit.</li> </ol>	<ol style="list-style-type: none"> <li>1. Repair or replace Motor Direction Switch.</li> <li>2. Repair or replace Power Cord.</li> <li>3. Have Motor repaired by a qualified technician; Replace Motor.</li> <li>4. Remove moisture.</li> <li>5. Replace Power Cord with GFCI.</li> </ol>
Motor does not operate.	Pneumatic Foot Pedal may have a leak.	Check for leaks in air line leading from Foot Pedal. Check for tears and holes in Foot Pedal. Replace if needed.
The "Unbind/Normal" Switch does not work.	The centrifugal switch requires the motor to come to a complete stop before it will allow the direction of the motor to be changed.	Move the "Unbind/Normal" Switch to the "Off" position and allow the motor to stop before changing from "Normal to Unbind" or visa versa.
The Foot Pedal sticks.	Overloading of the motor may cause the Foot Pedal to stick.	Press the Foot Pedal several times to release it.
Cable does not feed when Foot Pedal is pressed.	<ol style="list-style-type: none"> <li>1. Cable tangled in Drum.</li> <li>2. Feed tension incorrect.</li> <li>3. Feed roller frozen.</li> <li>4. Cable worn out.</li> </ol>	<ol style="list-style-type: none"> <li>1. Do not run Motor in reverse. Unplug Drain Cleaner and manually pull cable out until tangle is cleared.</li> <li>2. Adjust feed tension Star Knob (44-13). If Knob is too loose, cable will slip. If too tight, rollers will wear prematurely.</li> <li>3. Clean and lubricated feed rollers. Replace worn rollers.</li> <li>4. When cable coils wear flat, cable should be replaced.</li> </ol>

---

## INSPECTION, MAINTENANCE, AND CLEANING

---

 **WARNING!** Make sure the Power Switch of the Drain Cleaner is in its “OFF” position and that the tool is unplugged from its electrical outlet before performing any inspection, maintenance, or cleaning procedures.

### General

1. **Before each use**, inspect the general condition of the Drain Cleaner. Check for loose screws, misalignment or binding of moving parts, cracked or broken parts, damaged electrical wiring, and any other condition that may affect its safe operation. If abnormal noise or vibration occurs, have the problem corrected before further use. **Do not use damaged equipment.**
2. Periodically recheck all nuts, bolts, and screws for tightness.
3. After each use, clean the Drain Cleaner components with a wet, clean cloth. Wipe dry when clean.
4. Always keep Cable (39a) well oiled by pouring oil directly into the Drum (38a). Then push the Motor Direction Switch (5) to the NORMAL position. The Drum will rotate. Do this until the entire Cable is lubricated. Lubricate all other moving parts adequately to protect against corrosion, sand, grit, and other abrasive material.
5. Store unit in a clean and dry location. Cover unit with a cloth cover.
6. The cable includes a Cable Stop (80) to prevent it from being overextended. Loosen the Bolts (81), and remove Stop if removing the cable. When re-installing Cable, reattach the Stop inside the drum when there are about two full turns of cable still in the drum.

### Auto Feed Maintenance

Keep the auto feed mechanism free of excessive soil and grit. It is recommended that it be flushed with fresh water, followed by a light oiling of the moving parts. No disassembly is normally required. Failure to feed during operation can usually be traced to the build up of soil and grit. Over time, dirt can harden enough to stop roller rotation. **Flushing with water, followed by liberal oiling can usually restore function.** If disassembly is required, proceed as follows:

1. Remove the two bolts that hold the Front Cap (44-19A) and internal roller to the Case (44-11A).
2. Slide the front Cap out of the Case and inspect and clean the roller as described above.
3. Remove the four bolts that hold the End Cap (44-7A) and Guide Rollers (44-9) to the Case (44-11A).
4. Slide the End Cap out of the Case and inspect and clean the three guide rollers as described above.



5. While the Case is open, thoroughly clean and oil all parts and then reassemble in reverse order.

### **Guide Roller Replacement**

Guide Rollers (44-9) due to excessive use may be damaged to a point of failure and need replacement. Replace all three Guide Rollers at the same time.

### **Tangled Cable**

If the Cable loops over itself in the Drum, it will not feed properly. With the motor stopped and cord unplugged, remove and reload the Cable by hand to restore proper functioning. If the Cable kinks, it is evidence of abuse and results from the use of too much pressure when drain cleaning, or use of the wrong size Cable for the drain pipe being cleaned. Do not force the Cable during use, let the cutter tool do the work.

### **Removing a Stuck Cable in the Drain Pipe**

1. If the cable gets caught in the drain pipe move the Motor Direction Switch (5) to the Off position. Then, once the drum has stopped turning, move the Motor Direction Switch (5) to the Reverse position to free the Cable.
2. If using the Power Cable Feed, putting the Motor in reverse will cause the feed Direction Lever (44-16) to operate opposite of normal.
3. Press the Pneumatic Foot Pedal (14A) while pulling on the Cable.
4. After the Cable is loose, move the Motor Direction Switch (5) back to the Forward position.

**Caution: Running the Motor in reverse for more than a few seconds at a time can cause the Cable to tangle in the Drum.**

---

## **PLEASE READ THE FOLLOWING CAREFULLY**

---

THE MANUFACTURER AND/OR DISTRIBUTOR HAS PROVIDED THE PARTS DIAGRAM IN THIS MANUAL AS A REFERENCE TOOL ONLY. NEITHER THE MANUFACTURER NOR DISTRIBUTOR MAKES ANY REPRESENTATION OR WARRANTY OF ANY KIND TO THE BUYER THAT HE OR SHE IS QUALIFIED TO MAKE ANY REPAIRS TO THE PRODUCT OR THAT HE OR SHE IS QUALIFIED TO REPLACE ANY PARTS OF THE PRODUCT. IN FACT, THE MANUFACTURER AND/OR DISTRIBUTOR EXPRESSLY STATES THAT ALL REPAIRS AND PARTS REPLACEMENTS SHOULD BE UNDERTAKEN BY CERTIFIED AND LICENSED TECHNICIANS AND NOT BY THE BUYER. THE BUYER ASSUMES ALL RISK AND LIABILITY ARISING OUT OF HIS OR HER REPAIRS TO THE ORIGINAL PRODUCT OR REPLACEMENT PARTS THERETO, OR ARISING OUT OF HIS OR HER INSTALLATION OF REPLACEMENT PARTS THERETO.

## MAIN UNIT PARTS LIST

Part	Description	Qty	Part	Description	Qty
1	Protect Shield	1	42A	Cable Guide	1
2	Belt	1	44A	Feed Unit	1
3	Belt Wheel	1	45	Retaining Ring	2
4	Bolt M6 x 10	1	46	Pin	1
5	Motor Direction Switch	1	47	Pin Spring	1
6	Lock Nut M6	1	48	Guide Spring	1
7	Motor	1	54	Spring Washer Ø10	2
8	Lock Nut M10	4	55	Notched Washer	1
9A	Motor Holder	1	56	Inner Hex Bolt M8 x 8	2
10	Spring	4	57	Right Angle Guide	1
14A	Pneumatic Foot Switch	1	58	Cross-Head Bolt M5 x 10	1
15	GFCI	1	59	Arrow Head Cutter	1
16A	U Handle	1	60	Bulb Auger	1
17	Star Knob M10 x 35	2	61	1-1/2" U-Cutter	1
18A	Frame	1	62	1-1/4" Side Cutter Blade	2
20	Cotter Pin Ø3.2 x 25	2	63	Hex Bolt M10 x 70	4
21	Pipe Cap	2	64	Flat Washer 6	1
22	Wheel	2	65	Block	4
23	Washer Ø14	4	66	Hinge A	2
25	Hex Bolt M10 x 20	2	67	Inner Hex Bolt M4 x 25	4
26	Star Nut M10	1	68	Hinge B	2
27	Cap Nut M6	2	69	Tray	1
28	Rubber Foot	2	70	Washer #2	2
29	Washer Ø6	4	71	Cross-head Bolt M6 x 20	4
30	Phillips Bolt M6 x 40	2	72	Sleeve	2
31	Bolt M10 x 50	1	73	Wheel Shaft Cap	2
32	Washer Ø10	14	74	Waveform Washer 19	1
33A	Axle for Drum	1	75	Washer	1
35	Washer #1	1	76	Spring Washer 5	1
36	Lock Nut M8	5	77	Spring Washer 6	5
37A	Drum Hub	1	78	Phillips Screw M6X16	1
38A	Drum	1	79	Washer	1
39A	Spring Cable	1	80	Cable Stop	1
41	Hex Bolt M8 x 20	5	81	Inner Hex Screw M4X12	4

**NOTE:** Some parts are listed and shown for illustration purposes only and are not available individually as replacement parts.



## PARTS LIST FOR SUBASSEMBLY NO. 44A (FEED UNIT)

Part	Description	Q'ty
44-1	Base	1
44-2	Inner Hex Bolt M6x14	6
44-3	Adapter	1
44-4A	Axle for Guide Roller	1
44-5A	Guide Screw	1
44-6	Cable Sleeve	1
44-7A	End Cap	1
44-8A	Screw	4
44-9	Guide Roller	3
44-10A	Screw	2
44-11A	Case	1
44-12A	Side Cap	1
44-13	Star Knob M12	1
44-14A	Shaft	1
44-15	Shaft Sleeve	1

Part	Description	Q'ty
44-16	Direction Lever	1
44-17	Handle Cap	1
44-18	Spring	1
44-19A	Front Cap	1
44-20	Bolt M6x16	2
44-21	Inner Hex Bolt M6x18	4
44-22	Cap	1
44-23	Small Spring	1
44-24	Nylon Sleeve	2
44-25	Steel Ball Ø10	1
44-26	Spring Washer Ø6	6
44-29	O-ring	8
44-30	Washer Ø8	2
44-31	Pin 3X10	1
44-32	Flat Washer 6	6

## SUBASSEMBLY NO. 44A (FEED UNIT)

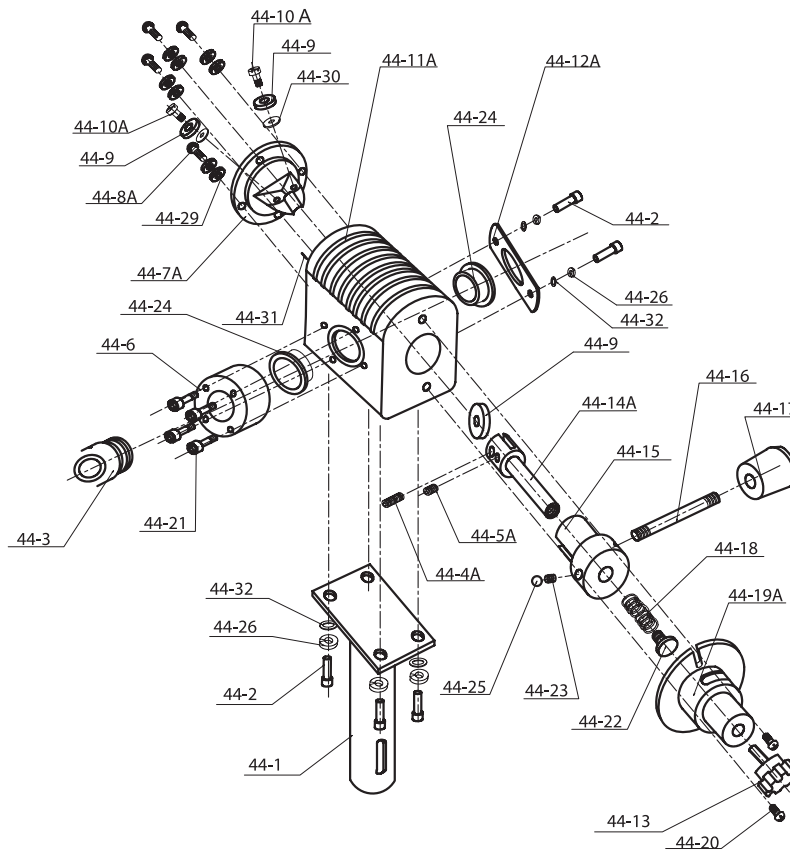

---

## LIMITED 90 DAY WARRANTY

---

Harbor Freight Tools Co. makes every effort to assure that its products meet high quality and durability standards, and warrants to the original purchaser that this product is free from defects in materials and workmanship for the period of 90 days from the date of purchase. This warranty does not apply to damage due directly or indirectly, to misuse, abuse, negligence or accidents, repairs or alterations outside our facilities, criminal activity, improper installation, normal wear and tear, or to lack of maintenance. We shall in no event be liable for death, injuries to persons or property, or for incidental, contingent, special or consequential damages arising from the use of our product. Some states do not allow the exclusion or limitation of incidental or consequential damages, so the above limitation of exclusion may not apply to you. THIS WARRANTY IS EXPRESSLY IN LIEU OF ALL OTHER WARRANTIES, EXPRESS OR IMPLIED, INCLUDING THE WARRANTIES OF MERCHANTABILITY AND FITNESS.

To take advantage of this warranty, the product or part must be returned to us with transportation charges prepaid. Proof of purchase date and an explanation of the complaint must accompany the merchandise. If our inspection verifies the defect, we will either repair or replace the product at our election or we may elect to refund the purchase price if we cannot readily and quickly provide you with a replacement. We will return repaired products at our expense, but if we determine there is no defect, or that the defect resulted from causes not within the scope of our warranty, then you must bear the cost of returning the product.

This warranty gives you specific legal rights and you may also have other rights which vary from state to state.

**3491 Mission Oaks Blvd. • PO Box 6009 • Camarillo, CA 93011 • (800) 444-3353**



## Free Manuals Download Website

<http://myh66.com>

<http://usermanuals.us>

<http://www.somanuals.com>

<http://www.4manuals.cc>

<http://www.manual-lib.com>

<http://www.404manual.com>

<http://www.luxmanual.com>

<http://aubethermostatmanual.com>

Golf course search by state

<http://golfingnear.com>

Email search by domain

<http://emailbydomain.com>

Auto manuals search

<http://auto.somanuals.com>

TV manuals search

<http://tv.somanuals.com>