

CHICAGO[®]

Electric

SEWING MACHINE - SINGLE NEEDLE

Model 3914

ASSEMBLY AND OPERATION INSTRUCTIONS



Due to continuing improvements, actual product may differ slightly from the product described herein.



3491 Mission Oaks Blvd., Camarillo, CA 93011

Visit our website at: <http://www.harborfreight.com>

**TO PREVENT SERIOUS INJURY, READ AND UNDERSTAND
ALL WARNINGS AND INSTRUCTIONS BEFORE USE.**

Copyright© 2005, 2007 by Harbor Freight Tools®. All rights reserved. No portion of this manual or any artwork contained herein may be reproduced in any shape or form without the express written consent of Harbor Freight Tools.

For technical questions or replacement parts, please call 1-800-444-3353.

Specifications

Machine Type	Heavy duty, industrial sewing machine; high speed, single needle-lock stitch
Drive	V-belt driven
Action	Foot pedal operation, along with a knee and manual lifting arm for presser foot. Presser tension adjustment
Feed Type	Link style needle feed
Sewing Directions	Forward and reverse feed
Machine Dimensions	20- ³ / ₄ " L x 10" H
Accessories	- 2 Screwdrivers- 3 Bobbins- Small lubricating bottle with tip- Spare needles- Power Switch
Table Stand Kit	Table Stand Kit (Model 03929) not included
Stitching Speed	5,500 SPM
Motor Type	Clutch motor; 3,450 RPM, 5.8/2.9 amps, 110/220 VAC, 60 Hz; single phase
Sewing Thickness	up to ⁵ / ₁₆ "
Overall weight	61.6 lb.

Warning: Make certain that the voltage switch on the motor is set correctly for your use. See page 6.

This Machine requires oil to be added before use -see page 6 for details.

Save This Manual

You will need the manual for the safety warnings and precautions, assembly instructions, operating and maintenance procedures, parts list and diagram. Keep your invoice with this manual. Write the invoice number on the inside of the front cover. Keep the manual and invoice in a safe and dry place for future reference.

Safety Warnings and Precautions

WARNING: When using tool, basic safety precautions should always be followed to reduce the risk of personal injury and damage to equipment.

Read all instructions before using this tool!

1. **Keep work area clean.** Cluttered areas invite injuries.
2. **Observe work area conditions.** Do not use machines or power tools in damp or wet locations. Don't expose to rain. Keep work area well lighted. Do not use electrically powered tools in the presence of flammable gases or liquids.
3. **Keep children away.** Children must never be allowed in the work area. Do not let them handle machines, tools, or extension cords.
4. **Store idle equipment.** When not in use, tools must be stored in a dry location to inhibit rust. Always lock up tools and keep out of reach of children.
5. **Use the right product for the job.** Do not attempt to force a small product or attachment to do the work of a larger industrial tool. There are certain applications for which this product was designed. It will do the job better and more safely at the rate for which it was intended. Do not modify this product and do not use this product for a purpose for which it was not intended.

6. **Dress properly.** Do not wear loose clothing or jewelry as they can be caught in moving parts. Protective, electrically nonconductive clothes and nonskid footwear are recommended when working. Wear restrictive hair covering to contain long hair.
7. **Do not overreach.** Keep proper footing and balance at all times. Do not reach over or across running machines.
8. **Maintain tools with care.** Keep needles sharp and tools clean for better and safer performance. Follow instructions for lubricating and changing accessories. Inspect tool cords periodically and, if damaged, have them repaired by a qualified technician. The handles must be kept clean, dry, and free from oil and grease at all times.
9. **Disconnect power.** Always turn the machine off and, if possible, disconnect the power plug of the machine from the receptacle before adjusting, repairing, or cleaning the machine; leaving the machine unattended; tilting the machine head; or removing the V-belt.
10. **Remove adjusting keys and wrenches.** Check that keys and adjusting wrenches are removed from the machine work surface before plugging it in.
11. **Avoid unintentional starting.** Be sure the switch is in the Off position when not in use and before plugging in.
12. **Stay alert.** Watch what you are doing, use common sense. Do not operate when you are tired.
13. **Check for damaged parts.** Before using any product, any part that appears damaged should be carefully checked to determine that it will operate properly and perform its intended function. Check for alignment and binding of moving parts; any broken parts or mounting fixtures; and any other condition that may affect proper operation. Any part that is damaged should be properly repaired or replaced by a qualified technician. Do not use if any switch does not turn On and Off properly.
14. **Guard against electric shock.** Prevent body contact with grounded surfaces such as pipes, radiators, ranges, and refrigerator enclosures.
15. **Replacement parts and accessories.** When servicing, use only identical replacement parts. Use of any other parts will void the warranty. Only use accessories intended for use with this tool. Approved accessories are available from Harbor Freight Tools.
16. **Do not operate tool if under the influence of alcohol or drugs.** Read warning labels if taking prescription medicine to determine if your judgment or reflexes are impaired while taking drugs. If there is any doubt, do not operate the tool.
17. **Use proper size and type extension cord.** If an extension cord is required, it must be of the proper size and type to supply the correct current to the tool without heating up. Otherwise, the extension cord could melt and catch fire, or cause electrical damage to the tool. This tool requires use of an extension cord with up to **10 amps** capability (up to 50 feet), with wire size rated at **18 AWG**. Longer extension cords require larger size wire. If you are using the tool outdoors, use an extension cord rated for outdoor use (signified by "WA" on the jacket).
20. **Maintenance.** For your safety, service and maintenance should be performed regularly by a qualified technician.
21. **Pacemaker safety warning.** People with pacemakers should consult with their

physician(s) before using this product; operation of electrical equipment in close proximity to a heart pacemaker could cause interference to or failure of the pacemaker.

Note: Performance of this tool may vary depending on variations in local line voltage. Extension cord usage may also affect tool performance.

Warning: The warnings, cautions, and instructions discussed in this instruction manual cannot cover all possible conditions and situations that may occur. It must be understood by the operator that common sense and caution are factors which cannot be built into this product, but must be supplied by the operator.

Sewing Safety Precautions

1. Keep hands away from the needle when you turn the power switch on, or while the machine is operating.
2. Do not place your fingers into the thread take-up cover while the machine is operating.
3. Never leave the machine running and unattended.
4. During operation, never place your head, hair, or hands in the proximity of the hand wheel, V-belt, bobbin winder, or motor.
5. Do not operate the machine with any safety guards removed.
6. This machine shall only be operated by appropriately trained operators.
7. For your personal protection, we recommend you wear ANSI approved safety glasses when using the machine.
8. If oil or grease comes in contact with your eyes or skin, immediately wash the affected areas and consult a physician.
9. Tampering, modifying or altering any device (aside from the cord and plug by a licensed electrician) on the machine is prohibited and will void manufacturer's warranty.
10. Repair, adjustment, and specific maintenance shall only be performed by a qualified service technician. Alteration or replacement of the 3 prong grounded electrical plug provided with the machine must only be performed by a licensed electrician. This machine must be properly grounded.
11. This sewing machine is only to be used for the purpose intended.

Unpacking

When unpacking, check to make sure that the parts shown in the photo on the following page are included. Note that the machine table shown is not included, and must be ordered separately. If any parts are missing or broken, please call Harbor Freight Tools at the number on the cover of this manual as soon as possible.

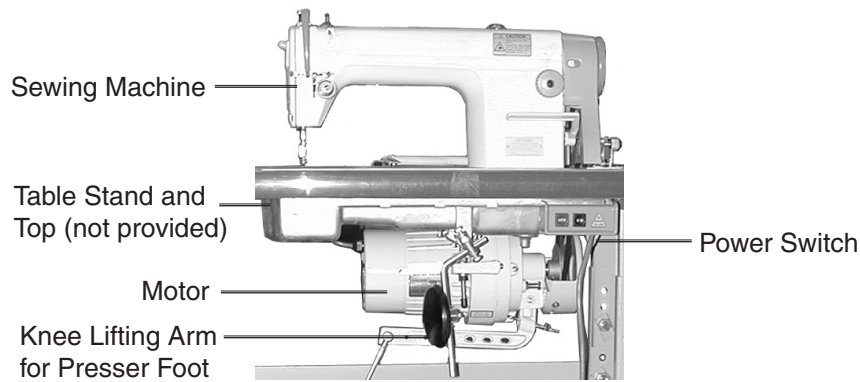

Assembly

The assembly instructions describe mounting the Single-Needle Sewing Machine (Model 03914) to the Table Stand (Model 03929), not included. In order to complete this procedure, you must first purchase and assemble the Table Stand Kit (Model 03929).

1. Locate four corner rests in the rectangular hole of the Table Stand where the machine will sit.
2. Place two rubber seats (A) on the operator-side, corner rests and secure with supplied hardware (C). See figure 1.
3. Place two cushion seats (B) on the hinge-side, corner rests and secure with supplied hardware (C).
4. Seat the Oil Pan (D) on the corner seats (A) and (B). See figure 2.

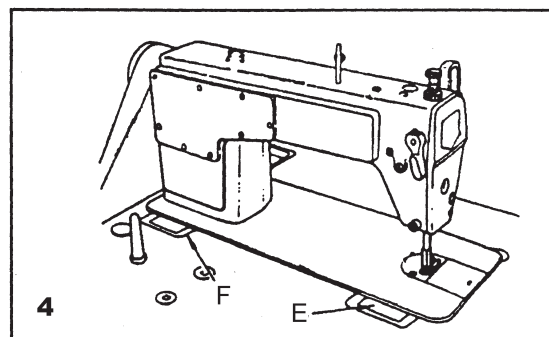
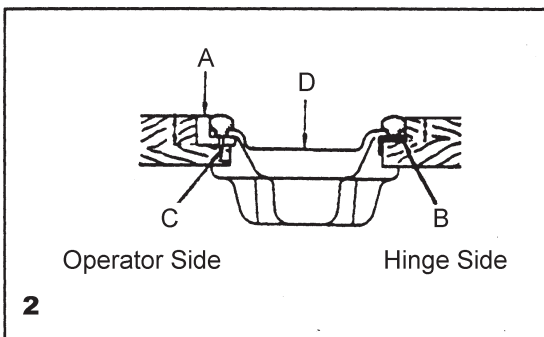
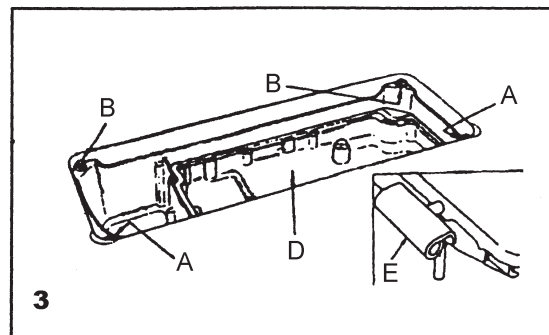
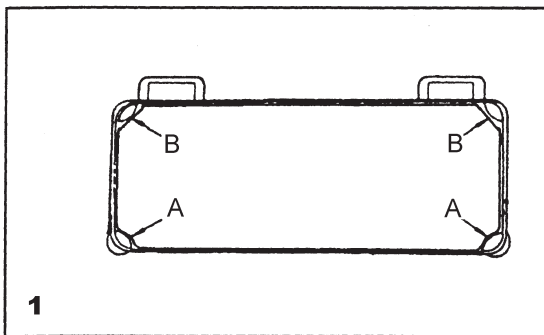

5. Insert Hinges (E) into the opening in the machine bed. See figure 3.
6. Fit the machine head to the table rubber hinges (F) before placing the machine head on the corner seats. See figure 4.

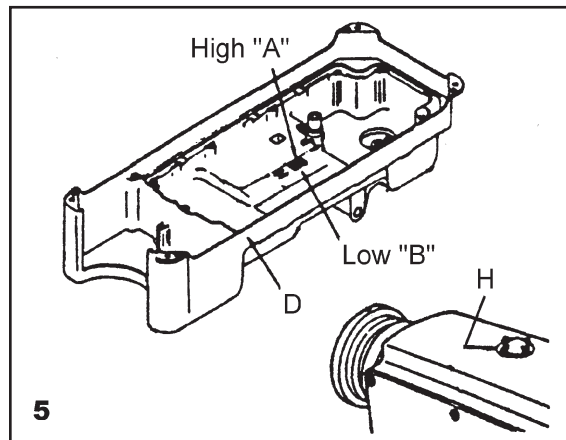

7. Tilt the machine back to expose the Oil Pan (D). See figure 5.
8. Fill the Oil Pan with sewing machine lubrication oil (#7 white oil) to the “high” mark “A”. Add more oil when the level is to the “low” mark “B”. After lubrication, and during operation, oil splashing can be seen through the Oil Sight Window (H).
9. Lower the machine head to the table top.
10. Mount the Motor to the underside of the table top as shown below. Use the supplied hardware.

Note: Top switch determines rotation direction. Switch left for counterclockwise; switch right for clockwise rotation.

Note: Motor is 110/220V Single Phase. Disconnect power and flip switch to desired voltage. Switch left for 110V, switch right for 220V. **For 220 V, the power plug must be rewired by a qualified technician.**

Note: Receptacle for 6 volt work light (not included).



11. Place the V-belt around the Sewing Machine Pulley, through the slot in the table top, and around the Motor pulley. Attach the Pulley Safety Cover.
12. Tighten the V-belt tension by adjusting the long bolt and nut at location (K). The proper tension is reached when the V-belt can only be pushed in 1/2 inch.

13. Mount the Power Switch under the table top, on the operator's side. Use the supplied hardware.

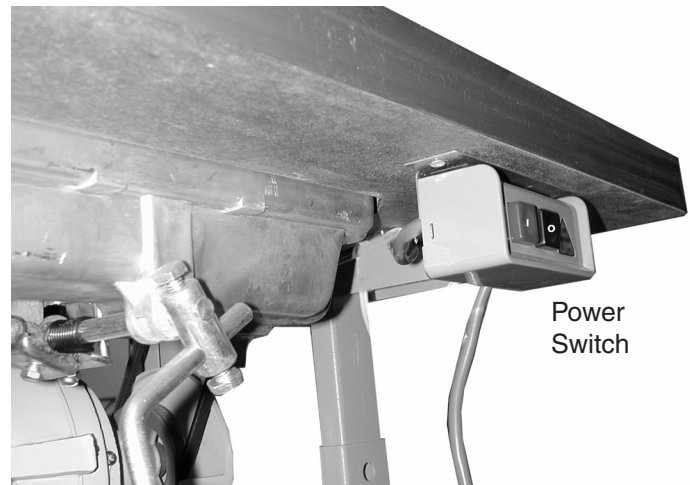

Mounting the Thread Stand

Note: The Thread Stand is designed to be mounted on the Table Stand Kit (Model 03929-not included). Unless indicated otherwise, all parts referred to in this set of instructions are listed in the *Bobbin Winder & Thread Stand Unit Parts List* found on page 28. During assembly, it will be helpful to refer to that list and the diagram that follows it on page 29.

14. Locate the large hole in the far right corner (from the location that the operator will be seated) of the Table (not included). Place the Rubber Washer (45) and Washer (37) onto the Lower Spool Rest Rod (36) and insert the Rod into the hole mentioned above. Place another Washer (37) over the end of the Rod, and thread on and tighten a Nut (38).
15. Place the Spool Support (46) over the Lower Spool Rest Rod (36) about halfway down. Insert a Screw (31) and Nut (47) through the Support.
Note: The Support has tabs that hold onto the corners of the Nut to make tightening easier. When assembling, place the Nut on the side with these tabs.
Tighten the Screw.
16. Insert the threaded end of the Spool Pin (40) through one of the holes in the top of the arm of the Spool Support (46). Place a Washer (32) and Nut (35) over the end of the Pin and tighten. Place the Spool Rest (41), Spool Mat (42), and the Spool Vibration Stopper (39) over the end of the Spool Pin. Repeat this step for both of the Spool Pins (40).
17. Place the Column Pipe Connector (33) over the top of the Lower Spool Rest Rod (36) until the Rod is about halfway through the Connector. Place a Screw (34) and Nut (35) through the bottom hole in the Connector and finger-tighten.
18. Place the Upper Spool Rest Rod (30) into the top of the Column Pipe Connector (33). Place a Screw (34) and Nut (35) through the top hole in the Connector. Tighten all of the Screws and Nuts in the Connector.
19. Place the Thread Hanger (28) about halfway over the top of the Upper Spool Rest Rod (30). Insert a Screw (31) and Nut (47) through the Hanger as explained in the note in step 14, above. Tighten the Screw and place the Column Cap (29) over the end of the Upper Spool Rest Rod (30).

Mounting the Bobbin Winder

Note: Unless indicated otherwise, all parts referred to in this set of instructions are listed in the *Bobbin Winder & Thread Stand Unit Parts List* found on page 28. During assembly, it will be helpful to refer to that list and the diagram that follows it on page 29.

20. Remove the Belt Cover (part 4, on page 27). Swing the sewing machine so the base is in the operating position, resting on the table. Set the Bobbin Winder to the 'ON' Position-see *ON Position*, below.

21. **Make sure the Bobbin Winder is in the 'ON' position.** Position the Base (Bobbin Winder Base Assembly) (1) so that the Thread Winder Assembly (3) lines up with and just touches the belt. Mark pilot hole locations on the table at the far end of each of the two channels in the Base as indicated in *Figure A*.

22. Set the Base (1) aside and swing the sewing machine out of the way. Carefully drill straight pilot holes for each of the two locations marked above. Place the base in location and secure using two Wood Screws (26) and Washers (27). Leave the Screws just loose enough to allow the Base to slide.

23. Swing the Sewing Machine back into its operating position. Put the Bobbin Winder in the 'OFF' position-see *OFF Position*, below. Slide the Bobbin Winder Assembly close to the belt until it just barely doesn't touch it ($\frac{1}{8}$ " gap or less)-see *Figure B*, above. Tighten the Wood Screws (26) from step 22, above.

24. Put the Belt Cover back on the Sewing Machine before use.

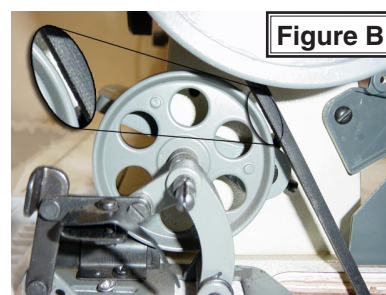

Operation

Caution: To properly break-in your new sewing machine, and avoid possible damage to the machine, sew at moderate to slow speeds for the first 15 minutes of use.

Bobbin Winder Operation

The Bobbin Winder assists in winding thread onto the Bobbin. The Bobbin Winder has two positions, 'ON' and 'OFF':

OFF Position The Bobbin Winder will not contact the belt.

WARNING: Shut the machine off completely before working around the needle or other moving parts.

ON Position This position is with the Connecting Rod (10-6) pressed, as shown in *Figure C*. The Shaft on the Bobbin Winder will spin; winding thread onto the Bobbin.

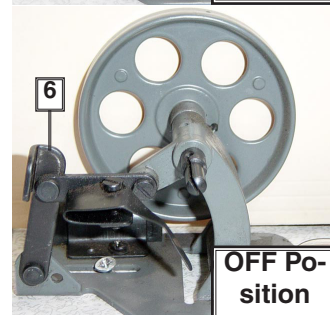
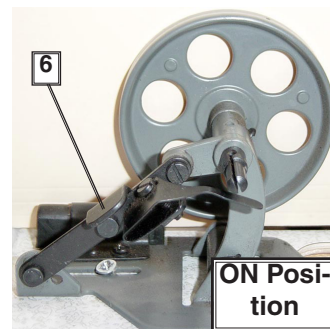

Winding Thread Onto the Bobbin

1. Place a Bobbin onto the Bobbin Winder Shaft (5) as shown at point **d** in *Figure C*, right.
2. Route the Thread from the Spool (not shown) up through the Thread Guide Tube (43, **point a**), the hole in the Thread Tension Bracket Assembly (18, **b**), over and under the far side of the Tension Disc (21, **c**), and connect it to the Bobbin (**d**).-See *Figure D*, right.
3. While the Connecting Rod (6) is pressed (as shown in both *Figures C* and *D*) the Bobbin Winder will be in the 'ON' position and the Bobbin will fill with thread. When finished, release the Connecting Rod and the Bobbin Winder will reset to the 'OFF' position.

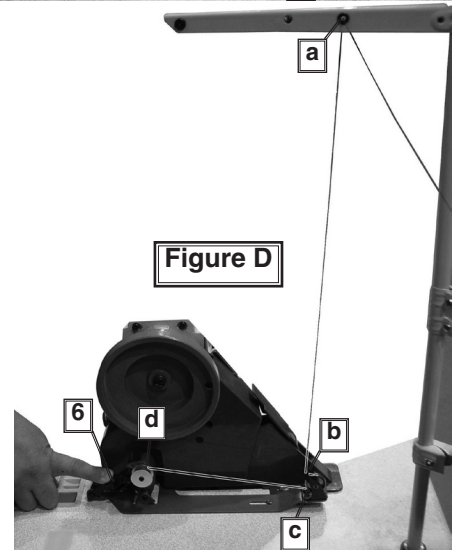
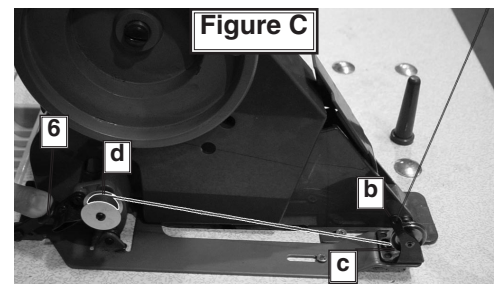

Attaching the Needle

1. Unplug the Power Cord from the electrical outlet.
2. Select a proper needle size according to the thread count and type of material being sewn.
3. Turn the Hand Wheel until the needle bar reaches the highest point of its stroke.
4. Loosen Screw (2) and hold needle (1) with its indented part "A" facing exactly to the right in direction "B".
5. Insert the needle and push it up until it will go no farther.
6. While holding in place, securely tighten Screw (2).

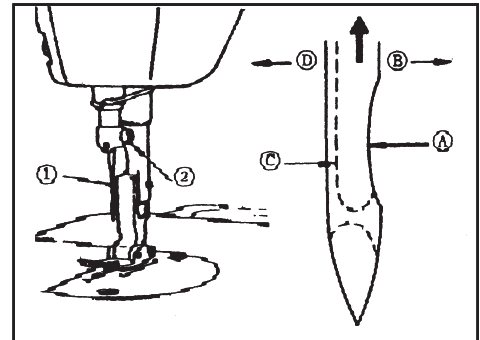

Setting the Bobbin into the Bobbin Case

1. Hold the Bobbin so that the thread exit is to the left, and push the Bobbin into its case.
2. Feed the thread through slit "A" and pull the thread in direction "B". By doing so, the thread will pass under the tension spring and exit at notch "B".
3. Verify that the Bobbin rotates in the direction of the arrow when thread "C" is pulled.

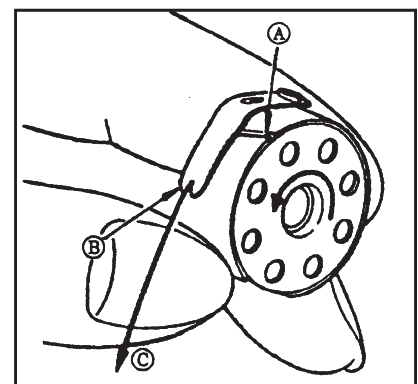

Threading the Machine Head

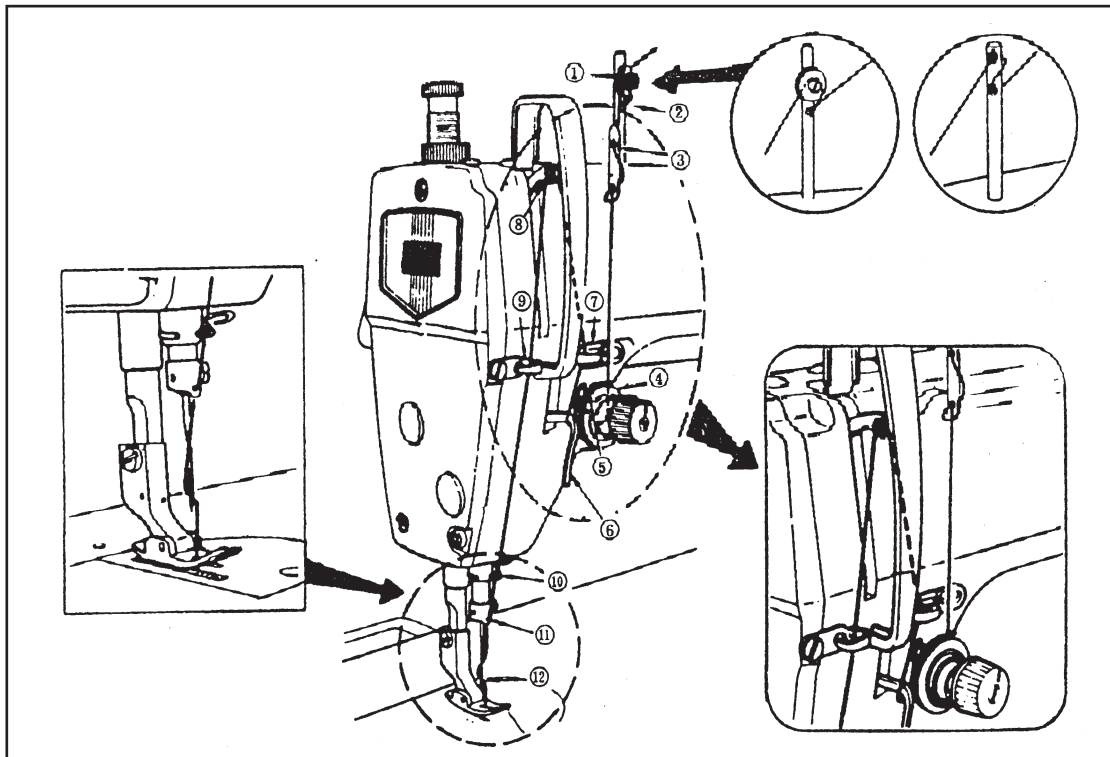

Set the thread spool on its holder and guide the thread through the machine as illustrated above. The numbers in the illustration indicate the threading sequence.

Adjusting the Stitch Length

1. To increase the stitch length, turn the Stitch Length Dial (1) to the desired number (in millimeters) as indicated under the scale dot (A) on the machine.
2. To decrease the stitch length, turn the Stitch Length Dial (1), while pressing the Feed Lever (2).

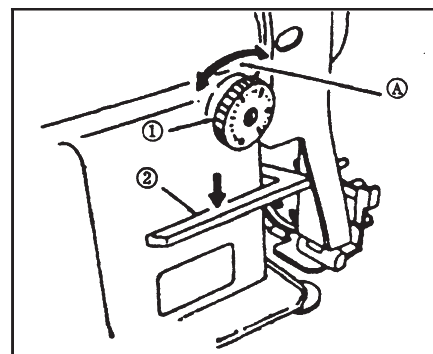

Adjusting the Needle Thread Tension

1. Turn Tension Adjustment Knob (1) clockwise (A) to increase thread tension.
2. Turn Tension Adjustment Knob (1) counterclockwise (B) to decrease thread tension.

Adjusting the Bobbin Thread Tension

1. Turn the Tension Adjustment Screw (2) clockwise (A) to increase bobbin tension.
2. Turn the Tension Adjustment screw (2) counterclockwise (B) to decrease bobbin tension.

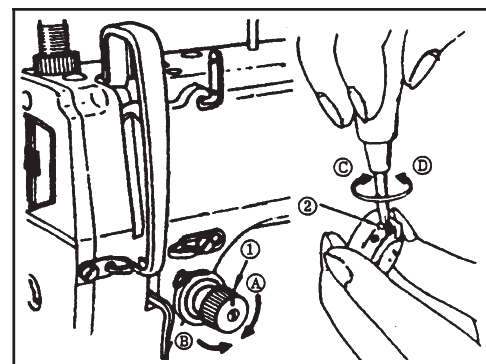

Changing the Thread Take-up Spring Stroke and Pressure

1. Loosen Set Screw (2).
2. To increase the stroke, turn the Tension Knob Screw (3) clockwise (A).
3. To decrease the stroke, turn the Tension Knob Screw (3) counterclockwise (B).
4. Loosen Set Screw (2) and pull out the Tension Arm (5).
5. Loosen Set Screw (4) and remove the Tension Knob Screw (3).
6. Turn the Tension Knob Screw (3) clockwise (A) to increase pressure; or turn counterclockwise (B) to decrease pressure.
7. Replace Tension Knob Screw (3), tighten Set Screw (4), and replace the assembly.

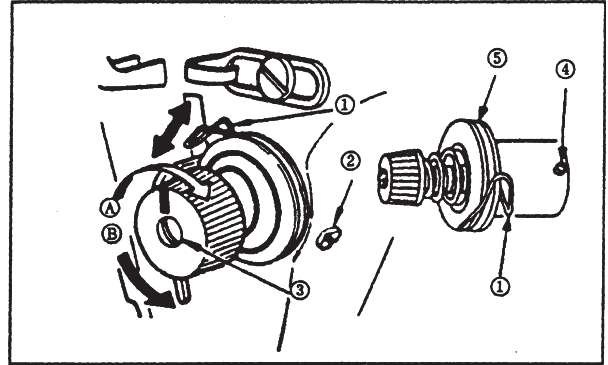

Setting the Hand Lifter

1. To stop the machine with its Presser Foot up, turn the Hand Lifter (1) up (A).
The Presser Foot will go up about 1/4 inch and stop.
2. To set the Presser Foot to its original position, turn the Hand Lifter (1) down (B).

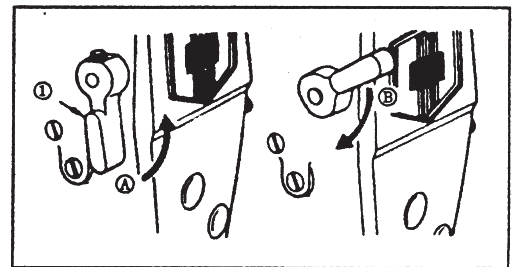

Using the Knee Lifter, you can get the standard Presser Foot lift of about 1/2 inch.

Setting the Presser Foot Pressure

1. Loosen Nut (2), and turn the Presser Spring Regulator (1) clockwise (A) to increase Presser Foot pressure.
2. To decrease Presser Foot pressure, turn the Presser Spring Regulator (1) counterclockwise.
3. After adjustment, tighten Nut (2).

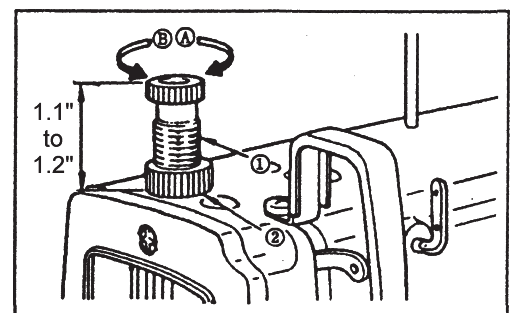

Adjusting the Feed Timing

1. Loosen Set Screws (2) and (3) on the Feed Eccentric Cam (1) and properly position the Eccentric Cam. Retighten the Set Screws.
2. To advance the feed timing in order to prevent uneven material feed, move the Feed Eccentric Cam up (clockwise).
3. To delay the feed timing in order to increase stitch

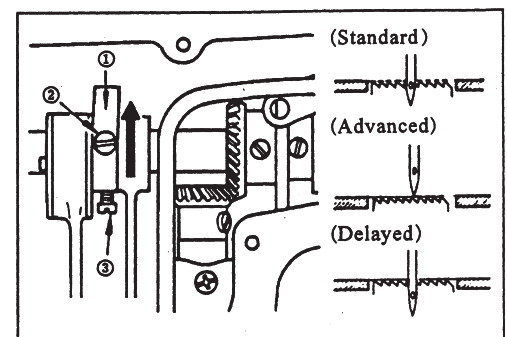

tightness, move the Feed Eccentric Cam down (counterclockwise).

Adjusting the Height of the Feed Dog

The Feed Dog is factory adjusted so that it juts out from the Throat Plate surface 0.8 mm to 0.9 mm. If the Feed Dog juts out too much, puckering may result when sewing lightweight materials. To adjust the height of the Feed Dog:

1. Loosen Screw (2) of Crank (1).
2. Move the Feed Bar up or down to make the adjustment.
3. Tighten Screw (2), being careful not to overtighten.

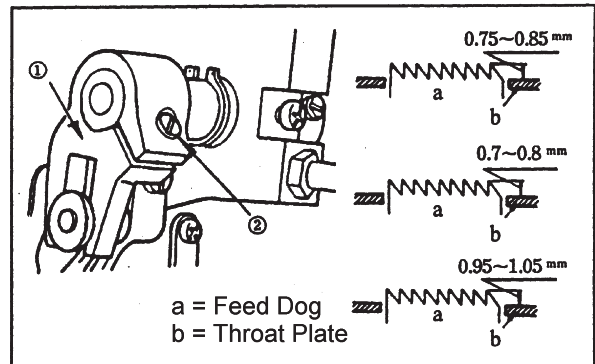

Adjusting Needle-to-hook Timing

1. Turn the Hand Wheel to bring the needle bar down to the lowest point of its stroke.
2. Loosen Set Screw (1).
3. When using a DBX1 needle, align to marker line "A" on the needle bar (2) with the bottom end of the needle bar lower bushing (3), then tighten Set Screw (1).

When using a DAX1 needle, align to marker line "B" on the needle bar (2) with the bottom end of the needle bar lower bushing (3), then tighten Set Screw (1).

4. When using a DBX1 needle, loosen three Hook Set Screws, turn the Hand Wheel, and align the marker line "B" on the needle bar (2) with the bottom end of the needle bar lower bushing (3).

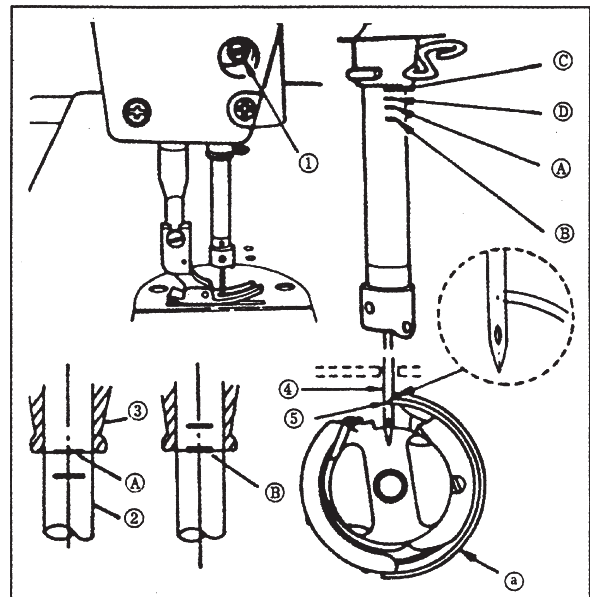

When using a DAX1 needle, align the marker line "D" on the needle bar (2) with the bottom end of the needle bar lower bushing (3).

5. After making the adjustments in steps 3 and 4, align the Hook Blade point (5) with the center of the needle (4).

Provide a clearance of .001" to .004" (0.04 to 0.1 mm) between the needle and the hook. This clearance is less than 1/64" (almost touching). Securely tighten the three Set Screws. If the clearance is too small, the tip of the hook will be abraded. If it is too large, it will lead to skip over.

Adjusting the Presser Bar Height

1. Loosen Set Screw (1) and manually adjust the Presser Bar height, and the angle of the Presser Foot.
2. After adjusting, securely tighten the Set Screw (1).

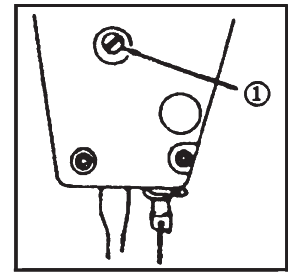

Adjusting the Thread Take-up Stroke

1. When sewing heavy weight materials, move the Thread Guide (1) to the left (A) to increase the length of thread pulled out by the Thread Take-up.
2. When sewing lightweight materials, move the Thread Guide (1) to the right (B) to decrease the length of thread pulled out by the Thread Take-up.
3. The normal setting is when the marker line "C" on the Thread Guide (1) is aligned with the center of the screw.

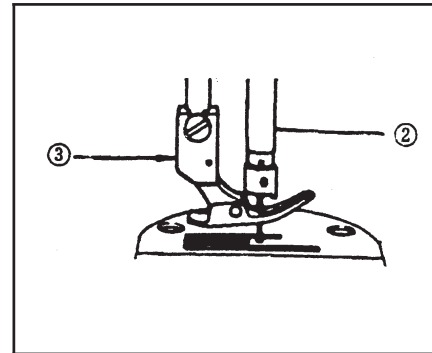
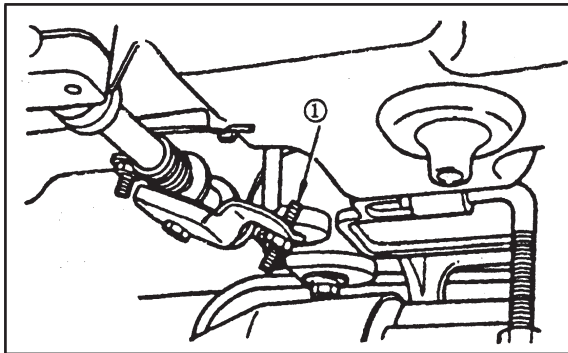
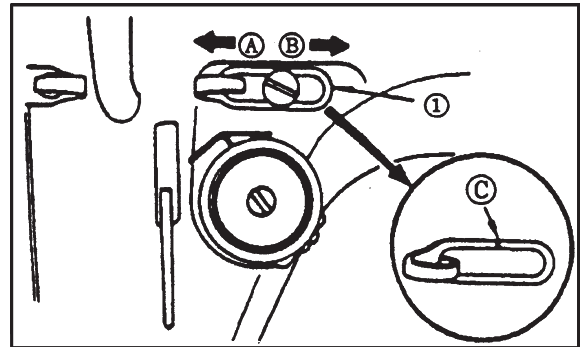

Adjusting the Height of the Knee Lifter

The standard height of the Presser Foot lifted using the Knee Lifter is 0.39 inch (10 mm).

1. To adjust the Presser Foot lift up to 0.5 inch (13 mm), adjust the Screw (1).
2. When the Presser Foot lift is adjusted over 0.39 inch (10 mm), be sure that the bottom end of the Needle Bar (2) does not hit the Presser Foot (3).

This can be manually checked by turning the Hand Wheel.

Maintenance

1. Machine adjustments should only be performed by a qualified technician.
2. Check the oil level weekly when the machine is used daily. Add sewing machine oil as required to the high level marking.
3. Clean the machine with a clean, damp cloth. Do not use solvents or thinners.
4. When not in use, cover the machine and store in a clean and dry location.

ARM BED PARTS LIST

Ref. No.	Part No.	Description	Amt. Req.
1	01.01.1-0 Arm bed assembly	1
2	01.01.2-0(229-45356) Tension Complete subassembly	
3	01.01.2-1(229-21308) Thread tension nut	1
4	01.01.2-2(229-21407) Thread disc rotation stopper	1
5	01.01.2-3(229-21704) Thread tension spring	1
6	01.01.2-4(229-21803) Thread release disc	1
7	01.01.2-5(229-21506) Thread tension disc	2
8	01.01.2-6(229-21209) Tension screw	1
9	01.01.2-7(229-21605) Take-up spring	1
10	01.01.2-8(229-45307) Thread tension post socket	1
11	01.01.2-9(SS-8090670-SP) Set screw	1
12	01.01.3(B3188-552-E00) Tension release pin	1
13	01.01.4-0(229-00757) Oil packing subassembly	1
14	01.01.4-1 Oil packing cover	1
15	01.01.4-2 Oil wick	1
16	01.01.5(SS-6080410-SP) Screw	1
17	01.01.6(229-00609) Thread take-up lever cover	1
18	01.01.7(SS-4120615-SP) Thread take-up lever cover screw	1
19	01.01.8(229-00401) Face plate asm	1
20	01.01.9(SS-4120915-SP) Screw	8
21	01.01.10(110-00619) Gasket	1
22	01.01.11(TA-2000502-R0) Rubber plug	1
23	01.01.12(TA-2101002-R0) Rubber plug	1
24	01.01.13(SS-8150710-SP) Thread tension screw	1
25	01.01.14-0(229-32552) Face plate thread retaining guide subassembly	
26	01.01.14-1(229-32503) Face plate thread guide retaining	1
27	01.01.14-2(229-32602) Thread tension disc	2
28	01.01.14-3(229-32701) Thread tension spring	1
29	01.01.14-4(SD-0380552-SL) Thread tension screw	1
30	01.01.15(TA-1250705-R0) Rubber plug needle drining crank hole	1
31	01.01.16(229-20706) Three hole thread eyecket	1
32	01.01.17(229-02159) Face plate	1
33	01.01.18(229-02209) Face plate sealing gasket	1
34	01.01.19(229-20607) Face plate thread guide	1
35	01.01.20(229-20508) Thread guide right	1
36	01.01.21(110-01500) Thread guide screw	2
37	01.01.22(TA-1250406-R0) Rubber plug	2
38	01.01.23-0(229-01250) Bed slide subassembly	
39	01.01.23-1(229-01201) Slide plate	1
40	01.01.23-2(229-01300) Slide plate spring	1
41	01.01.23-3(SS-6060210-SP) Slide plate spring screw	2
42	01.01.24(110-28008) Throat plate	1
43	01.01.25(SS-2110920-TP) Throat plate screw	2
44	01.01.26(229-01003) Bed screw stud	4
45	01.01.27(TA-0850604-R0) Rubber plug thread take-up lever link pin hole	2
46	01.01.28	1
47	01.01.29 Brand plate	1
48	 Brand plate rivet	2
49	01.01.30(110-04109) Main shaft bushing	1
50	01.01.31(229-02605) Connecting rod	1
51	01.01.32(SS-7110540-SP) Screw	2

ARM BED ASSEMBLY DRAWING

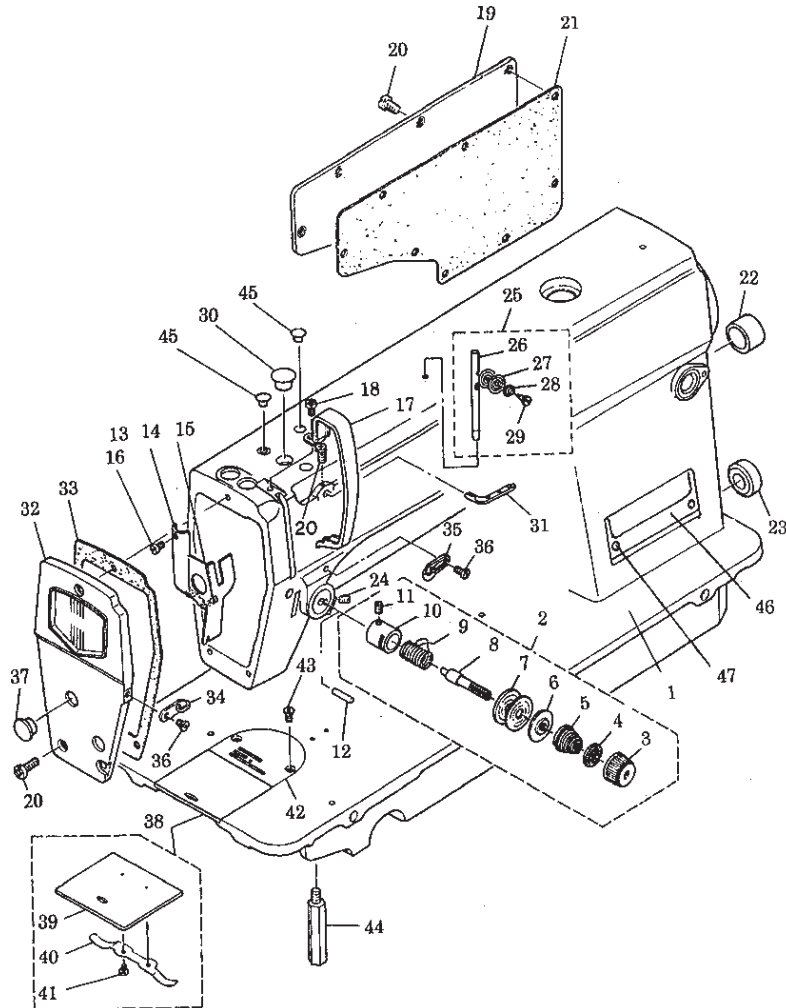

NOTE: When ordering parts from the following lists, always include the list title, item number and description, and page number. For example, to order the first part from page 14 list, you would state:

- Arm Bed Parts List
- Item #1 - Arm Bed Assembly
- Page: 14

NOTE: Some parts are listed and shown for illustration purposes only and are not available individually as replacement parts.

PLEASE READ THE FOLLOWING CAREFULLY

THE MANUFACTURER AND/OR DISTRIBUTOR HAS PROVIDED THE PARTS DIAGRAM IN THIS MANUAL AS A REFERENCE TOOL ONLY. NEITHER THE MANUFACTURER NOR DISTRIBUTOR MAKES ANY REPRESENTATION OR WARRANTY OF ANY KIND TO THE BUYER THAT HE OR SHE IS QUALIFIED TO MAKE ANY REPAIRS TO THE PRODUCT OR THAT HE OR SHE IS QUALIFIED TO REPLACE ANY PARTS OF THE PRODUCT. IN FACT, THE MANUFACTURER AND/OR DISTRIBUTOR EXPRESSLY STATES THAT ALL REPAIRS AND PARTS REPLACEMENTS SHOULD BE UNDERTAKEN BY CERTIFIED AND LICENSED TECHNICIANS AND NOT BY THE BUYER. THE BUYER ASSUMES ALL RISK AND LIABILITY ARISING OUT OF HIS OR HER REPAIRS TO THE ORIGINAL PRODUCT OR REPLACEMENT PARTS THERETO, OR ARISING OUT OF HIS OR HER INSTALLATION OF REPLACEMENT PARTS THERETO.

MAIN SHAFT THREAD TAKE-UP PARTS LIST

Ref. No.	Part No.	Description	Amt. Req.
1	01.02.1-0(110-39070)	Thread take-up subassembly	1
2	01.02.2(229-03108)	Needle bar crank	1
3	01.02.3(SS-8681650-TP)	Set screw	1
4	01.02.4(SS-7681650-TP)	Screw	1
5	01.02.5(RO-0442401-00)	O-Rubber ring	1
6	01.02.6(110-39062)	Thread take-up lever link	1
7	01.02.7(229-27206)	Hand wheel	1
8	01.02.8(SS-8151550-SP)	Screw, hand wheel	2
9	01.02.9(229-03504)	Sealing ring	1
10	01.02.10(229-03405)	Main shaft rear bushing subassembly	1
11	01.02.11(229-10103)	Plate	1
12	01.02.12(229-10004)	Feed drive eccentric cam	1
13	01.02.13(RC-1850001-KP)	Snap ring	1
14	01.02.14(SS-6661110-SP)	Screw	2
15	01.02.15(SS-8660610-TP)	Snap ring screw	2
16	01.02.16(229-04155)	Main shaft thrust collar	1
17	01.02.17(229-03306)	Main shaft middle bushing	1
18	01.02.18(SS-8151150-SP)	Screw	1
19	01.02.19(229-19559)	Thread take-up lever link pin	1
20	01.02.20(CQ-3500000-F0)	Oil wick	1
21	01.02.21(B1903-552-000)	End screw, left-hand	1
22	01.02.22-0(110-05204)	Thread take-up crank subassembly	1
23	01.02.23(B1408-552-000)	Needle bar crank connecting rod	1
24	01.02.24(B1905-541-B00)	Needle bearing	2
25	01.02.25(B1212-552-000)	Needle bar crank wearing plate	1
26	01.02.26-0	Crank oil adjusting subassembly	1
27	01.02.26-1(229-03900)	Crank oil adjusting pin	1
28	01.02.26-2(229-04007)	Rubber bushing	1
29	01.02.26-3(RO-0291801-00)	O-Rubber ring	1
30	01.02.27(229-03702)	Main shaft felt	1
31	01.02.28(229-03207)	Main shaft front bushing subassembly	1
32	01.02.29(229-03009)	main shaft	1
33	01.02.30(SS-6090650-SP)	Screw	2
34	01.02.31	Screw	1

MAIN SHAFT THREAD TAKE-UP ASSEMBLY DRAWING

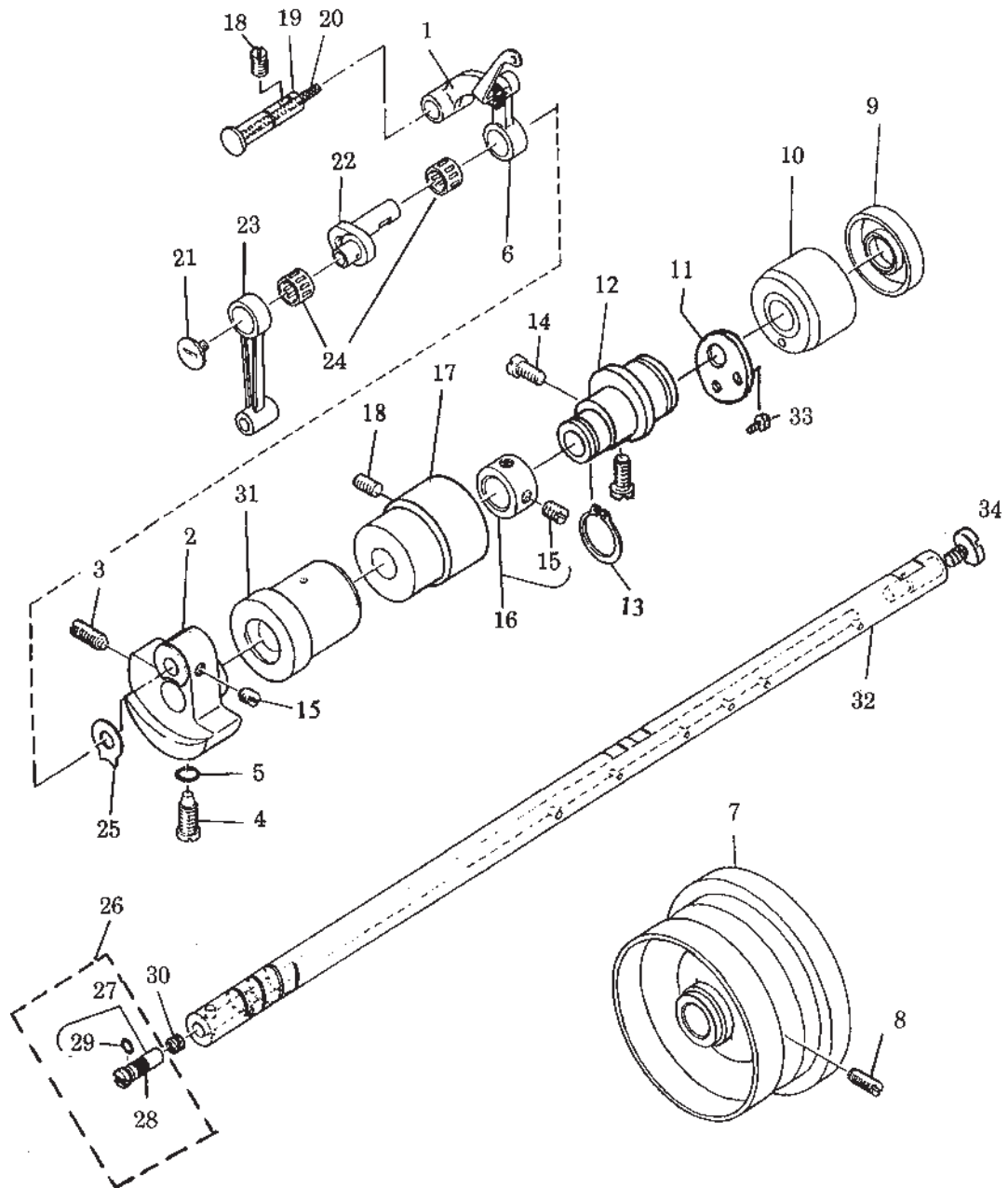

FABRIC--PIERCING HOOK DRIVING PARTS LIST

Ref. No.	Part No.	Description	Amt. Req.
1	01.03.1(SS-4110915-SP)	• Screw	1
2	01.03.2(229-16407)	• Rotating hoot positioning finger	1
3	01.03.3(229-05202)	• Upright shaft lower bushing	1
4	01.03.4(SS-8660810-TP)	• Set screw	8
5	01.03.5(B1307-155-0A0)	• Bevel gear	1
6	01.03.6(229-05004)	• Upright shaft	1
7	01.03.7(B1308-155-0A0)	• Bevel pinion	1
8	01.03.8(SS-4120915-SP)	• Screw	2
9	01.03.9(229-16308)	• Hook driving shaft rear bushing	1
10	01.03.10(SS-6110420-TP)	• Screw	2
11	01.03.11(229-17157)	• Hook driving shaft thrust collar	1
12	01.03.12(229-16001)	• Hook driving shaft	1
13	01.03.13-0(229-16100)	• Hook driving shaft front bushing subassembly	1
14	01.03.14(SS-8150432-TH)	• Set screw	1
15	01.03.15(SS-8110410-TP)	• Screw	2
16	01.03.16(229-17058)	• Hook driving shaft front thrust collar	1
17	01.03.17(229-16605)	• Oil wick	1
18	01.03.18(229-16506)	• Hook driving shaft front screw	1
19	01.03.33-0	• Rotating hook subassembly	
20	01.03.34(B1830-127-0A0)	• Rotating hook	1
21	01.03.35(B1837-012-0A0)	• Bobbin case	1
22	01.03.36(229-32909)	• Bobbin	1
23	01.03.19(MDB-100B1400)	• Needle	1
24	01.03.20(229-06309)	• Needle bar thread guide	1
25	01.03.21(SS-7080510-TP)	• Screw	1
26	01.03.22(229-20805)	• Needle bar lower bushing thread guide	1
27	01.03.23(229-06200)	• Needle bar lower bushing	1
28	01.03.24(SS-6090670-TP)	• Screw	1
29	01.03.25(229-06457)	• Needle bar connecting pin	1
30	01.03.26(229-06507)	• Needle bar guide block	1
31	01.03.27(229-06002)	• Needle bar	1
32	01.03.28(229-06101)	• Needle bar upper bushing	1
33	01.03.29(229-01409)	• Rubber plug	1
34	01.03.30(B1305-012-0A0)	• Bevel gear	1
35	01.03.31(B1306-155-0A0)	• Bevel pinion	1
36	01.03.32(229-05103)	• Upright shaft upper bushing	1

FABRIC--PIERCING HOOK DRIVING ASSEMBLY DRAWING

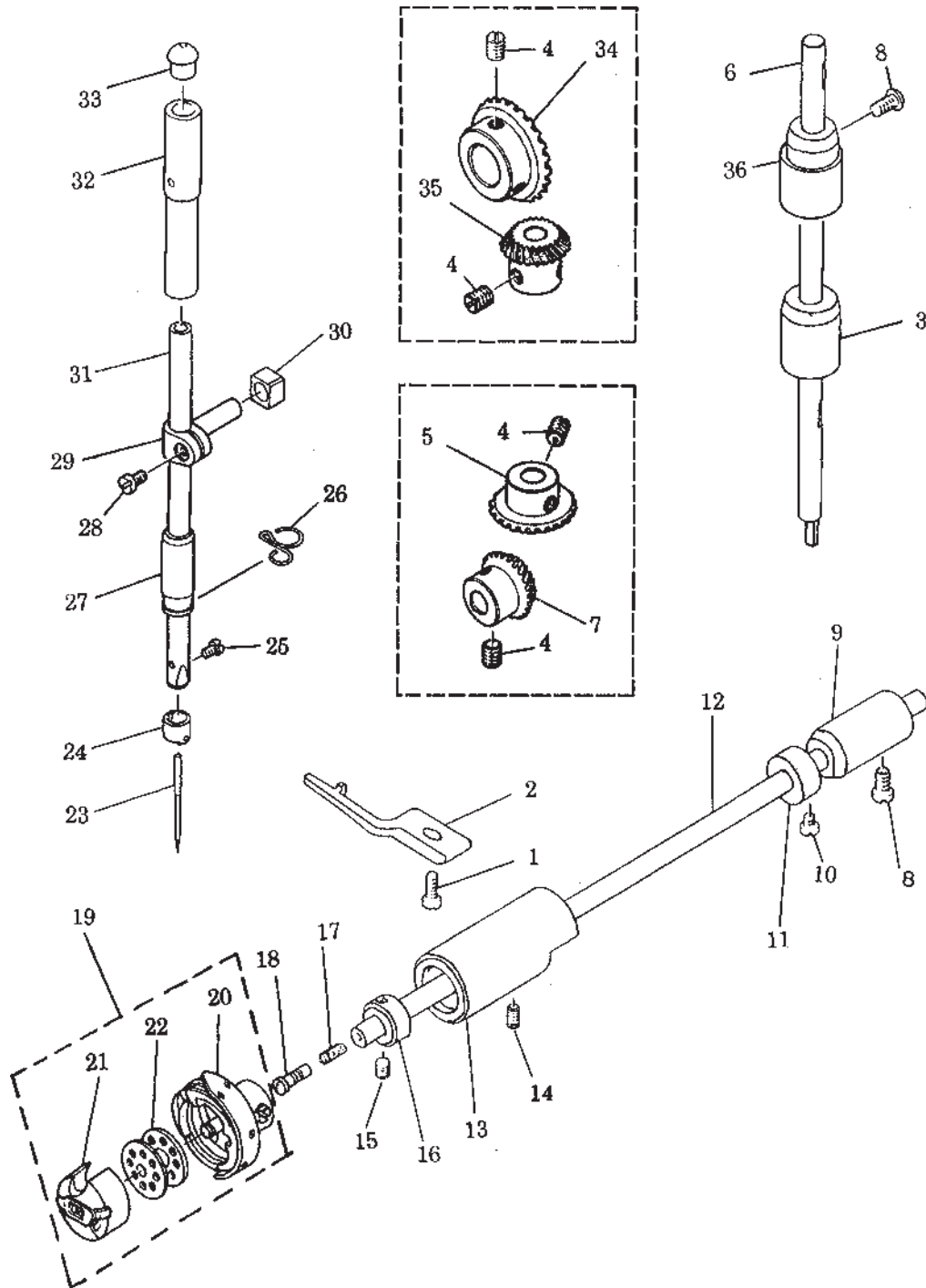

PRESSER BAR PARTS LIST

Ref. No.	Part No.	Description	Amt. Req.
1	01.04.1(SD-0720332-SP)	Hinge screw	1
2	01.04.2(110-07101)	Screw	1
3	01.04.3(110-18405)	Spring	1
4	01.04.4(110-19007)	Washer	1
5	01.04.5	Washer	1
6	01.04.6(B1521-555-000)	Screw	1
7	01.04.7(RE-0400000-R0)	Snap ring	1
8	01.04.8(110-18306)	Pin	1
9	01.04.9-0(B1524-012-0B0)	Hinged presser foot subassembly	1
10	01.04.10(SS-7091110-SP)	Screw	1
11	01.04.11(B1501-127-000)	Presser bar	1
12	01.04.12(B1502-541-000)	Presser bar bushing	1
13	01.04.13(110-06004)	Presser bar guide braket	1
14	01.04.14(110-06202)	Lifting hook	1
15	01.04.15(RE-0500000-R0)	Spring	6
16	01.04.16-0(110-06350)	Connecting rod subassembly	1
17	01.04.17-0(110-06756)	Hand lifer cam subassembly	1
18	01.04.18(B1520-552-000-A)	Hand lifer lever	1
19	01.04.19(B1511-555-000)	Presser spring regulator nut	1
20	01.04.20(B1509-555-000)	Presser spring regulator	1
21	01.04.21(110-18009)	Tension release lever	1
22	01.04.22(110-06905)	Lifting lever presser rod	1
23	01.04.23(110-07002)	Lifting lever rear crank	1
24	01.04.24(110-07200)	Lifting lever presser rod	1
25	01.04.25(B1510-227-000)	Pressure lever	1
26	01.04.26(RO-0371801-00)	Lifting lever crank shaft screw	1
27	01.04.27(B1505-227-000-A)	Presser spring	1
28	01.04.28(110-06509)	Lifting lever shaft hinger screw	2
29	01.04.29(110-18207)	Spring	1
30	01.04.30(110-18108)	Hinger screw	1
31	01.04.31(110-06103)	Thread release finger	1
32	01.03.4(SS-8660810-TP)	Presser bar guide screw	1
33	01.04.32(SS-7090910-SP)	Screw	2

PRESSER BAR ASSEMBLY DRAWING

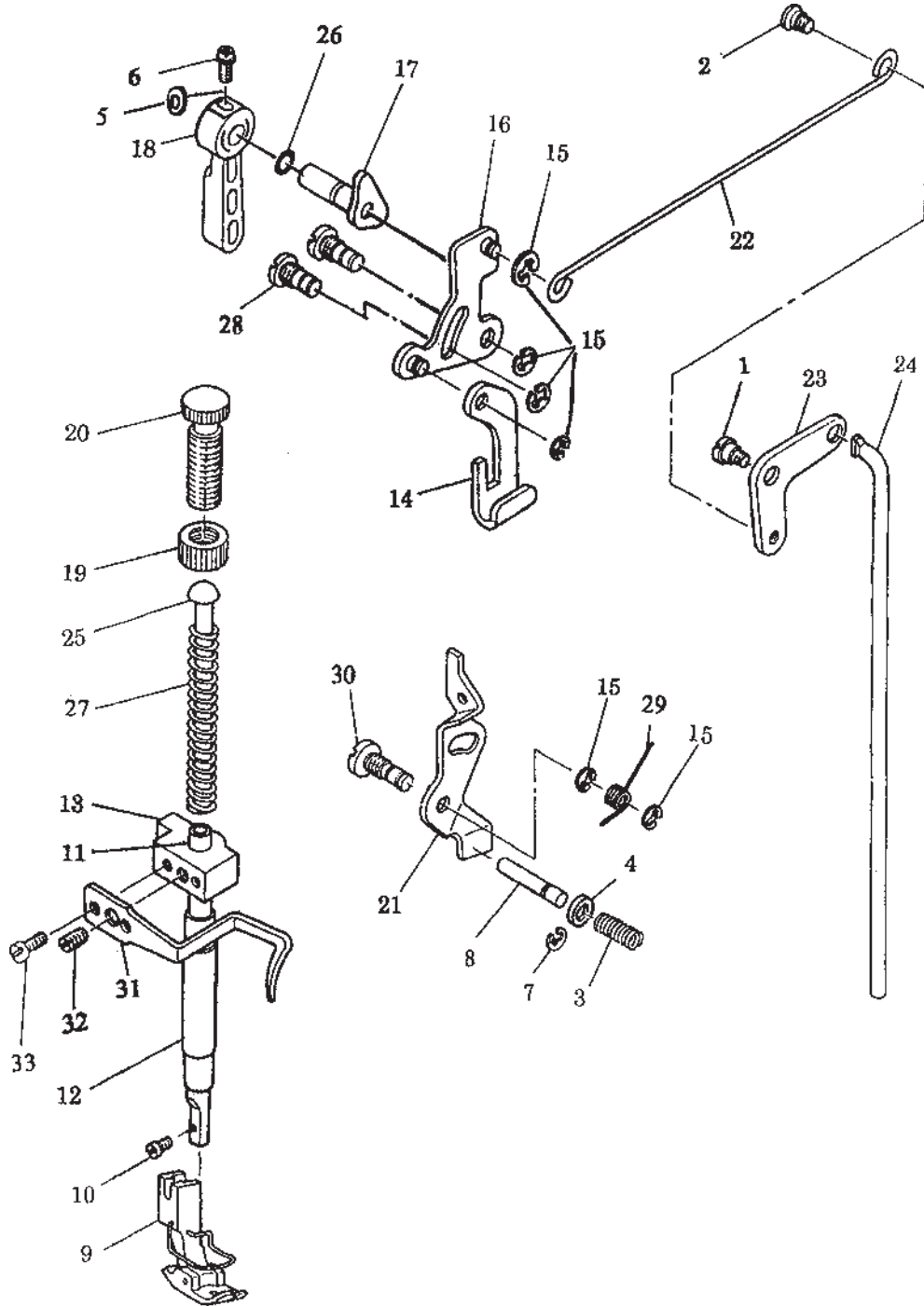

FEED MECHANISM PARTS LIST

Ref. No.	Part No.	Description	Amt. Req.
1	01.05.1(110-14354)	Feed lifting shaft crank	1
2	01.05.2(SS-7111120-SP)	Clamp screw	1
3	01.05.3(SS-4080620-TP)	Feed dog screw	2
4	01.05.4-0(110-11251)	Feed bar body subassembly	1
5	01.05.5(B1613-012-A00)	Feed dog	1
6	01.05.6(RC-1381001-KP)	Snap ring	2
7	01.05.7(110-10907)	Feed rocker shaft and feed driving shaft bushing	2
8	01.05.8(CS-147121A-SH)	Thrust collar	2
9	01.05.9(SS-8660610-TP)	Screw	4
10	01.05.10(110-14206)	Feed driving shaft	1
11	01.05.11(110-10808)	Feed rocker shaft	1
12	01.05.12(SS-6121210-SP)	Feed driving shaft crank damp screw	1
13	01.05.13(110-14156)	Feed driving shaft crank	1
14	01.05.14(SS-8150710-SP)	Screw	2
15	01.05.15-0(110-08455)	Feed driving rocker slate subassembly	1
16	01.05.16(110-08604)	Shorter feed driving rocker slate	2
17	01.05.17(110-09206)	Feed rocking shaft connecting rod pin	1
18	01.05.18(110-08703)	Longer feed driving rocker slate	2
19	01.05.19(110-09107)	Feed rocker crank pin	1
20	01.05.20(110-09008)	Shorter feed driving rocker slate connecting pin	2
21	01.05.21(110-08802)	Feed driving rocker slate pin, right	1
22	01.05.22(110-10600)	Reverse feed control lever	1
23	01.05.23(SS-8660810-TP)	Screw	2
24	01.05.24(110-11053)	Feed rocker	1
25	01.05.25(CQ-2520000-00)	Oil wick	1
26	01.05.26(SS-7110740-TP)	Screw	1
27	01.05.27(SS-7121410-SP)	Screw	1
28	01.05.28	Washer	1
29	01.05.29(SS-7121410-SP)	Feed crank screw	2
30	01.05.30(110-08356)	Feed crank	1
31	01.05.31(110-11301)	Guide	1
32	01.05.32(110-09404)	Spring	1
33	01.05.33(SS-7110510-SP)	Screw	2
34	01.05.34(110-08208)	Feed rocking shaft connecting rod	1
35	01.05.35(110-09305)	Feed driving rocker slate return board	1
36	01.05.36(110-10402)	Feed reverse lever hinge screw	1
37	01.05.37-0(110-10154)	Feed reverse crank subassembly	1
38	01.05.38(110-09503)	Feed reverse connecting rod	1
39	01.05.39(110-09701)	Feed regulator	1
40	01.05.40(110-09909)	Feed regulator stud	1
41	01.05.41(110-14008)	Feed lifting connecting rod	1
42	01.05.42(RO-0922702-00)	O-ring	1
43	01.05.43(SS-6120930-TP)	Feed regulator knob screw	1
44	01.05.44(B1148-555-000)	Lock pin spring	1
45	01.05.45(110-52701)	Lock pin	1
46	01.05.46(110-10006)	Feed regulator knob	1
47	01.05.47(SS-6090620-TP)	Feed rocking shaft connecting rod screw	4
48	01.05.48(SS-6090620-SP)	Screw	4
49	01.05.49(SS-8661040-TP)	Feed reverse lever clamping screw	1
50	01.05.50(110-10501)	Feed reverse shaft	1
51	01.05.51(RO-0781901-00)	Feed reverse shaft O-ring	1
52	01.05.52(110-10303)	Feed reversing spring	1
53	01.05.53(110-10709)	Feed reversing shaft bushing	1
54	01.05.54(SS-7120770-SH)	Feed regulating spindle screw	1
55	01.05.55(NS-6680410-SP)	Feed lifting nut	1
56	01.05.56(110-09800)	Feed regulator bushing	1
57	01.05.57(110-09602)	Feed reverse connecting rod pin	1
58	01.05.58(RE-0500000-K0)	Snap ring	2
59	01.05.59(SD-1000801-SH)	Feed lifting rock screw	1
60	01.05.60(110-08901)	Feed driving rocker slate pin, left	1
61	01.05.61(SS-8150432-TH)	Feed rocker shaft, bushing screw	1
62	01.02.62(SS-4120915-SP)	Feed lifting shaft, bushing screw	1
63	01.05.63(110-11103)	Feed holder shaft	1

FEED MECHANISM ASSEMBLY DRAWING

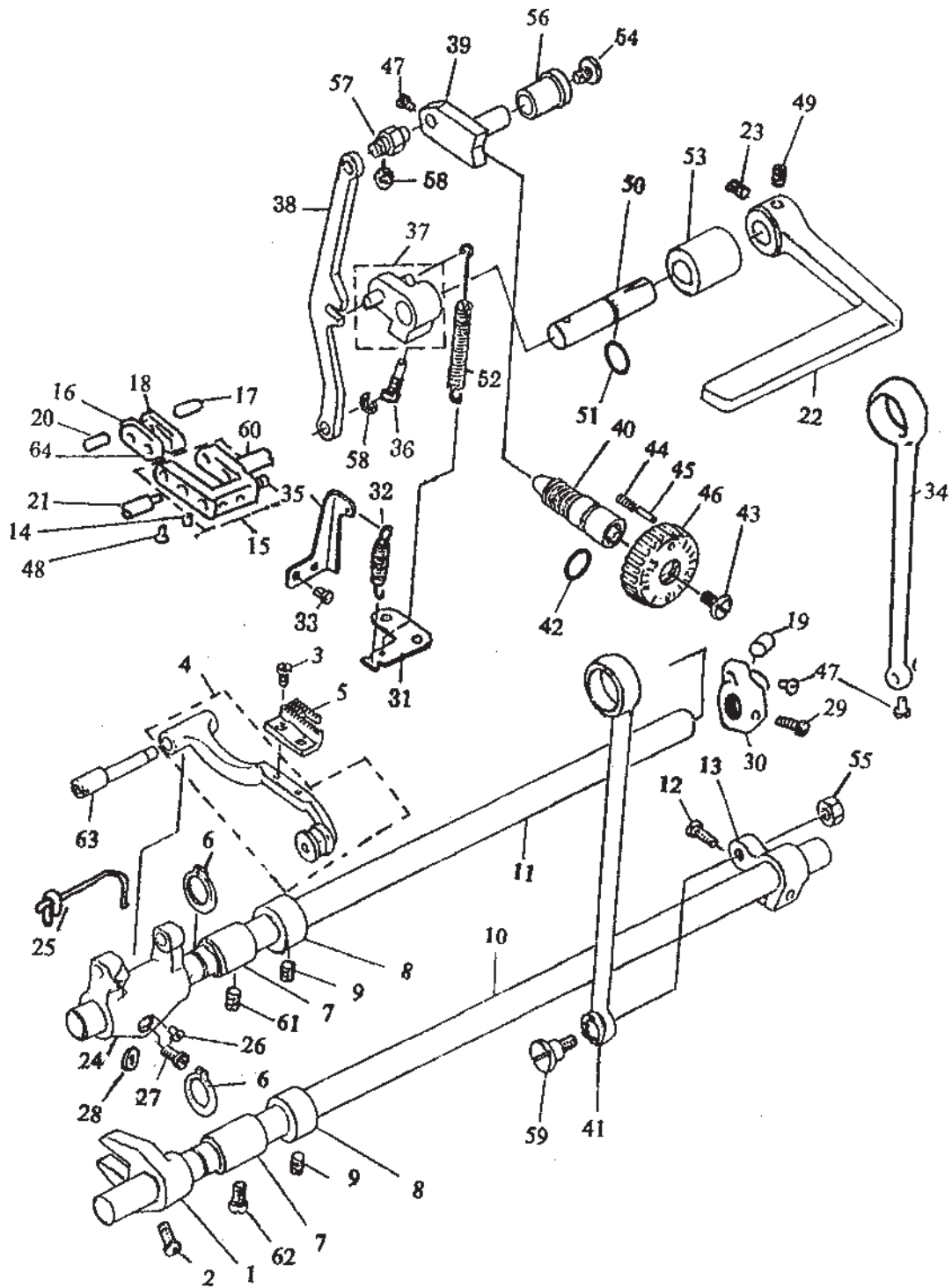

LUBRICATION PARTS LIST

Ref. No.	Part No.	Description	Amt. Req.
1	01.06.1(B3530-555-000)	Oil sight window	1
2	01.06.2(110-21201)	Main shaft oil tube	1
3	01.06.3(110-21151)	Oil return tube holdetr	1
4	01.06.4(110-21003)	Oil pump installing base	1
5	01.06.5-0(110-20054)	Lubrication oil pump subassembly	1
6	01.06.5-1	Oil pump sreen	1
7	01.06.5-2	Oil pump body bushing	1
8	01.06.5-3(110-20708)	Oil pump impeller	1
9	01.06.5-4(110-20005)	Lubrication oil pump	1
10	01.06.5-5(110-20401)	Oil return pump pluger	1
11	01.06.5-6(110-20500)	Oil adjusting screw	1
12	01.06.5-7(110-20609)	Spring	1
13	01.06.5-8(110-20807)	Oil pump impeller cover	1
14	01.06.5-9(110-20203)	Lubricating oil pump cover	1
15	GB818-76(SL-4030851-SR)	Screw	3
16	GB862-76	Washer	3
17	GB845-76(SE-4301041-SR)	Screw	3
18	01.06.6(SS-6111010-SP)	Screw	1
19	01.06.7(110-21409)	Oil pump three way	1
20	01.06.8(110-20906)	Rubber joint	1
21	01.06.9(110-20302)	Oil pump holder	1
22	01.06.10(SS-4150915-SP)	Screw	2
23	01.06.11(110-21706)	Oil pump impeller cover	1
24	01.06.12(110-21300)	Oil tube	1
25	01.06.13(B3514-412-000)	Oil adjusting screw	1
26	01.06.14(B2616-372-000)	Spring	1
27	01.06.15(B3529-226-000)	Oil return tube holder	1
28	01.06.16	Oil return tube plate	1
29	01.06.17(110-21805)	Oil return tube holder	1
30	01.06.18(SS-4120615-SP)	Screw	2
31	01.06.19(110-21607)	Oil return clamp	1
32	GB1235-76(RO-1952401-00)	O-ring	1

LUBRICATION ASSEMBLY DRAWING

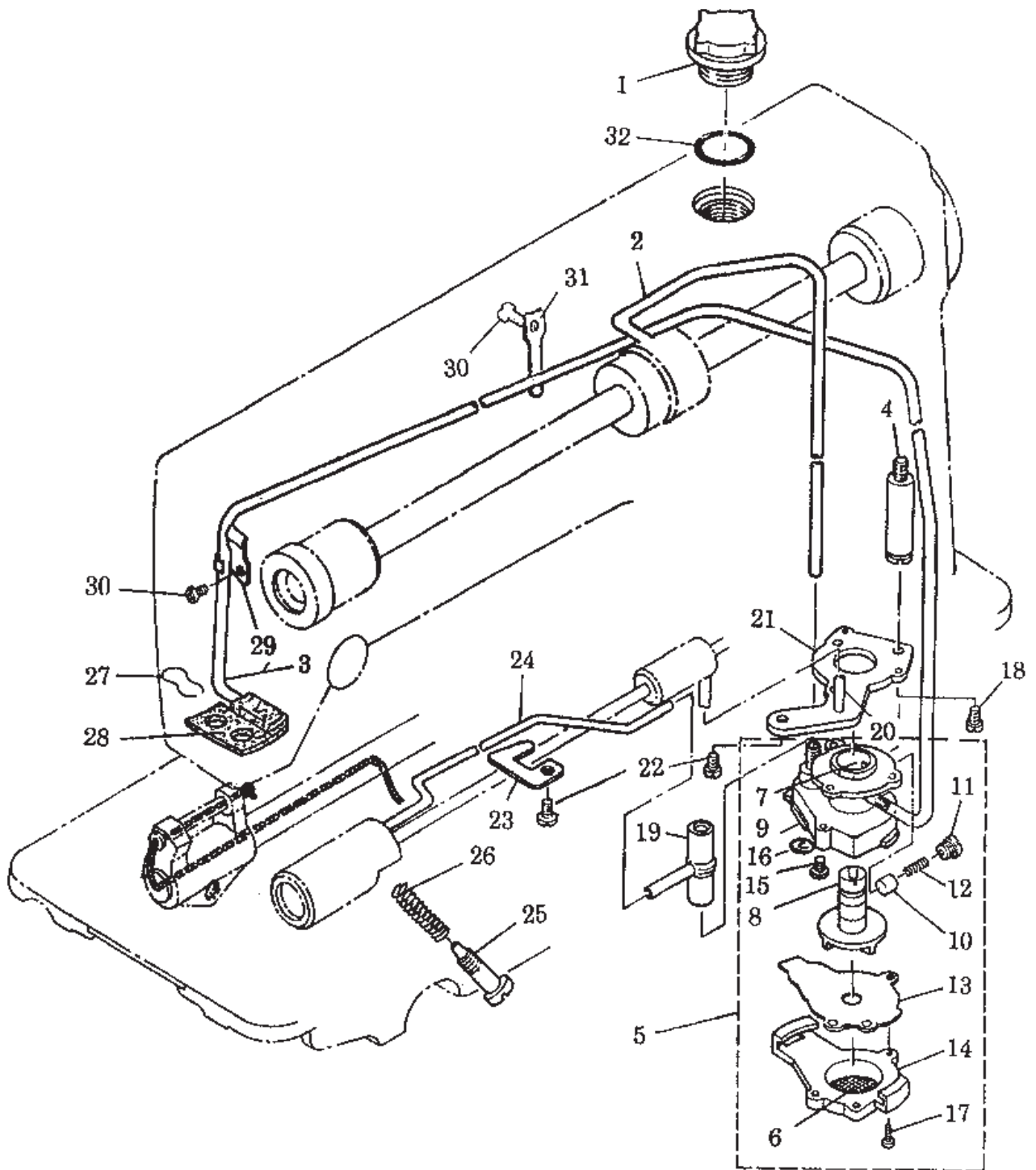

OIL RESERVOIR & KNEE LIFTER ASSEMBLY DRAWING AND PARTS LIST

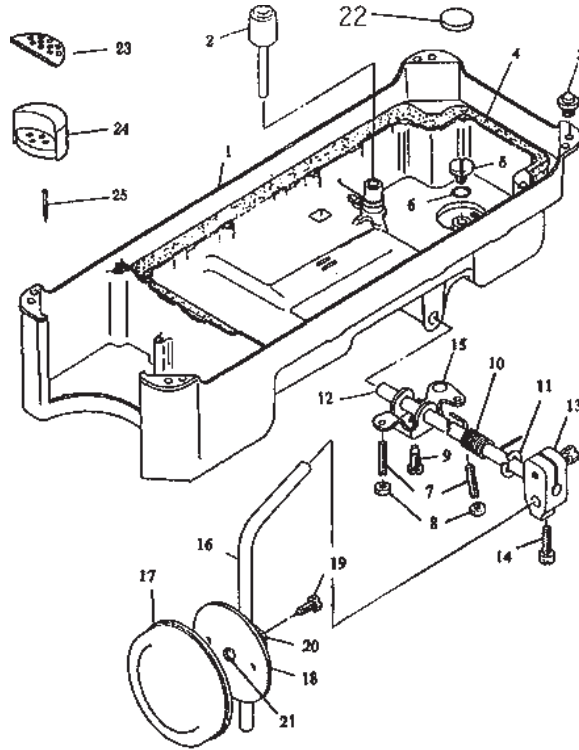

Ref. No.	Part No.	Description	Amt. Req.
1	01.07.1(110-23009)	Oil reservoir	1
2	01.07.2(110-24304)	Knee press lifter rod	1
3	01.07.3(110-23207)	Rubber cushion	4
4	01.07.4(110-23108)	Gasket	1
5	01.07.5(SS-6700710-SH)	Screw	1
6	GB1235-76(RO-0982401-00)	O-ring	1
7	01.07.6(SS-8153010-SR)	Screw	2
8	(NS-6150430)	Nut	2
9	01.07.7(SS-9151610-SR)	Screw	1
10	01.07.8(110-24106)	Spring	1
11	01.07.9(RE-1000000-KO)	Knee press lifter rod snap ring	1
12	01.07.10(110-24205)	Knee press shaft	1
13	01.07.11(110-24502)	Rubber joint	1
14	(SS-9182010)	Screw	2
15	01.07.12(110-24007)	Knee press lifter crank	1
16	01.07.13(B3419-122-000)	Knee press plate rod	1
17	01.07.14(B3431-552-000)	Knee press plate cover joint	1
18	01.07.15(110-23702)	Knee press plate	1
19	01.07.16(SS-9151540-SR)	Screw	1
20	01.07.17(110-23801)	Knee lifter tube holder	1
21	01.07.18(110-24403)	Knee lifter pad	1
22	01.07.19	Oil reservoir magnet	1
23	01.07.20	Oil reservoir felt cushion	2
24	01.07.21	Oil reservoir rubber cushion	2
25	01.07.22	Nail	2

MACHINE HEAD ACCESSORIES PARTS LIST AND ASSEMBLY DRAWING

Ref. No.	Part No.	Description	Amt. Req.
1	01.08.1	Machine hinge plate asm	2
2	01.08.2	Machine hinge plate	2
3	01.08.3	Nalil	4
4	01.08.4	Beltcover(front)	1
5	01.08.5	Beltcover(front) cap	1
6	01.08.6	Beltcover, rear asm	1
7	01.08.7	Beltcover (rear)	1
8	01.08.8	Beltcover(rear) cover asm	1
9	01.08.9	Wood screw	2
10	01.08.10	Beltcover(front) screw	2
11	01.08.11	Beltcover support	1
12	01.08.12	Screw	1
13	01.03.19	Needle	1
14	01.08.13	Screwdriver, large	1
15	01.08.14	Screw driver, medium	1
16	01.08.15	Screw driver, small	1
17	01.03.36	Bobbin	3
18	01.08.16	Machine head cover	1
19	01.08.17	Machine rest pin	1
20	01.08.18	Oil reservoir asm	1

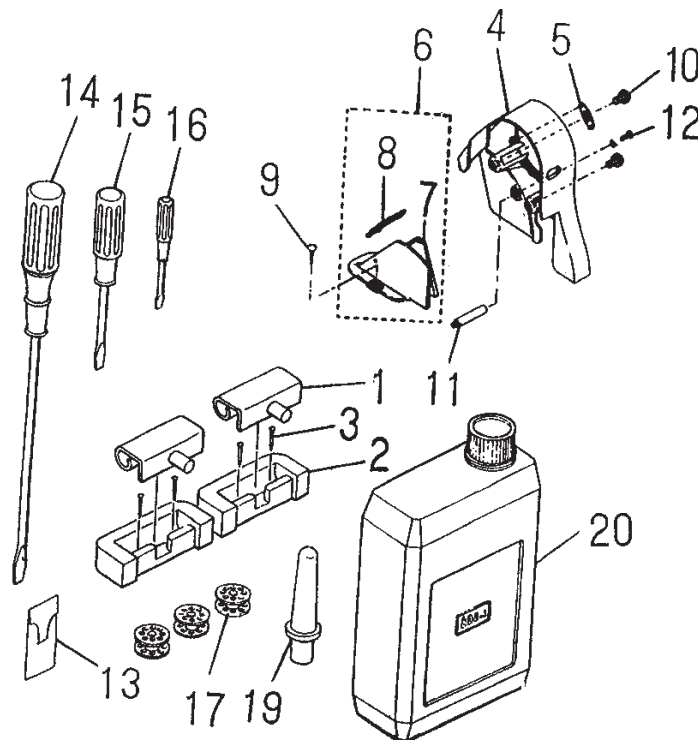

BOBBIN WINDER & THREAD STAND UNIT PARTS LIST

Ref. No.	Part No.	Description	Amt. Req.
1	GCX-01	Bobbin winder base asm	1
2	GCX-02	Thread winder base asm	1
3	GCX-03	Thread winder asm	1
4	GCX-04	Screw	1
5	GCX-05	Bobbin winder shaft	1
6	GCX-06	Connecting rod	1
7	GCX-07	Connecting rod pin	1
8	GCX-08	Bobbin winder frame rod	1
9	GCX-09	Bobbin winder frame pin	1
10	GCX-10	screw	1
11	GCX-11	Bobbin winder frame pin	1
12	GCX-12	Bobbin winder frame spring	1
13	GCX-13	Rubber brake	1
14	GCX-14	Presser plate	1
15	GCX-15	Screw	1
16	GCX-16	Bobbin winder spring	1
17	GCX-17	Hinge screw	1
18	GCX-18	Thread tension bracket asm	1
19	GCX-19	Screw	1
20	GCX-20	Bobbin winder tension disc collar	1
21	GCX-21	Tension disc	2
22	GCX-22	Tension spring	1
23	GCX-23	Thread tension stud nut	1
24	GCX-24	Screw	1
25	GCX-25	Washer	1
26	GB99-86	Wood screw	2
27	GB95-85	Washer	2
28	GCX-26	Thread hanger	2
29	GCX-27	Column cap	1
30	GCX-28	Spool rest rod,upper	1
31	GB5780-86	Screw	2
32	GB848-85	Washer	2
33	GCX-29	Column pipe connector	1
34	GB818-85	Screw	2
35	GB6170-86	Nut	4
36	GCX-30	Spool rest rod,lower	1
37	GCX-31	Washer	2
38	GB6173-86	Nut	1
39	GCX-32	Spool vibration stopper	2
40	GCX-33	Spool pin	2
41	GCX-34	Spool rest	2
42	GCX-35	Spool mat	2
43	GCX-36	Thread guide tube	2
44	GCX-37	Thread guide tube holder	2
45		Rubber Washer	1
46		Spool Support	1
47		Nut	2

BOBBIN WINDER & THREAD STAND UNIT ASSEMBLY DRAWING

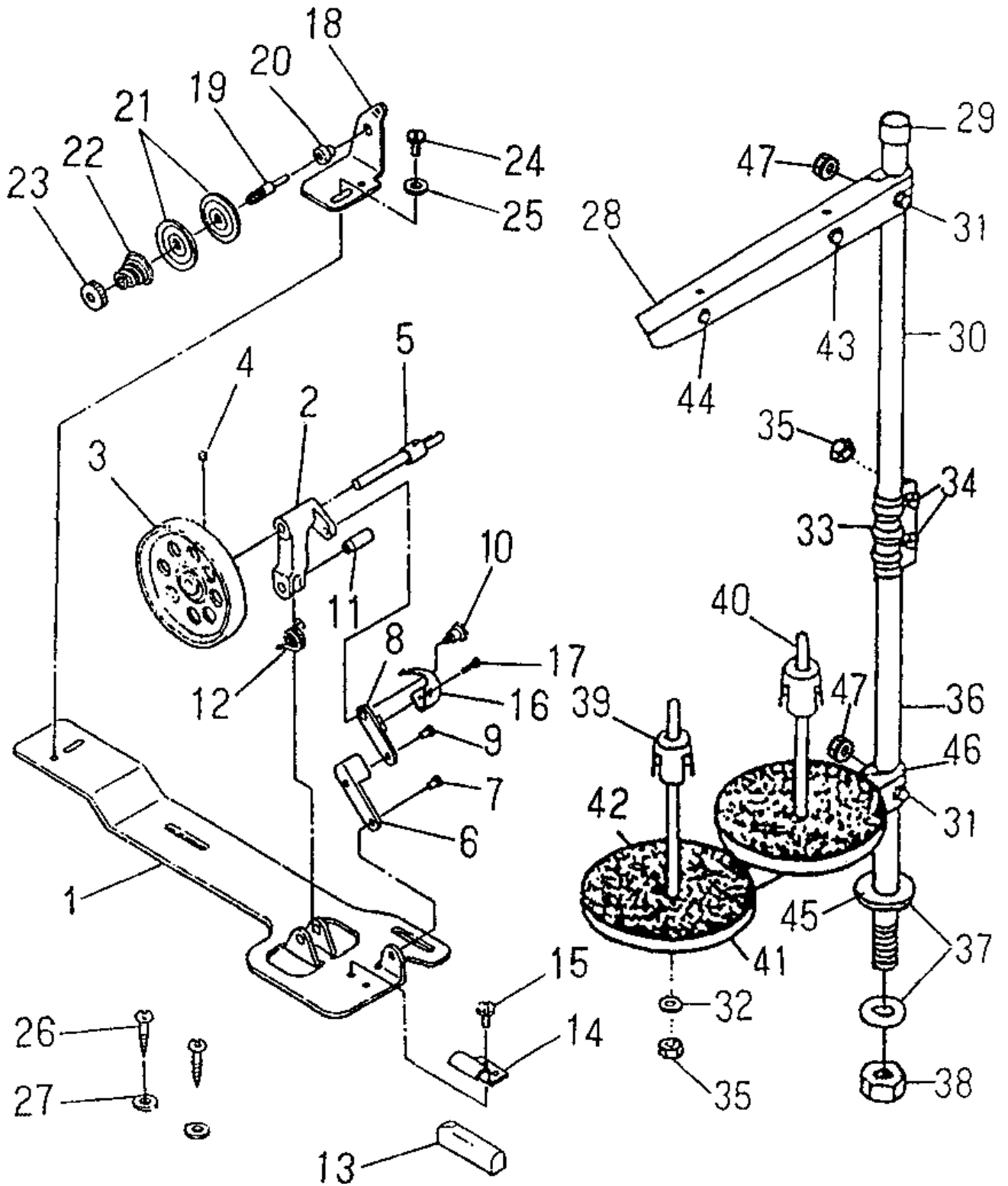



CHICAGO
Electric

**LIMITED 90 DAY
WARRANTY**

Harbor Freight Tools Co. makes every effort to assure that its products meet high quality and durability standards, and warrants to the original purchaser that this product is free from defects in materials and workmanship for the period of ninety days from the date of purchase. This warranty does not apply to damage due directly or indirectly, to misuse, abuse, negligence or accidents, repairs or alterations outside our facilities, or to lack of maintenance. We shall in no event be liable for death, injuries to persons or property, or for incidental, contingent, special or consequential damages arising from the use of our product. Some states do not allow the exclusion or limitation of incidental or consequential damages, so the above limitation of exclusion may not apply to you. THIS WARRANTY IS EXPRESSLY IN LIEU OF ALL OTHER WARRANTIES, EXPRESS OR IMPLIED, INCLUDING THE WARRANTIES OF MERCHANTABILITY AND FITNESS.

To take advantage of this warranty, the product or part must be returned to us with transportation charges prepaid. Proof of purchase date and an explanation of the complaint must accompany the merchandise. If our inspection verifies the defect, we will either repair or replace the product at our election or we may elect to refund the purchase price if we cannot readily and quickly provide you with a replacement. We will return repaired products at our expense, but if we determine there is no defect, or that the defect resulted from causes not within the scope of our warranty, then you must bear the cost of returning the product.

This warranty gives you specific legal rights and you may also have other rights which vary from state to state.

3491 Mission Oaks Blvd. • PO Box 6009 • Camarillo, CA 93011 • (800) 444-3353

Free Manuals Download Website

<http://myh66.com>

<http://usermanuals.us>

<http://www.somanuals.com>

<http://www.4manuals.cc>

<http://www.manual-lib.com>

<http://www.404manual.com>

<http://www.luxmanual.com>

<http://aubethermostatmanual.com>

Golf course search by state

<http://golfingnear.com>

Email search by domain

<http://emailbydomain.com>

Auto manuals search

<http://auto.somanuals.com>

TV manuals search

<http://tv.somanuals.com>