

# User's manual

Version 1.0 November 2002



**POWERPLAY PRO-XL HA4700**



**POWERPLAY PRO-8 HA8000**



[www.behringer.com](http://www.behringer.com)

# POWERPLAY PRO-XL HA4700/PRO-8 HA8000

## SAFETY PRECAUTIONS



**CAUTION:** To reduce the risk of electric shock, do not remove the cover (or back). No user serviceable parts inside; refer servicing to qualified personnel.

**WARNING:** To reduce the risk of fire or electric shock, do not expose this device to rain and moisture.



This symbol, wherever it appears, alerts you to the presence of uninsulated dangerous voltage inside the enclosure—voltage that may be sufficient to constitute a risk of shock.



This symbol, wherever it appears, alerts you to important operating and maintenance instructions in the accompanying literature. Please read the manual.

## DETAILED SAFETY INSTRUCTIONS:

All the safety and operation instructions should be read before the device is operated.

### Retain Instructions:

The safety and operating instructions should be retained for future reference.

### Heed Warnings:

All warnings on the device and in the operating instructions should be adhered to.

### Follow instructions:

All operation and user instructions should be followed.

### Water and Moisture:

The device should not be used near water (e.g. near a bathtub, washbowl, kitchen sink, laundry tub, in a wet basement, near a swimming pool etc.).

### Ventilation:

The device should be situated so that its location or position does not interfere with its proper ventilation. For example, the device should not be placed on a bed, sofa, rug, or similar surface that may block the ventilation openings, or used in a built-in installation, such as a bookcase or cabinet that may impede the flow of air through the ventilation openings.

### Heat:

The device should be situated away from heat sources such as radiators, heat registers, stoves, or other devices (including amplifiers) that produce heat.

### Power Source:

The device should only be connected to a power supply of the type described in the operating instructions or on the device.

### Grounding or Polarization:

This device must be grounded.

### Power Cords:

Power cords should be routed so that they are not likely to be walked on or pinched by items placed upon or against them, paying particular attention to cords and plugs, sockets, outlets and the point where they exit from the device.

### Cleaning:

The device should be cleaned only as recommended by the manufacturer.

### Non-use Periods:

The power cord of the device should be unplugged from the outlet when left unused for a long period of time.

### Debris and Liquid Entry:

Debris and/or liquids should be kept from entering the enclosure through openings.

### Damage Requiring Service:

The device should be serviced by qualified service personnel when:

- ▲ The power cord or the plug has been damaged; or
- ▲ Debris or liquid has entered the device; or
- ▲ The device has been exposed to rain; or
- ▲ The device does not appear to operate normally or exhibits a marked change in performance; or
- ▲ The device has been dropped, or the enclosure damaged.

### Servicing:

The user should not attempt to service the device beyond that which is described in the operating instructions. All other servicing should be referred to qualified service personnel.

# POWERPLAY PRO-XL HA4700/PRO-8 HA8000

## FOREWORD



Dear Customer,  
welcome to the team of BEHRINGER users, and thank you very much for expressing your confidence in us by purchasing the POWERPLAY PRO.

Writing this foreword for you gives me great pleasure, because it represents the culmination of many months of hard work delivered by our engineering team to achieve a very ambitious goal: to present two outstanding pieces of equipment, whose flexibility lets them find use in both studios and P.A. situations.

The task of designing our new POWERPLAY PRO certainly meant a great deal of responsibility, which we assumed by focusing on you, the discerning user and musician. Meeting your expectations also meant a lot of work and night shifts. But it was fun, too. Developing a product usually brings a lot of people together, and what a great feeling it is when all who participated in such a project can be proud of what they've achieved.

It is our philosophy to share our enjoyment with you, because you are the most important member of the BEHRINGER team. With your highly competent suggestions for new products you've made a significant contribution to shaping our company and making it successful. In return, we guarantee you uncompromising quality (manufactured under ISO9000 certified management system) as well as excellent technical and audio properties at an extremely reasonable price. All of this will enable you to give free rein to your creativity without being hampered by budget constraints.

We are often asked how we manage to produce such high-quality devices at such unbelievably low prices. The answer is quite simple: it's you, our customers! Many satisfied customers mean large sales volumes enabling us to get better purchasing terms for components, etc. Isn't it only fair to pass this benefit on to you? Because we know that your success is our success too!

I would like to thank all of you who have made the POWERPLAY PRO possible. You have all made your own personal contributions, from the developers to the many other employees at this company, and to you, the BEHRINGER user.

My friends, it's been worth the effort!

Thank you very much,

Uli Behringer

## TABLE OF CONTENTS

<b>1. INTRODUCTION</b> .....	<b>3</b>
1.1 Before you get started .....	3
1.1.1 Initial operation .....	3
1.1.2 Warranty .....	4
1.2 The user's manual .....	4
<b>2. CONTROL ELEMENTS</b> .....	<b>4</b>
2.1 Front panel .....	4
2.2 Rear panel .....	5
<b>3. APPLICATION GUIDELINES</b> .....	<b>5</b>
3.1 Using the MAIN IN connectors .....	5
3.2 AUX IN inputs (HA4700 only) .....	5
3.3 Using the DIRECT IN connector .....	6
3.4 Mono mode .....	6
3.5 MUTE function (HA4700 only) .....	6
3.6 Connecting multiple headphones .....	6
<b>4. AUDIO CONNECTIONS</b> .....	<b>6</b>
<b>5. SPECIFICATIONS</b> .....	<b>7</b>
<b>6. WARRANTY</b> .....	<b>9</b>

## 1. INTRODUCTION

Congratulations! With the BEHRINGER POWERPLAY PRO, you have acquired a high-end headphone amplifier. Both POWERPLAY PRO units were developed with the most demanding applications in mind: professional recording, radio and television studios, as well as CD/digital sound production. They were developed as benchmark units for judging mixdown quality as well as distribution amplifiers for flexible playback applications in studio environments.

### Balanced inputs and outputs

Both BEHRINGER POWERPLAY PROs feature electronically servo-balanced inputs and outputs. The servo function automatically recognizes when unbalanced pins are assigned. It internally modifies the nominal signal level, thus preventing any occurrence of signal level difference between inputs and outputs (6 dB correction).

 The following user's manual is intended to familiarize you with the unit's control elements, so that you can master all the functions. After having thoroughly read the user's manual, store it at a safe place for future reference.

### 1.1 Before you get started

The POWERPLAY PRO was carefully packed at the assembly plant to assure secure transport. Should the condition of the cardboard box suggest that damage may have taken place, please inspect the unit immediately and look for physical indications of damage.

 Damaged units should NEVER be sent directly to us. Please inform the dealer from whom you acquired the unit immediately as well as the transportation company from which you took delivery of the unit. Otherwise, all claims for replacement/repair may be rendered invalid.

# POWERPLAY PRO-XL HA4700/PRO-8 HA8000

## 1.1.1 Initial operation

Please make sure the unit is provided with sufficient ventilation, and never place the POWERPLAY PRO on top of an amplifier or in the vicinity of a heater to avoid the risk of overheating.

**Before plugging the unit into a power socket, please make sure you have selected the correct voltage:**

The fuse compartment near the power plug socket contains three triangular markings. Two of these triangles are opposite one another. The voltage indicated adjacent to these markings is the voltage to which your unit has been set up, and can be altered by rotating the fuse compartment by 180°. **ATTENTION: This does not apply to export models that were for example manufactured only for use with 120 V!**

**If you alter the unit's voltage, you must change the fuses accordingly. The correct value of the fuses needed can be found in the chapter "TECHNICAL DATA".**

**Faulty fuses must be replaced with fuses of appropriate rating without exception! The correct value of the fuses needed can be found in the chapter "TECHNICAL DATA".**

Power is delivered via the cable enclosed with the unit. All required safety precautions have been adhered to.

**Please make sure that the unit is grounded at all times. For your own protection, you should never tamper with the grounding of the cable or the unit itself.**

## 1.1.2 Warranty

Please take a few minutes and send us the completely filled out warranty card within 14 days of the date of purchase. You may also register online at [www.behringer.com](http://www.behringer.com). The serial number needed for the registration is located at the top of the unit. Failure to register your product may void future warranty claims.

## 1.2 The user's manual

This user's manual has been written in such a way to enable you an overview over the control elements of the unit and offers at the same time detailed information about possible applications. To facilitate quick look-ups, control elements have been described in groups depending on their function. Should you need detailed information about specific topics not covered in this manual, please visit our website at [www.behringer.com](http://www.behringer.com). For example, additional information about power amps and effects processors is found there.

### ATTENTION!

**We would like to bring your attention to the fact that extremely loud sound levels may damage your hearing as well as your headphones. Please lower all OUTPUT LEVEL knobs leftwards before powering up the unit.**

## 2. CONTROL ELEMENTS

This chapter contains descriptions of various control elements of your POWERPLAY PRO. All controls and connections are discussed in detail. Additionally, useful advice about their possible applications is also given.

The HA8000 has eight independent amplifiers for connecting headphones, while the HA4700 has four. The latter has several additional features not found in the HA8000 due to space considerations. The differences between the two units are explained in detail in the text sections that follow.

## 2.1 Front panel

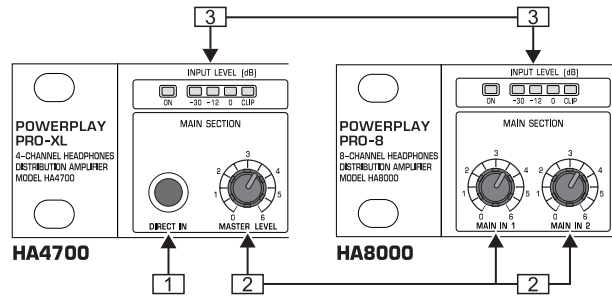

Fig. 2.1: Input section

**1** The *DIRECT IN* socket is used to feed in additional stereo signals. In the case of the HA4700, the signal brought in via the *DIRECT IN* input has the same priority as the *MAIN* signal. The HA8000 has a separate *DIRECT INPUT* connector for each channel **19** (see fig. 2.3). In the case of this model, the *MAIN* signal being fed in is automatically interrupted when the said input is in use.

**2** The *MASTER LEVEL* control governs the level of the input signal that is fed through the *MAIN INPUT* connectors on the back or through the *DIRECT IN* connector.

The HA8000 features two level controls (*MAIN IN 1/MAIN IN 2*), so that two separately controllable input signals can be connected. You select which of the two signals is monitored by using the *IN 1/IN 2* switches **14** in the respective channel sections.

**3** The 4-digit *INPUT LEVEL* display informs you about the input level signal and displays it in the range between -30 and 0 dB. When the unit is powered on, the *ON LED* lights up. You achieve the best input signal quality when its level is at the highest level just before it starts distorting. The clip LED should light up only during the highest signal peaks.

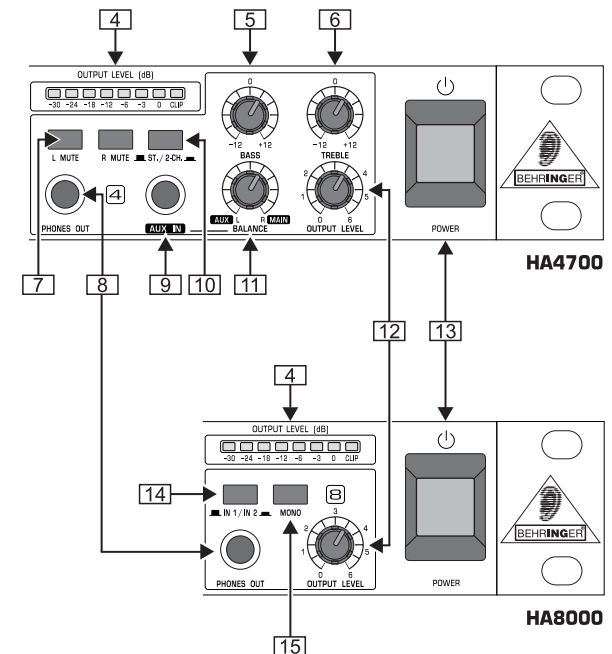

Fig. 2.2: Individual headphones amplifier sections

**4** The 8-digit *OUTPUT LEVEL* display informs you about the output signal level of each individual channel, and displays it in the range between -30 and 0 dB. When the clip LED lights up, lower the amount of gain applied to the individual channels to avoid distortion.

**5** The *BASS* control (HA4700 only) attenuates or boosts the low frequency portions of the signal (+/-12 dB).



# POWERPLAY PRO-XL HA4700/PRO-8 HA8000

- [6] The *TREBLE* control (HA4700 only) attenuates or boosts the high frequency portion of the signal (+/-12 dB).
- [7] The *L MUTE* and *R MUTE* switches allow you to mute the respective input signal, so that only the remaining input signal is audible (HA4700 only).
- [8] The *PHONES OUT* connector is connected in parallel to the output connectors [18] located on the rear, presenting an easily accessible additional monitor option for individual channels. This function is particularly helpful when the unit is permanently installed in a rack.
- [9] The *AUX IN* input is used to mix an additional input signal into the *MAIN IN* or *DIRECT IN* connectors (HA4700 only). Should you want to use this option on a mono signal, we recommend using the *ST./2-CH.* switch (position 2-CH, depressed) in order to hear the signal in both ears.
- [10] The *ST./2-CH.* switch is used to alternate whether input signals are audible in stereo (not depressed: *ST.*) or in mono (depressed: 2-CH.) The HA8000 features a *MONO* switch instead of a *ST./2-CH.* switch [15].
- [11] The *BALANCE* control (HA4700 only) regulates the stereo image of input signals, provided that the *AUX IN* input of one of the amp sections is not already in use. When the *AUX IN* section already has a signal assigned to it, the *BALANCE* control governs the ratio between *MAIN IN* (*DIRECT IN*) and *AUX IN* signal.

The HA8000 does not feature a *BALANCE* control.

- [12] Headphones volume of the individual amp sections is regulated using the *OUTPUT LEVEL* control. Both the left and the right channel are regulated simultaneously.
- [13] The *POWER* switch powers the *POWERPLAY PRO* on. You should always make sure that the *POWER* switch is in the "Off" position when initially connecting the unit to the mains.
-  **Please take note: Merely switching the unit off does not mean that it is fully disconnected from the mains. When not using the unit for prolonged periods of time, please unplug the unit's power cord from the power outlet.**
- [14] The *MAIN IN 1* or *MAIN IN 2* input signal is selected by using the *IN 1/IN 2* switch. When the *DIRECT INPUT* of the channel has a signal assigned to it, you can hear the said signal only (HA8000 only).
- [15] When you depress the *MONO* switch (HA8000 only), the signal is played in mono. Singers in particular appreciate this function because a mono signal is much less distracting to listen to than a comparable stereo signal. A mono signal makes spacial orientation during live performances easier.

## 2.2 Rear panel

- [16] Power is supplied via an *IEC* connector. The matching cable is provided with the unit.
- [17] *FUSE COMPARTMENT / VOLTAGE SELECTION.* Before connecting the unit to a power outlet, please make sure that the selected voltage matches your local voltage. When replacing fuses, please make sure that you always use fuses of the same type. Some units allow for switching between 230 V und 120 V. Please note: when connecting a unit intended for the European market to a 120 V power outlet, you must also replace the factory fuse with a higher-value fuse.
- [18] The *HEADPHONE OUT* connectors of the individual amp sections are also used for connecting headphones (HA8000: *PHONES OUTPUT*). The HA4700 features two additional headphones connectors per channel located on the rear; the HA8000 has one.

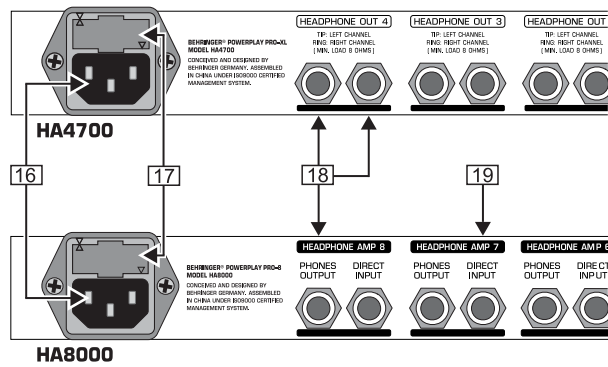

Fig. 2.3: Mains supply, fuses compartment and headphone outputs

- [19] Various input signals can be connected to the HA8000 by utilizing a separate *DIRECT IN* connection for each amp section, located on the rear. If a signal is fed into this connector, both *MAIN IN* signals will be muted.
- [20] These are the *MAIN OUT* connectors of the HA4700. The respective jacks and XLR connectors are wired in parallel. Via these connectors, you can link as many headphone amps as desired to allow for connection of additional headphones. The HA8000 has no *MAIN OUT* connectors. To connect additional units on a per-need basis, you can use HA8000's *PHONES OUTPUT* connectors.

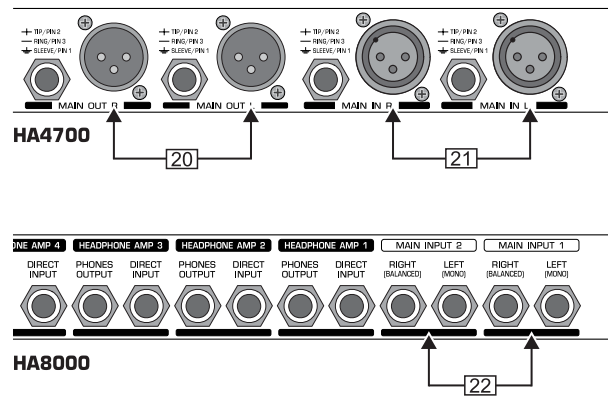

Fig. 2.4: MAIN IN and MAIN OUT connectors

- [21] The *MAIN IN* connectors of the HA4700 come as balanced 1/4" TRS and XLR connectors.
- [22] The HA8000 features only 1/4" TRS connectors for *MAIN INPUT 1* and *MAIN INPUT 2*.

## 3. APPLICATION GUIDELINES

### 3.1 Using the MAIN IN connectors

Connect a program source with the *MAIN IN* connectors located on the rear, and connect your headphones to an amp section of your choice. Set the *MASTER LEVEL* and *BALANCE* controls (HA4700) in the center position. The *MASTER LEVEL* control is used to lower or raise the volume level of all headphones which receive signals via the *MAIN IN* inputs and/or the *DIRECT IN* input. In the case of the HA8000, *MAIN IN* controls 1 and 2 regulate the input level of two separate input signals. The individual *OUTPUT LEVEL* controls are used for adjusting the desired channel volume only.

### 3.2 AUX IN inputs (HA4700 only)

As a general rule, the *AUX IN* inputs are used to add an extra input signal to the main signal, whereby the respective *BALANCE* control regulates the relative ratio of those signals to one another.

# POWERPLAY PRO-XL HA4700/PRO-8 HA8000

This way, you can for example effortlessly record vocals and feed in an already existing playback using your POWERPLAY PRO-XL HA4700. The playback signal is fed through the MAIN IN inputs, and the preamplified vocal signal is fed into the AUX IN connector. The respective BALANCE control should be set up in such a way that the singer gets a perfectly matched mix between the playback and the vocals, whereby the OUTPUT LEVEL control regulates the overall volume.

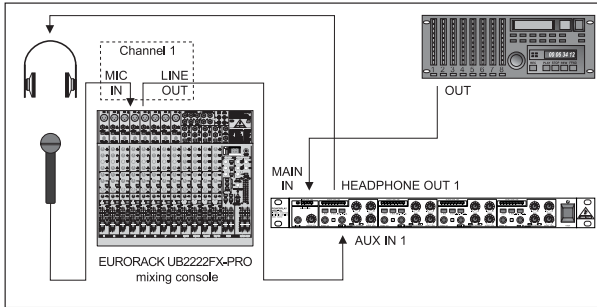

Fig. 3.1: Playback application in a studio

In addition to the usage of all channels via the MAIN input, each of the four amplifiers can also be used fully independently. To this end, you may also use the AUX IN inputs in conjunction with the BALANCE controls. When the BALANCE control is turned to the left ("AUX" position), the MAIN signal is faded out, and the AUX IN signals are fed into their respective amplifiers. Using individual amplifiers separately lets you provide individual mixes to up to four musicians.

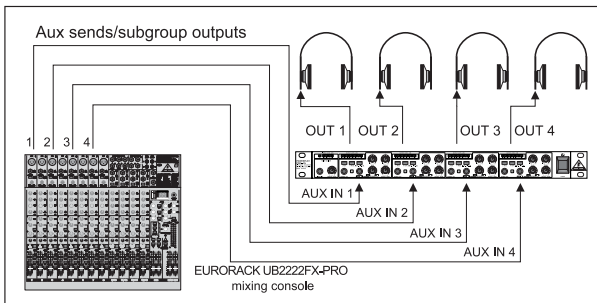

Fig. 3.2: Monitor live application

### 3.3 Using the DIRECT IN connector

The DIRECT IN connector (HA4700) is located on the left side of the front section. For example, you can use this connector to provide musicians with the signal of a DAT recorder or CD player. The HA8000 has a separate DIRECT IN connector for each amplifier (located on the rear). In the case of the HA8000, allocating a signal to this connector mutes the MAIN IN signal. The input level must be externally set in this case. This way, you can use each amplifier section for a separate headphone signal.

### 3.4 Mono mode

Stereo signals can often have an irritating effect in certain monitoring applications, especially when performing live. These negative effects are particularly apparent when both channels show great channel separation, i.e. a different information content coupled with varying volume levels. The ST./2-CH. switch (HA8000: the MONO switch) allows coupling the left and the right channels into a single mono signal, without needing a "Y"-adapter or a special cable.

### 3.5 MUTE function (HA4700 only)

When the ST./2-CH. switch is depressed, the unit is running mono. By depressing either one of the MUTE switches, the respective input's signal (i.e. either the left or the right input) is muted, while the signal not being muted can be heard on BOTH (left and right) headphone outputs. This allows you to feed two different program sources yet be able to listen to only one of them on a per-need basis.

### 3.6 Connecting multiple headphones

The HA4700 features three headphones connectors altogether, while the HA8000 has two. You can connect multiple headphones to an amp simultaneously, provided that the minimal output load impedance of the amp does not fall below 8 Ohms. In the case of the HA8000, the minimal output load impedance is 100 Ohms per amp.

When connecting two headphones, individual headphones should not have impedance lower than 16 Ohms; when connecting three headphones, individual headphones should not have impedance lower than 24 Ohms (HA4700). When connecting two headphones to the HA8000, the impedance of individual headphones should not fall below 200 Ohms.

Even though going under the above mentioned minimal impedances does not cause defective operation, you may experience a quality loss audible as lowered performance and distortion.

## 4. AUDIO CONNECTIONS

### Balanced XLR connectors

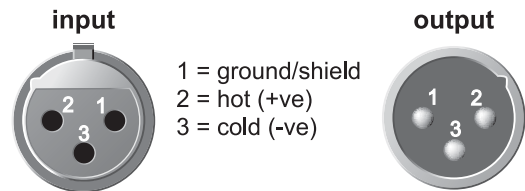

For unbalanced use pin 1 and pin 3 have to be bridged

Fig. 4.1: XLR connector

### Unbalanced 1/4" TS connector

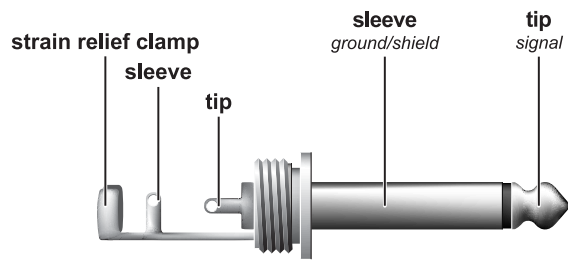
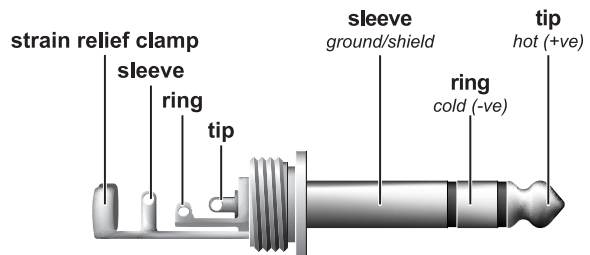

Fig. 4.2: 1/4" TS connector

### Balanced 1/4" TRS connector



For connection of balanced and unbalanced plugs, ring and sleeve have to be bridged at the stereo plug.

Fig. 4.3: 1/4" TRS connector

# POWERPLAY PRO-XL HA4700/PRO-8 HA8000

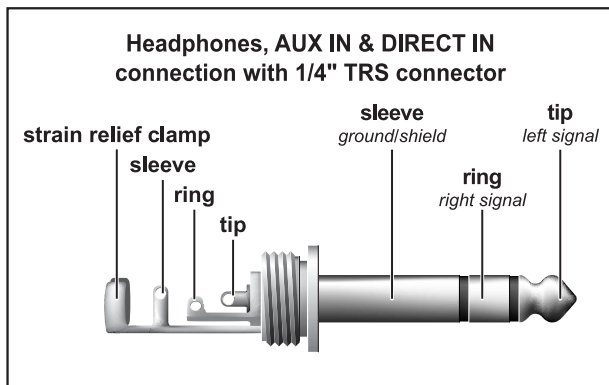



Fig. 4.4: 1/4" TRS connector for headphones operation

 Please assure that the unit is installed and operated only by people with an understanding of the unit's functions. During and after the installation always make sure that those handling the unit are themselves properly grounded. Failure to do so may cause undesirable or faulty operation through electrostatic discharge.

## 5. SPECIFICATIONS

	POWERPLAY PRO-XL HA4700	POWERPLAY PRO-8 HA8000
<b>AUDIO INPUTS</b>		
MAIN IN	HF-filtered, servo-balanced XLR- and 1/4" TRS connectors	HF-filtered, servo-balanced 1/4" TRS connectors
Input impedance	40 k $\Omega$ balanced, 30 k $\Omega$ unbalanced	40 k $\Omega$ balanced, 20 k $\Omega$ unbalanced
Max. input level	16 dBu balanced and unbalanced	
CMRR	typically 40 dB, >55 dB @ 1 kHz	
AUX IN	1/4" TRS connector (stereo)	-
Input impedance	5 k $\Omega$	-
Max. input level	+22 dBu	-
DIRECT IN	1/4" TRS connector (stereo)	
Input impedance	15 k $\Omega$	
<b>AUDIO OUTPUTS</b>		
MAIN OUT	XLR- and 1/4" TRS connectors, balanced	-
PHONES OUTPUT	1/4" TRS connector (stereo)	
<b>POWER AMPLIFIER</b>		
Max. output power	+24 dBm (load impedance 100 $\Omega$ ) +21 dBm (load impedance 8 $\Omega$ )	+24 dBm (load impedance 100 $\Omega$ )
Min. output load impedance	8 $\Omega$	100 $\Omega$
<b>SYSTEM SPECIFICATIONS</b>		
Frequency response	10 Hz to 150 kHz, +/-3 dB	
Noise	22 Hz to 22 kHz >90 dB @ 0 dBu	
Dynamic range	22 Hz to 22 kHz: 110 dB	
Distortion (THD)	0.006 % typ. @ +4 dBu, 1 kHz, Gain 1	

(continued on next page)

# POWERPLAY PRO-XL HA4700/PRO-8 HA8000

	POWERPLAY PRO-XL HA4700	POWERPLAY PRO-8 HA8000
<b>FUNCTION CONTROLS</b>		
Input Level	variable	
Balance per channel	mix between Aux and Main signals / balance between right and left channel	-
Output Level per channel	variable	
Treble	cutoff frequency: 6 kHz; range +/- 12 dB	-
Bass	cutoff frequency: 200 Hz, range +/- 12 dB	-
<b>FUNCTION SWITCHES</b>		
Stereo/2-Channel	switches between stereo mode and 2-channel mode	-
Main In 1/Main In 2	-	switches between MAIN Input 1 and MAIN Input 2
Left Mute	mutes the left signal of the respective channel	-
Right Mute	mutes the right signal of the respective channel	-
Mono	-	switches this section to mono
<b>DISPLAYS</b>		
Input Level	4-digit LED-display: -30/-12/0 dB/CLIP	
Output Level	8-digit LED-display: -30/-24/-18/-12/-6/-3/0 dB/CLIP	
<b>POWER SUPPLY</b>		
Mains voltage	USA/Canada 120 V~, 60 Hz	
	Europe/U.K./Australia 230 V~, 50 Hz	
	Japan 100 V~, 50 - 60 Hz	
	General export model 120/230 V~, 50 - 60 Hz	
Power consumption	34 W	30 W
Fuses	100 - 120 V~: T 630 mA H	
	200 - 240 V~: T 315 mA H	
Mains connection	Standard IEC receptacle	
<b>DIMENSIONS AND WEIGHT</b>		
Dimensions (H x W x D)	approx. 44.5 mm x 482.6 mm x 217 mm	
	approx. 1 ¾" x 19" x 8 ½"	
Weight	approx. 2.3 kg	approx. 2.35 kg
	approx. 5.08 lbs	approx. 5.19 lbs

BEHRINGER continuously strives to assure the highest quality standards possible. Required modifications may be implemented without prior notice. Technical data and the appearance of the unit may deviate from the above values and/or illustrations.



# POWERPLAY PRO-XL HA4700/PRO-8 HA8000

## 6. WARRANTY

### § 1 WARRANTY CARD/ONLINE REGISTRATION

To be protected by the extended warranty, the buyer must complete and return the enclosed warranty card within 14 days of the date of purchase to BEHRINGER Spezielle Studiotechnik GmbH, in accordance with the conditions stipulated in § 3. Failure to return the card in due time (date as per postmark) will void any extended warranty claims. Based on the conditions herein, the buyer may also choose to use the online registration option via the Internet ([www.behringer.com](http://www.behringer.com) or [www.behringer.de](http://www.behringer.de)).

### § 2 WARRANTY

1. BEHRINGER (BEHRINGER Spezielle Studiotechnik GmbH including all BEHRINGER subsidiaries listed on the enclosed page, except BEHRINGER Japan) warrants the mechanical and electronic components of this product to be free of defects in material and workmanship for a period of one (1) year\* from the original date of purchase, in accordance with the warranty regulations described below. If the product shows any defects within the specified warranty period that are not excluded from this warranty as described under § 3 and 4, BEHRINGER shall, at its discretion, either replace or repair the product using suitable new or reconditioned parts. In the case that other parts are used which constitute an improvement, BEHRINGER may, at its discretion, charge the customer for the additional cost of these parts.

2. If the warranty claim proves to be justified, the product will be returned to the user freight prepaid.

3. Warranty claims other than those indicated above are expressly excluded.

### § 3 RETURN AUTHORIZATION NUMBER

1. To obtain warranty service, the buyer (or his authorized dealer) must call BEHRINGER (see enclosed list) during normal business hours **BEFORE** returning the product. All inquiries must be accompanied by a description of the problem. BEHRINGER will then issue a return authorization number.

2. Subsequently, the product must be returned in its original shipping carton, together with the return authorization number to the address indicated by BEHRINGER.

3. Shipments without freight prepaid will not be accepted.

### § 4 WARRANTY REGULATIONS

1. Warranty services will be furnished only if the product is accompanied by a copy of the original retail dealer's invoice. Any product deemed eligible for repair or replacement by BEHRINGER under the terms of this warranty will be repaired or replaced within 30 days of receipt of the product at BEHRINGER.

2. If the product needs to be modified or adapted in order to comply with applicable technical or safety standards on a national or local level, in any country which is not the country for which the product was originally developed and manufactured, this modification/adaptation shall not be considered a defect in materials or workmanship. The warranty does not cover any such modification/adaptation, irrespective of whether it was carried out properly or not. Under the terms of this warranty, BEHRINGER shall not be held responsible for any cost resulting from such a modification/adaptation.

3. Free inspections and maintenance/repair work are expressly excluded from this warranty, in particular, if caused by improper handling of the product by the user. This also applies to defects caused by normal wear and tear, in particular, of faders, potentiometers, keys/buttons and similar parts.

4. Damages/defects caused by the following conditions are not covered by this warranty:

▲ improper handling, neglect or failure to operate the unit in compliance with the instructions given in BEHRINGER user or service manuals.

▲ connection or operation of the unit in any way that does not comply with the technical or safety regulations applicable in the country where the product is used.

▲ damages/defects caused by force majeure or any other condition that is beyond the control of BEHRINGER.

5. Any repair or opening of the unit carried out by unauthorized personnel (user included) will void the warranty.

6. If an inspection of the product by BEHRINGER shows that the defect in question is not covered by the warranty, the inspection costs are payable by the customer.

7. Products which do not meet the terms of this warranty will be repaired exclusively at the buyer's expense. BEHRINGER will inform the buyer of any such circumstance. If the buyer fails to submit a written repair order within 6 weeks after notification, BEHRINGER will return the unit C.O.D. with a separate invoice for freight and packing. Such costs will also be invoiced separately when the buyer has sent in a written repair order.

### § 5 WARRANTY TRANSFERABILITY

This warranty is extended exclusively to the original buyer (customer of retail dealer) and is not transferable to anyone who may subsequently purchase this product. No other person (retail dealer, etc.) shall be entitled to give any warranty promise on behalf of BEHRINGER.

### § 6 CLAIM FOR DAMAGES

Failure of BEHRINGER to provide proper warranty service shall not entitle the buyer to claim (consequential) damages. In no event shall the liability of BEHRINGER exceed the invoiced value of the product.

### § 7 OTHER WARRANTY RIGHTS AND NATIONAL LAW

1. This warranty does not exclude or limit the buyer's statutory rights provided by national law, in particular, any such rights against the seller that arise from a legally effective purchase contract.

2. The warranty regulations mentioned herein are applicable unless they constitute an infringement of national warranty law.

\* Customers in the European Union please contact BEHRINGER Germany Support for further details.

The information contained in this manual is subject to change without notice. No part of this manual may be reproduced or transmitted in any form or by any means, electronic or mechanical, including photocopying and recording of any kind, for any purpose, without the express written permission of BEHRINGER Spezielle Studiotechnik GmbH.

BEHRINGER and POWERPLAY are registered trademarks. ALL RIGHTS RESERVED.

© 2002 BEHRINGER Spezielle Studiotechnik GmbH.

BEHRINGER Spezielle Studiotechnik GmbH, Hanns-Martin-Schleyer-Str. 36-38, 47877 Willich-Münchheide II, Germany

Tel. +49 (0) 21 54 / 92 06-0, Fax +49 (0) 21 54 / 92 06-30

## Free Manuals Download Website

<http://myh66.com>

<http://usermanuals.us>

<http://www.somanuals.com>

<http://www.4manuals.cc>

<http://www.manual-lib.com>

<http://www.404manual.com>

<http://www.luxmanual.com>

<http://aubethermostatmanual.com>

Golf course search by state

<http://golfingnear.com>

Email search by domain

<http://emailbydomain.com>

Auto manuals search

<http://auto.somanuals.com>

TV manuals search

<http://tv.somanuals.com>