

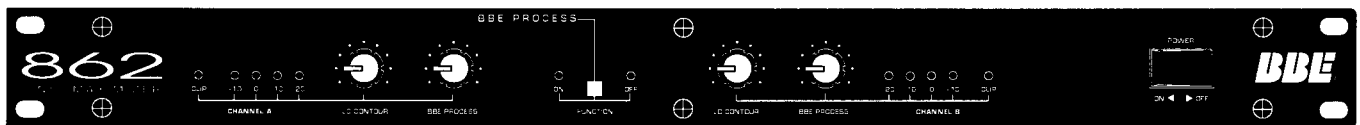

▲

*MODEL 862
SONIC MAXIMIZER
USER MANUAL*



Important Safeguards

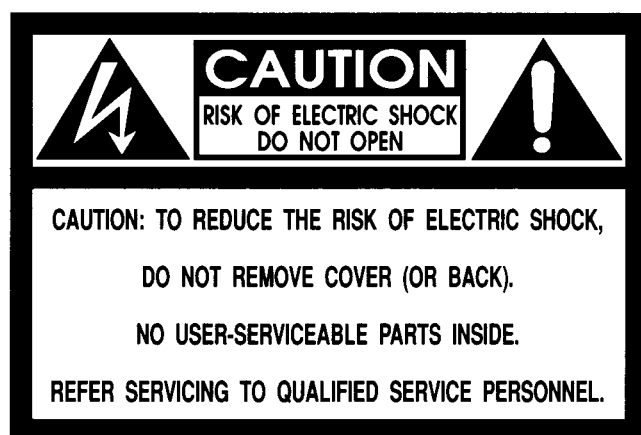

WARNING

To prevent fire or shock hazard, do not expose the unit to rain or moisture.

ATTENTION: RISQUE DE CHOC ELECTRIC- NE PAS OUVRIR.



The lightning flash with arrowhead symbol, within an equilateral triangle, is intended to alert the user to the presence of uninsulated "dangerous voltage" within the product's enclosure that may be of sufficient magnitude to constitute a risk of electric shock to persons.



The exclamation point, within a equilateral triangle is intended to alert the user to the presence of important operating and maintenance (servicing) instructions in the literature accompanying the appliance.

For your protection, please read these safety instructions completely before operating the appliance, and keep this manual for future reference.

Carefully observe all warnings, precautions and instructions on the appliance and described in the operating instructions supplied with the appliance.

INSTALLATION

Water and Moisture - Do not install the appliance near water: for example, near a bathtub, washbowl, kitchen sink, laundry tub, in a wet basement, or near a swimming pool.

Heat - Do not install the appliance near sources of heat such as radiators, heat registers, stoves, or other appliances that produce heat.

Ventilation - Situate the product so its location or position does not interfere with its proper ventilation. For example, you should not place the product on a bed, sofa, rug, or similar surface that might block the vent openings, or placed in a built-in installation, such as a bookcase or cabinet that might impede the flow of air through the ventilation openings.

Wall or Ceiling Mounting - If your appliance can be mounted to a wall or ceiling, mount it only as recommended.

USE

Power Source - Connect the appliance to a power supply only of the type described in the operating instructions or as marked on the appliance.

Grounding or Polarization - Do not defeat the grounding or polarization feature of the AC power cord. If your AC receptacle will not accept the power cord plug, contact your electrician to install a proper AC receptacle.

AC Receptacle - Check to make sure that the AC receptacle holds the power cord plug firmly and securely. If the power cord plug is loose, contact your electrician to replace the defective and unsafe AC

Power-Cord Protection - Route the power cord so that it is not likely to be walked on or pinched by having objects placed on it, paying particular attention to the plugs, receptacles, and the point where the cord exits from the appliance.

When not in use - Unplug the power cord of the appliance from the outlet when left unused for a long period of time. To disconnect the cord, pull it out by grasping the plug. Never pull the plug out by the cord.

Foreign Objects - Be careful that foreign objects and liquids do not enter the enclosure through openings.

SERVICE

Unplug the appliance from the wall outlet and consult qualified service personnel when:

- the power cord or the plug has been damaged.
- a solid object or liquid has fallen into the cabinet.

- the appliance has been exposed to rain or moisture.
- the appliance does not appear to operate normally or exhibits a marked change in performance.
- the appliance has been dropped, or the enclosure damaged.

Do not attempt to service the appliance beyond that described in the operating instructions. For all other servicing, refer to qualified service personnel **only**.



TABLE OF CONTENTS

Precautions.....	I
Product Description.....	1
Controls/Connections.....	2-4
General Operation/Applications.....	5-10
Service/Warranty Information.....	11
Calibration.....	12
Specifications.....	5
Schematic Diagram.....	13-19

Congratulations on your purchase of the **BBE 862 Sonic Maximizer**, a balanced, two channel signal processor that will benefit any sound reproduction system. Program material will have sparkle and unmistakable clarity. Lower frequencies, such as a bass guitar, will be more evident in the mix. Voices will be crystal clear. Guitar and keyboard notes will have greater integrity and be more distinct from each other. If classical music is your forte, listen to your favorite symphony and feel as though you are the conductor. Rap music will take on new dimensions with a thunderous, yet tight thump which cannot be achieved with any other sound processor. The **BBE 862's** flexible design will allow it to be configured into any system. Whether live sound reproduction or in recording studios, the **BBE 862** will be a welcome addition.

The following features will make the **BBE 862** attractive to sound engineers, players and listeners:

1. Independent **PROCESS** and **LO CONTOUR** control for each channel to accommodate mono or stereo configurations.
2. A **Function Switch** to allow for the comparison of the BBE Processed signal to the unprocessed signal.
3. Quarter inch stereo **Phone** jacks and **XLR** connectors to allow for easy, balanced configuration into any sound system.
4. **Clip LED** to monitor the incoming signal level.
5. A Four Level LED indicator to monitor the output of the **BBE 862 Sonic Maximizer**.

IMPORTANT

Before you begin, please check the contents within this box to insure that included are:

1. The **BBE 862 Sonic Maximizer**.
2. Four **Rubber Feet** for "Table Mount" applications
3. The **BBE 862 User's manual**.

If any of these items are found to be damaged or missing, immediately contact the **BBE** dealer from whom the unit was purchased.

Before you begin, please read this manual. It will help you use the **BBE 862** more effectively and answer most of the common questions that our service department receives. But if you still have questions, please call our service department at (714) 897-6766.

HOW THE BBE PROCESS WORKS

The BBE Process has been designed to make music programs more intelligible and life-like than normally achieved with existing audio systems. The BBE Process works dynamically by boosting the harmonic content of the music program, as determined by the signal input, and imparting a linear phase shift across the audio spectrum. The phase shift allows for a separation of the high, mid and low frequencies so that they do not arrive at the speaker network at precisely the same time. This prevents the higher frequencies from being smothered. (As the phase shift is minimal, 2 milliseconds, it is not perceived as a delay or echo.) The amount of harmonic amplification is variable as selected by the **PROCESS** knob, to achieve crisp, tight music program. The **LO CONTOUR** knob is a bass frequency adjustment. When turned clockwise, the **LO CONTOUR** will add power and warmth to the music program. If your musical tastes require the bass frequencies be reduced, turn the knob counter-clockwise.

Although the majority of the process is achieved with the higher frequencies of the music program, the BBE Process will make a significant difference with the entire program. For example: An "A" at 440Hz on a guitar is fundamentally the same note as an "A" at 440Hz on a piano. What allows a listener to identify the respective instruments is the harmonic content. By realigning the phase relationship and amplitude of the harmonic frequencies, the distinctive sound of a guitar, a piano, or any musical instrument, is much more evident.

FRONT PANEL CONTROLS AND CONNECTIONS

NOTE: BOTH CHANNELS OF THE BBE 862 ARE INDEPENDENT FROM EACH OTHER AND MAY PROCESS A STEREO SIGNAL SOURCE OR TWO INDEPENDENT SIGNAL SOURCES. NO DAMAGE WILL BE INFLICTED TO THE BBE 862 IF ONLY ONE CHANNEL IS UTILIZED.

CHANNEL A

1. **LED DISPLAY:** The LED display is used to indicate the output signal level of the **BBE 862**. Each number on the front panel corresponds to the output signal level, measured in decibels. Example: The **"+10"** indicates a 10dBu signal level, "0" refers to 0dBu, and so on. Once an input signal level has been established, increasing the **BBE PROCESS** and **LO CONTOUR**, will increase the output

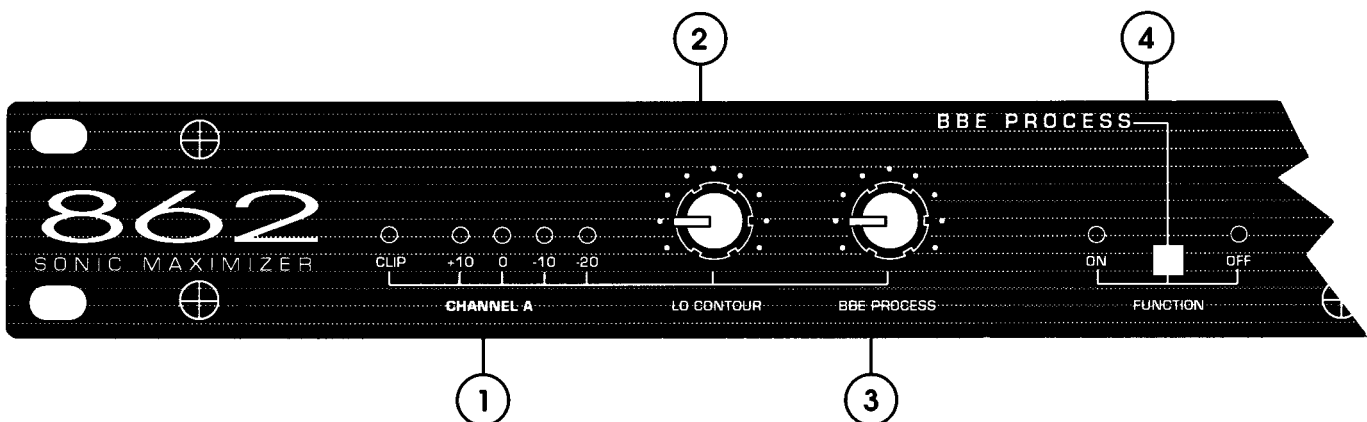

CHANNEL A cont.,

signal and cause more LEDs to illuminate. The **Clip LED** monitors the input signal level. The **Clip LED** will illuminate at +20dBu, giving a 3dBu warning of the impending distortion at +23dBu, the actual clip point.

- LO CONTOUR:** Each channel is equipped with a **LO CONTOUR** control. This control is a low frequency adjustment for the **BBE 862**. It provides a boost of 10dBu when turned to its maximum position (clockwise) at 50Hz. When turned to its minimum position (counter-clockwise) it reduces the 50Hz signal by 10dBu. The middle position would be flat or no change.
- PROCESS:** Each channel is equipped with a **BBE PROCESS** control. This control adjusts the BBE Process. The BBE Process gives the user a more detailed perception of tonality, added "bite" and an increase in clarity. The low frequency range of the program material will be tightened while the high end will be crystal clear without adding or creating any additional noise or harmonic distortion. When the knob is in its minimum position, completely counter-clockwise, no process is taking effect. Turning the knob clockwise will introduce the BBE Process. Adjust the knob to mix the desired amount of BBE Process to suit your taste. The BBE Process also has its own in/out switch for comparison of the processed to unprocessed signal located on the front panel. Experiment with the process. Use the BBE Process as an extension of the tone controls. The BBE Process is not an effect, but a sonic improvement. To start, set the **BBE PROCESS** knob to its 12 o'clock position, then adjust accordingly.
- FUNCTION:** This switch engages the BBE Process. When depressed, the "IN" position, the "GREEN" LED will illuminate, indicating that the BBE Process has been engaged. When in the "OUT" position, the "YELLOW" LED will illuminate, indicating that the BBE Process has been disengaged.
- CHANNEL B:** These controls function the same as the **CHANNEL A**.
- POWER:** This switch applies AC power to the **BBE 862 Sonic Maximizer**. When the **Power Switch** is in the "ON" position, either the "GREEN" or "YELLOW" **Function LED** will illuminate, as determined by the **Function Switch**, to indicate that power has been applied. When the **Power Switch** is not in the "ON" position, neither of the **Function LEDs** will illuminate.

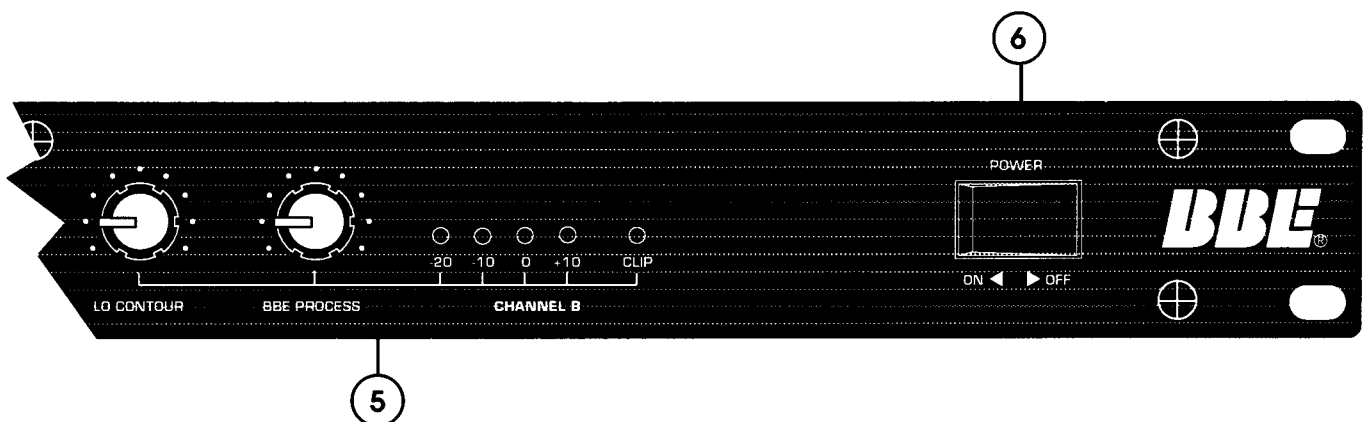

REAR PANEL

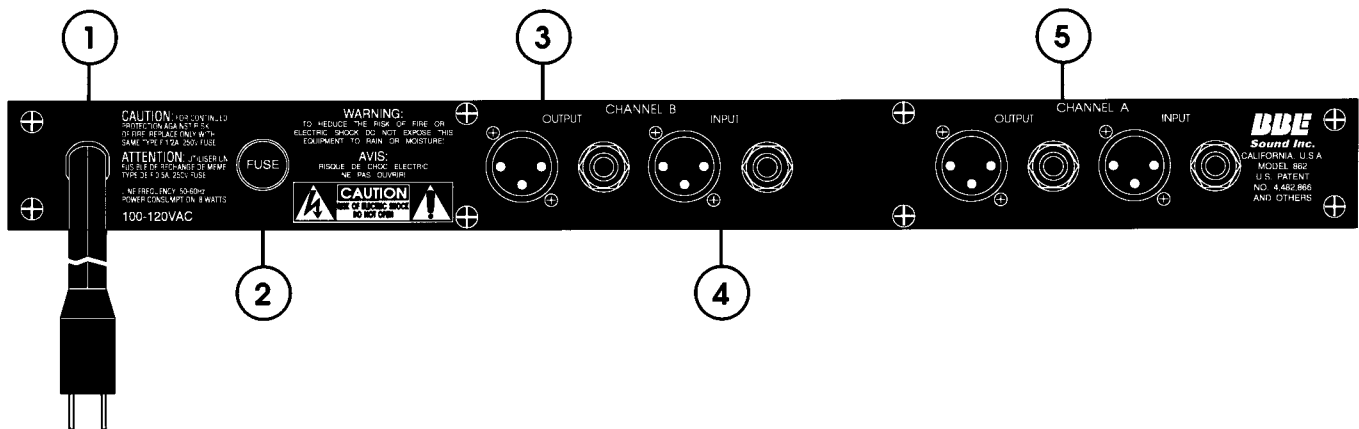

1. **POWER CORD:** U.S. Configuration: This is a standard two-pronged, polarized AC power cable for connection to any standard polarized 110Vac outlet. Plugs for other national configurations will vary.
2. **FUSE:** Replace **ONLY** with same type Fastblow fuse.
U.S., Canada and Japan models:
250Vac, 1/2A Fastblow
Standard model:
250Vac, .125A Fastblow

CHANNEL B

3. **OUTPUT:** The output of the **BBE 862** can be taken from the 1/4" stereo **Phone Jack** or the **XLR Jack**. Both are balanced and the same point electronically. This allows both outputs to be used simultaneously, eliminating the need for a "Y" cord in the event multiple, balanced outputs are required. The recommended single load level is at least 10k Ohms. If both outputs are being used, a minimum of a 22k Ohm load per device is required. (The "load" is determined by the input impedance of the next subsequent component in the signal chain.) The maximum output is rated at +23dBu. Pin #2 is considered the hot or "+" signal. The output impedance of the **BBE 862** is 600 ohms. **NOTE: Actual output level will vary due to the selected position of the BBE PROCESS, and the actual input signal level. If both the XLR and Phone jacks are being used, both must be balanced or unbalanced. Otherwise a loss of signal level will occur.**
4. **INPUT:** The input of the **BBE 862** is a balanced connection. Although it can be either a 1/4" stereo **Phone Plug** or an **XLR Plug**, it is recommended that only one input source is used. Both jacks are the same point electronically, however, due to the input/output impedance characteristics of most audio devices, a loss of signal may occur and/or damage to a component if both inputs are utilized. Pin #2 is considered the hot or "+" signal. The input impedance of the **BBE 862** is 14.7k Ohms. The maximum signal input is +23dBu.

5. **CHANNEL A:** These controls function the same as the **CHANNEL B**.



SPECIFICATIONS

Frequency Response,

process mode:	Program controlled
bypass mode:	20Hz to 20kHz, +/- 0.5dBu, 0dBu input
Signal to Noise:	-92dBu
THD, process mode:	less than 0.025% at -0dBu input, 20-20kHz
bypass mode:	less than 0.002% at -0dBu input, 20-20kHz
Maximum Output:	+23dBu (may vary due to control settings)
Input Impedance:	14.7k Ohms, balanced 1/4" stereo phone jack or XLR jack. Pin #2 is the hot or "+" signal.
Output Impedance:	600 Ohms, balanced 1/4" stereo phone jack or XLR jack. Pin #2 is the hot or "+" signal.
Sensitivity:	-45dBu for maximum process
Maximum Process:	+10dBu boost at 5kHz, 0dBu input
Lo Contour:	+10/-10dBu adjustment at 50Hz, 0dBu input

*** 0dBu = 0.775mVrms**

Power Requirements:	U.S., Canada & Japan models: 120VAC, 50/60Hz, 8 WATTS Standard model: 220VAC, 50/60Hz, 8 WATTS
Fuse:	Replace with the same type FASTBLOW fuse. U.S., Canada & Japan models: 250Vac, 1/2A Fastblow type fuse Standard model: 250Vac, .125A Fastblow type fuse
Dimensions:	19"(W) x 8.5"(D) x 1.7"(H)
Shipping Weight:	7lbs.

Note: Due to continuing product improvement, specifications and design are subject to change without



GENERAL OPERATION

THE BBE 862 IS A LINE LEVEL SIGNAL PROCESSOR AND IS TO BE CONNECTED PRIOR TO THE POWER AMP IN ANY AUDIO SYSTEM. SIGNIFICANT DAMAGE MAY BE INFLICTED TO THE BBE 862 OR ANY SUBSEQUENT COMPONENT IN THE SYSTEM IN THE EVENT THE OUTPUT OF A POWER AMP IS CONNECTED DIRECTLY TO THE BBE 862.

In order to reduce the risk of damage to any equipment, properly connect all cables and power cables before turning on any components in the system. Most important of all, **ALWAYS TURN ON THE POWER AMPLIFIER LAST TO AVOID DAMAGING THE SPEAKERS OR THE AMP.**

The **BBE 862** may be utilized in a number of different environments. Having balanced connections, the **BBE 862** is able to drive long signal lines with virtually no added noise or distortion. Nor will it have any adverse affect on the sound quality of the music program.

Both channels of the **BBE 862** are completely independent from each other. One channel of the **BBE 862** may be used at a time or each channel may process different signal sources simultaneously.

The effects loop is the ideal placement in the signal chain of a guitar application. In a pre-amp, keyboard or P.A. application, the **BBE 862** works best as the last component in the signal chain, just before the crossover or power amp.

Important: In pro audio applications, never connect the **BBE 862** into the effects loop. The inherent phase shift of the **BBE Process** will cause phase cancellation resulting in a partial loss of signal.

BBE AND EQUALIZATION

The most common question asked of the BBE Sound, Inc. service department is: "Where does the BBE Processor connect in the signal chain, before or after the equalizer?" Many people find that the same amount of equalization is no longer needed, if at all, when a BBE processor is used. Additionally, the amount of equalization used will help determine the **BBE 862's** proper location in the signal chain: if the EQ is being set to give the room a flat response as determined by a spectrum analyzer, the **BBE 862** will work properly before or after the EQ. (Placing the **BBE 862** after the EQ is recommended.) If the EQ is being used for drastic tone alteration, the recommended placement would be before the EQ. Neither of these configurations will harm the **BBE 862**.

When the **BBE 862** is being used in a single instrument application, guitar, keyboards, etc., it may be advantages to experiment with the proper placement of the BBE in the signal chain. The **BBE 862** will improve the sonic quality of the instrument and any effects that may be present as well. **Important: Generally, reverb and delay do not affect the BBE negatively. However, it is possible that with a large amount of effects added to an instrument that the BBE may process irregularly. If this occurs, reconnect the BBE 862 as the first item in the processor chain.**

Use the following illustrations as a starting point for proper placement of the **BBE 862**.

LIVE APPLICATION: NON POWERED MIXER

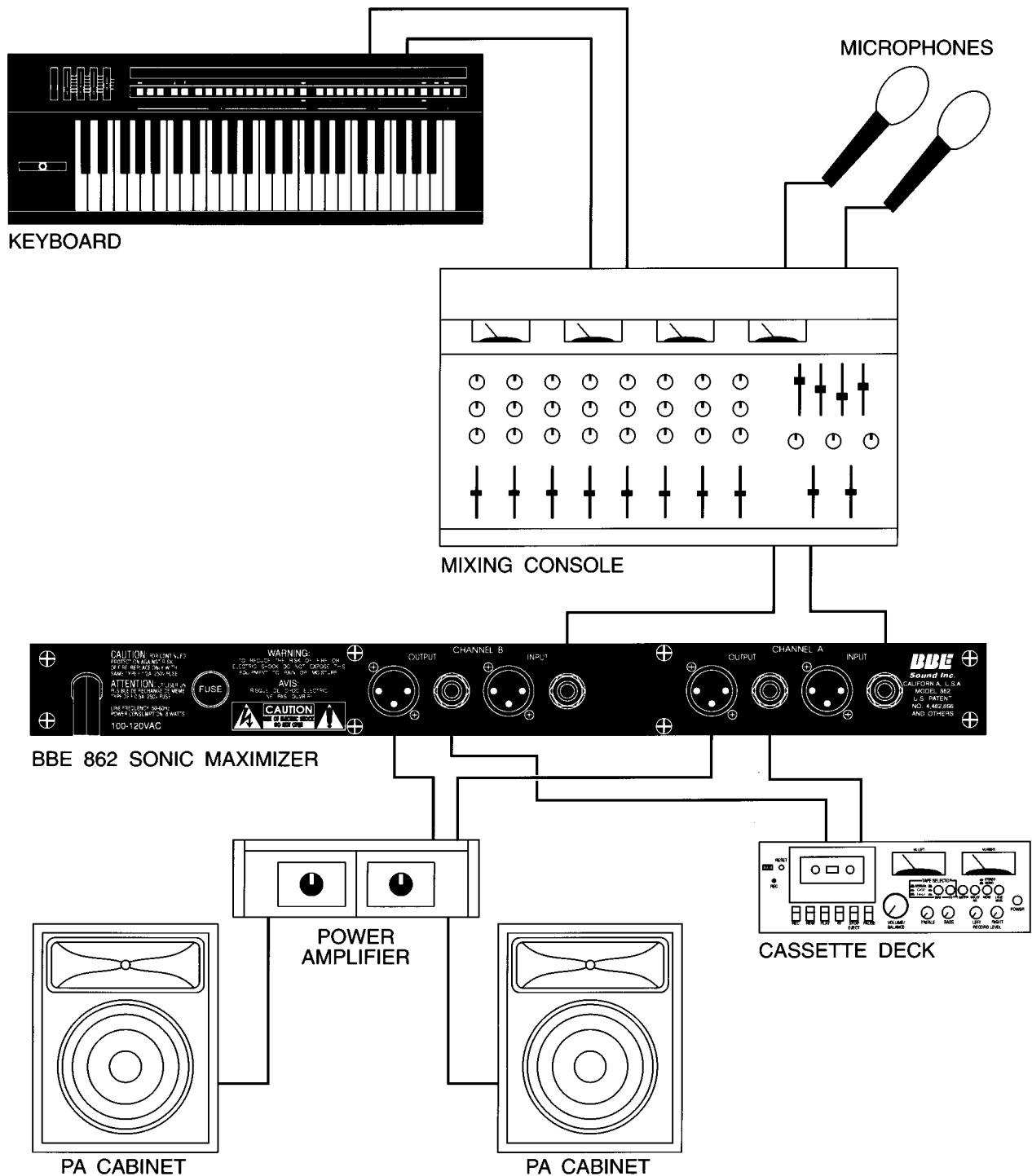

Connect the **BBE 862** to the output of the mixing console. The output of the BBE will drive either a crossover or a power amp directly. (If an equalizer is being used, refer to "**BBE AND EQUALIZATION**" section under "**GENERAL OPERATION.**")

▲ LIVE APPLICATION: POWERED MIXER

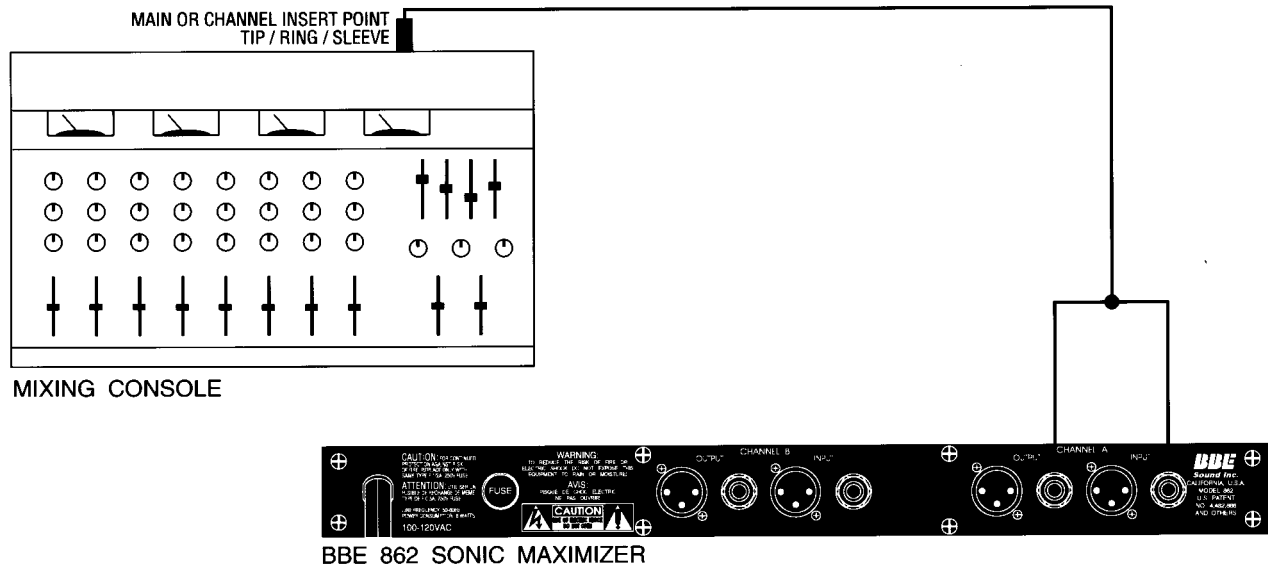
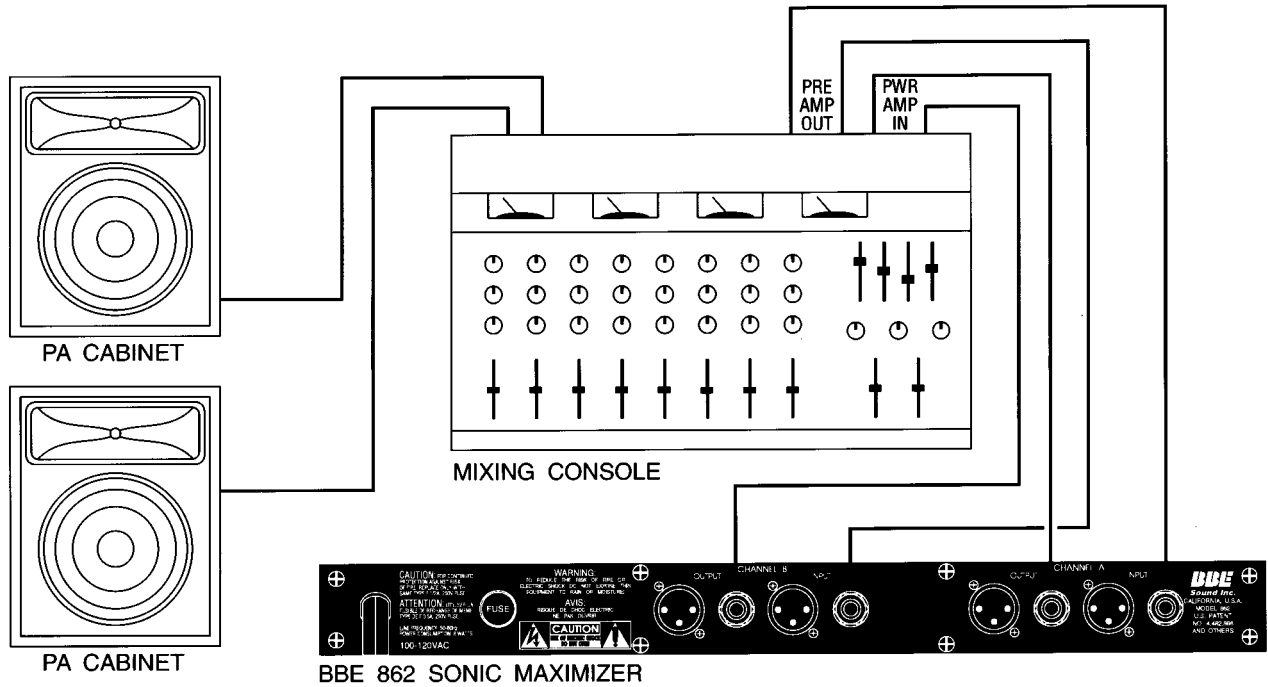

There are a couple of ways to configure the **BBE 862** into a powered mixer. The ideal method would be into "Pre-Amp Out/Power Amp In" section of the console. If your console does not have this option, use the main or channel insert points.

▲ RECORDING

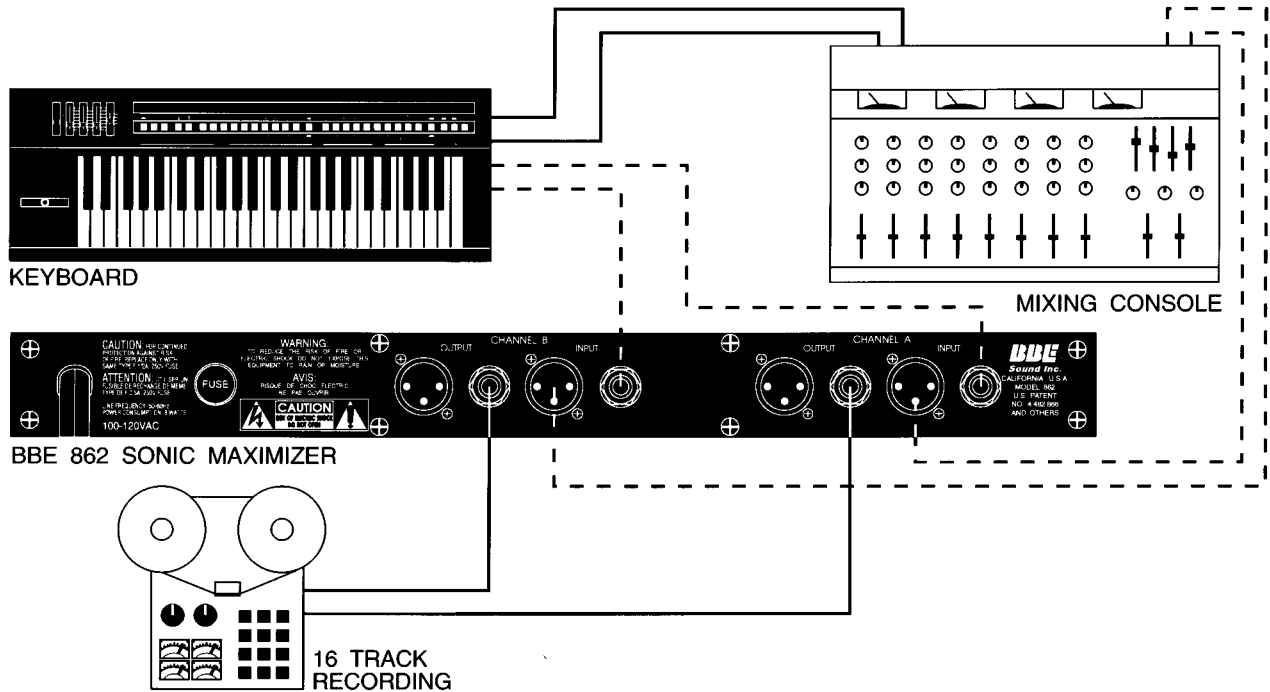

The **BBE 862** can be utilized in the recording studio on individual instruments or on groups of instruments to improve the sound quality.

▲ MASTERING OR DUBBING

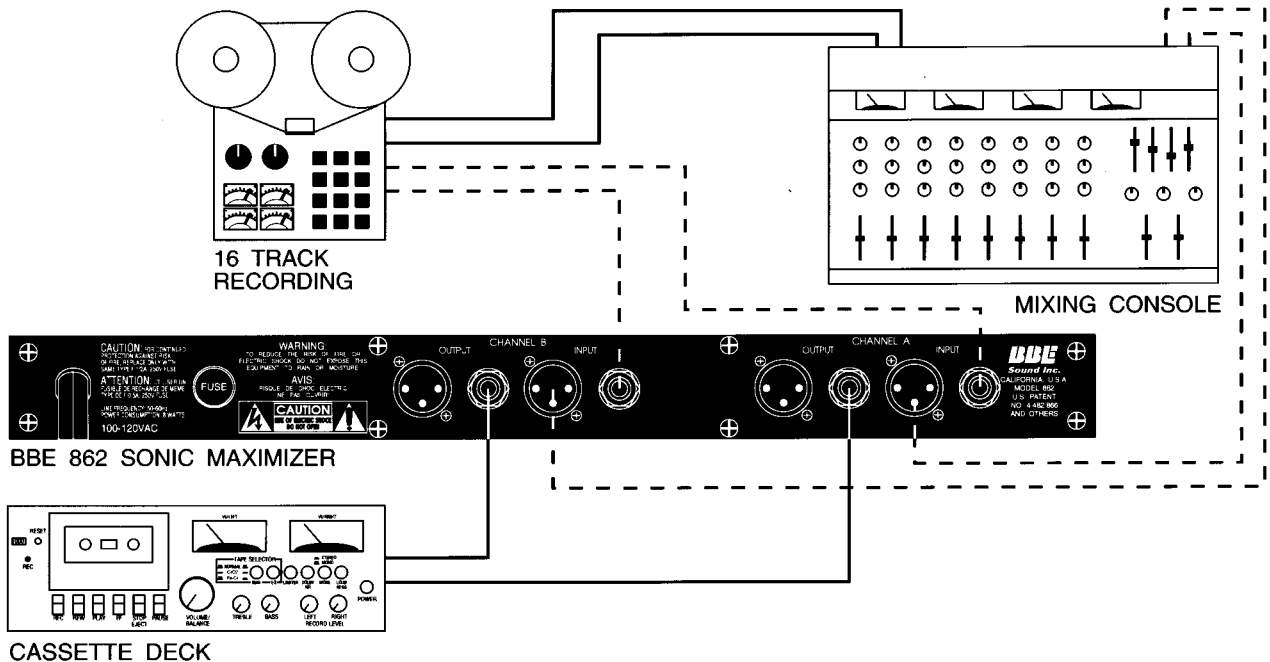

Use the **BBE 862** for mastering the recording. Even if the **BBE Process** has been used on individual tracks, an improvement of the total mix will be noticed.

INDIVIDUAL INSTRUMENTS

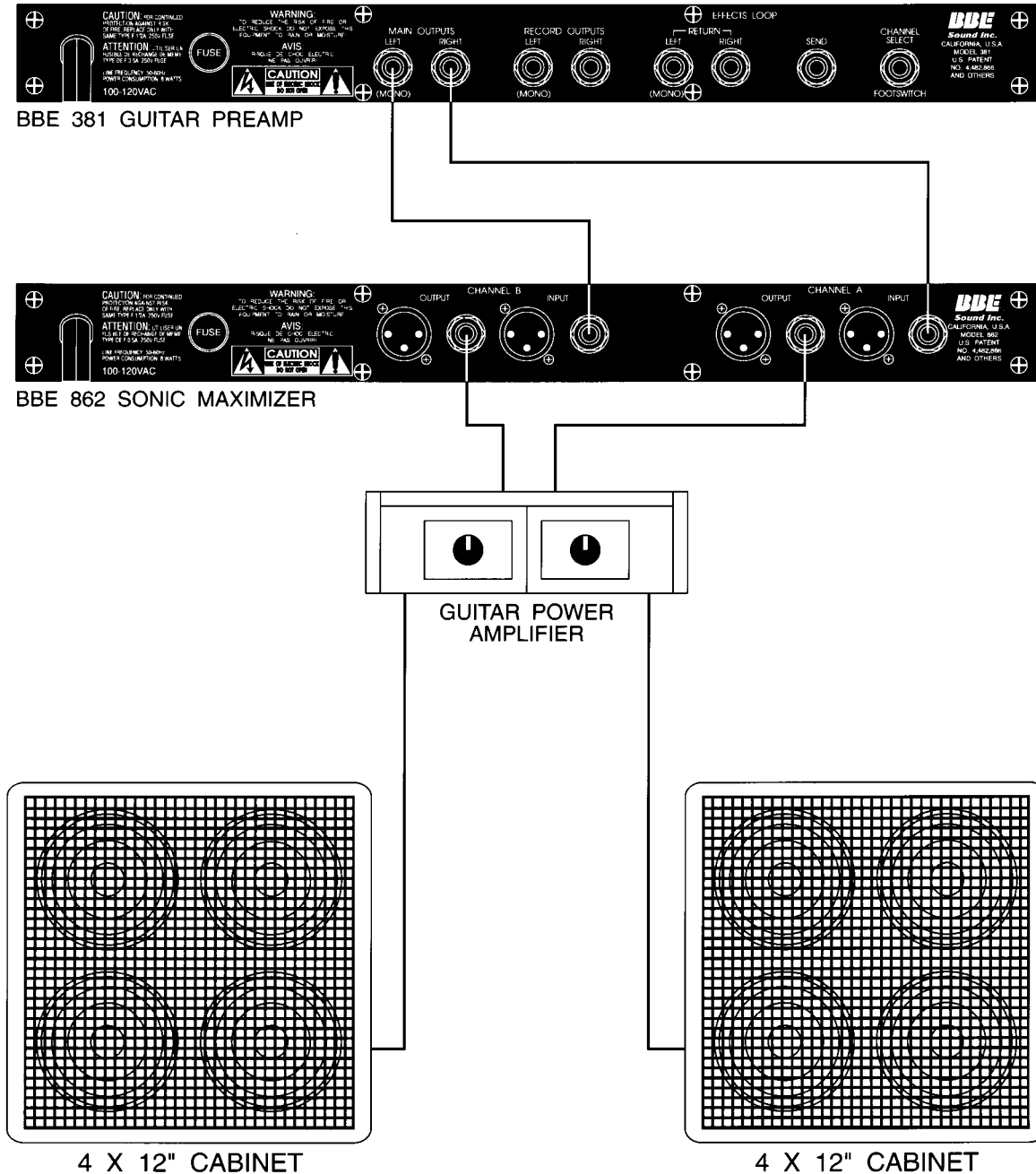

Use the **BBE 862** in the effects loop of a guitar amplifier or the output of a guitar pre-amp. For keyboards, the output of the sub-mixer will be the ideal location.

SOUND CONTRACTORS

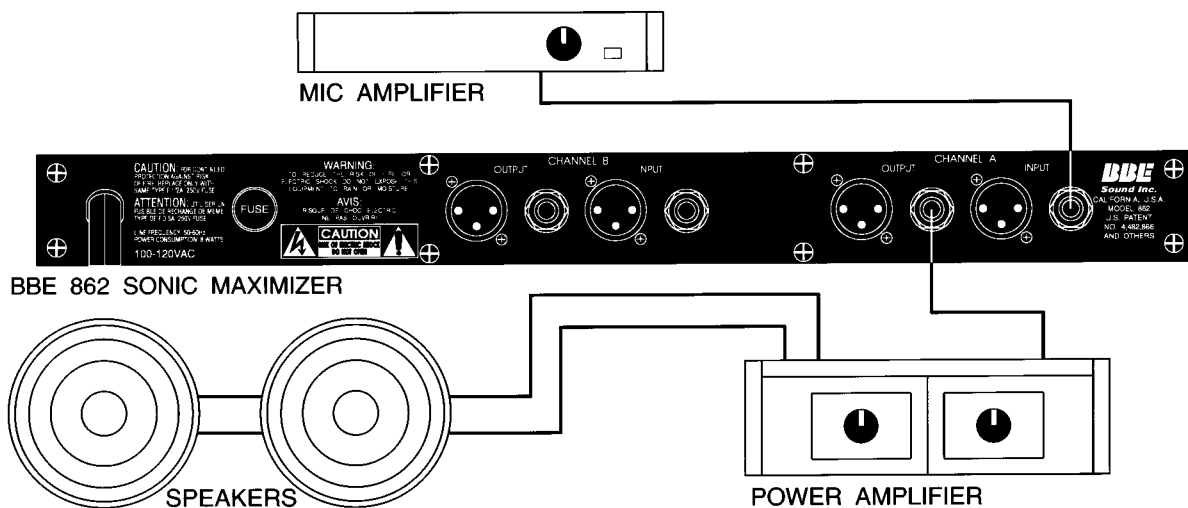

The **BBE 862** will accept the output level of most sound contractor type mixers.

D.J. APPLICATION

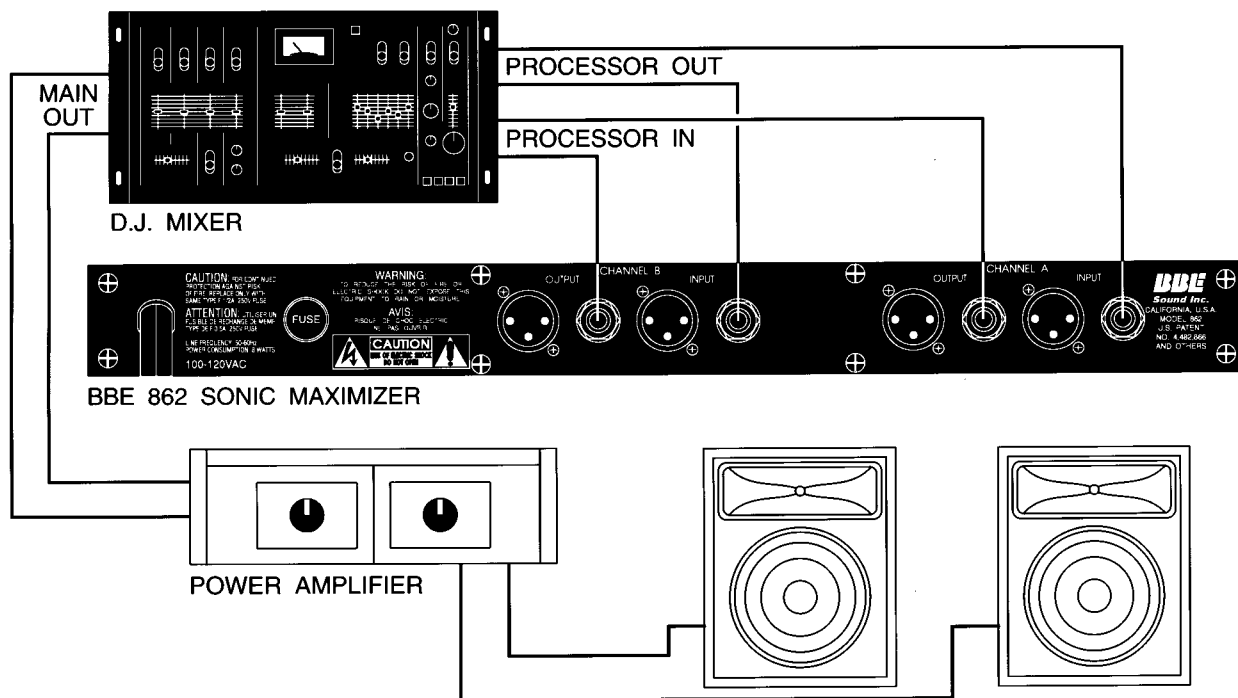

Connect the **BBE 862** into the processor loop of a pre-amp mixer and hear the music come alive!



SERVICE

We recommend that if at all possible a **BBE 862 Sonic Maximizer** which requires service be sent to our facility in Huntington Beach, CA. We request that a "RETURN AUTHORIZATION" be issued by the dealer from whom you purchased the unit. If this is not possible, call BBE Sound, Inc. directly at (714) 897-6766, to obtain a "RETURN AUTHORIZATION." Include a copy of the bill of sale with the unit when it is shipped to BBE Sound Inc., so that the service process can be expedited.

As the repair turnaround time is minimal, we request that the unit be sent directly to BBE Sound, Inc. This helps us add reliability data to our files for use in designing future products.



MAINTENANCE

Maintenance of the **BBE 862 Sonic Maximizer** is limited to proper cleaning of the unit with a mild household cleaner such as Formula 409tm or Windextm. The chassis and cover are steel finished with a durable polyurethane paint, while the front panel is an anodized aluminum extrusion.

There are no user replaceable parts and the unit should not be opened for any reason unless you are a qualified technician. Calibration should be performed if parts are replaced or if a performance check-out indicates a problem with calibration. Long term use has shown that over the life of the unit there is little or no drift of the components in the **BBE 862** which would cause a change in calibration. A conservative design philosophy has resulted in a piece of equipment which should give years of trouble-free service.



WARRANTY

Warranty registration of the unit to BBE Sound Inc. is not necessary. However, it is strongly recommended that a copy of the bill of sale is retained for future reference.

IT IS THE SOLE RESPONSIBILITY OF THE END USER TO PROVIDE THE BILL OF SALE OR OTHER MEANS OF PROOF OF PURCHASE TO VALIDATE THE WARRANTY IF WARRANTY SERVICE IS REQUIRED.

The **BBE 862 Sonic Maximizer** is warranted against defects in material and workmanship for a period of (5) five years from date of purchase from BBE Sound Inc. or from an authorized dealer.

During this period, we will repair units free of charge providing that they are shipped **prepaid** to BBE Sound, Inc., 5381 Production Drive, Huntington Beach, CA 92649. BBE Sound, Inc. will pay return UPS shipping charges within the USA. All charges related to non-US shipping, including customs clearance, will be billed. The warranty will be honored for the longer of either 90 days from the date of any service or the remainder of the original 5 Year factory warranty.

This warranty will be considered null and void by BBE Sound, Inc. if any of the following is found:

1. The equipment has been physically damaged.
2. The equipment shows signs of abuse.
3. The equipment has been electrically damaged by improper connection or attempted repair by the customer or a third party.
4. The equipment has been modified without authorization.
5. The bill of sale indicates that the purchase date of the equipment is not within the warranty period.

All non-warranty repairs are warranted for a period of 90 days from the date of service.

BBE Sound, Inc. is NOT LIABLE FOR CONSEQUENTIAL DAMAGES. Should the pre-amp fail to operate for any reason, our sole obligation is to repair the unit as described above.



CALIBRATION PROCEDURE FOR THE BBE 862

NOTE: THIS UNIT WAS CALIBRATED AT THE FACTORY. THIS IS FOR QUALIFIED SERVICE PERSONNEL ONLY.

EQUIPMENT REQUIRED: 1) Audio Signal Generator (sine wave) FOR SERIAL NUMBERS RXXXXX
2) Two digital voltmeter (DVM #1 and DVM #2) REVISION A.1 AUGUST 25, 1992

INITIAL SETTINGS:

- 1) **BBE PROCESS** control (**VR4, VR8**) to minimum (completely counter clockwise).
- 2) **LO CONTOUR** control and all internal potentiometers (**VR1 VR2, VR3, VR5, VR6, VR7**) to their middle positions.
- 3) **FUNCTION** to **IN** and **POWER** to **ON**.

Since both channels are identical in calibration, only channel A will be outlined. Channel B will be in brackets []. All tests are done with a signal level of 0dBu (**0.775Vrms**) except where noted.

The signal will be input into the corresponding channel connector marked **INPUT** (1/4" phone jacks balanced).
The DVM #1 will monitor the output of the corresponding channel marked **OUTPUT** (1/4" phone jack balanced).
The DVM #2 will be used to measure various test points in the test procedure. (relative to ground)

PROCEDURE:

OFFSET ADJUSTMENT:

- 1) With no signal present at the input (open) measure **TP1 [TP2]** with the DVM #2 set to DC volts.
- 2) Adjust **VR1 [VR5]** until DVM reads **0.00Vdc**.

POWER SUPPLY TEST:

- 1) With DVM set to DC volts measure the positive end of **C81**. It should be less then **+30Vdc**.
- 2) With DVM set to DC volts measure the negative end of **C82**. It should be less then **-30Vdc**.
- 3) With DVM set to DC volts measure **pin 8 of U11**. You should read **+15Vdc (+/- 0.5Vdc)**.
- 4) With DVM set to DC volts measure **pin 4 of U11**. You should read **-15Vdc (+/- 0.5Vdc)**.

UNITY ADJUSTMENT:

- 1) Input a signal of 5000Hz (0dBu) into the **input** and adjust **VR2 [VR6]** for a reading of **-0.500dBu** as read by DVM #1.
- 2) Input a signal of 500Hz (0dBu). Confirm that the DVM #1 reads **-0.500dBu (+/-0.500 dBu)**.

LO-CONTOUR TEST:

- 1) Input a signal of 50Hz (0dBu) into the **input** and adjust the **LO-CONTOUR** control to the **middle** position. DVM #1 should read **+1.00dBu (+/- 1.0dBu)**.
- 2) Turn the **LO-CONTOUR** to minimum. You should read **-13.5dBu** on DVM #1. (**+/- 1.0dBu**).
- 3) Turn the **LO-CONTOUR** to maximum. You should read **+9dBu** on DVM #1 (**+/- 1.0dBu**).

DETECTOR CHECK:

- 1) Input a 5000Hz signal 0.0dBu (0.775Vrms) into the input.
- 2) With DVM #2 (set to DC volts) measure **TP1 [TP2]**. The meter should read **-1.800VDC (+/- 50mVdc)**.
- 3) Input a 500Hz signal 0.0dBu (0.775Vrms) into the input. DVM #2 should read **-1.800VDC (+/- 50mVdc)**.

LED TEST:

- 1) Input a 5000Hz signal @ -20dBu (77.5mVrms) into the connector marked **CHANNEL A [B] INPUT**. The "**YELLOW**," **-20** LED should light.
- 2) Change the input signal to -10dBu (245mVrms.) The "**YELLOW**," **-10** LED should light.
- 3) Change the input signal to 0dBu (775mVrms.) The "**GREEN**," **0** LED should light.
- 4) Change the input signal to +10dBu (2.250Vrms.) The "**GREEN**," **+10** LED should light.
- 5) With the **FUNCTION** switched to the **IN** position the corresponding "**GREEN**" LED should light.
- 6) With the **FUNCTION** switched to the **OUT** position the corresponding "**YELLOW**" LED should light.

CLIP INDICATOR TEST:

- 1) Input a 500Hz signal with an amplitude of **+20dBu (7.750Vrms)** into the connector marked **INPUT CHANNEL A [B]**. Insure the corresponding **CLIP LED** is fully lit for each channel.
- 2) Change the input signal level to **+19dBu (6.904Vrms.)** The **CLIP LED** should not be lit for either channel.

XLR BALANCED/UNBALANCED TEST:

- 1) Measure **pins #2 and #3**. They should measure **-6dBu (+/-1)**.
- 2) Confirm the unit functions normally as described above.
- 3) Ground **pin #3** of the **XLR**. Insure the unit functions normally as described above.

BYPASS CHECK:

- 1) Switch the **FUNCTION** switch to the **OUT** position.
- 2) Since the model **862** has "hard wire" bypass whatever is present at the input of the device should be present at the output when in bypass mode. Verify that this is so.

DC VOLTAGE AT OUTPUT TEST:

- 1) Measure the output jacks to ground with the DVM set to DC volts. The voltage must be **0.00Vdc**. On the **XLR** connectors both **pins 2 and 3** should be **0.00Vdc**.

OFFSET DRIFT TEST:

- 1) With no signal present at the input (open) measure **TP1 [TP2]** with the DVM set to DC volts.
- 2) Insure this voltage is **0.00Vdc (+/- 0.25mVdc)**

END TEST

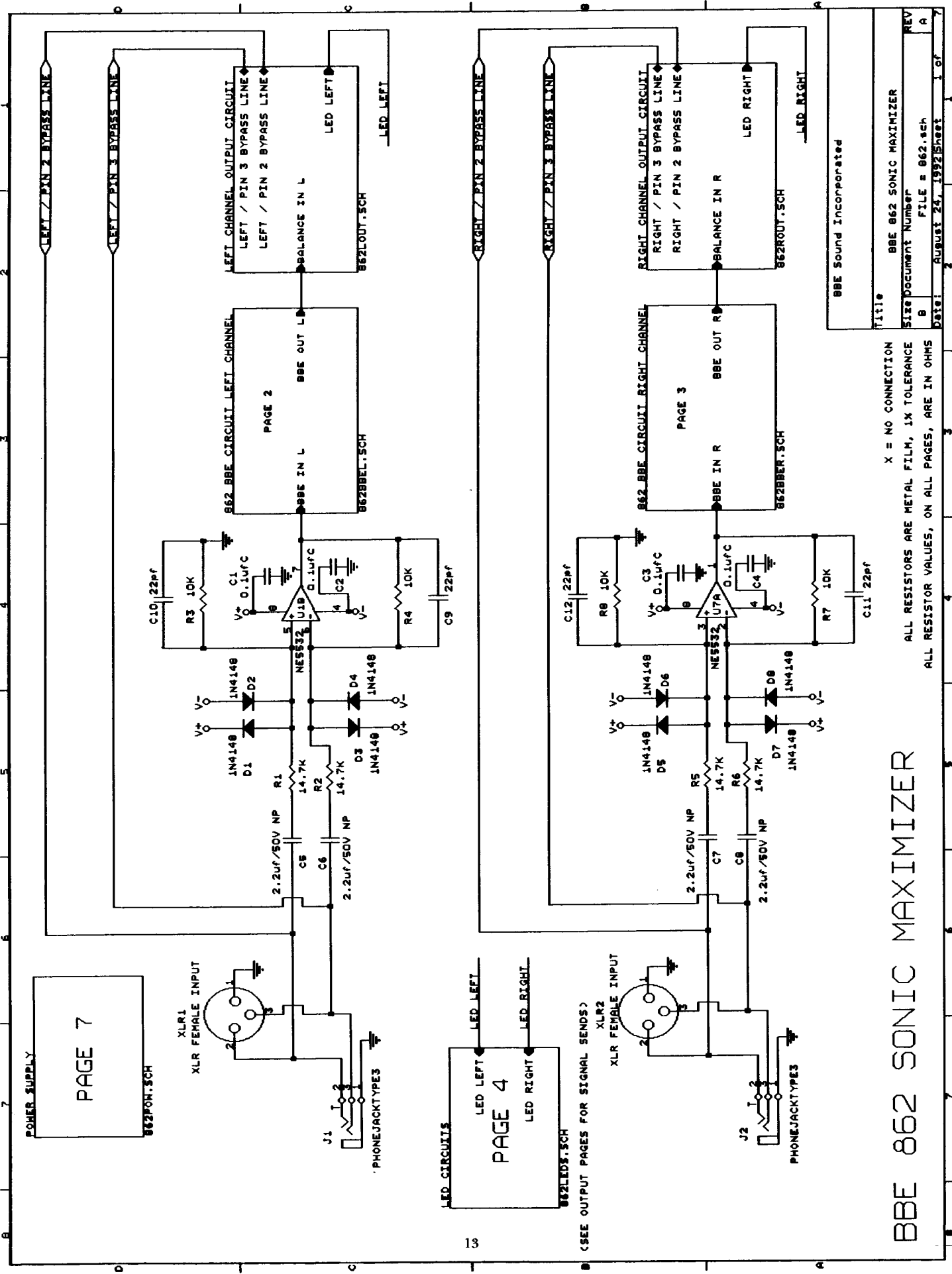

BBE Sound Incorporated	
Title	BBE 862 SONIC MAXIMIZER
Size	Document Number
B	FILE = 862.sch
Date:	August 24, 1992 Sheet 1 of 1
REV	A

X = NO CONNECTION
 ALL RESISTORS ARE METAL FILM, 1% TOLERANCE
 ALL RESISTOR VALUES, ON ALL PAGES, ARE IN OHMS

BBE 862 SONIC MAXIMIZER

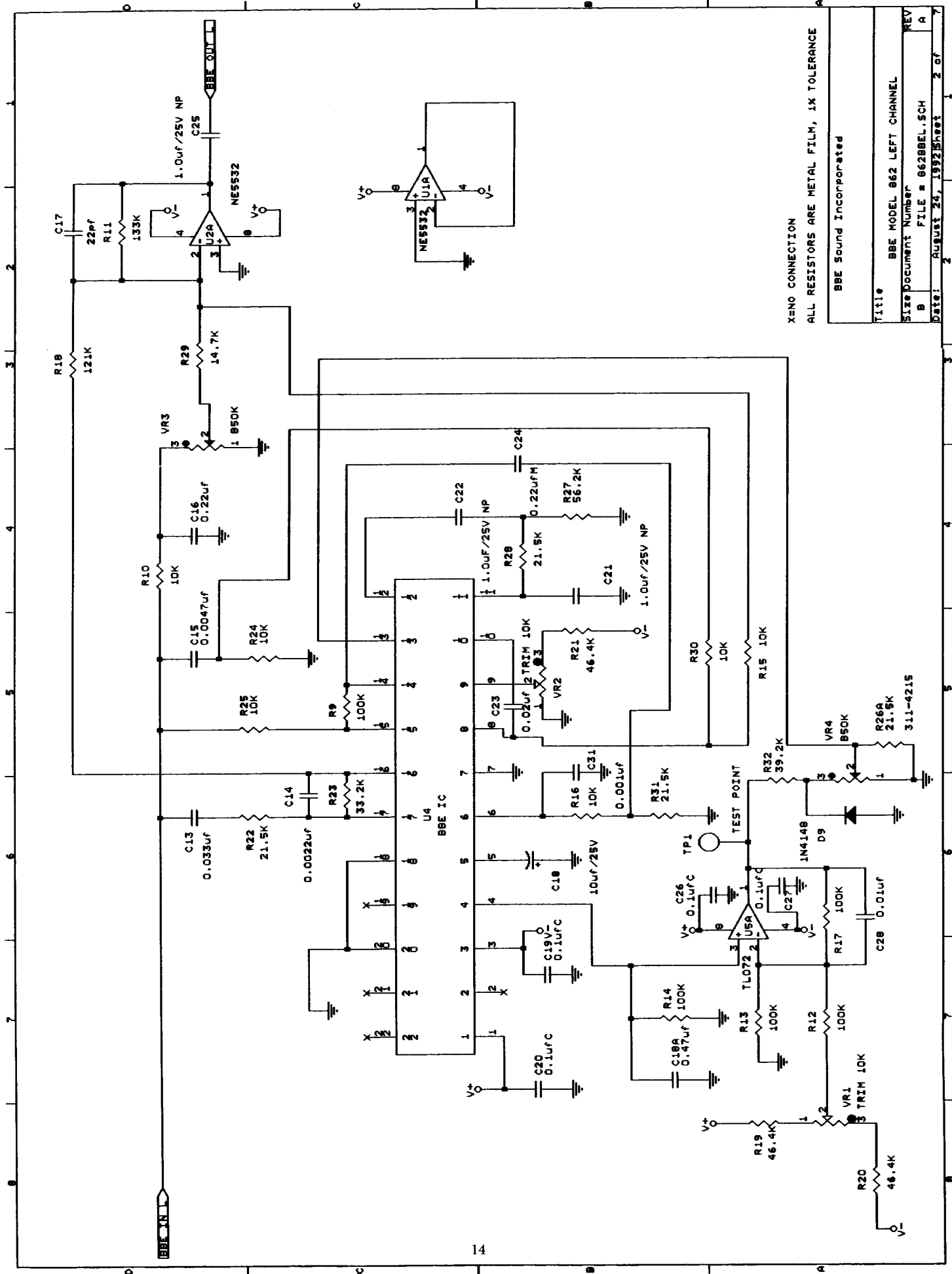

X=NO CONNECTION
 ALL RESISTORS ARE METAL FILM, 1% TOLERANCE

BBE Sound Incorporated

Title
 BBE MODEL 862 LEFT CHANNEL

Size Document Number
 B

File # 862BBEL.SCH

Date: August 24, 1992 Sheet 2 of 7

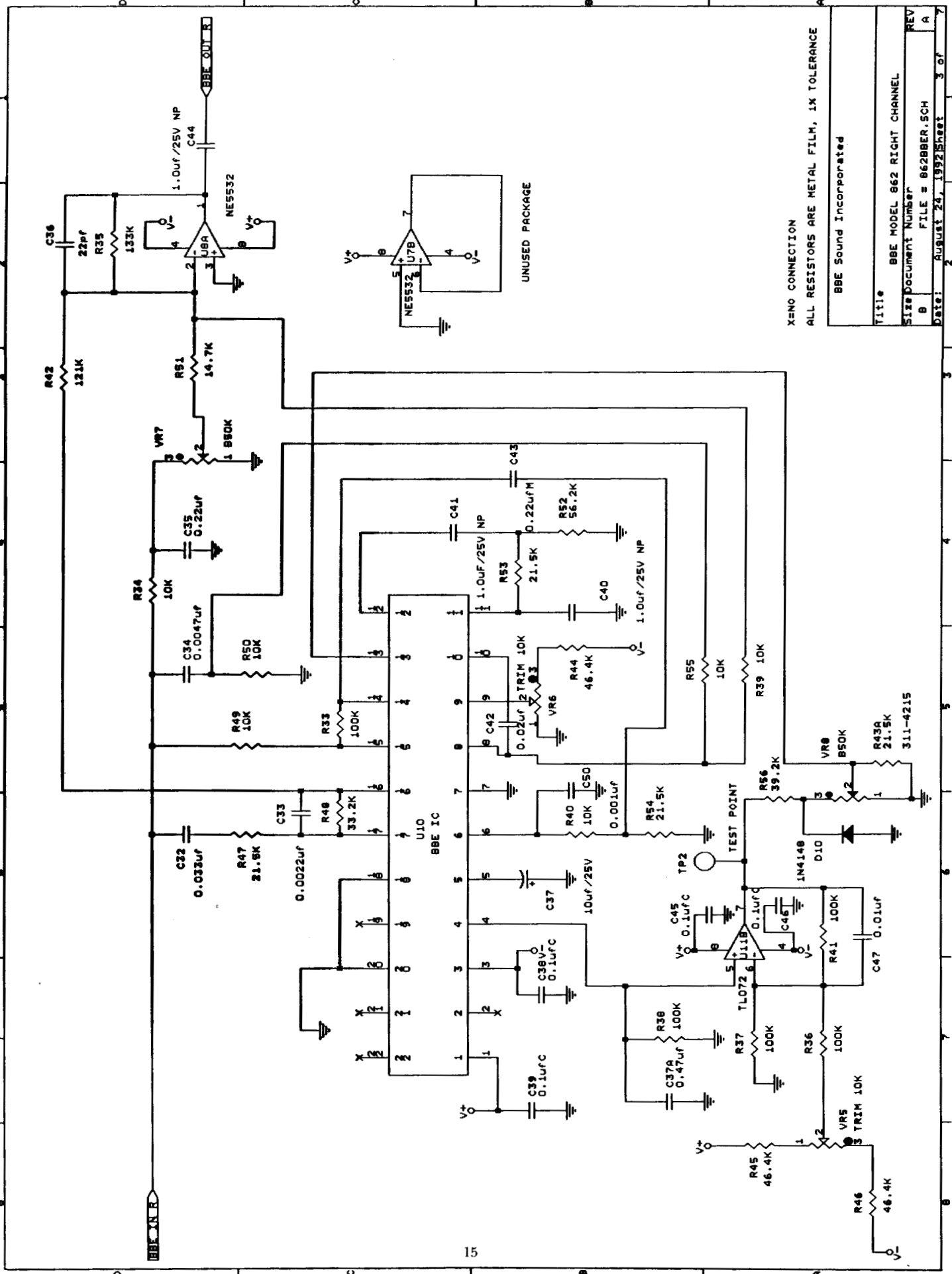

X=NO CONNECTION
 ALL RESISTORS ARE METAL FILM, 1% TOLERANCE
 BBE Sound Incorporated

Title	BBE MODEL 662 RIGHT CHANNEL
Size Document Number	B
File	862BBER.SCH
REV	A
Date	AUGUST 24, 1992
Sheet	3 of 7

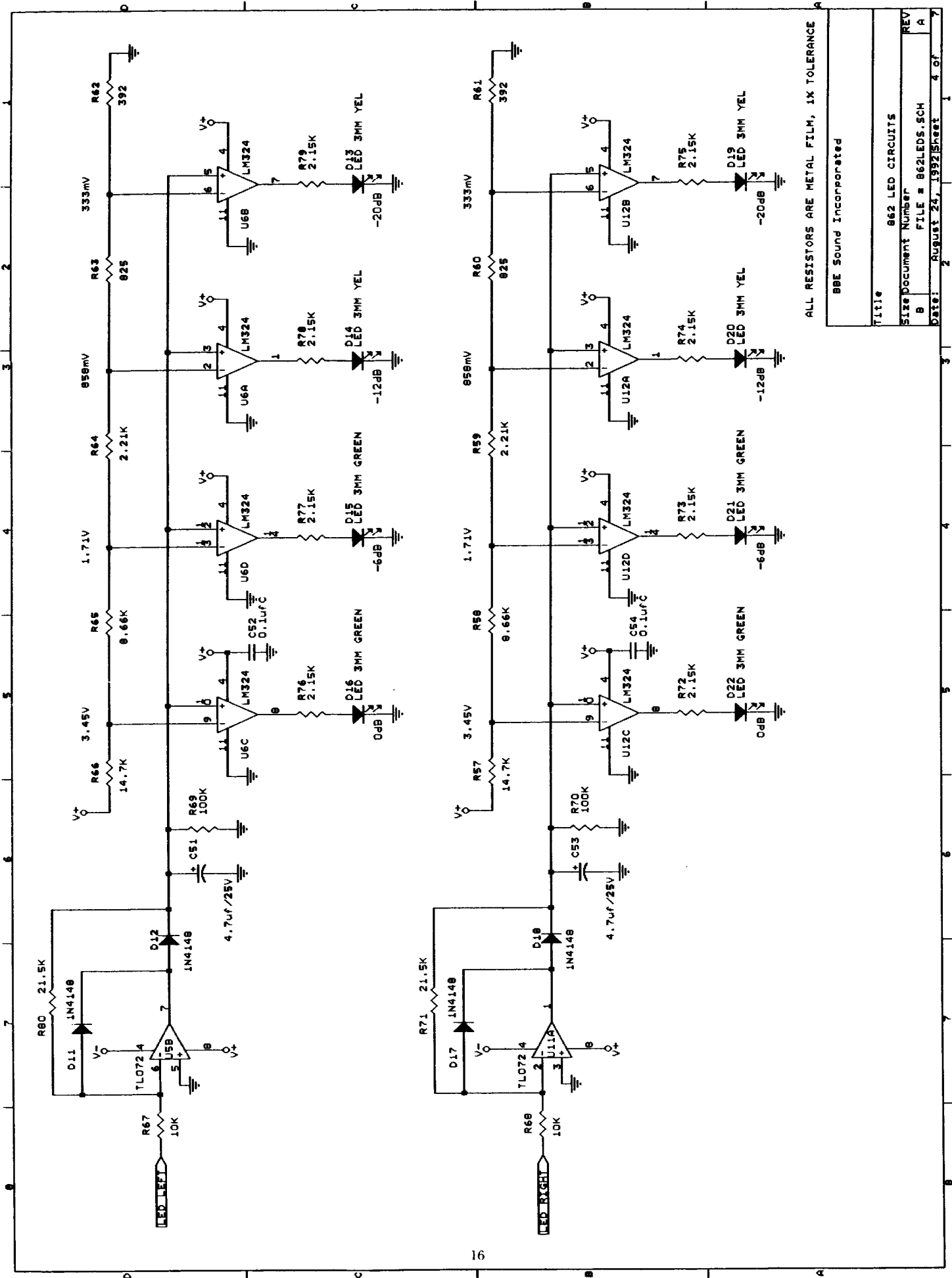

ALL RESISTORS ARE METAL FILM, 1% TOLERANCE

BBE Sound Incorporated	
Title	
862 LED CIRCUITS	
Size	Document Number
B	FILE # 862LEDS.SCH
REV	A
Date:	AUGUST 24, 1992
Sheet	4 of 7

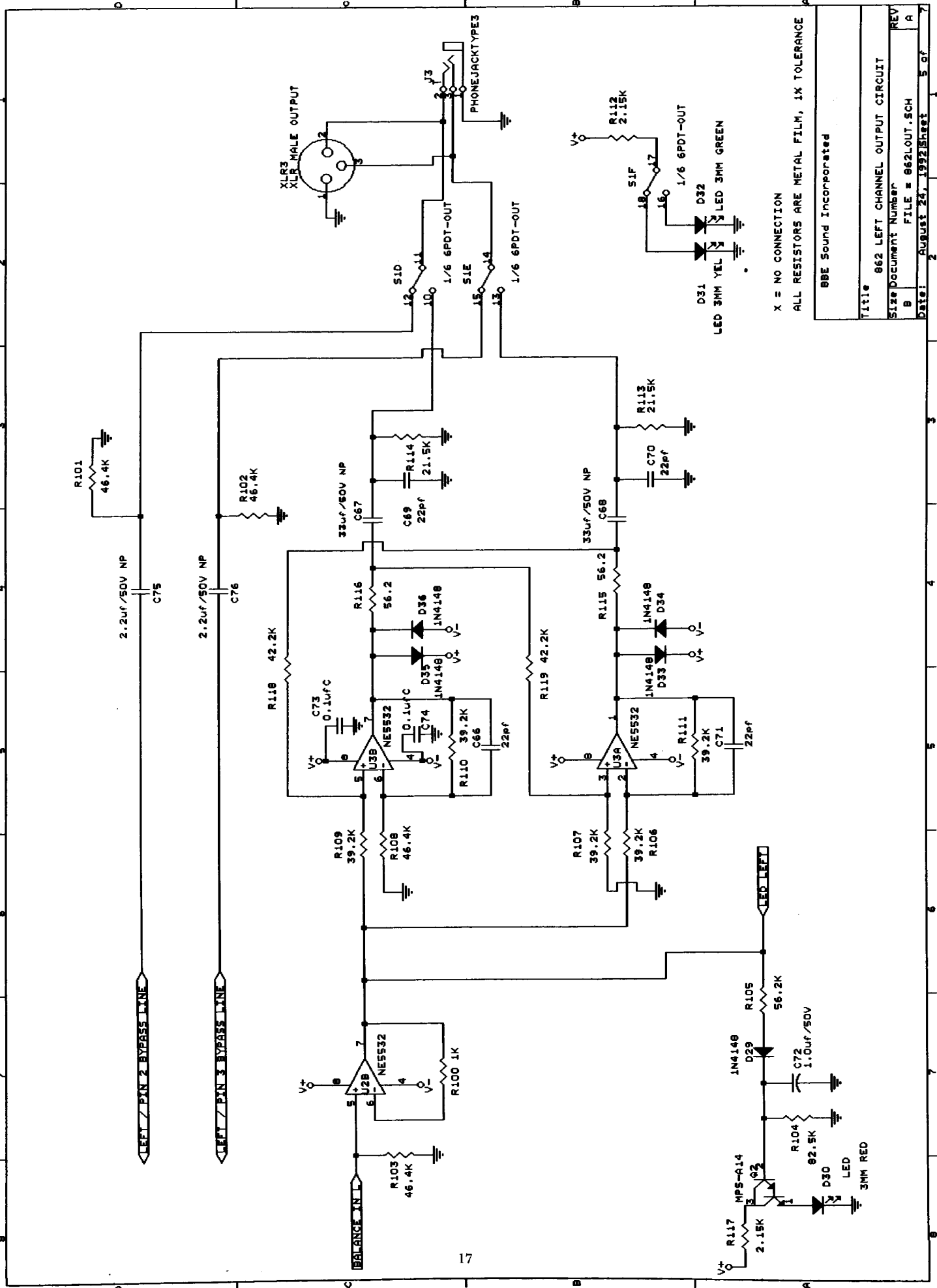

X = NO CONNECTION
 ALL RESISTORS ARE METAL FILM, 1% TOLERANCE

BBE Sound Incorporated

Title	862 LEFT CHANNEL OUTPUT CIRCUIT
Size Document Number	FILE = 862L.OUT.SCH
REV	A
DATE	AUGUST 24, 1992 Sheet 5 of 7

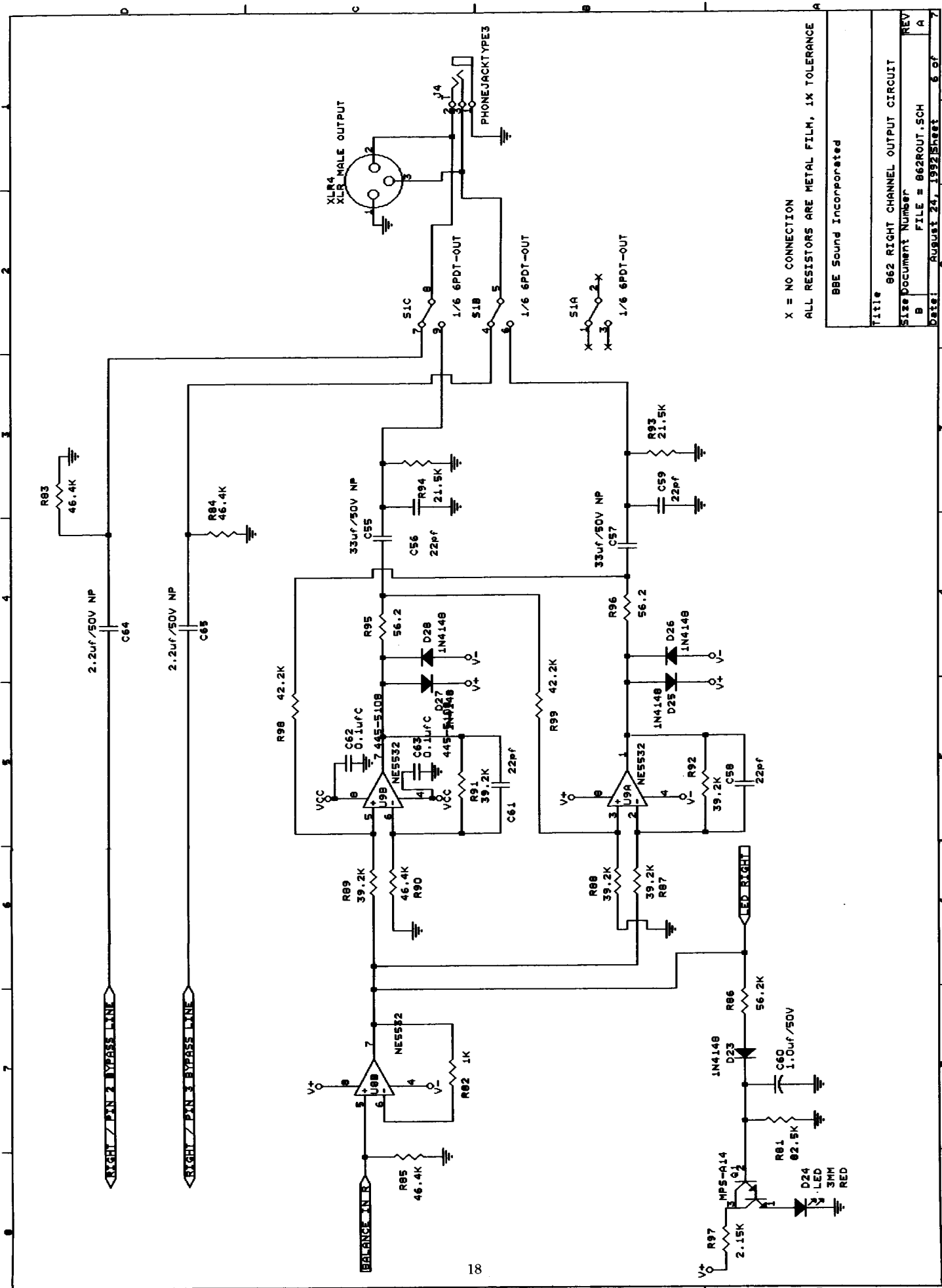

X = NO CONNECTION
 ALL RESISTORS ARE METAL FILM, 1% TOLERANCE

BBE Sound Incorporated

Title		662 RIGHT CHANNEL OUTPUT CIRCUIT
Size Document Number		REV
B	FILE =	662ROUT.SCH
Date:	AUGUST 24, 1992	Sheet 6 of 7

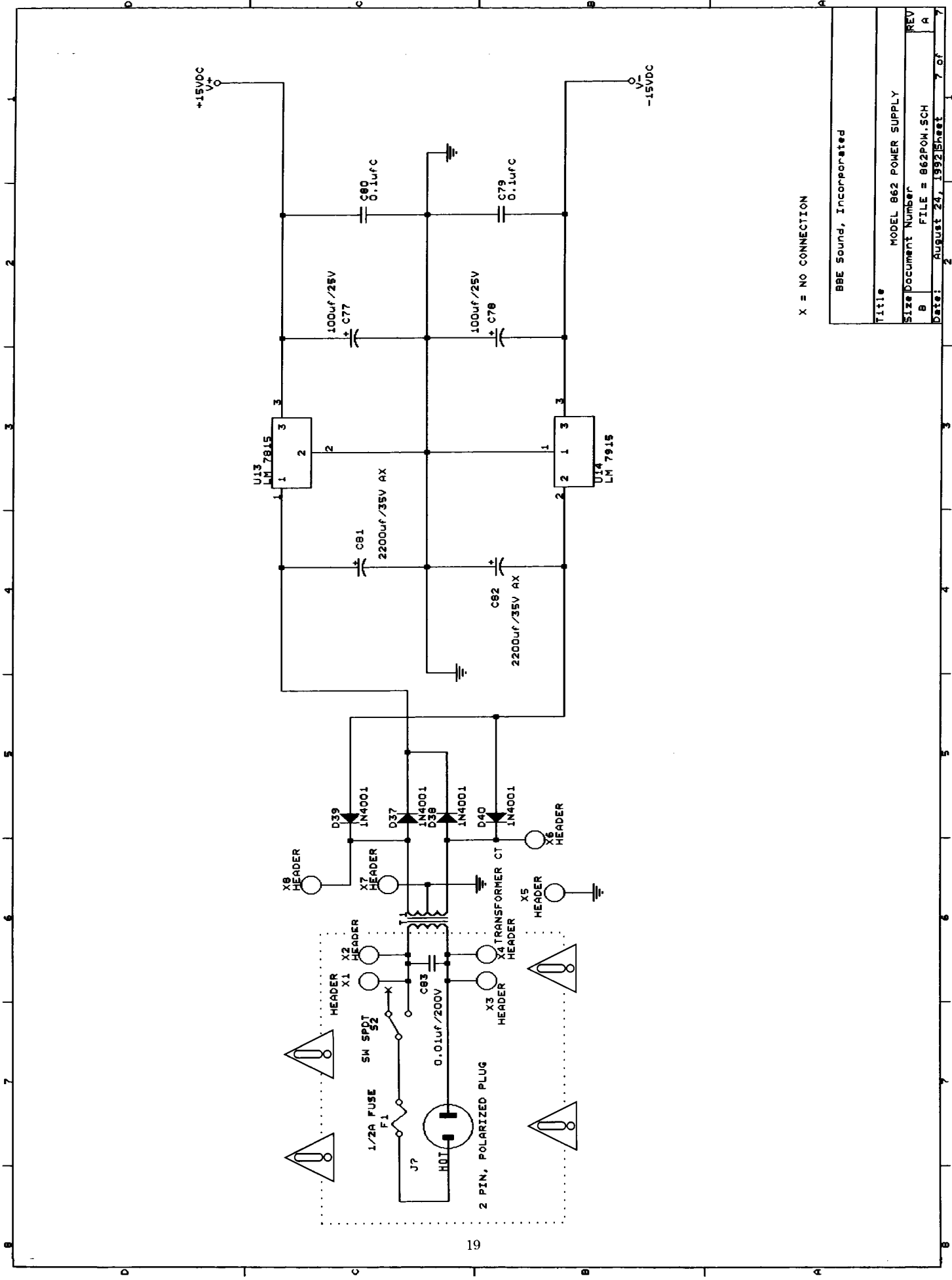

X = NO CONNECTION

BBE Sound, Incorporated	
Title	
MODEL 862 POWER SUPPLY	
Size	Document Number
B	FILE = 862POM.SCH
REV	A
Date:	August 24, 1992 Sheet 7 of 7



BBE[®]
Sound Inc.

CALIFORNIA, U.S.A.
(714)897-6766 * FAX(714)895-6728

BBE is a registered trademark of BBE Sound, Inc.

Covered by U.S. Patent 4,482,866 and other U.S. and foreign patents pending.
BBE is the registered trademark of BBE Sound, Inc.

Free Manuals Download Website

<http://myh66.com>

<http://usermanuals.us>

<http://www.somanuals.com>

<http://www.4manuals.cc>

<http://www.manual-lib.com>

<http://www.404manual.com>

<http://www.luxmanual.com>

<http://aubethermostatmanual.com>

Golf course search by state

<http://golfingnear.com>

Email search by domain

<http://emailbydomain.com>

Auto manuals search

<http://auto.somanuals.com>

TV manuals search

<http://tv.somanuals.com>