

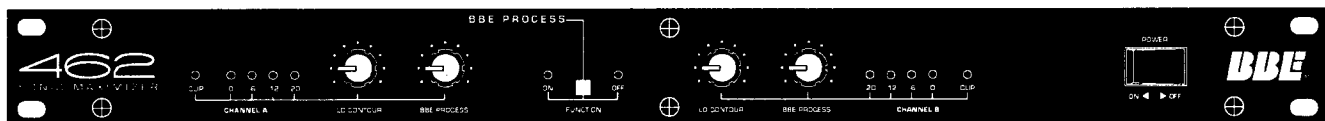

▲

MODEL 462
SONIC MAXIMIZER
USER MANUAL



Important Safeguards

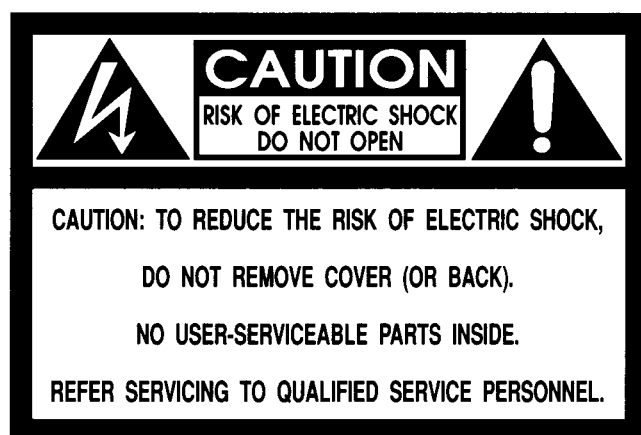

WARNING

To prevent fire or shock hazard, do not expose the unit to rain or moisture.

ATTENTION: RISQUE DE CHOC ELECTRIC- NE PAS OUVRIR.



The lightning flash with arrowhead symbol, within an equilateral triangle, is intended to alert the user to the presence of uninsulated "dangerous voltage" within the product's enclosure that may be of sufficient magnitude to constitute a risk of electric shock to persons.



The exclamation point, within a equilateral triangle is intended to alert the user to the presence of important operating and maintenance (servicing) instructions in the literature accompanying the appliance.

For your protection, please read these safety instructions completely before operating the appliance, and keep this manual for future reference.

Carefully observe all warnings, precautions and instructions on the appliance and described in the operating instructions supplied with the appliance.

INSTALLATION

Water and Moisture - Do not install the appliance near water: for example, near a bathtub, washbowl, kitchen sink, laundry tub, in a wet basement, or near a swimming pool.

Heat - Do not install the appliance near sources of heat such as radiators, heat registers, stoves, or other appliances that produce heat.

Ventilation - Situate the product so its location or position does not interfere with its proper ventilation. For example, you should not place the product on a bed, sofa, rug, or similar surface that might block the vent openings, or placed in a built-in installation, such as a bookcase or cabinet that might impede the flow of air through the ventilation openings.

Wall or Ceiling Mounting - If your appliance can be mounted to a wall or ceiling, mount it only as recommended.

USE

Power Source - Connect the appliance to a power supply only of the type described in the operating instructions or as marked on the appliance.

Power-Cord Protection - Route the power cord so that it is not likely to be walked on or pinched by having objects placed on it, paying particular attention to the plugs, receptacles, and the point where the cord exits from the appliance.

Grounding or Polarization - Do not defeat the grounding or polarization feature of the AC power cord. If your AC receptacle will not accept the power cord plug, contact your electrician to install a proper AC receptacle.

When not in use - Unplug the power cord of the appliance from the outlet when left unused for a long period of time. To disconnect the cord, pull it out by grasping the plug. Never pull the plug out by the cord.

AC Receptacle - Check to make sure that the AC receptacle holds the power cord plug firmly and securely. If the power cord plug is loose, contact your electrician to replace the defective and unsafe AC

Foreign Objects - Be careful that foreign objects and liquids do not enter the enclosure through openings.

SERVICE

Unplug the appliance from the wall outlet and consult qualified service personnel when:

- the power cord or the plug has been damaged.
- a solid object or liquid has fallen into the cabinet.

- the appliance has been exposed to rain or moisture.
- the appliance does not appear to operate normally or exhibits a marked change in performance.
- the appliance has been dropped, or the enclosure damaged.

Do not attempt to service the appliance beyond that described in the operating instructions. For all other servicing, refer to qualified service personnel **only**.

▲
TABLE OF CONTENTS

| | |
|--|-------|
| Precautions | I |
| Product Description | 1 |
| Controls/Connections | 2-4 |
| General Operation/Applications | 5-10 |
| Service/Warranty Information | 11 |
| Calibration | 12 |
| Specifications | 5 |
| Schematic Diagram | 13-17 |

Congratulations on your purchase of the **BBE 462 Sonic Maximizer**, an extremely versatile, two channel signal processor that will benefit any sound reproduction system. Program material will have sparkle and unmistakable clarity. Lower frequencies, such as a bass guitar, will be more evident in the mix. Voices will be crystal clear. Guitar and keyboard notes will have greater integrity and be more distinct from each other. If classical music is your forte, listen to your favorite symphony and feel as though you are the conductor. Rap music will take on new dimensions with a thunderous, yet tight thump which cannot be achieved with any other sound processor. The **BBE 462's** flexible design will allow it to be configured into any system. Whether live sound reproduction or in recording studios, the **BBE 462** will be a welcome addition.

The following features will make the **BBE 462** attractive to sound engineers, players and listeners:

1. Independent **PROCESS** and **LO CONTOUR** control for each channel to accommodate mono or stereo configurations.
2. A **Function Switch** to allow for the comparison of the BBE processed signal to the unprocessed signal.
3. Quarter inch **Phone** jacks and **RCA** connectors to allow for easy, unbalanced configuration into any sound system.
4. **Clip LED** to monitor the incoming signal level.
5. A four level LED indicator to monitor the output of the **BBE 462 Sonic Maximizer**.

IMPORTANT

Before you begin, please check the contents within this box to insure that included are:

1. The **BBE 462 Sonic Maximizer**.
2. Four **Rubber Feet** for "Table Mount" applications
3. The **BBE 462 User's manual**.

If any of these items are found to be damaged or missing, immediately contact the **BBE** dealer from whom the unit was purchased.

Before you begin, please read this manual. It will help you use the **BBE 462** more effectively and answer most of the common questions that our service department receives. But if you still have questions, please call our service department at (714) 897-6766.

▲ HOW THE BBE PROCESS WORKS

The BBE Process has been designed to make music programs more intelligible and life-like than normally achieved with existing audio systems. The BBE Process works dynamically by boosting the harmonic content of the music program, as determined by the signal input, and imparting a linear phase shift across the audio spectrum. The phase shift allows for a separation of the high, mid and low frequencies so that they do not arrive at the speaker network at precisely the same time. This prevents the higher frequencies from being smothered. (As the phase shift is minimal, 2 milliseconds, it is not perceived as a delay or echo.) The amount of harmonic amplification is variable as selected by the **PROCESS** knob, to achieve crisp, tight music program. The **LO CONTOUR** knob is a bass frequency adjustment. When turned clockwise, the **LO CONTOUR** will add power and warmth to the music program. If your musical tastes require the bass frequencies be reduced, turn the knob counter-clockwise.

Although the majority of the process is achieved with the higher frequencies of the music program, the BBE Process will make a significant difference with the entire program. For example: An "A" at 440Hz on a guitar is fundamentally the same note as an "A" at 440Hz on a piano. What allows a listener to identify the respective instruments is the harmonic content. By realigning the phase relationship and amplitude of the harmonic frequencies, the distinctive sound of a guitar, a piano, or any musical instrument, is much more evident.

▲ FRONT PANEL CONTROLS AND CONNECTIONS

NOTE: BOTH CHANNELS OF THE BBE 462 ARE INDEPENDENT FROM EACH OTHER AND MAY PROCESS A STEREO SIGNAL SOURCE OR TWO INDEPENDENT SIGNAL SOURCES. NO DAMAGE WILL BE INFLICTED TO THE BBE 462 IF ONLY ONE CHANNEL IS UTILIZED.

CHANNEL A

1. **LED DISPLAY:** The LED display is used to indicate the output signal level of the **BBE 462**. Each number on the front panel corresponds to the output signal level, measured in decibels. Example: The "0" indicates a 0dBu signal level, "-6" refers to -6dBu, and so on. Once an input signal level has been established, increasing the **BBE PROCESS** and **LO CONTOUR** will increase

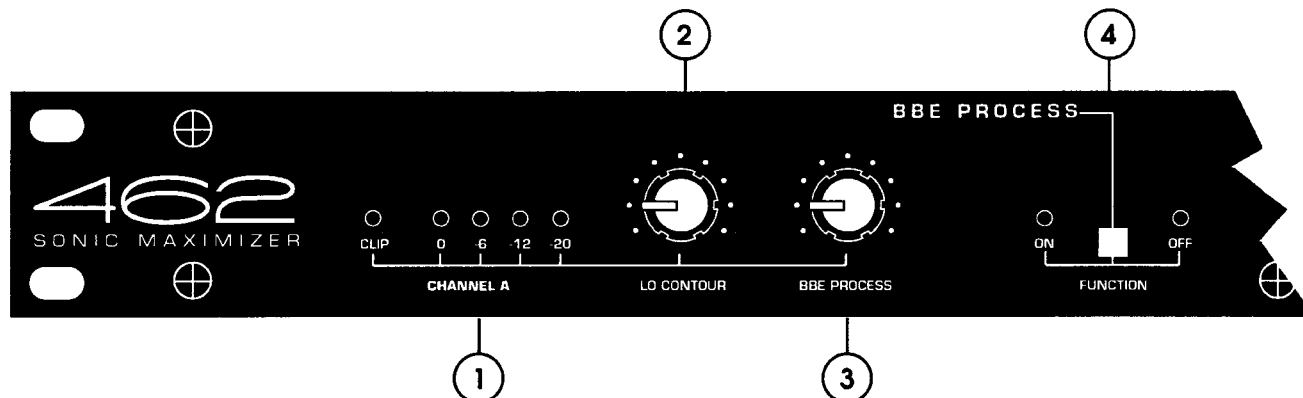

CHANNEL A cont.,

the output signal and cause more LEDs to illuminate. The **Clip LED** monitors the input signal level. The **Clip LED** will illuminate at +15dBu, giving a 3dBu warning of the impending distortion at +18dBu, the actual clip point.

2. **LO CONTOUR:** Each channel is equipped with a **LO CONTOUR** control. This control is a low frequency adjustment for the **BBE 462**. It provides a boost of 10dBu when turned to its maximum position (clockwise) at 50Hz. When turned to its minimum position, (counter-clockwise) it reduces the 50Hz signal by 10dBu. The middle position would be flat or no change.
3. **BBE PROCESS:** Each channel is equipped with a **BBE PROCESS** control. This control adjusts the BBE Process. The BBE Process gives the user a more detailed perception of tonality, added "bite" and an increase in clarity. The low frequency range of the program material will be tightened while the high end will be crystal clear without adding or creating any additional noise or harmonic distortion. When the knob is in its minimum position, completely counter-clockwise, no process is taking effect. Turning the knob clockwise will introduce the BBE Process. Adjust the knob to mix the desired amount of BBE Process to suit your taste. The BBE Process also has its own in/out switch for comparison of the processed to unprocessed signal located on the front panel. Experiment with the process. Use the BBE Process as an extension of the tone controls. The BBE Process is not an effect, but a sonic improvement. To start, set the **BBE PROCESS** knob to its 12 o'clock position, then adjust accordingly.
4. **FUNCTION:** This switch engages the BBE Process. When depressed, the "IN" position, the "GREEN" LED will illuminate, indicating that the BBE Process has been engaged. When in the "OUT" position, the "YELLOW" LED will illuminate, indicating that the BBE Process has been disengaged.
5. **CHANNEL B:** These controls function the same as the **CHANNEL A**.
6. **POWER:** This switch applies AC power to the **BBE 462 Sonic Maximizer**. When the **Power Switch** is in the "ON" position, either the "GREEN" or "YELLOW" **Function LED** will illuminate, as determined by the **Function Switch**, to indicate that power has been applied. When the **Power Switch** is not in the "ON" position, neither of the **Function LED s** will illuminate.

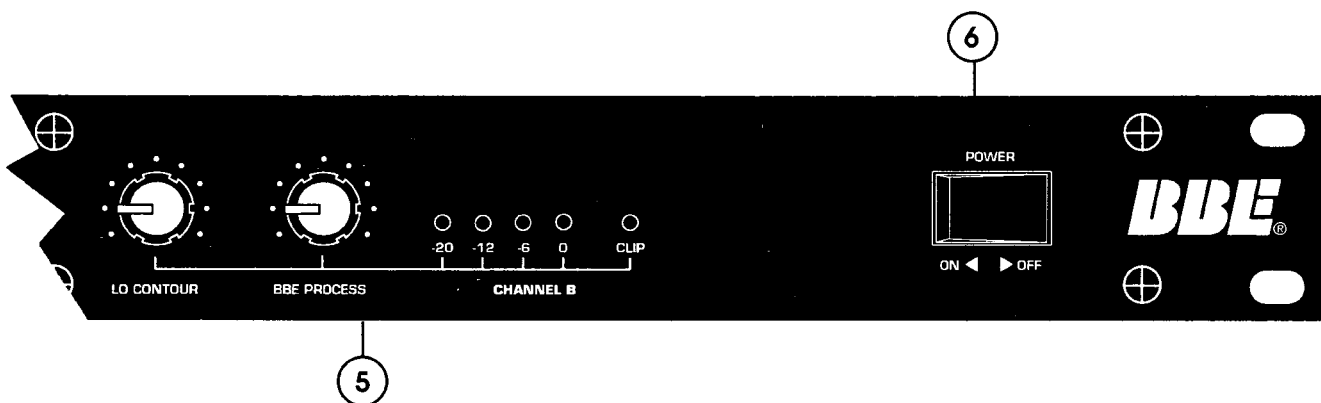

▲
REAR PANEL

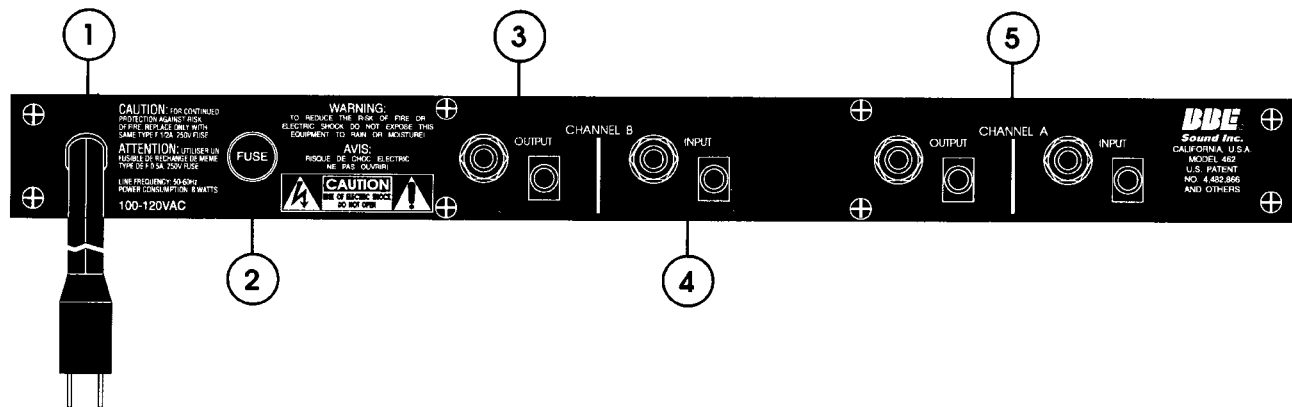

1. **POWER CORD:** U.S. Configuration: This is a standard two-pronged, polarized AC power cable for connection to any standard polarized 110Vac outlet. Plugs for other national configurations will vary.
2. **FUSE:** Replace **ONLY** with same type Fastblow fuse.
U.S., Canada and Japan models:
250Vac, 1/2A Fastblow
Standard model:
250Vac, .125A Fastblow

CHANNEL B

3. **OUTPUT:** The output of the **BBE 462** can be taken from the **1/4" Phone Jack** or the **RCA Jack**. Both are unbalanced and are the same point electronically. This allows both outputs to be used simultaneously, eliminating the need for a "Y" cord in the event multiple outputs are required. The recommended single load impedance is at least 10k Ohms. If both outputs are being used, a minimum of a 22k Ohm load per device is required. (The "load" is determined by the input impedance of the next subsequent component in the signal chain.) The maximum output is rated at +18dBu. The output impedance of the **BBE 462** is 1k ohms. **NOTE: Actual output level will vary due to the selected position of the BBE Process, and the actual input signal level.**
4. **INPUT:** The input of the **BBE 462** is an unbalanced connection. Although it can be either a **1/4" Phone Plug** or an **RCA Plug**, it is recommended that only one input source is used. Both jacks are the same point electronically, however, due to the input/output impedance characteristics of most audio devices, a loss of signal may occur and/or damage to a component if both inputs are utilized. The input impedance of the **BBE 462** is 47k Ohms. The maximum signal input level is +18dBu.
5. **CHANNEL A:** These controls function the same as the **CHANNEL B**.



SPECIFICATIONS

Frequency Response,

process mode: Program controlled

bypass mode: 20Hz to 20kHz, +/- 0.5dBu, -10dBu input

Noise: -90dBu

THD, process mode: less than 0.025% at -10dBu input, 20-20kHz

bypass mode: less than 0.002% at -10dBu input, 20-20kHz

Maximum Output: +18dBu (may vary due to control settings)

Input Impedance: 47k Ohms, unbalanced 1/4" phone jack or RCA jack

Output Impedance: 1k Ohms, unbalanced 1/4" phone jack or RCA jack

Sensitivity: -45dBu for maximum process

Maximum Process: +10dBu boost at 5kHz, -10dBu input

Lo Contour: +10/-10dBu adjustment at 50Hz, -10dBu input

* 0dBu = 0.775mVrms

Power Requirements: U.S., Canada & Japan models: 120VAC, 50/60Hz, 8 WATTS

Standard model: 220VAC, 50/60Hz, 8 WATTS

Fuse: Replace with the same type FASTBLOW fuse

U.S., Canada & Japan models: 250Vac, 1/2A Fast blow type fuse.

Standard model: 250Vac, .125A Fastblow type fuse

Dimensions: 19"(W) x 5.5"(D) x 1.7"(H)

Shipping Weight: 6.5lbs.

Note: Due to continuing product improvement, specifications and design are subject to change without notice.



GENERAL OPERATION

THE BBE 462 IS A LINE LEVEL SIGNAL PROCESSOR AND IS TO BE CONNECTED PRIOR TO THE POWER AMP IN ANY AUDIO SYSTEM. SIGNIFICANT DAMAGE MAY BE INFLICTED TO THE BBE 462 OR ANY SUBSEQUENT COMPONENT IN THE SYSTEM IN THE EVENT THE OUTPUT OF A POWER AMP IS CONNECTED DIRECTLY TO THE BBE 462.

In order to reduce the risk of damage to any equipment, properly connect all cables and power cables before turning on any components in the system. Most important of all, **ALWAYS TURN ON THE POWER AMPLIFIER LAST TO AVOID DAMAGING THE SPEAKERS OR THE AMP.**

The **BBE 462** may be utilized in a number of different environments and its results may vary accordingly. Because both channels are completely independent from each other, only one channel of the **BBE 462** may be used, or each channel processing a different signal source. The effects loop is the ideal placement in the signal chain of a guitar application. In a pre-amp, keyboard or P.A. application, the **BBE 462** works best as the last component in the signal chain, just before the crossover or power amp. **Important: In a P.A. application, never connect the BBE 462 into the effects loop. The inherent phase shift of the BBE Process will cause phase cancellation resulting in a partial loss of signal.**

BBE AND EQUALIZATION

The most common question asked of the BBE Sound, Inc. service department is: "Where does the BBE Processor connect in the signal chain, before or after the equalizer?" Many people find that the same amount of equalization is no longer needed, if at all, when a BBE processor is used. Additionally, the amount of equalization used will help determine the **BBE 462's** proper location in the signal chain: If the EQ is being set to give the room a flat response as determined by a spectrum analyzer, the **BBE 462** will work properly before or after the EQ. (Placing the **BBE 462** after the EQ is recommended.) If the EQ is being used for drastic tone alteration, the recommended placement would be before the EQ. Neither of these configurations will harm the **BBE 462**.

When the **BBE 462** is being used in a single instrument application, guitar, keyboards, etc., it may be advantageous to experiment with the proper placement of the BBE in the signal chain. The **BBE 462** will improve the sonic quality of the instrument and any effects that may be present as well. **Important: Generally, reverb and delay do not affect the BBE negatively. However, it is possible that with a large amount of effects added to an instrument that the BBE may process irregularly. If this occurs, reconnect the BBE 462 as the first item in the processor chain.**

Use the following illustrations as a starting point for proper placement of the **BBE 462**.

▲
LIVE APPLICATION: NON POWERED MIXER

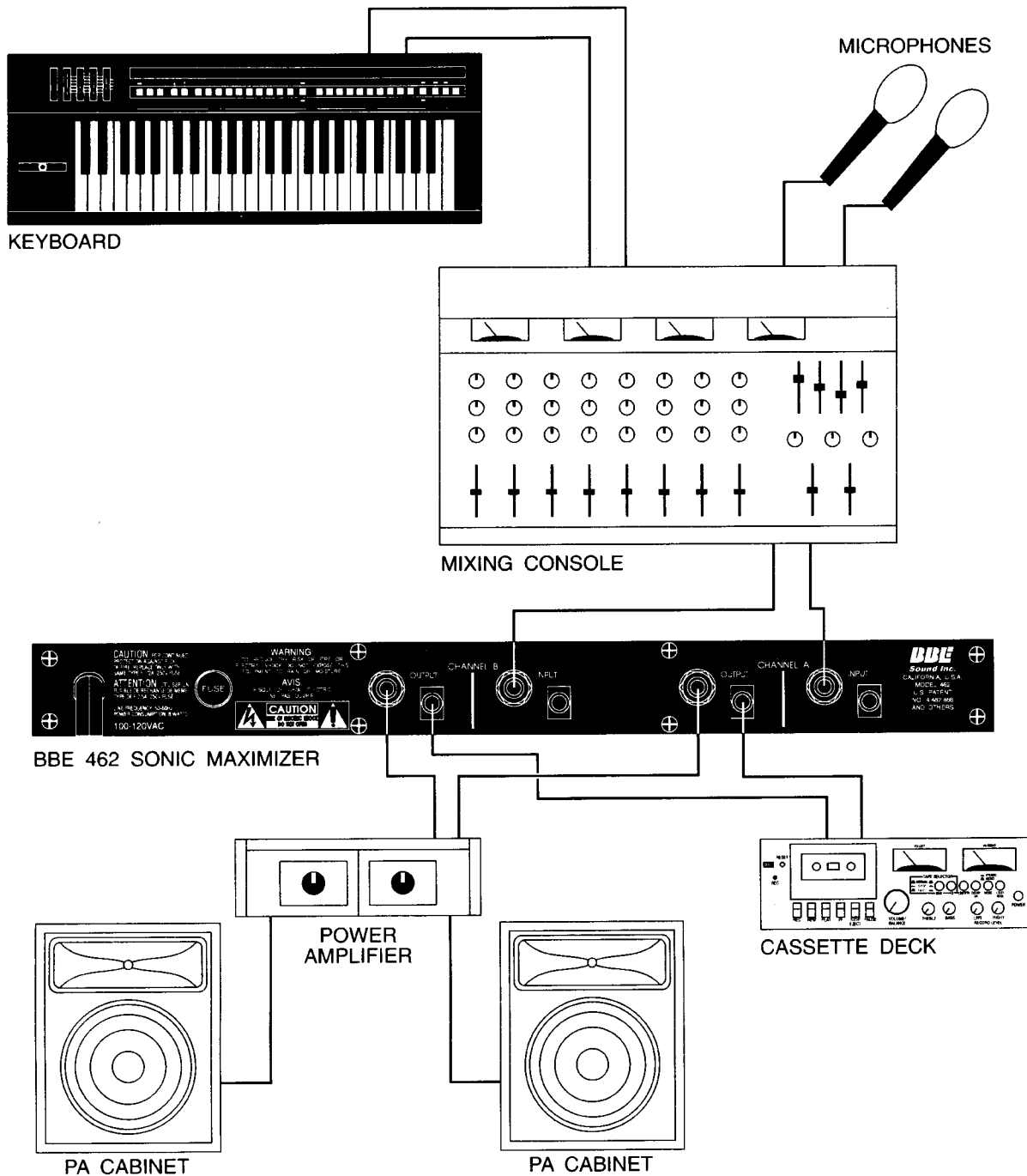

Connect the **BBE 462** to the output of the mixing console. The output of the **BBE** will drive either a crossover or a power amp directly. (If an equalizer is being used, refer to "**BBE AND EQUALIZATION**" section under "**GENERAL OPERATION.**")

LIVE APPLICATION: POWERED MIXER

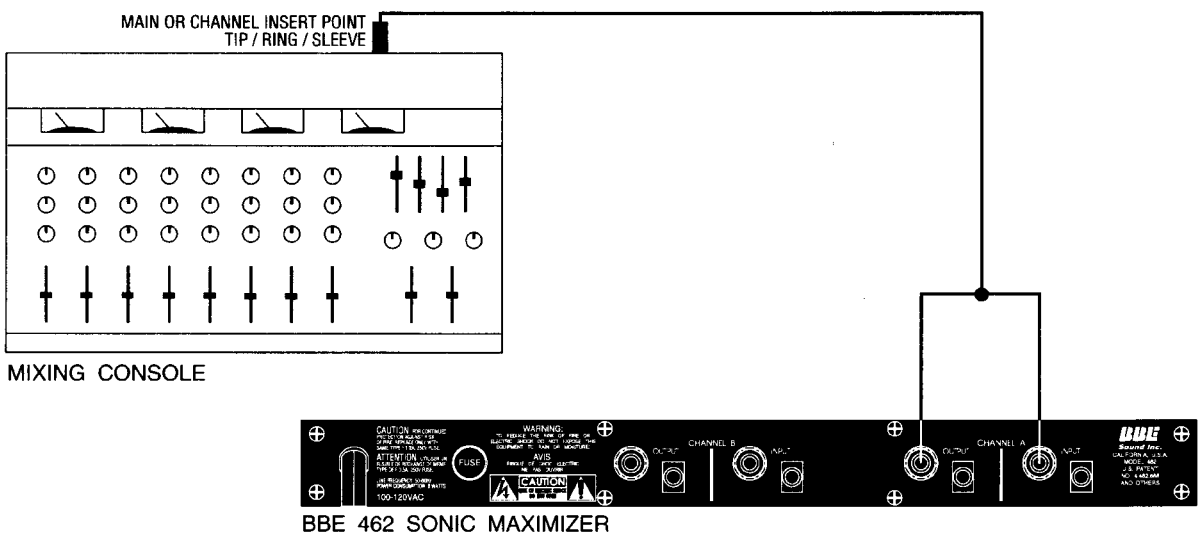
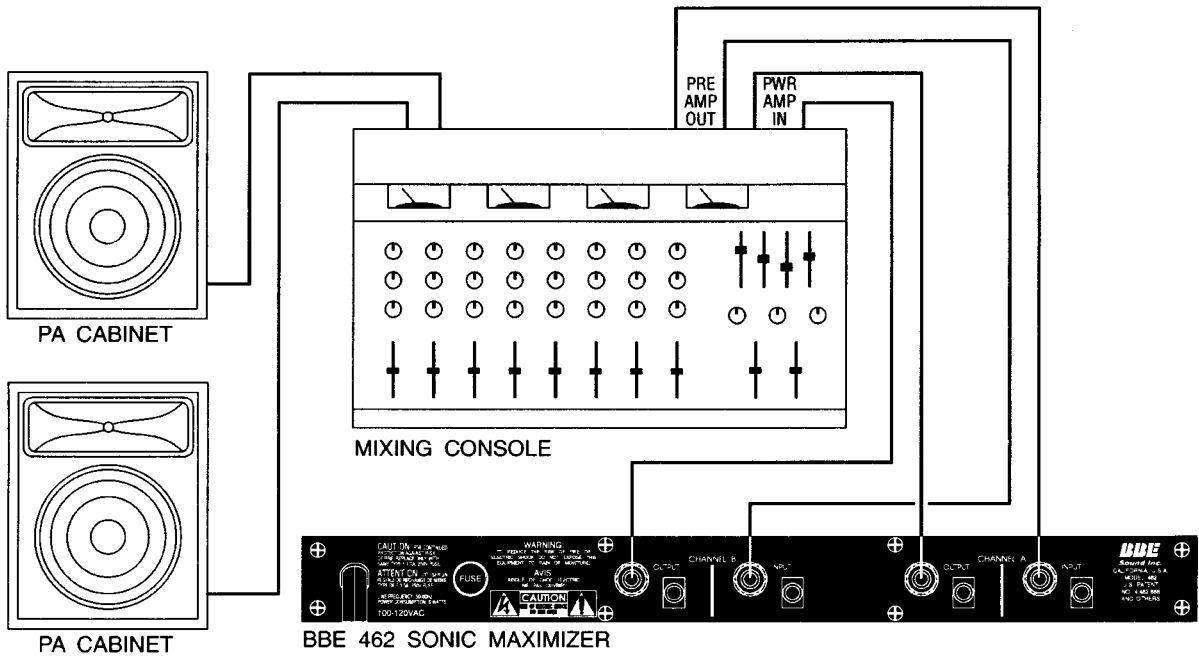

There are a couple of ways to configure the **BBE 462** into a powered mixer. The ideal method would be into "Pre-Amp Out / Power Amp In" section of the console. If your console does not have this option, use the main or channel insertion points.

▲ RECORDING

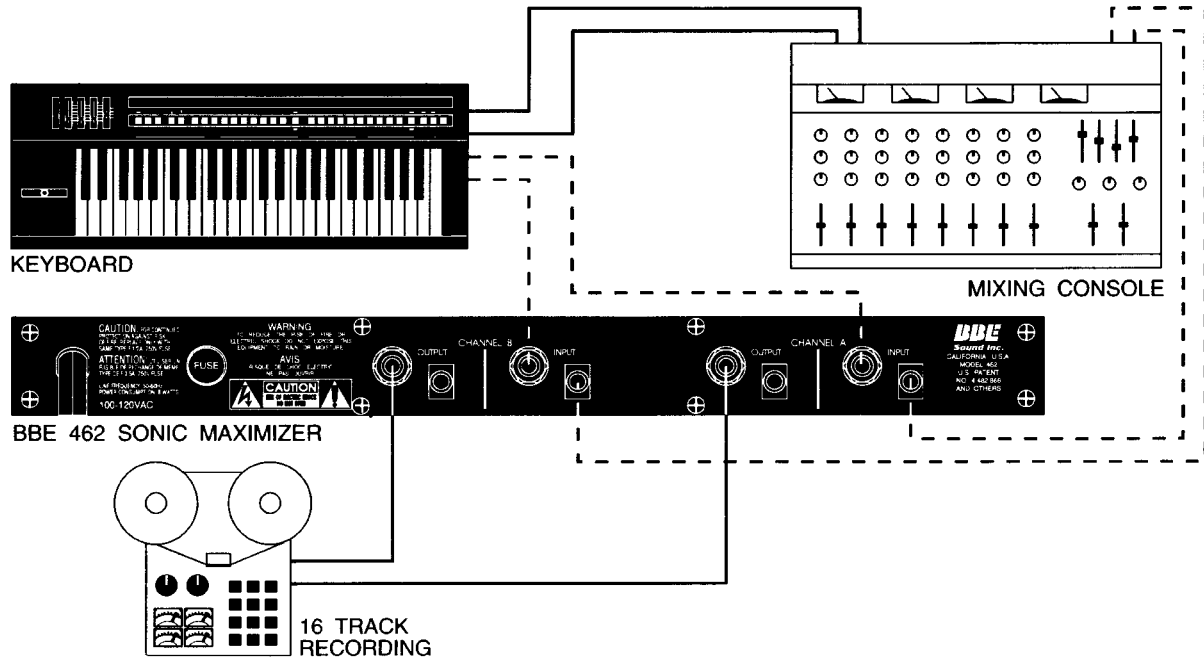

The **BBE 462** can be utilized in the recording studio on individual instruments or on groups of instruments to improve the sound quality.

▲ MASTERING OR DUBBING

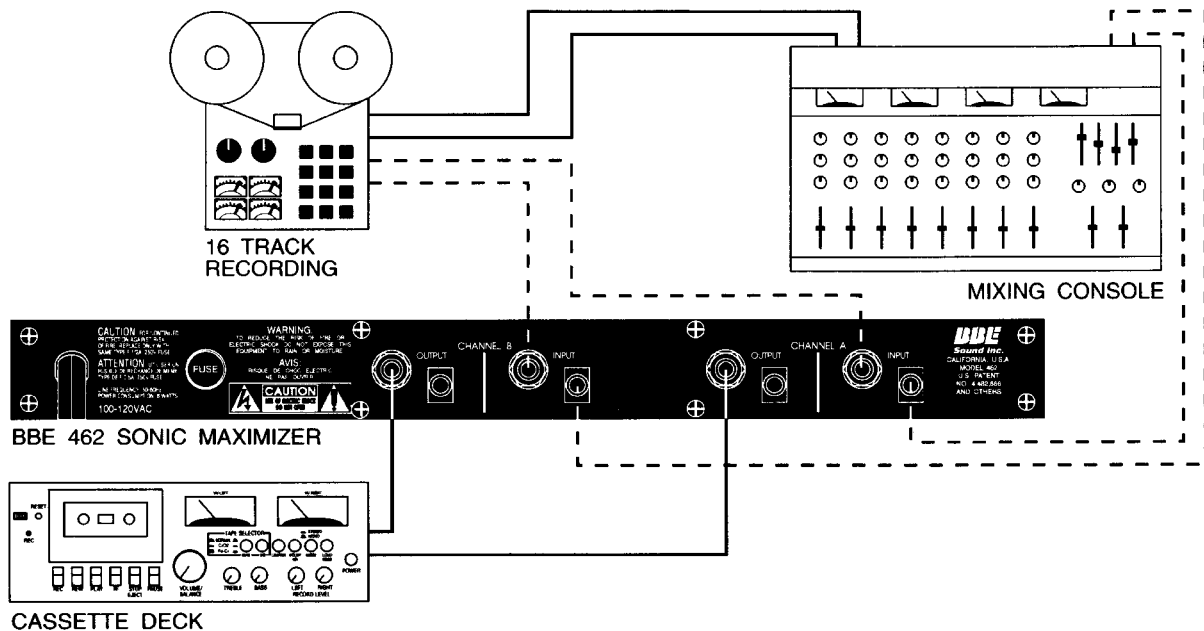

Use the **BBE 462** for mastering the recording. Even if the BBE Process has been used on individual tracks, an improvement of the total mix will be noticed.

INDIVIDUAL INSTRUMENTS

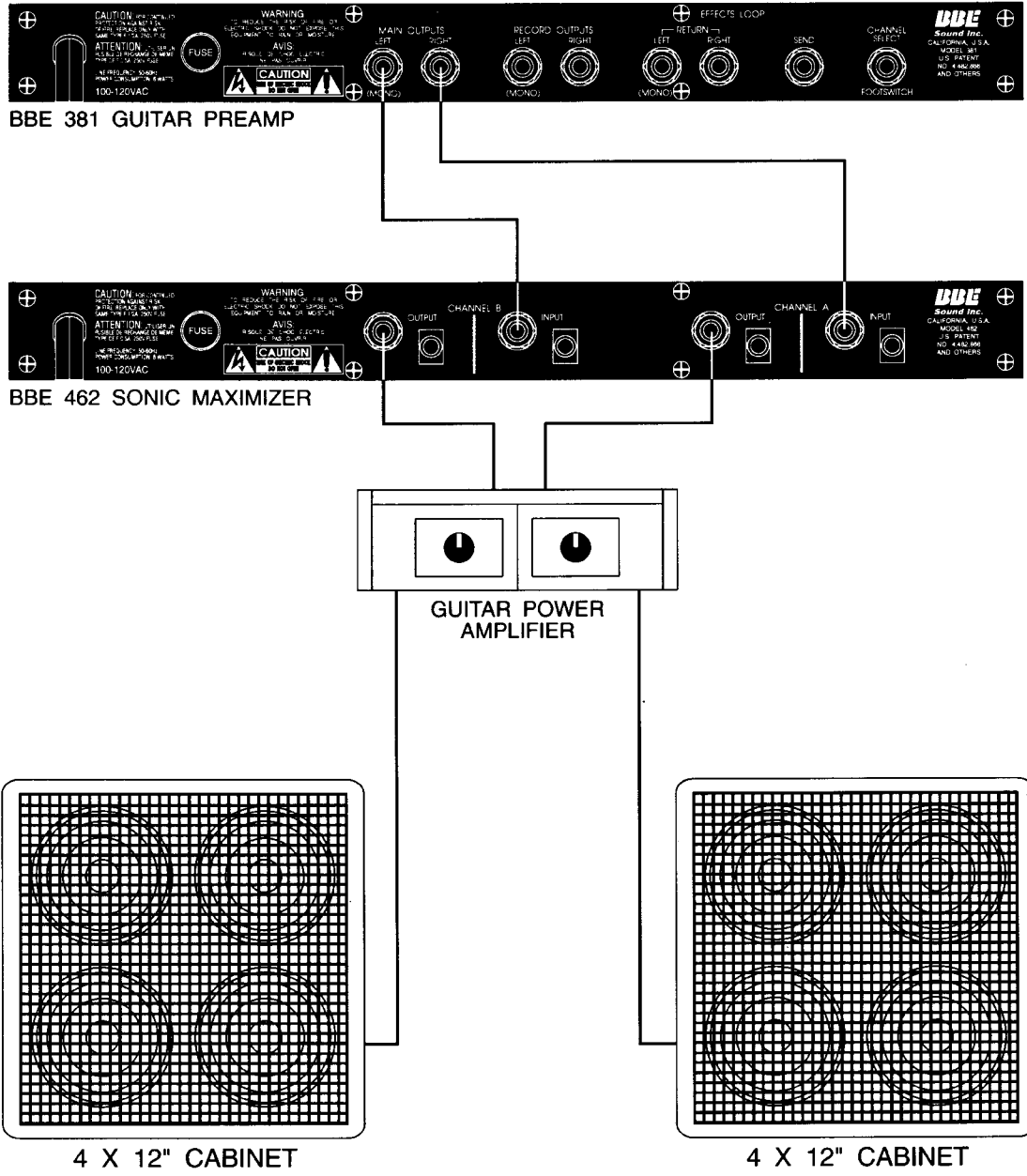

Use the **BBE 462** in effects loop or the main output of a guitar pre-amp. For keyboards, the output of the sub-mixer will be the ideal location.

▲ SOUND CONTRACTORS

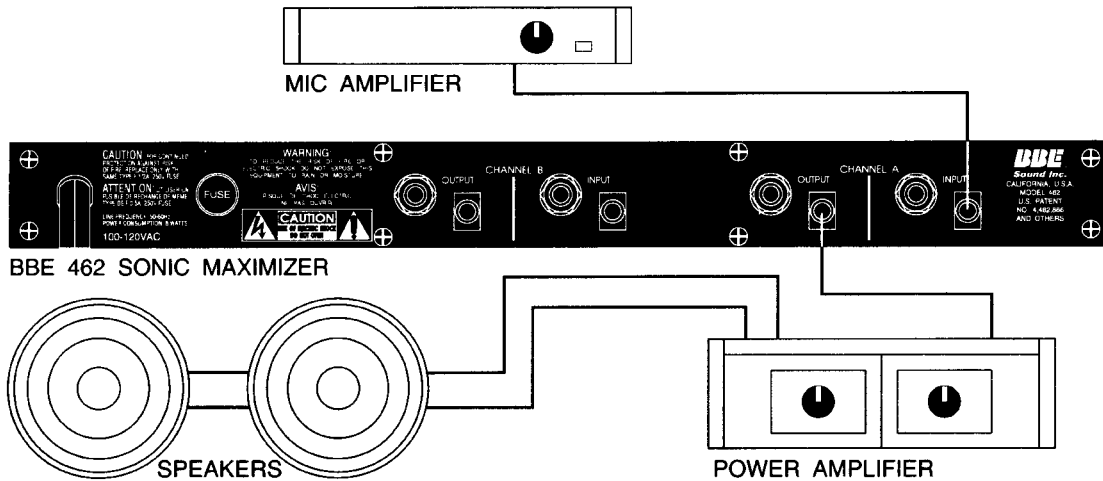

The **BBE 462** will accept the output level of most sound contractor type mixers.

▲ D.J. APPLICATION

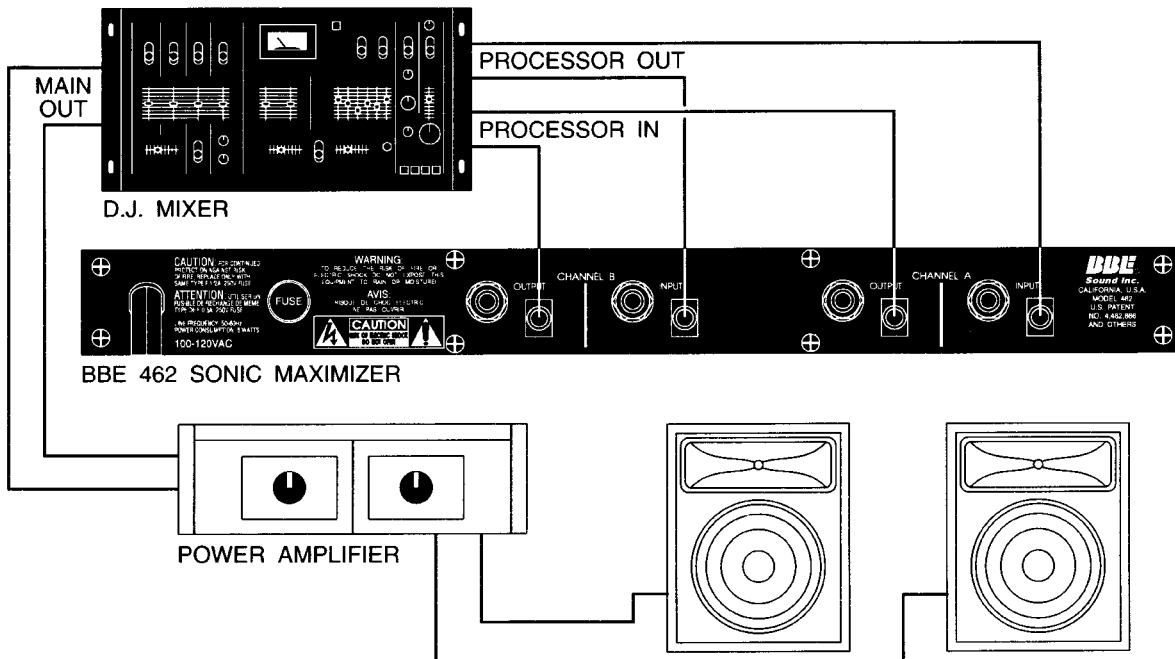

Connect the **BBE 462** into the processor loop of a pre-amp/mixer and hear the music come alive!



SERVICE

We recommend that if at all possible a **BBE 462 Sonic Maximizer** which requires service be sent to our facility in Huntington Beach, CA. We request that a "RETURN AUTHORIZATION" be issued by the dealer from whom you purchased the unit. If this is not possible, call BBE Sound, Inc. directly at (714) 897-6766, to obtain a "RETURN AUTHORIZATION." Include a copy of the bill of sale with the unit when it is shipped to BBE Sound Inc., so that the service process can be expedited.

As the repair turnaround time is minimal, we request that the unit be sent directly to BBE Sound, Inc. This helps us add reliability data to our files for use in designing future products.



MAINTENANCE

Maintenance of the **BBE 462 Sonic Maximizer** is limited to proper cleaning of the unit with a mild household cleaner such as Formula 409tm or Windextm. The chassis and cover are steel finished with a durable polyurethane paint, while the front panel is an anodized aluminum extrusion.

There are no user replaceable parts and the unit should not be opened for any reason unless you are a qualified technician. Calibration should be performed if parts are replaced or if a performance check-out indicates a problem with calibration. Long term use has shown that over the life of the unit there is little or no drift of the components in the **BBE 462** which would cause a change in calibration. A conservative design philosophy has resulted in a piece of equipment which should give years of trouble-free service.



WARRANTY

Warranty registration of the unit to BBE Sound, Inc. is not necessary. However, It is strongly recommended that you retain a copy of the bill of sale for future reference.

IT IS THE SOLE RESPONSIBILITY OF THE END USER TO PROVIDE THE BILL OF SALE OR OTHER MEANS OF PROOF OF PURCHASE TO VALIDATE THE WARRANTY IF WARRANTY SERVICE IS REQUIRED.

The **BBE 462 Sonic Maximizer** is warranted against defects in material and workmanship for a period of five (5) years from date of purchase from BBE Sound Inc. or from an authorized dealer.

During this period, we will repair units free of charge providing that they are shipped prepaid to BBE Sound, Inc. 5381 Production Drive, Huntington Beach, CA 92649. We will pay return UPS shipping charges within the USA. All charges related to non-UPS shipping, including customs clearance, will be billed. The warranty will be honored for the longer of either 90 days from the date of any service or the remainder of the original 5 Year factory warranty.

This warranty will be consider null and void by BBE Sound, Inc. if any of the following is found:

1. The equipment has been physically damaged.
2. The equipment shows signs of abuse.
3. The equipment has been electrically damaged by improper connection or attempted repair by the customer or a third party.
4. The equipment has been modified without authorization.
5. The bill of sales indicates that the purchase date of the equipment is not within the warranty period.

All non-warranty repairs are warranted for a period of 90 days from the date of service.

BBE Sound, Inc. is NOT LIABLE FOR CONSEQUENTIAL DAMAGES. Should the unit fail to operate for any reason, our sole obligation is to repair it as described above.



CALIBRATION PROCEDURE FOR THE BBE 462

NOTE: THIS UNIT WAS CALIBRATED AT THE FACTORY. THIS PROCEDURE IS FOR QUALIFIED SERVICE PERSONNEL ONLY.

Equipment Required: Audio Signal Generator (sine wave)
Digital Voltmeter (DVM)

Revision A.1
July 28, 1992

This procedure details the calibration of channel A. Comments [in brackets] pertain to channel B. All tests are done with a signal level of -10dBu (245Vrms) unless otherwise noted. The signal will be input into the 1/4" connector marked INPUT. The DVM shall monitor the 1/4" connector of each corresponding channel marked OUTPUT.

INITIAL SETTINGS:

- 1) **BBE PROCESS** controls **VR4 [VR8]** to minimum.
- 2) Turn **VR1 [VR5]**, **VR2 [VR6]** and **VR3 [VR7]** to their middle positions.
- 3) **POWER** switch **ON** and **FUNCTION** switch **IN** (process on).

PROCEDURE:

OFFSET ADJUSTMENT:

- 1) The unit should be on and the voltage regulators should be warm to the touch.
- 2) With no signal present at the input (open,) measure **TP1 [TP2]** with the DVM set to DC volts.
- 3) Adjust **VR1 [VR5]** until DVM reads **0.00VDC**.

POWER SUPPLY TEST:

- 1) With DVM set to DC volts measure the positive end of **C59**. It should be less than **+30VDC**.
- 2) With DVM set to DC volts measure the negative end of **C60**. It should be less than **-30VDC**.
- 3) With DVM set to DC volts measure **pin-8 of U2**. You should read **+15VDC (+/- 0.5VDC)**.
- 4) With DVM set to DC volts measure **pin-4 of U2**. You should read **-15VDC (+/- 0.5VDC)**.

UNITY ADJUSTMENT: (Note: **VR4 [VR8]** to minimum)

- 1) Input a 5000Hz signal (@ -10dBu) into the connector marked **CHANNEL A [B] INPUT**.
- 2) Measure the connector marked **OUTPUT CHANNEL A [B]** with the DVM
- 3) Adjust **VR2 [VR6]** until the DVM reads **-10.5 dBu**.
- 4) Set generator to 500Hz (@ -10dBu).
- 5) The DVM should read **-10.5 (+/-0.5dBu)**.

LO CONTOUR TEST:

- 1) Input a 50Hz signal (@ -10dBu) into the connector marked **CHANNEL A [B] INPUT**.
- 2) Measure the connector marked **OUTPUT CHANNEL A [B]** with the DVM set to AC volts.
- 3) Turn the LO CONTOUR control completely clockwise (marked "+"). The DVM should read **+1dBu (+/- 1.0dBu)**
- 4) Turn the LO CONTOUR control completely counter-clockwise (marked "-"). The DVM should read **-22.5dBu (+/-1.0dBu)**
- 5) Turn the control to the middle position. The DVM should read approximately **-8.5dBu (+/- 1.0dBu)**.

DETECTOR CHECK: (Note: The **BBE PROCESS** control must be completely minimum)

- 1) Input a 500Hz signal @ -10dBu into the connector marked **CHANNEL A [B] INPUT**.
- 2) With DVM measure **TP1 [TP2]** you should read **-1.700VDC (+/-0.050VDC)**
- 3) Change the source to 500Hz, -35dBu. With DVM measure **TP1 [TP2]** you should read **-0.675VDC (+/- 0.050VDC)**
- 4) Turn the **BBE PROCESS** knob completely clockwise to maximum. The output should read **+1dBu (+/-1dBu)**.

BYPASS TEST:

- 1) Switch the **FUNCTION** switch **OUT** (bypass mode).
- 2) Input a 500Hz signal (@ -10dBu) into the connector marked **CHANNEL A [B] INPUT**.
- 3) Measure the connector marked **OUTPUT CHANNEL A [B]** with the DVM set to AC volts.
- 4) The DVM should read **-10dBu (+/-0.5dBu)**.

LED TEST:

- 1) Input a 5000Hz signal @ -20dBu (77.5mVrms) into the connector marked **CHANNEL A [B] INPUT**. The "YELLOW," -20 LED should light.
- 2) Change the input signal to -10dBu (245mVrms.) The "YELLOW," -12 LED should light.
- 3) Change the input signal to -5dBu (435mVrms.) The "GREEN," -6 LED should light.
- 4) Change the input signal to 0dBu (775mVrms.) The "GREEN," 0 LED should light.
- 5) With the **FUNCTION** switched to the **IN** position the corresponding "GREEN" LED should light.
- 6) With the **FUNCTION** switched to the **OUT** position the corresponding "YELLOW" LED should light.

CLIP INDICATOR TEST:

- 1) Input a 500Hz signal with an amplitude of **+15dBu (4.356Vrms)** into the connector marked **INPUT CHANNEL A [B]**. Insure the corresponding **CLIP LED** is fully lit for each channel.
- 2) Change the input signal level to **+14dBu (3.882Vrms.)** The **CLIP LED** should not be lit for each channel.

RCA CONNECTOR TEST:

- 1) Switch the **FUNCTION** switch **OUT** (bypass mode).
- 2) Input a 500Hz signal (@ -10dBu) into the RCA connector marked **CHANNEL A [B] INPUT**.
- 3) Measure the RCA connector marked **OUTPUT CHANNEL A [B]** with the DVM set to AC volts.
- 4) The DVM should read **-10dBu (+/-0.5dBu)**.
- 5) Return the **FUNCTION** switch to the **IN** position (process mode).

DC VOLTAGE AT OUTPUT TEST:

- 1) Measure the output jacks to ground with the DVM set to DC volts the voltage must be less than **10mVDC**.

OFFSET DRIFT TEST:

- 1) With no signal present at the input (open) measure **TP1 [TP2]** with the DVM set to DC volts.
- 2) Insure this voltage is **0.00VDC (+/- 25mVDC)**

END TEST

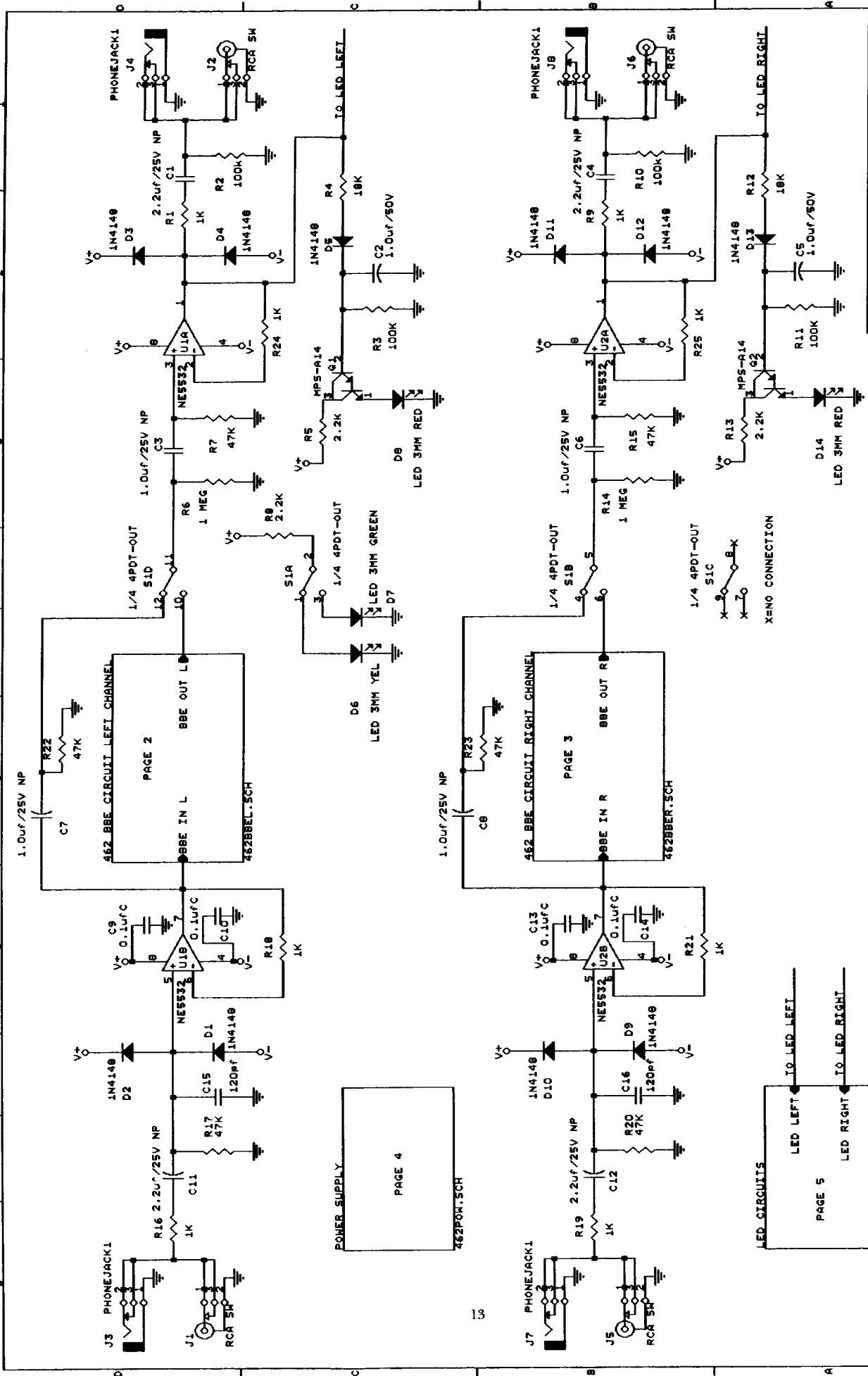

BBE 462 SONIC MAXIMIZER

| | |
|-------|-----------------|
| Size | Document Number |
| B | FILE = 462.sch |
| Date: | JULY 13, 1992 |
| Sheet | 1 of 5 |

BBE Sound Incorporated

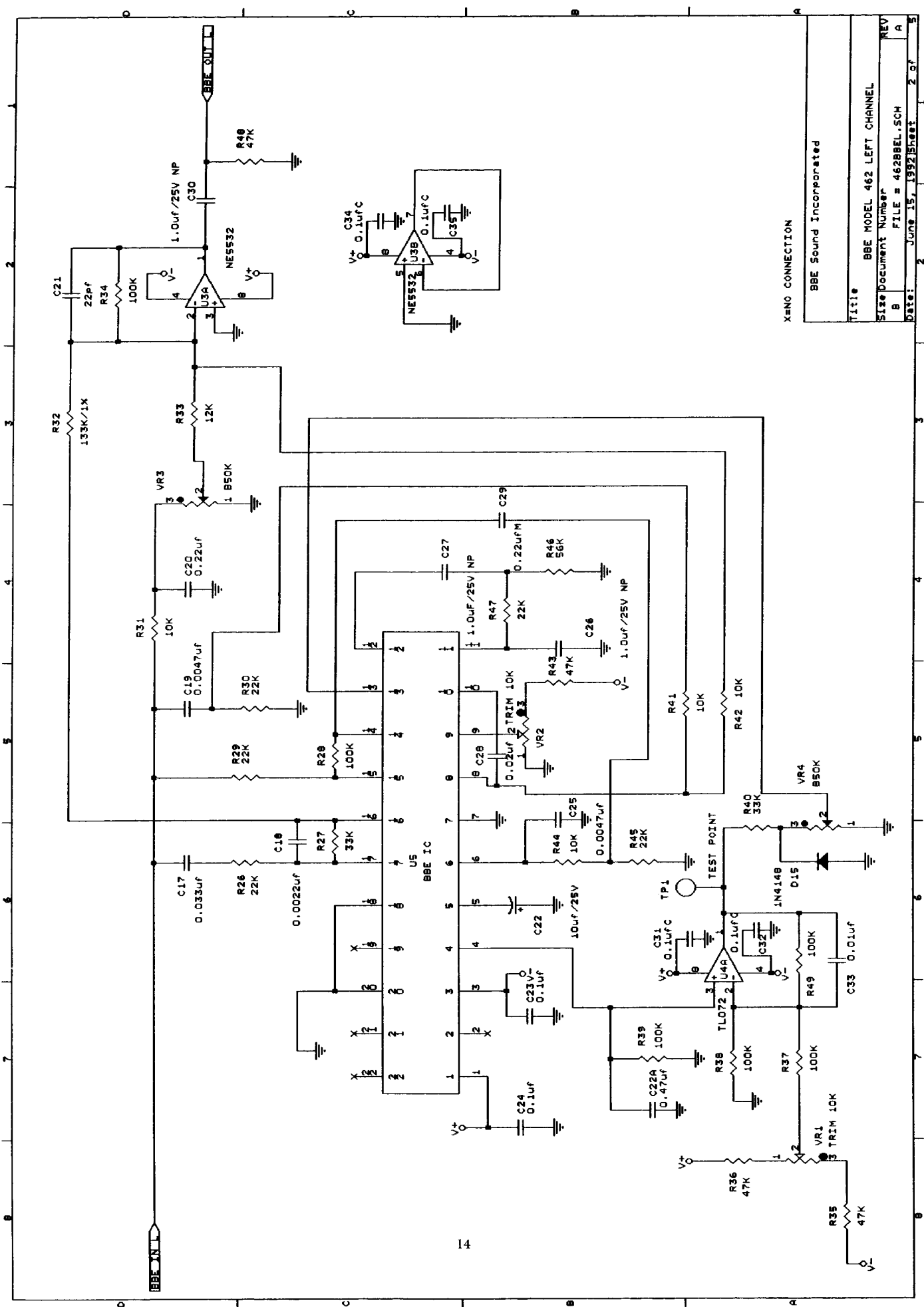

X=NO CONNECTION
BBE Sound Incorporated

| | |
|----------------------|----------------------------|
| Title | BBE MODEL 462 LEFT CHANNEL |
| Size Document Number | FILE = 462BBEL.SCH |
| REV | A |
| Date: | JUNE 15, 1992 Sheet 2 of 5 |

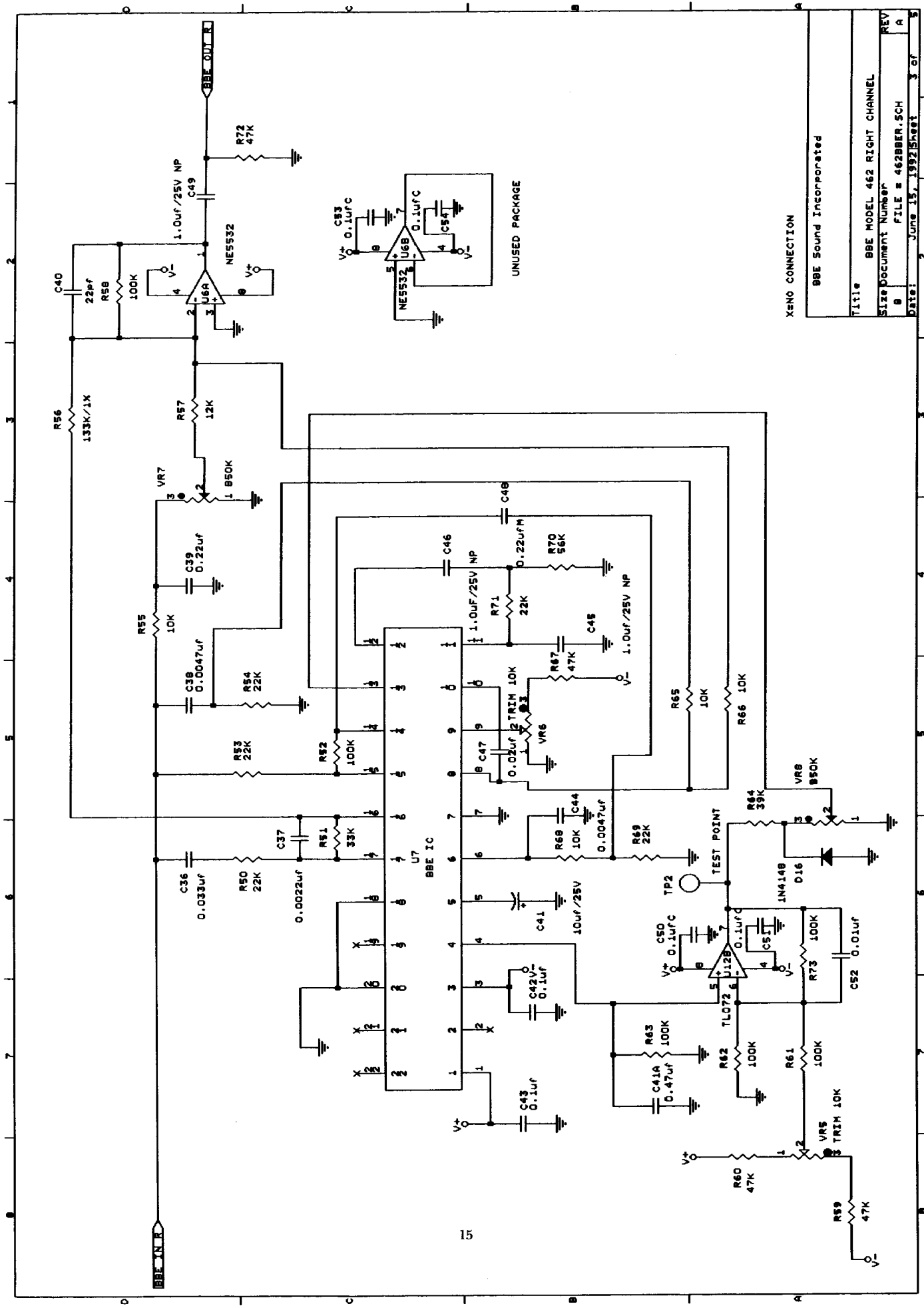

XENO CONNECTION

BBE Sound Incorporated

| | |
|-------|-----------------------------|
| Title | BBE MODEL 462 RIGHT CHANNEL |
| Size | Document Number |
| REV | FILE # 462BBER.SCH |
| Date: | June 15, 1992/Sheet 3 of 3 |

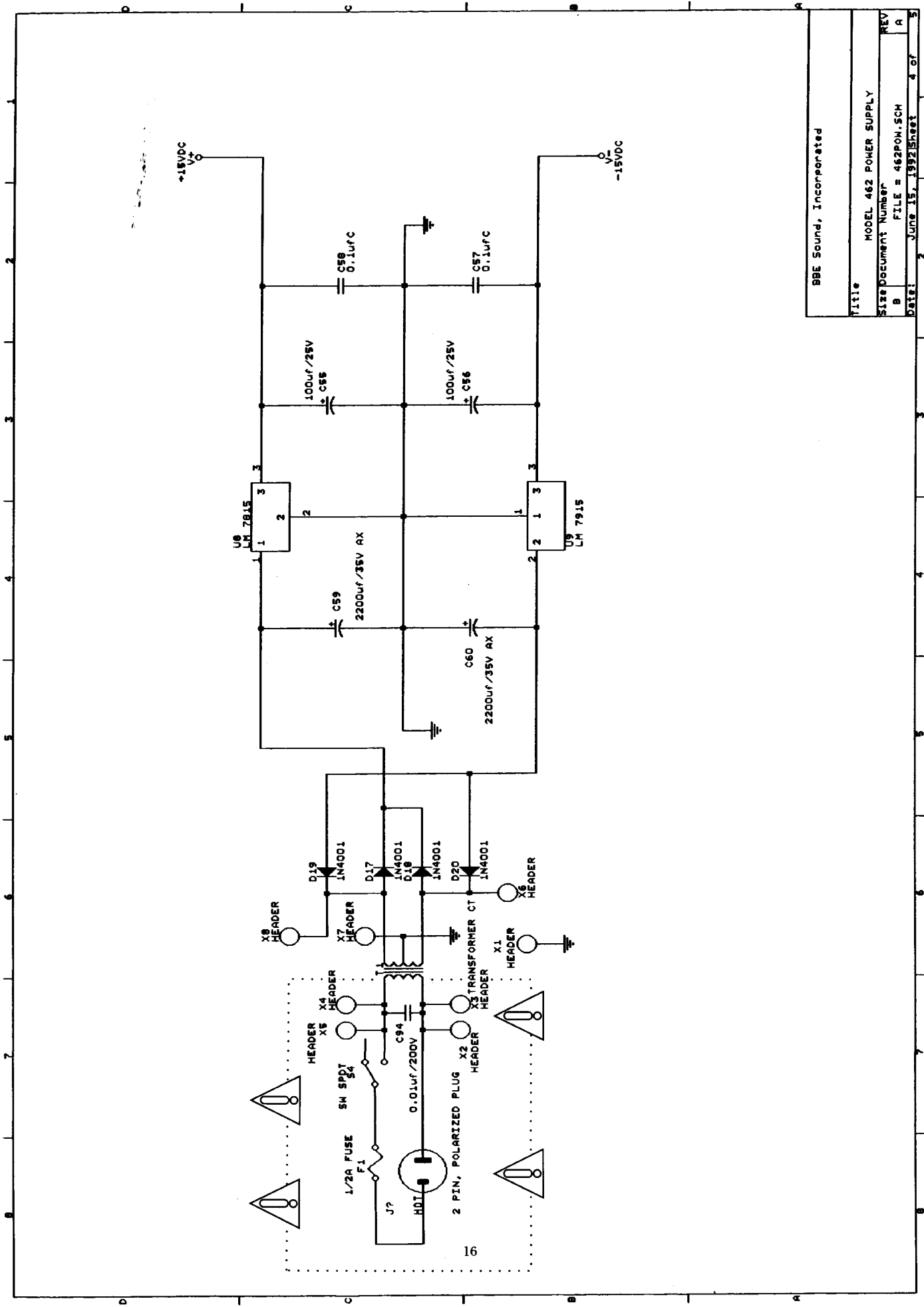

| | |
|-------------------------|----------------------------|
| BBE Sound, Incorporated | |
| Title | MODEL 462 POWER SUPPLY |
| Size Document Number | B |
| REV | FILE = 462PON.SCH |
| Date: | June 15, 1992 Sheet 4 of 5 |

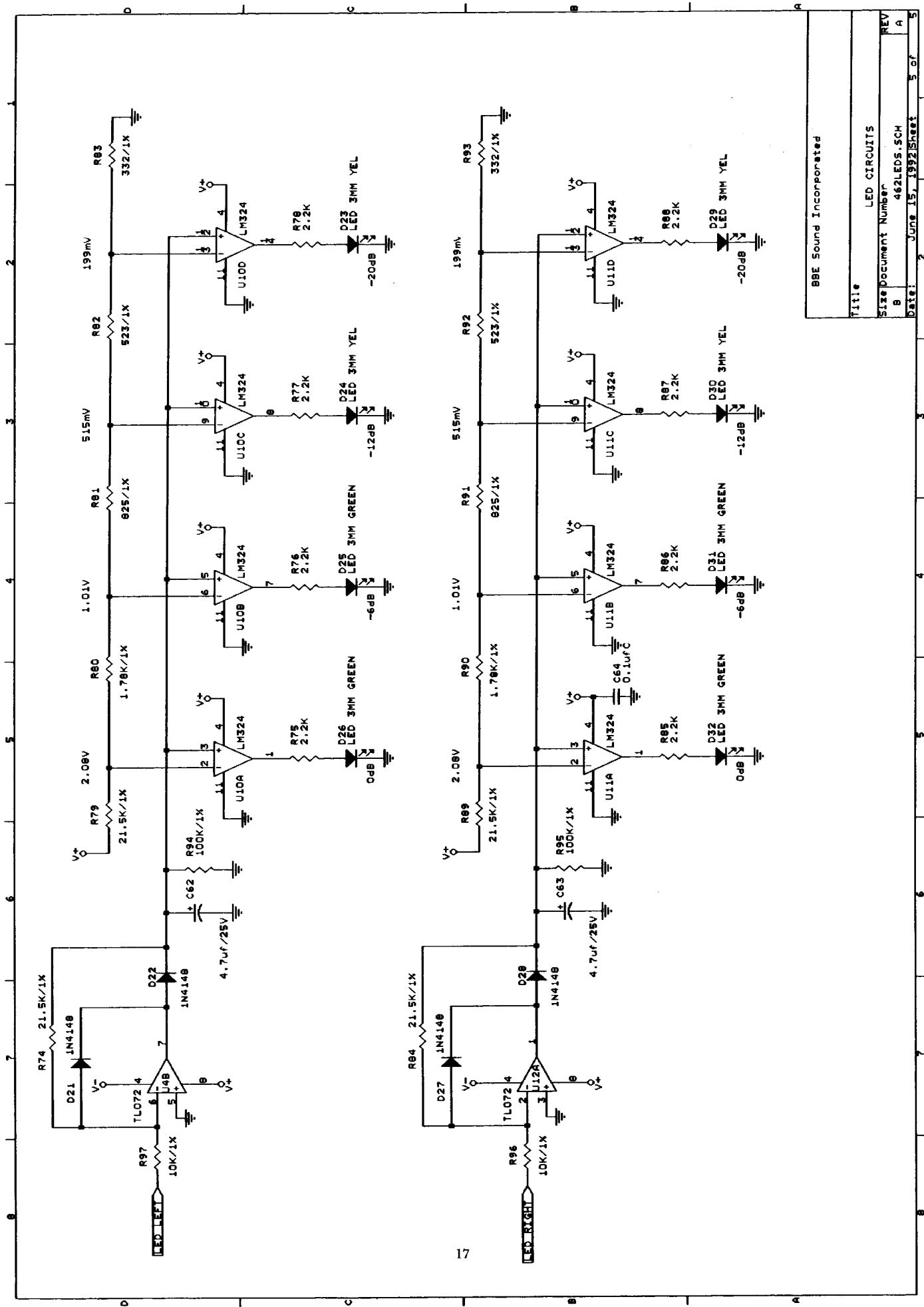

| | |
|------------------------|------------------------------|
| BBE Sound Incorporated | |
| Title | LED CIRCUITS |
| Size | Document Number |
| REV | 462LEDS.SCH |
| B | A |
| Date: | 2 June 15, 1992/Sheet 1 of 5 |



BBE[®]
Sound Inc.

CALIFORNIA, U.S.A.
(714)897-6766 * FAX(714)895-6728

BBE is a registered trademark of BBE Sound, Inc.

Covered by U.S. Patent 4,482,866 and other U.S. and foreign patents pending.
BBE is the registered trademark of BBE Sound, Inc.

Free Manuals Download Website

<http://myh66.com>

<http://usermanuals.us>

<http://www.somanuals.com>

<http://www.4manuals.cc>

<http://www.manual-lib.com>

<http://www.404manual.com>

<http://www.luxmanual.com>

<http://aubethermostatmanual.com>

Golf course search by state

<http://golfingnear.com>

Email search by domain

<http://emailbydomain.com>

Auto manuals search

<http://auto.somanuals.com>

TV manuals search

<http://tv.somanuals.com>