

owners manual

**Model No.
45-02171
190-521-000**

IMPORTANT:

Read Rules for
Safe Operation
and Instructions
Carefully

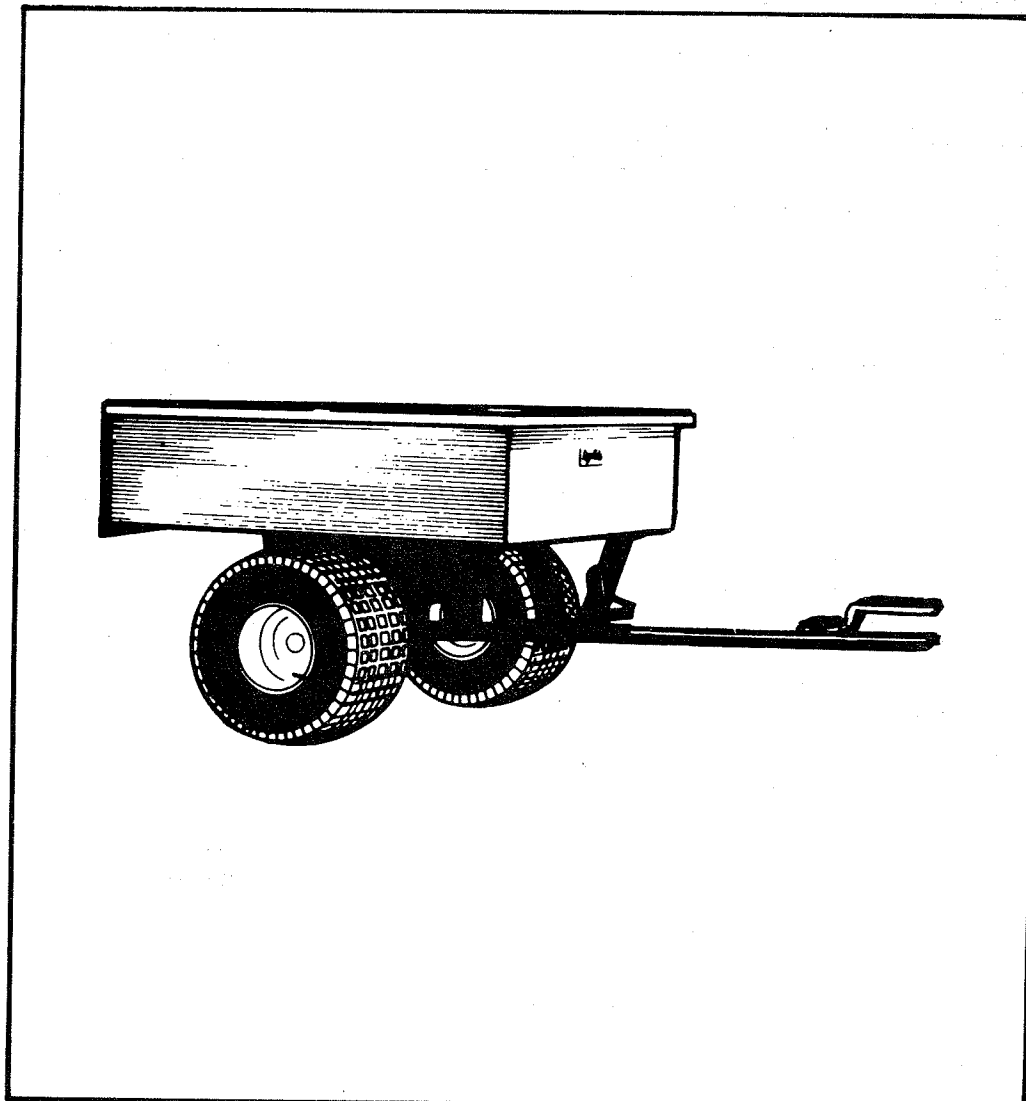

UTILITY CART 17 CU. FT. (SUPER 17)

- **Assembly**
- **Operating**
- **Maintenance**
- **Repair Parts**

Agri-Fab
INC

• 303 WEST RAYMOND • SULLIVAN, ILLINOIS 61951

PRINTED IN U.S.A

Download from Www.Somanuals.com. All Manuals Search And Download.

FORM NO. 46085
(Rev. 11/94)

ASSEMBLY INSTRUCTIONS

Contents of Hardware Pack
(See figure 1)

REF.	QTY.	DESCRIPTION
A	2	Tube Spacer 1-1/4" O.D. x 2" Lg.
B	2	Pin, Cotter 1/8 x 1-1/2" Long
C	2	Hex Nut 3/8 Thread
D	4	Washer, Flat 1.032 I.D.
E	2	Hub Cap
F	23	Hex Bolt 1/4 x 1/2" Long
G	6	Hex Bolt 1/4 x 5/8" Long
H	6	Hex Bolt 1/4- 3/4" Long
I	2	Lock Washer 3/8" I.D.
J	2	Hex Bolt 1/4 x 1-3/4" Long
K	37	Lock Washer 1/4" I.D.
L	37	Hex Nut 1/4" Thread
M	8	Hex Bolt 5/16 x 3/4" Long
N	8	Lock Nut 5/16" Thread
O	14	Slotted Truss Head Bolt 5/16" x 3/4" Long
P	14	Lock Washer 5/16" I.D.
Q	14	Hex Nut 5/16" Thread
R	2	Hex Bolt 3/8" x 1" Long

IDENTIFICATION OF LOOSE PARTS (See figure 2)

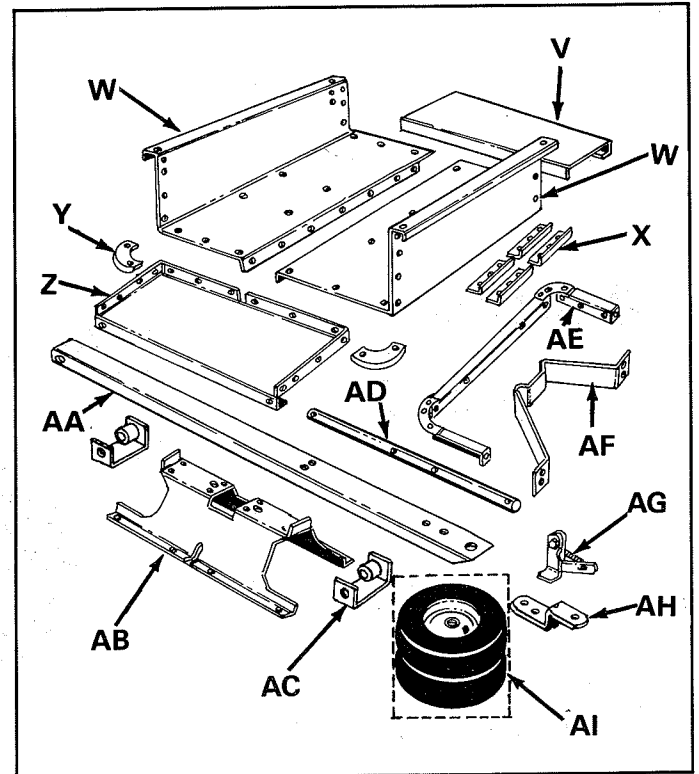

FIGURE 2

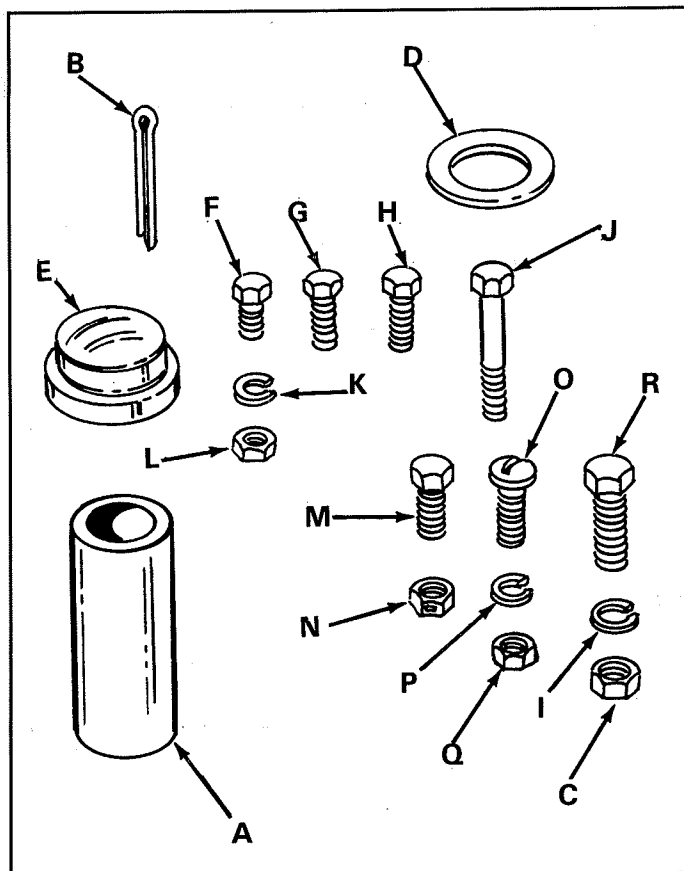

FIGURE 1



Wheels (AI) are packed in a separate carton).

LOOSE PARTS (See figure 2)

- V Tailgate
- W Cart Body (2)
- X Tailgate Guides
- Y Corner Caps
- Z Front Panel
- AA Draw Bar Tongue
- AB Wheel Support
- AC Wheel Axle Brackets
- AD Axle
- AE Tailgate Reinforcement Bracket
- AF Latch Stand Bracket
- AG Latch Lock Sub-Assembly
- AH Hitch Bracket
- AI Wheels

1. Remove the hardware pack and all loose parts from the carton. Be sure carton is empty before discarding.
2. Layout all the parts as shown in figure 2.
3. Position the cart body halves (W) upright, on a smooth level surface, as shown in figure 3.



CAUTION

To help prevent tipping of cart, assemble on a smooth level surface such as a garage floor or a paved driveway. Pay close attention to stability of the cart body when it is in an upright position. **DO NOT LEAVE THE CART UNATTENDED IN UPRIGHT POSITION.** The cart could be knocked over causing personal injury or damage to the cart.

4. Assemble the bolts (F), the lock washers (K) and hex nuts (L) to the holes in center flanges. **Do not tighten till step 15, page 5.** See figure 3.
5. Position the wheel support (AB) in place on the bottom of the cart. See figure 4.
6. Assemble wheel support to cart with eight slotted head screws (O) lock washers (P) and hex nuts (Q). The heads of the screws should go to the inside of the cart bed as shown in figure 4. These screws should be tightened after they are all assembled.

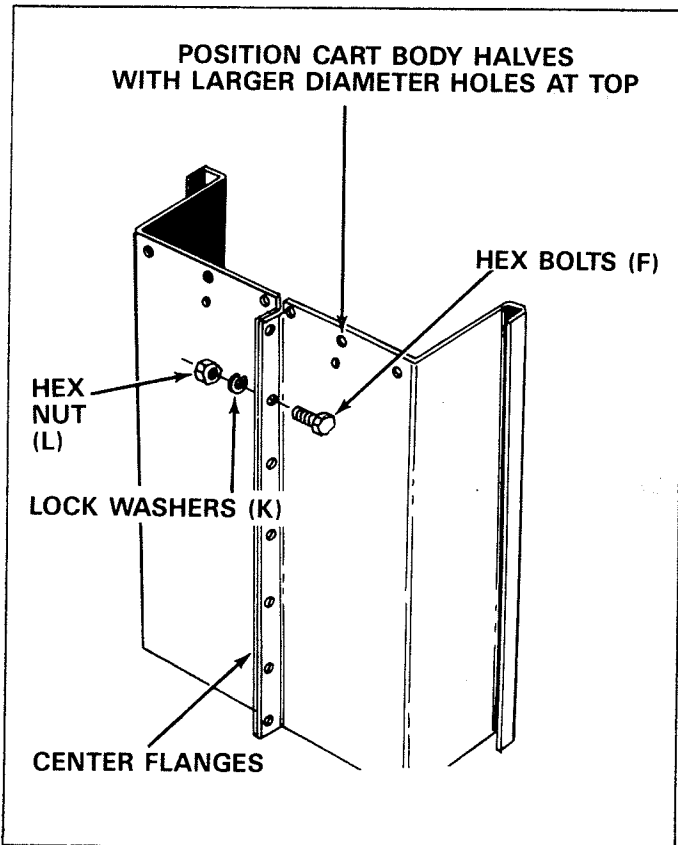

FIGURE 3

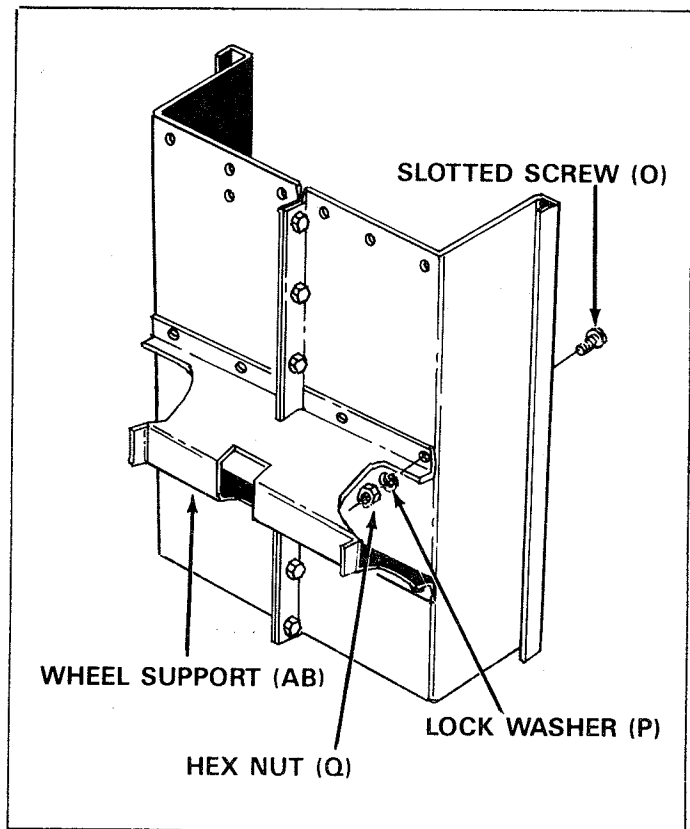

FIGURE 4

7. Position the tailgate reinforcement bracket (AE) over end of cart. See figure 5.
8. Start slotted screws (O) through bottom of cart (heads of screws to the inside of cart) and reinforcement bracket. Secure finger tight with hex nuts (Q) and lock washers (P). See figure 5.
9. Position the tailgate guides (X) so that the holes line up with reinforcement bracket and cart body. Refer to tailgate guide detail in figure 5.
10. Secure tailgate guides with six hex bolts (H) lock washers (K) and hex nuts (L). See figure 5. Tighten bolts assembled in steps 7, 8 and 9 at this time. Do not tighten others.

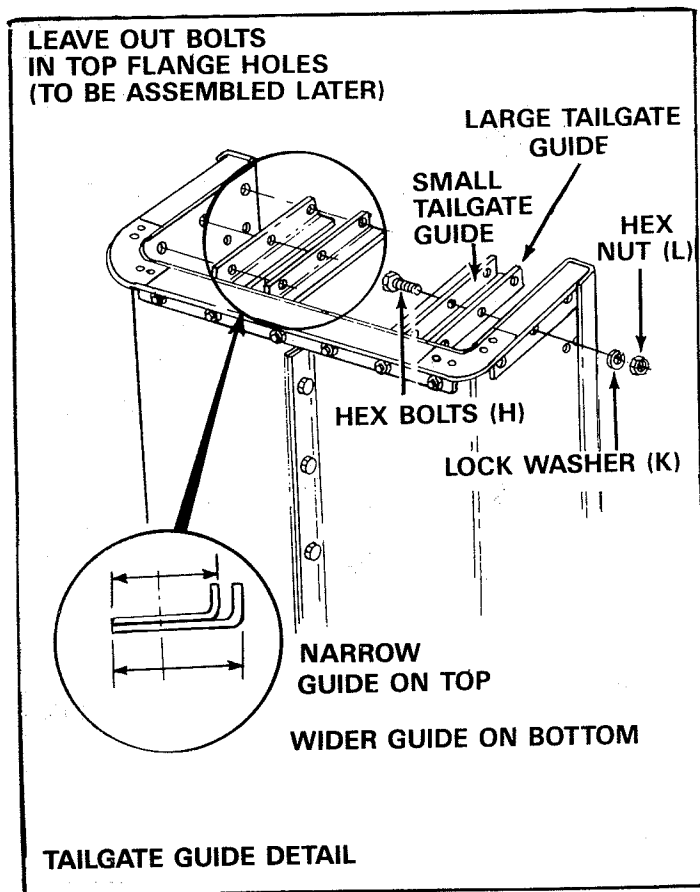

FIGURE 5

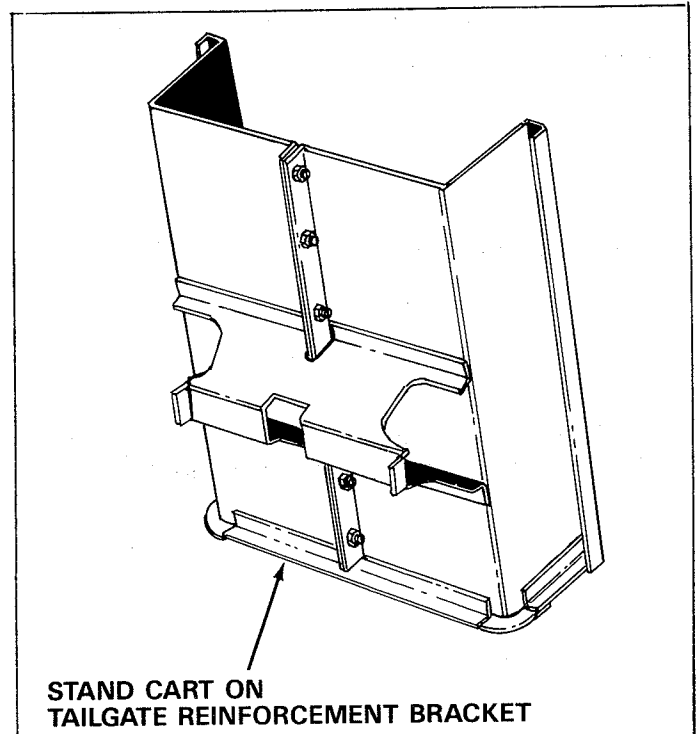

FIGURE 6

11. Reverse the cart position and stand on tailgate reinforcement bracket and proceed with assembly steps 12 through 20. See figure 6.
12. Assemble front panel to open end of cart body, using 1/4" x 1/2" hex bolts (F), lock washers (K) and hex nuts (L). Bolt heads to inside of cart. Leave out (2) bolts for latch stand bracket. See figure 7.

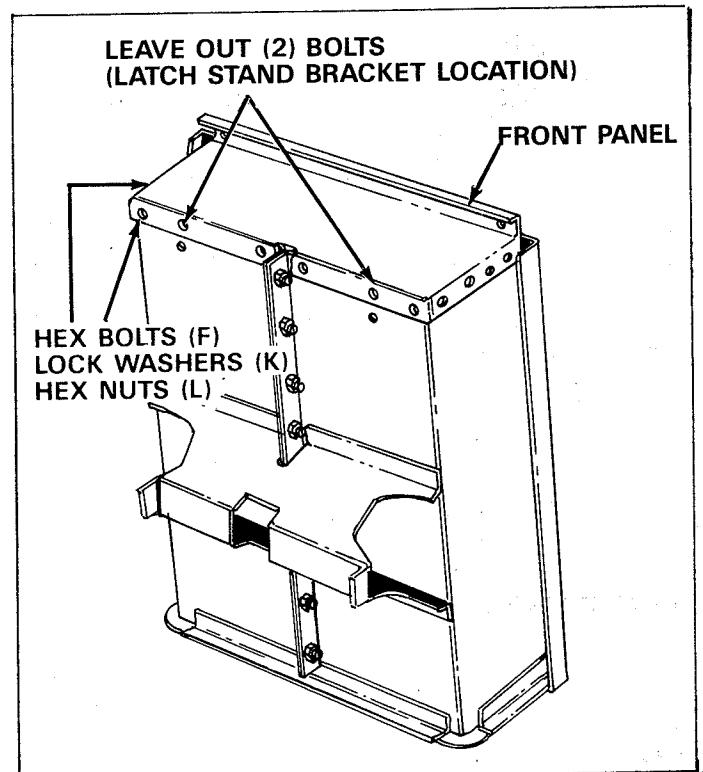

FIGURE 7

13. Assemble latch stand bracket using four 1/4" x 5/8" hex bolts (G), lock washers (K) and hex nuts (L). See figure 8.

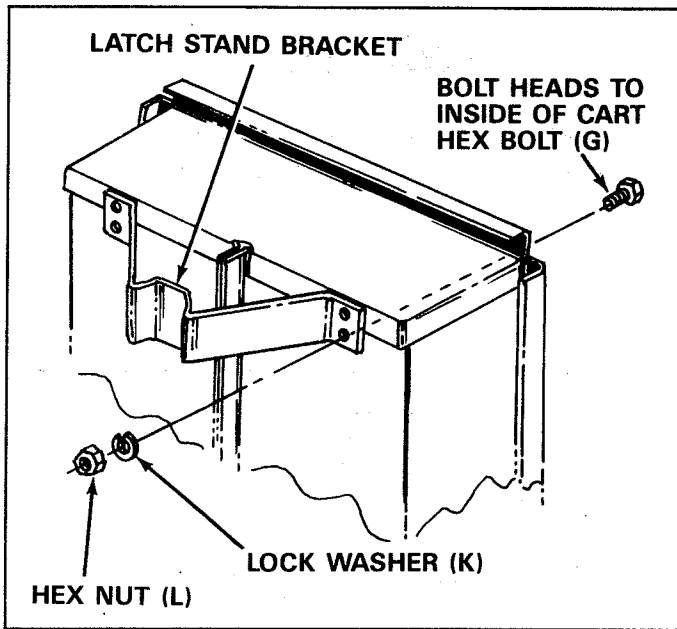

FIGURE 8

14. Assemble two front top corner caps and two bolts in top flanges through tailgate reinforcement bracket using 1/4" x 1/2" hex bolts (F), lock washers (K) and hex nuts (L). See figure 9.

15. Tighten all bolts assembled in step 4 through 14, lower cart assembly to rest on top flanges, with axle support up. See figures 10 and 13.

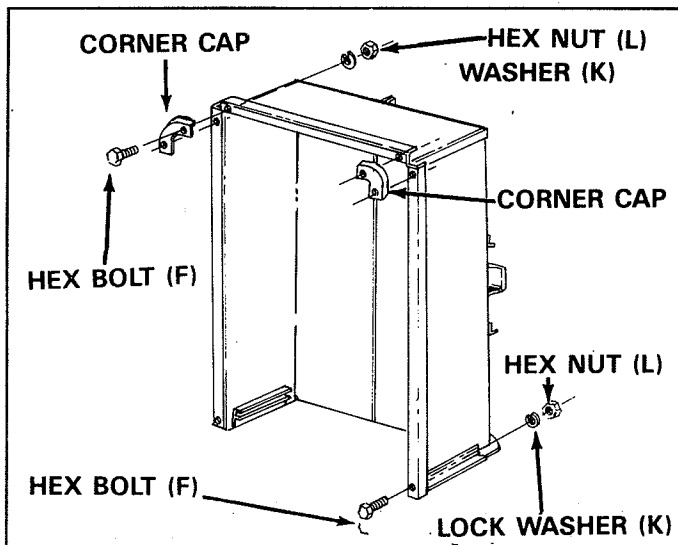

FIGURE 9

16. Assemble wheel axle brackets (2) to wheel support, using 5/16" x 3/4" hex bolts (M) and lock nuts (N). NOTE: Place welded tubes to middle, as shown in figure 10.

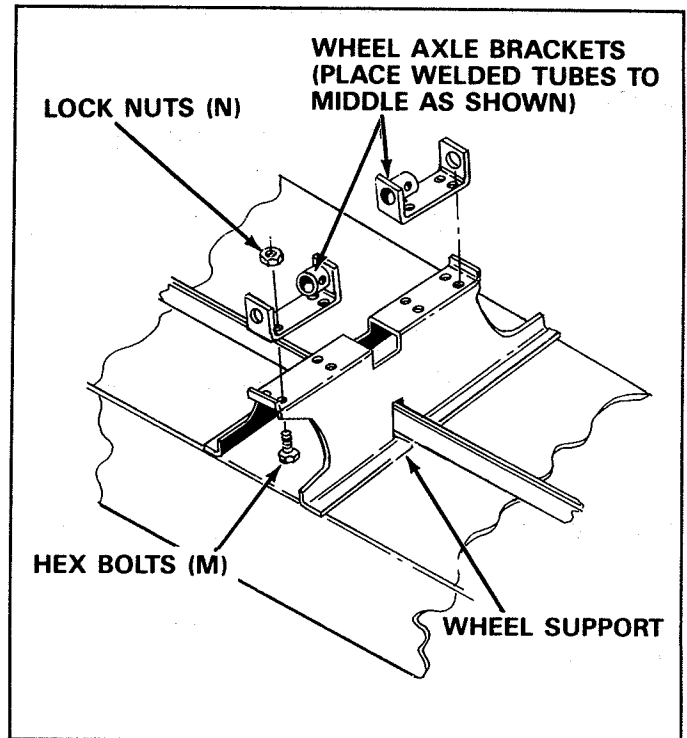

FIGURE 10

17. Assemble latch lock subassembly to drawbar tongue using 1/4" x 5/8" long hex bolt (G), lock washers (K) and hex nuts (L). See figure 11.

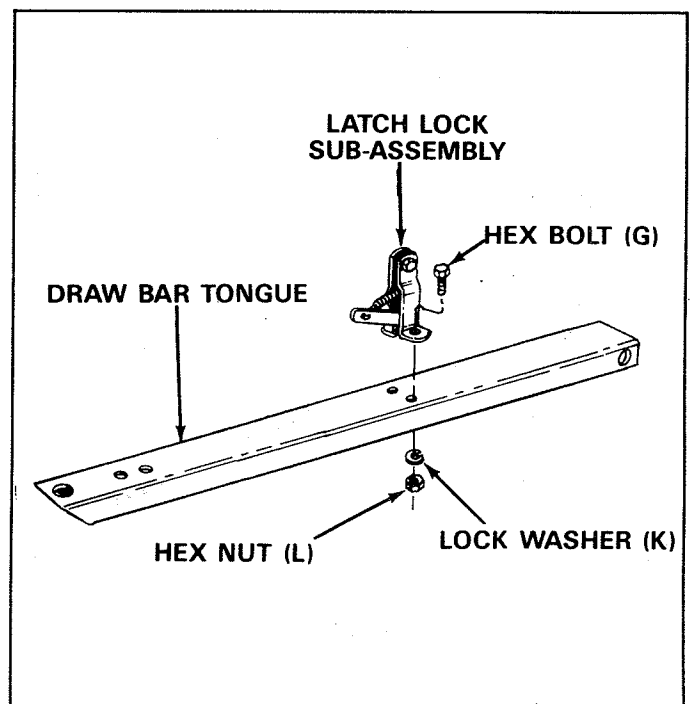

FIGURE 11

18. Assemble hitch bracket to drawbar tongue, using 3/8" x 1" long hex bolts (R), lock washers (I) and hex nuts (C). See figure 12.

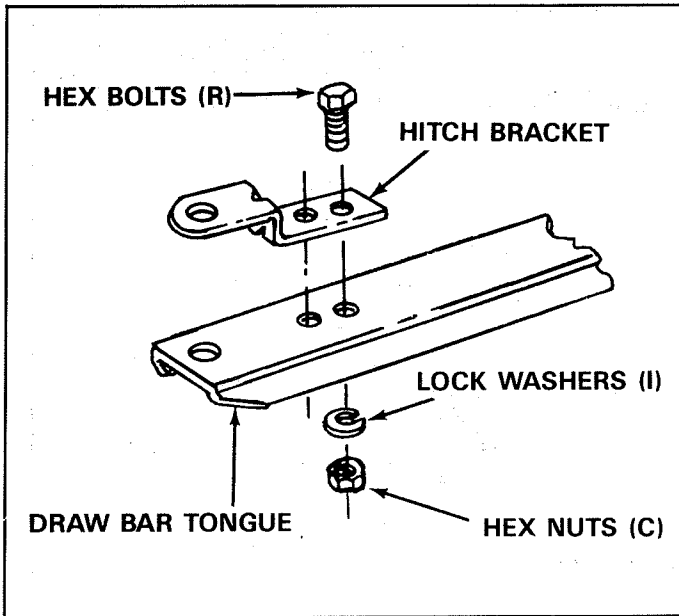

FIGURE 12

19. Assemble axle, (2) tube spacers and draw bar tongue to wheel support keeping open side of tongue facing up, make sure that latch lock snaps over latch stand. Secure axle to wheel support or axle brackets, using 1/4" x 1-3/4" long hex bolts (J), lock washers (K) and hex nuts (L). See figure 13.

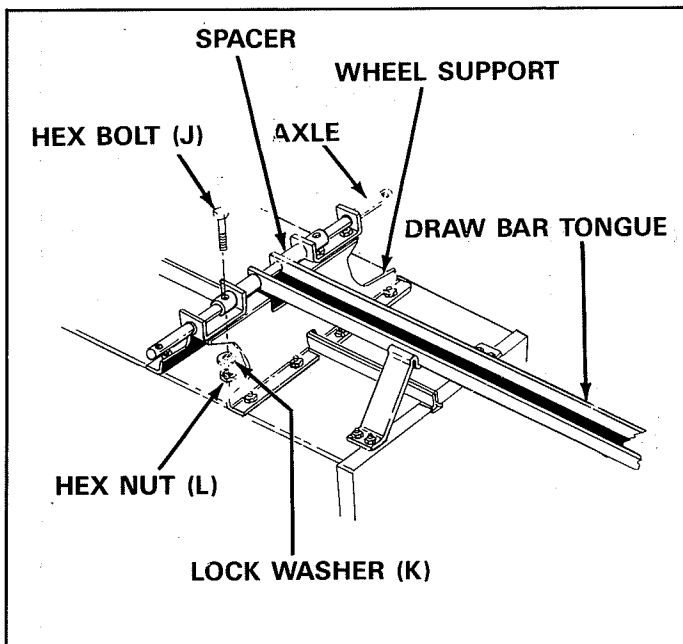

FIGURE 13

20. Assemble large diameter flat washer (D), wheel, another flat washer (D), cotter key (B) and hub cap (E) to each axle end.



Position valve stem to outside when installing wheels on axle. See figure 14.

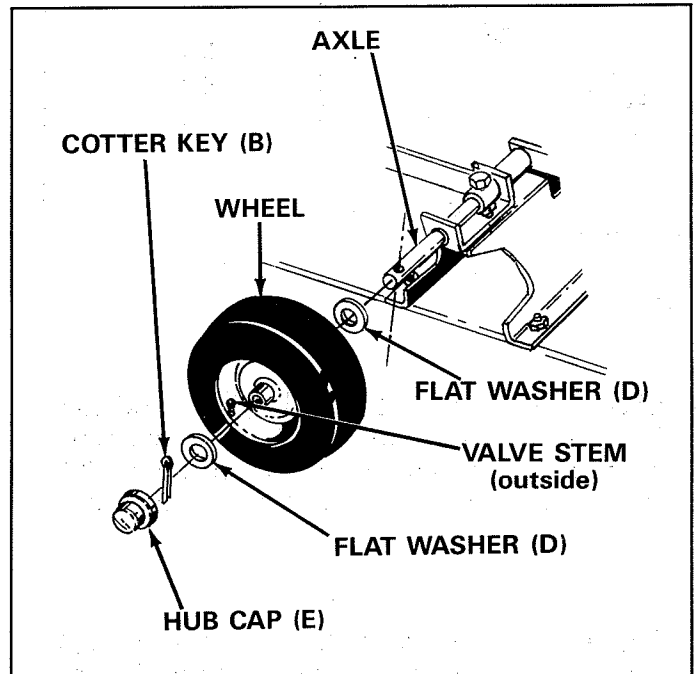

FIGURE 14

21. Turn cart assembly over to rest on wheels. This completes the cart assembly. Be sure to read safety rules and operating instructions before using your new utility cart.

GENERAL SAFETY PRECAUTIONS

Preventing accidents is the responsibility of every equipment operator. The following general safety precautions must be fully understood and followed by every operator.

1. Do not at anytime carry passengers in this cart. It is designed for carrying materials only and not intended to carry passengers.
2. Do not tow this utility cart on a public thoroughfare at any time. The operator is risking injury from passing vehicles. Most local ordinances prohibit operating a cart and tractor such as this on a public thoroughfare.
3. When towing cart do not drive too close to a creek or ditch and be alert for holes and other hazards. The above could cause you to lose control of the cart and tractor.
4. Be careful on any grade (hill) and stay off of steep grades.
5. Maximum towing speed - 10 M.P.H.

OPERATION

To dump material from the trailer box, remove the tailgate by lifting it straight up and out from between the guides. Release the spring latch by pulling the latch handle forward, away from the trailer box.



CAUTION

To avoid possible injury, be sure that no one is near the trailer before releasing latch.

A cord may be attached to the spring latch handle for easy release by the operator while in the tractor's seat. The trailer box will tilt backward to empty its contents. After unloading, pull the front of the box down toward the trailer tongue until the latch snaps in place. Replace tailgate if desired.



NOTE

For best handling, do not load trailer too heavily behind center of axle.

MAINTENANCE

At the beginning of each season, lubricate the latch, latch pivot bolt, and the axle where the hitch tongue pivots, with a light machine oil.

1. Grease or oil wheel bearings occasionally. Use automotive wheel bearing type grease or 20 weight oil.
2. Recommended tire pressure is 12-14 Lbs.



NOTE

Weight limit-*One cubic foot of dirt weights approximately 150 lbs.*

Do Not exceed cart weight capacity.

SPECIFICATIONS; MODEL 45-0217 — 17.0 Cu. Ft. (Super 17)

Bed:	16 Ga. Steel Construction 36-1/2" W; 61" L; 14" H; Approx. Inside Dim. — 34" x 58-1/2"
Tailgate:	Removable with Reinforced Guides
Tires:	20.0" x 10.0" Pneumatic, Turf Tread
Axle:	1.0" Dia. Steel
Capacity:	Up to 1700 Lbs. Max.
Finish:	Baked Enamel—Body; Ivory; Black
Approx. Sh. Wt.:	195 Lbs.
Carton Size:	16-1/2" H x 20-1/2" W x 60-1/2" (11.55 Cu. Ft.)
Carton Size:	20-1/2" H x 20-1/2" W x 20-1/2" L (4.99 Cu. Ft.)

REPAIR PARTS FOR: UTILITY CART MODEL NO. 45-02171

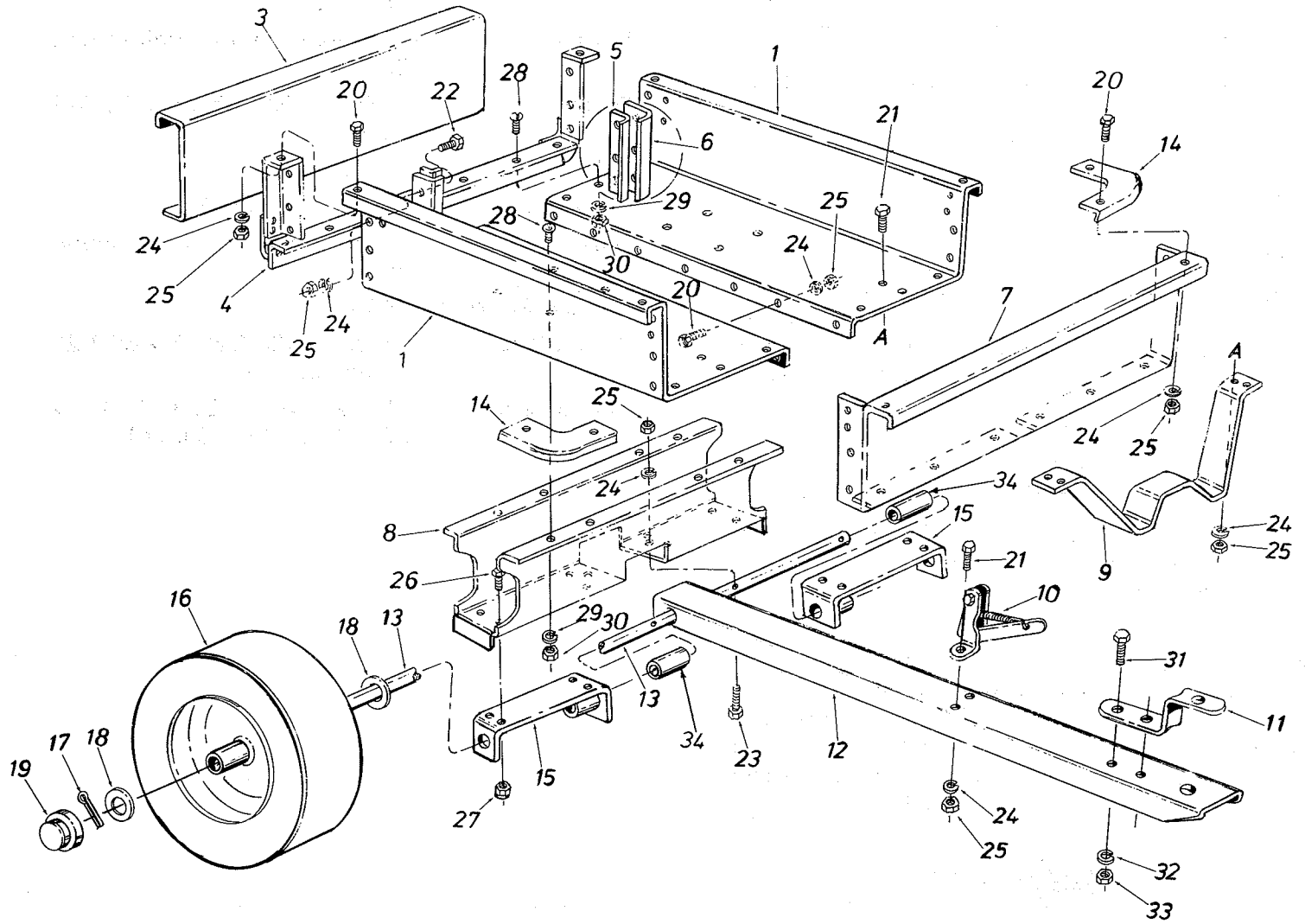

PARTS LIST FOR UTILITY CART MODEL NO. 45-02171

REF. NO.	PART NO.	QTY.	DESCRIPTION
1	23984	2	Cart Body
3	23504	1	Tailgate
4	62457	1	Sub-Ass'y., Rear Angle
5	23549	2	Guide, Tailgate — Inside
6	23548	2	Guide, Tailgate — Outside
7	23490	1	Front Panel
8	23821	1	Wheel Support
9	23363	1	Latch Stand Bracket
10	62455	1	Ass'y. Latch Lock
11	23014	1	Hitch Bracket
12	23989	1	Draw Bar Tongue
13	23820	1	Wheel Axle 1" Dia.
14	23484	2	Cap, Front Corner
15	62359	2	Wheel Axle Bracket
16	43649	2	Wheel, 20 x 10-8
17	43093	2	Cotter Pin 1/8" Dia. x 1-1/2" Lg.
18	43601	4	Washer, Flat 1.032" I.D.
19	43014	2	Hub Cap
20	43175	25	Hex Bolt 1/4" x 1/2" Lg.
21	43866	6	Hex Bolt 1/4" x 5/8" Lg.
22	43012	6	Hex Bolt 1/4" x 3/4" Lg.
23	1509-69	2	Hex Bolt 1/4" x 1-3/4" Lg.
24	43177	39	Lock Washer 1/4" I.D.
25	43178	39	Hex Nut 1/4" Thread
26	43182	8	Hex Bolt 5/6-3/4" Lg.
27	43064	8	Lock Nut 5/6" Thread
28	43814	14	Slotted Truss Head Bolt 5/16" x 3/4" Lg.
29	43086	14	Lock Washer 5/16" I.D.
30	43083	14	Hex Nut 5/16" Thread
31	43001	2	Lock Washer 3/8" x 1" I.D.
32	43003	2	Lock Washer 3/8" I.D.
33	43015	2	Hex Nut 3/8" Thread
34	44678	2	Tube Spacer
	46085	1	Owner's Manual

...

REPAIR PARTS

303 West Raymond Street

Sullivan, Illinois 61951

(217) 728-8388

Free Manuals Download Website

<http://myh66.com>

<http://usermanuals.us>

<http://www.somanuals.com>

<http://www.4manuals.cc>

<http://www.manual-lib.com>

<http://www.404manual.com>

<http://www.luxmanual.com>

<http://aubethermostatmanual.com>

Golf course search by state

<http://golfingnear.com>

Email search by domain

<http://emailbydomain.com>

Auto manuals search

<http://auto.somanuals.com>

TV manuals search

<http://tv.somanuals.com>