

Type ES56()

5.6-Meter ESA



5.6-Meter Earth Station Antenna

Table of

Introduction	Introduction	3
	<i>Proprietary Data</i>	4
	<i>Information and Assistance</i>	4
	<i>Notice</i>	4
	<i>Technical Assistance</i>	4
How to Use This Manual	Overview	5
	Content	5
Getting Started	Overview	6
	Warnings	6
	Recommended Tools	7
	Parts Verification	8
	Reporting Equipment Loss or Damage	8
	Reporting Visible Loss or Damage	8
	Reporting Concealed Damage	8
	Inventory Equipment Received	8
	Returning Equipment	9
Installation Procedures	Overview	10
	Foundation Preparation	10
	A-325 Tensioning	11
	Tripod Ground Mount Assembly	12
	Azimuth Beam Assembly	12
	Support Legs Assembly	13
	Panning Frame Assembly	16
	Elevation Jackscrew Assembly	23
	Azimuth Jackscrew Assembly	25
	Mount Assembly	25
	Reflector/Backstructure Installation Drawing (239352)	30
	Subreflector and Subreflector Strut Installation Drawing (239438)	37
Operation	Overview	39
	Acquiring A Satellite	39
	Subreflector Adjustment	43
Preventive Maintenance	Overview	44
	General Cleaning	44
	Electrical Parts	44
	Mechanical Parts	45
	Inspection	45
	Local Control/Motor Drive Controller	45
	Antenna	46
	Drive System Voltage and Current Checks	48
	Preservation of Component Parts	50
	Aluminum Parts	50
	Galvanized Surfaces	50
	Lubrication	50
	Jackscrews/Motors	51
	Gear Motor/Housing Fill Drain Requirements	51

5.6-Meter Earth Station Antenna

Introduction

Like all Andrew earth station antennas, the 5.6-Meter Earth Station Antenna provides high gain and exceptional pattern characteristics. The electrical performance and exceptional versatility provides the ability to configure the antenna with your choice of linearly- or circularly-polarized 2-port or 4-port combining network. That versatility is provided at the time of initial purchase, as well as in the future, as your satellite communication requirements evolve.

The aluminum reflector is precision formed for accuracy and strength requiring minimal assembly. The reflector assembly is 18.3-feet (5.6-meters) in diameter and segmented in a sixteen piece configuration to reduce shipping volume and facilitate transport to remote sites. Reflector panels are chromate converted and painted with a highly reflective white paint.

The versatile tripod mount can be purchased with either manual or motorizable capabilities. The tripod mount features 180 degree azimuth coverage in three continuous 120 degree overlapping ranges and executes 90 degree continuous elevation adjustment. This large adjustment range provides non-critical foundation orientation and the ability to view geostationary satellites from horizon-to-horizon, from any location worldwide.

The motorizable tripod mount features self-aligning bearings for the elevation pivots, resulting in "zero" backlash. This mount can be operated manually, but has the ability to be upgraded for motorized operation, including steptracking/Smartrack™ applications. The motorizable mount type is indicated by the **ES56** or **ES56HS** letters within the antenna type number. The addition of the letter "HS" within the antenna type number indicates that the mount includes High-Speed azimuth/elevation machine jackscrews, instead of corresponding azimuth/elevation strut assemblies. The azimuth/elevation jackscrews are equipped for integration with the optional motor drive systems. A cross-axis grounding kit is supplied with each mount to ensure electrical interconnectivity of the complete structure.

The aluminum enclosure and hot-dipped galvanized steel mount maintain pointing accuracy and ensures durability and reliability. The antenna and standard manual mount with enclosure will survive 125 mph (200 km/h) wind, in any position of operation, without damage or permanent deformation in moderate coastal/industrial areas. Severe conditions require additional protection.

Andrew provides a complete line of available options, including motor drive systems (with power interfaces addressing domestic and international standards), remote micro-processor antenna control for motor drive systems, pressurization equipment, and inter-connecting HELIAX® cables and waveguide.

Proprietary Data

The technical data contained herein is proprietary to Andrew Corporation. It is intended for use in operation and maintenance of Andrew supplied equipment. This data shall not be disclosed or duplicated in whole or in part without express written consent of Andrew Corporation.

Information and Assistance

Andrew Corporation provides a world-wide technical support network. Refer to the technical assistance portion of this manual for the contact numbers appropriate to your location.

Notice

The installation, maintenance, or removal of antenna systems requires qualified, experienced personnel. Andrew installation instructions have been written for such personnel. Antenna systems should be inspected by qualified personnel to verify proper installation, maintenance and condition of equipment.

Andrew Corporation disclaims any liability or responsibility for the results of improper or unsafe installation and maintenance practices.

All designs, specifications, and availabilities of products and services presented in this manual are subject to change without notice.

Copyright © 2004, Andrew Corporation

Technical Assistance

24-hour Technical Assistance

For technical assistance, call the following numbers at anytime.

Call From	Call To	Telephone	Fax
North America (toll free)	U. S. A.	1-(800)-255-1479	(800)-349-5444
Any Location (International)	U. S. A.	(708)-349-3300	(708)-349-5410

Customer Service Center

The Andrew Customer Service Center gives you direct access to the information and personnel service you need, such as the following:

- Place or change orders
- Check price and delivery information
- Request technical literature

You can call from any of the following:

Call From	Telephone	Fax
North America	1-800-255-1479 (toll free)	1-(800)-349-5444 (toll free)
United Kingdom	00-800-0-255-1479 (toll free)	00-800-0-349-5444 (toll free)
Australia	0011-800-0-255-1479 (toll free)	0011-800-0-349-5444 (toll free)
China	00-800-0-255-1479 (toll free)	00-800-0-349-5444 (toll free)
New Zealand	00-800-0-255-1479 (toll free)	00-800-0-349-5444 (toll free)
Hong Kong	001-800-0-255-1479 (toll free)	001-800-0-349-5444 (toll free)



How to Use This Manual

Overview

The scope of this manual is intended to provide station personnel with the base installation, operation, and maintenance requirements necessary for a 5.6-Meter C-, X- or Ku-Band Earth Station Antenna. This manual provides a convenient reference for authorized operator/service personnel requiring technical information on general system or specific subsystem equipment.

The tables and figures presented in this manual are used as communication aids for the installation, operation, and maintenance of the 5.6-Meter Earth Station Antenna. These tables and figures instantly convey messages, as well as make the procedures easier to understand. This manual uses tables and figures for the following references:

- **Tables** The tables allow you to locate information quickly and easily.
- **Drawings** The drawings supplement the installation instructions by using a combination of graphics and verbage to assist you in simplifying complex procedures and clarifying components.
- **Photographs** The photographs compliment the installation instructions by providing actual examples of the steps being performed, which allow you to view the installation in concrete form.

Content

The manual is divided into five distinct sections, each dealing with a specific technical topic relating to either system or component subsystem information. The sections contained in this manual are described and listed under the following technical headings:

- **How to Use This Manual** Describes the manual's purpose, content, and communication aids. Additionally, this section lists the related documentation for the 5.6-Meter Earth Station Antenna.
- **Getting Started** Provides the preliminary information needed to perform a successful installation. This section should be reviewed prior to the installation. The warnings, recommended tools, parts verification, instructions on reporting lost or damaged equipment, and installation checklist are located in this section.
- **Installation Procedures** Provides the procedures for the different phases of a 5.6-Meter Earth Station Antenna base installation. This section will help you easily find requirements for an individual task, as well as displays the sequence for each task execution.
- **Operation** Describes the controls, functions, and general operating procedures required for proper operation of the 5.6-Meter Andrew Earth Station Antenna.
- **Preventive Maintenance** Describes preventive maintenance procedures that are required to maintain proper functional operation of your new Andrew Earth Station Antenna.

Getting Started

Overview

The installation, operation, and maintenance of the 5.6-Meter Earth Station Antenna requires qualified and experienced personnel. Andrew installation, operation, and maintenance instructions are illustrated for such personnel. Additionally, the antenna should be inspected by qualified personnel to verify proper installation, maintenance, and condition of equipment as described in Preventive Maintenance. The basic equipment and accessories are either manufactured or design controlled by Andrew Corporation.

The prerequisite information necessary for the 5.6-Meter Earth Station Antenna can be found in this section. Furthermore, this section should be reviewed BEFORE performing the installation, operation, or maintenance. Warnings, recommended tools, and the antenna parts can be verified and/or determined with such a review.

Warnings

When installing the 5.6-Meter Earth Station Antenna, be conscious of the warnings presented below. For further information or clarification of this information, contact the Customer Service Center. The warnings are as follows:

1. Electrical shock from voltages used in this antenna system may cause personal injury or death. Prior to making any electrical connections or performing maintenance or repair, ensure that the power is removed. Electrical connections should be made only by qualified personnel in accordance with local regulations.
2. Installation of antennas may require persons to work at elevated work stations. Whenever persons are working at eight or more feet above the ground and not on a guarded platform, they should wear safety belts with at least one (preferably two) lanyards.
3. Never stand underneath any object while it is being lifted.
4. Always wear a hard hat, especially if someone is above you.
5. Make sure no person is in or under the reflector while it is being lifted or positioned; personal injury can result if the reflector assembly falls.
6. Personnel should never be hoisted in or out of the reflector by the crane; personal injury may result.
7. Andrew earth station antennas supplied to standard product specifications will survive 125 mph winds in any operational position in moderate coastal/industrial areas. Severe conditions require additional protection. Should it be expected that winds will exceed 125 mph, it is recommended that Andrew antennas be steered to specific azimuth and elevation orientations to minimize wind forces upon the structure and thereby increase the probability of survival.
8. It is recommended that all cross-axis waveguide and coaxial cables are secure such that high winds will not cause excessive flexing. Position the antenna to an elevation of 90 degrees. The azimuth jackscrew should be placed in the center of its travel.
9. When the antenna is transmitting, severe eye injury or injury to other parts of the body can result from exposure to radio frequency (RF) energy. The antenna must be turned off before entering the area in front of the reflector and near the feed.

NOTE: Failure to follow an installation procedure could result in damage to equipment or personal injury.

Additional warnings will be displayed throughout this manual for your awareness. These warnings can be identified in warning boxes as shown in the following sample.



Andrew disclaims any liability or responsibility for the results of improper or unsafe installation, operation, or maintenance practices.

Recommended Tools

Andrew supplies all appropriate hardware/parts required for the installation of your 5.6-Meter Earth Station Antenna. All tools necessary for the installation process should be provided by the installation crew. Andrew recommends the following tools to be used for a proper installation of the 5.6-Meter Earth Station Antenna.

Tool	Size	Quantity
Open End or Combination Wrenches	5/16 Inch	2
	7/16 Inch	2
	9/16 Inch	2
	7/8 Inch	2
	3/4 Inch	2
	1/2 Inch	2
	1-1/4 Inch	1
Crane	1 Ton Minimum Capacity, extended end	1
Nylon Web Slings (2000 pound breaking strength)	3 Inch by 14 Foot	2
Rope or Cord (2000 pound breaking strength)	50 Foot	1
Shackles	5/8 Inch	2
Ladder	10 Foot Extension	1
Drive Sockets	1/16 Inch	1
	9/16 Inch	1
	7/8 Inch	1
	3/4 Inch	1
	1-1/4 Inch	1
Breaker Bar	1/2 Inch	1
Spud Wrenches	1-1/16 Inch	1
	1-1/4 Inch	1
Screw Driver	Standard	1
	Phillips	1
Allen Wrench	7/64 Inch	1
	3/16 Inch	1
	1/4 Inch	1
Tape Measure (or other measuring device)	Standard	1
Felt-tip Marker (or other marking device)	Standard	1
Hammer	Standard	1
Rubber Mallet	Standard	1
Pry Bar	Standard	1
Tin Snips	Standard	1
Safety Gloves (each installer)	Standard	1

Table 2-1. Recommended Tools

Parts Verification

Upon receipt of your order, the shipment should be verified to ensure that all parts have reached your site. This process should occur before the installation process begins.

Andrew Corporation thoroughly inspects and carefully packs all equipment before shipment. If you find that there are missing components, please refer to page 9 for step-by-step instructions on how to properly report the equipment loss.

When you have received your order, verify that all parts contained in the shipment correspond to the parts listed on your packing list.

Reporting Equipment Loss or Damage

If you find that there was damage caused to the equipment during the shipping process, a claim should be filed with the carrier. Follow the "Reporting Visible Loss or Damage" or "Reporting Concealed Damage" procedures when filing a claim with the carrier.

Reporting Visible Loss or Damage

Make a note of any loss or evidence of external damage on the freight bill or receipt, and have it signed by the carrier's agent. Failure to adequately describe such external evidence of loss or damage may result in the carrier refusing to honor a damage claim. The form required to file such a claim will be supplied by the carrier.

Reporting Concealed Damage

Concealed damage means damage which does not become apparent until the unit has been unpacked. The contents may be damaged in transit due to rough handling, even though the carton may not show external damage. If you discover damage after unpacking the unit, make a written request for an inspection by the carrier's agent, then file a claim with the carrier since such damage is most likely the carrier's responsibility.

Inventory Equipment Received

After opening your shipment, an inventory of the parts should occur immediately. Check each item received in your shipment against the packing slip included with the shipment. If any items are missing, please notify Andrew Corporation immediately by contacting the Customer Service Center.

Returning Equipment

Andrew Corporation tries to ensure that all items arrive safe and in working order. Occasionally, despite these efforts, equipment is received which is not in working condition. When this occurs, and it is necessary to return the equipment to Andrew Corporation for either repair or replacement, return can be expedited by following the procedure listed below:

Step 1

Call the Andrew Customer Service Center and request a Return Material Authorization (RMA) number, as well as an address to forward the material to.

Step 2

Tag or identify the defective equipment, noting the defect or circumstances. Also, be sure to write the RMA number on the tag. It would be helpful to reference the sales order and purchase order, as well as the date the equipment was received.

Step 3

Pack the equipment in its original container with protective packing material. If the original container and packing material are no longer available; pack the equipment in a sturdy corrugated box, and cushion it with appropriate packing material.

Step 4

Be sure to include the following information when returning the equipment:

- Your Company Name
- Your Company Address
- City, State, and Zip Code
- Telephone Number
- RMA Number
- Problem Description
- Contact Name

NOTE: Absence of the RMA number will cause a delay in processing your equipment for repair. Be sure to include the RMA number on all correspondence.

Step 5

Ship the equipment to Andrew Corporation using UPS, U.S. Postal Service, or other appropriate carrier; freight prepaid and insured. The material should be forwarded to the address given by the Andrew contact in Step 1.

Installation Procedures

Overview

This section provides installation procedures for the 5.6-Meter Andrew Earth Station Antenna. The installation procedures include instructions on the following antenna components:

- Mount
- Reflector
- Enclosure
- Reflector-to-Mount Assembly
- Subreflector
- Feed System (C-, X- and Ku-band)

Foundation Preparation

Before beginning the installation process on the ground mount assembly, ensure that the foundation has been prepared. Foundation specifications are provided by Andrew and may be used as a reference by civil engineering personnel when preparing the foundation for local soil conditions. These specifications are available before the shipment arrives by contacting the Customer Service Center or your Account Manager.

- Foundation should be dimensioned as detailed in Figure 1.
- Sweep foundation clear of any dirt or debris.
- To ensure smooth surface for mount, scrape foundation pads as shown in Figure 2.
- Studs should extend 3 in. above the ground and are 7/8 in. in diameter
- Apply stick wax to stud threads to ease later connections.

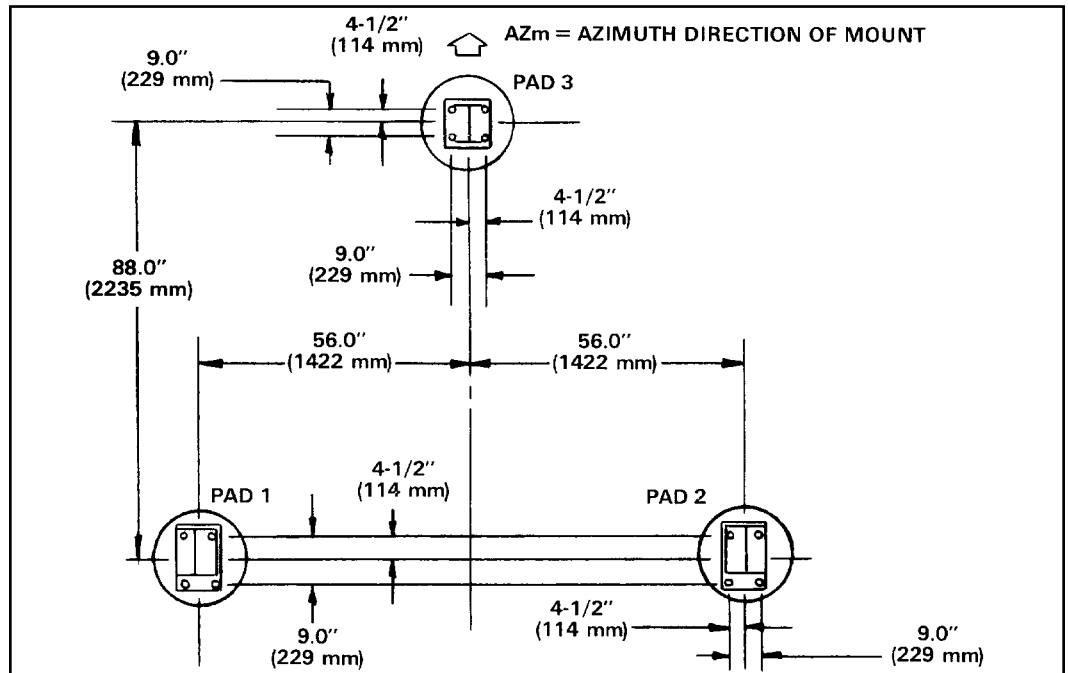

Figure 1



Figure 2

A-325 Tensioning

During the installation process, there are several references to the A-325 hardware tensioning procedure. The A-325 hardware must be properly tensioned to avoid slippage between bolted surfaces under high loads. Slippage can cause the corresponding assembly to move, causing antenna misalignment. When designated, the A-325 hardware should be tightened according to the following tensioning procedure.

NOTE: Tensioned bolts are for final connections only and should not be loosened for reuse.

- Step 1** Lubricate the bolt threads with the provided stick wax to reduce friction.
- Step 2** Insert the bolt, and add a flat washer—if required. **Do not** allow wax under the flat washer.
- Step 3** Add the nut, and finger tighten.
- Step 4** After the connections are complete, tighten the bolts until the surfaces are joined and the nuts are snug (for example, full effort of a person using an ordinary spud wrench). Do not proceed with Steps 5 and 6, unless the connection is final and is not intended to be loosened again.
- Note:** If the bolts are loosened after Steps 5 and 6, discard and replace with new hardware.
- Step 5** Using a felt-tip marker, mark the nuts and the ends of the bolts with a straight line as shown in Figure 3-1a and Figure 3-1b.
- Step 6** Tighten the nuts further with an extra long wrench until the nuts are moved 1/3 turn (120 degrees) as shown in **Figure 3-1a** for bolt lengths less than four diameters and 1/2 turn (180 degrees) as shown in **Figure 3-1b** for bolt lengths over four diameters.

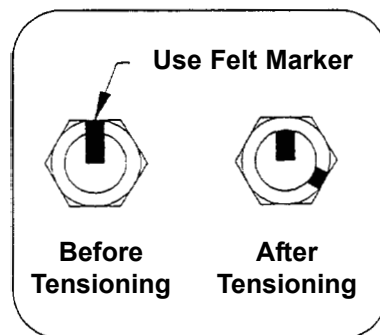

Figure 3-1a: A-325 Tensioning Procedure For bolts less than 4 diameters

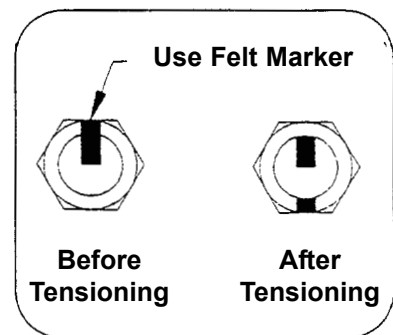

Figure 3-1b: A-325 Tensioning Procedure For bolts over 4 diameters

Tripod Ground Mount Assembly

The three-point mount is an elevation-over-azimuth mount optimized for geostationary satellite applications. The mount enables continuous elevation adjustment from 0 to 90°. Azimuth adjustment is $\pm 90^\circ$ and divided into three 120° ranges with 30° overlap. Follow the subsequent procedures for proper installation of tripod ground mount assembly.

Azimuth Beam Assembly

Step 1

All ground mount hardware is type A-325. Lubricate all A325 bolt threads with supplied stick wax. **Note:** Do not tighten hardware until ground mount installation is complete unless otherwise instructed.

Step 2

Attach 200056 and 200057 supports to upper portion of 201408 beam assembly as shown in Figure 3.

- Use 7/8 x 2-1/4 in (57 mm) hardware

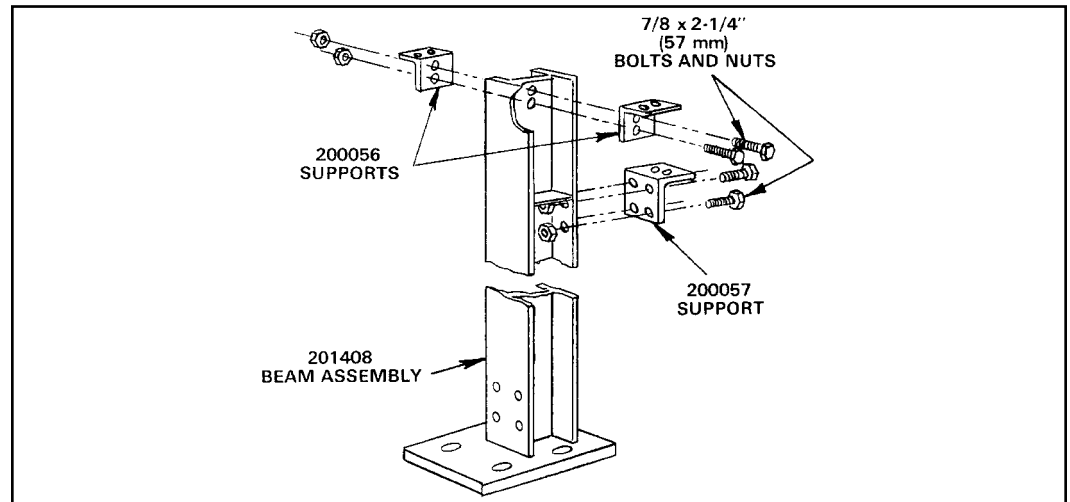

Figure 3

Step 3

Raise 201408 azimuth beam assembly and attach to front foundation pad as shown in Figure 4.

- Use 7/8 in. flatwashers and hex nuts

Note: Hex nuts and flatwashers supplied with 201630 anchor bolt kit

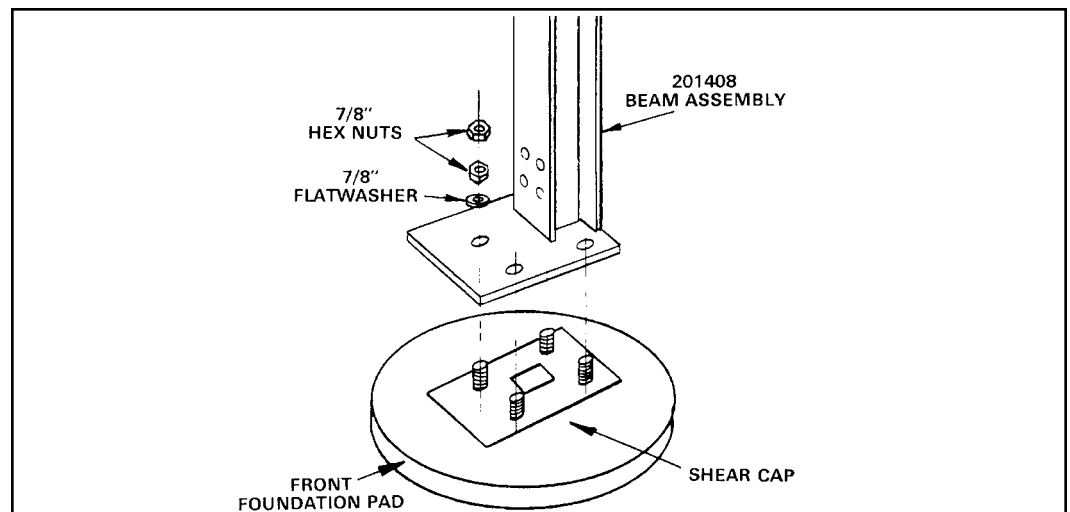

Figure 4

Support Legs Assembly

Step 1

Attach 201327 joint assembly to 201313 beam assembly as shown in Figure 5. Attach 200083 angles to 201313 beam assembly as shown in Figure 5.

- Use 7/8 x 2-1/4 in (57 mm) bolts and nuts for each connection

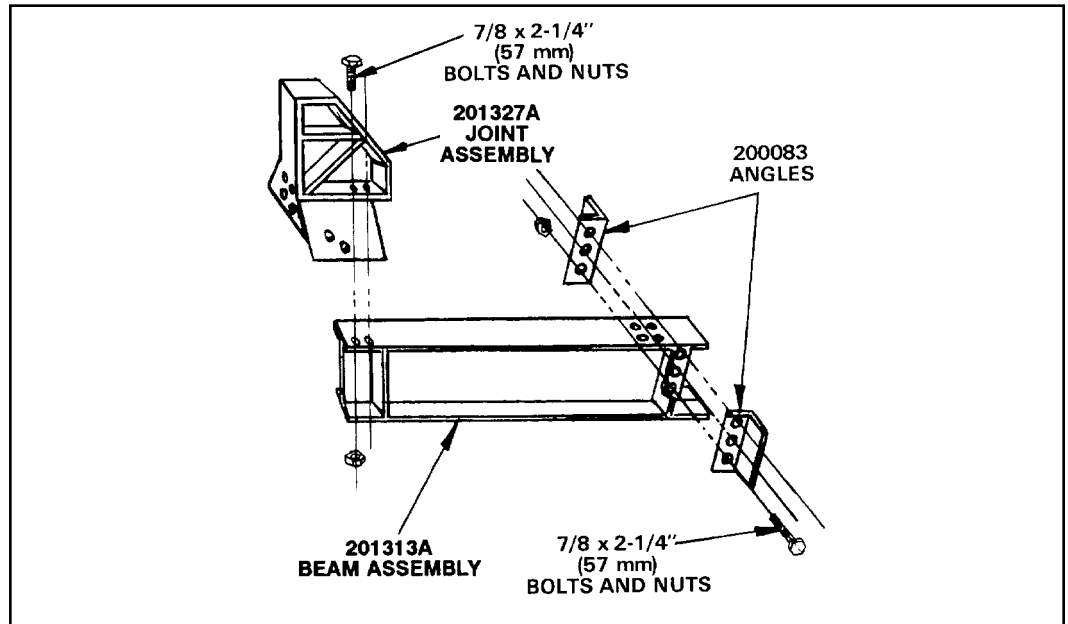

Figure 5

Step 2

Attach 200088 joint assembly to 201313 beam assembly as shown in Figure 6.

- Use 7/8 x 2-1/4 in (57 mm) bolts and nuts

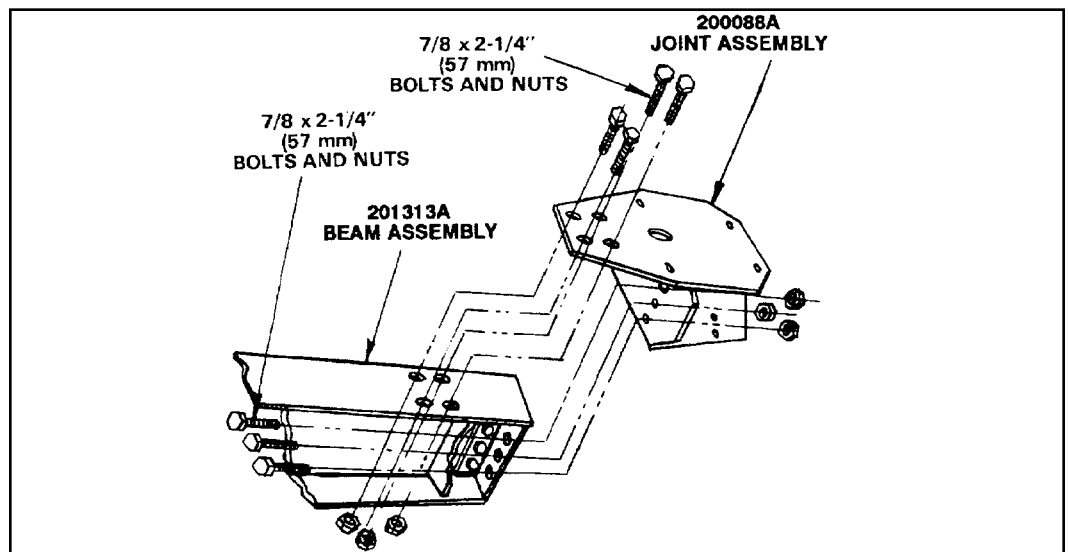

Figure 6

Step 3

Raise 201313 beam assembly to upright position and attach 201315 supports to 201327A joint assembly as shown in Figure 7.

- Use 7/8 x 2-1/4 in (57,ivm) bolts and nuts
- Insert bolts from 201327A joint assembly to supports
- Supports should be installed back-to-back with the flat of angle facing upwards
- Tighten supports until assembly can support itself



Figure 7

Step 4

Attach 201301/201302 rear pad assembly to 201315 supports as shown in Figure 8.

- Use 7/8 x 2-1/4 in (57 mm) bolts and nuts
- Insert bolt from inside of rear pad assembly to outside of support
- Supports should be installed back-to-back with the edges forward and the flats of angles facing rear



Figure 8

Step 5

Attach 201314 supports to 201301/201302 rear pad assemblies and 201273 joint assembly as shown in Figure 9.

- Use 7/8 x 2-1/4 in (57 mm) bolts and nuts
- Insert bolt from inside of joint assembly to outside of support
- Supports should be installed back-to-back with the edges forward and the flats of angles facing rear



Figure 9

Step 6

Attach 201317 supports between angle pairs as shown in Figure 10. Select corresponding mounting holes so that 201317 supports are parallel to 201313 beam assembly.

- Use 7/8 x 2-1/4 in (57 mm) hardware
- Supports attached with edges inward and flats facing up.

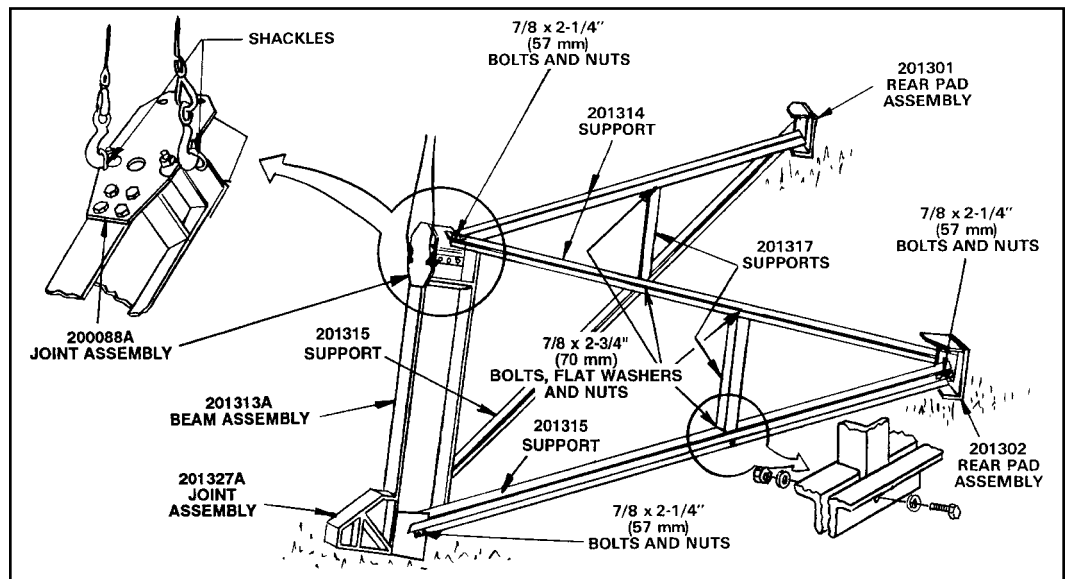

Figure 10

Panning Frame Assembly

Step 1

Attach 201487 panning frame to 201544 azimuth pivot assembly as shown in Figures 11 and 12.

- Use 7/8 x 2-1/4 in (57 mm) hardware
- Bolts should connect from panning frame to pivot assembly



Figure 11

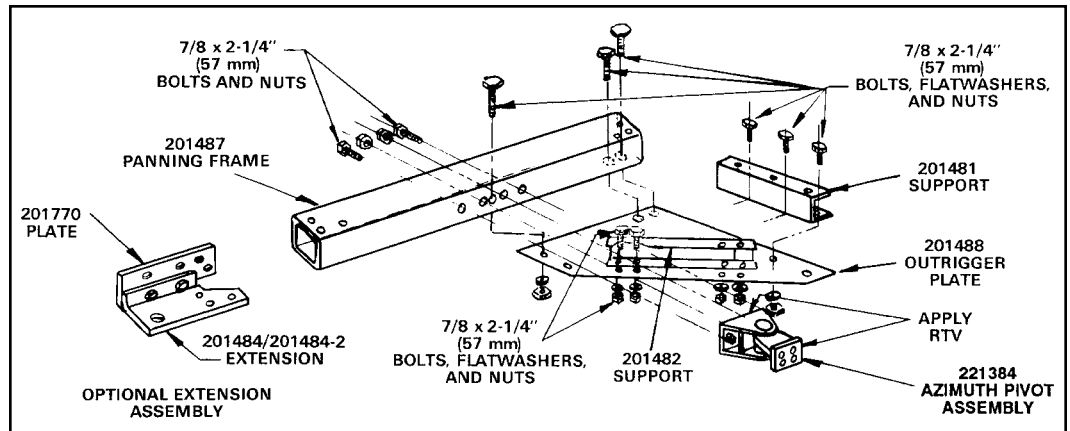

Figure 12

Step 2

Attach 201295/201296 joint assemblies to panning frame as shown in Figures 13 and 14.

- Use 7/8 x 2-1/4 in (57 mm) hardware
- Insert bolts from panning frame to joint assembly



Figure 13

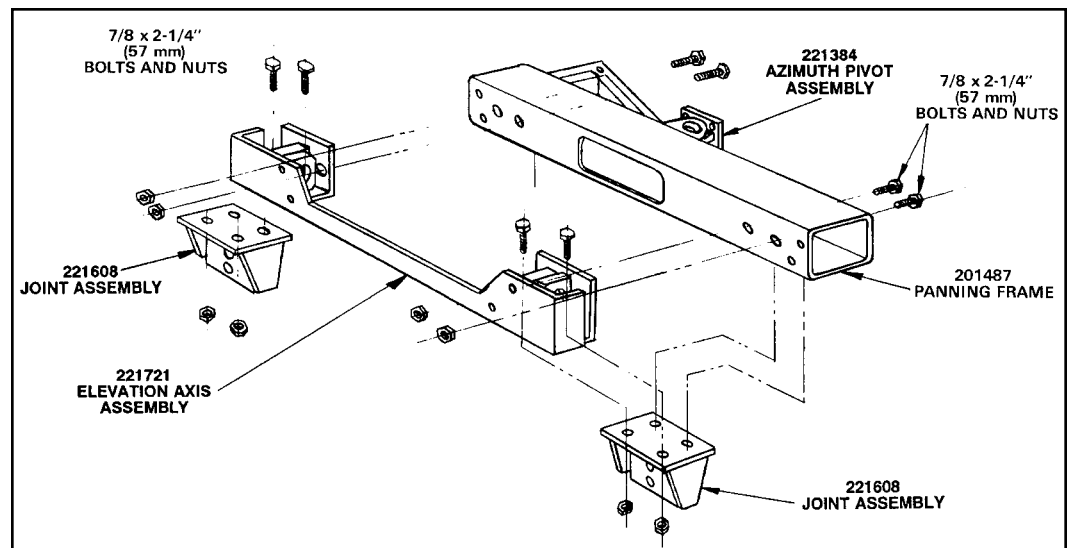

Figure 14

Step 3

Attach 201316 support pairs to 201295/201296 joint assemblies as shown in Figure 15.

- Place supports back-to-back with edges out and flat of angle inward
- Install 45967 spacer at midpoints of support pairs
- Use 7/8 x 2-1/4 in (57 mm) hardware for each connection



Figure 15

Step 4

Attach 201458 azimuth pivot assembly to 201316 support pairs. Attach 201596 mounting plates to 201458 azimuth pivot assembly tab as shown in Figure 16.

- Use 7/8 x 2-1/4 in (57 mm) hardware for each connection
- Insert bolts from rear of pivot assembly to connect supports



Figure 16

Step 5

Attach 201770 plate connecting 201484/201484-2 extension assembly to 201487 panning frame as pictured in Figure 17.

- Use 7/8 x 2-1/4 in (57 mm) hardware
- Insert bolts from inside panning frame assembly

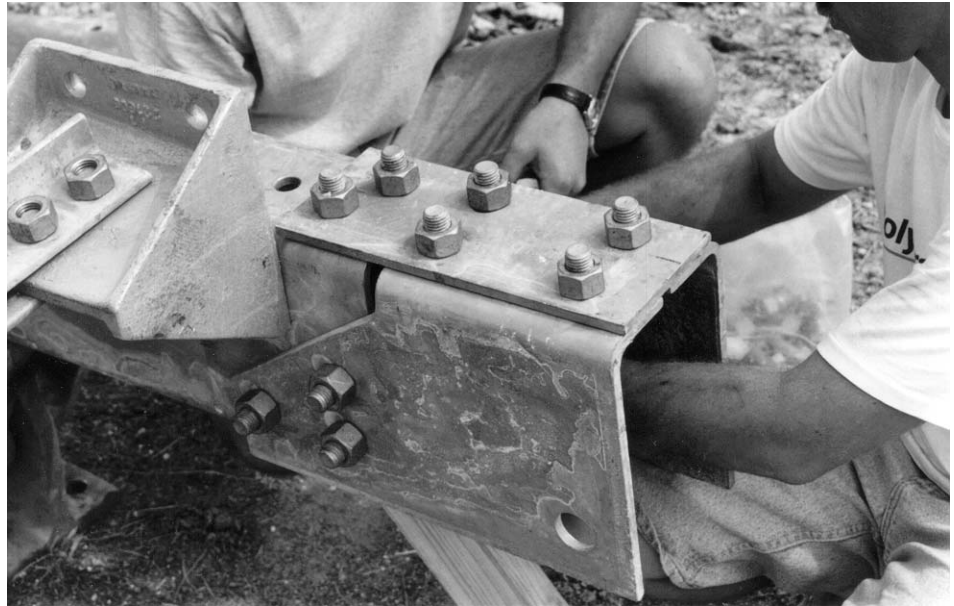

Figure 17

Step 6

Attach 201488 outrigger plate to opposite end of 201487 panning assembly. Attach 201481/201482 supports to outrigger plate as shown in Figure 18.

- Use 7/8 x 2-1/4 in (57 mm) hardware
- Insert bolts from supports to the outrigger plate



Figure 18

Step 7

Attach second 201488 outrigger plate to 201487 panning frame assembly as shown in Figure 19.

- Use 7/8 x 2-1/4 in (57 mm) hardware
- Insert bolts from inside assembly to outrigger plate



Figure 19

Step 8

Attach 201407 elevation axis assembly to 201487 panning frame assembly and 201295 joint assemblies as shown in Figures 20 and 21.

- Use 7/8 x 2-1/4 in (57 mm) hardware
- Insert bolts from elevation axis assembly to panning frame assembly and joint assembly



Figure 20

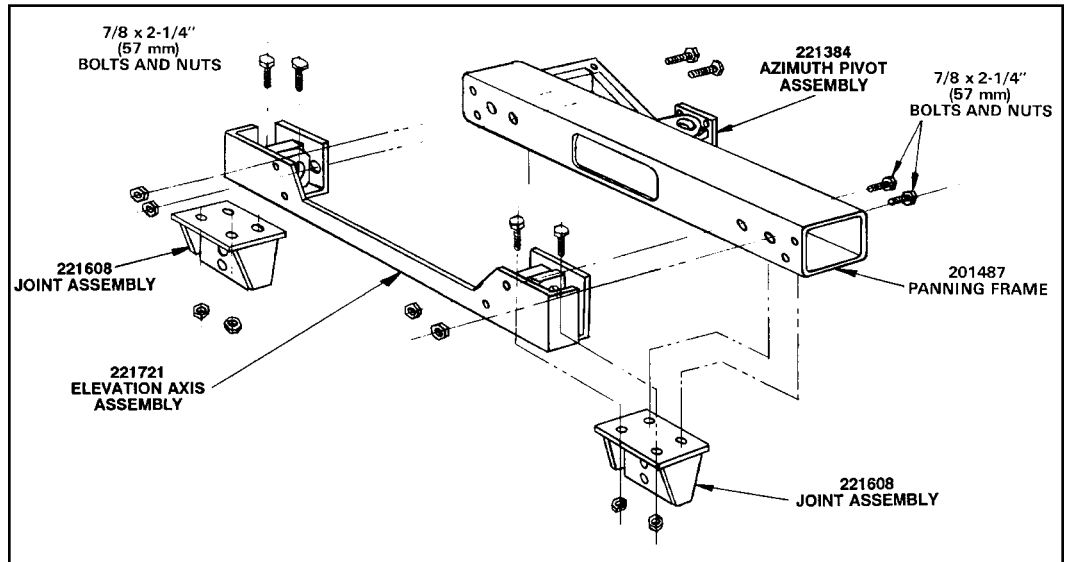

Figure 21

Step 9

Attach 300029 tripod joint bracket to 201407 elevation axis assembly as shown in Figure 22.

- Use 7/8 x 2-1/4 in (57 mm) bolt, flatwasher under bolt and under nut, and nut
- Insert bolts from elevation axis assembly to tripod joint bracket



Figure 22

Step 10

Attach 300026 tripod channel legs to 300029 tripod joint bracket as shown in Figure 23.

- Use 7/8 x 2-1/4 in (57 mm) bolt, flatwasher and nut
- Insert bolts from channel leg to joint bracket



Figure 23

Step 11

Attach 300010 tripod tube weldment to 300026 tripod channel legs as shown in Figure 24.

- Use 7/8 x 2-1/4 in (57 mm) bolt, flatwasher and nut
- Insert bolt from channel leg to tube weldment



Figure 24

**Elevation
Jackscrew
Assembly
Step 1**

Attach 301771/301736 elevation jackscrew assembly to 201596 mounting plates as shown in Figure 25. Tighten connection.

- Use 7/8 x 2-1/2 bolts and nuts



Figure 25

Step 2

Loosen rubber boot from end of jackscrew. Turn elevation drive screw to extend jack to dimension 67.7 in (1719 mm) as shown in Figure 26. Apply grease to screw shaft. Reattach rubber boot.



Figure 26

Step 3

Prop 301771/301736 elevation jackscrew up to align with 300010 tripod tube weldment as shown in Figure 27.



Figure 27

Step 4

Attach 301771/301736 elevation jackscrew to 300010 tripod tube weldment as shown in Figure 28.

- Use 7/8 x 5-1/4 (133 mm) bolt. Fasten with heavy hex nut and flatwasher according to A-325 procedure with the exception of tightening the nut 1/2 turn from snug condition. Tighten jam nut in accordance with A-325 procedure. Apply supplied Loctite to threads to act as locking nut.



Figure 28

Azimuth Jackscrew Assembly

Step 1

Insert 22193/223180 azimuth jackscrew tube into 201287 azimuth pivot assembly as shown in Figure 29. Insert jack carefully to prevent scratching jackscrew tube. **Note:** Ensure jackscrew assembly remains fully retracted at this time.

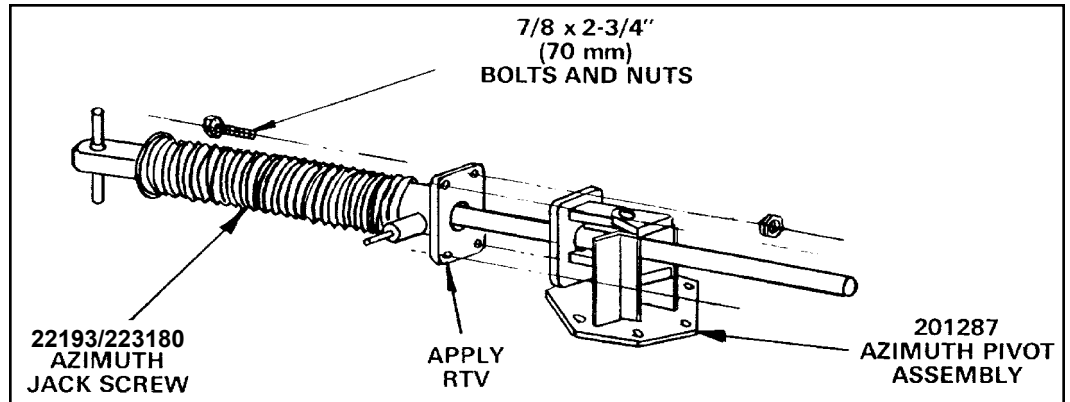

Figure 29

Step 2

Apply RTV to flange surface as shown in Figure 29. Fasten jack to pivot using 7/8 x 2-3/4 in (70 mm) bolts and nuts. Mounting hardware is included with corresponding jack assembly hardware kit.

Mount Assembly

Step 1

Attach shackles to beam assembly as shown in Figure 30.



Figure 30

Step 2

Lift support legs to azimuth beam assembly.

Step 3 Attach rear pad assemblies to rear foundation pads as pictured in Figure 31.

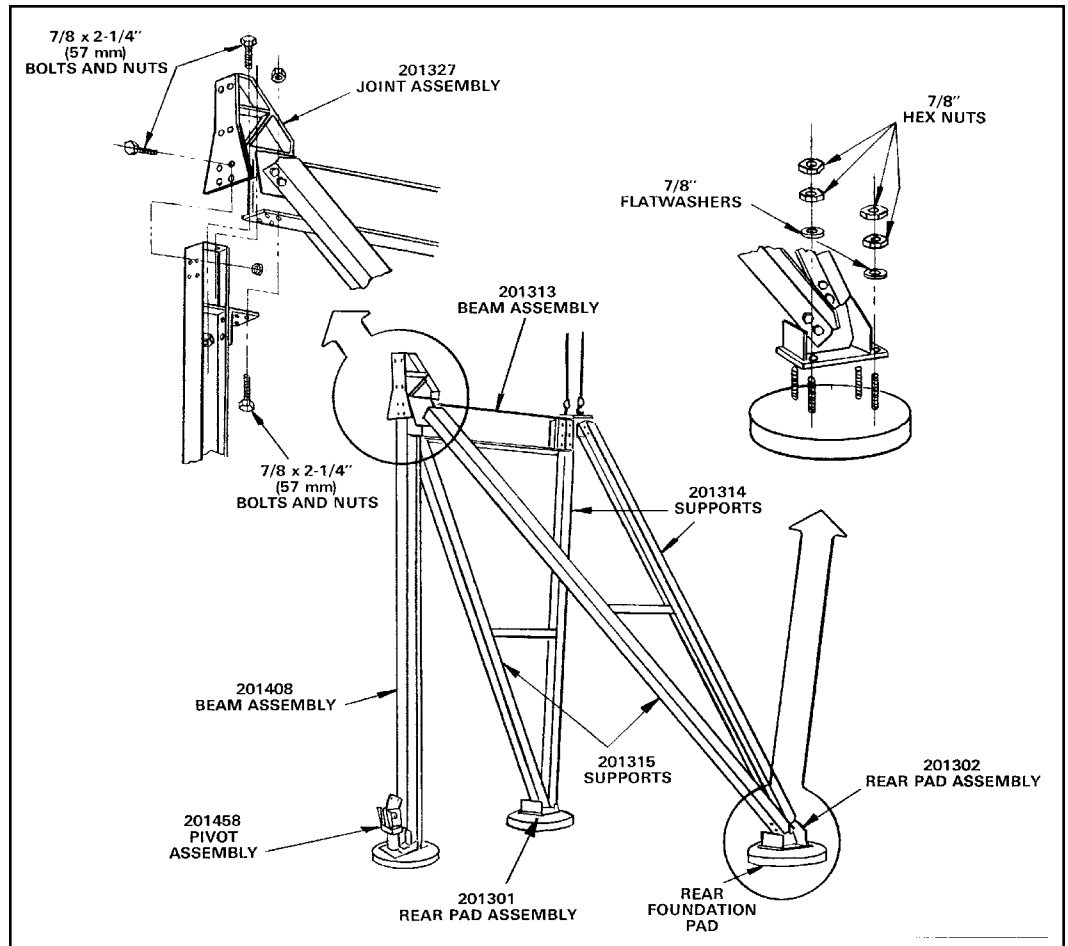

Figure 31

Step 4 Connect beam assembly using 7/8 x 2-1/4 in (57 mm) hardware. Tighten supports to beam assembly per A-325 tensing procedure.

Step 5

Hoist elevation jackscrew assembly to mount. Attach 201544 azimuth pivot assembly to 201327 joint assembly with 7/8 x 2-1/4 hardware from pivot assembly to joint assembly as shown in Figure 32.

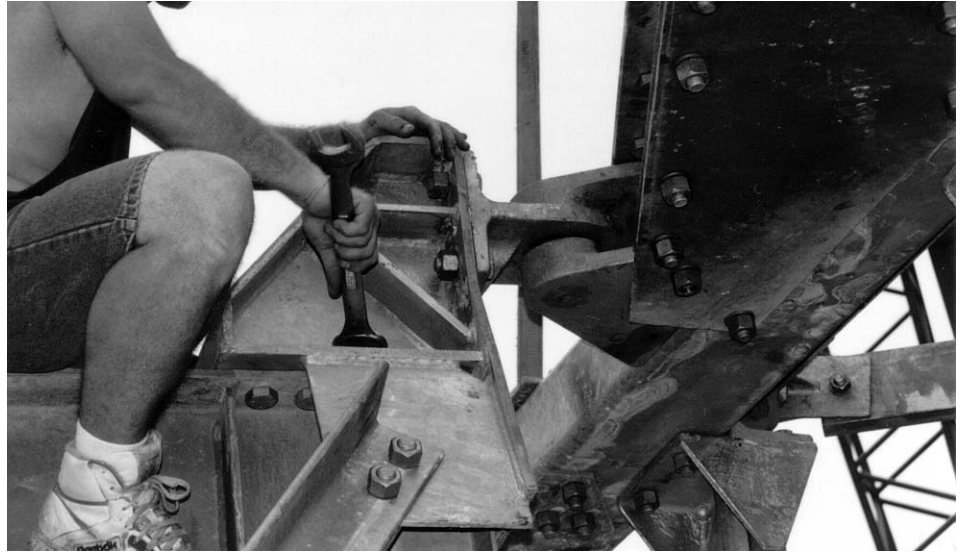

Figure 32

Step 6

Attach 201458 azimuth pivot assembly to 201408 beam assembly with a line of RTV around the plate and four 7/8 x 2-1/4 in (57 mm) bolts inserted from pivot assembly to beam assembly as shown in Figure 33.

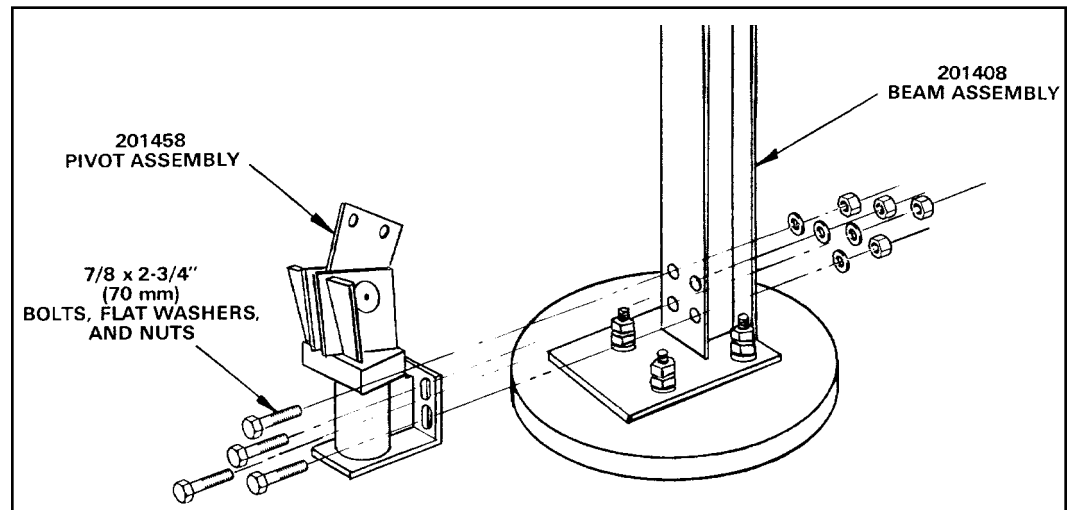

Figure 33

Note: If optional motor drive system is included, install motors at this point. Refer to installation instructions provided with motor kits.

Step 7

Refer to Figure 34. Position hoisting ropes on azimuth motor jack assembly so jack will not roll when hoisted. Attach one rope to motor frame next to gearbox to balance assembly. Tie up loose conduit before lifting jack.



Figure 34

Step 8

Refer to Figure 34. Position hoisting ropes on motor/jack assembly so jack will not roll when hoisted. Attach one rope to large motor frame next to gearbox to balance assembly; do not attach rope to small motor. Tie up loose conduit before lifting jack.

Step 9

Raise 22193/223180 azimuth jackscrew and attach 201287 pivot assembly to 201273 joint assembly with 1 x 2-1/2 in (63 mm) hardware. **Note:** Mounting position of azimuth pivot jackscrew assembly is dependent upon azimuth range requirements and corresponds with mounting position of 201488 outrigger plate or extension assembly.

Step 10

Extend jackscrew to meet outrigger assembly. Loosely re-attach outrigger plate to pin assembly in azimuth jackscrew as shown in Figure 35. **Note:** Realignment of panning frame/pivot assembly may be necessary to ensure proper alignment of azimuth jackscrew pin. Snug panning frame/pivot assembly hardware and fully extend azimuth jackscrew to ensure binding does not occur throughout entire azimuth pivot range.

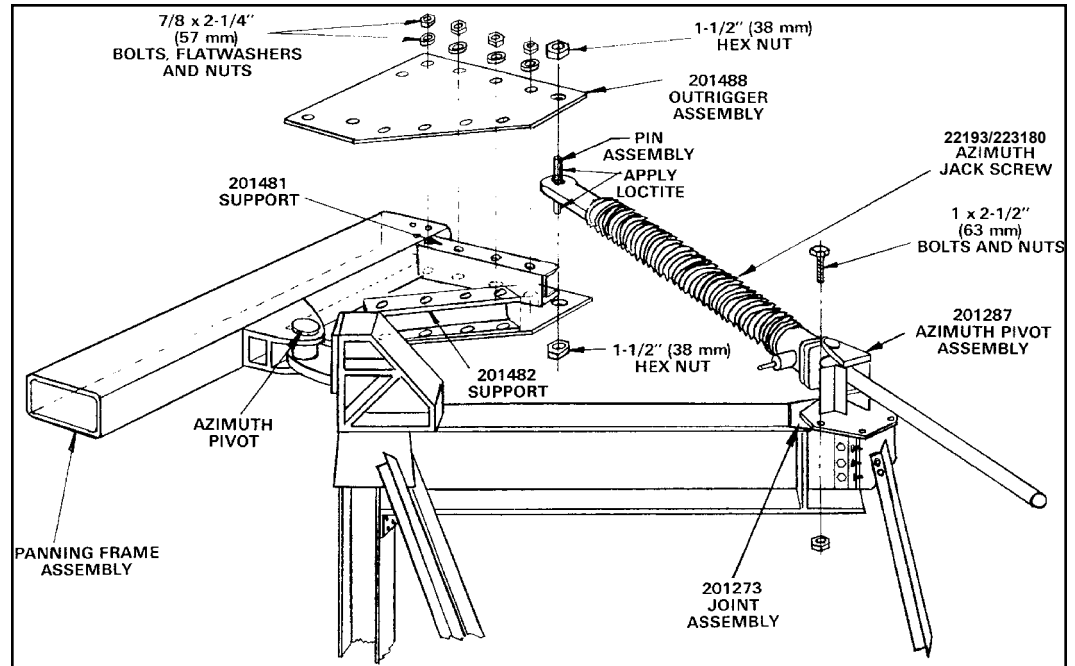

Figure 35

Step 11

Loosen both setscrews in upper and lower collars of pin assembly at end of azimuth jack. **Do not retighten these collars.** Apply supplied Loctite to pin threads and nuts. Attach 1-1/2 in (38 mm) hex nuts to top and bottom of azimuth jackscrew pin assembly and securely tighten mounting hardware using 6 foot (1.8 m) lever arm. Reattach rubber boot. Tighten an outrigger plate hardware.

The tripod ground mount assembly is now completed with the necessary operational essentials. All ground mount options have separate instructional bulletins located in the parts kit that contain the option.

The next step in the installation process is the reflector assembly. Proceed to the next page to begin installation of the reflector.

REV. NO. 239954 1 2 3 4 5 6 7 8

REV. NO.	DATE	BY	REVISIONS
1	01/25/18	MM	ISSUED FOR PRODUCTION
2	02/28/18	MM	BEL TO PRODUCTION
3	03/22/18	MM	ADDED NOTICE BLOCK TO STEP 1. REV'D DIMENSIONS
4	03/22/18	MM	ADDED NOTICE BLOCK TO STEP 5. REV'D DIMENSIONS
5	03/22/18	MM	ZONE A-7. REV'D NOTE CALLOUT (5). DIMENSIONS
6	03/22/18	MM	INCREMENT REV LEVELS TO 00197 CLASS C
7	03/22/18	MM	
8	03/22/18	MM	

NOTES: (UNLESS OTHERWISE SPECIFIED)

1. DIMENSIONS ARE IN INCHES
2. DIMENSIONS ARE IN MILLIMETERS
3. DIMENSIONS ARE IN MILLIMETERS

CAUTION: INSTALL REFLECTOR/BACK STRUCTURE ASSEMBLY ONLY WHEN VIBRS ARE LESS THAN 15 MPH TO PREVENT DAMAGE TO REFLECTOR PANELS AND EASE ASSEMBLY.

STEP 1: PLACE MODULAR ENCLOSURE (ITEM 42) ON FOUR TEMPORARY WOOD SUPPORT BLOCKS. BE CAREFUL TO NOT DAMAGE MACHINED SURFACES. BOLT ON WOOD STRUTS (ITEM 47) TO ENCLOSURE. REFER TO FIGURE 1. FULLY TIGHTEN ALL HARDWARE.

STEP 2: FOR STEPS 1 THRU 4, LUBRICATE BOLT THREADS OF BOTH STAINLESS STEEL AND A325 HARDWARE WITH STICK WAX (ITEM 39) TO REDUCE FRICTION. DO NOT ALLOW WAX UNDER FLATWASHER.

STEP 3: ATTACH TWO LONG STRUTS (ITEM 46) LOOSELY TOGETHER PER VIEW A-A IN FIGURE 1 TO MAKE 16 PAIRS OF STRUTS. ATTACH EACH PAIR OF LONG STRUTS TO SHORT STRUTS USING 0.25 SPACERS (ITEM 2). REFER TO SECTION B-B FIGURE 1.

STEP 4: ATTACH RIBS (ITEM 44) TO SHORT STRUTS (ITEM 47). REFER TO SECTION D-D FIGURE 1. HANDLE RIBS CAREFULLY TO KEEP FROM DISTORTING SHAPE.

STEP 5: RAISE LONG STRUTS (ITEM 46) AND RIB (ITEM 44). ATTACH LONG STRUT TO RIB WITH 0.625 DIA SHOULDER BOLT (ITEM 34) AND 0.625 DIA A325 BOLT (ITEM 23). REFER TO FIGURE 1 VIEW C-C.

STEP 6: MAKE SURE THAT ALL 0.25 SPACERS (ITEM 2) ARE PROPERLY PLACED AND SHOULDER BOLTS ARE PROPERLY SEATED THROUGH ALL CONNECTIONS.

STEP 7: SECURELY TIGHTEN ALL STAINLESS STEEL HARDWARE. NEXT, TIGHTEN ALL A325 HARDWARE FOLLOWING TENSIONING PROCEDURES, SHOWN ON SHEET 1.

VIEW A-A
LONG STRUT MIDDLE CONNECTION (TYPICAL 16 PLACES)

VIEW B-B
LONG STRUT/RIB CONNECTION (TYPICAL 16 PLACES)

VIEW C-C
LONG STRUT/RIB CONNECTION (TYPICAL 16 PLACES)

SECTION D-D
SHORT STRUT/RIB CONNECTION (TYPICAL 16 PLACES)

SECTION B-B
LONG STRUT/SHORT STRUT CONNECTION (TYPICAL 16 PLACES)

FIGURE 1
5.6 M REFLECTOR BACK STRUCTURE INSTALLATION INSTRUCTIONS

NO.	REV.	DATE	BY	APP.	DESCRIPTION
1	1	01/25/18	MM		ISSUED FOR PRODUCTION
2	2	02/28/18	MM		BEL TO PRODUCTION
3	3	03/22/18	MM		ADDED NOTICE BLOCK TO STEP 1. REV'D DIMENSIONS
4	4	03/22/18	MM		ADDED NOTICE BLOCK TO STEP 5. REV'D DIMENSIONS
5	5	03/22/18	MM		ZONE A-7. REV'D NOTE CALLOUT (5). DIMENSIONS
6	6	03/22/18	MM		INCREMENT REV LEVELS TO 00197 CLASS C
7	7	03/22/18	MM		
8	8	03/22/18	MM		

NO.	REV.	DATE	BY	APP.	DESCRIPTION
1	1	01/25/18	MM		ISSUED FOR PRODUCTION
2	2	02/28/18	MM		BEL TO PRODUCTION
3	3	03/22/18	MM		ADDED NOTICE BLOCK TO STEP 1. REV'D DIMENSIONS
4	4	03/22/18	MM		ADDED NOTICE BLOCK TO STEP 5. REV'D DIMENSIONS
5	5	03/22/18	MM		ZONE A-7. REV'D NOTE CALLOUT (5). DIMENSIONS
6	6	03/22/18	MM		INCREMENT REV LEVELS TO 00197 CLASS C
7	7	03/22/18	MM		
8	8	03/22/18	MM		

UNLESS OTHERWISE SPECIFIED

DIMENSIONS ARE IN INCHES

TOLERANCES

1. HOLE DIMENSIONS ± 0.010

2. PLATE DIMENSIONS ± 0.010

3. SPACERS ± 0.005

4. ANGLES ± 0.005

ALL SURFACES

FINISH TO MATCH SURFACES OF PARTS WITH WHICH THEY MATE

ALL DIMENSIONS ARE TO CENTER UNLESS OTHERWISE SPECIFIED

ITEM NO. 209954 **USED ON** REFLECTOR

REVISED DATE 03/22/18 **USED ON** REFLECTOR

APPLICATION REFLECTOR

PARTS LIST

NO.	REV.	DATE	BY	APP.	DESCRIPTION
1	1	01/25/18	MM		ISSUED FOR PRODUCTION
2	2	02/28/18	MM		BEL TO PRODUCTION
3	3	03/22/18	MM		ADDED NOTICE BLOCK TO STEP 1. REV'D DIMENSIONS
4	4	03/22/18	MM		ADDED NOTICE BLOCK TO STEP 5. REV'D DIMENSIONS
5	5	03/22/18	MM		ZONE A-7. REV'D NOTE CALLOUT (5). DIMENSIONS
6	6	03/22/18	MM		INCREMENT REV LEVELS TO 00197 CLASS C
7	7	03/22/18	MM		
8	8	03/22/18	MM		

NO.	REV.	DATE	BY	APP.	DESCRIPTION
1	1	01/25/18	MM		ISSUED FOR PRODUCTION
2	2	02/28/18	MM		BEL TO PRODUCTION
3	3	03/22/18	MM		ADDED NOTICE BLOCK TO STEP 1. REV'D DIMENSIONS
4	4	03/22/18	MM		ADDED NOTICE BLOCK TO STEP 5. REV'D DIMENSIONS
5	5	03/22/18	MM		ZONE A-7. REV'D NOTE CALLOUT (5). DIMENSIONS
6	6	03/22/18	MM		INCREMENT REV LEVELS TO 00197 CLASS C
7	7	03/22/18	MM		
8	8	03/22/18	MM		

DATE: 11/14/00
DRAWN BY: JAW/STP
CHECKED BY: JAW/STP

PROJECT: 239352

REVISIONS

NO.	REV.	DESCRIPTION	DATE	BY
1		BEL TO PRODUCTION	11/14/00	JAW
2		A. ADDED NOTICE BLOCK TO STEP 7. IT IS CALLOUT WAS 0.312-18UNCX 0.75 LG BOLT. I.		
3		B. TIME P. 2 AND P. 3. ADDED LOCKWASHER (ITEM 42) AND LOCKWASHER (ITEM 43). I.		
4		C. INCONSISTENT REV. LEG. DCD 300157 CLASS C. I.		

PROJECT: 239352

DRAWING NO: 101

REV: 1

PARTS LIST

QTY	ITEM	DESC	UNIT	REMARKS
4	32	REFLECTOR PANEL	EA	
4	33	LIFTING TAB	EA	
18	18	0.312-18UNCX 0.75 LG BOLT	EA	
4	43	LOCKWASHER	EA	
1	44	RIB	EA	
4	45	SKIRT	EA	

NOTES: (UNLESS OTHERWISE SPECIFIED)

1. DIMENSIONS ARE IN INCHES
2. DIMENSIONS ARE IN FEET
3. DIMENSIONS ARE IN FEET
4. DIMENSIONS ARE IN FEET

STEP 6:
WHILE ON THE GROUND ATTACH STRETCH-FORMED SKIRTS (ITEM 45) TO REFLECTOR PANELS (ITEM 43). REFER TO SECTION G-G.

STEP 7:
ATTACH THE REFLECTOR PANELS TO EACH SET OF RIBS BY LOOSELY ATTACHING SEAM HARDWARE (ITEMS 4 AND 52). PANELS SHOULD BE ADDED OPPOSITE EACH OTHER. TO BALANCE THE ENCLOSURE ASSEMBLY, FIRST ATTACH PANELS TO THE ENCLOSEMENT ASSEMBLY AND PANEL 4, AND SO ON REFER TO VIEW F-F, SHEET 4.

NOTICE

DIFFERENT LENGTH HARDWARE IS USED ON THE OUTERMOST SEAM CONNECTION (SEE SECTION G-G AND VIEW K-K ON SHEET 4).

STEP 8:
LOOSELY ATTACH SKIRT STRAPS (ITEM 1). REFER TO VIEW K-K, SHEET 4. TABS (ITEM 32), LOCATED ON THE SECOND AND THIRD SEAM HOLES OF THE PANEL 90° APART FROM EACH OTHER (4 REQUIRED). REFER TO FIGURE 2 AND VIEW F-F, SHEET 4 FOR PROPER ORIENTATION.

CAUTION: DURING OVERNIGHT OR HIGH-WIND CONDITIONS, UNLATCHED RIBS CAN BE WIND-LOADED. MAKE TAG LINES AT PLACES APPROXIMATELY 90° TO EACH OTHER. REFER TO FIGURE 2.

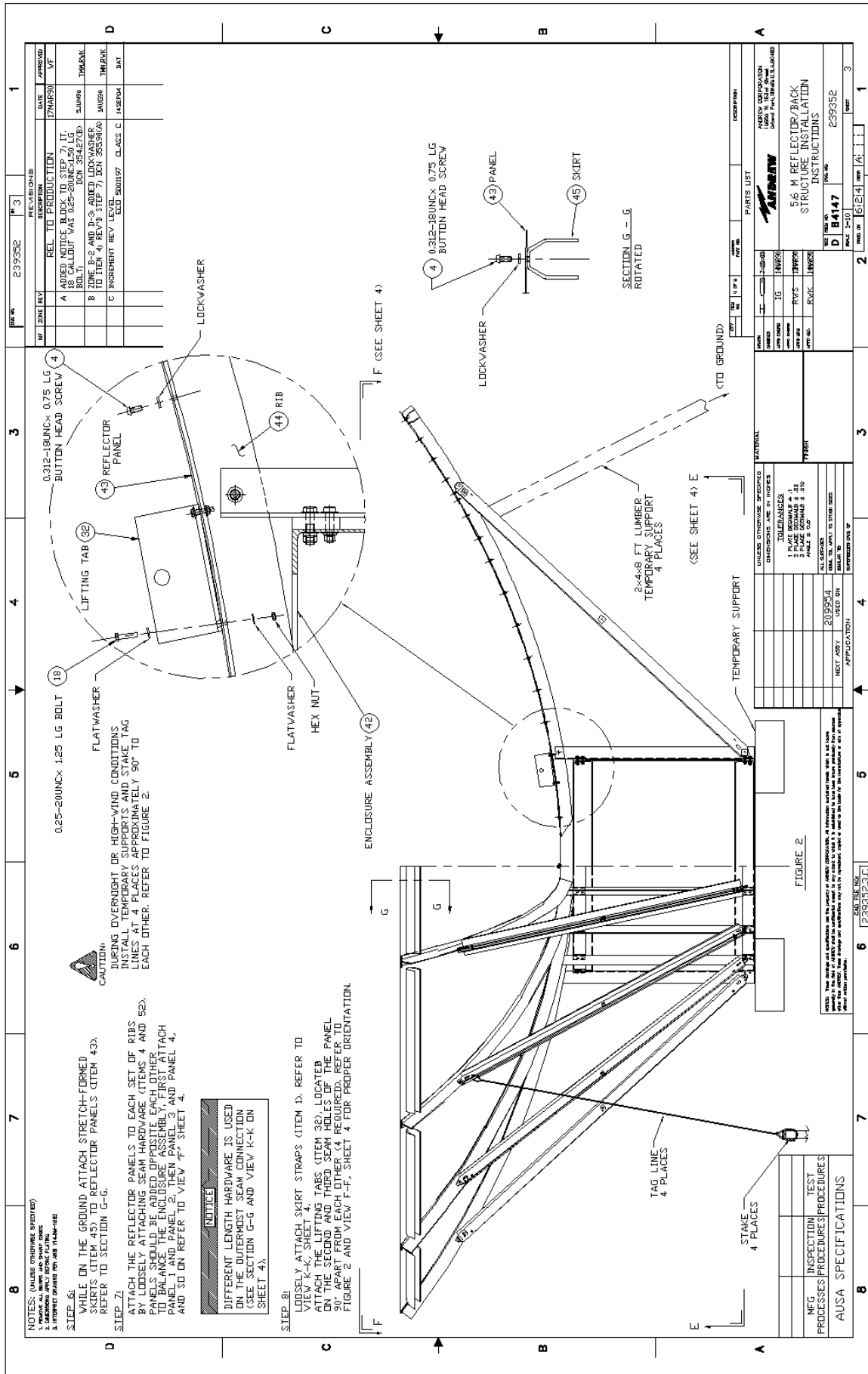

FIGURE 2

5/6 M REFLECTOR/BACK STRUCTURE INSTALLATION INSTRUCTIONS

DRAWING NO: B4147

REV: 3

DATE: 11/14/00

UNLESS OTHERWISE SPECIFIED, DIMENSIONS ARE IN INCHES.

TOLERANCES:

1. PLATE DIMENSIONS ± .010

2. DIMENSIONS ± .015

3. DIMENSIONS ± .015

4. DIMENSIONS ± .015

ALL DIMENSIONS TO CENTER UNLESS NOTED OTHERWISE.

DATE: 11/14/00 BY: JAW/STP

DRAWING NO: 239352

APPLICATION:

STAKE 4 PLACES

TAG LINE 4 PLACES

TEMPORARY SUPPORT

2x4x8 FT LUMBER TEMPORARY SUPPORT 4 PLACES

(SEE SHEET 4) E

ENCLOSURE ASSEMBLY (42)

FLATWASHER

HEX NUT

LIFTING TAB (32)

REFLECTOR PANEL (43)

0.312-18UNCX 0.75 LG BOLT (4)

LOCKWASHER

RIB (44)

SKIRT (45)

PANEL (43)

LOCKWASHER

0.312-18UNCX 0.75 LG BUTTON HEAD SCREW

SECTION G-G ROTATED

TO GROUND

8	7	6	5	4	3	2	1																
<p>REV. NO. 239352</p> <table border="1" style="width: 100%; border-collapse: collapse;"> <tr> <th>REV. NO.</th> <th>DATE</th> <th>APPROVED</th> </tr> <tr> <td>1</td> <td>17MAY95</td> <td>WF</td> </tr> </table>								REV. NO.	DATE	APPROVED	1	17MAY95	WF										
REV. NO.	DATE	APPROVED																					
1	17MAY95	WF																					
<p>REVISIONS</p> <table border="1" style="width: 100%; border-collapse: collapse;"> <tr> <th>NO.</th> <th>DESCRIPTION</th> <th>DATE</th> <th>APPROVED</th> </tr> <tr> <td>1</td> <td>REL TO PRODUCTION</td> <td>17MAY95</td> <td>WF</td> </tr> <tr> <td>2</td> <td>A INCREMENT REV. CLASS C</td> <td>14SEP04</td> <td>DAT</td> </tr> <tr> <td>3</td> <td>ECD 5001157</td> <td></td> <td></td> </tr> </table>								NO.	DESCRIPTION	DATE	APPROVED	1	REL TO PRODUCTION	17MAY95	WF	2	A INCREMENT REV. CLASS C	14SEP04	DAT	3	ECD 5001157		
NO.	DESCRIPTION	DATE	APPROVED																				
1	REL TO PRODUCTION	17MAY95	WF																				
2	A INCREMENT REV. CLASS C	14SEP04	DAT																				
3	ECD 5001157																						
<p>NOTES: (UNLESS OTHERWISE SPECIFIED)</p> <ol style="list-style-type: none"> 1. DIMENSIONS ARE IN INCHES 2. DIMENSIONS ARE IN MILLIMETERS 3. DIMENSIONS ARE IN MILLIMETERS <p>STEP 2:</p> <p>CHECK REFLECTOR PANEL FITS. INSURE THAT SEAM WIDTHS ARE UNIFORM AND PANELS OVERLAP. NO. TIGHTENING REFLECTOR PANEL HARDWARE FROM THE INSIDE. TIGHTEN REFLECTOR MOST HOLES. TIGHTEN SKIRT STRAP HARDWARE.</p> <div style="border: 1px solid black; padding: 2px; width: fit-content;"> <p>NOTICE</p> <p>CHECK TO SEE THAT ALL REFLECTOR HARDWARE IS NOW SECURELY TIGHTENED.</p> </div>																							
<div style="display: flex; justify-content: space-between;"> <div style="width: 45%;"> </div> <div style="width: 45%; text-align: center;"> <p>VIEW K-K</p> </div> </div>																							
<div style="display: flex; justify-content: space-between;"> <div style="width: 45%;"> </div> <div style="width: 45%; text-align: center;"> <p>VIEW F-F</p> <p>(FRONT VIEW OF REFLECTOR/BACK STRUCTURE ASSEMBLY)</p> </div> </div>																							
<div style="display: flex; justify-content: space-between;"> <div style="width: 45%;"> </div> <div style="width: 45%; text-align: center;"> <p>VIEW E-E</p> <p>(REAR VIEW OF REFLECTOR/BACK STRUCTURE ASSEMBLY)</p> </div> </div>																							
<table border="1" style="width: 100%; border-collapse: collapse;"> <tr> <th>REV. NO.</th> <th>DATE</th> <th>APPROVED</th> <th>DESCRIPTION</th> </tr> <tr> <td>1</td> <td>17MAY95</td> <td>WF</td> <td></td> </tr> </table>								REV. NO.	DATE	APPROVED	DESCRIPTION	1	17MAY95	WF									
REV. NO.	DATE	APPROVED	DESCRIPTION																				
1	17MAY95	WF																					
<table border="1" style="width: 100%; border-collapse: collapse;"> <tr> <th>REV. NO.</th> <th>DATE</th> <th>APPROVED</th> <th>DESCRIPTION</th> </tr> <tr> <td>1</td> <td>17MAY95</td> <td>WF</td> <td></td> </tr> </table>								REV. NO.	DATE	APPROVED	DESCRIPTION	1	17MAY95	WF									
REV. NO.	DATE	APPROVED	DESCRIPTION																				
1	17MAY95	WF																					
<table border="1" style="width: 100%; border-collapse: collapse;"> <tr> <th>REV. NO.</th> <th>DATE</th> <th>APPROVED</th> <th>DESCRIPTION</th> </tr> <tr> <td>1</td> <td>17MAY95</td> <td>WF</td> <td></td> </tr> </table>								REV. NO.	DATE	APPROVED	DESCRIPTION	1	17MAY95	WF									
REV. NO.	DATE	APPROVED	DESCRIPTION																				
1	17MAY95	WF																					
<table border="1" style="width: 100%; border-collapse: collapse;"> <tr> <th>REV. NO.</th> <th>DATE</th> <th>APPROVED</th> <th>DESCRIPTION</th> </tr> <tr> <td>1</td> <td>17MAY95</td> <td>WF</td> <td></td> </tr> </table>								REV. NO.	DATE	APPROVED	DESCRIPTION	1	17MAY95	WF									
REV. NO.	DATE	APPROVED	DESCRIPTION																				
1	17MAY95	WF																					
<table border="1" style="width: 100%; border-collapse: collapse;"> <tr> <th>REV. NO.</th> <th>DATE</th> <th>APPROVED</th> <th>DESCRIPTION</th> </tr> <tr> <td>1</td> <td>17MAY95</td> <td>WF</td> <td></td> </tr> </table>								REV. NO.	DATE	APPROVED	DESCRIPTION	1	17MAY95	WF									
REV. NO.	DATE	APPROVED	DESCRIPTION																				
1	17MAY95	WF																					
<table border="1" style="width: 100%; border-collapse: collapse;"> <tr> <th>REV. NO.</th> <th>DATE</th> <th>APPROVED</th> <th>DESCRIPTION</th> </tr> <tr> <td>1</td> <td>17MAY95</td> <td>WF</td> <td></td> </tr> </table>								REV. NO.	DATE	APPROVED	DESCRIPTION	1	17MAY95	WF									
REV. NO.	DATE	APPROVED	DESCRIPTION																				
1	17MAY95	WF																					
<table border="1" style="width: 100%; border-collapse: collapse;"> <tr> <th>REV. NO.</th> <th>DATE</th> <th>APPROVED</th> <th>DESCRIPTION</th> </tr> <tr> <td>1</td> <td>17MAY95</td> <td>WF</td> <td></td> </tr> </table>								REV. NO.	DATE	APPROVED	DESCRIPTION	1	17MAY95	WF									
REV. NO.	DATE	APPROVED	DESCRIPTION																				
1	17MAY95	WF																					
<table border="1" style="width: 100%; border-collapse: collapse;"> <tr> <th>REV. NO.</th> <th>DATE</th> <th>APPROVED</th> <th>DESCRIPTION</th> </tr> <tr> <td>1</td> <td>17MAY95</td> <td>WF</td> <td></td> </tr> </table>								REV. NO.	DATE	APPROVED	DESCRIPTION	1	17MAY95	WF									
REV. NO.	DATE	APPROVED	DESCRIPTION																				
1	17MAY95	WF																					
<table border="1" style="width: 100%; border-collapse: collapse;"> <tr> <th>REV. NO.</th> <th>DATE</th> <th>APPROVED</th> <th>DESCRIPTION</th> </tr> <tr> <td>1</td> <td>17MAY95</td> <td>WF</td> <td></td> </tr> </table>								REV. NO.	DATE	APPROVED	DESCRIPTION	1	17MAY95	WF									
REV. NO.	DATE	APPROVED	DESCRIPTION																				
1	17MAY95	WF																					
<table border="1" style="width: 100%; border-collapse: collapse;"> <tr> <th>REV. NO.</th> <th>DATE</th> <th>APPROVED</th> <th>DESCRIPTION</th> </tr> <tr> <td>1</td> <td>17MAY95</td> <td>WF</td> <td></td> </tr> </table>								REV. NO.	DATE	APPROVED	DESCRIPTION	1	17MAY95	WF									
REV. NO.	DATE	APPROVED	DESCRIPTION																				
1	17MAY95	WF																					
<table border="1" style="width: 100%; border-collapse: collapse;"> <tr> <th>REV. NO.</th> <th>DATE</th> <th>APPROVED</th> <th>DESCRIPTION</th> </tr> <tr> <td>1</td> <td>17MAY95</td> <td>WF</td> <td></td> </tr> </table>								REV. NO.	DATE	APPROVED	DESCRIPTION	1	17MAY95	WF									
REV. NO.	DATE	APPROVED	DESCRIPTION																				
1	17MAY95	WF																					
<table border="1" style="width: 100%; border-collapse: collapse;"> <tr> <th>REV. NO.</th> <th>DATE</th> <th>APPROVED</th> <th>DESCRIPTION</th> </tr> <tr> <td>1</td> <td>17MAY95</td> <td>WF</td> <td></td> </tr> </table>								REV. NO.	DATE	APPROVED	DESCRIPTION	1	17MAY95	WF									
REV. NO.	DATE	APPROVED	DESCRIPTION																				
1	17MAY95	WF																					
<table border="1" style="width: 100%; border-collapse: collapse;"> <tr> <th>REV. NO.</th> <th>DATE</th> <th>APPROVED</th> <th>DESCRIPTION</th> </tr> <tr> <td>1</td> <td>17MAY95</td> <td>WF</td> <td></td> </tr> </table>								REV. NO.	DATE	APPROVED	DESCRIPTION	1	17MAY95	WF									
REV. NO.	DATE	APPROVED	DESCRIPTION																				
1	17MAY95	WF																					
<table border="1" style="width: 100%; border-collapse: collapse;"> <tr> <th>REV. NO.</th> <th>DATE</th> <th>APPROVED</th> <th>DESCRIPTION</th> </tr> <tr> <td>1</td> <td>17MAY95</td> <td>WF</td> <td></td> </tr> </table>								REV. NO.	DATE	APPROVED	DESCRIPTION	1	17MAY95	WF									
REV. NO.	DATE	APPROVED	DESCRIPTION																				
1	17MAY95	WF																					
<table border="1" style="width: 100%; border-collapse: collapse;"> <tr> <th>REV. NO.</th> <th>DATE</th> <th>APPROVED</th> <th>DESCRIPTION</th> </tr> <tr> <td>1</td> <td>17MAY95</td> <td>WF</td> <td></td> </tr> </table>								REV. NO.	DATE	APPROVED	DESCRIPTION	1	17MAY95	WF									
REV. NO.	DATE	APPROVED	DESCRIPTION																				
1	17MAY95	WF																					
<table border="1" style="width: 100%; border-collapse: collapse;"> <tr> <th>REV. NO.</th> <th>DATE</th> <th>APPROVED</th> <th>DESCRIPTION</th> </tr> <tr> <td>1</td> <td>17MAY95</td> <td>WF</td> <td></td> </tr> </table>								REV. NO.	DATE	APPROVED	DESCRIPTION	1	17MAY95	WF									
REV. NO.	DATE	APPROVED	DESCRIPTION																				
1	17MAY95	WF																					
<table border="1" style="width: 100%; border-collapse: collapse;"> <tr> <th>REV. NO.</th> <th>DATE</th> <th>APPROVED</th> <th>DESCRIPTION</th> </tr> <tr> <td>1</td> <td>17MAY95</td> <td>WF</td> <td></td> </tr> </table>								REV. NO.	DATE	APPROVED	DESCRIPTION	1	17MAY95	WF									
REV. NO.	DATE	APPROVED	DESCRIPTION																				
1	17MAY95	WF																					
<table border="1" style="width: 100%; border-collapse: collapse;"> <tr> <th>REV. NO.</th> <th>DATE</th> <th>APPROVED</th> <th>DESCRIPTION</th> </tr> <tr> <td>1</td> <td>17MAY95</td> <td>WF</td> <td></td> </tr> </table>								REV. NO.	DATE	APPROVED	DESCRIPTION	1	17MAY95	WF									
REV. NO.	DATE	APPROVED	DESCRIPTION																				
1	17MAY95	WF																					
<table border="1" style="width: 100%; border-collapse: collapse;"> <tr> <th>REV. NO.</th> <th>DATE</th> <th>APPROVED</th> <th>DESCRIPTION</th> </tr> <tr> <td>1</td> <td>17MAY95</td> <td>WF</td> <td></td> </tr> </table>								REV. NO.	DATE	APPROVED	DESCRIPTION	1	17MAY95	WF									
REV. NO.	DATE	APPROVED	DESCRIPTION																				
1	17MAY95	WF																					
<table border="1" style="width: 100%; border-collapse: collapse;"> <tr> <th>REV. NO.</th> <th>DATE</th> <th>APPROVED</th> <th>DESCRIPTION</th> </tr> <tr> <td>1</td> <td>17MAY95</td> <td>WF</td> <td></td> </tr> </table>								REV. NO.	DATE	APPROVED	DESCRIPTION	1	17MAY95	WF									
REV. NO.	DATE	APPROVED	DESCRIPTION																				
1	17MAY95	WF																					
<table border="1" style="width: 100%; border-collapse: collapse;"> <tr> <th>REV. NO.</th> <th>DATE</th> <th>APPROVED</th> <th>DESCRIPTION</th> </tr> <tr> <td>1</td> <td>17MAY95</td> <td>WF</td> <td></td> </tr> </table>								REV. NO.	DATE	APPROVED	DESCRIPTION	1	17MAY95	WF									
REV. NO.	DATE	APPROVED	DESCRIPTION																				
1	17MAY95	WF																					
<table border="1" style="width: 100%; border-collapse: collapse;"> <tr> <th>REV. NO.</th> <th>DATE</th> <th>APPROVED</th> <th>DESCRIPTION</th> </tr> <tr> <td>1</td> <td>17MAY95</td> <td>WF</td> <td></td> </tr> </table>								REV. NO.	DATE	APPROVED	DESCRIPTION	1	17MAY95	WF									
REV. NO.	DATE	APPROVED	DESCRIPTION																				
1	17MAY95	WF																					
<table border="1" style="width: 100%; border-collapse: collapse;"> <tr> <th>REV. NO.</th> <th>DATE</th> <th>APPROVED</th> <th>DESCRIPTION</th> </tr> <tr> <td>1</td> <td>17MAY95</td> <td>WF</td> <td></td> </tr> </table>								REV. NO.	DATE	APPROVED	DESCRIPTION	1	17MAY95	WF									
REV. NO.	DATE	APPROVED	DESCRIPTION																				
1	17MAY95	WF																					
<table border="1" style="width: 100%; border-collapse: collapse;"> <tr> <th>REV. NO.</th> <th>DATE</th> <th>APPROVED</th> <th>DESCRIPTION</th> </tr> <tr> <td>1</td> <td>17MAY95</td> <td>WF</td> <td></td> </tr> </table>								REV. NO.	DATE	APPROVED	DESCRIPTION	1	17MAY95	WF									
REV. NO.	DATE	APPROVED	DESCRIPTION																				
1	17MAY95	WF																					
<table border="1" style="width: 100%; border-collapse: collapse;"> <tr> <th>REV. NO.</th> <th>DATE</th> <th>APPROVED</th> <th>DESCRIPTION</th> </tr> <tr> <td>1</td> <td>17MAY95</td> <td>WF</td> <td></td> </tr> </table>								REV. NO.	DATE	APPROVED	DESCRIPTION	1	17MAY95	WF									
REV. NO.	DATE	APPROVED	DESCRIPTION																				
1	17MAY95	WF																					
<table border="1" style="width: 100%; border-collapse: collapse;"> <tr> <th>REV. NO.</th> <th>DATE</th> <th>APPROVED</th> <th>DESCRIPTION</th> </tr> <tr> <td>1</td> <td>17MAY95</td> <td>WF</td> <td></td> </tr> </table>								REV. NO.	DATE	APPROVED	DESCRIPTION	1	17MAY95	WF									
REV. NO.	DATE	APPROVED	DESCRIPTION																				
1	17MAY95	WF																					
<table border="1" style="width: 100%; border-collapse: collapse;"> <tr> <th>REV. NO.</th> <th>DATE</th> <th>APPROVED</th> <th>DESCRIPTION</th> </tr> <tr> <td>1</td> <td>17MAY95</td> <td>WF</td> <td></td> </tr> </table>								REV. NO.	DATE	APPROVED	DESCRIPTION	1	17MAY95	WF									
REV. NO.	DATE	APPROVED	DESCRIPTION																				
1	17MAY95	WF																					
<table border="1" style="width: 100%; border-collapse: collapse;"> <tr> <th>REV. NO.</th> <th>DATE</th> <th>APPROVED</th> <th>DESCRIPTION</th> </tr> <tr> <td>1</td> <td>17MAY95</td> <td>WF</td> <td></td> </tr> </table>								REV. NO.	DATE	APPROVED	DESCRIPTION	1	17MAY95	WF									
REV. NO.	DATE	APPROVED	DESCRIPTION																				
1	17MAY95	WF																					
<table border="1" style="width: 100%; border-collapse: collapse;"> <tr> <th>REV. NO.</th> <th>DATE</th> <th>APPROVED</th> <th>DESCRIPTION</th> </tr> <tr> <td>1</td> <td>17MAY95</td> <td>WF</td> <td></td> </tr> </table>								REV. NO.	DATE	APPROVED	DESCRIPTION	1	17MAY95	WF									
REV. NO.	DATE	APPROVED	DESCRIPTION																				
1	17MAY95	WF																					
<table border="1" style="width: 100%; border-collapse: collapse;"> <tr> <th>REV. NO.</th> <th>DATE</th> <th>APPROVED</th> <th>DESCRIPTION</th> </tr> <tr> <td>1</td> <td>17MAY95</td> <td>WF</td> <td></td> </tr> </table>								REV. NO.	DATE	APPROVED	DESCRIPTION	1	17MAY95	WF									
REV. NO.	DATE	APPROVED	DESCRIPTION																				
1	17MAY95	WF																					
<table border="1" style="width: 100%; border-collapse: collapse;"> <tr> <th>REV. NO.</th> <th>DATE</th> <th>APPROVED</th> <th>DESCRIPTION</th> </tr> <tr> <td>1</td> <td>17MAY95</td> <td>WF</td> <td></td> </tr> </table>								REV. NO.	DATE	APPROVED	DESCRIPTION	1	17MAY95	WF									
REV. NO.	DATE	APPROVED	DESCRIPTION																				
1	17MAY95	WF																					
<table border="1" style="width: 100%; border-collapse: collapse;"> <tr> <th>REV. NO.</th> <th>DATE</th> <th>APPROVED</th> <th>DESCRIPTION</th> </tr> <tr> <td>1</td> <td>17MAY95</td> <td>WF</td> <td></td> </tr> </table>								REV. NO.	DATE	APPROVED	DESCRIPTION	1	17MAY95	WF									
REV. NO.	DATE	APPROVED	DESCRIPTION																				
1	17MAY95	WF																					
<table border="1" style="width: 100%; border-collapse: collapse;"> <tr> <th>REV. NO.</th> <th>DATE</th> <th>APPROVED</th> <th>DESCRIPTION</th> </tr> <tr> <td>1</td> <td>17MAY95</td> <td>WF</td> <td></td> </tr> </table>								REV. NO.	DATE	APPROVED	DESCRIPTION	1	17MAY95	WF									
REV. NO.	DATE	APPROVED	DESCRIPTION																				
1	17MAY95	WF																					
<table border="1" style="width: 100%; border-collapse: collapse;"> <tr> <th>REV. NO.</th> <th>DATE</th> <th>APPROVED</th> <th>DESCRIPTION</th> </tr> <tr> <td>1</td> <td>17MAY95</td> <td>WF</td> <td></td> </tr> </table>								REV. NO.	DATE	APPROVED	DESCRIPTION	1	17MAY95	WF									
REV. NO.	DATE	APPROVED	DESCRIPTION																				
1	17MAY95	WF																					
<table border="1" style="width: 100%; border-collapse: collapse;"> <tr> <th>REV. NO.</th> <th>DATE</th> <th>APPROVED</th> <th>DESCRIPTION</th> </tr> <tr> <td>1</td> <td>17MAY95</td> <td>WF</td> <td></td> </tr> </table>								REV. NO.	DATE	APPROVED	DESCRIPTION	1	17MAY95	WF									
REV. NO.	DATE	APPROVED	DESCRIPTION																				
1	17MAY95	WF																					
<table border="1" style="width: 100%; border-collapse: collapse;"> <tr> <th>REV. NO.</th> <th>DATE</th> <th>APPROVED</th> <th>DESCRIPTION</th> </tr> <tr> <td>1</td> <td>17MAY95</td> <td>WF</td> <td></td> </tr> </table>								REV. NO.	DATE	APPROVED	DESCRIPTION	1	17MAY95	WF									
REV. NO.	DATE	APPROVED	DESCRIPTION																				
1	17MAY95	WF																					
<table border="1" style="width: 100%; border-collapse: collapse;"> <tr> <th>REV. NO.</th> <th>DATE</th> <th>APPROVED</th> <th>DESCRIPTION</th> </tr> <tr> <td>1</td> <td>17MAY95</td> <td>WF</td> <td></td> </tr> </table>								REV. NO.	DATE	APPROVED	DESCRIPTION	1	17MAY95	WF									
REV. NO.	DATE	APPROVED	DESCRIPTION																				
1	17MAY95	WF																					
<table border="1" style="width: 100%; border-collapse: collapse;"> <tr> <th>REV. NO.</th> <th>DATE</th> <th>APPROVED</th> <th>DESCRIPTION</th> </tr> <tr> <td>1</td> <td>17MAY95</td> <td>WF</td> <td></td> </tr> </table>								REV. NO.	DATE	APPROVED	DESCRIPTION	1	17MAY95	WF									
REV. NO.	DATE	APPROVED	DESCRIPTION																				
1	17MAY95	WF																					
<table border="1" style="width: 100%; border-collapse: collapse;"> <tr> <th>REV. NO.</th> <th>DATE</th> <th>APPROVED</th> <th>DESCRIPTION</th> </tr> <tr> <td>1</td> <td>17MAY95</td> <td>WF</td> <td></td> </tr> </table>								REV. NO.	DATE	APPROVED	DESCRIPTION	1	17MAY95	WF									
REV. NO.	DATE	APPROVED	DESCRIPTION																				
1	17MAY95	WF																					
<table border="1" style="width: 100%; border-collapse: collapse;"> <tr> <th>REV. NO.</th> <th>DATE</th> <th>APPROVED</th> <th>DESCRIPTION</th> </tr> <tr> <td>1</td> <td>17MAY95</td> <td>WF</td> <td></td> </tr> </table>								REV. NO.	DATE	APPROVED	DESCRIPTION	1	17MAY95	WF									
REV. NO.	DATE	APPROVED	DESCRIPTION																				
1	17MAY95	WF																					
<table border="1" style="width: 100%; border-collapse: collapse;"> <tr> <th>REV. NO.</th> <th>DATE</th> <th>APPROVED</th> <th>DESCRIPTION</th> </tr> <tr> <td>1</td> <td>17MAY95</td> <td>WF</td> <td></td> </tr> </table>								REV. NO.	DATE	APPROVED	DESCRIPTION	1	17MAY95	WF									
REV. NO.	DATE	APPROVED	DESCRIPTION																				
1	17MAY95	WF																					
<table border="1" style="width: 100%; border-collapse: collapse;"> <tr> <th>REV. NO.</th> <th>DATE</th> <th>APPROVED</th> <th>DESCRIPTION</th> </tr> <tr> <td>1</td> <td>17MAY95</td> <td>WF</td> <td></td> </tr> </table>								REV. NO.	DATE	APPROVED	DESCRIPTION	1	17MAY95	WF									
REV. NO.	DATE	APPROVED	DESCRIPTION																				
1	17MAY95	WF																					
<table border="1" style="width: 100%; border-collapse: collapse;"> <tr> <th>REV. NO.</th> <th>DATE</th> <th>APPROVED</th> <th>DESCRIPTION</th> </tr> <tr> <td>1</td> <td>17MAY95</td> <td>WF</td> <td></td> </tr> </table>								REV. NO.	DATE	APPROVED	DESCRIPTION	1	17MAY95	WF									
REV. NO.	DATE	APPROVED	DESCRIPTION																				
1	17MAY95	WF																					
<table border="1" style="width: 100%; border-collapse: collapse;"> <tr> <th>REV. NO.</th> <th>DATE</th> <th>APPROVED</th> <th>DESCRIPTION</th> </tr> <tr> <td>1</td> <td>17MAY95</td> <td>WF</td> <td></td> </tr> </table>								REV. NO.	DATE	APPROVED	DESCRIPTION	1	17MAY95	WF									
REV. NO.	DATE	APPROVED	DESCRIPTION																				
1	17MAY95	WF																					
<table border="1" style="width: 100%; border-collapse: collapse;"> <tr> <th>REV. NO.</th> <th>DATE</th> <th>APPROVED</th> <th>DESCRIPTION</th> </tr> <tr> <td>1</td> <td>17MAY95</td> <td>WF</td> <td></td> </tr> </table>								REV. NO.	DATE	APPROVED	DESCRIPTION	1	17MAY95	WF									
REV. NO.	DATE	APPROVED	DESCRIPTION																				
1	17MAY95	WF																					
<table border="1" style="width: 100%; border-collapse: collapse;"> <tr> <th>REV. NO.</th> <th>DATE</th> <th>APPROVED</th> <th>DESCRIPTION</th> </tr> <tr> <td>1</td> <td>17MAY95</td> <td>WF</td> <td></td> </tr> </table>								REV. NO.	DATE	APPROVED	DESCRIPTION	1	17MAY95	WF									
REV. NO.	DATE	APPROVED	DESCRIPTION																				
1	17MAY95	WF																					
<table border="1" style="width: 100%; border-collapse: collapse;"> <tr> <th>REV. NO.</th> <th>DATE</th> <th>APPROVED</th> <th>DESCRIPTION</th> </tr> <tr> <td>1</td> <td>17MAY95</td> <td>WF</td> <td></td> </tr> </table>								REV. NO.	DATE	APPROVED	DESCRIPTION	1	17MAY95	WF									
REV. NO.	DATE	APPROVED	DESCRIPTION																				
1	17MAY95	WF																					
<table border="1" style="width: 100%; border-collapse: collapse;"> <tr> <th>REV. NO.</th> <th>DATE</th> <th>APPROVED</th> <th>DESCRIPTION</th> </tr> <tr> <td>1</td> <td>17MAY95</td> <td>WF</td> <td></td> </tr> </table>								REV. NO.	DATE	APPROVED	DESCRIPTION	1	17MAY95	WF									
REV. NO.	DATE	APPROVED	DESCRIPTION																				
1	17MAY95	WF																					
<table border="1" style="width: 100%; border-collapse: collapse;"> <tr> <th>REV. NO.</th> <th>DATE</th> <th>APPROVED</th> <th>DESCRIPTION</th> </tr> <tr> <td>1</td> <td>17MAY95</td> <td>WF</td> <td></td> </tr> </table>								REV. NO.	DATE	APPROVED	DESCRIPTION	1	17MAY95	WF									
REV. NO.	DATE	APPROVED	DESCRIPTION																				
1	17MAY95	WF																					
<table border="1" style="width: 100%; border-collapse: collapse;"> <tr> <th>REV. NO.</th> <th>DATE</th> <th>APPROVED</th> <th>DESCRIPTION</th> </tr> <tr> <td>1</td> <td>17MAY95</td> <td>WF</td> <td></td> </tr> </table>								REV. NO.	DATE	APPROVED	DESCRIPTION	1	17MAY95	WF									
REV. NO.	DATE	APPROVED	DESCRIPTION																				
1	17MAY95	WF																					
<table border="1" style="width: 100%; border-collapse: collapse;"> <tr> <th>REV. NO.</th> <th>DATE</th> <th>APPROVED</th> <th>DESCRIPTION</th> </tr> <tr> <td>1</td> <td>17MAY95</td> <td>WF</td> <td></td> </tr> </table>								REV. NO.	DATE	APPROVED	DESCRIPTION	1	17MAY95	WF									
REV. NO.	DATE	APPROVED	DESCRIPTION																				
1	17MAY95	WF																					
<table border="1" style="width: 100%; border-collapse: collapse;"> <tr> <th>REV. NO.</th> <th>DATE</th> <th>APPROVED</th> <th>DESCRIPTION</th> </tr> <tr> <td>1</td> <td>17MAY95</td> <td>WF</td> <td></td> </tr> </table>								REV. NO.	DATE	APPROVED	DESCRIPTION	1	17MAY95	WF									
REV. NO.	DATE	APPROVED	DESCRIPTION																				
1	17MAY95	WF																					
<table border="1" style="width: 100%; border-collapse: collapse;"> <tr> <th>REV. NO.</th> <th>DATE</th> <th>APPROVED</th> <th>DESCRIPTION</th> </tr> <tr> <td>1</td> <td>17MAY95</td> <td>WF</td> <td></td> </tr> </table>								REV. NO.	DATE	APPROVED	DESCRIPTION	1	17MAY95	WF									
REV. NO.	DATE	APPROVED	DESCRIPTION																				
1	17MAY95	WF																					
<table border="1" style="width: 100%; border-collapse: collapse;"> <tr> <th>REV. NO.</th> <th>DATE</th> <th>APPROVED</th> <th>DESCRIPTION</th> </tr> <tr> <td>1</td> <td>17MAY95</td> <td>WF</td> <td></td> </tr> </table>								REV. NO.	DATE	APPROVED	DESCRIPTION	1	17MAY95	WF									
REV. NO.	DATE	APPROVED	DESCRIPTION																				
1	17MAY95	WF																					
<table border="1" style="width: 100%; border-collapse: collapse;"> <tr> <th>REV. NO.</th> <th>DATE</th> <th>APPROVED</th> <th>DESCRIPTION</th> </tr> <tr> <td>1</td> <td>17MAY95</td> <td>WF</td> <td></td> </tr> </table>								REV. NO.	DATE	APPROVED	DESCRIPTION	1	17MAY95	WF									
REV. NO.	DATE	APPROVED	DESCRIPTION																				
1	17MAY95	WF																					
<table border="1" style="width: 100%; border-collapse: collapse;"> <tr> <th>REV. NO.</th> <th>DATE</th> <th>APPROVED</th> <th>DESCRIPTION</th> </tr> <tr> <td>1</td> <td>17MAY95</td> <td>WF</td> <td></td> </tr> </table>								REV. NO.	DATE	APPROVED	DESCRIPTION	1	17MAY95	WF									
REV. NO.	DATE	APPROVED	DESCRIPTION																				
1	17MAY95	WF																					
<table border="1" style="width: 100%; border-collapse: collapse;"> <tr> <th>REV. NO.</th> <th>DATE</th> <th>APPROVED</th> <th>DESCRIPTION</th> </tr> <tr> <td>1</td> <td>17MAY95</td> <td>WF</td> <td></td> </tr> </table>								REV. NO.	DATE	APPROVED	DESCRIPTION	1	17MAY95	WF									
REV. NO.	DATE	APPROVED	DESCRIPTION																				
1	17MAY95	WF																					
<table border="1" style="width: 100%; border-collapse: collapse;"> <tr> <th>REV. NO.</th> <th>DATE</th> <th>APPROVED</th> <th>DESCRIPTION</th> </tr> <tr> <td>1</td> <td>17MAY95</td> <td>WF</td> <td></td> </tr> </table>								REV. NO.	DATE	APPROVED	DESCRIPTION	1	17MAY95	WF									
REV. NO.	DATE	APPROVED	DESCRIPTION																				
1	17MAY95	WF																					
<table border="1" style="width: 100%; border-collapse: collapse;"> <tr> <th>REV. NO.</th> <th>DATE</th> <th>APPROVED</th> <th>DESCRIPTION</th> </tr> <tr> <td>1</td> <td>17MAY95</td> <td>WF</td> <td></td> </tr> </table>								REV. NO.	DATE	APPROVED	DESCRIPTION	1	17MAY95	WF									
REV. NO.	DATE	APPROVED	DESCRIPTION																				
1	17MAY95	WF																					
<table border="1" style="width: 100%; border-collapse: collapse;"> <tr> <th>REV. NO.</th> <th>DATE</th> <th>APPROVED</th> <th>DESCRIPTION</th> </tr> <tr> <td>1</td> <td>17MAY95</td> <td>WF</td> <td></td> </tr> </table>								REV. NO.	DATE	APPROVED	DESCRIPTION	1	17MAY95	WF									
REV. NO.	DATE	APPROVED	DESCRIPTION																				
1	17MAY95	WF																					
<table border="1" style="width: 100%; border-collapse: collapse;"> <tr> <th>REV. NO.</th> <th>DATE</th> <th>APPROVED</th> <th>DESCRIPTION</th> </tr> <tr> <td>1</td> <td>17MAY95</td> <td>WF</td> <td></td> </tr> </table>								REV. NO.	DATE	APPROVED	DESCRIPTION	1	17MAY95	WF									
REV. NO.	DATE	APPROVED	DESCRIPTION																				
1	17MAY95	WF																					
<table border="1" style="width: 100%; border-collapse: collapse;"> <tr> <th>REV. NO.</th> <th>DATE</th> <th>APPROVED</th> <th>DESCRIPTION</th> </tr> <tr> <td>1</td> <td>17MAY95</td> <td>WF</td> <td></td> </tr> </table>								REV. NO.	DATE	APPROVED	DESCRIPTION	1	17MAY95	WF									
REV. NO.	DATE	APPROVED	DESCRIPTION																				
1	17MAY95	WF																					
<table border="1" style="width: 100%; border-collapse: collapse;"> <tr> <th>REV. NO.</th> <th>DATE</th> <th>APPROVED</th> <th>DESCRIPTION</th> </tr> <tr> <td>1</td> <td>17MAY95</td> <td>WF</td> <td></td> </tr> </table>								REV. NO.	DATE	APPROVED	DESCRIPTION	1	17MAY95	WF									
REV. NO.	DATE	APPROVED	DESCRIPTION																				
1	17MAY95	WF																					
<table border="1" style="width: 100%; border-collapse: collapse;"> <tr> <th>REV. NO.</th> <th>DATE</th> <th>APPROVED</th> <th>DESCRIPTION</th> </tr> <tr> <td>1</td> <td>17MAY95</td> <td>WF</td> <td></td> </tr> </table>								REV. NO.	DATE	APPROVED	DESCRIPTION	1	17MAY95	WF									
REV. NO.	DATE	APPROVED	DESCRIPTION																				
1	17MAY95	WF																					
<table border="1" style="width: 100%; border-collapse: collapse;"> <tr> <th>REV. NO.</th> <th>DATE</th> <th>APPROVED</th> <th>DESCRIPTION</th> </tr> <tr> <td>1</td> <td>17MAY95</td> <td>WF</td> <td></td> </tr> </table>								REV. NO.	DATE	APPROVED	DESCRIPTION	1	17MAY95	WF									
REV. NO.	DATE	APPROVED	DESCRIPTION																				
1	17MAY95	WF																					
<table border="1" style="width: 100%; border-collapse: collapse;"> <tr> <th>REV. NO.</th> <th>DATE</th> <th>APPROVED</th> <th>DESCRIPTION</th> </tr> <tr> <td>1</td> <td>17MAY95</td> <td>WF</td> <td></td> </tr> </table>								REV. NO.	DATE	APPROVED	DESCRIPTION	1	17MAY95	WF									
REV. NO.	DATE	APPROVED	DESCRIPTION																				
1	17MAY95	WF																					
<table border="1" style="width: 100%; border-collapse: collapse;"> <tr> <th>REV. NO.</th> <th>DATE</th> <th>APPROVED</th> <th>DESCRIPTION</th> </tr> <tr> <td>1</td> <td>17MAY95</td> <td>WF</td> <td></td> </tr> </table>								REV. NO.	DATE	APPROVED	DESCRIPTION	1	17MAY95	WF									
REV. NO.	DATE	APPROVED	DESCRIPTION																				
1	17MAY95	WF																					
<table border="1" style="width: 100%; border-collapse: collapse;"> <tr> <th>REV. NO.</th> <th>DATE</th> <th>APPROVED</th> <th>DESCRIPTION</th> </tr> <tr> <td>1</td> <td>17MAY95</td> <td>WF</td> <td></td> </tr> </table>								REV. NO.	DATE	APPROVED	DESCRIPTION	1	17MAY95	WF									
REV. NO.	DATE	APPROVED	DESCRIPTION																				
1	17MAY95	WF																					
<table border="1" style="width: 100%; border-collapse: collapse;"> <tr> <th>REV. NO.</th> <th>DATE</th> <th>APPROVED</th> <th>DESCRIPTION</th> </tr> <tr> <td>1</td> <td>17MAY95</td> <td>WF</td> <td></td> </tr> </table>								REV. NO.	DATE	APPROVED	DESCRIPTION	1	17MAY95	WF									
REV. NO.	DATE	APPROVED	DESCRIPTION																				
1	17MAY95	WF																					
<table border="1" style="width: 100%; border-collapse: collapse;"> <tr> <th>REV. NO.</th> <th>DATE</th> <th>APPROVED</th> <th>DESCRIPTION</th> </tr> <tr> <td>1</td> <td>17MAY95</td> <td>WF</td> <td></td> </tr> </table>								REV. NO.	DATE	APPROVED	DESCRIPTION	1	17MAY95	WF									
REV. NO.	DATE	APPROVED	DESCRIPTION																				
1	17MAY95	WF																					
<table border="1" style="width: 100%; border-collapse: collapse;"> <tr> <th>REV. NO.</th> <th>DATE</th> <th>APPROVED</th> <th>DESCRIPTION</th> </tr> <tr> <td>1</td> <td>17MAY95</td> <td>WF</td> <td></td> </tr> </table>								REV. NO.	DATE	APPROVED	DESCRIPTION	1	17MAY95	WF									
REV. NO.	DATE	APPROVED	DESCRIPTION																				
1	17MAY95	WF																					
<table border="1" style="width: 100%; border-collapse: collapse;"> <tr> <th>REV. NO.</th> <th>DATE</th> <th>APPROVED</th> <th>DESCRIPTION</th> </tr> <tr> <td>1</td> <td>17MAY95</td> <td>WF</td> <td></td> </tr> </table>								REV. NO.	DATE	APPROVED	DESCRIPTION	1	17MAY95	WF									
REV. NO.	DATE	APPROVED	DESCRIPTION																				
1	17MAY95	WF																					
<table border="1" style="width: 100%; border-collapse: collapse;"> <tr> <th>REV. NO.</th> <th>DATE</th> <th>APPROVED</th> <th>DESCRIPTION</th> </tr> <tr> <td>1</td> <td>17MAY95</td> <td>WF</td> <td></td> </tr> </table>								REV. NO.	DATE	APPROVED	DESCRIPTION	1	17MAY95	WF									
REV. NO.	DATE	APPROVED	DESCRIPTION																				
1	17MAY95	WF																					
<table border="1" style="width: 100%; border-collapse: collapse;"> <tr> <th>REV. NO.</th> <th>DATE</th> <th>APPROVED</th> <th>DESCRIPTION</th> </tr> <tr> <td>1</td> <td>17MAY95</td> <td>WF</td> <td></td> </tr> </table>								REV. NO.	DATE	APPROVED	DESCRIPTION	1	17MAY95	WF									
REV. NO.	DATE	APPROVED	DESCRIPTION																				
1	17MAY95	WF																					
<table border="1" style="width: 100%; border-collapse: collapse;"> <tr> <th>REV. NO.</th> <th>DATE</th> <th>APPROVED</th> <th>DESCRIPTION</th> </tr> <tr> <td>1</td> <td>17MAY95</td> <td>WF</td> <td></td> </tr> </table>								REV. NO.	DATE	APPROVED	DESCRIPTION	1	17MAY95	WF									
REV. NO.	DATE	APPROVED	DESCRIPTION																				
1	17MAY95	WF																					
<table border="1" style="width: 100%; border-collapse: collapse;"> <tr> <th>REV. NO.</th> <th>DATE</th> <th>APPROVED</th> <th>DESCRIPTION</th> </tr> <tr> <td>1</td> <td>17MAY95</td> <td>WF</td> <td></td> </tr> </table>								REV. NO.	DATE	APPROVED	DESCRIPTION	1	17MAY95	WF									
REV. NO.	DATE	APPROVED	DESCRIPTION																				
1	17MAY95	WF																					
<table border="1" style="width: 100%; border-collapse: collapse;"> <tr> <th>REV. NO.</th> <th>DATE</th> <th>APPROVED</th> <th>DESCRIPTION</th> </tr> <tr> <td>1</td> <td>17MAY95</td> <td>WF</td> <td></td> </tr> </table>								REV. NO.	DATE	APPROVED	DESCRIPTION	1	17MAY95	WF									
REV. NO.	DATE	APPROVED	DESCRIPTION																				
1	17MAY95	WF																					
<table border="1" style="width: 100%; border-collapse: collapse;"> <tr> <th>REV. NO.</th> <th>DATE</th> <th>APPROVED</th> <th>DESCRIPTION</th> </tr> <tr> <td>1</td> <td>17MAY95</td> <td>WF</td> <td></td> </tr> </table>								REV. NO.	DATE	APPROVED	DESCRIPTION	1	17MAY95	WF									
REV. NO.	DATE	APPROVED	DESCRIPTION																				
1	17MAY95	WF																					
<table border="1" style="width: 100%; border-collapse: collapse;"> <tr> <th>REV. NO.</th> <th>DATE</th> <th>APPROVED</th> <th>DESCRIPTION</th> </tr> <tr> <td>1</td> <td>17MAY95</td> <td>WF</td> <td></td> </tr> </table>								REV. NO.	DATE	APPROVED	DESCRIPTION	1	17MAY95	WF									
REV. NO.	DATE	APPROVED	DESCRIPTION																				
1	17MAY95	WF																					
<table border="1" style="width: 100%; border-collapse: collapse;"> <tr> <th>REV. NO.</th> <th>DATE</th> <th>APPROVED</th> <th>DESCRIPTION</th> </tr> <tr> <td>1</td> <td>17MAY95</td> <td>WF</td> <td></td> </tr> </table>								REV. NO.	DATE	APPROVED	DESCRIPTION	1	17MAY95	WF									
REV. NO.	DATE	APPROVED	DESCRIPTION																				
1	17MAY95	WF																					
<table border="1" style="width: 100%; border-collapse: collapse;"> <tr> <th>REV. NO.</th> <th>DATE</th> <th>APPROVED</th> <th>DESCRIPTION</th> </tr> <tr> <td>1</td> <td>17MAY95</td> <td>WF</td> <td></td> </tr> </table>								REV. NO.	DATE	APPROVED	DESCRIPTION	1	17MAY95	WF									
REV. NO.	DATE	APPROVED	DESCRIPTION																				
1	17MAY95	WF																					
<table border="1" style="width: 100%; border-collapse: collapse;"> <tr> <th>REV. NO.</th> <th>DATE</th> <th>APPROVED</th> <th>DESCRIPTION</th> </tr> <tr> <td>1</td> <td>17MAY95</td> <td>WF</td> <td></td> </tr> </table>								REV. NO.	DATE	APPROVED	DESCRIPTION	1	17MAY95	WF									
REV. NO.	DATE	APPROVED	DESCRIPTION																				
1	17MAY95	WF																					
<table border="1" style="width: 100%; border-collapse: collapse;"> <tr> <th>REV. NO.</th> <th>DATE</th> <th>APPROVED</th> <th>DESCRIPTION</th> </tr> <tr> <td>1</td> <td>17MAY95</td> <td>WF</td> <td></td> </tr> </table>								REV. NO.	DATE	APPROVED	DESCRIPTION	1	17MAY95	WF									
REV. NO.	DATE	APPROVED	DESCRIPTION																				
1	17MAY95	WF																					
<table border="1" style="width: 100%; border-collapse: collapse;"> <tr> <th>REV. NO.</th> <th>DATE</th> <th>APPROVED</th> <th>DESCRIPTION</th> </tr> <tr> <td>1</td> <td>17MAY95</td> <td>WF</td> <td></td> </tr> </table>								REV. NO.	DATE	APPROVED	DESCRIPTION	1	17MAY95	WF									
REV. NO.	DATE	APPROVED	DESCRIPTION																				
1	17MAY95	WF																					
<table border="1" style="width: 100%; border-collapse: collapse;"> <tr> <th>REV. NO.</th> <th>DATE</th> <th>APPROVED</th> <th>DESCRIPTION</th> </tr> <tr> <td>1</td> <td>17MAY95</td> <td>WF</td> <td></td> </tr> </table>								REV. NO.	DATE	APPROVED	DESCRIPTION	1	17MAY95	WF									
REV. NO.	DATE	APPROVED	DESCRIPTION																				
1	17MAY95	WF																					
<table border="1" style="width: 100%; border-collapse: collapse;"> <tr> <th>REV. NO.</th> <th>DATE</th> <th>APPROVED</th> <th>DESCRIPTION</th> </tr> <tr> <td>1</td> <td>17MAY95</td> <td>WF</td> <td></td> </tr> </table>								REV. NO.	DATE	APPROVED	DESCRIPTION	1	17MAY95	WF									
REV. NO.	DATE	APPROVED	DESCRIPTION																				
1	17MAY95	WF																					
<table border="1" style="width: 100%; border-collapse: collapse;"> <tr> <th>REV. NO.</th> <th>DATE</th> <th>APPROVED</th> <th>DESCRIPTION</th> </tr> <tr> <td>1</td> <td>17MAY95</td> <td>WF</td> <td></td> </tr> </table>								REV. NO.	DATE	APPROVED	DESCRIPTION	1	17MAY95	WF									
REV. NO.	DATE	APPROVED	DESCRIPTION																				
1	17MAY95	WF																					
<table border="1" style="width: 100%; border-collapse: collapse;"> <tr> <th>REV. NO.</th> <th>DATE</th> <th>APPROVED</th> <th>DESCRIPTION</th> </tr> <tr> <td>1</td> <td>17MAY95</td> <td>WF</td> <td></td> </tr> </table>								REV. NO.	DATE	APPROVED	DESCRIPTION	1	17MAY95	WF									
REV. NO.	DATE	APPROVED	DESCRIPTION																				
1	17MAY95	WF																					
<table border="1" style="width: 100%; border-collapse: collapse;"> <tr> <th>REV. NO.</th> <th>DATE</th> <th>APPROVED</th> <th>DESCRIPTION</th> </tr> <tr> <td>1</td> <td>17MAY95</td> <td>WF</td> <td></td> </tr> </table>								REV. NO.	DATE	APPROVED	DESCRIPTION	1	17MAY95	WF									
REV. NO.	DATE	APPROVED	DESCRIPTION																				
1	17MAY95	WF																					
<table border="1" style="width: 100%; border-collapse: collapse;"> <tr> <th>REV. NO.</th> <th>DATE</th> <th>APPROVED</th> <th>DESCRIPTION</th> </tr> <tr> <td>1</td> <td>17MAY95</td> <td>WF</td> <td></td> </tr> </table>								REV. NO.	DATE	APPROVED	DESCRIPTION	1	17MAY95	WF									
REV. NO.	DATE	APPROVED	DESCRIPTION																				
1	17MAY95	WF																					
<table border="1" style="width: 100%; border-collapse: collapse;"> <tr> <th>REV. NO.</th> <th>DATE</th> <th>APPROVED</th> <th>DESCRIPTION</th> </tr> <tr> <td>1</td> <td>17MAY95</td> <td>WF</td> <td></td> </tr> </table>								REV. NO.	DATE	APPROVED	DESCRIPTION	1	17MAY95	WF									
REV. NO.	DATE	APPROVED	DESCRIPTION																				
1	17MAY95	WF																					
<table border="1" style="width: 100%; border-collapse: collapse;"> <tr> <th>REV. NO.</th> <th>DATE</th> <th>APPROVED</th> <th>DESCRIPTION</th> </tr> <tr> <td>1</td> <td>17MAY95</td> <td>WF</td> <td></td> </tr> </table>								REV. NO.	DATE	APPROVED	DESCRIPTION	1	17MAY95	WF									
REV. NO.	DATE	APPROVED	DESCRIPTION																				
1	17MAY95	WF																					
<table border="1" style="width: 100%; border-collapse: collapse;"> <tr> <th>REV. NO.</th> <th>DATE</th> <th>APPROVED</th> <th>DESCRIPTION</th> </tr> <tr> <td>1</td> <td>17MAY95</td> <td>WF</td> <td></td> </tr> </table>								REV. NO.	DATE	APPROVED	DESCRIPTION	1	17MAY95	WF									
REV. NO.	DATE	APPROVED	DESCRIPTION																				
1	17MAY95	WF																					

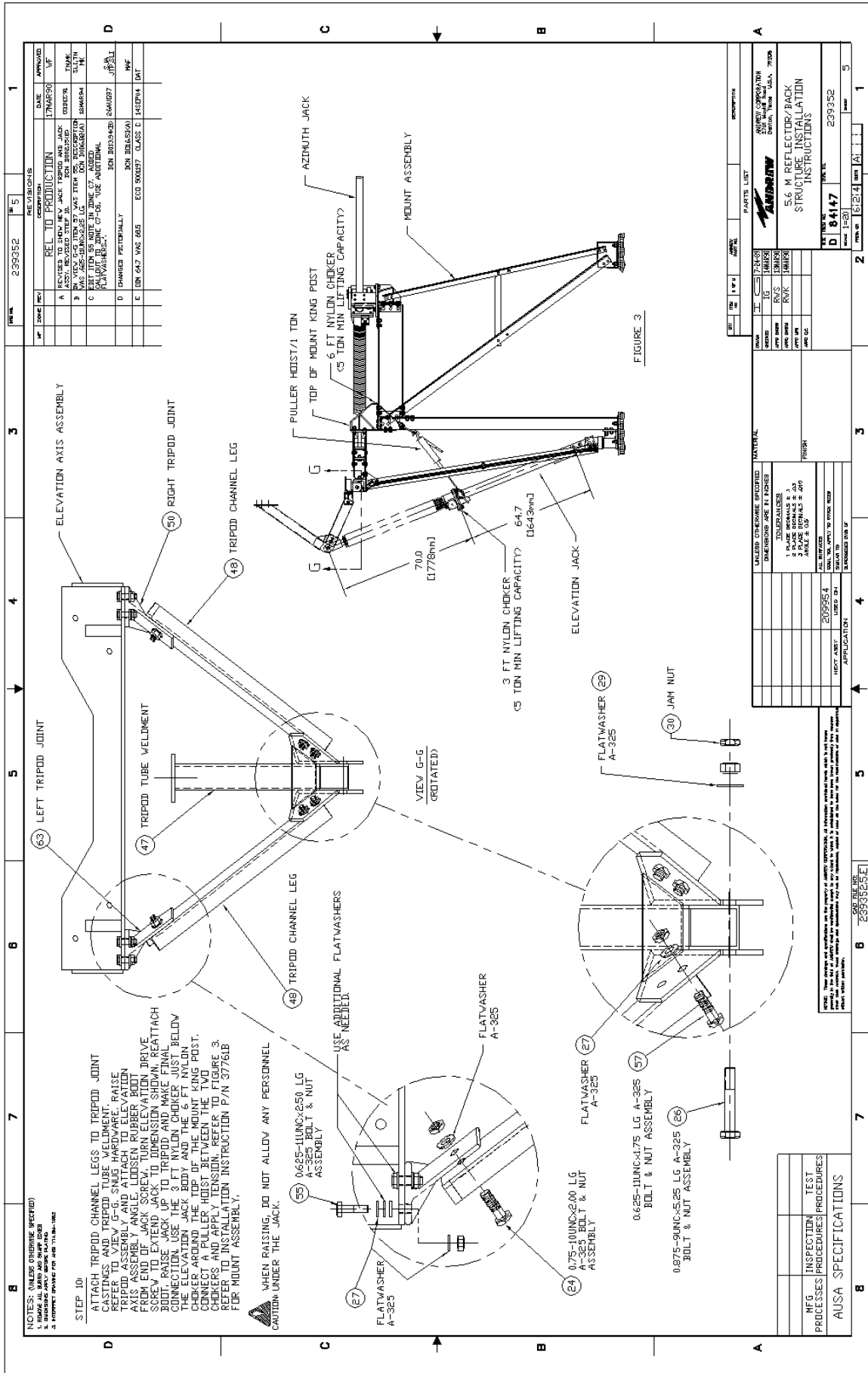

NOTES: (UNLESS OTHERWISE SPECIFIED)
 1. DIMENSIONS ARE IN INCHES
 2. DIMENSIONS ARE IN MILLIMETERS
 3. DIMENSIONS ARE IN MILLIMETERS

STEP 10:
 ATTACH TRIPOD CHANNEL LEGS TO TRIPOD JOINT CASTINGS AND TRIPOD TUBE WELDMENT. RAISE REFER TO VIEW G-G. SNUG HARDWARE. RAISE TRIPOD ASSEMBLY AND ATTACH ELEVATION AXIS ASSEMBLY TO JACK SCREW. TURN ELEVATION DRIVE SCREW TO EXTEND JACK TO DIMENSION SHOWN. REATTACH BOOT. RAISE JACK UP TO TRIPOD AND MAKE FINAL CONNECTION. USE THE 3 FT NYLON CHOKER JUST BELOW THE ELEVATION JACK BODY AND THE 6 FT NYLON CHOKER TO TIGHTEN THE JACK TO THE KING POST. CONNECT A PULLER HOIST BETWEEN THE TWO CHOKERS AND APPLY TENSION. REFER TO FIGURE 3. REFER TO INSTALLATION INSTRUCTION P/N 37761B FOR MOUNT ASSEMBLY.

WHEN RAISING, DO NOT ALLOW ANY PERSONNEL CAUTION UNDER THE JACK.

REV	DATE	BY	CHKD	DESCRIPTION
1	12/28/90	WJ		REVISED
2	08/08/91	WJ		REVISED
3	08/08/91	WJ		REVISED
4	08/08/91	WJ		REVISED
5	08/08/91	WJ		REVISED
6	08/08/91	WJ		REVISED
7	08/08/91	WJ		REVISED
8	08/08/91	WJ		REVISED
9	08/08/91	WJ		REVISED
10	08/08/91	WJ		REVISED
11	08/08/91	WJ		REVISED
12	08/08/91	WJ		REVISED
13	08/08/91	WJ		REVISED
14	08/08/91	WJ		REVISED
15	08/08/91	WJ		REVISED
16	08/08/91	WJ		REVISED
17	08/08/91	WJ		REVISED
18	08/08/91	WJ		REVISED
19	08/08/91	WJ		REVISED
20	08/08/91	WJ		REVISED
21	08/08/91	WJ		REVISED
22	08/08/91	WJ		REVISED
23	08/08/91	WJ		REVISED
24	08/08/91	WJ		REVISED
25	08/08/91	WJ		REVISED
26	08/08/91	WJ		REVISED
27	08/08/91	WJ		REVISED
28	08/08/91	WJ		REVISED
29	08/08/91	WJ		REVISED
30	08/08/91	WJ		REVISED
31	08/08/91	WJ		REVISED
32	08/08/91	WJ		REVISED
33	08/08/91	WJ		REVISED
34	08/08/91	WJ		REVISED
35	08/08/91	WJ		REVISED
36	08/08/91	WJ		REVISED
37	08/08/91	WJ		REVISED
38	08/08/91	WJ		REVISED
39	08/08/91	WJ		REVISED
40	08/08/91	WJ		REVISED
41	08/08/91	WJ		REVISED
42	08/08/91	WJ		REVISED
43	08/08/91	WJ		REVISED
44	08/08/91	WJ		REVISED
45	08/08/91	WJ		REVISED
46	08/08/91	WJ		REVISED
47	08/08/91	WJ		REVISED
48	08/08/91	WJ		REVISED
49	08/08/91	WJ		REVISED
50	08/08/91	WJ		REVISED
51	08/08/91	WJ		REVISED
52	08/08/91	WJ		REVISED
53	08/08/91	WJ		REVISED
54	08/08/91	WJ		REVISED
55	08/08/91	WJ		REVISED
56	08/08/91	WJ		REVISED
57	08/08/91	WJ		REVISED
58	08/08/91	WJ		REVISED
59	08/08/91	WJ		REVISED
60	08/08/91	WJ		REVISED
61	08/08/91	WJ		REVISED
62	08/08/91	WJ		REVISED
63	08/08/91	WJ		REVISED
64	08/08/91	WJ		REVISED
65	08/08/91	WJ		REVISED
66	08/08/91	WJ		REVISED
67	08/08/91	WJ		REVISED
68	08/08/91	WJ		REVISED
69	08/08/91	WJ		REVISED
70	08/08/91	WJ		REVISED
71	08/08/91	WJ		REVISED
72	08/08/91	WJ		REVISED
73	08/08/91	WJ		REVISED
74	08/08/91	WJ		REVISED
75	08/08/91	WJ		REVISED
76	08/08/91	WJ		REVISED
77	08/08/91	WJ		REVISED
78	08/08/91	WJ		REVISED
79	08/08/91	WJ		REVISED
80	08/08/91	WJ		REVISED
81	08/08/91	WJ		REVISED
82	08/08/91	WJ		REVISED
83	08/08/91	WJ		REVISED
84	08/08/91	WJ		REVISED
85	08/08/91	WJ		REVISED
86	08/08/91	WJ		REVISED
87	08/08/91	WJ		REVISED
88	08/08/91	WJ		REVISED
89	08/08/91	WJ		REVISED
90	08/08/91	WJ		REVISED
91	08/08/91	WJ		REVISED
92	08/08/91	WJ		REVISED
93	08/08/91	WJ		REVISED
94	08/08/91	WJ		REVISED
95	08/08/91	WJ		REVISED
96	08/08/91	WJ		REVISED
97	08/08/91	WJ		REVISED
98	08/08/91	WJ		REVISED
99	08/08/91	WJ		REVISED
100	08/08/91	WJ		REVISED

REV	DATE	BY	CHKD	DESCRIPTION
1	12/28/90	WJ		REVISED
2	08/08/91	WJ		REVISED
3	08/08/91	WJ		REVISED
4	08/08/91	WJ		REVISED
5	08/08/91	WJ		REVISED
6	08/08/91	WJ		REVISED
7	08/08/91	WJ		REVISED
8	08/08/91	WJ		REVISED
9	08/08/91	WJ		REVISED
10	08/08/91	WJ		REVISED
11	08/08/91	WJ		REVISED
12	08/08/91	WJ		REVISED
13	08/08/91	WJ		REVISED
14	08/08/91	WJ		REVISED
15	08/08/91	WJ		REVISED
16	08/08/91	WJ		REVISED
17	08/08/91	WJ		REVISED
18	08/08/91	WJ		REVISED
19	08/08/91	WJ		REVISED
20	08/08/91	WJ		REVISED
21	08/08/91	WJ		REVISED
22	08/08/91	WJ		REVISED
23	08/08/91	WJ		REVISED
24	08/08/91	WJ		REVISED
25	08/08/91	WJ		REVISED
26	08/08/91	WJ		REVISED
27	08/08/91	WJ		REVISED
28	08/08/91	WJ		REVISED
29	08/08/91	WJ		REVISED
30	08/08/91	WJ		REVISED
31	08/08/91	WJ		REVISED
32	08/08/91	WJ		REVISED
33	08/08/91	WJ		REVISED
34	08/08/91	WJ		REVISED
35	08/08/91	WJ		REVISED
36	08/08/91	WJ		REVISED
37	08/08/91	WJ		REVISED
38	08/08/91	WJ		REVISED
39	08/08/91	WJ		REVISED
40	08/08/91	WJ		REVISED
41	08/08/91	WJ		REVISED
42	08/08/91	WJ		REVISED
43	08/08/91	WJ		REVISED
44	08/08/91	WJ		REVISED
45	08/08/91	WJ		REVISED
46	08/08/91	WJ		REVISED
47	08/08/91	WJ		REVISED
48	08/08/91	WJ		REVISED
49	08/08/91	WJ		REVISED
50	08/08/91	WJ		REVISED
51	08/08/91	WJ		REVISED
52	08/08/91	WJ		REVISED
53	08/08/91	WJ		REVISED
54	08/08/91	WJ		REVISED
55	08/08/91	WJ		REVISED
56	08/08/91	WJ		REVISED
57	08/08/91	WJ		REVISED
58	08/08/91	WJ		REVISED
59	08/08/91	WJ		REVISED
60	08/08/91	WJ		REVISED
61	08/08/91	WJ		REVISED
62	08/08/91	WJ		REVISED
63	08/08/91	WJ		REVISED
64	08/08/91	WJ		REVISED
65	08/08/91	WJ		REVISED
66	08/08/91	WJ		REVISED
67	08/08/91	WJ		REVISED
68	08/08/91	WJ		REVISED
69	08/08/91	WJ		REVISED
70	08/08/91	WJ		REVISED
71	08/08/91	WJ		REVISED
72	08/08/91	WJ		REVISED
73	08/08/91	WJ		REVISED
74	08/08/91	WJ		REVISED
75	08/08/91	WJ		REVISED
76	08/08/91	WJ		REVISED
77	08/08/91	WJ		REVISED
78	08/08/91	WJ		REVISED
79	08/08/91	WJ		REVISED
80	08/08/91	WJ		REVISED
81	08/08/91	WJ		REVISED
82	08/08/91	WJ		REVISED
83	08/08/91	WJ		REVISED
84	08/08/91	WJ		REVISED
85	08/08/91	WJ		REVISED
86	08/08/91	WJ		REVISED
87	08/08/91	WJ		REVISED
88	08/08/91	WJ		REVISED
89	08/08/91	WJ		REVISED
90	08/08/91	WJ		REVISED
91	08/08/91	WJ		REVISED
92	08/08/91	WJ		REVISED
93	08/08/91	WJ		REVISED
94	08/08/91	WJ		REVISED
95	08/08/91	WJ		REVISED
96	08/08/91	WJ		REVISED
97	08/08/91	WJ		REVISED
98	08/08/91	WJ		REVISED
99	08/08/91	WJ		REVISED
100	08/08/91	WJ		REVISED

REV	DATE	BY	CHKD	DESCRIPTION
1	12/28/90	WJ		REVISED
2	08/08/91	WJ		REVISED
3	08/08/91	WJ		REVISED
4	08/08/91	WJ		REVISED
5	08/08/91	WJ		REVISED
6	08/08/91	WJ		REVISED
7	08/08/91	WJ		REVISED
8	08/08/91	WJ		REVISED
9	08/08/91	WJ		REVISED
10	08/08/91	WJ		REVISED
11	08/08/91	WJ		REVISED
12	08/08/91	WJ		REVISED
13	08/08/91	WJ		REVISED
14	08/08/91	WJ		REVISED
15	08/08/91	WJ		REVISED
16	08/08/91	WJ		REVISED
17	08/08/91	WJ		REVISED
18	08/08/91	WJ		REVISED
19	08/08/91	WJ		REVISED
20	08/08/91	WJ		REVISED
21	08/08/91	WJ		REVISED
22	08/08/91	WJ		REVISED
23	08/			

Operation

Overview

After you have completed the assembly of your antenna, you are now ready to become operational. In order to operate the earth station antenna, you will need to direct it to the desired satellite adjusting both the elevation and azimuth angles appropriately. The following procedures provide details on how to correctly position your antenna on the desired satellite.

Acquiring A Satellite

There are several procedures that may be used to properly acquire the satellite. Andrew recommends that a spectrum analyzer be used. The following procedures provide explanation as to how to use the spectrum analyzer.

While viewing the spectrum analyzer screen, a pure noise signal as shown in Figure 4-1 will probably be observed. Additionally, some transponder signals may be observed above the noise signal as shown in Figure 4-2.

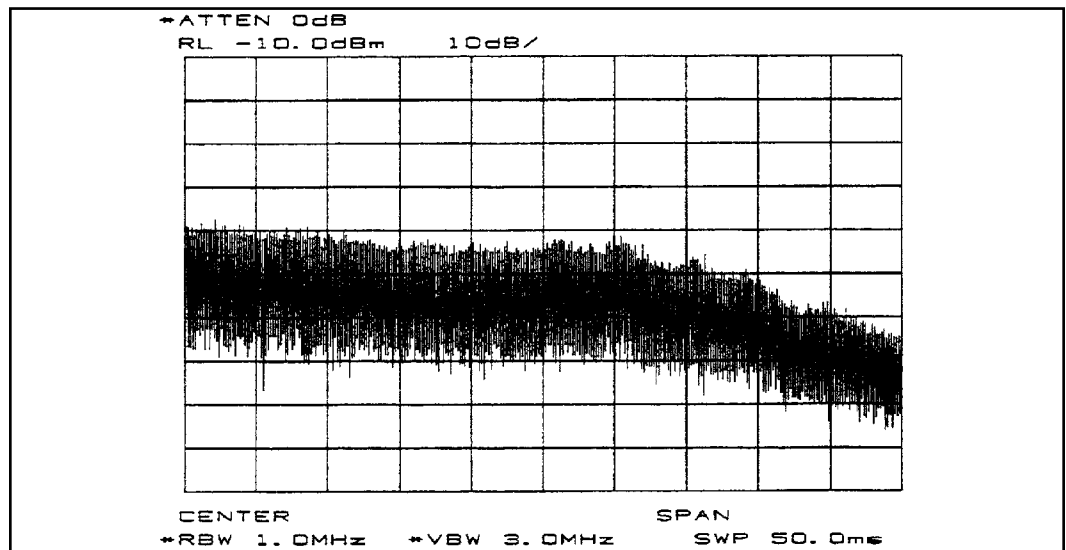

Figure 4-1: Pure Noise Signal on Spectrum Analyzer

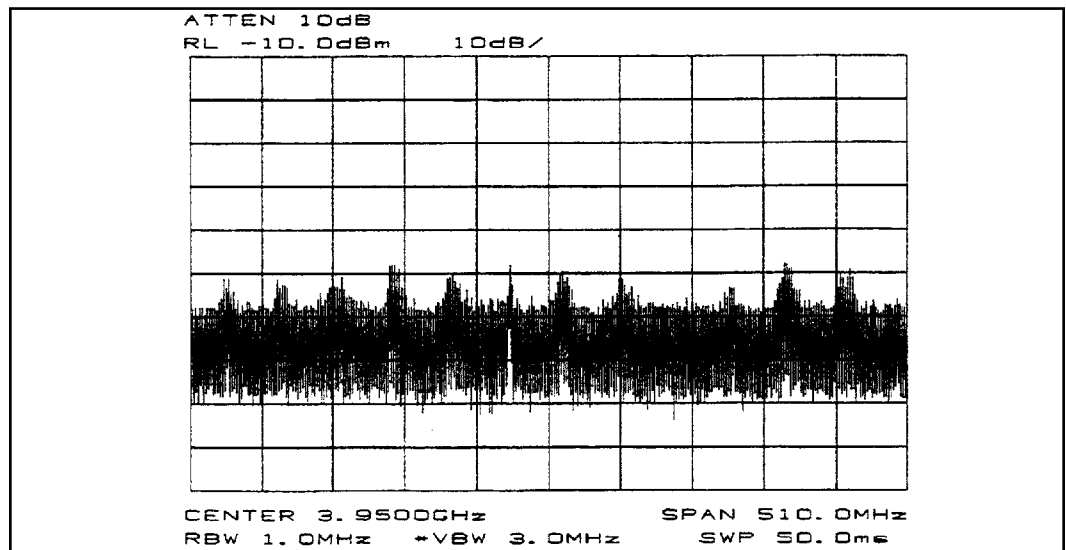

Figure 4-2: Minimum transponder Signal on Spectrum Analyzer

The following steps provide the procedure for acquiring a satellite.

Step 1

Manually move the antenna in the azimuth (scanning back-and-forth) to achieve the maximum (greatest amplitude) transponder signals.

- Scan in one direction until the amplitude continues to diminish and then scan in the opposite direction until the same condition occurs.
- Return to the position yielding the greatest amplitude.

The maximum azimuth excursion from the original setting should not exceed plus or minus 1.5 degrees or the antenna may begin to access a different satellite.

Step 2

With the antenna positioned in azimuth such that the transponder signals are maximized, follow the same procedure manually moving the antenna in elevation (scanning up-and-down) to further maximize the transponder signals.

Step 3

Repeat this procedure alternating between the azimuth and elevation excursions of the antenna to peak the transponder signal amplitude.

A transponder signal amplitude of 30 dB or greater from peak to average noise signal indicates the antenna is receiving the signal on the main beam. A transponder signal amplitude less than 30 dB or greater indicates the antenna is receiving the signal on a side lobe of the main beam.

Step 4

With the antenna peaked on a side lobe in azimuth and/or elevation, move the antenna in azimuth while observing the spectrum analyzer screen as shown in Figure 4-3.

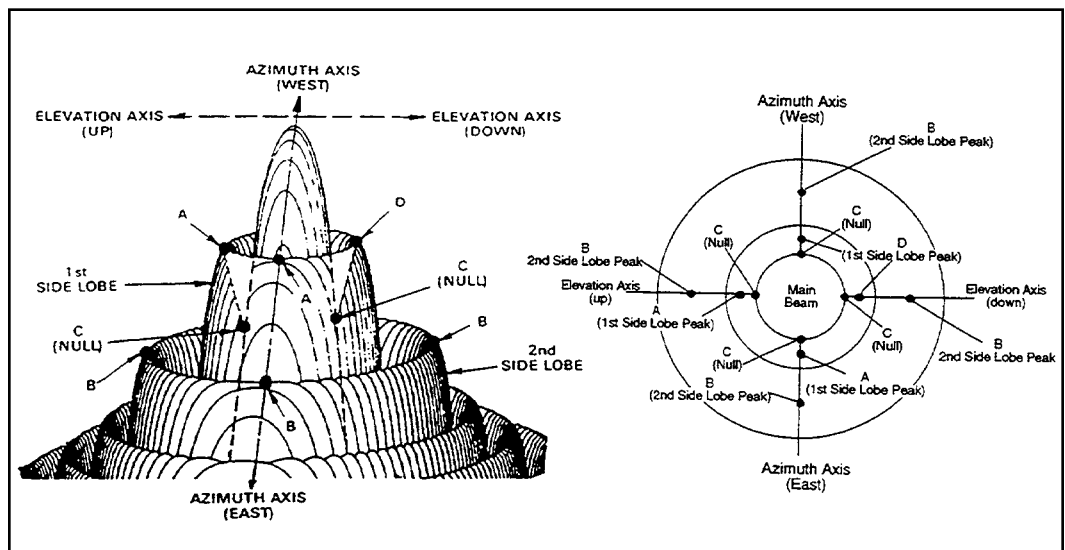

Figure 4-3: Antenna Radiation Pattern Topographical Diagram with Plan View

Step 5

If the signal amplitude diminishes and does not increase (position B) to the level noted when the antenna was peaked on the side lobe, the antenna is moving away from the main beam; reverse the direction of the antenna movement.

From the original side lobe position (position A), the signal amplitude should now diminish to a null point at position C (minimum amplitude showing only signal noise) and then symmetrically increase again to the same level at position D as noted at position A. At the null point (position C), the antenna is aligned with the alternate (elevation) axis. If the antenna was peaked on a side lobe in azimuth, it was appropriately aligned with the elevation axis; proceed with step 6. If the antenna was peaked on a side lobe in elevation, it was appropriately aligned with the azimuth axis; proceed with step 6 moving the antenna in azimuth rather than elevation.

Step 6

Move the antenna in elevation while observing the spectrum analyzer screen. If the signal amplitude increases, decreases and then increases again but to a lesser value, the antenna is moving in the wrong direction; reverse the direction of the antenna movement. From the original null point, the signal level should increase and decrease alternately, but with increasing amplitude until the transponder signal increases to a level of at least 30 dB at which time the main beam. Continue to manually peak the signal to a maximum level using the azimuth and elevation adjustments.

Step 7

If the antenna is aligned in azimuth and elevation (signal maximized) and 24 transponder signals (12 horizontal and 12 vertical) are noted, the polarization adjustment is set incorrectly and must be modified. If 12 transponder signals are noted, they may or may not be the properly polarized signals. Therefore 24 transponder signals must be visually noted in order to determine the proper polarization setting.

Step 8

Rotate the feed assembly clockwise until 24 transponder signals are noted and of approximately equal amplitude.

NOTE: It is more accurate and visually easier to minimize the alternate set of transponder signals rather than maximizing the transponder of interest.

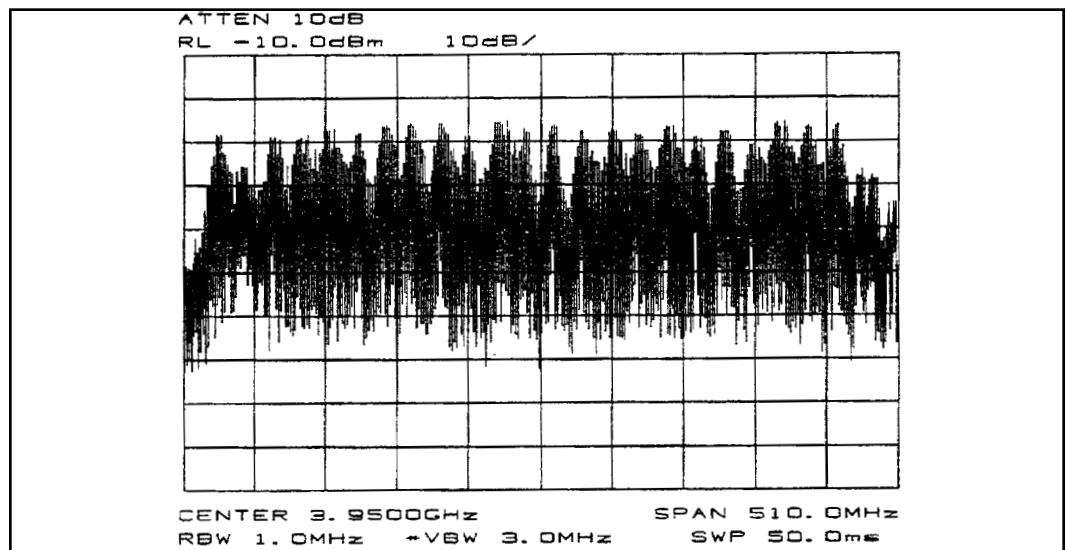

Figure 4-4: Polarization at 45 degrees from Optimum Setting

Step 9

With all 24 transponder signals of approximately equal amplitude appearing on the spectrum analyzer screen determine the specific antenna system and satellite parameters. Rotate the feed assembly as required until the appropriate (odd or even) transponder signals are maximized.

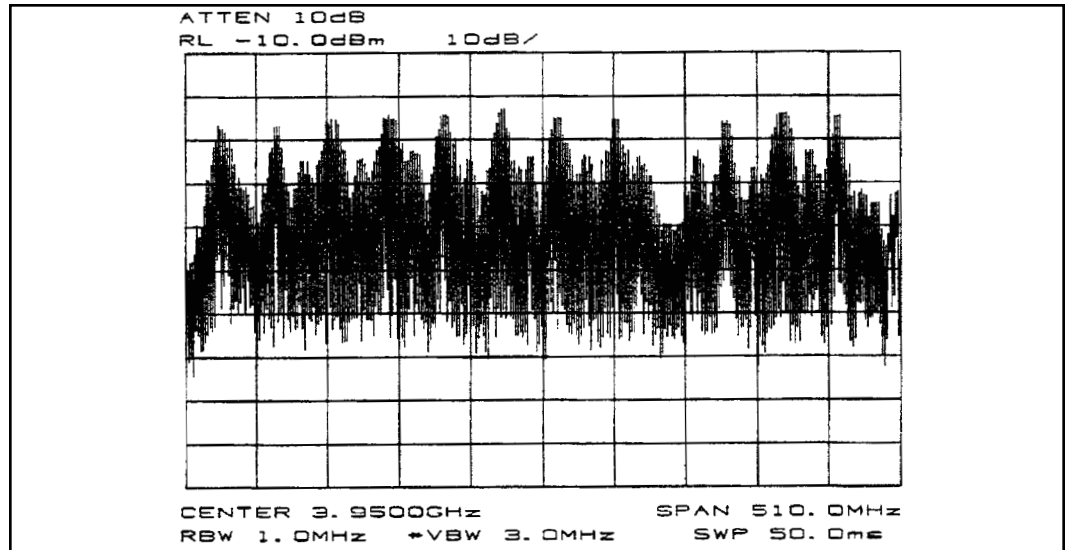

Figure 4-5: Maximizing Odd Transponders

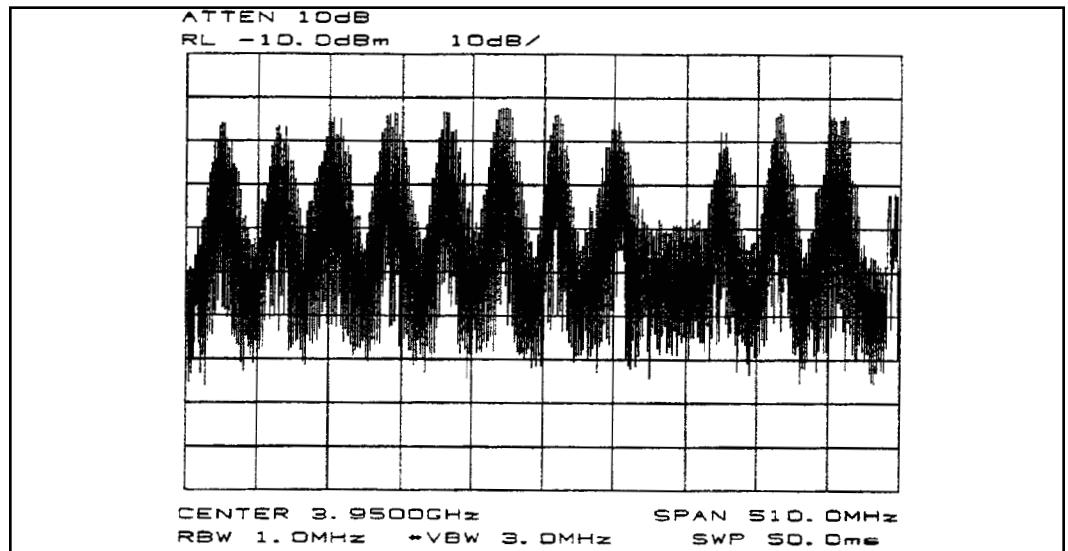

Figure 4-6: Optimum Polarization Setting

Subreflector Adjustment

After the satellite has been acquired and testing has taken place with the spectrum analyzer, the subreflector may need to be adjusted to maximize optimum performance of your antenna. The following procedures should be followed if a subreflector adjustment is required to maximize optimum performance.

NOTE: All INTELSAT Type Approved antennas do not require subreflector adjustment.

Before proceeding, azimuth and elevation patterns should be conducted to determine the adjustments that need to be made. The goal is to achieve a high peak on the main lobe and even distances between the main lobe and sidelobes as shown in Figure 4-6.

NOTE: No adjustments should be made in the receive band.

If your pattern dictates a need to adjust the azimuth angle (the left sidelobe requires adjustment), the west side of the subreflector should be adjusted outward by loosening the screws on the subreflector and adjusting the left side outward. An easy way to remember this adjustment feature is through the acronym WOLD (West Out Left Down).

If your pattern dictates a need to adjust the elevation angle (the right sidelobe requires adjustment), the bottom side of the subreflector should be adjusted downward by loosening the screws between the subreflector and the struts and adjusting the bottom side of the subreflector downward. An easy way to remember this adjustment is through the acronym BOLD (Bold Out Left Down).

Each of these adjustments should be repeated until each sidelobe is of equal distance from the peak of the mainlobe.

After the BOLD and WOLD adjustments have been made, it may be necessary to adjust the main lobe. The goal is to achieve a high null depth (distance between lower intersection of sidelobes and top of main lobe) as shown in Figure 4-6.

In order to adjust the main lobe pattern characteristics **ALL** subreflector adjustment screws should be adjusted at the same degree (Note: Because the azimuth and elevation adjustments have been set, it is very important that the null depth adjustment be carefully conducted. Be careful not to alter any previous adjustments that have been made to the subreflector. Follow the procedure listed below when adjusting the null depth of the main lobe.

C-band feeds - Adjustment screws are 3/4 X 10. Move 1 turn per 1dB of imbalance.

Ku-band feeds - Adjustment screws are 1/4 X 20. Move 1 turn per 1 dB of imbalance.

All adjustments should be continued until the desired pattern is achieved. Upon completion the antenna should be properly aligned with the satellite for maximum performance.

Preventive Maintenance

Overview

This section contains periodic preventive maintenance instructions for the 5.6-Meter Earth Station Antenna. Included in this section are inspection and preventive maintenance procedures including cleaning and lubrication, painting, and an operational voltage/current checkout procedure deemed within the capabilities of the average station technician. Refer to applicable vendor manuals for any repair procedures not included in this section yet designated as capable of being performed in the “field” rather than requiring specialized facilities, tools, and/or test equipment as well as technically trained personnel.

An operational checkout procedure provides an accurate indication of the overall earth station performance and should be performed at intervals of approximately three months. This procedure is essentially performed during the various modes of normal operation of the earth station. In addition, the operational checkout procedure should be performed after any repairs or adjustments have been made, or whenever the earth station is suspected of degraded operation. If any discrepancy in performance exists and the condition cannot be readily remedied to return the earth station to a proper operating condition, the appropriate troubleshooting procedures should be referenced to locate the fault. After the trouble is determined and the repairs affected, a final operational checkout procedure should be performed to verify that all discrepancies have been corrected.

The following paragraphs describe the inspection and preventive maintenance procedures for the earth station. These instructions include general cleaning and inspection, the preservation of metal parts and lubrication. Periodic replacement of assemblies or components as a preventive measure is not required. Malfunctions of the earth station can be traced to components, assemblies, and parts through the use of applicable troubleshooting procedures.

General Cleaning

To prevent the excessive accumulation of dust and dirt as well as the removal of such contaminants, thoroughly clean the equipment whenever visually inspecting the earth station components. No special cleaning procedures are required. However, a thorough cleaning in accordance with the following procedures is required to assure continued trouble-free operation.

Electrical Parts

Minor cleaning, such as the removal of dust and loose foreign particles can be accomplished by one of the following:

- Vacuuming
- Using a soft brush or lint-free cloth
- Blowing out the dust and dirt with low pressure (5 to 25 psi), dry compressed air

When using air to blow off the contaminants, either avoid or be careful when directing the air stream on delicate parts. To remove imbedded dirt, grease, or oil from electrical parts; use a 50 percent solution of isopropyl (rubbing) alcohol and apply with a soft bristle brush. It may be necessary to brush some parts vigorously with a stiff bristle brush to remove imbedded and hardened dirt particles. If possible, avoid excessive use of cleaning solvent on electrical insulation. After cleaning, allow the cleaned parts to dry for 10 to 15 minutes before placing the equipment into operation.

Clean mechanical parts by first removing dust, dirt, and other loose contaminants with a

Mechanical Parts

scraper, stiff brush (bristle or wire in the case of rust or other corrosion), or cloth or compressed air at 25 to 40 psi. Any accumulated imbedded dirt, corrosion, grease, or oil deposits that require further cleaning may be removed with a bristle or wire brush and a cleaning solvent such as trichlorethylene or equal. After cleaning, allow cleaned parts to dry for 10 to 15 minutes before placing the equipment into operation.

Inspection

The frequency of inspection is contingent upon the user's individual standards and the operational environment in which the earth station is located. However, a visual inspection of the earth station components should be performed at least semi-annually. Where there are no established wear limits, perform a visual inspection to locate worn or damaged parts which could cause improper functioning of the earth station. It is recommended that the mechanical and electrical inspection be performed on the assembled or partially disassembled equipment to determine the extent of disassembly required prior to completely disassembling a suspected malfunctioning component or module. In the absence of any special inspection requirements, operational tests are the most effective means in isolating parts and assemblies requiring further inspection. Any condition noted during inspection that may preclude continued proper operation of the earth station prior to the next scheduled inspection should be noted. The discrepant condition should be corrected (repaired or replaced) immediately or at the conclusion of the inspection procedure.

Local Control/Motor Drive Controller

Inspection of the local control/motor drive controller conforms generally to standard visual inspection procedures on electromechanical equipment. In addition to these standard procedures, perform the following checks and visual inspections for the specific conditions noted:

- Check the front panel for illegible and indistinct panel markings.
- Check the three position selector switches (Azimuth Off/Slow/Fast, Elevation-Off/Slow/Fast, and Polarization-CCW/Off/CW) for smooth operation, audible clicking at each actuation (left to center and return) and spring return from right to center. For each of the two position selector switches (Azimuth-East/West, Elevation-Up/Down, and Local/Remote) check for smooth operation and audible clicking at each actuation.
- Inspect all wiring and cables for discolorization and burned insulation, dirt, breaks, security of connection and other signs of deterioration. Examine connections for dirt, flux, corrosion, and mechanical defects. Check for loose or broken lacing and cut, brittle, abraided, frayed, or cracked insulation.
- Examine connectors for corrosion, broken inserts and stripped threads. Check connector shells for distortion and dents, and contact pins for bends, misalignment, or other deformities. Check connector inserts for carbon tracking indicating arc-over.
- Check all electrical components for dirt, cracks, chips, breaks, discoloration and other signs of deterioration and damage. A discolored, blistered, or burnt condition is evidence of overload. Measure actual value of suspect electrical components and compare against specified value.
- Check transformer for an excessive wax deposit on the surface, discoloration, or a

pungent odor indicative of burning varnish denoting overheating or a total breakdown.

- Check all terminal boards for broken or missing terminals and stripped threads. Check tightness of lead attaching hardware.
- Check each starter for a make-after-break provision through the release of one pushbutton as the alternate pushbutton is pressed.
- Check the relays and contactors for free operation of the armatures and contact condition. The contacts are usable even though pitted, burned, worn, or discolored. The contacts or contactor or relay assembly should be replaced only when the contact material has been completely torn away or worn off.
- Visually inspect all mechanical parts for freedom of operation without binding or interference. Check for security of all hardware and stripped or otherwise damaged threads. Check metallic parts for corrosion, dents, distortion, and other deformation.
- Check for evidence of water inside the enclosure. If any water is in evidence, check that all seals are intact and if not, use a coating of RTV-108 (silicone rubber sealant) to seal any exposed electrical fitting, bolt hole, or other possible water entry to the enclosed electrical components in order to maintain a waterproof condition.
- Check or change humidity absorber.

Antenna

Inspection of the antenna conforms generally to standard visual inspection procedures performed on electromechanical equipment. In addition to these procedures, perform the following checks and visual inspections for the specific conditions noted:

- Inspect all wiring and cables particularly the network to enclosure and enclosure to mount interfaces for discoloration and burned insulation, moisture entry, corrosion, dirt, breaks, security of connection, and other signs of deterioration. Examine connections for dirt, corrosion, and mechanical defects. Check for loose or broken lacing and cut, abraided, frayed, brittle, and cracked insulation.
- Examine connectors for corrosion, broken inserts and stripped threads. Check connector shells for distortion and dents, and contact pins for bends, misalignment or other deformities. Check connector inserts for cracks, and carbon tracking, burns or charring indicating arc-over.
- Check all electrical component for dirt, cracks, chips, breaks, discoloration, and other signs of deterioration and damage. A discolored, blistered, or burnt condition is evidence of overload.
- Operate the azimuth and elevation drives as well as the feed rotation in both the plus

and minus direction from the local control/motor drive controller at least once every three months during antenna down time. Check the mechanical limit switches provided at the end points stop antenna and feed movement, and limit travel to prevent structural interference and damage. Check the mechanical limit switches for corrosion and water entry and the arm on each feed limit switch for free movement without binding. Be certain both feed rotation limit switch arms are not distorted and ride centrally on the actuating cam to open their corresponding limit switch.

- Inspect the azimuth and elevation jackscrew boots for security of attachment at both ends, for abrasion, tears, cuts, brittleness and other damage that may expose the jackscrew to the environment (water, dust, etc.). Minor repairs can be made with RTV-108 silicone rubber sealant.
- Visually inspect the feed window for dirt and the feed, feed supports, feed window, and reflector for distortion, foreign object damage and environmental deterioration due to ice and snow, dust, rain, hail, and high winds, etc. which may cause electrical component and/or structural deformation.
- Check the cable attachment to the resolvers and to the LNA or LNB's and enclosure mount interface for security, the cable routing for secure hanger attachment and the cable insulation for cuts, cracking, abrasion, and other deterioration. Check the LNA or LNB's and the resolvers for a secure mechanical attachment. Ensure proper torquing of polarization drive gear box setscrews and appropriate tensioning of corresponding drive chain assembly, if applicable.
- Check (if applicable) that the drain holes in the bottom of the enclosure are not obstructed and there is no evidence of water accumulation. Check the enclosure doors for proper closure and that the door seals are intact, not torn, abraded or otherwise damaged. Check that all other seals are intact and if not, use a coating of RTV-108 (silicone rubber sealant) to seal any exposed electrical fitting, bolt hold, or other possible water entry to electrical components in order to maintain a weatherproof condition. If the enclosure is provided with a vent fan, check for free operation of the fan blade. The fan bearings are permanently lubricated; any binding, abnormal noise or vibration necessitates replacement of the fan assembly. Check and replace the fan filter element if it appears dirty or obstructed with dust.
- Check for the appearance of surface lubricants that will cause the accumulation of dirt and grime. Clean off all excess surface lubricants with a cloth and if required, a cloth dampened not wetted with trichlorethylene, or equal.
- Visually inspect all mechanical parts for freedom of operation with no misalignment, binding or interference. Check all cabling for sufficient slack to prevent cable strain as well as adequate restraint to prevent abrasion or chaffing during antenna and feed movement.
- Check security of antenna mounting and interconnecting assembly hardware. Be cer-

Drive System Voltage and Current Checks

tain all electrical grounding connections (including cross-axis grounding straps) are intact and secure, not corroded or broken. Thoroughly clean any noticeable corroded portions of grounding cables, unplated portion of universal terminals and corresponding mounting surfaces using a wire brush. Replace rather than tighten any loose A-325 structural hardware. The hardware distorts at initial installation and once loosened will not maintain the required high strength friction connection. All other assembly and installation hardware should be tightened to its original torqued condition. When installing new structural hardware, do not use a wrench with a lever arm longer than two feet.

- Examine painted aluminum and galvanized surfaces and touch-up where required.

At the conclusion of the installation procedure prior to turning the system over to the station facility, an installation acceptance check off sheet was prepared and duly signed off if installed by Andrew crew. Part of this check off included voltage readings retaken to determine if proper voltage was available. Current readings were also taken as a reference for future comparison to serve as a troubleshooting aid in determining possible equipment degradation and shortened life. Any current reading taken during the following procedure that varies by more than five percent from the pre-established reference values necessitates troubleshooting the particular system involved to determine the cause and required corrective action.

Step 1

Approximately every three months and during a period of down time, disconnect as applicable the RF transmitter and all power supplies. The main disconnect switch in the main load center box at the antenna site must be in the ON position and the LOCAL/REMOTE switch in the local control motor drive controller must be in the LOCAL position.

Step 2

Open the outer local control/motor drive controller door at the antenna site to gain access to the conductors supplying power to the azimuth, elevation, and polarization drive motors.

NOTE: During the following procedures, the antenna drives (azimuth, elevation, and polarization) will be powered to rotate the antenna and feed in both directions of travel. Check that this condition can be tolerated from a safety as well as an operational standpoint, and that the electrical limits are not reached before the testing is concluded. Reaching an electrical limit before concluding a test necessitates rotating the antenna or feed in the opposite direction a sufficient distance to permit retesting in the desired direction.

Step 3

Turn the FEED CCW/OFF/CW switch to either the CW or CCW position and while the feed is rotating, carefully use a clamp on ammeter in accordance with the ammeter manufacturer's instructions to take current readings off each of the three conductors (phases) connected to the load side of the polarization motor circuit breaker. Record the current draw in the equipment log and compare the readings to the reference values entered in the installation/acceptance check off. If the readings differ by more than five percent, refer to appropriate troubleshooting information and perform applicable corrective action. Then take voltage readings off each of the three conductors; the readings should agree with each other within two percent. Turn the FEED CCW/OFF/CW switch to OFF. Repeat preceding step (3) with the FEED CCW/OFF/CW switch in the alternate operating position.

Step 4

Turn the AZIMUTH EAST/WEST switch to either position and while the antenna is rotating, carefully use a clamp on ammeter in accordance with the ammeter manufacturer's instructions to take current readings off each of the three conductors (phases) connected to the load side of the azimuth drive motor circuit breaker. Record the current draw in the equipment log and compare the readings to the reference values entered in the installation/acceptance check off. If the readings differ by more than five percent, refer to appropriate troubleshooting information and perform applicable corrective action. Then take voltage readings off each of the three conductors; the readings should agree with each other—within two percent. Turn the AZIMUTH switch to OFF.

Step 5

Repeat steps (5) with the AZIMUTH EAST/WEST switch in the alternate operating position.

Step 6

Turn the ELEVATION DOWN/UP switch to either position and while the antenna is rotating, carefully use a clamp on ammeter in accordance with the ammeter manufacturer's instructions to take current readings off each of the three conductors (phases) connected to the load side of the elevation drive motor circuit breaker. Record the current draw in the equipment log and compare the readings to the reference values entered in the installation/acceptance check off. If the readings differ by more than five percent, refer to appropriate troubleshooting information and perform applicable corrective action. Then take voltage readings off each of the three conductors; the readings should agree with each other within two percent. Turn the ELEVATION switch to OFF.

Step 7

Repeat steps (7) with the ELEVATION DOWN/UP switch in the alternate operating position.

Step 8

If all voltage and current readings are within tolerance, close the local control/motor drive controller inner door and place the LOCAL/REMOTE switch in the REMOTE position to return antenna control to the studio. Then close and lock the outer local control/motor drive controller door.

Step 9

When preserving the component parts, refer to the following paragraphs in this section.

Preservation of Component Parts

Aluminum Parts

Remove all loose paint and corrosion by scraping, wire brushing, or using steel wool. If using steel wool near the feed window, make sure that none remains on the feed horn window. Edges of existing paint can be blended with the metal surface by using a fine grit sandpaper. Wipe the surface to be painted with a soft rag dampened in trichlorethylene, lacquer thinner or equal. Be certain to remove all loose paint, corrosion, imbedded dirt, grease, and oil deposits or the paint will not adhere to the surface. Lacquer thinner will dissolve paint if applied heavily and rubbed vigorously. The reflector may be washed with plain water if necessary. Do not use bleach, soap solutions, or kerosene as it is difficult to remove the residue. Allow the cleaned surface to dry thoroughly before priming.

Prime the cleaned surface by applying zinc chromate primer. The primer can be applied with a brush, roller, or pressurized spray. If necessary, thin the primer with lacquer thinner to the proper consistency. Feather primer onto adjacent painted surfaces;. Allow primer to thoroughly dry before applying the finish paint coat.

Paint all RF surfaces, such as the inside of the main reflector and subreflector with a high-reflectance white paint. This type of paint disperses light rays, reducing the focusing effect of the sun's radiation, thereby reducing heat build-up caused by the focused sun's rays on the feed system. Rear surfaces of the reflector and subreflector may be painted with a flat white enamel paint. The paint can be applied with a brush, roller, or pressurized spray. If necessary, thin the paint with the appropriate thinner to the proper consistency. Thoroughly paint over the primed surfaces and blend with the existing painted surface.

Galvanized Surfaces

Remove all loose paint and corrosion by scraping, wire brushing, or using steel wool. Edges of existing paint can be blended with the metal surface by using a fine grit sandpaper. Wipe the surface to be painted with a soft rag dampened in trichlorethylene, lacquer thinner, or equal. Be certain to remove all loose paint, corrosion, imbedded dirt, grease, and oil deposits or the paint will not adhere to the surface. Lacquer thinner will dissolve paint if applied heavily and rubbed vigorously. Do not use bleach, soap solutions, or kerosene as it is difficult to remove the residue. Allow the clean surface to dry thoroughly before painting.

Paint the cleaned surface with a zing-rich paint. The paint can be applied with a brush, roller, or pressurized spray. If necessary, thin the paint with the appropriate thinner to the proper consistency. Thoroughly paint over the cleaned surface and blend with the existing painted surface.

Lubrication

For long life and trouble-free operation be certain not to extend the lubrication schedule beyond the frequency recommended in the Lubrication Chart. The frequency should be shortened if the antenna is subjected to an adverse environment (e.g., high temperature, extended periods of rainfall, high humidity, dust storms, etc). Any component or part should be immediately be lubricated if during inspection or operation, rough, jarring, or intermittent motion is noted, or if squeaky or other unusual noises are heard. Lubrication is required on all metal-to-metal rolling or sliding parts. Use the lubricants recommended. Do not over lubricate. Over lubrication can often be as damaging as under lubrication. Prior to the application of lubricant to any parts, use a clean cloth and/or bristle brush and remove any old lubricant to prevent an excessive build-up. Remove indicated access plugs from square tube weldment and apply lubricant to panning frame

tube assembly and corresponding thrust pads. Securely replace access plugs in square tube weldment. Be certain to remove any protective caps and clean off each lubrication fitting prior to injecting fresh grease. The elevation and azimuth jackscrew assemblies are equipped with a grease fitting and corresponding pipe plug on opposite sides of the jack housing. Remove the appropriate pipe plug and fill with with grease until lubricant seeps from the pipe plug opening. Replace and securely tighten pipe plug.

The following is a list of the lubricant characteristics:

- Mobil Temp SHC32 A non-soap hydrocarbon fluid type grease. Operating temperature range is -65 degrees to 350+ degrees Fahrenheit (-54 degrees to 177+ degrees Celsius).
- Mobil SHC624 A low temperature synthetic oil for worm gear reducers. Operating temperature range is -40 degrees to 125+ degrees Fahrenheit (-40 degrees to 52+ degrees Celsius).
- Moly Grease A grease lubricant containing molybdenum disulfide. Operating temperature range is -85 degrees to 300+ degrees Fahrenheit (-29 degrees to 149+ degrees Celsius).

Periodically inspect lifting screws on jackscrew assemblies to ensure adequate lubrication. Loosen Jackscrew boot clamps to expose the lifting screw assembly. Fully extend jackscrew assembly being careful not to exceed preset mechanical limits. Brush thin coating of Mobil SHC32 grease on exposed lifting screw. Replace boot and attach corresponding boot clamps. If lifting screw is rusty, remove existing lubricant with solvent and wire brush rusted area. Rinse with solvent and apply fresh grease.

Periodically inspect and remove dust or dirt deposits from the motor housings to avoid hindering the heat exchange with the ambient air. Slight dirt accumulation on the air vent screw through splash oil cannot be avoided; however, keep vent screw clean to ensure proper pressure compensation.

Lube points 2, 3, 7 and 8, shown in the Lubrication Chart, require removal of the indicated drain plugs and collecting/measuring the amount of SHC624 drain oil using measuring cup. The specified amount of oil must be added to the gear motor/housing (after installing the drain plug) via the fill/vent plug opening using supplied funnel. Addition of the oil requires use of an appropriate filling utensil. Use of a modified level stick will not correctly gauge the appropriate amount of oil in the gear housings.

Lube Point	Parts to be Lubricated	Action	Frequency	Service Type	Lube Type	Quantity /Points	Andrew Number
------------	------------------------	--------	-----------	--------------	-----------	------------------	---------------

Jackscrews/Motors

Gear Motor/Housing Fill Drain Requirements

Lubrication Chart

Lube Point No.	Components to be Lubricated	Frequency (Months)				Type of Service	Type of Lube	No. of Lube Points or Quantity
		1	3	6	12			
1.	Elevation Jackscrew Housing		X			Pressure Fitting	SHC32	1
2. ¹	Elevation Jackscrew Gear Housing Fill and Drain			I*	C**	Pipe Plugs	SHC624	10 Oz
3. ²	Elevation Drive Intermediate Gearbox Fill and Drain	I*	C**			Pipe Plugs	SHC624	34 Oz.
4.	Elevation Jackscrew Pivot Pin, upper		X			Pressure Fitting	SHC32	1
5.	Azimuth Jackscrew Pivot Pin, front		X			Pressure Fitting	SHC32	1
6.	Azimuth Jackscrew Housing		X			Pressure Fitting	SHC32	2
7. ¹	Azimuth Jackscrew Gear Housing Fill and Drain	I*	C**			Pipe Plugs	SHC624	4 Oz.
8. ²	Azimuth Drive Intermediate Gearbox Fill and Drain			I*	C**	Pipe Plugs	SHC624	34 Oz.
9.	Polarization Drive Gear			X		Brush	SHC32	Minimum Surface Coverage
10.	Feed Rotation Worm Gear Pillow Blocks			X		Pressure Fitting	SHC32	2

X = Lubricate I = Inspect C = Change

* Inspection requires checking for visible signs of oil leakage, draining replacing and adding oil to ensure appropriate oil level requirements. Excessively dirty oil will require fresh oil replacement. If oil leakage is found to be excessive, refer to appropriate troubleshooting information and perform applicable corrective action. Periodic inspection procedures can be less frequent after first or second scheduled inspections.

** Initial oil change requirements include flushing gear boxes with a standard cleaning agent.

1 Type 'HS' and 'STHS' drives only. 10 oz. required for gearbox on Type 'MS' drives.

2 Type 'HS' and 'STHS' drives only.

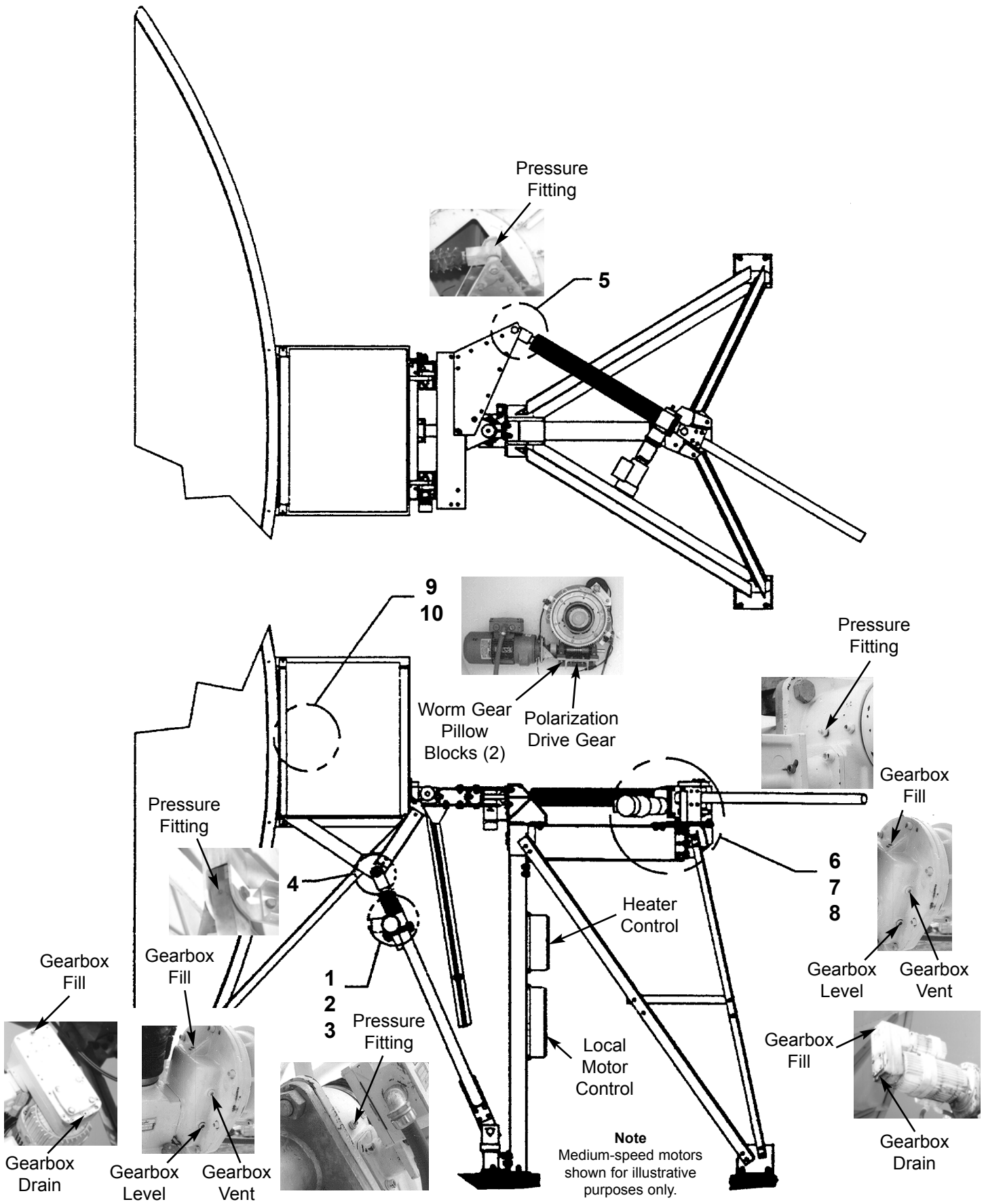

High-Speed Antenna Lubrication Points

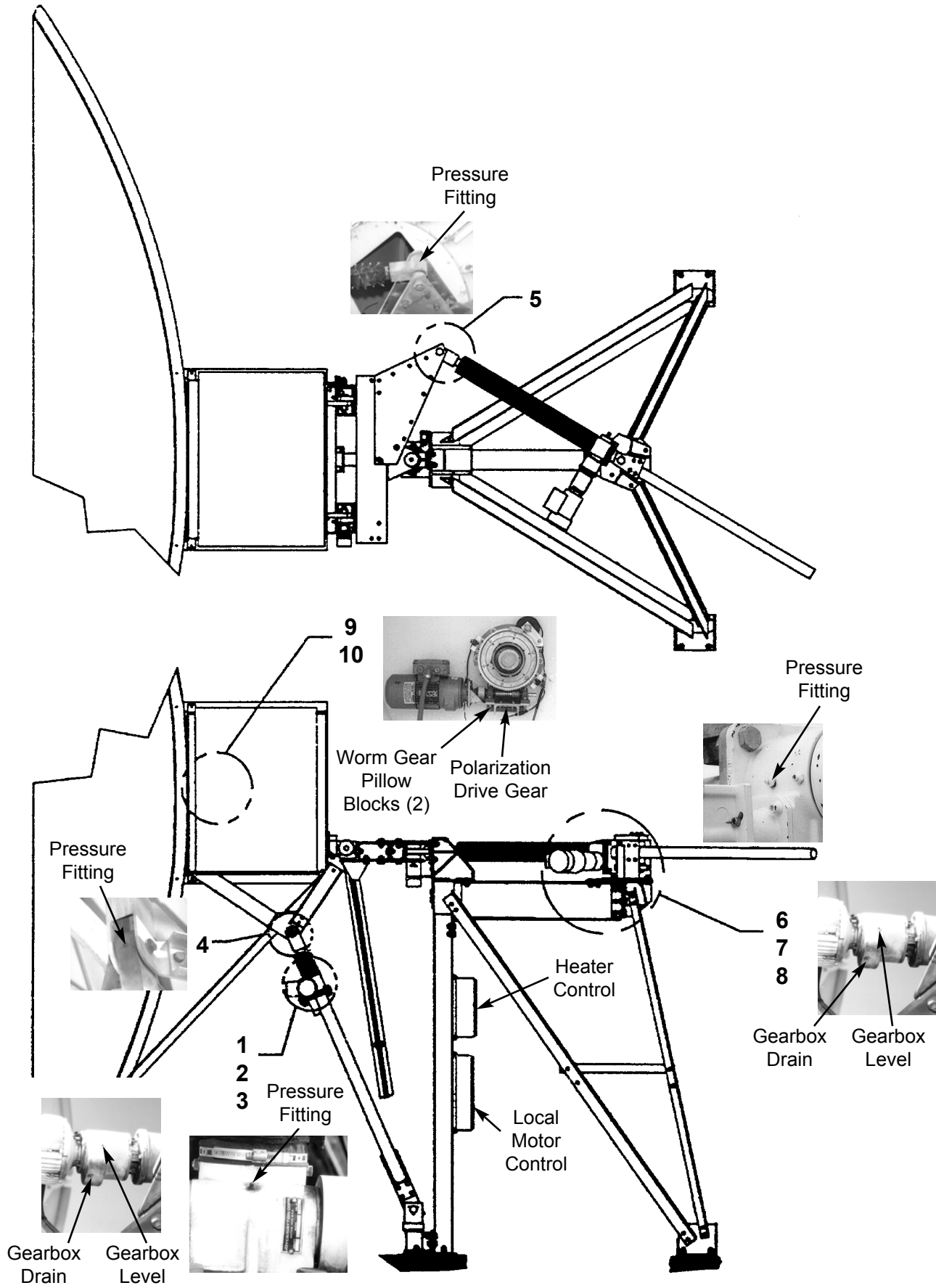

Medium-Speed Antenna Lubrication Points

Free Manuals Download Website

<http://myh66.com>

<http://usermanuals.us>

<http://www.somanuals.com>

<http://www.4manuals.cc>

<http://www.manual-lib.com>

<http://www.404manual.com>

<http://www.luxmanual.com>

<http://aubethermostatmanual.com>

Golf course search by state

<http://golfingnear.com>

Email search by domain

<http://emailbydomain.com>

Auto manuals search

<http://auto.somanuals.com>

TV manuals search

<http://tv.somanuals.com>