

4. March 2004

OWNER 'S MANUAL

Now, as always, speakers form the most important link in a stereo and home theater system. There-fore, they should be positioned and connected with care. It is our hope that the information contained within this manual will help you in setting up your new speakers so that they may provide you with many years of listening pleasure.

Your Vienna Acoustics Team

ATTENTION:

Please read these instructions carefully and completely, since they are very important to ensure the best performance and the long-term problem-free operation.

Make sure you have received with BERG or WEBERN your choice of the wall-mounting bracket or stand for free-standing positioning, which are both packed separately. A spike stand for free-standing positioning is included with SCHÖNBERG.

ROOM TREATMENT

Good sounding rooms have a well-balanced acoustic. This does not mean that your home needs to look like a recording studio.

Commonly found furnishings such as bookshelves, carpeting and furniture all exhibit beneficial amounts of absorption and dispersion. Rooms with little furniture, carpeting or other surfaces will demonstrate poor damping and will produce a hard, bright sound.

For the Aluminium Line, as with any loudspeaker, we recommend trying different positions for the speakers, as subtle changes in placement can make a significant difference in sound. For example, changes in the angle of a speaker toward the listening position can produce significant improvements in performance.

And while the Aluminium Line has been designed to perform at its best in close proximity to the wall behind the speakers, when not using the wall mounting option, experimenting with small changes in this distance to the back wall can result in improved bass performance.

In general, you should start with the tweeters positioned to the inside, toward each other. However, experimentation with the tweeters positioned on the outside may prove beneficial for improved performance in some installations.

It is also recommended, that the area around your speakers remain uncluttered, allowing for unob-structed dispersion of the audio signal.

Please give the speakers around 30 hours of initial playing time prior to critical listening. As with any loudspeaker, playing time is required to allow both mechanical and electrical devices in the loudspeaker to break-in.

POSITIONING SCHÖNBERG

Room acoustics and positioning of a speaker within the room have an important effect on sound quality.

SCHÖNBERG features an adjustable spike stand for perfect decoupling and stability. It was developed for optimum sonic results at a distance of 0 – 40 cm (0 – 15 inches) from the wall.

POSITIONING WEBERN & BERG

A. On wall application:

Wall mounting is allowed by an ingenious aluminium

mounting device, unrivalled in its ability to provide the best environment for superior sound quality.

Three positions are afforded by this bracket, enabling the speaker to be angled toward the listening positioning for best performance.

The bolts that fix the angled position presses the cabinet against a rubber decoupling device, there-fore damping and silencing the interface point between wall and speaker.

This prevents detrimental resonance from being transferred between wall and speaker.

Additionally, this wall-mounting device allows not only for vertical but also for horizontal positioning, allowing WEBERN & BERG to be used as a center speaker with a plasma-television or under a screen used with a video projector.

B. Stand alone application:

Alternatively, for those who do not wish to mount the speaker to the wall, an ultra-rigid aluminium stand is offered, which was developed for optimum sound when place on a surface such as a bookshelf or desktop. The bottom of the stand is coated with a layer of isolation material designed to both protect the surface on which the speaker is placed and to provide a superior interface between speaker and mounting surface for improved performance. The stand serves both tweeter left and tweeter right positions.

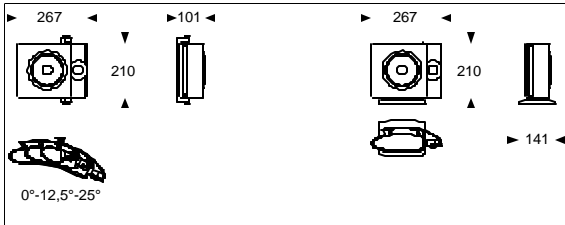
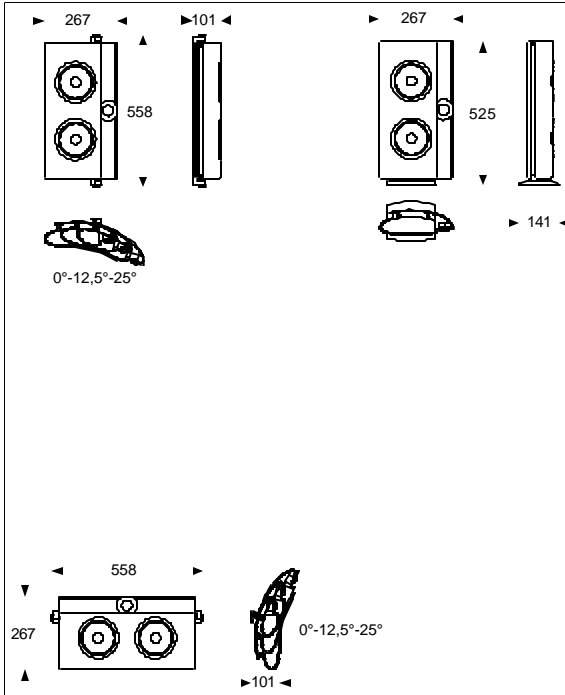

MOUNTING WEBERN & BERG

A. On wall application:

To prepare the speakers for wall mounting:

1. Please put on the enclosed gloves to avoid fingerprints.
2. Remove the aluminium inlays on the top and bottom of the speakers. As they are attached with magnets, they simply lift off.
3. Put the matching wall-mounting inlay on each speaker, so that the two holes for the two bolt sockets line up.

ATTENTION:

The two inlays are slightly different for use on each of the respective sides. In order to mount the inlays correctly the three conical milled points must be visible and the mounting bolts are able to be inserted.

4. Now attach the appropriate inlay with the two bolts, by using the hexagon-tool (Allen wrench/ key).
5. Now turn the speaker over and execute the same procedure.

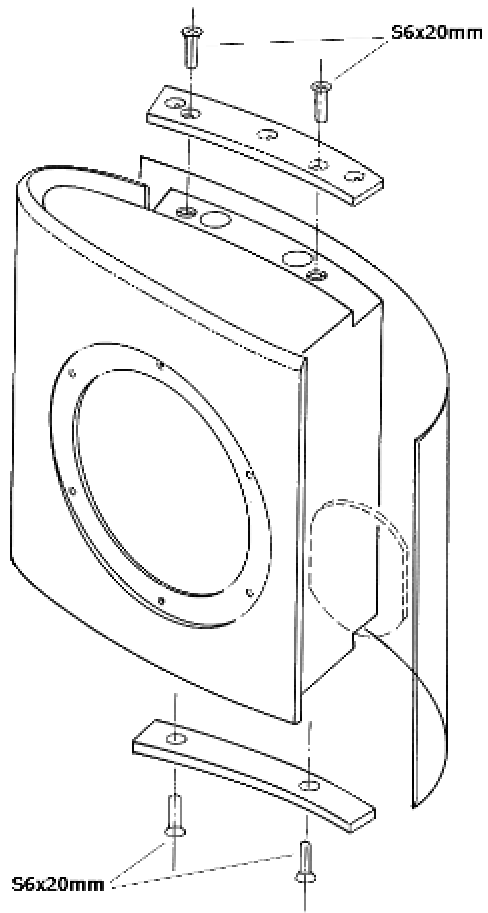

To attach the wall-mounting device to the wall:

ATTENTION:

For best performance, it is recommended that the speakers be angled toward the listening position. This means that special attention must be paid when mounting the brackets.

If you have chosen to mount a pair of speakers with the tweeters on the inside, mount the bracket with the thin flat profile to the inside. If mounting a pair of speakers with the tweeters on the outside, mount the bracket with the thin flat profile to the outside.

If you have chosen to use a speaker as a center channel, two position options are allowed, either angled up or down. To angle up, the thin flat profile of the bracket should face up. To angle down, the thin flat profile of the bracket should face down.

1. First mark the position on the wall using the holes of the wall-mounting bracket as a guide.
2. After drilling the holes, put the included anchors (metal for sheetrock or other wall board, or plastic for plaster or concrete wall construction material) into the wall.
3. Now fix the wall-mounting bracket to the wall, by using the provided screws.

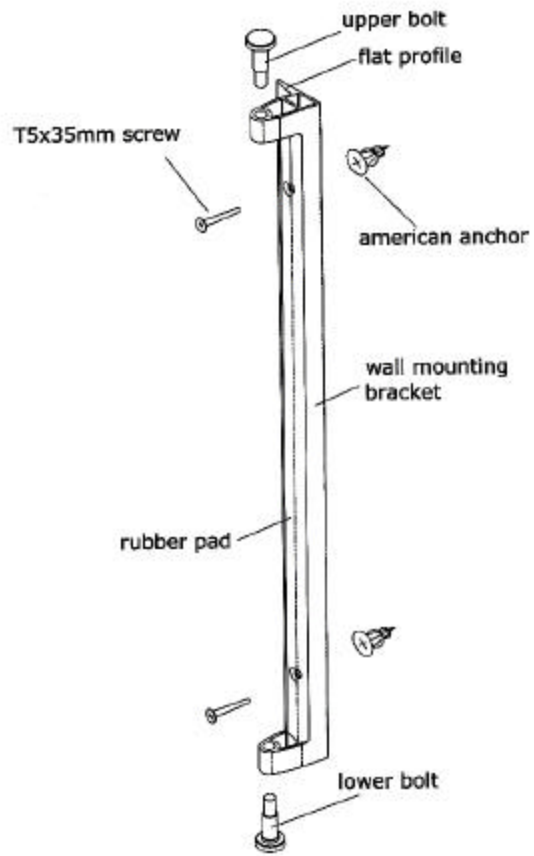

To attach the speaker to the wall-mounting device:

ATTENTION:

As both WEBERN or BERG are symmetrical in driver orientation (having not top or bottom) selecting an orientation position for the speakers so that the tweeters face in or out, as well as up or down, can be done to suit the nature of each installation. It is recommended that experimentation take place to determine which orientation of the tweeters results in optimal performance.

1. Please put on the enclosed gloves to avoid fingerprints.
2. Insert the lower conical tipped bolt inside the wall-mounting bracket completely with the hexagonal tool (Allen wrench/key). [For center positioning simply start with whichever side is most convenient.]

ATTENTION:

The accessories box includes two plastic sockets, which you can put on the conical point of the bolts to avoid scratching the inlays. Once the preferred position is found, they can be removed.

3. After you have chosen a position, place the speaker in away that the lower bolt fits into the chosen conically milled point on the cabinet inlay.
4. Press the speaker against the rubber-pad and

attach the speaker to the bracket by tightening completely the upper conical tipped bolt with the hexagonal tool (Allen wrench/ key). Please make sure that you use the same conically milled point on both, lower and upper, inlays.

ATTENTION:

For safety reasons it is recommended that all connection bolts be tightened every six months.

B. Free-standing application:

Connecting the speakers to the aluminium stands
(please see drawing):

ATTENTION:

Usually, you want the tweeters to look in two different directions. In this case, you have to act as follows:

1. Please put on the enclosed gloves to avoid fingerprints.
2. Put your pair of speakers in front of you in a way that the tweeters are to the inside.
3. Pull out the inlay of each speaker. Since they are attached with magnets, they simply pull off.

4. Put the spacer bars on the two speakers, so that the holes (two in each bar and two in each speaker) for the two bolts match.

5. Put the attached bases on the spacer bars, so that now all holes (two in each speaker, two in each spacer bar and two in each base) match.

ATTENTION:

The Vienna Acoustics logo on the base faces the front.

6. Now attach the stand by completely tightening the two supplied bolts using the hexagonal tool (Allen wrench/key).

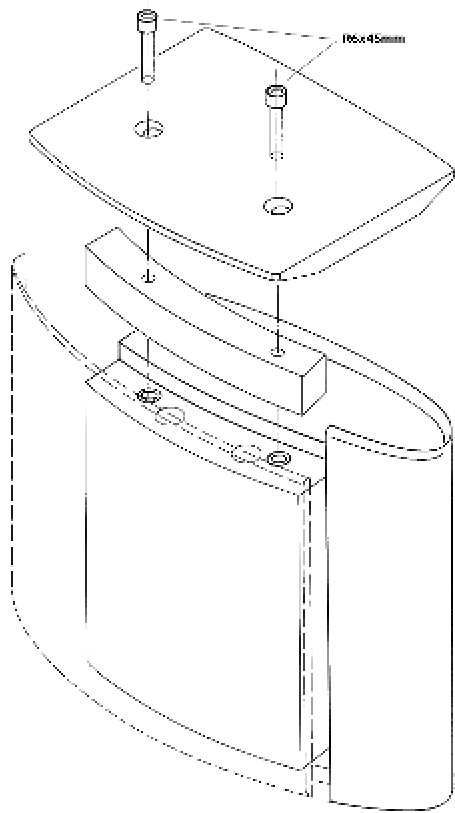

**ACCESSORIES FOR WEBERN & BERG FREE
STANDING BRACKET:**

BRACKET: 1 pc.

SPACER BAR: 1 pc., for connection between the speaker and the bracket.

BOLTS: 2 pcs. M6 x 45 mm

HEXAGONAL TOOL (Allen wrench/key): 1 pc.
for adjusting the bolts.

BANANA PLUGS: 2 pcs., silver plated, short version for convenient connection of speaker cables.

GLOVES: 2 pcs.
for protecting the speaker against fingerprints.

**ACCESSORIES FOR WEBERN & BERG WALL
MOUNTING BRACKET:**

WALL MOUNTING DEVICE: 1 pc.
for on-wall application.

WALL-MOUNTING INLAY: 2 pcs., to place on the speaker for attaching wall-mounting bracket.

BOLT: 2 pcs.
for connecting the cabinet with the wall mounting bracket.

PLASTIC SOCKETS: 2 pcs.
to avoid scratches when inserting and adjusting bolts.

BOLTS: 4 pcs. M6 x 20 mm
for attaching the inlays to the cabinet.

HEXAGONAL TOOL (Allen wrench/key): 2 pcs.
for adjusting the screws and bolts.

METAL WALL MOUNTING ANCHORS AND SCREWS (for mounting in sheetrock or other wall board wall construction material): 2 pcs.

PLASTIC WALL MOUNTING ANCHORS AND SCREWS (for mounting in plaster or concrete wall construction material): 2 pcs.

LOGO: 1 pc.
for placing on the grill or speaker, depending on the orientation of the speaker in each application.

BANANA PLUGS: 2 pcs.
silver plated, short version for convenient connection of speaker cables.

GLOVES: 2 pcs.
for protecting the speaker against fingerprints.

CABINETS

To ensure the best possible appearance, the surface of the aluminium line is treated with the highest grade of aluminium processing.

After being precisely machined and CNC milled, all aluminium parts are bead blasted and transparently anodized.

To maximize internal volume, we profited from the stiffness of aluminium to realize a slim walled cabinet. Furthermore, the aluminium panels are curved to optimize both stiffness and freedom from resonance, which is so crucial for natural sound. This curve means that while the average depth of the speaker is 50 mm (2 inches), it reaches a maximum point of 84 mm (3.3 inches) in the center of the arch.

The extra available space in the middle of the cabinet allows for the use of physically deeper pure high-end mid-bass drivers. An additional benefit of the speakers' shape is the lack of parallel walls, which avoids internal standing waves from adversely affecting performance.

In extensive research we found out that it is vital not to use a single enclosed form in creating the box, but to break the cabinet into two separate elements connected by MDF, with additional damping strips between the MDF and the aluminium, in order to completely eliminate deleterious cabinet resonance.

CONNECTIONS

All connections must be complete and secure, since poor contact between speaker cable and input connector can lead to degradation of sound quality.

The speakers come with a set of two silver plated banana plugs in which the speaker wire is inserted and held in place by screwing down the insert post.

For the aluminium line we use silver plated banana connectors that do not oxidize, but contaminants or surface oxidation build-up on your speaker cables and connectors may degrade sound quality.

It is also a good idea to make a point of regularly cleaning all connections in your system since oxidation will build up on a regular basis that can lead to signal degradation.

ATTENTION:

Please pay special attention when handling the cables during hookup of the loudspeaker. It is recommended that the amplifier be turned off while connection to the speaker is made secure, with no stray wires contacting the cabinet.

As with any metal, the aluminium that makes up much of the cabinet is a conductive material. Therefore, a short circuit could result if any bare wire or connector should come in contact with the cabinet.

CABLING

We encourage and recommend the use of high quality speaker cables and believe them to be an important tool for the enthusiast in obtaining maximum enjoyment from their music reproduction system. High quality cabling is a significant tool in the fine-tuning of any audio system.

As with any purchase, listen carefully and allow your ears to guide you. It is beyond the scope of this manual to provide a useful compendium concerning cables, or to make specific brand or model recommendations. A number of high quality magazines do in fact list cable recommendations.

AMPLIFICATION

Our speakers demonstrate outstanding sonic results with a variety of amplifier types. They feature a combination of high efficiency and gentle impedance curves that allow them to be used with either solid state or tube electronics.

However, it is still important to select an amplifier with care since the full potential of your system will only be revealed by quality electronics. Amplifier designs do have distinct and different sounds.

It is important to listen carefully to the match of amplifier and loudspeaker to ensure that the combination works well sonically for you.

Though rated amplifier wattage bears little correlation to either sound quality or drive capability, the user is cautioned that amplifiers of lower power ratings, more frequently than more powerful amplifiers, are particularly prone to producing dangerously significant amounts of distortion as they are stressed beyond their limits.

This distortion can and will damage loudspeaker components. This damage will not be covered under warranty.

BREAKING IN NEW LOUDSPEAKERS

Your loudspeakers contain a large number of precision built moving parts. These parts require playing time initially to develop their maximum smoothness and extension.

Very audible improvements can be observed during about 30 hours of playing. Additional improvements will be evident after 100 hours of playing time, at which point the speakers will have reached their full musical potential.

MAINTENANCE

Your speaker cabinets can be cleaned periodically with a soft, damp cloth. Do not use any chemical detergents. Should spots or stains appear, clear water can be used to gently remove them.

Should the bass drivers become dusty, it is safe to use a soft brush to clean the woofers.

Free Manuals Download Website

<http://myh66.com>

<http://usermanuals.us>

<http://www.somanuals.com>

<http://www.4manuals.cc>

<http://www.manual-lib.com>

<http://www.404manual.com>

<http://www.luxmanual.com>

<http://aubethermostatmanual.com>

Golf course search by state

<http://golfingnear.com>

Email search by domain

<http://emailbydomain.com>

Auto manuals search

<http://auto.somanuals.com>

TV manuals search

<http://tv.somanuals.com>