

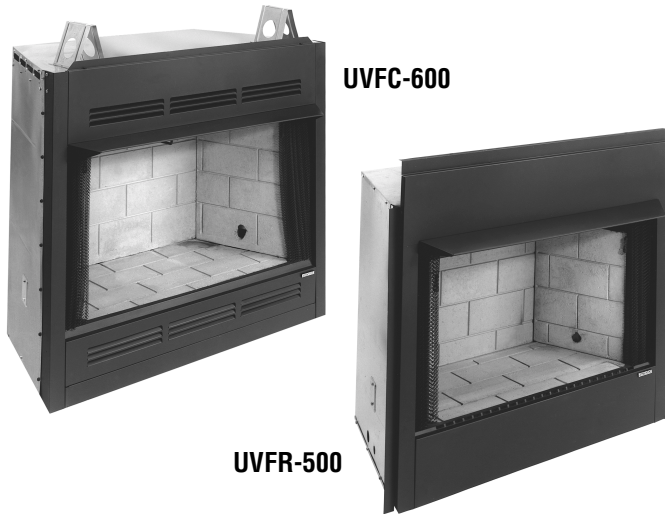

INSTALLATION INSTRUCTIONS

STANDARD SERIES



UVFC-600

UVFR-500

RETAIN THESE INSTRUCTIONS FOR FUTURE REFERENCE



WARNING: IF THE INFORMATION IN THIS MANUAL IS NOT FOLLOWED EXACTLY, A FIRE OR EXPLOSION MAY RESULT CAUSING PROPERTY DAMAGE, PERSONAL INJURY OR LOSS OF LIFE.

FOR YOUR SAFETY: Do not store or use gasoline or other flammable vapors or liquids in the vicinity of this or any other appliance.

FOR YOUR SAFETY: What to do if you smell gas:

- DO NOT light any appliance.
- DO NOT touch any electrical switches.
- DO NOT use any phone in your building.
- Immediately call your gas supplier from a neighbor's phone.

Follow your gas suppliers instructions.

- If your gas supplier cannot be reached, call the fire department.

Installation and service must be performed by a qualified installer, service agency or the gas supplier.

36" & 42" Unvented Fireboxes
P/N 700,018M REV. C 12/2003

MODELS

UVFR-500

UVFC-500

UVFR-600

UVFC-600

FOR USE ONLY WITH DECORATIVE TYPE UNVENTED ROOM HEATERS.

DO NOT BUILD A WOOD FIRE.

WARNING: IMPROPER INSTALLATION, ADJUSTMENT, ALTERATION, SERVICE OR MAINTENANCE CAN CAUSE INJURY OR PROPERTY DAMAGE. REFER TO THIS MANUAL. FOR ASSISTANCE OR ADDITIONAL INFORMATION CONSULT A QUALIFIED INSTALLER, SERVICE AGENCY OR THE GAS SUPPLIER.

WARNING: DO NOT BURN WOOD OR OTHER MATERIAL IN THESE APPLIANCES.

CAREFULLY REVIEW THE INSTRUCTIONS SUPPLIED WITH THE DECORATIVE TYPE UNVENTED ROOM HEATER FOR THE MINIMUM FIREPLACE SIZE REQUIREMENT.

DO NOT INSTALL THE APPLIANCE IN THIS FIREBOX, UNLESS THIS FIREBOX MEETS THE MINIMUM DIMENSIONS REQUIRED FOR THE INSTALLATIONS.

This is an unvented gas-fired heater. It uses air (oxygen) from the room in which it is installed. Provisions for adequate combustion and ventilation air must be provided. Refer to Combustion and Ventilation Air Section, Page 3.

Due to high temperatures, the appliance should be located out of traffic and away from furniture or draperies.

Do not place clothing or other materials on or near this appliance.

IMPORTANT: READ AND UNDERSTAND THESE INSTRUCTIONS COMPLETELY BEFORE INSTALLING YOUR UNVENTED ROOM HEATERS.

TABLE OF CONTENTS

Firebox/Log Set Reference Chart	page 2
General Information	page 2
Inventory	page 2
Tools/Building Supplies	page 2
Important Safety Information	page 2
Codes	page 3
Combustion and Ventilation Air	page 3
Location of firebox	page 4
Clearances	page 4
Assembly Steps	page 5
Gas Line Installation	page 5
Firebox Framing	page 6
UVF-500 Specifications	page 6
Firebox Installation	page 7
UVF-600 Specifications	page 7
Framing Specifications	page 8
Canopy Installation	page 9
Optional Equipment	page 9
Firebox finishes	page 10
Replacement Parts	page 10
Accessories/Components	page 10
Replacement Parts List	page 11



We suggest that our gas hearth products be installed and serviced by professionals who are certified in the U.S. by the National Fireplace Institute® (NFI) as NFI Gas Specialists.
www.nficertified.org

GENERAL INFORMATION

These ventless firebox enclosures are designed to accept all ANSI Z21.11.2 approved Decorative Type Unvented Gas Log Room Heaters. For the appropriate Unvented Gas Log Room Heater model, refer to the chart below. Refer to the installation instructions provided with the log sets for detailed instructions.

The UVFC Series are unvented fireboxes. They feature a self-contained heat-circulating system.

The UVFR Series is a conventional radiant-heat unvented firebox.

This installation manual will enable you to obtain a safe, efficient and dependable installation of your room heater system.

Do not alter or modify the firebox or its components under any circumstances. Any modification or alteration of the firebox system, including but not limited to the firebox and accessories, may void the warranty, listings and approvals of this system and could result in an unsafe and potentially dangerous installation.

These Built-In Unvented Fireboxes have been tested and approved as Ventless Firebox Enclosures for Gas-Fired Decorative Type Ventless Room Heaters to IAS 2-97.

WARNING: THESE BUILT-IN UNVENTED FIREBOXES HAVE ONLY BEEN TESTED AND APPROVED FOR USE WITH ANSI Z21.11.2 UNVENTED GAS LOGS.

DO NOT ATTEMPT TO BURN SOLID WOOD FUELS, OTHER GAS LOG SETS OR ANY OTHER COMBUSTIBLE MATERIALS IN THIS UNVENTED FIREBOX.

Log Set Sizing Reference Chart

Unvented Firebox Model	Unvented Room Heater Log Set	
	Natural	Propane (L.P.G)
UVFC-500	VFGL-18/24MN/VN-3 PVFGL-18MN/VN	VFGL-18/24MP/VP-3 PVFGL-18MP/VP
UVFC-600	VFGL-24/28MN/VN-3 PVFGL-24MN/VN	VFGL-24/28MP/VP-3 PVFGL-24MP/VP
UVFR-500	VFGL-18/24MN/VN-3 PVFGL-18MN/VN	VFGL-18/24MP/VP-3 PVFGL-18MP/VP
UVFR-600	VFGL-24/28MN/VN-3 PVFGL-24MN/VN	VFGL-24/28MP/VP-3 PVFGL-24MP/VP

Check the inventory list to be sure that you have all the necessary parts in usable condition. Also check for concealed damage.

Inventory

- Unvented Gas Firebox
- Canopy
- Gas Connector Fittings
- Installation and Operating Instructions

Tools and Building Supplies Normally Required

Tools Should Include:

- Phillips screwdriver
- Hammer
- Saw and/or sabersaw
- Level
- Measuring tape
- Electric drill and bits
- Pliers
- Square
- Piping complying with local codes
- Pipe wrench
- Tee joint
- Pipe compound

Building Supplies Should Include:

- Framing materials
- Wall finishing materials
- Caulking materials (noncombustible)
- Fireplace surround materials (noncombustible)

IMPORTANT SAFETY INFORMATION

INSTALLER: PLEASE LEAVE THESE INSTRUCTIONS WITH THE OWNER.

OWNER: PLEASE RETAIN THESE INSTRUCTIONS FOR FUTURE REFERENCE

IMPORTANT: BEFORE STARTING YOUR FIREBOX INSTALLATION, READ THESE INSTALLATION INSTRUCTIONS CAREFULLY TO BE SURE YOU UNDERSTAND THEM COMPLETELY AND IN ENTIRETY. FAILURE TO FOLLOW THESE INSTRUCTIONS COULD CAUSE A HEATER MALFUNCTION RESULTING IN SERIOUS INJURY AND/OR PROPERTY DAMAGE.

WARNING: ANY CHANGE TO THIS UNVENTED ROOM HEATER CAN BE DANGEROUS. IMPROPER INSTALLATION OR USE OF THIS HEATER CAN CAUSE SERIOUS INJURY OR DEATH FROM FIRE, BURNS, EXPLOSION OR CARBON MONOXIDE POISONING.

Carbon Monoxide Poisoning: Early signs of carbon monoxide poisoning are similar to the flu with headaches, dizziness and/or nausea. If you have these signs, obtain fresh air immediately. Have the Unvented Gas Heater serviced as it may not be operating correctly.

- Due to high temperatures, the firebox should be located out of traffic and away from furniture and draperies.
- Children and adults should be alerted to the hazard of high surface temperature and should stay away to avoid burns or clothing ignition.
- Young children should be carefully supervised when they are in the same room with the heater.
- Do not place clothing or other flammable material on or near the heater.
- Any safety screen or guard removed for servicing the firebox must be replaced and/or closed prior to operating the heater.
- Installation and repair should be done by a qualified service person. The heater should be inspected before use and at least annually by a professional service person. More frequent cleaning may be required due to excessive lint from carpeting, bedding material, etc. It is important that control compartments, burners and circulating air passageways of the heater be kept clean.
- Allow the heater to cool before servicing. Always shut off any electricity or gas to the heater while performing service work.
- Do not install the firebox in a sleeping room or bathroom.
- The appliance and its individual shut-off valve must be disconnected from the gas supply piping system while performing any tests of the gas supply piping system at pressures in excess of 1/2 psig.
- The heater must be isolated from the gas supply piping system by closing its individual manual shut-off valve during any pressure testing of the gas supply piping system at test pressures equal to or less than 1/2 psig.
- Keep heater area clear and free from combustible materials, gasoline and other flammable vapors and liquids.
- Do not use this heater if any part has been under water. Immediately call a qualified service technician to inspect the heater and to replace any part of the control system and any gas control which has been under water.

- Ensure that the heater is clean when operating. Excessive dust accumulation on the burner and logs will increase the amount of carbon monoxide formation and could lead to carbon monoxide poisoning and death.

CODES

Adhere to all local codes or in their absence the latest edition of The National Fuel Gas Code ANSI Z223.1 or NFPA54 which can be obtained from The American National Standards Institute, Inc. (1430 Broadway, New York, NY, 10018) or National Fire Protection Association, Inc. (Batterymarch Park, Quincy, MA, 02269).

COMBUSTION AND VENTILATION AIR

Heaters installed in these appliances shall not be installed in a confined space. Heaters installed in these appliances may be located in unusually tight construction provided the space is unconfined, or if confined, is provided with two permanent openings communicating directly with an additional room(s) of sufficient volume so that the combined volume of all connected spaces meets the criteria for an unconfined space, (National Fuel Gas Code ANSI Z223.1 1992, Section 5.3). Generally 50 ft³ per 1,000 BTU input of all operating appliances in the space.

The National Fuel Gas Code defines a confined space as a space whose volume is less than 50 ft³ per 1,000 BTU/Hr (4.8 m³ per kw) of the aggregate input rating of all appliances installed in that space and an unconfined space as a space whose volume is not less than 50 ft³ per 1,000 BTU/Hr (4.8 m³ per kw) of the aggregate input rating of all appliances installed in that space. Rooms communicating directly with the space in which the appliances are installed, through openings not furnished with doors, are considered a part of the unconfined space.

Unusually tight construction is defined as construction where:

- wall and ceilings exposed to the outside atmosphere have a continuous water vapor retarder with a rating or one perm or less with openings gasketed or sealed, and
- weather stripping has been added on operable windows and doors, and
- caulking or sealants are applied to areas such as joints around window and door frames, between sole plates and floors, between wall-ceiling joints, between wall panels, at penetrations for plumbing, electrical, and gas lines, and at other openings.

Use the following equations to determine if you have a confined or unconfined space.

- Determine the volume of space — ft³.

$$\text{Length} \times \text{Width} \times \text{Height} = \text{_____} \text{ ft}^3$$

(Include adjoining rooms with doorless passageways or ventilation grills between rooms.)

Example: 24' (L) x 16' (W) x 8' (H) = 3072 ft³

- Divide the volume of space by 50 ft³ to determine the maximum BTU/Hr the space can support.

$$\text{_____} (\text{volume of space} - \text{ft}^3) / 50 \text{ ft}^3 = (\text{Maximum BTU/Hr the space can support})$$

Example: 3072 ft³ / 50 ft³ = 61.44 or 61,440 BTU/Hr the space can support.

- Add the BTU/Hr of all the fuel burning appliances in the space.

Vent-Free heater	_____	BTU/Hr
Gas appliance #1*	_____	BTU/Hr
Gas appliance #2	+ _____	BTU/Hr
Total = _____		BTU/Hr

Example:

Vent-free heater	26,000	BTU/Hr
Gas appliance #1 (water heater)	40,000	BTU/Hr
Total = 66,000		BTU/Hr

* Do not include direct-vent gas appliances. Direct-vent is sealed combustion and draws combustion air from the outdoors.

- Compare the maximum BTU/Hr the space can support with the actual amount of BTU/Hr used.

_____ BTU/Hr	
(max. the space can support)	
_____ BTU/Hr	
(actual amount of BTU/Hr used)	

Example:

61,440	BTU/Hr
	(max. the space can support)
66,000	BTU/Hr
	(actual amount of BTU/Hr used)

The space in the above example is a confined space because the actual BTU/Hr used is more than the maximum BTU/Hr the space can support. You must provide additional fresh air.

WARNING: IF THE AREA IN WHICH THE HEATER MAY BE OPERATED IS SMALLER THAN THAT DEFINED AS AN UNCONFINED SPACE, PROVIDE ADEQUATE COMBUSTION AND VENTILATION AIR BY ONE OF THE METHODS DESCRIBED IN THE NATIONAL FUEL GAS CODE, ANSI Z223.1 1992, SECTION 5.3 OR APPLICABLE LOCAL CODES.

Your options are:

- Rework equations adding the space of adjoining room(s). If the extra volume provides an unconfined space, then remove door or add ventilation grills between rooms. Refer to National Fuel Gas Code, ANSI Z223.1 1992, Section 5.3.
- Vent room directly to the outdoors. Refer to National Fuel Gas Code, ANSI Z223.1 1992, Section 5.3.
- Install a lower BTU/Hr heater, such as a 21,000 BTU/Hr, to make the area an unconfined space.

If the actual BTU/Hr used is less than the maximum BTU/Hr the space can support, then the space is an unconfined space. You will need no additional fresh air ventilation for an unconfined space.

LOCATION OF FIREBOX

Carefully select the best location for installation of your built-in unvented firebox. The following factors should be taken into consideration:

- Clearance to side wall, ceiling, woodwork and windows.
- Location must not be affected by drafts caused by kitchen exhaust fans, return air registers for forced air furnaces/air conditioners, windows or doors.
- Installation must provide adequate ventilation and combustion air.
- Do not install this firebox in a sleeping room or bathroom.
- Location should be out of high traffic areas and away from furniture and draperies due to heat from firebox.

- Never obstruct the front opening of the unvented firebox or restrict the flow of combustion and ventilation air.

- Minimize modifications to existing construction. See *Figure 1* for location suggestions.

WARNING: MAINTAIN MINIMUM CLEARANCES.

Do not install in the vicinity where gasoline or other flammable liquids may be stored. The unvented firebox must be kept clear and free from these combustible materials.

CAUTION: HEATERS CREATE WARM AIR CURRENTS. THESE CURRENTS MOVE HEAT TO WALL SURFACES NEXT TO HEATER. INSTALLING HEATER NEXT TO VINYL OR CLOTH WALL COVERINGS OR OPERATING HEATER WHERE IMPURITIES IN THE AIR (SUCH AS TOBACCO SMOKE) EXISTS, MAY DISCOLOR WALLS.

WARNING: DO NOT ALLOW FANS TO BLOW DIRECTLY INTO THE FIREPLACE. AVOID ANY DRAFTS THAT ALTER BURNER FLAME PATTERNS.

WARNING: DO NOT USE A BLOWER INSERT, HEAT EXCHANGER INSERT OR OTHER ACCESSORY NOT APPROVED FOR USE WITH THIS FIREPLACE.

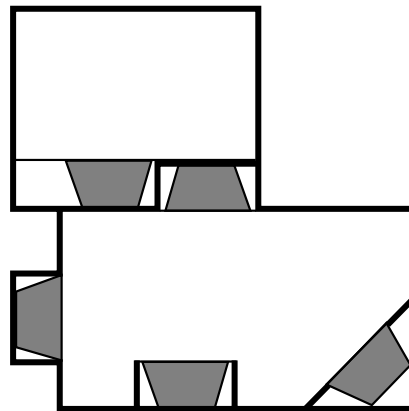

Not to Scale

Figure 1

Clearances

WARNING: DO NOT INSTALL THESE BUILT-IN UNVENTED FIREBOXES IN SLEEPING QUARTERS, OR IN RECREATIONAL VEHICLES.

WARNING: DO NOT INSTALL THESE APPLIANCES:

- WHERE CURTAINS, FURNITURE, CLOTHING OR OTHER FLAMMABLE OBJECTS ARE LESS THAN 42" FROM THE FRONT OF THE UNVENTED ROOM HEATER.
- IN HIGH TRAFFIC AREAS.
- IN WINDY OR DRAFTY AREAS.

Ensure the minimum clearances shown in *Figures 2 and 3* are maintained. Left and right clearances are determined when facing the front of the firebox.

Follow these instructions carefully to ensure safe installation. Failure to follow these requirements may create a fire hazard.

Sidewall clearances: The sides of the firebox opening must be at least 16" from any combustible wall (*Figure 2*).

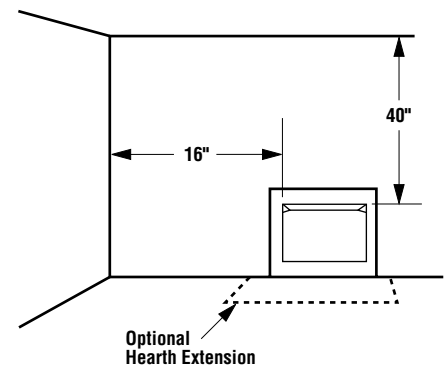

Figure 2

Ceiling clearance: The ceiling must be at least 40" from the top of the firebox opening (*Figure 2*).

Noncombustible material: Noncombustible materials, such as slate and marble, must be at least 1/2" thick and may be used without restriction above the firebox opening, to the sides or as a hearth extension, so long as they do not obstruct vent openings for heat circulating models.

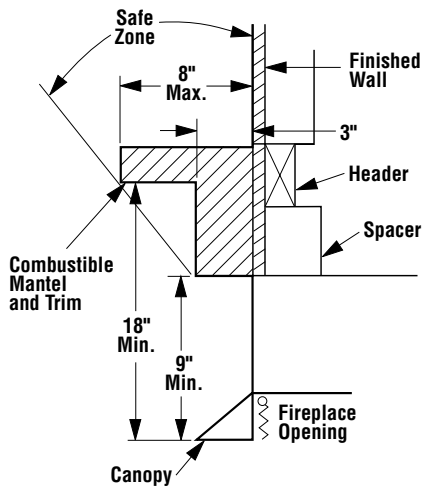

Figure 3

Noncombustible material (minimum requirements) with wood mantel or other combustible projections: To install the firebox with a wood mantel, shelf or other combustible projection above firebox opening. Refer to Figure 3.

WARNING: THE CANOPY HOOD MUST BE IN PLACE TO BE IN COMPLIANCE WITH THE CLEARANCES SPECIFIED IN FIGURE 3. DO NOT REMOVE OR REPLACE CANOPY, ONLY USE CANOPY SUPPLIED WITH THE FIREBOX. DO NOT USE ANY CANOPY WHICH MAY BE PROVIDED WITH THE DECORATIVE TYPE UNVENTED ROOM HEATER.

If your mantel profile is unsafe, you may either:

- Raise the mantel to an acceptable height, or
- Remove the mantel.

Floor clearance: These fireplaces may sit directly on a combustible surface.

ASSEMBLY STEPS

Note: Illustrations shown in this manual reflect "typical" installations with nominal dimensions and are for design and framing reference only. Actual installations may vary due to individual design preferences. However, always maintain minimum clearances to combustible materials and do not violate any specific installation requirements. Refer to the Framing Specifications Figures on page 8.

Note: The following steps represent the normal sequence of installation. Each installation is unique, however, and might require a different sequence.

Step 1. Position firebox prior to framing or into prepared framing.

Step 2. Field wire main power supply to circulating models for fan kit. (Electrical connections should only be performed by an experienced, licensed/certified tradesman.)

Step 3. Plumb gas line. (Gas connections should only be performed by an experienced, licensed/certified tradesman.)

Step 4. Install decorative type unvented room heater per the instructions provided with the unvented room heater.

Step 5. Complete finish wall material, surround and optional hearth extension to your individual taste.

INSTALLATION

Gas Line Installation

CAUTION: PLUMBING CONNECTIONS SHOULD ONLY BE PERFORMED BY A QUALIFIED, LICENSED PLUMBER. MAIN GAS SUPPLY MUST BE OFF WHEN PLUMBING GAS LINE TO FIREPLACE OR PERFORMING SERVICE.

Consult all local codes.

It is recommended that the 1/2" gas line enter the side of the firebox. Connect the gas line before the firebox is enclosed in the finished wall. The gas knockout is determined by an indentation located at the bottom and slightly off center in the side refractories. **THE KNOCK-OUT IS ALWAYS REMOVED FROM INSIDE THE FIREBOX.** If removal is attempted from the outer wrapper, side-refractory damage may occur. With a medium-sized hammer, lightly tap the surface of the indentation. The refractory material is very thin in this area and is easily removed. Once a small hole has been made, continue tapping until you have reached sufficient diameter for the gas line to fit through. The entire knockout does not have to be removed.

Install only a 1/2" (1 1/2" max.) inside diameter approved gas line through the firebox wall for connection to the unvented room heater inside the firebox.

Ensure that a sediment trap is installed in the existing gas line, if not, install a sediment trap upstream of the heater to prevent moisture and contaminants from passing through trap to the heater controls and burners. Failure to do so could prevent the heater from operating reliably.

An external regulator must be used on all propane (L.P.G.) heaters, in addition to the regulator fitted to the heater, to reduce the supply tank pressure to 13" w.c. (maximum). Any copper tubing used to supply propane (L.P.G.) from the tank must be internally tinned.

IMPORTANT: HOLD HEATER REGULATOR WITH A WRENCH TO PREVENT MOVEMENT WHEN CONNECTING TO INLET PIPING.

Check Gas Type: The gas supply must be the same as stated on the heater's rating plate. If the gas supply is different, **DO NOT INSTALL** the heater. Contact your dealer for the correct model.

WARNING: CONNECTING DIRECTLY TO AN UNREGULATED PROPANE (L.P.G.) TANK CAN CAUSE AN EXPLOSION.

IMPORTANT: RE-PACK INSULATION MATERIAL IN SQUARE HOLE AROUND GAS LINE, INTERIOR AND EXTERIOR, TO SEAL.

Consult installation and operating instructions for the model of unvented room heater to be installed.

Checking Gas Connections: Test all gas joints from the gas meter to the gas heater regulator for leaks using soap and water solution after completing connection. **DO NOT USE AN OPEN FLAME.**

Firebox Framing

Construct firebox framing following *Figures 6 through 8* and the chart on page 8 for your specific installation requirements. Refer to *Figures 4 and 5* on pages 6 and 7 for firebox dimensions.

The firebox may be installed directly on a combustible floor or raised on a platform of an appropriate height. Do not place firebox on carpeting, vinyl or other soft floor coverings. It may, however, be placed on flat wood, plywood, particle board, metal or other hard surfaces which extend the full width and depth of the enclosure. Be sure firebox rests on a solid continuous floor or platform with appropriate framing for support and so that no cold air can enter room from under the firebox.

The firebox may be positioned and then the framing built around it, or the framing may be constructed and the firebox positioned into the opening.

Usually, no special floor support is needed for the firebox, however, to be certain:

1. Estimate the total weight of the firebox system and surround materials such as marble, brick, stone, etc., to be installed.
2. Measure the square footage of the floor space to be occupied by the system and surrounds.
3. Note the floor construction, i.e. 2 x 6's, 2 x 8's or 2 x 10's, single or double joists, type and thickness of floor boards.
4. Use this information and consult your local building code to determine if you need additional support.

CAUTION: DO NOT BLOCK THE HEAT-CIRCULATING AIR INLETS AND OUTLETS ON THE VFC AND VFCE MODELS. DOING SO MAY CREATE A POTENTIAL FIRE HAZARD.

If you plan to raise the firebox, build the platform assembly then position firebox on top. Secure the platform to the floor to prevent possible shifting.

UVF-500 SPECIFICATIONS

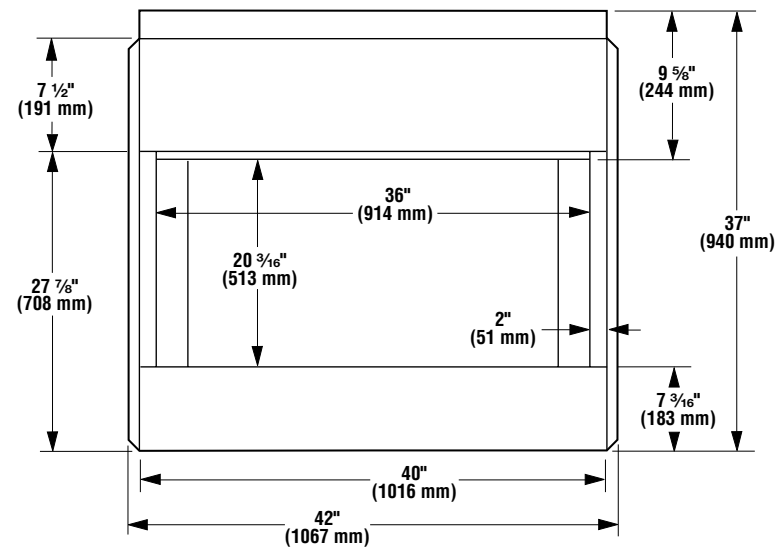

Front

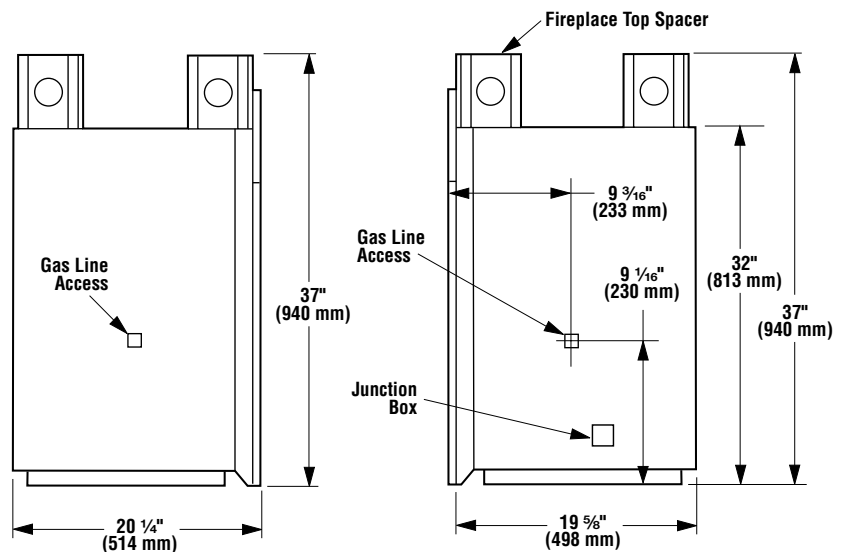

Left Side

Right Side

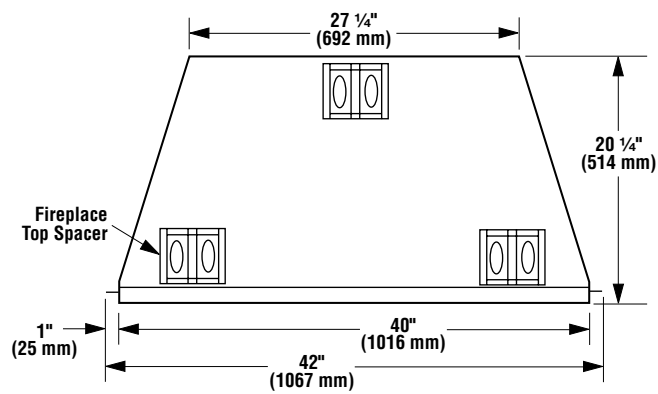

Top View

Figure 4

NOTE: DIAGRAMS & ILLUSTRATION NOT TO SCALE.

Firebox Installation

Note: The firebox must be installed giving full consideration to the clearance and height requirements identified in this manual.

Step 1. Slide the firebox into prepared framing or position firebox in its final position and frame later.

Step 2. Refer to firebox and framing specifications on pages 6, 7 and 8 *Figures 6 through 10* for framing dimensions and details. Framing header may be positioned directly on the firebox top spacers.

Note: The framed depth from a framed wall, must always be measured from a finished surface. If a wall covering such as drywall is to be attached to the rear wall, then the depth must be measured from the drywall surface. It is important that this dimension be exact.

IMPORTANT: UNDER NO CIRCUMSTANCES SHALL THE FIREBOX TOP SPACERS BE REMOVED OR MODIFIED. THE HEADER MAY BE IN DIRECT CONTACT WITH THE TOP SPACERS BUT MUST NOT BE SUPPORTED BY THEM OR NOTCHED TO FIT AROUND THEM.

Step 3. Level the firebox by checking the top edge of the firebox. Shim if necessary.

Step 4. Fireplace should be secured to side framing members using the full length nailing tabs at the top and bottom of the fireplace front face. Use 8d nails (*see Figure 9*).

UVF-600 SPECIFICATIONS

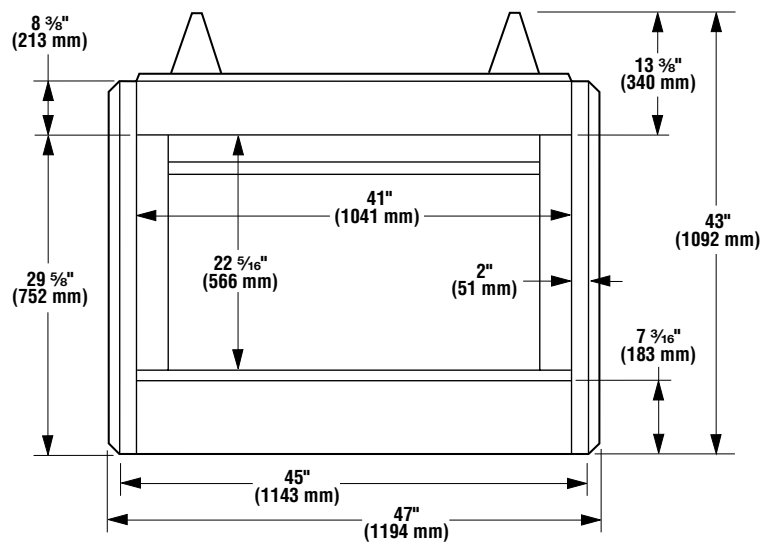

Front

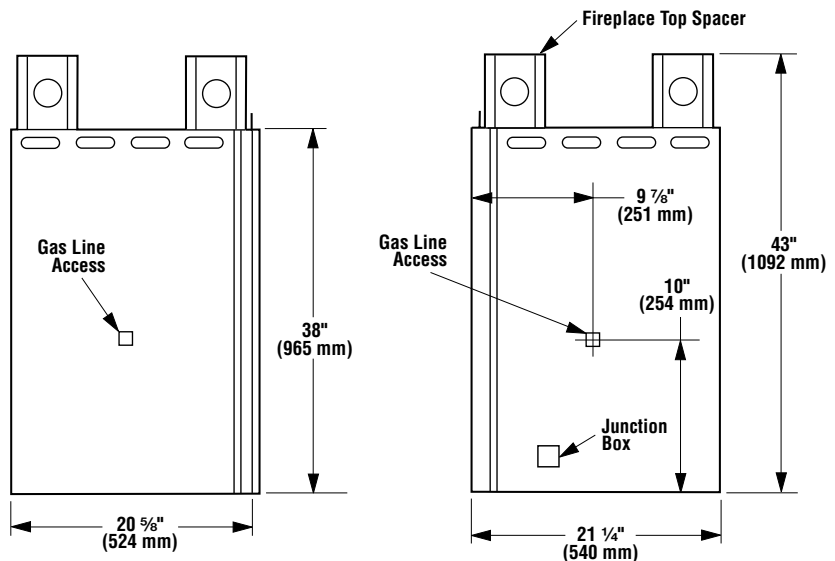

Left Side

Right Side

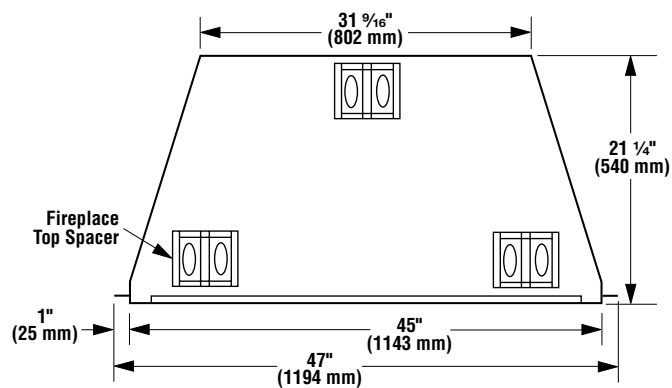

Top View

Figure 5

NOTE: DIAGRAMS & ILLUSTRATION NOT TO SCALE.

FRAMING SPECIFICATIONS

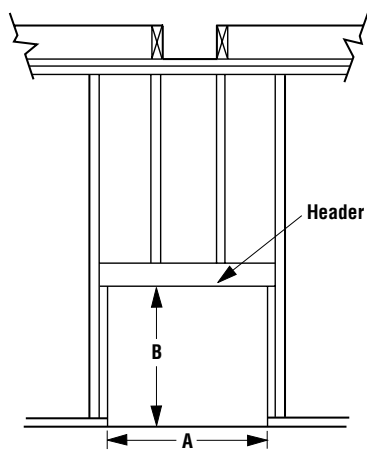

Figure 6

Framing Dimensions

Opening	UVF-500	UVF-600
A	41 1/4"	46 1/4"
B	37 1/2"	43 1/2"
C	27 1/2"	31 3/4"
D	13 3/4"	15 7/8"
E	66 3/4"	73"
F	33 3/8"	36 1/2"
G	19 5/8"	20 5/8"
H	47 1/4"	51 5/8"

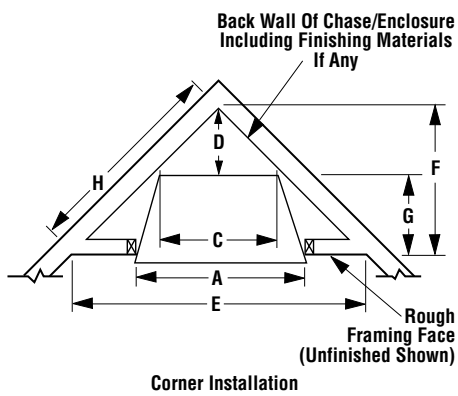

Figure 7

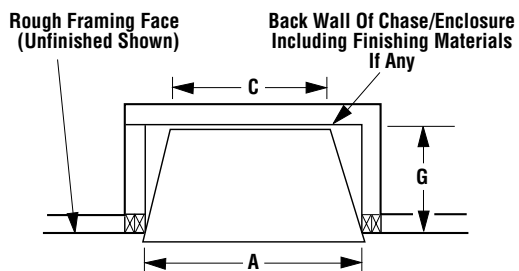

Figure 8

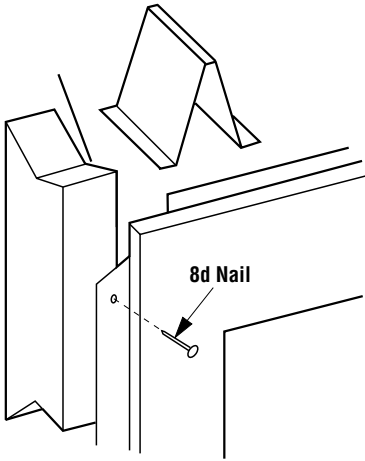

Figure 9

Note: The nailing flange and the area directly behind the nailing flange is exempt from the clearances described on the firebox clearance label.

Step 5. To safely operate the heater with consideration of the mantel clearances the canopy must be installed.

Canopy Installation

The factory-supplied canopy must be installed on the firebox for safe operation. See *Figure 10*.

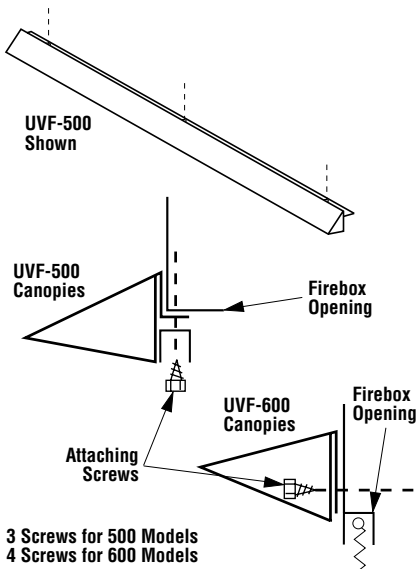

Figure 10

Step 1. Remove the screws from the top front frame assembly. There are three (3) screws on the 500 models and four (4) screws on the 600 models.

Step 2. Align the canopy with the holes in the top frame.

Step 3. Replace the screws previously removed.

Step 4. Tighten side screws. Make sure the canopy is level and secure.

OPTIONAL EQUIPMENT

Blower Kit Circulating Models Only

If you are installing one of the blower kits, Models FBK-100 or FBK 200, follow Steps 1 through 5, and see the installation instructions provided with the kit for electrical wiring requirements (see *Figure 11*). The firebox must be connected to main power supply at time of installation if a forced air kit is to be installed later. The electrical connections must be made before the firebox is framed and enclosed in the finished walls.

This appliance must be electrically grounded in accordance with local codes or, in the absence of local codes, the national electrical code, ANSI/NFPA 70 - (Latest Edition).

CAUTION: ELECTRICAL CONNECTIONS SHOULD ONLY BE PERFORMED BY A QUALIFIED, LICENSED ELECTRICIAN. MAIN POWER MUST BE OFF WHEN CONNECTING TO MAIN ELECTRICAL POWER SUPPLY OR PERFORMING SERVICE.

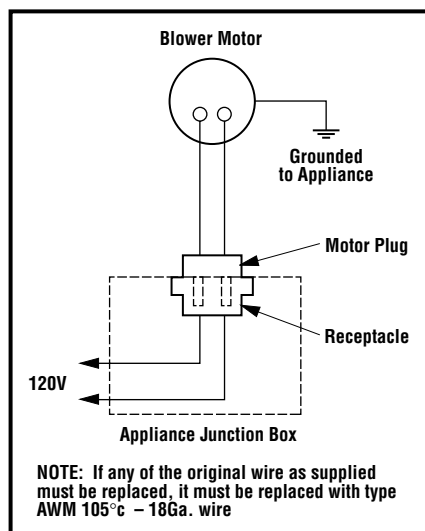

Figure 11

Blower Kit Installation

To install the blower kit, follow Steps 1 thru 5 and refer to *Figures 12, 13 and 14*.

Step 1. Locate the blower motor shield.

Step 2. Remove the motor shield by bending it along the perforation until the tabs break away.

Step 3. With the motor shield removed, place the blower in the unit with the power cord up and slide to the back of the unit until the motor is behind the rear support.

Step 4. Rotate the blower 90 degrees, so that the discharge is up.

Step 5. Move left side of blower around until it is in the proper position and bend the retaining tabs in the bottom of the unit up into the slots on the blower.

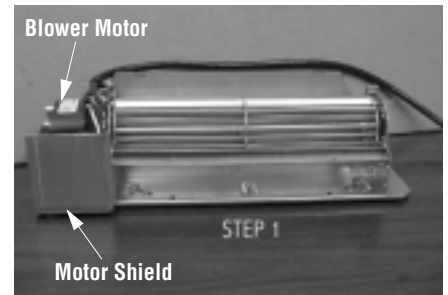

Figure 12

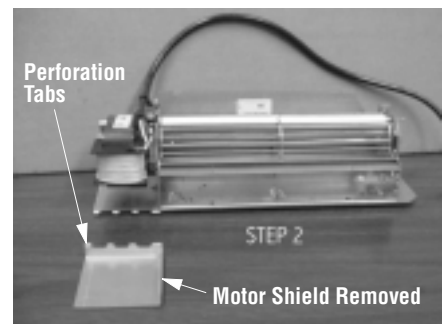

Figure 13



Figure 14

NOTE: DIAGRAMS & ILLUSTRATION NOT TO SCALE.

FIREBOX FINISHES

There are a wide variety of "finished looks" for your built-in unvented firebox from formal wall decor with elaborate mantels to rustic wood paneling or warm brick facings.

Only noncombustible materials like marble, stone, tile, brick, etc. may overlap the black front facing but be sure not to block the upper or lower grilles. Seal all joints between the black facing and wall surrounds to prevent air intrusion. Use noncombustible caulking material only to seal the black metal facing to the surround material on the finished wall.

REPLACEMENT PARTS

An exploded view of the firebox with numbered parts and a replacement parts list can be found on page 11. Normally, all parts should be ordered through your distributor or dealer. Parts will be shipped at prevailing prices at time of order.

When ordering repair parts, always give the following information:

1. The model number of the firebox.
2. The serial number of the firebox.
3. The part number.
4. The description of the part.
5. The quantity required.
6. The installation date of the firebox.

If you encounter any problems or have any questions concerning the installation of a unvented heater in this system, please contact your distributor or dealer.

ACCESSORIES AND COMPONENTS

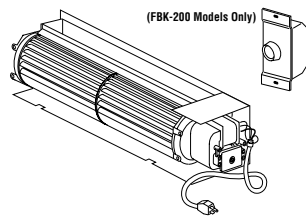

Blower Kits		
-Single Speed	80L84	FBK-100
-Variable Speed	80L85	FBK-200

Blower Kit

The FBK-100 blower provides for a constant velocity forced air circulation feature for your appliance. The FBK-200 assembly with variable speed wall switch provides a forced air circulation feature for your appliance.

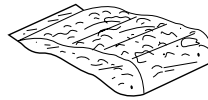

Decorative Volcanic Stone	80L42	FDVS
----------------------------------	-------	------

Decorative Volcanic Stone

The decorative volcanic stone, Model FDVS, can be used to enhance the look of your appliance. Decorative volcanic stone is standard with this appliance. Order model FDVS for replacement of stone when needed. Spread the decorative volcanic stone evenly around the bottom of the firebox.

NOTE: DIAGRAMS & ILLUSTRATION NOT TO SCALE.

REPLACEMENT PARTS

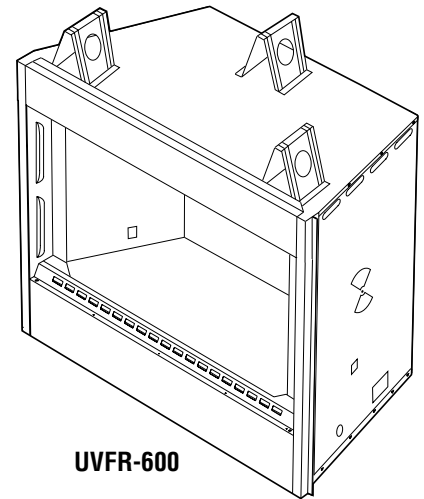
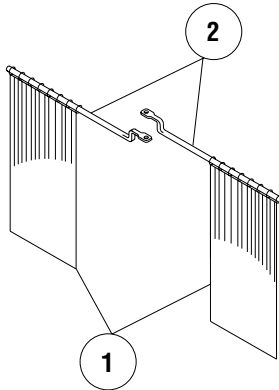
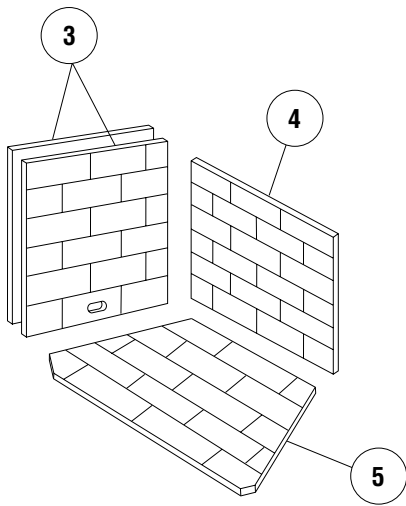

UVFR-600

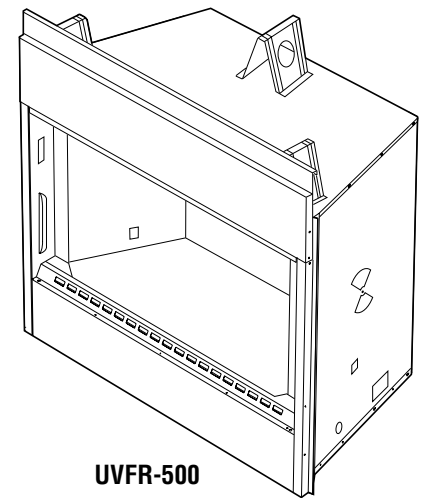
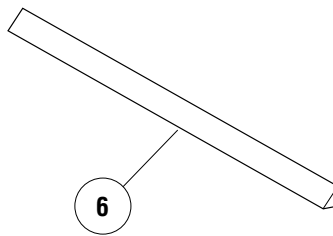
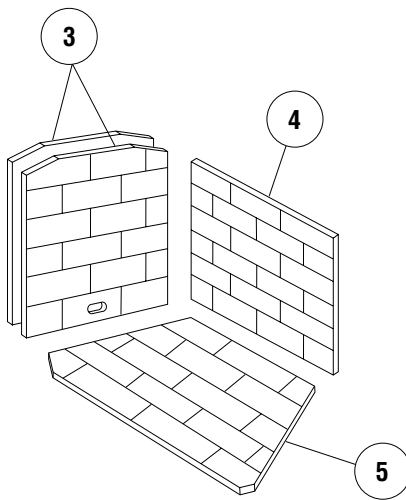

UVFR-500

No.	DESCRIPTION	UVF-500		UVF-600	
		Part No.	Qty.	Part No.	Qty.
	Gas Fireplace Assembly	—	—	—	—
1.	Firescreen	36L89	2	36L99	2
2.	Rod, Screen	88L95	2	88L96	2
3.	Refractory, Side	88L59	2	88L65	2
4.	Refractory, Rear	88L58	1	88L64	1
5.	Refractory Base	88L57	1	88L63	1
6.	Canopy	96L27	1	96L28	1

NOTE: DIAGRAMS & ILLUSTRATION NOT TO SCALE.

The manufacturer reserves the right to make changes at any time, without notice, in design, materials, specifications, prices and also to discontinue colors, styles and products.
Consult your local distributor for fireplace code information.

Printed in U.S.A. © 2000 by LHP
P/N 700,018M REV. C 12/2003

Manufactured By LHP
1110 West Taft Avenue • Orange, CA 92865

Free Manuals Download Website

<http://myh66.com>

<http://usermanuals.us>

<http://www.somanuals.com>

<http://www.4manuals.cc>

<http://www.manual-lib.com>

<http://www.404manual.com>

<http://www.luxmanual.com>

<http://aubethermostatmanual.com>

Golf course search by state

<http://golfingnear.com>

Email search by domain

<http://emailbydomain.com>

Auto manuals search

<http://auto.somanuals.com>

TV manuals search

<http://tv.somanuals.com>