



Sun Fire™ V100 Server User's Guide

Sun Microsystems, Inc.
901 San Antonio Road
Palo Alto, CA 94303
U.S.A. 650-960-1300

Part No.816-2756-10
Revision A December 2001

Send comments about this document to: docfeedback@sun.com

Copyright 2001 Sun Microsystems, Inc., 901 San Antonio Road, Palo Alto, CA 94303-4900 U.S.A. All rights reserved.

This product or document is distributed under licenses restricting its use, copying, distribution, and decompilation. No part of this product or document may be reproduced in any form by any means without prior written authorization of Sun and its licensors, if any. Third-party software, including font technology, is copyrighted and licensed from Sun suppliers.

Parts of the product may be derived from Berkeley BSD systems, licensed from the University of California. UNIX is a registered trademark in the U.S. and other countries, exclusively licensed through X/Open Company, Ltd.

Sun, Sun Microsystems, the Sun logo, AnswerBook2, docs.sun.com, UltraSPARC™-Ile, OpenBoot™ PROM, SunSolve, Solaris, and Netra are trademarks, registered trademarks, or service marks of Sun Microsystems, Inc. in the U.S. and other countries. All SPARC trademarks are used under license and are trademarks or registered trademarks of SPARC International, Inc. in the U.S. and other countries. Products bearing SPARC trademarks are based upon an architecture developed by Sun Microsystems, Inc.

The OPEN LOOK and Sun™ Graphical User Interface was developed by Sun Microsystems, Inc. for its users and licensees. Sun acknowledges the pioneering efforts of Xerox in researching and developing the concept of visual or graphical user interfaces for the computer industry. Sun holds a non-exclusive license from Xerox to the Xerox Graphical User Interface, which license also covers Sun's licensees who implement OPEN LOOK GUIs and otherwise comply with Sun's written license agreements.

Federal Acquisitions: Commercial Software—Government Users Subject to Standard License Terms and Conditions.

DOCUMENTATION IS PROVIDED "AS IS" AND ALL EXPRESS OR IMPLIED CONDITIONS, REPRESENTATIONS AND WARRANTIES, INCLUDING ANY IMPLIED WARRANTY OF MERCHANTABILITY, FITNESS FOR A PARTICULAR PURPOSE OR NON-INFRINGEMENT, ARE DISCLAIMED, EXCEPT TO THE EXTENT THAT SUCH DISCLAIMERS ARE HELD TO BE LEGALLY INVALID.

Copyright 2001 Sun Microsystems, Inc., 901 San Antonio Road, Palo Alto, CA 94303-4900 Etats-Unis. Tous droits réservés.

Ce produit ou document est distribué avec des licences qui en restreignent l'utilisation, la copie, la distribution, et la décompilation. Aucune partie de ce produit ou document ne peut être reproduite sous aucune forme, par quelque moyen que ce soit, sans l'autorisation préalable et écrite de Sun et de ses bailleurs de licence, s'il y en a. Le logiciel détenu par des tiers, et qui comprend la technologie relative aux polices de caractères, est protégé par un copyright et licencié par des fournisseurs de Sun.

Des parties de ce produit pourront être dérivées des systèmes Berkeley BSD licenciés par l'Université de Californie. UNIX est une marque déposée aux Etats-Unis et dans d'autres pays et licenciée exclusivement par X/Open Company, Ltd.

Sun, Sun Microsystems, le logo Sun, AnswerBook2, docs.sun.com, UltraSPARC™-Ile, OpenBoot™ PROM, Solaris et Netra sont des marques de fabrique ou des marques déposées, ou marques de service, de Sun Microsystems, Inc. aux Etats-Unis et dans d'autres pays. Toutes les marques SPARC sont utilisées sous licence et sont des marques de fabrique ou des marques déposées de SPARC International, Inc. aux Etats-Unis et dans d'autres pays. Les produits portant les marques SPARC sont basés sur une architecture développée par Sun Microsystems, Inc.

L'interface d'utilisation graphique OPEN LOOK et Sun™ a été développée par Sun Microsystems, Inc. pour ses utilisateurs et licenciés. Sun reconnaît les efforts de pionniers de Xerox pour la recherche et le développement du concept des interfaces d'utilisation visuelle ou graphique pour l'industrie de l'informatique. Sun détient une licence non exclusive de Xerox sur l'interface d'utilisation graphique Xerox, cette licence couvrant également les licenciés de Sun qui mettent en place l'interface d'utilisation graphique OPEN LOOK et qui en outre se conforment aux licences écrites de Sun.

LA DOCUMENTATION EST FOURNIE "EN L'ETAT" ET TOUTES AUTRES CONDITIONS, DECLARATIONS ET GARANTIES EXPRESSES OU TACITES SONT FORMELLEMENT EXCLUES, DANS LA MESURE AUTORISEE PAR LA LOI APPLICABLE, Y COMPRIS NOTAMMENT TOUTE GARANTIE IMPLICITE RELATIVE A LA QUALITE MARCHANDE, A L'APTITUDE A UNE UTILISATION PARTICULIERE OU A L'ABSENCE DE CONTREFAÇON.



Contents

- 1. Introducing the Sun Fire V100 Server 1**
 - Overview of the Sun Fire V100 Server 2
 - Contents of the Ship Kit 3
 - Preinstalled Software 3
 - Optional Components 4
 - Installation Quick Start 5

- 2. Installing the Sun Fire V100 Server Into a Rack 7**
 - Choosing Between a Rack and a Cabinet 8
 - Installing the Sun Fire V100 Server Into a
19-Inch Wide or 72-inch Tall Four-Post Rack 8
 - The 19-Inch Rackmounting Kit 8
 - Tips for Using a Sun StorEdge 72-inch Rack 16
 - Connecting the Cables 17

- 3. Communicating With the Server 19**
 - Setting Up a Console Connection to the Server 20
 - Which Is the Appropriate Serial Port? 20
 - Serial Port Pin Arrangement 20
 - Serial Connection Settings 21
 - Serial Adapters 22

| | |
|---|-----------|
| Connecting to the Server Using a Sun Workstation or ASCII Terminal | 23 |
| Connecting to the Server Using a Terminal Server | 25 |
| Connecting to a Cisco Terminal Server | 25 |
| Connecting to Other Terminal Servers | 26 |
| Connecting to the Server Using a System Running Microsoft Windows | 27 |
| Connecting to the Server Using a Handheld Device | 29 |
| Using the Arrow Keys | 31 |
| 4. Powering On and Configuring the Sun Fire V100 Server | 33 |
| Powering On and Configuring the Server | 34 |
| Using the Power (On/Standby) Switch | 39 |
| 5. Managing the Sun Fire V100 Server From the lom> Prompt | 43 |
| Introduction to Lights-Out Management | 43 |
| Using LOM Commands | 44 |
| Powering On or Resetting the Server From the LOM Shell | 45 |
| Controlling the Server's Booting Behavior | 47 |
| Monitoring the Server From the LOM Shell | 49 |
| Viewing the LOM Event Log | 51 |
| Verifying That a Component Has Been Fixed | 53 |
| Setting Up LOM Privileges for Named Users | 54 |
| Permissions Available for LOM Users | 54 |
| Setting the LOM Configurable Variables | 58 |
| Separating LOM From the Console on the Serial A/LOM Port | 60 |
| Viewing Event Reports That LOM Sends to syslogd | 61 |
| LOM Shell Command List | 62 |
| 6. Managing the Sun Fire V100 Server From the Solaris Prompt | 65 |
| Monitoring the System From the Solaris Prompt | 66 |

| | |
|---|-----------|
| Checking the Supply Rail Voltages and Internal Circuit Breakers (lom -v) | 67 |
| Configuring Automatic Server Restart | 73 |
| Enabling the LOM Watchdog Process From Your Own Script or Command (lom -W on) | 74 |
| Other LOM Tasks You Can Perform From the Solaris Prompt | 76 |
| 7. Interpreting the LEDs | 81 |
| Interpreting the Front- and Back-Panel LEDs | 82 |
| Front-Panel LEDs | 82 |
| Back-Panel LEDs | 83 |
| 8. Removing and Replacing Components | 85 |
| Adding Components or Replacing A Server | 86 |
| Replacing the System Configuration Card | 86 |
| Adding or Changing Internal Components | 87 |
| Memory Installation and Removal | 91 |
| Installing and Removing the Hard Disk Drive | 92 |
| 9. Reinstalling the Solaris Operating Environment | 97 |
| Reinstalling the Solaris Operating Environment | 98 |
| Reinstalling the Lights-Out Management Software | 98 |
| 10. Troubleshooting | 99 |
| Diagnostic Tools | 100 |
| POST Diagnostics | 100 |
| OpenBoot Diagnostics | 101 |
| SunVTS | 103 |
| Problems You Might Encounter | 105 |
| Power On Failure | 105 |
| Cannot Set Up a Console Connection to a Server | 105 |

| | |
|---|-----|
| No LOM Messages Displayed at the Terminal | 105 |
| Cannot Display the <code>lom></code> Prompt Using the #. Escape Sequence | 106 |
| Problems Connecting to the Server Using a Handheld Device | 106 |
| OpenBoot PROM Initialization Aborts and the Server Will Not Boot | 106 |
| IDE Controller Failure | 107 |
| Jumper Settings | 107 |
| Frequently Asked Questions | 108 |
| Acoustic Noise Generated | 116 |
| Environmental Compliance Information | 117 |

Figures

- FIGURE 1-1 The Sun Fire V100 server 2
- FIGURE 2-1 Cable Management Bracket 9
- FIGURE 2-2 Positioning the Slide Mounts for a Sun StorEdge 72-Inch Tall Rack 10
- FIGURE 2-3 Positioning the Slide Mounts for a Standard 19-Inch Wide Rack 10
- FIGURE 2-4 Fastening the Slide Mounts to a Sun StorEdge 72-inch Tall Rack – Rear View (Side Panels Removed for Clarity) 11
- FIGURE 2-5 Fastening the Slide Mounts to a Sun StorEdge 72-inch Expansion Rack – Front View (Side Panels Removed for Clarity) 12
- FIGURE 2-6 Fastening the Slide Mounts to a Standard 19-inch Rack 13
- FIGURE 2-7 Sliding the Sun Fire V100 Server Into a Standard 19-Inch Rack 14
- FIGURE 2-8 Adjusting the Slide Mounts and Screwing the Server Into the Rack 15
- FIGURE 2-9 Fitting the Cable Management Bracket to a Sun StorEdge or a Standard 19-Inch Rack 16
- FIGURE 2-10 The Server's Back Panel 17
- FIGURE 3-1 Serial Port Pins 1 to 8 21
- FIGURE 4-1 Sun Fire V100 Server Power (On/Standby) Switch 39
- FIGURE 6-1 Sample LOM Device Event Log (Oldest Event Reported First) 73
- FIGURE 7-1 Front-Panel Power and Fault LEDs 82
- FIGURE 7-2 Back-Panel Power and Fault LEDs 84
- FIGURE 8-1 The System Configuration Card Slot 87
- FIGURE 8-2 Using the Disposable Antistatic Wrist Strap Supplied With the System 88

| | | |
|-------------|---|-----|
| FIGURE 8-3 | Removing the Top Cover | 89 |
| FIGURE 8-4 | Replacing the Top Cover | 90 |
| FIGURE 8-5 | DIMM Insertion and Removal Sequence | 91 |
| FIGURE 8-6 | Installing Memory Into a Socket on the System Board | 92 |
| FIGURE 8-7 | Removing the HDD Placeholder | 93 |
| FIGURE 8-8 | Installing a Hard Disk Drive | 94 |
| FIGURE 10-1 | The <code>obdiag</code> Menu | 101 |

Tables

| | | |
|------------|--|-----|
| TABLE 1-1 | Contents of the Ship Kit | 3 |
| TABLE 1-2 | Customer Installable Hardware | 4 |
| TABLE 2-1 | 19-inch Rackmounting Kit | 8 |
| TABLE 3-1 | Server Serial Ports | 20 |
| TABLE 3-2 | Settings for Connecting to the Serial A/LOM or Serial B Port | 21 |
| TABLE 3-3 | Serial Adapters | 22 |
| TABLE 3-4 | Pin Crossovers in the Sun DB-25 (25-Pin) Adapter | 22 |
| TABLE 3-5 | Pin Crossovers in the DB-9 (9-Pin) Adapter | 23 |
| TABLE 3-6 | Pin Crossovers for Connecting to a Typical Terminal Server | 26 |
| TABLE 3-7 | Example PalmOS Terminal Emulator Macros | 32 |
| TABLE 5-1 | Boot Modes | 48 |
| TABLE 5-2 | LOM Commands | 62 |
| TABLE 10-1 | Open Boot Diagnostics Tests | 102 |
| TABLE 10-2 | SunVTS Tests | 103 |

Preface

The *Sun Fire™ V100 Server User's Guide* describes how to install, manage, and maintain the Sun Fire V100 server. The manual is intended for system administrators who have experience in setting up networked Solaris™ servers.

How This Book Is Organized

Part I Installation and Configuration

Chapter 1 introduces the Sun Fire V100 server, gives an overview of its specifications, lists the optional components available and includes an installation quick start guide.

Chapter 2 provides information about installing the Sun Fire V100 server into a rack and describes how to connect the cables.

Chapter 3 provides instructions on setting up console connections to the server via its serial A/LOM port.

Chapter 4 explains how to perform the initial power-on and configuration of the server.

Part II Remote and Local Management

Chapter 5 explains how to use the LOM shell.

Chapter 6 describes how to use LOM-specific Solaris commands to monitor and manage the system. This chapter also explains how to configure LOM to restart the server in the event of a system lockup.

Part III Maintenance and Troubleshooting

Chapter 7 provides information about the fault and power indicators and explains how to identify a faulty system in a rack.

Chapter 8 describes how to swap system configuration cards and how to open the Sun Fire V100 server to add memory or a hard disk drive.

Chapter 9 describes how to reinstall the Solaris operating environment.

Chapter 10 describes the diagnostic tools that are available, and provides troubleshooting and frequently asked questions sections.

Part IV Appendixes

Appendix A lists all physical and environmental specifications, and provides information on calculating power consumption and heat dissipation.

Appendix B describes the parameters you can configure in the LOM driver configuration file.

Using UNIX Commands

This document may not contain information about basic UNIX[®] commands and procedures such as shutting down the system, booting the system, and configuring devices.

See one or more of the following for this information:

- *Solaris Handbook for Sun Peripherals*
- AnswerBook2[™] online documentation for the Solaris software environment
- Other software documentation that you received with your system

Typographic Conventions

| Typeface | Meaning | Examples |
|------------------|--|---|
| AaBbCc123 | The names of commands, files, and directories; on-screen computer output | Edit your <code>.login</code> file. Use <code>ls -a</code> to list all files. % You have mail. |
| AaBbCc123 | What you type, when contrasted with on-screen computer output | % su Password: |
| <i>AaBbCc123</i> | Book titles, new words or terms, words to be emphasized | Read Chapter 6 in the <i>User's Guide</i> . These are called <i>class</i> options. You <i>must</i> be superuser to do this. |
| | Command-line variable; replace with a real name or value | To delete a file, type <code>rm filename</code> . |

Shell Prompts

| Shell | Prompt |
|---------------------------------------|-----------------------|
| C shell | <i>machine_name</i> % |
| C shell superuser | <i>machine_name</i> # |
| Bourne shell and Korn shell | \$ |
| Bourne shell and Korn shell superuser | # |
| LOM shell | lom> |
| OBP | ok |

Accessing Sun Documentation Online

A broad selection of Sun system documentation is located at:

<http://www.sun.com/products-n-solutions/hardware/docs>

A complete set of Solaris documentation and many other titles are located at:

<http://docs.sun.com>

Ordering Sun Documentation

Fatbrain.com, an Internet professional bookstore, stocks select product documentation from Sun Microsystems, Inc.

For a list of documents and how to order them, visit the Sun Documentation Center on Fatbrain.com at:

<http://www.fatbrain.com/documentation/sun>

Sun Welcomes Your Comments

We are interested in improving our documentation and welcome your comments and suggestions. You can email your comments to us at:

docfeedback@sun.com

Please include the part number of your document in the subject line of your email.

Safety Precautions

For your protection, observe the following safety precautions when setting up your equipment:

- Follow all cautions and instructions marked on the equipment.
- Never push objects of any kind through openings in the equipment. Dangerous voltages may be present. Conductive foreign objects can produce a short circuit that could cause fire, electric shock, or damage to your equipment.

Symbols

The following symbols may appear in this manual:



Caution – There is a risk of personal injury and equipment damage. Follow the instructions.



Caution – Hazardous voltages are present. To reduce the risk of electric shock and danger to personal health, follow the instructions.

Modifications to Equipment

Do not make mechanical or electrical modifications to the equipment. Sun Microsystems is not responsible for the regulatory compliance of a modified product.



Caution – Do not block or cover the openings of your Sun product. Never place a Sun product near a radiator or heat register. Failure to follow these guidelines can cause overheating and affect the reliability of your Sun product.



Caution – If your server is installed in a closed or multi-unit rack assembly, the operating ambient temperature of the rack environment may exceed the room ambient temperature. Ensure that rack environment ambient temperature does not exceed 40 degrees.



Caution – Mounting of the equipment in a rack or cabinet should be such that a hazardous condition is not created due to uneven mechanical loading or weight distribution.



Caution – Ensure that the connection of multiple system units to the circuit does not overload the supply overcurrent protection or supply wiring. Consider the Sun agency label electrical ratings when determining the correct branch circuit rating for your installation.



Caution – All supply connections, wiring, wire protection, and wire routing must be made in accordance with applicable sections and requirements of national electrical code and local electrical authorities.

PART I **Installation and Configuration**

Introducing the Sun Fire V100 Server

This chapter gives an overview of the Sun Fire V100 server. It lists the features of the server and the contents of the ship kit, and lists the optional components available. It also gives you an overview of the installation process.

The chapter contains the following sections:

- “Contents of the Ship Kit” on page 3
- “Preinstalled Software” on page 3
- “Optional Components” on page 4
- “Installation Quick Start” on page 5

Overview of the Sun Fire V100 Server

The Sun Fire V100 server is a single-processor server in a one rack unit (1 RU) chassis. It is designed to maximize the density of high-performance Solaris servers in a rack.



FIGURE 1-1 The Sun Fire V100 server

The server is ideal for:

- Internet service providers
- Telecommunications carriers
- Financial services
- Corporate customer networks
- Anyone who wants to maximize the density of Solaris servers in a rack

The Sun Fire V100 server has the following features:

- A removable system configuration card containing the server's host ID, MAC address, and NVRAM settings
- Rackmounting enclosure with single power supply
- Four DIMM sockets
- Two 10/100 Mbps RJ-45 Ethernet ports
- Console/Lights Out Management RJ-45 serial port
- Second RJ-45 serial port
- Two USB ports
- Support for up to two low-profile, 3.5-inch IDE disks
- Solaris operating environment (64 bit) preinstalled
- Slimline CD-ROM drive

Contents of the Ship Kit

The Sun Fire V100 server is supplied with the following components:

TABLE 1-1 Contents of the Ship Kit

| Item | Part Number | Quantity |
|--|-------------|----------|
| RJ-45 to RJ-45 patch cable for Ethernet or serial connection | 530-2093-xx | 2 |
| RJ-45 to DB-25 adapter | 530-2889-xx | 1 |
| RJ-45 to DB-9 adapter | 530-3100-xx | 1 |
| Rackmounting screws, 10-32x1/2 | 240-1207-xx | 8 |
| Front slide mount | 340-6125-xx | 2 |
| Rear slide mount | 340-6234-xx | 2 |
| Cable management bracket | 340-6151-xx | 1 |
| M4 nuts | 240-1373-xx | 4 |
| Rack screw kit | 565-1645-xx | 1 |
| Antistatic wrist strap | 250-1007-xx | 1 |
| <i>Sun Fire V100 Server User's Guide</i> | 816-2756-xx | 1 |
| <i>Sun Fire V100 Server Safety and Compliance Guide</i> | 816-2755-xx | 1 |
| <i>Sun Fire V100 Server Product Notes</i> | 816-2754-xx | 1 |

Preinstalled Software

The Sun Fire V100 server is preinstalled with the Solaris 8 operating environment (64 bit), including Lights-Out Management (LOM). The server will only support a 64 bit kernel, but applications written for a 32 bit environment can be used as long as they do not depend upon a 32 bit driver.

For more information on the specific release of Solaris 8 installed on your server, use the command below.

```
# cat /etc/release
```

Optional Components

Sun offers additional hard disk drives and memory modules for the server. To order them, contact your local Sun sales representative. See TABLE 1-2 for a list of components and part numbers. The server should be seen as a replaceable unit: if a fault occurs, contact your local Sun sales representative for a replacement.

TABLE 1-2 Customer Installable Hardware

| Optional Components | Part Number |
|------------------------------------|--------------------|
| 128-Mbyte DIMM | X7090A |
| 256-Mbyte DIMM | X7091A |
| 512-Mbyte DIMM | X7084A |
| 40 Gbyte, 7200 rpm hard disk drive | X7096A |

Installation Quick Start

| Task | See in the <i>Sun Fire V100 Server User's Guide</i> |
|---|---|
| 1 Install the Hardware | |
| Mount in the rack. | "Installing the Sun Fire V100 Server Into a Rack" on page 7 |
| Connect the cables. | "Connecting the Cables" on page 17 |
| Set up a console connection. | "Setting Up a Console Connection to the Server" on page 20 |
| 2 Configure the Server | |
| Note: The server is preinstalled with the Solaris 8 operating environment. | |
| Power on the server. | "Powering On and Configuring the Server" on page 34 |
| Manage the server from the <code>lom</code> or Solaris prompt. | "Remote and Local Management" on page 41 |
| 3 Further Information | |
| Reinstalling the Solaris software. | "Reinstalling the Solaris Operating Environment" on page 97 |
| Troubleshooting | "Diagnostic Tools" on page 100 |
| Solaris 8 documentation | http://docs.sun.com |

Installing the Sun Fire V100 Server Into a Rack

This chapter explains how to install the Sun Fire V100 server into a rack and describes the mounting options available. It also contains a guide on connecting the cables to the server. The information is provided in the following sections:

- “Choosing Between a Rack and a Cabinet” on page 8
- “Installing the Sun Fire V100 Server Into a 19-Inch Wide or 72-inch Tall Four-Post Rack” on page 8
- “Connecting the Cables” on page 17

Choosing Between a Rack and a Cabinet

The Sun Fire V100 server can be installed in either a rack or a cabinet. Factors that might influence your decision include:

- **Security**
If other people have access to the room in which your servers are located, you can increase security by locking the servers in a cabinet.
- **Thermal issues**
Cabinets often require additional fans, because the systems installed in them generate heat in an enclosed space. Two-post racks, however, may require no special cooling systems.
- **Flooring**
Two-post telco relay racks are designed so that cables can be run overhead. Cabinets often require cables to be run under the floor.

Installing the Sun Fire V100 Server Into a 19-Inch Wide or 72-inch Tall Four-Post Rack

The 19-Inch Rackmounting Kit

The mounting slides can each be used on either side of the rack. The parts required are listed in TABLE 2-1. The part number of the rackmounting kit is X6919A.

TABLE 2-1 19-inch Rackmounting Kit

| Item | Quantity | Part No. |
|--------------------------|----------|----------|
| Front slide | 2 | 340-6125 |
| Rear slide | 2 | 340-6234 |
| Cable management bracket | 1 | 340-6151 |
| M4 nuts | 4 | 240-1373 |
| Rack screw kit | 1 | 565-1645 |

A bracket is provided to aid cable management at the back of the server (see FIGURE 2-1). Use zip ties to secure the cables to the cable management bracket and hold them in place.

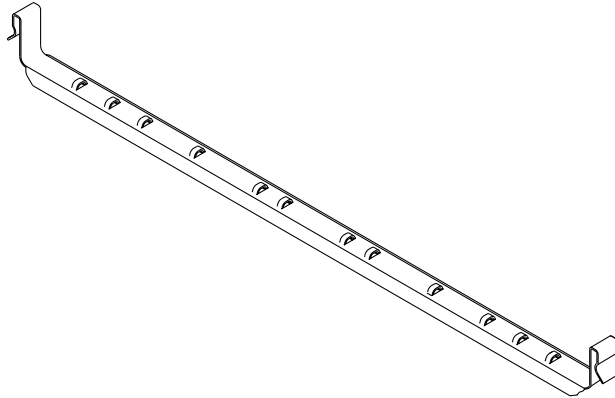

FIGURE 2-1 Cable Management Bracket

▼ To Assemble the Slides and Mount the Server

- 1. Position the two parts of the slide so that the double-angled ear (A) is in the correct position for the rack you are installing into.**
 - For the Sun StorEdge 72-inch tall (19-inch wide) rack, the double-angled ear (A) must be to the rear (see FIGURE 2-2).

- For a standard 19-inch wide rack, the double-angled ear (A) must be to the front (see FIGURE 2-3).

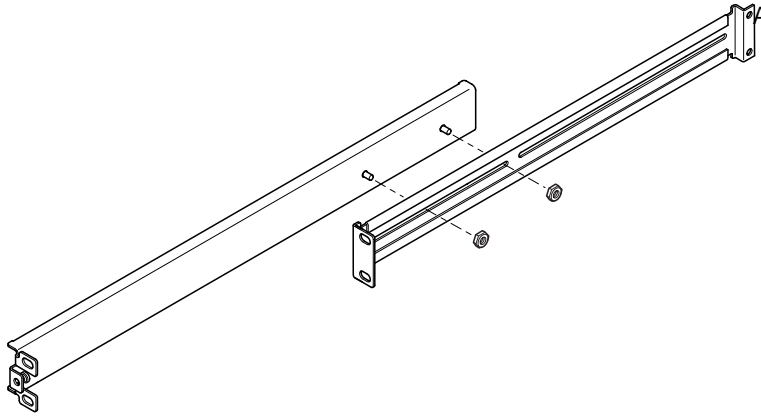

FIGURE 2-2 Positioning the Slide Mounts for a Sun StorEdge 72-Inch Tall Rack

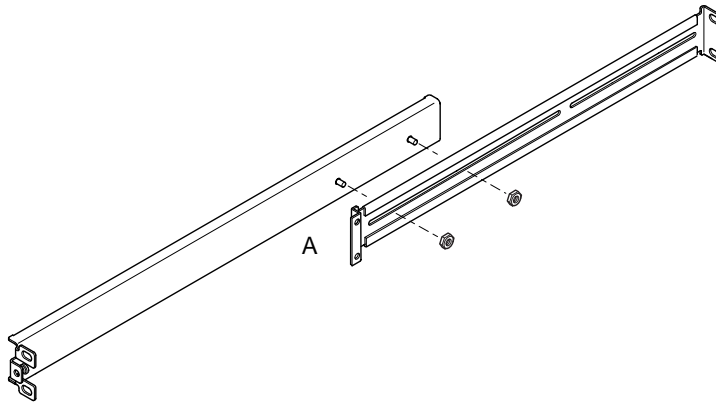

FIGURE 2-3 Positioning the Slide Mounts for a Standard 19-Inch Wide Rack

2. Loosely screw the two parts of the slide mounts together using the M4 nuts supplied.
3. Measure the distance between the front and back posts of your rack.
4. Adjust the slide mounts so that the distance between the front and back mounting ears is approximately the distance between the front and back posts of the rack.

5. Move the brackets so that the studs are in suitable slots and tighten the nuts.

6. Fasten the mounting slides to the rack using the screws supplied.

For the Sun StorEdge 72-inch rack, refer to FIGURE 2-4 and FIGURE 2-5. Leave the screws slightly loose to allow adjustment when you slide the server into the rack.

For a standard 19-inch rack, refer to FIGURE 2-6. Leave the screws slightly loose to allow adjustment when you slide the server into the rack.

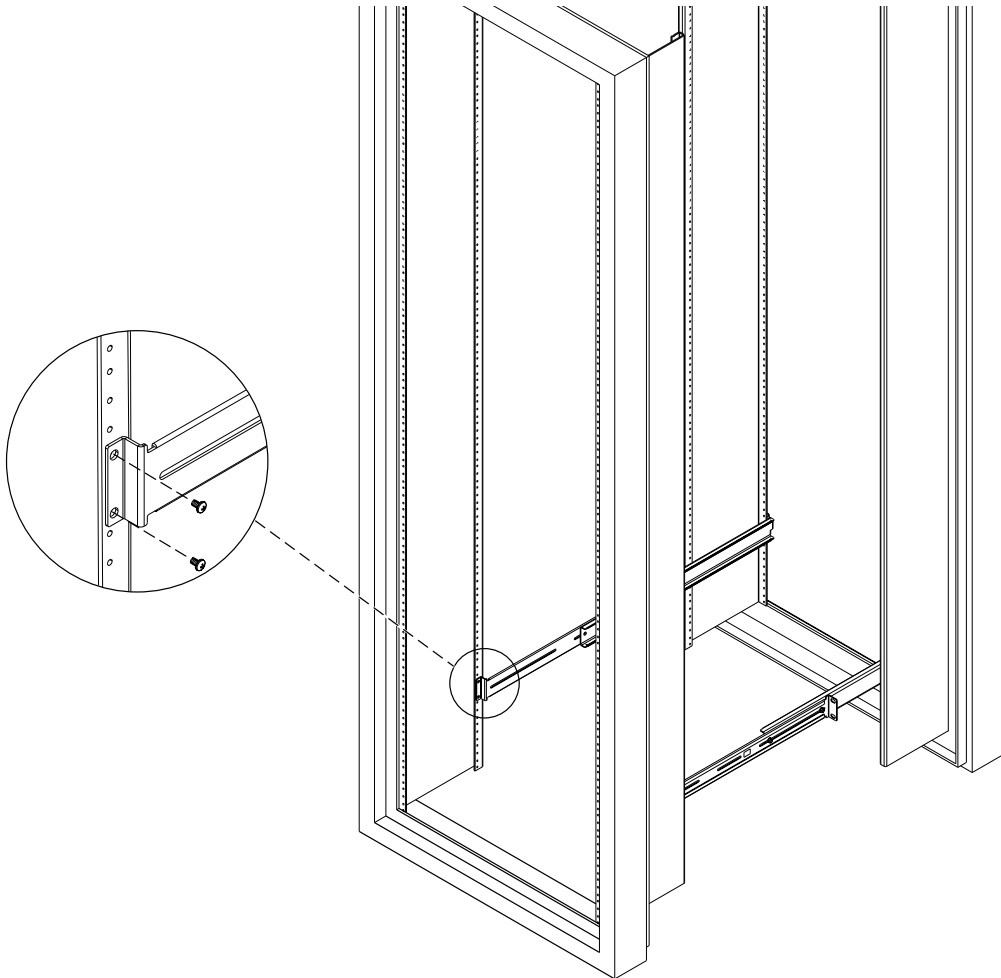

FIGURE 2-4 Fastening the Slide Mounts to a Sun StorEdge 72-inch Tall Rack – Rear View (Side Panels Removed for Clarity)

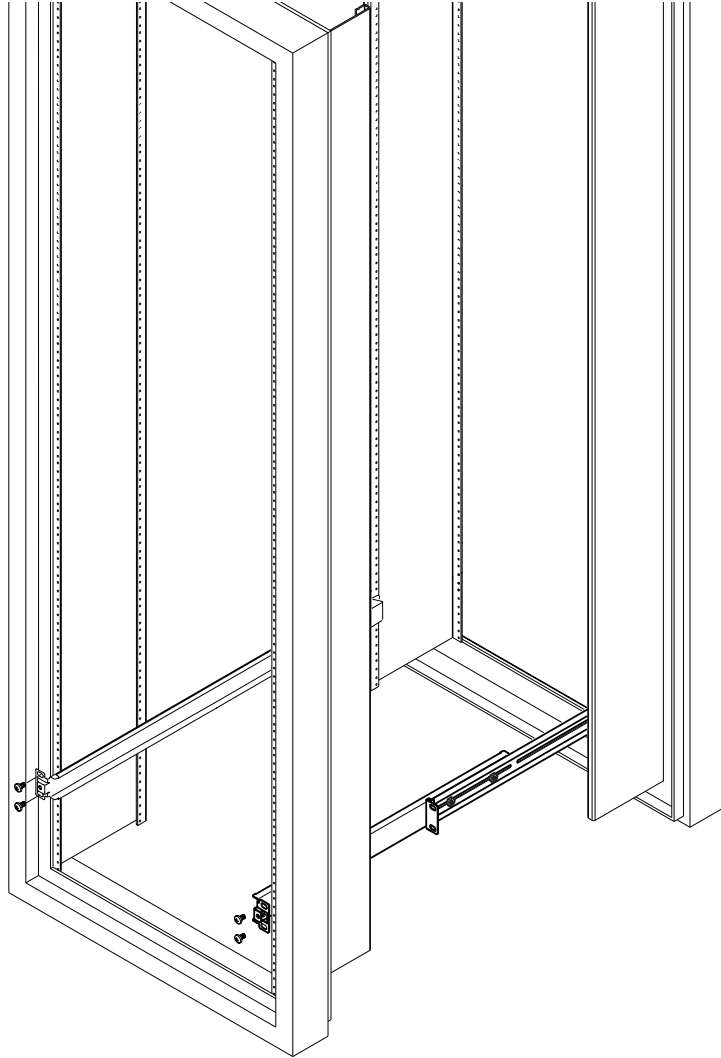

FIGURE 2-5 Fastening the Slide Mounts to a Sun StorEdge 72-inch Expansion Rack – Front View (Side Panels Removed for Clarity)

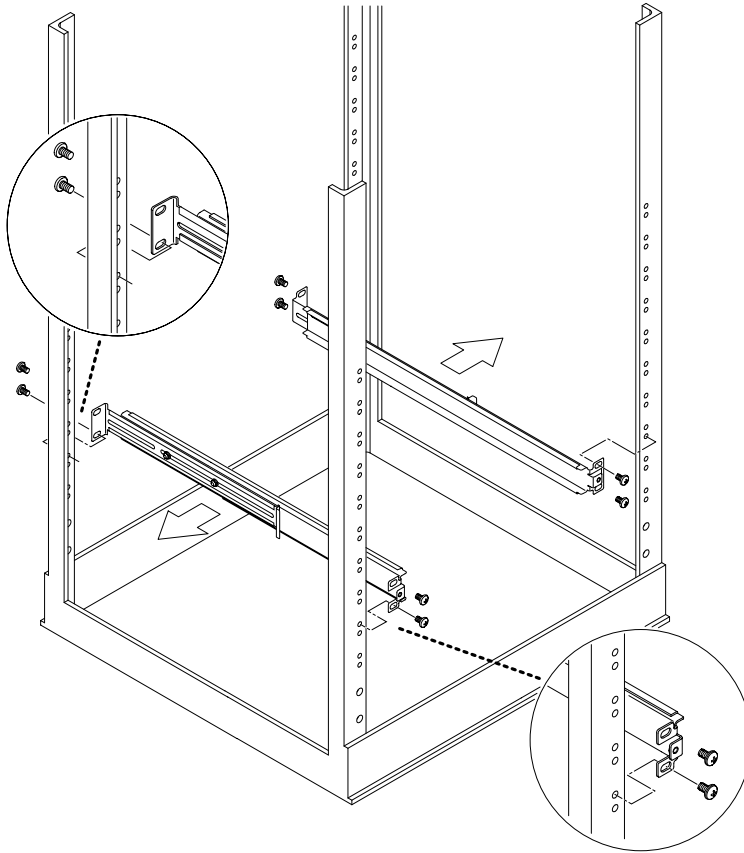

FIGURE 2-6 Fastening the Slide Mounts to a Standard 19-inch Rack

7. Slide the server into the rack (see FIGURE 2-7).

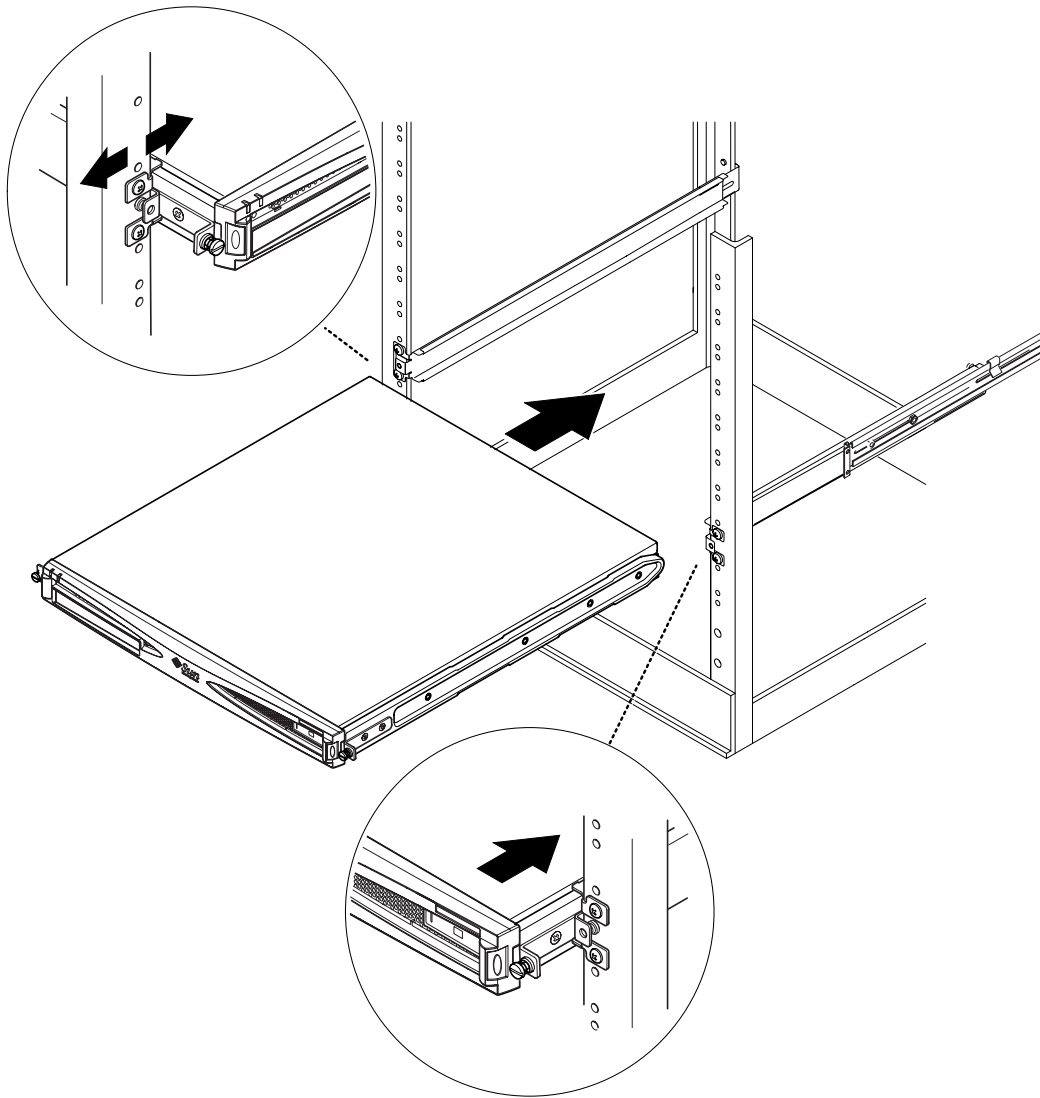

FIGURE 2-7 Sliding the Sun Fire V100 Server Into a Standard 19-Inch Rack

8. **Align the thumbscrews on the sides of the server with the slide mounts in the rack (see FIGURE 2-8).**

If necessary, readjust the slide mounts to align the server properly. The thumbscrews need to be finger-tight.

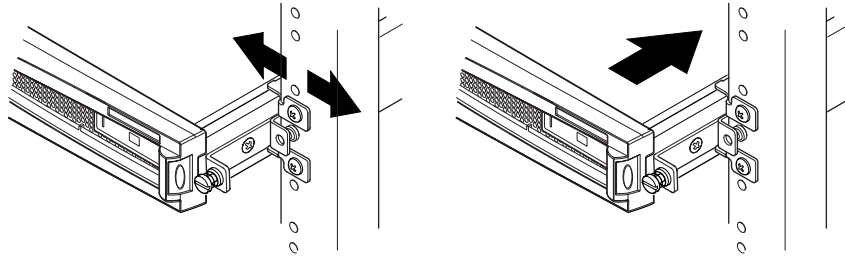

FIGURE 2-8 Adjusting the Slide Mounts and Screwing the Server Into the Rack

9. **Tighten the slide mounts in the rack if you have not fully secured them yet.**
10. **When the slide mounts are secure, use a screwdriver to tighten the thumbscrews on the side of the server.**

The server is now securely installed in the rack.

▼ To Fit the Cable Management Bracket

- **Hook the bracket over the slide mounts at the rear of the server (see FIGURE 2-9).**
You can use the loops in the bracket to secure the cables with cable ties.

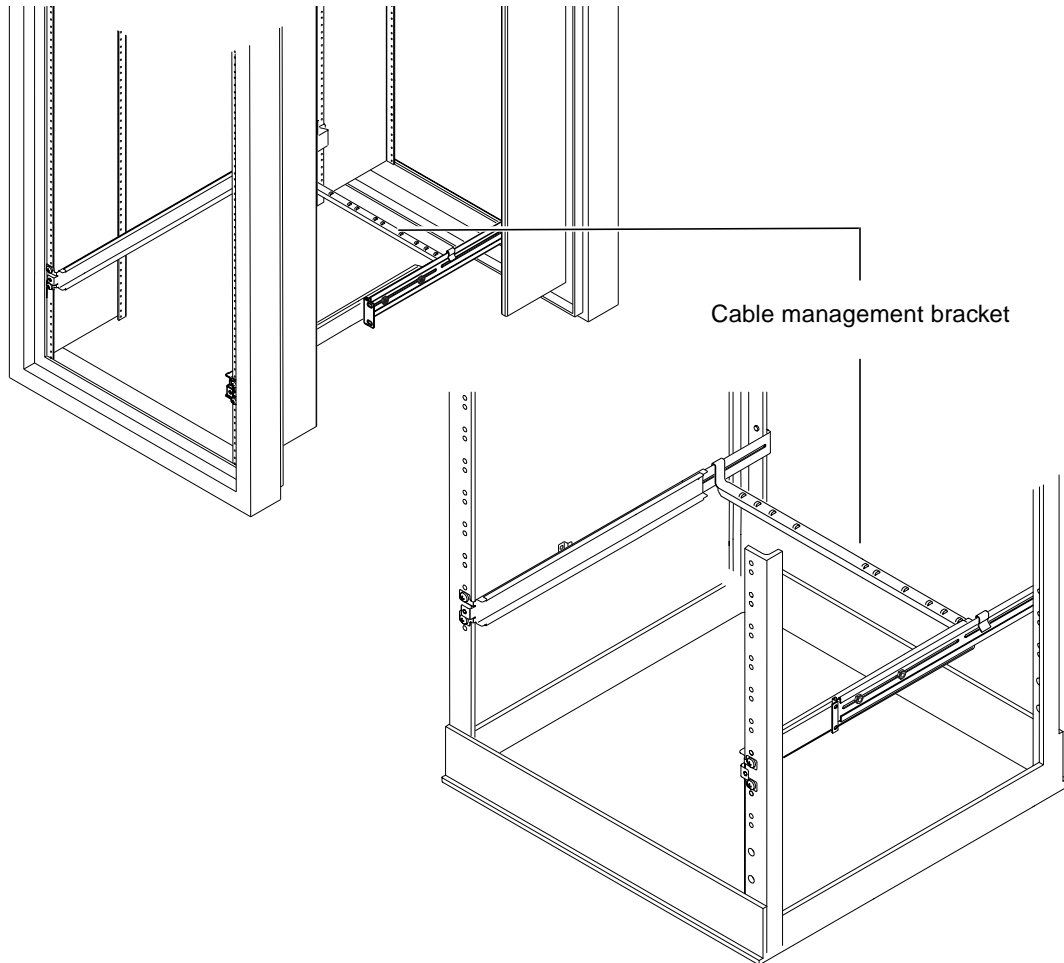

FIGURE 2-9 Fitting the Cable Management Bracket to a Sun StorEdge or a Standard 19-Inch Rack

Tips for Using a Sun StorEdge 72-inch Rack

- For maximum stability, fill the rack from the bottom up and at the top leave at least four rack units empty.
- To prevent warm air flowing to the front of the rack and being recirculated (which would reduce the efficiency of your cooling system and potentially cause overheating), close off the empty spaces at the top of the rack with filler panels. The following filler panels are available from your local Sun sales representative:

- 1 RU (part number: 330-2610-01)
 - 2 RU (part number: 330-2611-01)
 - 3 RU (part number: 330-2613-01)
 - 4 RU (part number: 330-2614-01)
 - 5 RU (part number: 330-2615-01)
- Position your racks so that the warm air exhaust from one rack does not flow directly into the cool air intake area for another.
 - If space is limited at the back of your Sun StorEdge 72-inch rack, install a redundant fan tray (part number: X9819A) into the top of the rack. This pulls air through the top of the rack to prevent the build-up of heat behind it.

Connecting the Cables

The following section describes the positions of the ports and sockets for the corresponding cables, and the correct procedure for connecting the cables.

The server's ports are arranged and numbered as in FIGURE 2-10.

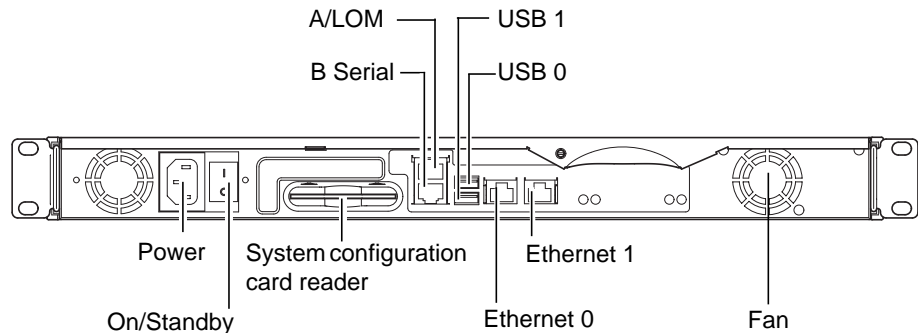

FIGURE 2-10 The Server's Back Panel

▼ To Connect the Cables to the Server

1. **Connect the power cord.**

2. Connect a serial device.

For more information, see “Setting Up a Console Connection to the Server” on page 20.

If you want to use the server’s Lights Out Management (LOM) facilities, use the port labeled Serial A/LOM to make your serial connection to the server.

Note – The Sun Fire V100 server is supplied with shielded serial cables. Use only these cables when making serial connections to the server.

3. Connect the server to a maximum of two Ethernet hubs.

You need connect to an Ethernet hub only if you intend to use the server in a network.

4. Connect the server to a maximum of two USB devices.

If required.

5. If you intend to configure the server directly from a dumb terminal or a Sun workstation, connect the serial cable into the DB-25 serial adapter that was supplied with the server, and connect the adapter to the serial connector on the terminal or on the Sun workstation.

Refer to Chapter 4 for information about powering on the system.

Note – The DB-25 serial adapter may not work with all terminals. If you have problems, refer to your terminal manual to check its compatibility with the Sun adapter.



Caution – AC-powered Sun products are designed to work with single-phase power systems that have a grounded neutral conductor. To reduce the risk of electric shock, do not connect Sun products to any other type of power system. Contact your facilities manager or a qualified electrician if you are not sure what type of power is supplied to your building.



Caution – Your AC-powered Sun product is packaged with a grounding type (three-wire) power cord. To reduce the risk of electric shock, always connect the cord to a grounded outlet.

Communicating With the Server

This chapter provides information on setting up a console connection to a Sun Fire V100 server using a variety of devices. The information is contained in the following sections:

- “Setting Up a Console Connection to the Server” on page 20
- “Connecting to the Server Using a Sun Workstation or ASCII Terminal” on page 23
- “Connecting to the Server Using a Terminal Server” on page 25
- “Connecting to the Server Using a System Running Microsoft Windows” on page 27
- “Connecting to the Server Using a Handheld Device” on page 29

Setting Up a Console Connection to the Server

To perform the initial configuration and to continue to monitor and manage a server, you can connect any of the following devices to the appropriate serial port on the server's back panel:

- Sun workstation or ASCII terminal connected directly to the server
- Sun workstation connected via a terminal server
- Modem
- PC
- Handheld device

Which Is the Appropriate Serial Port?

There are two serial ports on the rear of the Sun Fire V100 server. TABLE 3-1 lists the serial port labels and function of each port.

TABLE 3-1 Server Serial Ports

| Serial Port | Purpose | Description |
|-------------|---|---|
| A LOM | Issue LOM commands | This port is dedicated to the Lights Out Management (LOM) device in the server. |
| B Serial | <ul style="list-style-type: none">• Perform binary data transfers• Set up a modem connection | Communication on the A/LOM port is subject to interruption by the LOM device, therefore the A/LOM port does not assert the constant DTR signal required by a modem. |

Serial Port Pin Arrangement

When viewed from the back of the server, the pin arrangement of the RJ-45 ports is as shown in FIGURE 3-1.

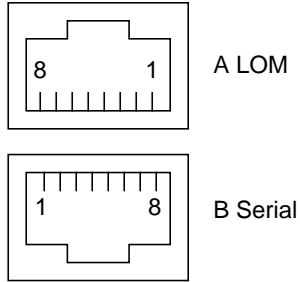

FIGURE 3-1 Serial Port Pins 1 to 8

Serial Connection Settings

The settings you need to use for a serial connection are listed in TABLE 3-2. If you need to perform binary data transfers (that is, transfers of anything more than simple ASCII character streams), use the B Serial port, as communication on the A LOM port is subject to interruption by the LOM device (see “Introduction to Lights-Out Management” on page 43).

TABLE 3-2 Settings for Connecting to the Serial A/LOM or Serial B Port

| Parameter | Setting |
|-----------|---|
| Connector | Serial A/LOM or Serial B (use Serial B for binary data transfers) |
| Rate | 9600 baud |
| Parity | No |
| Stop bits | 1 |
| Data bits | 8 |

Serial Adapters

Depending on the type of device you use to connect to the server, you could need to use either a DB-25 or DB-9 serial adapter. TABLE 3-3 describes which type to use, and the following sections describe the crossovers each adapter performs.

TABLE 3-3 Serial Adapters

| Terminal Device | Adapter |
|---|----------------------------------|
| Sun workstation, ASCII terminal, or terminal server | DB-25 |
| PC or laptop | DB-9 (female, supplied by Sun) |
| Handheld device | DB-9 (male, not supplied by Sun) |

The Sun DB-25 Adapter

To connect to a Solaris `tip` session or to a VT100 terminal, you need to use either the DB-25 (25-Pin DSUB Male to 8-POS RJ-45 Female) adapter that is supplied by Sun (part no. 530-2889) with your system, or an alternative adapter that performs the same pin crossovers. The Sun-supplied DB-25 adapter enables you to connect to any Sun system. The crossovers it performs are listed in TABLE 3-4.

TABLE 3-4 Pin Crossovers in the Sun DB-25 (25-Pin) Adapter

| Serial Port (RJ-45 Connector) Pin | 25-Pin Connector |
|-----------------------------------|-----------------------|
| Pin 1 (RTS) | Pin 5 (CTS) |
| Pin 2 (DTR) | Pin 6 (DSR) |
| Pin 3 (TXD) | Pin 3 (RXD) |
| Pin 4 (Signal Ground) | Pin 7 (Signal Ground) |
| Pin 5 (Signal Ground) | Pin 7 (Signal Ground) |
| Pin 6 (RXD) | Pin 2 (TXD) |
| Pin 7 (DSR) | Pin 20 (DTR) |
| Pin 8 (CTS) | Pin 4 (RTS) |

▼ To Use the DB-25 Adapter

1. Insert one end of the standard RJ-45 patch cable supplied with the Sun Fire V100 server into one of the server's serial ports.
2. Insert the other end of the RJ-45 patch cable into the supplied DB-25 adapter.
3. Attach the adapter to the appropriate port in your serial device.

The Sun DB-9 Adapter

Some devices, such as a PC or handheld computer, require you to use either a male or female DB-9 adapter. The Sun DB-9 adaptor (part number 530-3100-xx) is a 9-Pin DSUB female to 8-POS RJ-45 female adapter. To connect to any device that has a 9-pin serial connector, use a DB-9 (9-pin) adapter that performs the pin crossovers listed in TABLE 3-5.

TABLE 3-5 Pin Crossovers in the DB-9 (9-Pin) Adapter

| Serial Port (RJ-45 Connector) Pin | 9-Pin Connector |
|-----------------------------------|-----------------------|
| Pin 1 (RTS) | Pin 8 (CTS) |
| Pin 2 (DTR) | Pin 6 (DSR) |
| Pin 3 (TXD) | Pin 2 (RXD) |
| Pin 4 (Signal Ground) | Pin 5 (Signal Ground) |
| Pin 5 (Signal Ground) | Pin 5 (Signal Ground) |
| Pin 6 (RXD) | Pin 3 (TXD) |
| Pin 7 (DSR) | Pin 4 (DTR) |
| Pin 8 (CTS) | Pin 7 (RTS) |

Connecting to the Server Using a Sun Workstation or ASCII Terminal

To connect to the server using either a Sun workstation or an ASCII terminal, you need:

- DB-25 adapter

- RJ-45 to RJ-45 patch cable

Both are supplied with the Sun Fire V100 server.

▼ To Connect to the Server Using a Sun Workstation

1. **Connect to the server using the RJ-45 patch cable and DB-25 adapter as described in “To Use the DB-25 Adapter” on page 23.**
2. **From a terminal session, type:**

```
# tip /dev/term/a -9600
```

The `tip` command above is for a console that is using its `ttya` serial port. If you later configure your console to use `ttyb`, type the following to set up a `tip` session:

```
# tip /dev/term/b -9600
```

For information about dedicating the console to Serial B, see “Managing the Sun Fire V100 Server From the `lom>` Prompt” on page 43.

For information about how to power on and configure the server, go to “Powering On and Configuring the Server” on page 34.

▼ To Connect to the Server Using an ASCII Terminal

1. **Set up a connection between the terminal and the Sun Fire V100 server.**
See “To Use the DB-25 Adapter” on page 23.
2. **For the General terminal settings, refer to the terminal operating manual.**

3. Make the setting changes shown below.

| Property | Setting |
|-----------------|--------------------|
| Duplex | Full |
| Bit Rate | 9600 |
| Parity | No |
| Data Bits | 8 |
| Stop Bit | 1 |
| Flow Control | Xon/Xoff |
| VT100 Emulation | On (if applicable) |

The `lom>` prompt appears.

For information about how to power on and configure the server, go to “Powering On and Configuring the Server” on page 34.

Connecting to the Server Using a Terminal Server

The pinouts for the Sun Fire V100 server’s serial ports correspond with the pinouts for the RJ-45 ports on the Asynchronous Serial Interface Breakout Cable supplied by Cisco for use with the Cisco AS2511-RJ terminal server. You can also use terminal servers made by other manufacturers, but check the documentation to see if the serial port pinouts of the Sun Fire V100 server match those of the terminal server you plan to use.

Connecting to a Cisco Terminal Server

The serial ports on the Sun Fire V100 server are DTE ports. If you connect these to other DTE ports, then the cabling between them must perform a crossover (also known as a roll-over).

The pinouts for the server’s serial ports correspond with the pinouts for the RJ-45 ports on Cisco terminal servers. This means that if you are using a Cisco Terminal Server (and you are connecting the Sun Fire V100 server to it using the Cisco Asynchronous Serial Interface Breakout Cable), you have two connection options:

- Connect the breakout cable directly to the Sun Fire V100 server.
- Connect the breakout cable to a patch panel and use the straight-through patch cable (supplied by Sun) to connect the patch panel to the server.

Connecting to Other Terminal Servers

For terminals from other manufacturers, check the documentation to see if the pinouts of the serial ports on the Sun Fire V100 server match those of the serial ports on your terminal server. If they do not, you need to make a crossover (null-modem) cable that takes each pin on the Sun Fire V100 server's serial port to the corresponding pin in the terminal server's serial port.

TABLE 3-6 shows the crossovers that the cable must perform.

TABLE 3-6 Pin Crossovers for Connecting to a Typical Terminal Server

| Sun Fire V100 Serial Port (RJ-45 Connector) Pin | Terminal Server Serial Port Pin |
|---|---------------------------------|
| Pin 1 (RTS) | Pin 1 (CTS) |
| Pin 2 (DTR) | Pin 2 (DSR) |
| Pin 3 (TXD) | Pin 3 (RXD) |
| Pin 4 (Signal Ground) | Pin 4 (Signal Ground) |
| Pin 5 (Signal Ground) | Pin 5 (Signal Ground) |
| Pin 6 (RXD) | Pin 6 (TXD) |
| Pin 7 (DSR) | Pin 7 (DTR) |
| Pin 8 (CTS) | Pin 8 (RTS) |

▼ To Connect to a Sun Fire V100 Server Using a Terminal Server

1. Attach the appropriate crossover cables as described in “Connecting to a Cisco Terminal Server” on page 25 or “Connecting to Other Terminal Servers” on page 26.
2. Open a terminal session on the Sun workstation, and type:

```
# telnet IP-address-of-terminal-server port-number
```

For example, for a Sun Fire V100 server connected to port 10000 on a terminal server whose IP address is 192.20.30.10, you would type:

```
# telnet 192.20.30.10 10000
```

Connecting to the Server Using a System Running Microsoft Windows

If you want to configure and operate a Sun Fire V100 server from a PC or laptop running Microsoft Windows, you can do so using the Windows Hyperterminal.

Note – The following procedure relates to Windows 98. Other variants of Microsoft Windows may differ slightly.

Note – If you use a Palm Pilot or similar device, make sure that Hot Sync Manager is closed. If it is not closed, you will not be able to communicate with the server from your PC or laptop.

▼ To Connect to the Server

1. Connect the RJ-45 patch cable to the port labeled “A LOM” on the rear of the server.
2. Connect the other end of the patch cable to the DB-9 adapter.
3. Connect the DB-9 serial adapter to the COM1 serial port on your PC or laptop.
4. Open a Windows Hyperterminal:
 - a. Choose Start > Programs > Accessories > Communications > Hyperterminal
 - b. Run `Hypertrm.exe`
5. In the Set Up New Session window:
 - a. Name the session.
 - b. Choose an icon.

c. Click OK.

6. In the Connect To window:

a. Click Edit.

b. Click Connect Using.

c. In the drop-down menu, click Direct to COM1.

Note – If you connected the DB-9 adaptor to a port other than COM1 on your PC or laptop in Step 3, choose the appropriate option from the list in the drop-down menu.

d. Click OK.

7. In the COM1 Properties window:

a. Change the Bits Per Second value to 9600.

b. Set Flow Control to Xon/Xoff.

The correct values for all settings in this window are as shown below.

| Property | Setting |
|-----------------|----------|
| Bits Per Second | 9600 |
| Data Bits | 8 |
| Parity | None |
| Stop Bits | 1 |
| Flow Control | Xon/Xoff |

c. Click OK.

The `lom>` prompt now appears in the Windows Hyperterminal. For information about how to power on and configure the server, go to “Powering On and Configuring the Server” on page 34.

Connecting to the Server Using a Handheld Device

The Sun Fire V100 server can be configured from a handheld device that uses PalmOS 2.0 or later, as long as you have VT100 terminal emulation software installed on the device and the correct hardware with which to connect to the server.

▼ To Set Up the Hardware

Note – To connect a handheld device to a Sun Fire V100 server you need a *male* DB-9 adapter that performs the same crossovers as those listed in TABLE 3-5.

1. **Connect the RJ-45 cable supplied with the server to the server's A LOM port.**
2. **Connect the other end of the cable to the DB-9 adapter.**
3. **Connect the DB-9 adapter to the serial cable leading to your PalmOS device's cradle or travel kit.**

▼ To Set Up the Software

Note – To configure the Sun Fire V100 server from a handheld device, you need VT100 emulation software installed. The following procedure was based on a package called "Online" which is available from <http://www.markspace.com/online.html#Getting>. This web address also gives you information on installing and using the software.

Once the program is installed:

1. **Go to the Applications menu.**
2. **Click the Online icon.**

3. Choose Menu > Options > Communications and make the following settings.

This ensures correct communication with the server.

| Property | Method |
|-----------------|---------------|
| Method | Serial |
| Port | Serial |
| Baud Rate | 9600 |
| Data Bits | 8 |
| Parity | None |
| Stop Bits | 1 |
| RTS/CTS | Unchecked |
| Xon/Xoff | Unchecked |

4. Choose Menu > Options > Terminal and make the following settings:

| Property | Method |
|------------------------|---------------|
| Emulate | TTY |
| Font | Small |
| Return | LF |
| Backspace | BS |
| Add LF | Unchecked |
| Display follows cursor | Checked |
| Autowrap to next line | Unchecked |
| Local echo/Pacing | Unchecked/Off |

5. Click On.

This starts the software's online mode.

Tip – If the screen prompt does not appear immediately, try pressing the Return key. The prompt should appear.

You can now configure the Solaris operating environment and manage the server through the handheld device's terminal emulator. For information on how to power on and configure the server, go to "Powering On and Configuring the Server" on page 34.

The following sections give some additional information that may make using the handheld device's terminal emulator easier.

Using the Arrow Keys

The arrow keys available on the PalmOS device do not work with a Sun Fire V100 server. To work around this problem, specify while you configure the Solaris operating environment that you are using an Xterm device.

The following keystrokes help you navigate the menus.

| Keystroke | Action |
|---------------|---|
| Ctrl-F or Tab | Go forward to the next option (down). |
| Ctrl-B | Go back to the previous option (up). |
| Space | Select option (X). |
| Esc- <i>n</i> | Go to the next or previous screen, where <i>n</i> is indicated at the bottom of the screen. Use this instead of the function (Fn) keys. |

▼ To Use Macros

You can manage the server more efficiently by setting macros up in the terminal emulator as follows:

- 1. Choose Menu > Options > Macro.**
- 2. Define a name for the macro.**
- 3. Specify the text that the macro will execute.**
- 4. End the text of each macro with “\n”.**

This indicates a return signal, and executes the macro.

Table 3-7 shows some example macros.

TABLE 3-7 Example PalmOS Terminal Emulator Macros

| Macro Name | Command | Action |
|-------------------|---|---|
| backspace | <code>stty erase ^H\n</code> | Enables the Graffiti stroke for “delete” to work on the screen without printing the ^H character. |
| arrow-enable | <code>csH;setenv TERM dtterm\n</code> | Switch to <code>csH</code> and set the terminal variable to <code>dtterm</code> . This enables the on-screen arrows to work on applications such as <code>vi</code> . |

Powering On and Configuring the Sun Fire V100 Server

This chapter explains how to power on and configure the server, and how to use the Power (On/Standby) switch. The chapter contains the following sections:

- “Powering On and Configuring the Server” on page 34
- “Using the Power (On/Standby) Switch” on page 39

Powering On and Configuring the Server

The Sun Fire V100 server comes preinstalled with the Solaris 8 operating environment. When you power on the server for the first time, you will automatically be taken through a configuration procedure. This procedure consists of a number of questions. The answers you give determine how the server is configured.

Choose the configuration that best suits your requirements from the list below, and follow the instructions in the appropriate section to power on and configure your server.

- “To Power On With the Server’s Details Registered at a Name Server” on page 34
- “To Power On Without the Server’s Details Registered at a Name Server” on page 35
- “To Power On a Standalone Server for the First Time” on page 37
- “To Clear the Configuration and Start Again” on page 37

Note – Do not use the power On/Standby switch on the back of the server to power on. You power on from the keyboard, and that step is included in these instructions.

Before configuring a Sun Fire V100 server:

- Connect the server to a power source (see “Connecting the Cables” on page 17).
- Set up a serial connection to the server using one of the serial ports on the server’s back panel and your choice of workstation (see “Setting Up a Console Connection to the Server” on page 20).

▼ To Power On With the Server’s Details Registered at a Name Server

Note – Follow the instructions in this section only if you have a name server installed on your network. For instructions on using a name server to automate the process of configuring the Solaris operating environment on multiple servers, refer to the Solaris *Advanced Installation Guide* that accompanies the Solaris operating environment CDs.

1. **Connect the server to the power supply but do not power it on.**
2. **Set up a serial connection to the Serial A/LOM port and also a connection to at least one Ethernet hub (as described in Chapter 3).**
3. **At the console `lom>` prompt, type the following command to power on the server:**

```
lom> poweron
```

For more information about the `lom>` prompt and the commands that are available from it, see Chapter 5.

During booting you will be prompted for certain information. The information you provide determines the configuration of the server.

4. **Specify the type of terminal you are using to communicate with the Sun Fire V100 server.**
5. **Specify whether you need IPv6 enabled, and then follow the instructions on the screen.**
6. **Specify whether you want to enable the Kerberos Security mechanism, and then follow the instructions on the screen.**
7. **When prompted, give a password (if any) for users logging in as root.**

The system will boot when you have provided it with the information it needs.

▼ To Power On Without the Server's Details Registered at a Name Server

Follow the instructions in this section if you do not have a Name Server configured on your network.

Tip – Read these instructions through before you follow them, to see what information the system will prompt you for when you start it for the first time.

1. **Connect the server to the power supply but do not power it on.**
2. **Set up a serial connection to the Serial A/LOM port and also a connection to at least one Ethernet hub (as described in Chapter 3).**

3. At the `lom>` prompt, type the following command to power on the server:

```
lom> poweron
```

For more information about the `lom>` prompt and the commands that are available from it, see Chapter 5.

During booting you will be prompted for certain information. The information you provide determines the configuration of the server.

4. Specify the type of terminal you are using to communicate with the Sun Fire V100 server.
5. When asked if you want the server to be networked, answer Yes.
If manually, specify an IP address when prompted.
6. Specify whether the IP address is to be configured by DHCP.
7. Specify which of the Ethernet ports you intend to use as the primary Ethernet connection.
For the port labelled Net0, specify `eri0`. For the port labelled Net1, specify `eri1`.
8. Specify a host name for the server.
9. If prompted, specify the IP address for the system.
The system prompts you for this address if you declined to use DHCP in Step 6. It also asks you whether the server is to be part of a subnet, and if you answer Yes it prompts you to provide the netmask of the subnet.
10. Specify whether you need IPv6 enabled, and then follow the instructions on the screen.
11. Specify whether you want to enable the Kerberos Security mechanism, and then follow the instructions on the screen.
12. Specify the name service you want the server to use.
13. Specify the name of the domain of which the server will be a part.
14. Specify whether you want the system to search the network for a name server or whether you want it to use a particular name server.
15. If you chose to use a particular name server, specify the host name and IP address of the name server.
16. At the name server, create entries in the network administration files for the system you are setting up.

17. At the system you are setting up, follow the prompts to provide time and date information.
18. When prompted, give a password (if any) for users logging in as root.

The system will boot when you have provided it with the information it needs.

▼ To Power On a Standalone Server for the First Time

1. Connect the server to the power supply but do not power it on.
2. Set up a serial connection using the Serial A/LOM port (as described in “Setting Up a Console Connection to the Server” on page 20).
3. At the `lom>` prompt, type the following command to power on the server:

```
lom> poweron
```

For more information about the `lom>` prompt and the commands that are available from it, see Chapter 5.

4. Specify the type of terminal you are using to communicate with the Sun Fire V100 server.
5. When prompted to indicate whether you want the server to be networked, specify No.
6. Specify a Host Name for the server.
7. Confirm the information you have given.
8. Specify the date and time information.
9. When prompted, give a password (if any) for users logging in as root.

The system will boot when you have provided it with the information it needs.

▼ To Clear the Configuration and Start Again

If you want to start the power on process again, as if from a previously unused server, you must clear the configuration of the server.

- If you are at the `lom>` prompt, go to the `ok` prompt by typing:

```
lom> break
```

1. Boot the server into the Solaris environment by typing:

```
ok boot
```

2. At the Solaris prompt, type:

```
# sys-unconfig
```

3. When prompted to confirm that you want to create a “blank” server, type `y`.
4. When the server has unconfigured itself, type the LOM escape sequence. By default, this is:

```
# #.
```

When the `lom>` prompt appears, follow the instructions in one of the following sections:

- “To Power On With the Server’s Details Registered at a Name Server” on page 34 or
- “To Power On Without the Server’s Details Registered at a Name Server” on page 35.
- “To Power On a Standalone Server for the First Time” on page 37

Using the Power (On/Standby) Switch



Caution – The power switch on the back panel of the Sun Fire V100 server is not an On/Off switch, it is an On/Standby switch. It does not isolate the equipment.

The power (On/Standby) switch is a rocker type, momentary action switch. It controls only low-voltage signals; no high-voltage circuits pass through it. This means that the main method of connecting or disconnecting power is by inserting or removing the power supply cord. The server contains no integral circuit breakers: to isolate a server, you must break all connections to it. If you do not do this by removing the power supply cord, you must instead open all external circuit breakers.



On / Standby switch

FIGURE 4-1 Sun Fire V100 Server Power (On/Standby) Switch

The symbols on the switch are:

 **On**

- Press to apply power to the server.



Standby

- Press for less than four seconds to initiate an orderly shutdown of the system into Standby mode.
- Press and hold down for more than four seconds to leave only the LOM and certain battery backed functions running.

As long as there is a power cable connected to a server, then the server is either powered on or in standby power mode. To power the server on, or return it to standby power mode only, use either of the following methods:

- Issue commands from the `lom>` prompt.
- Press the rocker switch.

To completely remove power from the server:

- Disconnect the power cable from the server.

PART **II** **Remote and Local Management**

Managing the Sun Fire V100 Server From the lom> Prompt

This chapter introduces the Lights-Out Management (LOM) facilities available for the Sun Fire V100 server and describes how to use the `/usr/sbin/lom` utility, which provides a user interface to the device. The chapter contains the following sections:

- “Introduction to Lights-Out Management” on page 43
- “Powering On or Resetting the Server From the LOM Shell” on page 45
- “Monitoring the Server From the LOM Shell” on page 49
- “Setting Up LOM Privileges for Named Users” on page 54
- “Setting the LOM Configurable Variables” on page 58
- “Separating LOM From the Console on the Serial A/LOM Port” on page 60
- “Viewing Event Reports That LOM Sends to syslogd” on page 61
- “LOM Shell Command List” on page 62

Note – For information about how to configure the LOM device-driver, see Appendix B.

Introduction to Lights-Out Management

Lights-Out Management (LOM) commands allow you to remotely manage a server that is deployed in a “lights-out” environment. You can also use LOM commands to perform quick onsite management tasks at a locally connected terminal.

LOM commands enable you to:

- Power the server on or to standby mode.
- Monitor the server's temperature and the status of its power supply, fans, internal voltage rails, fault LED, and alarms, even when the server is in standby mode.
- Turn a Fault LED on.
- Configure the server to restart automatically after a lockup.

These LOM facilities are provided by the LOM device, which in the Sun Fire V100 server is contained on the system board. As long as the server is connected to a power supply, even if it is not powered on, you will see the `lom>` prompt at your terminal. This is because the LOM device uses standby power and remains active even when the server is not powered on.

There are two ways to interrogate the LOM device or to send it commands to perform. You can do either of the following:

- Issue LOM commands from the `lom>` shell prompt. (Explained in this chapter.)
- Issue LOM-specific Solaris commands from the console prompt. (Explained in Chapter 6.)

Using LOM Commands

To use the LOM facilities either remotely or locally, first establish a terminal connection to the A LOM port on the server. For details on how to do this, see “Setting Up a Console Connection to the Server” on page 20.

With the server connected to a power source, but not powered on, and with a terminal connected to the A LOM port, you will see the `lom>` prompt.

When you power on the server, the prompt will change to the Solaris console prompt. For details on how to get back to the `lom>` prompt, see “To Display the `lom>` Prompt” on page 46.

Powering On or Resetting the Server From the LOM Shell

Note – When a Sun Fire V100 server is connected to a power supply, it is always either fully powered on or in standby mode. To remove power entirely from the server you must disconnect its power cables or open all external circuit breakers. The methods referred to in this chapter for powering the server on and off by using `lom>` prompt commands are methods either of powering the server on or returning it to standby power mode. The `poweroff` command does not power the server off completely.

Note – All commands that involve powering on or off, resetting, or specifying the boot mode of the server require you or the named user to have `r`-level LOM user permission. If you have not set up any named users of the LOM device, then you have `r`-level permission by default. If you have set up one or more named users, then you must explicitly give them `r`-level permission to use these commands. For more information about user privileges, see “Setting Up LOM Privileges for Named Users” on page 54.

▼ To Power On the Server or to Power Down to Standby Mode

- To power on the server, type:

```
lom> poweron
```

- To power the server down to standby mode, type:

```
lom> poweroff
```

▼ To Display the lom> Prompt

- To display the lom> prompt, type the following LOM escape sequence:

```
# #.
```

When you type the LOM escape sequence, the LOM device takes control of the Serial A/LOM port and the lom> prompt appears on your terminal screen. You can type the LOM escape sequence at any time.

Note – If you are at the console and you type the first character of the LOM escape sequence (by default this is #), there is a delay of one second before the character appears on the screen. This is because the server waits to see if you type the dot (.) character next. If you do, the lom> prompt is displayed. If you do not, the # character appears on the screen.

For information about changing the first character of the LOM escape sequence, see “To Change the First Character of the Sequence for Escaping to the lom> Prompt (lom -X)” on page 77.

▼ To Exit From the lom> Prompt

- To return to the Solaris console prompt from the lom> prompt, type:

```
lom> console
```

Note – If you have the Serial A/LOM port dedicated to the LOM device (instead of shared between the LOM and the console), this command will have no effect. For information about dedicating the Serial A/LOM port to the LOM device, see “Separating LOM From the Console on the Serial A/LOM Port” on page 60.

Note – If you have set up named users of the LOM device, the users need c-level permission to use the console command. Without it, the command will not work. For more information about setting up user permissions, see “Setting Up LOM Privileges for Named Users” on page 54.

▼ To Reset the Server

- To reset the server, type:

```
lom> reset
```

- To perform a limited reset affecting the processor only, type:

```
lom> reset -x
```

The `-x` option generates the equivalent of an externally initiated reset (XIR) of the server. You must have `r`-level permission to use this command. (For information about user authorization levels, see “Setting Up LOM Privileges for Named Users” on page 54.) The `-x` option takes the server into OpenBoot™ PROM mode and causes it to display the `ok` prompt. It is useful for driver or kernel debugging, because most of the contents of the server’s memory and registers are preserved. The server does not automatically return to the Solaris environment when you reset it using the `-x` option. Instead, you must reboot it from the `ok` prompt.

▼ To Display the `ok` or `kadb` Prompt

To display the `ok` or `kadb` prompt, type the following at the `lom>` prompt:

```
lom> break
```

Note – If the Serial A/LOM port is dedicated to the LOM device, this command will have no effect. For information about dedicating the Serial A/LOM port to the LOM device, see “Separating LOM From the Console on the Serial A/LOM Port” on page 60. To use the `break` command, you must have `c`-level LOM user privileges. For more information, see “Setting Up LOM Privileges for Named Users” on page 54.

Controlling the Server’s Booting Behavior

The LOM shell includes a `bootmode` command:

```
bootmode [-u][normal|forth|reset_nvram|diag|skip_diag]
```

This command enables you to dictate the behavior of the server after a reset. Its functionality is identical to that available on Sun keyboards with the Stop key combinations. (However, the `bootmode` command is provided because the Stop key combinations are not available for the Sun Fire V100 server: you cannot use them from a keyboard that is connected to the server with a serial link.)

You must have `r`-level LOM permission to use the `bootmode` command. For information about user privileges, see “Setting Up LOM Privileges for Named Users” on page 54.

Boot Modes Available

If you use the `bootmode` command without arguments, the LOM device reports only the current boot mode. The boot modes available are listed in TABLE 5-1.

TABLE 5-1 Boot Modes

| Mode | Description |
|---------------------|--|
| <code>-u</code> | This option does not represent a boot mode. However, if you have previously dedicated the Serial A/LOM port to LOM and you now want to share the port between the console and LOM, you can use the <code>-u</code> option. It is a quick alternative to the procedure described for sharing the Serial A/LOM port in the section “Separating LOM From the Console on the Serial A/LOM Port” on page 60. |
| <code>normal</code> | In this mode, the server boots using your OpenBoot PROM settings. To cause this parameter to take effect, you must reset the server after using the <code>bootmode</code> command at the <code>lom></code> prompt. |
| <code>forth</code> | In this mode, the server does not boot to the Solaris environment but stops the boot cycle at the <code>ok</code> prompt. The command is equivalent to the Stop-F key combination for Sun keyboards. To cause the parameter to take effect, you must use the <code>bootmode forth</code> command at the <code>lom></code> prompt and then reset the server. (It is only when the server resets that it reads the new <code>forth</code> parameter from the LOM device.) |

TABLE 5-1 Boot Modes

| Mode | Description |
|--------------------------|---|
| <code>reset_nvram</code> | In this mode, the server returns all NVRAM data to its default setting. The command is equivalent to the Stop-N key combination for Sun keyboards. To cause the parameter to take effect, you must reset the server after using the <code>bootmode</code> command at the <code>lom></code> prompt. |
| <code>diag</code> | In this mode, the server performs full self-diagnostics as part of the boot process. The command is equivalent to the Stop-D key combination for Sun keyboards. To cause the parameter to take effect, you must power off and then power on the server within 10 minutes of using the <code>bootmode</code> command at the <code>lom></code> prompt. |
| <code>skip_diag</code> | In this mode, the server skips the diagnostics part of the boot process. To cause the parameter to take effect, you must power off and then power on the server within 10 minutes of using the <code>bootmode</code> command at the <code>lom></code> prompt. |

Monitoring the Server From the LOM Shell

This section describes commands that enable you to check the status of the server and the components monitored by the LOM device.

It also describes how to view the events stored in the LOM device's event log.

▼ To Check How Long the Server Has Been Running

- To find out how much time has elapsed since the last boot, type:

```
lom> date
Time since last boot: +8d+20h48m2s
```

or:

```
lom> showdate
Time since last boot: +8d+21h49m6s
```

▼ To Check the Current Status of All Components

- To see the current status of all the components monitored by the LOM device, type:

```
lom> environment
```

CODE EXAMPLE 5-1 shows sample output from the `environment` command. In this example, all the components are running normally and none are faulty.

CODE EXAMPLE 5-1 Sample Output From the `environment` Command

```
lom>environment
Fault OFF
Alarm 1 OFF
Alarm 2 OFF
Alarm 3 OFF

Fans:
1 OK speed 99%
2 OK speed 95%

PSUs:
1 OK

Temperature sensors:
1 28degC OK
```

```
Overheat sensors:
```

```
1 OK
```

```
Supply rails:
```

```
1 OK
```

```
2 OK
```

```
3 OK
```

```
4 OK
```

```
5 OK
```

```
lom>
```

Viewing the LOM Event Log

The `eventlog` command reports the last 10 events. The `loghistory` command can report up to several hundred events. Note that the first event is the oldest and that each event has a time stamp indicating the hours and minutes (and, if applicable, days) since the following:

- The LOM device was last powered off (that is, since all power to the server, including standby power, was last removed) or
- If the server has been booted since all power was last removed, then the time stamp indicates the number of days, hours, and minutes since the last reboot.

▼ To View the Last 10 Events in the Event Log

- **Type:**

```
lom> show eventlog
```

▼ To View the Entire Event Log

- **Type:**

```
lom> loghistory [pause x] [level y]
```

where x is the number of lines you want to display before pausing, and y is the severity level of the events you want to see. By default, the `loghistory` command displays all the events in the log and does not pause the display.

If you specify a severity level, you will see reports for the level you specify and above. For example, if you specify level 2, you will see reports of level 2 and level 1 events. If you specify level 3, you will see reports of level 3, level 2, and level 1 events.

If you do not specify a level, you will see events for all levels.

For more information about severity levels, see “Viewing Event Reports That LOM Sends to syslogd” on page 61.

Each entry in the log includes the time of the event, the server’s host name, a unique identifier for the event, and a user-friendly text message describing the event.

Note – The LOM device’s Event Log is never cleared, and it can contain several hundred entries. Events are stored from the very first time the server boots. Eventually the buffer might become full, but when this happens, the LOM device will start again at the beginning of the buffer, overwriting the earliest events.

▼ To View All Events From the First to the n th Event Logged

- **Type:**

```
lom> loghistory index +n [pause x] [level y]
```

where n is the number of events you want to see that have been logged since the first event in the current log, x is the number of lines you want to display before pausing, and y is the severity level of the events you want to see. By default, the `loghistory` command does not pause the display.

▼ To View All Events From the Last One Logged to the *n*th Event Before It

- **Type:**

```
lom> loghistory index -n [pause x] [level y]
```

where *n* is the number of events you want to see listed that were logged before the last event in the current log, *x* is the number of lines you want to display before pausing, and *y* is the severity level of the events you want to see. By default, the `loghistory` command does not pause the display.

- **To see the last five events, type:**

```
lom> loghistory index -5
+0h39m34s Alarm 1 ON
+0h39m40s Alarm 3 ON
+0h39m54s Alarm 3 OFF
+0h40m0s Alarm 1 OFF
+0h40m58s Fault LED ON
```

Verifying That a Component Has Been Fixed

If a monitored component has failed, the LOM device does not continue to report the failure. You can, however, check the status of a component, for example, after attempting to fix it.

▼ To Check the Status of a Component

- **Type:**

```
lom> check
```

This causes the LOM device to update the status of all the components it monitors.

Setting Up LOM Privileges for Named Users

You can specify up to four named users of the LOM device on a Sun Fire V100 server. By default, no users are set up, and therefore no user login prompt appears when you use the LOM escape sequence.

However, if you set up one or more users, every time you use the LOM escape sequence to display the `lom>` prompt, you will be prompted for a user name and password. Therefore, one of the user accounts you set up must be for yourself.

Permissions Available for LOM Users

Four areas of authorization are available for named users. When you create a new user, no permissions are assigned until you use the `userperm` command. If you specify any permissions (using the `lom> userperm` command), only those that you specify will be available.

The four areas of authorization available are:

- **Console permission (c-level)**
This enables the named user to select the system console from the `lom>` prompt (if the Serial A/LOM port is shared between the LOM and the console). The `break` command also requires console permission.
- **User Administration permission (u-level)**
This enables the named user to add and delete users and alter their permissions.
- **Administration permission (a-level)**
This enables the named user to change the LOM device's configuration variables (see "Introduction to Lights-Out Management" on page 43).
- **Reset permission (r-level)**
This enables the user you have named to reset the server and to power it on and off using the LOM device.

For information about how to specify one or more of these areas of authorization for a named user, see "To Specify Permissions for a Named User" on page 57.

▼ To Create a LOM User Account

- **Type:**

```
lom> useradd username
```

where the *username* is up to eight characters long, begins with an alphabetic character, and contains at least one lowercase alphabetic character. You can use any of the following characters in the user name:

- Alphanumeric
- Period (.)
- Underscore (_)
- Hyphen (-)

Note – You must have User Administration (u-level) authorization to add a user (see “Permissions Available for LOM Users” on page 54). If you have not added any users, you have a-level and all other levels of authorization by default.

▼ To Specify the Password for a LOM User Account

- **Type:**

```
lom> userpassword username
```

where the *username* is the name of a LOM user account that already exists.

Note – You must have User Administration (u-level) authorization to set a password for a user (see “Permissions Available for LOM Users” on page 54).

▼ To View the Details of a LOM User Account

- **Type:**

```
lom> usershow
```

This command displays the details of all users.

Note – You must have User Administration (u-level) authorization to view the details of a LOM user account (see “Permissions Available for LOM Users” on page 54).

▼ To Change Your Own User Password

1. To change the password for the account you are currently logged into, type:

```
lom> password
```

2. When prompted, type the current password.
3. When prompted, type the new password you want to use.
4. Type the new password again to confirm it.

▼ To Delete a LOM User Account

- **Type:**

```
lom> userdel username
```

where the *username* is the name of an existing LOM user account.

Note – You must have User Administration (a-level) authorization to delete a user account (see “Permissions Available for LOM Users” on page 54).

If you delete all the users you have set up, you will no longer see the login prompt when you go to the lom> prompt.

By default, all four areas of authorization are available to each named user you set up. You can limit users to a particular area or areas of authorization by specifying permissions for a named user.

▼ To Specify Permissions for a Named User

- **Type:**

```
lom> userperm username [c][u][a][r][-]
```

You can specify:

- **All four parameters** (for example, `userperm cuar`)
This also makes all four areas available to the named user.
- **One, two, or three parameters**
This makes only the parameter or parameters you specify available.

The parameters are:

- **c**
This stands for “console permission”. It enables the named user to exit from the `lom>` prompt to the Solaris prompt (as long as the Serial A/LOM port is shared between LOM and the console).
- **u**
This stands for “user administration permission”. It enables the named user to add and delete users and alter their areas of authorization by using the `userperm` command.
- **a**
This stands for “administration permission”. It enables the named user to change the LOM device’s configuration variables (see “Setting the LOM Configurable Variables” on page 58).
- **r**
This stands for “reset permission”. It enables the user you have named to reset the server and to power it on and off using the LOM device.
- **-**
Use this character to specify that no permissions are assigned.

▼ To Quit a LOM Named User Session

- **Type:**

```
lom> logout
```

This returns you to the LOM login prompt.

Setting the LOM Configurable Variables

Note – To be able to run the commands described in this section, the named user must have a-level permission. For more information, see “Setting Up LOM Privileges for Named Users” on page 54.

▼ To Turn the Fault LED On and Off

- **To turn the Fault LED on by setting the `faulton` variable, type:**

```
lom> faulton
```

- **To turn the Fault LED off by setting the `faultoff` variable, type:**

```
lom> faultoff
```

▼ To Set an Alarm Flag

- **Turn the alarm on by typing:**

```
lom> alarmon n
```

where *n* is the number of the alarm you want to turn on: 1, 2, or 3.

- **Turn the alarm off by typing:**

```
lom> alarmoff n
```

where *n* is the number of the alarm you want to turn off: 1, 2, or 3.

Alarms 1, 2, and 3 are software flags. They are not associated with any specific conditions, but are available to be set by your own processes or from the command line. For more information, see “To Turn the Alarms On and Off (lom -A)” on page 76.

▼ To Stop LOM Sending Event Reports to the Serial A/LOM Port

- **Enable event reporting by typing:**

```
lom> event-reporting on
```

Note – This is the equivalent of using the `lom -E on` command from the Solaris shell. For more information, see “To View the Event Log (lom -e)” on page 72.

- **Disable event reporting by typing:**

```
lom> event-reporting off
```

Note – This is the equivalent of using the `lom -E off` command from the Solaris shell. For more details, see “To Stop LOM From Sending Reports to the Serial A/LOM Port (lom -E off)” on page 77.

Separating LOM From the Console on the Serial A/LOM Port

By default, the LOM device shares the Serial A/LOM port with the console, and when it has an event report to send, it takes control of the Serial A/LOM port itself, interrupting any console activity you are performing. To prevent the LOM device from interrupting the console, either turn serial event reporting off (see Chapter 6), or dedicate the Serial A/LOM port to the LOM device and use the Serial B port for console activity. The next section, “To Dedicate Serial A/LOM to LOM” on page 60, gives more detail.

The advantages of dedicating the Serial A/LOM port to the LOM device and using Serial B as your console port include:

- Preserving the ability to power on or reset the server (from the `lom>` prompt on Serial A/LOM) even if for any reason you lose access to Solaris on your console port (Serial B).
- Capturing all LOM events passively on a terminal connected to the dedicated LOM port (Serial A/LOM). Note, however, that if you dedicate the Serial A/LOM port to the LOM device, you cannot use the `console` command to quit the LOM shell. Instead, for access to the Solaris environment, you must connect to the server using the Serial B port.
- Preventing a user with console access from using the LOM escape sequence to exit the Solaris environment and access the LOM shell. If you dedicate the Serial B port to the console, users cannot bring up the LOM shell, which means that they cannot interrogate or reconfigure the LOM device.
- Performing binary data transfers. To perform any task other than an ASCII transfer, you must use the Serial B port.

▼ To Dedicate Serial A/LOM to LOM

1. Set up console connections to both the Serial A/LOM port and the Serial B port.
2. At the Solaris prompt, type:

```
# eeprom input-device=ttyb
# eeprom output-device=ttyb
# reboot
```

The Serial B port (ttyb) is now your console port. The Serial A/LOM port remains in the control of the LOM device.

▼ To Share the Serial A/LOM Port Between LOM and the Console

Note – By default, the Serial A/LOM port is shared by the LOM device and the console. Therefore, you should follow the instructions in this section only if you have configured the server by using the instructions in the previous section (“To Dedicate Serial A/LOM to LOM” on page 60) and you now want to share the Serial A/LOM port between LOM and the console.

1. Set up console connections to both the Serial A/LOM port and the Serial B port.
2. At the Solaris prompt, type:

```
# eeprom input-device=ttya
# eeprom output-device=ttya
# reboot
```

The Serial A/LOM port (ttya) is now shared between the LOM device and the console.

Viewing Event Reports That LOM Sends to syslogd

The LOM device monitors the status of the fans, supply rails, temperature, and power supply even when the server is powered off (the LOM device operates on standby power). If it detects a fault, it turns on the Fault LED on the server’s front and back panels and stores a report in an event log, which resides in memory on the LOM device. When the Solaris environment is running, the LOM device also sends event reports to `syslogd`. The `syslogd` handles these in the way it has been configured to handle event reports. This means that by default it sends them to the console and stores them in this directory:

```
/var/adm/messages
```

In this file, the reports are displayed with a label identifying them as `lom` reports and indicating their severity. Starting with the most severe, the levels of severity are:

1. Fatal

Fatal events can cause the server to shut itself down. Examples of fatal events are:

- Supply rail failures.
- Exceeded temperature thresholds.

2. Warning

Warning events do not cause the server to shut down, but they do require immediate attention. Examples of warning events are:

- Fans turning too slowly.
- Fault LED has been turned on.
- System Configuration Card has been removed.

3. Info

Info events are most likely to inform you that a problem is now fixed. For example, if you reinsert the System Configuration Card, the LOM device will generate an event to say that the System Configuration Card has been restored.

4. User

User level events indicate the activity of named users whom you have authorized to access the LOM device. For example, an event is generated when a user logs in or out.

LOM Shell Command List

The commands you can use from the `lom>` prompt are listed in TABLE 5-2.

TABLE 5-2 LOM Commands

| Command | Description |
|-------------------------|--|
| <code>alarmoff n</code> | Sets alarm <i>n</i> off, where <i>n</i> is 1, 2, or 3. These three alarms are software flags. They are associated with no specific conditions but are available to be set by your own processes. |
| <code>alarmon n</code> | Sets alarm <i>n</i> on. See the description for the <code>alarmoff</code> command. |
| <code>break</code> | Takes the server down to the <code>ok</code> prompt. |
| <code>bootmode</code> | Determines the behavior of the server during the boot process. |

TABLE 5-2 LOM Commands (*Continued*)

| Command | Description |
|----------------------------|---|
| <code>check</code> | Resets monitoring to report all failures. If a monitored component has failed, the LOM device will not continue to report the same failure. To check the status of the component, for example, after attempting to fix it, use the <code>check</code> command. This updates the status of all monitored components. |
| <code>console</code> | Takes you out of the LOM shell and back to the Solaris prompt. It returns control of the serial connection to the console. |
| <code>environment</code> | Displays the temperature of the server and the status of the fans, the power supply, the overtemperature monitors, the supply rails and circuit breakers, the alarms, and the fault LED. |
| <code>faulton</code> | Sets the Fault LED to On. |
| <code>faultoff</code> | Sets the Fault LED to Off. |
| <code>help</code> | Displays the list of LOM commands. |
| <code>loghistory</code> | Displays all the events in the LOM device's Event Log. |
| <code>logout</code> | Returns named users you have set up with password access to the LOM user login prompt. |
| <code>poweron</code> | Powers the server on. |
| <code>poweroff</code> | Powers the server down to standby power mode. |
| <code>reset</code> | Resets the server. |
| <code>show model</code> | Displays the server model. |
| <code>show hostname</code> | Displays the server name (this command is equivalent to the Solaris <code>uname -n</code> command). |
| <code>show eventlog</code> | Displays the LOM device's event log. The event log is the list of the last 10 events stored in the LOM device. The most recent event is the one at the bottom of the list. |
| <code>show escape</code> | Displays the current LOM escape sequence. |
| <code>show</code> | Displays all the information available with the <code>show</code> command. |
| <code>useradd</code> | Adds a user to the LOM device's list of permitted users. |
| <code>userdel</code> | Deletes a user from the LOM device's list of permitted users. |
| <code>usershow</code> | Displays the details of a named user's LOM account. |
| <code>userpassword</code> | Sets or changes a user's password. |
| <code>userperm</code> | Sets the permission levels for a named user. |
| <code>version</code> | Displays the version number of the LOM device. |

Managing the Sun Fire V100 Server From the Solaris Prompt

This chapter describes how to monitor and manage the Sun Fire V100 server with LOM-specific commands in the Solaris 8 operating environment. It contains the following sections:

- “Monitoring the System From the Solaris Prompt” on page 66
- “Configuring Automatic Server Restart” on page 73
- “Other LOM Tasks You Can Perform From the Solaris Prompt” on page 76

Note – For information about how to configure the LOM device driver, see Appendix A.

Monitoring the System From the Solaris Prompt

To use the Lights-Out Management (LOM) facilities either remotely or locally, you need a terminal connection to the Serial A/LOM port on the server (see “Setting Up a Console Connection to the Server” on page 20).

There are two ways to interrogate LOM or to send it commands to perform:

- Use LOM commands from the `lom>` shell prompt. For information about how to do this, see Chapter 5.
- Use LOM-specific Solaris commands from the Solaris prompt. These commands are described in this chapter.

All Solaris commands described in this section are available from the main Solaris `#` prompt. They run a utility called `/usr/sbin/lom`.

Where appropriate, the command lines given in this section are accompanied by typical output from the commands.

There are also manual pages for the LOM utility.

▼ To View the LOM Online Documentation

- To view the manual pages for the LOM utility, type:

```
# man lom
```

▼ To Check the Power Supply Unit (`lom -p`)

- To check whether the input lines and the output line for the power supply unit are working normally, type:

```
# lom -p
PSU:
1 OK
#
```

▼ To Check the Fan Status (`lom -f`)

- **Type:**

```
# lom -f
Fans:
1 OK speed 99%

#
```

Checking the Supply Rail Voltages and Internal Circuit Breakers (`lom -v`)

The supply rails are the Sun Fire V100 server's internal power lines. If the status of any of these is `faulty`, contact your local Sun sales representative. It means that you have either a faulty system board or a faulty PSU.

The `-v` option also displays the status of the server's internal circuit breakers. For any that have been tripped, the status will read `faulty`. The system contains three circuit breakers: one for each of the USB ports and one for the system configuration card reader.

If there is a problem with the circuit breakers or the USB port circuit breakers, remove the device connected to the relevant port and the circuit breakers will automatically recover.

If there is a problem with the circuit breaker for the system configuration card, it means either that the system configuration card is inserted incorrectly, or is broken. Insert a valid one to check.

▼ To Check the Status of the Supply Rails and Internal Circuit Breakers

- **Type:**

```
# lom -v
Supply voltages:
 1 5V status=ok
 2 3V3 status=ok
 3 +12V status=ok
 4 -12V status=ok
 5 VDD-CORE status=ok

System status flags (circuit breakers):
 1 USB0 status=ok
 2 USB1 status=ok
```

▼ To Check the Internal Temperature

- **Type:**

```
# lom -t
System Temperature Sensors:
 1 enclosure 25 degC : warning 67 degC : shutdown 72 degC

System Over-temperature Sensors:
 1 cpu status=ok
#
```

This checks the server's internal temperature, and the warning and shutdown threshold temperatures.

▼ To Check Whether the Fault LED and Alarms Are On or Off

- **Type:**

```
# lom -l
LOMlite alarm states:
Alarm1=off
Alarm2=off
Alarm3=off
Fault LED=on
#
```

Alarms 1, 2, and 3 are software flags. They are not associated with any specific conditions, but are available to be set by your own processes or from the command line. For more information, see “To Turn the Alarms On and Off (lom -A)” on page 76.

▼ To Change the LOM Automatic Server Restart Configuration (lom -w)

For full information about enabling and using LOM’s automatic server restart (ASR) process, see “To Configure the LOM ASR” on page 73.

- **To find out how the LOM watchdog is currently configured, type:**

```
# lom -w
LOMlite watchdog (ASR) settings:
Watchdog=on
Hardware reset=off
Timeout=40 s
#
```

The LOM watchdog is enabled by default when the Solaris environment boots. This means that, by default, if the watchdog does not receive a “pat” for 40,000 milliseconds, it will turn on the Fault LED on the front and back panels of the system, generate a LOM event report, and, if configured to do so, perform an automatic server restart. However, although the watchdog is enabled by default when Solaris boots, the `Hardware reset` option is not. This means that the LOM device does not, by default, automatically restart the server after a lockup.

- To configure the LOM device to perform an automatic server restart (ASR) after a lockup, you must enable the `Hardware reset` option as well as the `Watchdog` option.

For more information, see “Configuring Automatic Server Restart” on page 73.

▼ To View the Configuration of LOM

- To view the settings of all the configurable variables for the LOM device, type:

```
# lom -c
LOMlite configuration settings:
serial escape character=#
serial event reporting=default
Event reporting level=fatal, warning & information
Serial security=enabled
Disable watchdog on break=disabled
Automatic return to console=disabled
alarm3 mode=watchdog
firmware version=3.0
firmware checksum=2983
product revision=0.0
product ID=Sun Fire 100
#
```

▼ To View All the Status Data Stored by LOM, Plus Details of the Device’s Own Configuration

- Type:

```
# lom -a
```

Code example 6-1 gives sample output of this command.

CODE EXAMPLE 6-1 Sample `lom -a` output

```
PSUs:
1 OK

Fans:
```

CODE EXAMPLE 6-1 Sample lom -a output

```
PSUs:
1 OK speed 68%

LOMlite configuration settings:
serial escape character=#
serial event reporting=default
Event reporting level=fatal, warning & information
Serial security=enabled
Disable watchdog on break=enabled
Automatic return to console=disabled
alarm3 mode=user controlled
firmware version=3.9
firmware checksum=2262
product revision=0.1
product ID=Sun Fire 100

LOMlite Event Log:
+12d+18h28m30s  fault led state - ON
+12d+18h28m34s  fault led state - OFF
+12d+18h28m43s  fault led state - ON
+12d+18h28m45s  fault led state - OFF
+12d+18h28m46s  fault led state - ON
+12d+18h28m47s  fault led state - OFF
+12d+18h28m48s  fault led state - ON
+12d+18h28m49s  fault led state - OFF
4/11/2001 15:23:33 GMT LOM time reference
4/25/2001 15:30:13 GMT LOM time reference

LOMlite alarm states:
Alarm1=off
Alarm2=off
Alarm3=on
Fault LED=off

LOMlite watchdog (ASR) settings:
Watchdog=off
Hardware reset=off
Timeout=127 s

Supply voltages:
1          5V status=ok
2          3V3 status=ok
3          +12V status=ok
4          -12V status=ok
5          VDD core status=ok
```

CODE EXAMPLE 6-1 Sample `lom -a` output

```
PSUs:

System status flags (circuit breakers):
 1          USB0 status=ok
 2          USB1 status=ok
 3          SCC status=ok

System Temperature Sensors:
 1          Enclosure 27 degC : warning 67 degC : shutdown 72 degC
System Over-temperature Sensors:
 1 CPU status=ok

Console output prior to last reset:
```

▼ To View the Event Log (`lom -e`)

- To see the event log, type:

```
# lom -e n,[x]
```

where *n* is the number of reports (up to 128) that you want to see and *x* specifies the level of reporting you require. There are four levels of event reporting:

1. Fatal events
2. Warning events
3. Information events
4. User events

If you specify a level, you will see reports for that level and above. For example, if you specify level 2, you will see reports of level 2 and level 1 events. If you specify level 3, you will see reports of level 3, level 2, and level 1 events.

If you do not specify a level, you will see reports of level 3, level 2, and level 1 events.

FIGURE 6-1 shows a sample event log display. Note that the first event is the oldest and that each event has a date stamp indicating the days, hours and minutes since the system was last booted.

```
# lom -e 10
LOMlite Event Log:
+0h0m21s host reset
9/15/2000 17:35:28 GMT LOM time reference
+0h3m20s fault led state - ON
+0h3m24s fault led state - OFF
+0h39m34s Alarm 1 ON
+0h39m40s Alarm 3 ON
+0h39m54s Alarm 3 OFF
+0h40m0s Alarm 1 OFF
+0h48m52s fault led state - OFF
+0h49m39s Fan 1 FATAL FAULT: failed
+0h50m58s fault led state - ON

# lom -e 10
```

FIGURE 6-1 Sample LOM Device Event Log (Oldest Event Reported First)

Configuring Automatic Server Restart

You can configure automatic server restart (ASR) to restart a server automatically after a lockup. LOM has a watchdog process that, by default, expects to be patted every 10,000 milliseconds. If it does not receive a pat after 40,000 milliseconds (default), then LOM switches on the front and back fault LEDs and generates a LOM event report. However, it does not automatically restart the system unless you have configured it to do so.

▼ To Configure the LOM ASR

- Add the **-R** option to the `prioctl` command in the script file called `/etc/rc2.d/S25lom`.

This is the script that runs the LOM watchdog process:

```
# prioctl -e -c RT lom -W on,40000,10000 -R on
```

When you have done this, LOM will restart the server whenever the watchdog times out.

You can turn the option on and off from the Solaris command prompt. For more information, see “To Set the Hardware Reset Option From a Script or Command (`lom -R on`)” on page 75.

However, as long as you have the `-R on` option set in `/etc/rc2.d/S25lom`, the `Hardware Reset` option will always be enabled when you start the system.

Enabling the LOM Watchdog Process From Your Own Script or Command (`lom -W on`)

Note – You do not normally need to do this. If you want to configure LOM to perform an automatic server restart after a lockup, see “To Configure the LOM ASR” on page 73. Use the `lom -W on` option on the command line or in another script file only if you have removed the `/etc/rc2.d/S25lom` script.

By default, the LOM watchdog process is enabled, and if you type `lom -W on` while the watchdog process is already running, the command will have no effect. You can run this command only if you have removed the `/etc/rc2.d/S25lom` script file, or if you have turned the watchdog off manually by using the `lom -W off` command.

The default `priocntl` command is:

```
priocntl -e -c RT lom -W on,40000,10000
```

The number 40,000 on this command line indicates the watchdog’s timeout period in milliseconds; you can specify a different number. The number 10,000 indicates its pat interval in milliseconds; again, you can specify a different number.

Note – Do not specify a watchdog timeout period of less than 5000 milliseconds. If you do, the watchdog times out frequently even though the server has not locked up.

If the watchdog process times out (in other words, if it does not receive its expected pat), the LOM device will turn on the server’s front and back Fault LEDs and generate a LOM event report. However, it will not automatically reset the system. To make it reset the system, you must use the `-R` option. For more information, see “To Set the Hardware Reset Option From a Script or Command (`lom -R on`)” on page 75.

- If you have no LOM watchdog process running already and you want the process to run, type the following, or add it to another script file:

```
# lom -W on,40000,10000
```

- If you want the LOM device to perform an automatic server restart after a lockup, you must include the `-R on` option in the command, as follows:

```
# lom -W on,40000,10000 -R on
```

Note – Unless you include the `lom -W on` and `-R on` options in a script file, you must run the `lom` command every time you reboot the system if you want to use the automatic server restart facility. Otherwise the watchdog will not run, and the server will not reset after a lockup.

▼ To Set the Hardware Reset Option From a Script or Command (`lom -R on`)

To make the LOM device's watchdog process trigger an automatic server restart (ASR) after a lockup, add the `-R on` option to the command in your `/etc/rc2.d/S25lom` script file. This is the script that runs the watchdog. For instructions about how to do this, see "To Configure the LOM ASR" on page 73.

However, if for any reason you are not using the script file provided with your system (`/etc/rc2.d/S25lom`) but have instead enabled the watchdog from the command line or from another script file, you can turn the `Hardware reset` option on.

- To turn the `Hardware reset` option on, type the following at the command line:

```
# lom -R on
```

- To turn the `Hardware reset` option off from the command line, type:

```
# lom -R off
```

Other LOM Tasks You Can Perform From the Solaris Prompt

This section describes how to:

- Turn the alarms and Fault LEDs on and off with the `lom` command.
- Change the first character of the `lom` escape sequence.
- Stop LOM sending reports to the Serial A/LOM port.
- Remove driver protection from the device driver.
- Make the LOM interface backward compatible.
- Upgrade LOM firmware.

▼ To Turn the Alarms On and Off (`lom -A`)

There are three alarms associated with LOM. They are not associated with specific conditions but are software flags that can be set either by your own processes or from the command line.

- To turn an alarm on from the command line, type:

```
# lom -A on,n
```

where *n* is the number of the alarm you want to set: 1, 2, or 3.

- To turn the alarm off from the command line, type:

```
# lom -A off,n
```

where *n* is the number of the alarm you want to turn off: 1, 2, or 3.

▼ To Turn the Fault LED On and Off (`lom -F`)

- To turn the Fault LED on, type:

```
# lom -F on
```

- To turn the Fault LED off, type:

```
# lom -F off
```

▼ To Change the First Character of the Sequence for Escaping to the lom> Prompt (lom -X)

The character sequence #. (hash, dot) enables you to exit the Solaris prompt to the lom> prompt.

- To change the first character of this default lom escape sequence, type:

```
# lom -X x
```

where x is the alphanumeric character you want to use instead of #.

Note – If you are at the console and you type the first character of the LOM escape sequence (by default this is #), there is a delay of one second before the character appears on the screen. This is because the system waits to see if you type the dot (.) character next. If you do, the lom> prompt appears. If you do not, the # character appears. If you want to change the LOM escape character, use a character that is not included in any console commands; otherwise the delay between your striking the key and the character appearing on the screen may affect your typing at the console.

▼ To Stop LOM From Sending Reports to the Serial A/LOM Port (lom -E off)

LOM event reports can interfere with information you are attempting to send or receive on the Serial A/LOM port. By default, the Serial A/LOM port is shared by the console and LOM. LOM interrupts the console whenever it needs to send an event report. To prevent LOM from interrupting the console on Serial A/LOM, turn serial event reporting off.

- To stop LOM from sending reports to the Serial A/LOM port, type:

```
# lom -E off
```

- To turn serial event reporting on again, type:

```
# lom -E on
```

If you want to dedicate the Serial A/LOM port to the LOM device and you want to use the Serial B port as your console port, see “To Dedicate Serial A/LOM to LOM” on page 60.

▼ To Make the LOM Interface Backward Compatible (lom -B)

If you have scripts written to the LOMlite interface on the Netra T1 Model 100/105 server or the Netra t 1400/1405 server and you want to use these scripts on the Sun Fire V100 server, you can add file system links that make this possible.

- Type:

```
# lom -B
```

When you have done this, you will be able to use the old scripts on the new system.

▼ To Upgrade LOM Firmware (lom -G default)

To upgrade the firmware for LOM, obtain the new firmware package from the SunSolveSM website (<http://sunsolve.sun.com>) or from your local Sun sales representative, and type the following:

```
# lom -G default
```

Note – LOM firmware upgrades are released as patches and include detailed installation instructions.

PART **III** Maintenance and Troubleshooting

Interpreting the LEDs

This chapter describes the location and function of the warning LEDs on the server, and contains the following section:

- “Interpreting the Front- and Back-Panel LEDs” on page 82

Interpreting the Front- and Back-Panel LEDs

The Sun Fire V100 server contains two front panel LEDs (see FIGURE 7-1) and four rear panel LEDs (see FIGURE 7-2). Those on the front panel indicate power and faults only. Those on the back panel indicate the presence of up to two ethernet connections, and replicate the power and fault information of the front LEDs.

Front-Panel LEDs

The front panel LEDs are located at the top left of the servers front bezel.

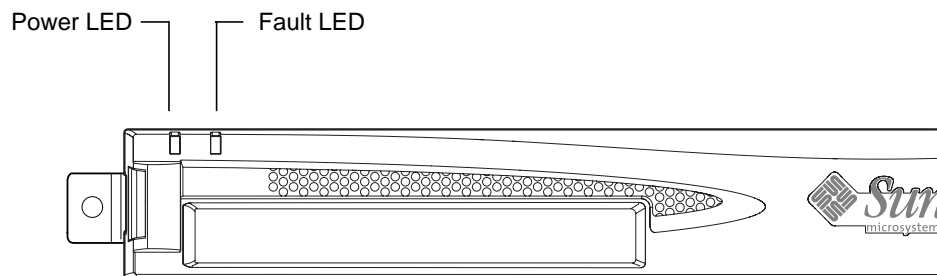

FIGURE 7-1 Front-Panel Power and Fault LEDs

- **Power LED (Green)**
This LED is lit when the server is powered on. It is unlit when the server is in standby mode.
- **Fault LED (Amber)**
The Fault LED is *constantly* on when a problem has occurred that is *not fatal* to the server, but that you should fix as soon as possible. Circumstances that can create this condition include the following:
 - The temperature inside the server's enclosure is higher than normal.
 - The voltage on one of the server's output supply rails is unusually high.
 - The system configuration card, containing the server's serial number, MAC address, and NVRAM settings, has been removed.

- The LOM watchdog has timed out, indicating that the server has locked up. You can configure the server to restart automatically after a lockup (see Chapter 6).

The Fault LED *flashes* when a problem has occurred *that is fatal* to the server. Circumstances that cause the Fault LED to flash include the following:

- The speed of the fan inside the server is too low.
- The temperature inside the server's enclosure is too high. By default, this causes the server to shut down. For information about configuring the server not to shut down in this condition, see Appendix B.
- The voltage on one of the server's output supply rails is too high. By default, this causes the server to shut down. For information about configuring the server not to shut down in this condition, see Appendix B.
- The temperature inside the CPU is too high. This causes the server to shut down.

Back-Panel LEDs

The four back panel LEDs convey the information listed below. For the location of the LEDs on the server, see FIGURE 7-2.

- **Ethernet port 0**
Lights to indicate link status with dmfe0.
- **Ethernet port 1**
Lights to indicate link status with dmfe1.
- **Fault LED**
This mirrors the Fault LED on the front panel.
- **Power LED**
This mirrors the Power LED on the front panel.

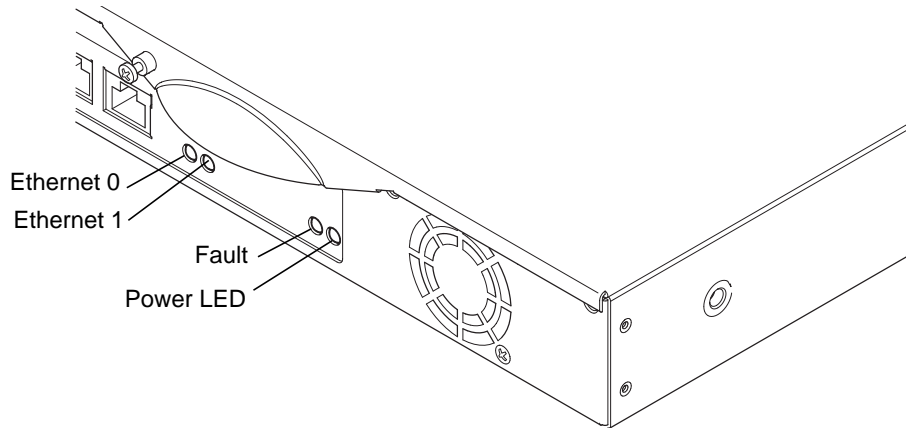

FIGURE 7-2 Back-Panel Power and Fault LEDs

▼ To Turn the Fault LED On or Off

- To turn the Fault LED on, type:

```
# lom -F on
```

- To turn the Fault LED off, type:

```
# lom -F off
```

For information about turning the Fault LEDs on and off from the LOM shell, see Chapter 5.

For more information about the `lom` commands included in the Solaris operating environment, see Chapter 6.

Removing and Replacing Components

This chapter details the procedures for moving the system configuration card from one server to another, and for changing replaceable components. It contains the following sections:

- “Adding Components or Replacing A Server” on page 86
- “Replacing the System Configuration Card” on page 86
- “Adding or Changing Internal Components” on page 87
- “Memory Installation and Removal” on page 91
- “Installing and Removing the Hard Disk Drive” on page 92

Adding Components or Replacing A Server

For a list of components that are available for the Sun Fire V100 server, see “Optional Components” on page 4. If there is a fault with any of the components listed below, replace the whole server. Should you need to do this, contact your Sun sales representative.

- Motherboard
- Processor
- Power Supply Unit
- Fan
- CD-ROM drive

The server contains a memory card called the system configuration card. The card contains the following data:

- the only copy of NVRAM
- IDPROM
 - host ID
 - MAC address

Replacing the System Configuration Card

The card is removable so that you can transfer the host ID and configuration data onto a new server, allowing quick and easy server replacement.

▼ To Swap the System Configuration Card (SCC) Between Servers

- 1. Make sure that both Sun Fire V100 servers are powered down.**
- 2. Remove the zip ties securing the system configuration cards in both servers, and remove the cards.**
- 3. Insert the system configuration card from the old server into the new one.**

4. Replace the zip tie on the new system.
5. Power on the new system (see Chapter 4).



Caution – Never remove the system configuration card when the server is booting or running Solaris. Power the server off or down to standby mode before removing or inserting the system configuration card.



Caution – Do not handle the system configuration card unless you need to transfer it to another system. If you need to handle it for this reason, avoid contact with the gold terminals on the underside of the card.

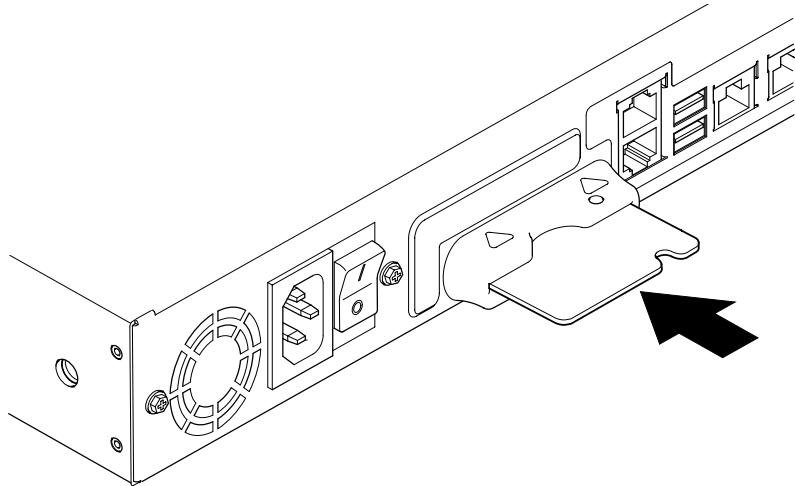

FIGURE 8-1 The System Configuration Card Slot

Adding or Changing Internal Components

The procedures in this section are for the attention of qualified service engineers only. If you need to replace or add a component, contact your local Sun sales representative, who will put you in touch with the Sun Enterprise Service branch for

your area. You can then arrange to return the system to Sun for repair under the terms of your warranty or you can order the components and have them installed by your own qualified service engineers.



Caution – The system contains electronic parts that are extremely sensitive to static electricity. Do not touch any metal parts. Place the system on top of an electrostatic discharge (ESD) pad (see FIGURE 8-2). Use the disposable antistatic wrist strap supplied with the system, and attach it to the metal base of the system before touching any of the internal components.



Caution – Before attempting to remove the cover, make sure that the server is powered off and that the power cord, and all other cables, have been disconnected from it.

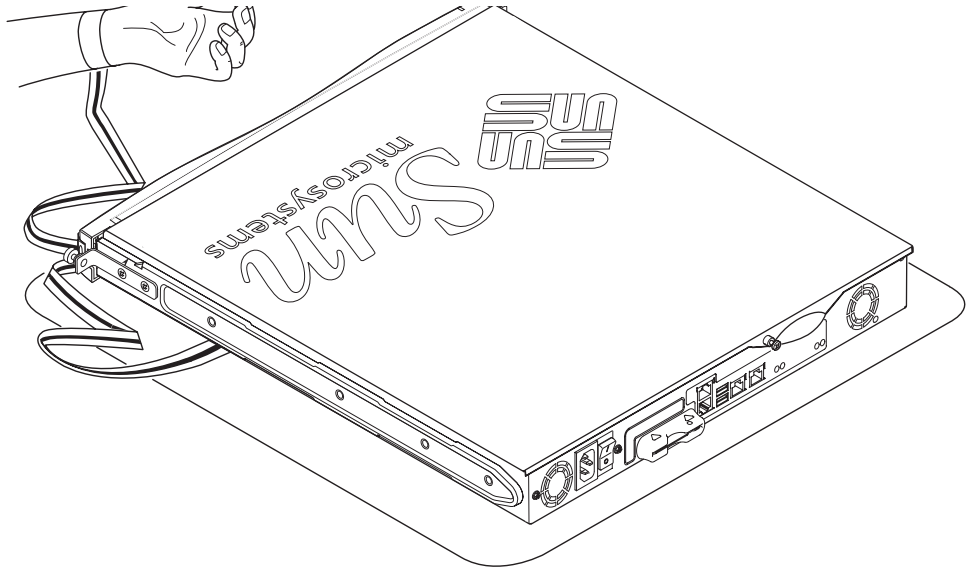

FIGURE 8-2 Using the Disposable Antistatic Wrist Strap Supplied With the System

▼ To Change Components In a Sun Fire V100 Server That Is In Use

If the system is currently in use and you need to open it to install a component:

1. **Shut down the Solaris environment from the console.**

2. Hold the On/Standby switch in the Standby position for more than four seconds to put the server in standby mode.
3. Disconnect the power cord.
4. Disconnect all other cables.
5. If the system is installed in a rack or cabinet, remove it.

▼ To Remove the Top Cover

- If the Sun Fire V100 server is not in use, go straight to step 1.
- If the server is already in use, see “To Change Components In a Sun Fire V100 Server That Is In Use” on page 88.

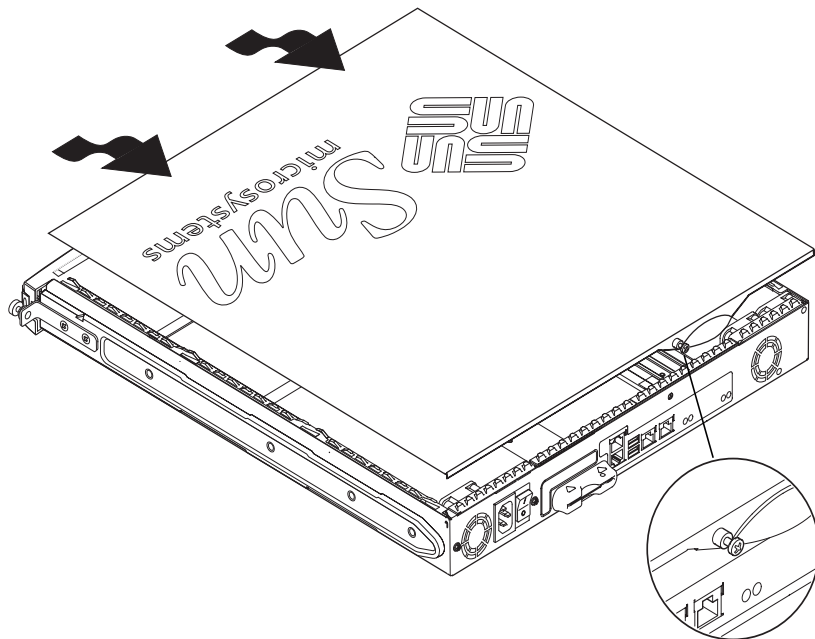

FIGURE 8-3 Removing the Top Cover

1. Place the unit on an ESD surface and attach an antistatic wrist strap (see FIGURE 8-2).
2. Unscrew the captive screw from the back of the unit (see FIGURE 8-3).

3. Slide the top cover back until the arrow on the cover lines up with the arrow on the server body.
4. Lift the cover up and off.

▼ To Replace the Top Cover

1. Align the arrow on the cover with the arrow on the server body.
2. Press the cover down so that it clips into the server body.

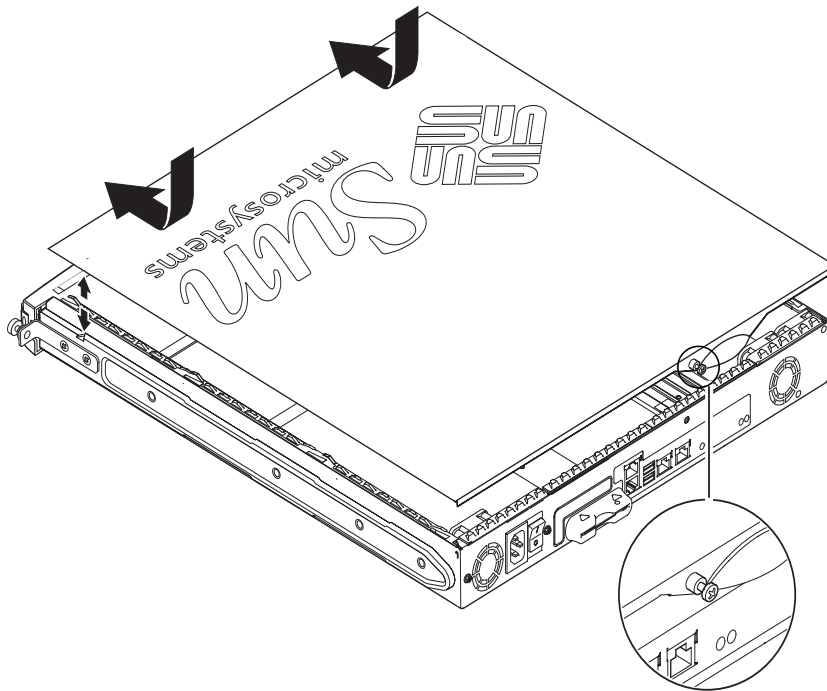

FIGURE 8-4 Replacing the Top Cover

3. Slide the cover forwards so that its leading edge is flush with the back of the server's front bezel.

Note – When the cover is in position, the arrows do not line up; the arrow on the cover is further towards the bezel than the arrow on the server body.

4. Tighten the captive screw on the back of the unit.

Memory Installation and Removal

There are four industry standard PC133 memory module sockets on the Sun Fire V100 server's system board. To see the location of the memory modules inside the server, see FIGURE 8-5 or the underside of the server's top cover.

▼ To Install and Remove Memory

- If the server is not in use, go straight to Step 1.
 - If the server is already in use, see "To Change Components In a Sun Fire V100 Server That Is In Use" on page 88.
1. Place the unit on an ESD surface and attach an antistatic wrist strap (see FIGURE 8-2)
 2. Remove the server's top cover (see "To Remove the Top Cover" on page 89).
 3. Insert the memory module in the next vacant DIMM socket.
The memory slots are numbered 3, 2, 1, 0. Add DIMMS in that order.

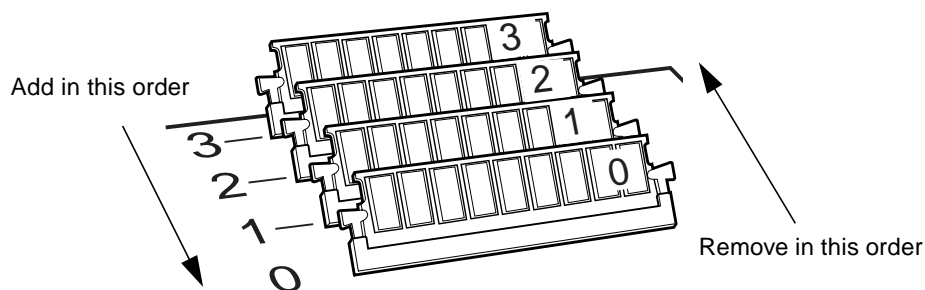

FIGURE 8-5 DIMM Insertion and Removal Sequence

4. Press the memory module until the latches at the sides of the socket click into place.

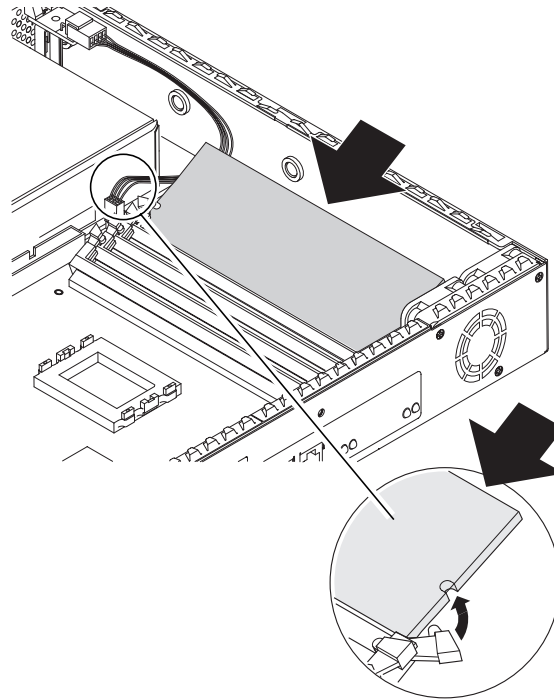

FIGURE 8-6 Installing Memory Into a Socket on the System Board

5. **If you are removing memory, open the latches and remove the module(s) in the order 0, 1, 2, 3.**
6. **Replace the system cover and tighten the captive screw (see FIGURE 8-4).**

Installing and Removing the Hard Disk Drive

The server can accept two hard disk drives, which are numbered 0 and 1.

▼ To Install a Hard Disk Drive

- If the Sun Fire V100 server is not in use, go straight to Step 1.

- If the server is already in use, see “To Change Components In a Sun Fire V100 Server That Is In Use” on page 88.
1. Place the unit on an ESD surface and attach an antistatic wrist strap (see FIGURE 8-2).
 2. Remove the server’s top cover (see “To Remove the Top Cover” on page 89).
 3. Remove the metal placeholder if your server has one (if it was configured with a single hard disk drive, the second hard disk drive slot will have the placeholder installed).

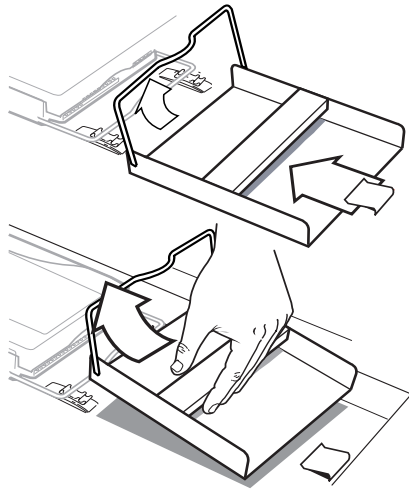

FIGURE 8-7 Removing the HDD Placeholder

4. Insert and align the new hard disk drive (see FIGURE 8-8).
 - a. Position HDD and slide onto the clips on the base of the server.
 - b. Press the handle into the two clips on the base of the server.

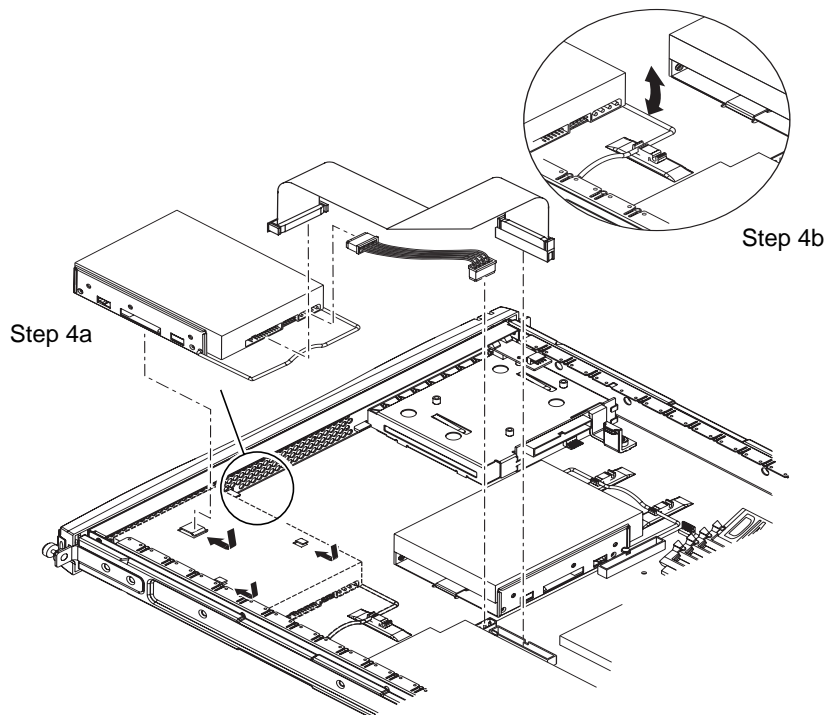

FIGURE 8-8 Installing a Hard Disk Drive

5. **Attach the power and data cables (see FIGURE 8-8).**
6. **Replace the system cover and tighten the captive screw (see FIGURE 8-4).**

▼ To Remove a Hard Disk Drive

- If the server is not in use, go straight to Step 1.
 - If the server is already in use, see “To Change Components In a Sun Fire V100 Server That Is In Use” on page 88.
1. **Place the unit on an ESD surface and attach an antistatic wrist strap (see FIGURE 8-2).**
 2. **Remove the server’s top cover (see “To Remove the Top Cover” on page 89).**
 3. **Disconnect the data and power cables.**

- 4. Unfasten the hard disk drive's handle from the two clips securing it.**
- 5. Slide the hard disk drive until it is free from the clips on the base of the server.**
- 6. Lift the hard disk drive up and out of the server.**

Reinstalling the Solaris Operating Environment

This chapter explains how to reinstall the Solaris operating environment onto the Sun Fire V100 server. It contains the following sections:

- “Reinstalling the Solaris Operating Environment” on page 98
- “Reinstalling the Lights-Out Management Software” on page 98

Reinstalling the Solaris Operating Environment

The Sun Fire V100 server is supplied with the Solaris operating environment preinstalled.

If for any reason you decide to reinstall the Solaris operating environment (for example, if you need to repartition your root disk or recover from a failure) follow the instructions in the *Solaris Installation Guide* (806-0955-10) and the *Solaris Advanced Installation Guide* (806-0957-10).

Reinstalling the Lights-Out Management Software

If you reinstall the Solaris operating environment and you intend to use the Lights-Out Management (LOM) facilities, you must re-install the Lights-Out Management software from the CD entitled *Software Supplement for the Solaris Operating Environment*. This CD is included among the CDs supplied with Solaris.

If you do not reinstall the LOM software as described here, the LOM facilities will not be available and layered applications that are dependent on them (for example, the Sun Management Center software) will not function correctly. To reinstall LOM, refer to the *Sun Hardware Platform Guide*.

Troubleshooting

This chapter describes the diagnostic tools you can use with the Sun Fire V100 server, lists some of the problems you might encounter when setting up or using a server, and gives information to help fix those problems. The information is contained in the following sections:

- “Diagnostic Tools” on page 100
- “Problems You Might Encounter” on page 105
- “Frequently Asked Questions” on page 108

Diagnostic Tools

The following troubleshooting tools are available for the servers:

- Power On Self Test (POST) Diagnostics
- OpenBoot Diagnostics (OBDiag)
- SunVTS

POST Diagnostics

To view Power On Self Test (POST) diagnostic and error messages you need to have a serial connection set up to the server. For more information, see “Setting Up a Console Connection to the Server” on page 20.

If the OpenBoot PROM (OBP) variable `diag-switch?` is set to `true`, then POST diagnostics will run automatically when you power on the server. However, the default setting for `diag-switch?` is `false`.

To initialize POST diagnostics, you need to set the `diag-switch?` variable to `true` and `diag-level` to `max` or `min`, and then power cycle the server. From the `ok` prompt:

1. Type:

```
ok setenv diag-switch? true
```

2. Type:

```
ok reset-all
```

The system will now run POST diagnostics and display status and error messages in your console window. If POST detects an error, it displays an error message describing the failure. A sample error message is shown below:

```
Power On Self Test Failed. Cause: DIMM U0702 or System Board
```

OpenBoot Diagnostics

Like POST diagnostics, OpenBoot Diagnostics can be run if the `diag-switch?` variable is set to `true`.

You can also run OpenBoot Diagnostics interactively and select which tests you want it to perform. To do so, follow the steps below from the `ok` prompt.

1. Type:

```
ok setenv diag-switch? true
ok setenv auto-boot? false
ok reset-all
```

2. Type:

```
ok obdiag
```

This displays the OpenBoot Diagnostics menu:

```
                                obdiag
1 SUNW,lomh@0,8010      2 ethernet@5          3 ethernet@c
4 i2c-nvram@0,a0      5 ide@d              6 pmu@3
7 serial@0,2e8        8 serial@0,3f8       9 usb@a
Commands: test test-all except help what printenvs setenv versions
exit
```

FIGURE 10-1 The `obdiag` Menu

The tests are described in TABLE 10-1. Note the number that corresponds to the test you want to perform, and use it with the `test` command. For example, to run a test on the primary Ethernet port, type:

```
obdiag> test 3
Hit the spacebar to interrupt testing
Testing /pci@1f,0/ethernet@c .....passed

Hit any key to return to the main menu.
```

3. When you have finished testing, exit OpenBoot Diagnostics and restore the value of `auto-boot?` to `true`.

To do this, type:

```
obdiag> exit
ok setenv auto-boot? true
ok auto-boot? true
ok boot
```

The function of each test is shown below.

TABLE 10-1 Open Boot Diagnostics Tests

| | | |
|---|-------------------------------|---|
| 1 | <code>SUNW,lomh@0,8010</code> | tests the LOM device |
| 2 | <code>ethernet@5</code> | tests the secondary Ethernet port |
| 3 | <code>ethernet@c</code> | tests the primary Ethernet port |
| 4 | <code>i2c-nvram@0,a0</code> | tests the SCC card |
| 5 | <code>ide@d</code> | tests the ide controller |
| 6 | <code>pmu@3</code> | tests the circuitry on the main CPU board |
| 7 | <code>serial@0,2e8</code> | test the ttyb port (Serial B) |
| 8 | <code>serial@0,3f8</code> | tests the ttya port (Serial A) |
| 9 | <code>usb@a</code> | tests the usb ports |

Setting the Diagnostic Level for POST and OpenBoot Diagnostics

There are three levels of diagnostic testing available for OpenBoot Diagnostics and POST diagnostics:

- *max* (maximum level)
- *min* (minimum level)
- *off* (no testing)

Set the testing level by using the OpenBoot PROM variable called `diag-level`. The default setting for `diag-level` is `min`. The test level is set from the `ok` prompt. To set the test level:

- **Type:**

```
ok setenv diag-level value
```

SunVTS

SunVTS, the Sun Validation and Test Suite, is an online diagnostics tool which you can use to verify the configuration and functionality of hardware controllers, devices and platforms. It runs in the Solaris 8 operating environment using any of the following:

- command line interface
- serial (tty) interface
- graphical interface within a windowed desktop environment.

SunVTS software lets you view and control a testing session on a remotely connected server. Below is a list of example tests:

TABLE 10-2 SunVTS Tests

| SunVTS Test | Description |
|-------------|---|
| disktest | Verifies local disk drives |
| fputest | Checks the floating-point unit |
| nettest | Checks the networking hardware on the system CPU board and on network adapters contained in the system. |
| pmem | Tests the physical memory (read only) |
| sutest | Tests the server's on-board serial ports |
| vmem | Tests the virtual memory (a combination of the swap partition and the physical memory) |

To Find Out If SunVTS is Installed

To check whether SunVTS is installed:

- **Type:**

```
# pkginfo -l SUNWvts
```

- If SunVTS software is loaded, information about the package will be displayed.

- If SunVTS software is not loaded, you will see the following error message:

```
ERROR: information for "SUNWvts" was not found
```

Installing SunVTS

By default, SunVTS is not installed on the Sun Fire V100 server. SunVTS is distributed via the *Software Supplement for the Solaris Operating Environment* CD. See the *Sun Hardware Platform Guide* for details. The default directory to use when you install SunVTS software is `/opt/SUNWvts`.

Using SunVTS Software

To test a Sun Fire V100 server by running a SunVTS session from a workstation using the SunVTS graphical user interface, follow the procedure below.

1. Use the `xhost` command to give the remote server access to the local display.
Type:

```
# /usr/openwin/bin/xhost + remote_hostname
```

2. Remotely log in to the server as superuser or root.

3. Type:

```
# cd /opt/SUNWvts/bin  
# ./sunvts -display local_hostname:0
```

Where `local_hostname` is the name of the workstation you are using.

Note – The directory `/opt/SUNWvts/bin` is the default directory for SunVTS software. If you have the software installed in a different directory, use that path instead.

When you start SunVTS software, the SunVTS kernel probes the test system devices and displays the results on the Test Selection panel. There is an associated SunVTS test for each hardware device on your system.

You can fine-tune your testing session by selecting the appropriate check boxes for each of the tests you want to run.

Problems You Might Encounter

This section outlines some particular problems you might encounter when setting up and using the Sun Fire V100 server and, where applicable, tells you where to look in the *Sun Fire V100 Server User's Guide* for more information.

Power On Failure

If the system does not power on when you apply power to the server, ensure that the power cord is properly connected to the system and to the wall receptacle. Verify that the wall receptacle is supplying AC power to the system.

If the wall receptacle AC power has been verified, but the system does not power on, the system power supply might be defective.

Cannot Set Up a Console Connection to a Server

The serial port pinouts are listed in "Setting Up a Console Connection to the Server" on page 20. Verify that they are correct for the device (that is, the terminal or terminal server) that you are connecting to the server.

No LOM Messages Displayed at the Terminal

You will only see LOM messages displayed at your terminal if you are connected to the server using the A LOM port. If you are connected through the Serial B port, then you need to switch serial ports to see LOM messages displayed.

Cannot Display the `lom>` Prompt Using the `#.` Escape Sequence

Check whether the first character of the `#.` escape sequence has been changed (this is a user-configurable value). To check the current value, type the following from the Solaris prompt:

```
# lom -c
```

The information that this command displays includes the serial escape character. If this is not “#”, then type the character that is currently specified and follow it immediately with a dot.

Problems Connecting to the Server Using a Handheld Device

Having Sync Manager turned on causes problems when you try to establish a connection to the server from a handheld device: make sure that Sync Manager is turned off.

OpenBoot PROM Initialization Aborts and the Server Will Not Boot

If the message “NO IDPROM” is displayed when the operating system attempts to read the serial number and MAC address, the OpenBoot PROM initialization sequence aborts. This could be caused by either of the following:

- Incorrectly fitted system configuration card.
- No valid system configuration card.

The SCC contains the serial number, MAC address, and NVRAM settings for the Sun Fire V100 server. Check that the card is correctly inserted by pressing it firmly home. If the server still will not boot, you may need to replace the system configuration card. See your Sun sales representative.

IDE Controller Failure

The probe-IDE diagnostic transmits an inquiry command to internal and external IDE devices connected to the system's on-board IDE interface. If the IDE device is connected and active, the target address, unit number, device type, and manufacturer name are displayed. Initialize the probe-IDE diagnostic by typing the probe-ide command at the ok prompt. The following code example shows the probe-IDE diagnostic:

```
ok probe-ide
Device 0 ( Primary Master )
ATA Model: ST34342A
Device 1 ( Primary Slave )
ATA Model: ST34342A
ok
```

Jumper Settings

The default settings for the jumpers are shown below. Do not change these settings.

| Jumper Name | Jumper Setting |
|-------------|--------------------|
| JP1 | 1-2 |
| JP3 | Not used. |
| JP7 | 1-2, 5-6. |
| JP8 | Not used. |
| JP9 | 1-2 |
| JP13 | Jumper not fitted. |
| JP14 | Jumper not fitted. |
| JP15 | 1-2 |
| JP16 | Jumper not fitted. |
| JP18 | Jumper not fitted. |
| JP19 | Jumper not fitted. |

Frequently Asked Questions

What hardware configurations is the Sun Fire V100 available in?

The Sun Fire V100 server is available in the following configurations:

| Processor | RAM | Hard Disk Drive | Sun Part Number |
|-----------|-------------------|----------------------|-----------------|
| 500MHz | 128 MB | 1 * 40 GB (7200 rpm) | 600-7881-xx |
| 500MHz | 512 MB(2 * 256MB) | 1 * 40 GB (7200 rpm) | 600-7882-xx |
| 500MHz | 1 GB (4 * 256MB) | 2 * 40 GB (7200 rpm) | 600-7883-xx |
| 500MHz | 2 GB (4 * 512MB) | 2 * 40 GB (7200 rpm) | 600-7884-xx |

What software is preinstalled?

The Sun Fire V100 server comes preinstalled with the Solaris operating environment (64 bit) including LOM. For more information, see “Preinstalled Software” on page 3.

Can I install a 32-bit kernel?

The servers will only support a 64 bit kernel. Applications written for 32 bit or 64 bit environments, and which do not rely on 32 bit kernel drivers specifically, should work without modification.

Will my 32 bit application work on the Sun Fire V100 server?

32 bit applications should work without modification, as long as they were written to be dynamically linked. If not, they will not work with Solaris 8 (64 bit).

Where can I get more information on the Solaris operating environment?

All Solaris documentation is available online and can be downloaded in PDF format from <http://docs.sun.com>

What are the Sun Fire V100 server's expandability options?

The Sun Fire V100 server provides simplified expansion options. You cannot upgrade the CPU, and the server does not ship with PCI slots. Optional components and part numbers are listed in "Optional Components" on page 4.

Can I install my own PC DIMM memory?

Doing so risks breaking your warranty agreement. Only Sun service personnel should install memory and only Sun certified memory may be used.

What peripherals can I connect to the USB ports?

Currently, the Solaris 8 operating environment ships with minimal USB driver support and the only USB peripheral supported is the keyboard used with SunRay systems.

What information does the System Configuration Card hold?

The System Configuration Card contains:

- the only copy of NVRAM
- IDPROM
 - host ID
 - MAC address

Should I put a server into stand-by mode before removing a System Configuration Card?

Yes. The correct procedure for removing cards is described in "To Swap the System Configuration Card (SCC) Between Servers" on page 86.

What if a System Configuration Card is lost?

You can order a new card from your local Sun Customer Solution Centre.

Is there a DC version of the Sun Fire V100 server?

There are no plans to introduce a DC version of the Sun Fire V100 server.

How many Sun Fire V100 servers can be put in a standard 19-inch rack?

Physically and electrically, you can put up to 40 Sun Fire V100 servers into a standard 19-inch rack with two 20-amp circuits. However, a more practical deployment would be 32 servers in a rack with term servers, network gear, and additional power strips.

Where do I connect my monitor, keyboard, and mouse?

Because the Sun Fire V100 server has been designed as a rack-mount compute element, there is no keyboard, mouse or parallel port on the Sun Fire V100 server. To manage the server, you have to connect to the console (ttya) port and manage via a console connection. Two USB ports are available for adding a keyboard and/or mouse if needed.

What is ASR?

Automatic Server Restart (ASR) is a feature of Lights-Out Management that can automatically restart the Sun Fire V100 server in the event of the operating system locking up. The feature can be turned on or off and is fully configurable. See “Configuring Automatic Server Restart” on page 73 for more details.

Why are two Ethernet 10/100 ports included with the Sun Fire V100 server?

The most common deployment for a server in use at a service provider is to have two physical network connections to each server. One is for the production network, the other for the administrative or backup network. Each is a separate physical port, usually connecting to separate network switches. This provides better redundancy, in case of error, and increased isolation, for security.

Why does the server use RJ-45 instead of DB-9 or DB-25 connectors for the serial port?

The Sun Fire V100 server uses RJ-45 connectors for its serial ports because these connectors best suit service providers’ systems. With RJ-45 connectors, you can use standard Category 5 network cables without needing any extra adaptors. With DB-9 or DB-25 connectors, you would need to use extra adaptors to use the standard Category 5 network cable.

Do the serial ports support synchronous protocols?

No.

Will the server need a null-modem cable to connect to the console port?

No. Because the Sun Fire V100 server requires the use of console port, Sun has designed the server not to need a null-modem cable. All you need to connect a Sun Fire V100 server to a termserver is a standard Category 5 cable.

PART **IV** Appendixes

Physical and Environmental Specifications

In the following sections, this appendix gives the physical dimensions of the Sun Fire V100 server and describes the conditions in which the server is capable of operating:

- “Physical Specifications” on page 116
- “Environmental Specifications” on page 116
- “Operating Power Statistics” on page 117
- “Calculating Power Consumption” on page 118
- “Calculating Heat Dissipation” on page 118

Physical Specifications

TABLE A-1 Sun Fire V100 Server Physical Specifications

| Dimension | U.S. | Metric |
|-----------|--|----------|
| Height | 1.72 in. | 43.6 mm |
| Width | 17.2 in. | 436.7 mm |
| Depth | 18.8 in. | 478 mm |
| Weight | 9 kg (with two hard disk drives and four memory modules installed) | |

Environmental Specifications

You can operate and store the system safely in the conditions detailed below.

| Specifications | Operating | Storage |
|-----------------------|------------------------------------|------------------------------------|
| Ambient temperature | 5°C to 40°C 14°F to 104°F | -40°C to 70°C -8°F to 158°F |
| Temperature variation | 30°C/hr maximum 86°F/hr maximum | 30°C/hr maximum 86°F/hr maximum |
| Relative humidity | 5% to 85% (noncondensing) | 10% to 95% (noncondensing) |
| Altitude | -300m to +3000m | -300m to +12000m |

Acoustic Noise Generated

The system generates less than 60 dBA at a distance of 23.67 inches (600 mm) and a height of 59.17 inches (1500 mm) while operating in an ambient temperature of 77°F (25°C).

Environmental Compliance Information

- Electromagnetic compatibility
 - Immunity: The server conforms to EN55024.
 - Emissions: The server conforms to EN55022 Class A and FCC Class A.
- Safety
 - The system conforms to UL 1950 (3rd edition), EN60950

Operating Power Statistics

TABLE A-2 Operating Power Statistics

| | |
|--|---|
| Maximum operating current | 1.3A @ 100 VAC |
| Typical operating current | See "Calculating Power Consumption" on page 118 |
| Maximum in-rush current (cold start)* | 40A peak at 115V 25°C |
| Maximum in-rush current (warm start, or upon a restart 20 to 200 msec after power has been removed*) | 100A peak at 115V 25°C |
| Operating input voltage range | 90 to 264 Vrms |
| Voltage frequency range | 47 to 63 Hz |
| Power factor | 0.9 to 0.99 |
| Maximum volt-ampere rating | 130 VA |
| BTU/hr | 500 MHz processor: 148 (min), 280 (max). |

* The in-rush current decays to the normal operating current in less than 200 msec.



Caution – The power supply continues to regulate all outputs for at least 17 ms after AC power is removed.

Note – Logic ground and chassis ground are connected internally.

Note – Power from the standby output is available whenever input power is connected.

Calculating Power Consumption

A Sun Fire V100 server containing two disk drives has an estimated current requirement of approximately 1 amp.

TABLE A-3 shows the estimated power consumed by the individual components in a fully powered system. However, when you are calculating the power requirements for your system, you must allow for 63 percent PSU efficiency. To perform this calculation, add the figures for each component installed in the system, then divide the result by 0.63.

TABLE A-3 Estimated Power Consumption of Server Components

| Component | Sun Fire V100 |
|-------------------|---------------------------------|
| Base system | 22.5W |
| Memory (per DIMM) | 4.59 W (256 Mbytes, burst mode) |
| Hard disk drive | 6.5W (40 Gbyte/7200 rpm, idle) |

Note – To calculate the total power requirement for several servers installed in a single rack or cabinet, add the individual power requirement figure for each server installed.

Calculating Heat Dissipation

To calculate the heat generated by a server so that you can estimate the heat your cooling system must dissipate, convert the figure for the system's power requirement from watts to BTU/hr. A general formula for doing this is to multiply the figure for the power requirement by 3.415.

Configuring LOM Driver

This appendix describes the parameters that you can use to configure the LOM driver, and contains the following sections:

- “The LOM Device Driver and Script Files” on page 120
- “Configuring the LOM Device Driver” on page 121

The LOM Device Driver and Script Files

The LOM driver software included in the Solaris 8 (10/00) operating environment is as follows:

- `/platform/sun4u/kernel/drv/lom` (the lom driver [32-bit])
- `/platform/sun4u/kernel/drv/sparcv9/lom` (the lom driver [64-bit])
- `/platform/sun4u/kernel/drv/lom.conf` (the driver configuration file)

The driver is started by the following three scripts in the Solaris 8 (10/00) environment:

- `/etc/init.d/lom`
- `/etc/rc2.d/S25lom`
- `/etc/rc0.d/K80lom`

This appendix describes the driver parameters you can set in the `lom.conf` configuration file. Some of these parameters are configurable by means of the LOM-specific Solaris commands described in Chapter 6.

Configuring the LOM Device Driver

The full list of parameters you can set in this file is given in TABLE B-1.

TABLE B-1 LOM Configuration File Parameters

| Field | Format | Default | Effect |
|-----------------------------|--|---------|--|
| <code>wdog_reset=</code> | Boolean 0=FALSE 1=TRUE | 0 | Causes LOM to reset the server after a watchdog timeout. Setting this to 1 is equivalent to using the <code>lom -R on</code> command described in Chapter 6. |
| <code>wdog_alarm3=</code> | Boolean 0=FALSE 1=TRUE | 0 | Turns on software alarm 3 when the LOM watchdog times out. Setting this to 1 is equivalent to using the <code>lom -A on,3</code> command described in Chapter 6. |
| <code>serial_events=</code> | 0=OFF 1=ON 2=ON WHEN DRIVER NOT LOADED | 2 | Causes LOM to report events over the serial connection. Setting this parameter to 0 means that no events will be reported over the serial connection. Setting it to 1 means that events will be reported over the serial connection as well as to <code>syslogd</code> ; this is equivalent to <code>lom -E on</code> . If you have dedicated the Serial A/LOM port to LOM, you need to set this parameter to 1. It ensures that you receive all event reports at the terminal you have connected to Serial A/LOM. Finally, setting the parameter to 2 means that events will be reported over the serial connection but only when the driver is not running (when it is running they will be reported to <code>syslogd</code> , although Fatal and Warning messages will still go to Serial A/LOM). |

TABLE B-1 LOM Configuration File Parameters (Continued)

| Field | Format | Default | Effect |
|----------------------------|------------------------------|---------|--|
| disable_wdog_on_break= | Boolean 0=FALSE 1=TRUE | 1 | Causes LOM to disable its watchdog if it detects a break signal on the Serial A/LOM port. |
| disable_wdog_on_panic= | Boolean 0=FALSE 1=TRUE | 1 | Causes LOM to try to disable its watchdog after a system "panic". |
| faulty_voltage_shutdown= | Boolean 0=FALSE 1=TRUE | 1 | Causes LOM to attempt first to shut down the system and, if that fails, to power off the system in the event of a problem with the supply rails. |
| enclosure_warning_temp= | °C | 67 | Specifies the temperature at which LOM generates an overtemperature event. |
| over_temperature_shutdown= | Boolean 0=FALSE 1=TRUE | 1 | Causes LOM to attempt to shut down the system, or to power it off, if the enclosure temperature exceeds the level specified for the enclosure_shutdown_temp parameter. |
| enclosure_shutdown_temp= | °C | 72 | Specifies the enclosure temperature above which LOM attempts to shut the system down or, if this fails, to power the system off. (LOM will attempt to do either of these if over_temperature_shutdown is set to 1.) |
| serial_security= | Boolean 0=FALSE 1=TRUE | 1 | Enables and disables the user security facilities even if user security has been configured. You can use this parameter to set up users again if your users have forgotten their passwords. Cannot be turned on if no users are configured in the LOM. |

TABLE B-1 LOM Configuration File Parameters (*Continued*)

| Field | Format | Default | Effect |
|-------------------------------|------------------------------|---------|---|
| <code>serial_timeout=</code> | Multiples of 4 secs | 0 | Specifies the period after which LOM gives control of the Serial A/LOM port back to the console when it has finished sending a report (or when the user has issued a LOM shell command, if you have enabled the <code>serial_return=</code> option). By default, there is no delay at all. |
| <code>serial_return=</code> | Boolean 0=FALSE 1=TRUE | 0 | Causes LOM to return the user to the console from the <code>lom></code> prompt after each LOM shell command. You can use this option in conjunction with the <code>serial_timeout=</code> option. |
| <code>reporting_level=</code> | Number between 0 and 4 | 3 | Indicates the severity level down to which you want to see LOM event reports. 0 means no reports. 1 means fatal event reports only. 2 means fatal and warning event reports. 3 means fatal, warning and information event reports. 4 means fatal, warning, information and user event reports. (User event reports concern the user security facility; you will not see any unless you have enabled the security facility and set up users.) If power is removed then the setting is lost and not reinstated until the next Solaris boot. |

Each parameter must be on a separate line and must be followed by an equals sign (=) and a value, without spaces. Where the format is Boolean, 1 means true and 0 means false.

Index

A

- acoustic noise, 116
- alarms, setting, 62, 76
- altitude, 116
- anti-static wrist strap, 88
- automatic server restart, 73

B

- back panel LEDs, 82
- BTU rating, 117

C

- cables, 17
- Cisco L2511 Terminal Server, connecting, 25
- console connection
 - ASCII terminal, 24
 - setting up, 20
 - Sun workstation, 24
 - terminal server, 25
- cooling (heat dissipation), 118
- cross-over (null modem) cable, 22, 23
- current
 - in-rush, 117
 - operating, 117

D

- DB9 adapter, 23
- diagnostics, 100
 - OBDiag, 101

- POST, 100
- domain name, 36
- dumb terminal, serial connection, 23

E

- electro-magnetic compatibility, 117
- Ethernet
 - ports, 2
- event log, viewing, 51

F

- fans
 - checking the status, 67
- fault LED, 61, 82
 - turning on, 63
- flooring, 8
- Frequently Asked Questions, 108
- front panel LEDs, 82

H

- hard disk drive, 2
 - installing and removing, 92
 - power and data cables, 94
- heat dissipation, 118
- host name, 36
 - displaying, 63

I

- IDE controller failure, 107
- input voltage range, 117
- in-rush current, 117
- installation
 - quickstart, 5
 - rack mounting, 7
- internal circuit breakers, 67

L

- LEDs
 - back panel, 83
 - Ethernet port indicators, 83
 - fault indicator, 82
 - front panel, 82
 - power indicator, 82
- Lights Out Management (LOM)
 - commands, 62
 - displaying the host name, 63
 - displaying the version number of the LOM device, 63
 - monitoring the system, 66 to 72
 - online documentation, 66
 - parameters, 121
 - power supply unit, 66
 - powering up the system, 63
 - returning control of serial connection to console, 63
 - sample Event Log, 73
 - setting the alarms, 62, 76
 - setting up named users, 54 to 58
 - stopping event reporting, 121
 - turning the fault LED on, 63
 - updating component status, 62
 - viewing the LOM's Event Log, 51
- locating system components, 85
- log, viewing, 51
- LOMlite2 device
 - separating from the console on Serial A, 60
 - sharing Serial A between the console and the LOMlite2 device, 61
 - upgrading firmware, 78
 - version number, 63
- LOMlite2 interface
 - backwards compatibility, 78
 - escape sequence, 77

M

- memory
 - installing and removing, 91
 - part number, 4
- monitoring the system, *See* Lights-Out Management (LOM)

N

- Name Server, 36
- network install server
 - creating, 98
- null modem cable, 22, 23

O

- On/Standby switch, 39
- OpenBoot diagnostics, 101
- operating current, 117
- optional components, 4
- overview, 2

P

- physical specifications, 116
- pinout
 - serial port, 21, 25
- POST diagnostics, 100
- power
 - consumption, 118
 - factor, 117
 - requirements, 117, 118
 - switch, 39, 45
 - warnings, 18
- power LED, 82
- power supply
 - monitoring PSU and fans, 50
- power supply unit, 66
- powering on, 39
- problems
 - booting (OBP initialization aborts), 106
 - displaying the lom> prompt or the Solaris prompt, 106
 - getting to the LOM prompt, 106
 - turning serial event reporting on and off, 106

Q

quickstart, 5

R

remote reset, 47

removal

- hard disk drives, 92

- memory, 91

- system top cover, 93

replacing the server, 86

resetting remotely, 47

S

safety, 117

SCC (system configuration card), 86

security, 8

- LOMlite2 named user accounts, 54 to 58

Serial A/LOM port

- data subject to interruption by LOMlite2, 77

serial A/LOM port, 35, 37

- dedicating to the LOMlite2 device, 60

- stopping event reporting to, 77

- stopping event reports being sent to, 59

serial connection, 21, 35, 37

- returning control to console, 63

serial port, 2

- connection settings, 21

- DB-25 adapter, 22

- DB9 adapter, 23

- differences, 20

- pinout, 21, 25

shipkit, contents, 3

Solaris 8 operating environment

- preinstalled software, 3

- re-installing, 98

specifications, 2

standby power, 118

stopping event reporting, 77

Sun StorEdge

- 72-inch tall (19-inch wide) rack, 9 to 17

supply rail voltages, 67

system configuration card (SCC)

- swapping between servers, 86

T

temperature

- checking the system's temperature, 68

terminal server, 25

thermal issues, 8

tip session, 22

top cover

- removing, 89

- replacing, 90

V

voltage

- frequency range, 117

- input range, 117

volt-ampere rating, 117

W

watchdog timeouts, 121

wrist strap, 88

Free Manuals Download Website

<http://myh66.com>

<http://usermanuals.us>

<http://www.somanuals.com>

<http://www.4manuals.cc>

<http://www.manual-lib.com>

<http://www.404manual.com>

<http://www.luxmanual.com>

<http://aubethermostatmanual.com>

Golf course search by state

<http://golfingnear.com>

Email search by domain

<http://emailbydomain.com>

Auto manuals search

<http://auto.somanuals.com>

TV manuals search

<http://tv.somanuals.com>