

CC423

USER'S GUIDE

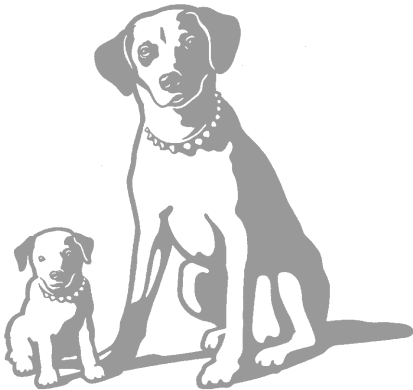

TRUST

CAMCORDER

Important Safety Information

Be sure to read all the safety information before you begin to use this product.

WARNING: To reduce the risk of fire or shock hazard, do not expose camcorder or AC adapter/charger to rain or moisture.

CAUTION

RISK OF ELECTRIC SHOCK
DO NOT OPEN



This symbol indicates "dangerous voltage" inside the product that presents a risk of electric shock or personal injury.

ATTENTION

RISQUE DE CHOC
ELECTRIQUE NE PAS OUVRIR



This symbol indicates important instructions accompanying the product.

TO REDUCE THE RISK OF ELECTRIC SHOCK, DO NOT REMOVE THE COVER (OR BACK). NO USER-SERVICEABLE PARTS ARE INSIDE. REFER SERVICING TO QUALIFIED SERVICE PERSONNEL.

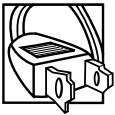

CAUTION: To prevent electric shock, match wide blade of plug to wide slot, fully insert.

ATTENTION: Pour éviter les chocs électriques, introduire la lame la plus large de la fiche dans la borne correspondante de la prise et pousser jusqu'au fond.

To reduce risk of injury, charge only rechargeable batteries recommended by the manufacturer for this camcorder. Other types of batteries may burst causing damage and personal injury.

CAUTION: Avoid operating your camcorder immediately after moving it from a cold location to a warm location. Give the camcorder 2 to 3 hours to reach a stable temperature before inserting a video cassette. When moved from a cold area to a warm location, moisture may condense on the head drum inside the machine. This moisture could cause the tape to stick to the headwheel and damage the headwheel or tape.

FCC Regulations state that unauthorized changes or modifications to this equipment may void the user's authority to operate it.

Product Registration

Please fill out the product registration card and return it immediately. Returning this card allows us to contact you if needed.

Keep your sales receipt for proof of purchase to obtain warranty parts and service and attach it here. Record the serial and model numbers located on the bottom of the camcorder.

Model CC423

Serial No: _____

Purchase Date: _____

Purchased From: _____

Assistance

We want to make sure you enjoy your new camcorder. If you have any questions, call:

Camcorder Exchange Warranty..... 800-283-6503 (Pages 66-67)

Customer Service..... 800-336-1900 (Page 65)

Accessories..... 800-338-0376 (Pages 52-59)

Table of Contents

Safety Information	i	Powering the Camcorder	
Product Registration	i	• Using the Adapter/Charger	10
Contents	1-2	• Using the Rechargeable Battery	
First-Time Operation		• Charging	11
• Assistance.....	3	• Attaching and Removing.....	12
• Unpack Camcorder and		• Care and Storage	13
Accessories	3	• Safety Precautions	13
• Attach the Adapter/Charger	4	• Battery Level Indicator.....	14
• Remove Lens Cap and Attach		• Using the Optional Car Cord	
to Handstrap.....	5	Adapter.....	15
• Turn on the Camcorder	5	Video Cassettes	
• Insert a Cassette	6	• Erase Protection.....	16
• Position Viewfinder and		• Recording and Playback Times.....	16
Adjust Eyepiece Focus Control	6	• Inserting and Removing	
• Start and Stop Recording	7	Cassettes.....	17
• Play Back What You Have		Cassette Care and Storage.....	17
Recorded	7	Traveling Tips	18
• Review the Camcorder's		Cassette Tips	18
Operating Controls	8-9		

(continued on next page)

Table of Contents

Recording Features

- Quick Review19
- Tape Positioning19
- Microphone19
- AI (Artificial Intelligence)19
- Program AE (Auto Exposure).....20
- Auto Focus20
- Macro Focus.....20
- Electronic Indexing21
- Time Remaining Display21
- Viewfinder22-23
- Displays in Viewfinder24-25
- Date and Time Display
 - Set the Date and Time26
 - Record the Date and Time
(or Date) on Your Tape27
 - Charging the Clock Cell27
- Zooming28
- Fading In and Out of Scenes29
- Tape Counter with Memory Stop.....30
- ProEdit® Features
 - Flying Erase Head31
 - Edit Search31
 - Audio Dubbing.....32-33
 - Audio/Video Dubbing.....34-35
 - Titler.....36-38

Recording Tips39

Recording on the Camcorder40-41

Playback

- Viewfinder Playback.....42
- Playback Features
 - Stop-Action Pause.....42-43
 - Picture Search42-43
 - Tracking43
- Playback on TV (or VCR) with
AUDIO/VIDEO IN Jacks44-45
- Playback on TV without
Audio and Video Inputs.....46-47

Color Enhancement Light.....48-49

Attaching the Shoulder Strap50

Packing the Carrying Case51

Optional Accessories.....52-59

- Accessory Order Form.....57-59

Care and Maintenance60-61

Trouble Checks62-64

Assistance.....65

Limited Warranty.....66-67

Specifications68

User Information.....69

Index (Alphabetical)70-73

First-Time Operation

This section describes only the basic steps necessary to set up your camcorder to record. Refer to the other sections for detailed operation and feature options.

Assistance

The toll-free numbers are available to help you with any problem you may encounter.

Camcorder Exchange Warranty800-283-6503

Customer Service800-336-1900

Accessories800-338-0376

1. Unpack the camcorder and accessories.

- Save the box and packing materials in case you ever need to store or ship your camcorder.
- The items shown below are packed with your camcorder. If any of them are missing or appear damaged, contact your dealer immediately.

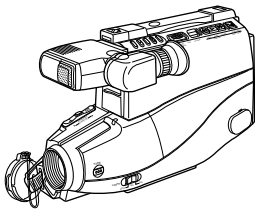

**Camcorder
Model CC423**



**Carrying Case
Part No. 221286**

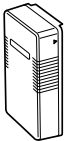

**WARNING: LEAD-ACID BATTERY.
MUST BE DISPOSED OF PROPERLY.**

**Rechargeable 10-Volt Battery
Stock No. EP096FS**



**Shoulder Strap
Stock No. 227327**

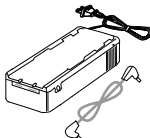

**AC Adapter/Charger:
Stock No. 221355 or 221356
DC Cable: Stock No. 209342**

Caution: Do not use this adapter/charger for any purpose other than charging the EP096FL or EP096FS battery pack or supplying power to the camcorder.

First-Time Operation

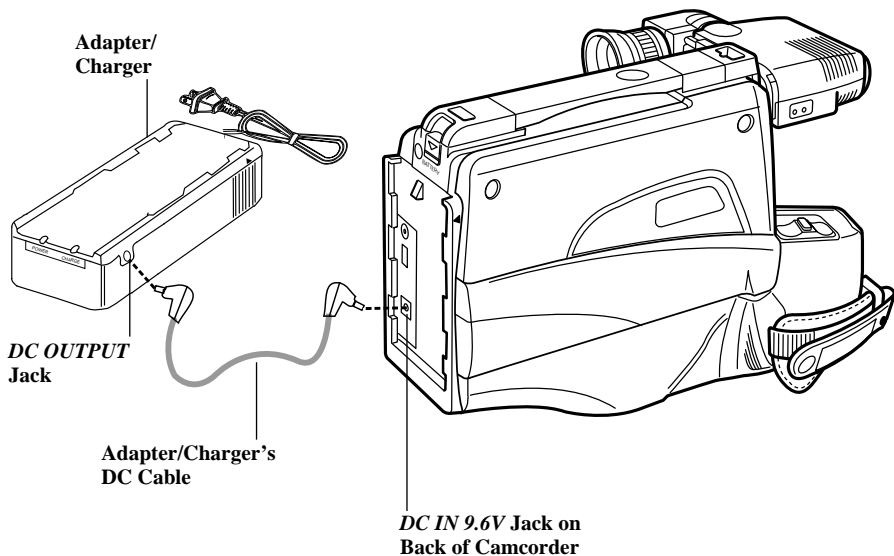

2. Attach the adapter/charger.

Since the battery must be charged before it can be used the first time, attach the adapter/charger to the camcorder.

- Attach one end of the adapter/charger's DC cable to the *DC OUTPUT* jack on the adapter/charger.
- Attach the other end of the cable to the *DC IN 9.6V* jack on the camcorder.
- Plug the adapter/charger's plug into an operating outlet.
- *Details are on page 10.*

First-Time Operation

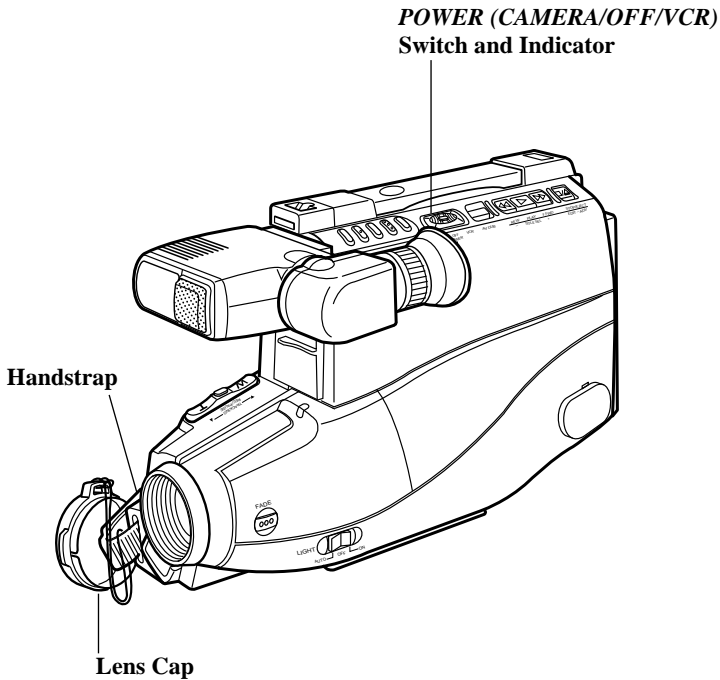

3. Remove the lens cap and attach it to the handstrap.

4. Turn on the camcorder.

The position of the *POWER* (*CAMERA/OFF/VCR*) switch tells the camcorder whether you want to record (*CAMERA*), play back tapes (*VCR*), or turn off the power (*OFF*).

- Press and hold the small button on *POWER* while sliding it in *CAMERA*. The *POWER* indicator will light when the camcorder is turned on.

(continued on next page)

First-Time Operation

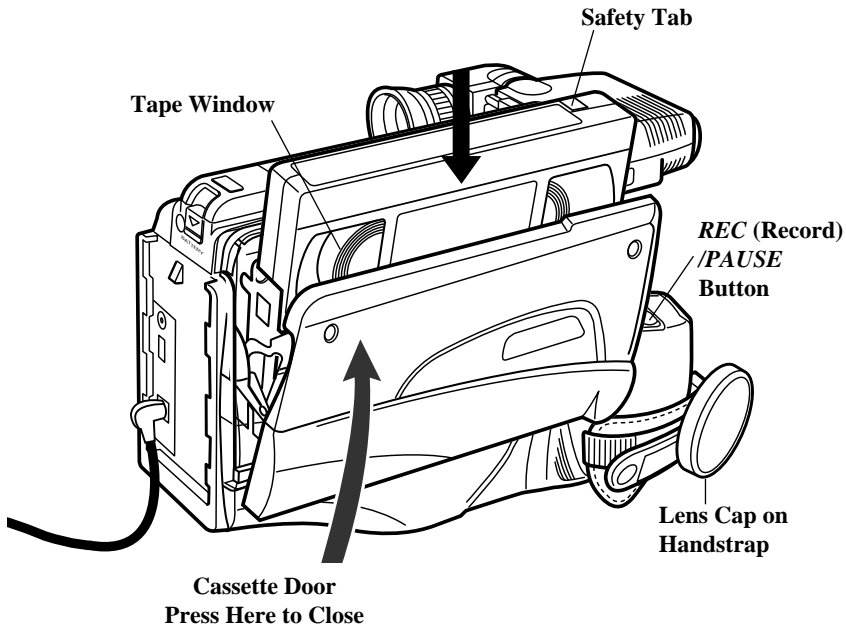

5. Insert a cassette.

- Press *STOP/EJECT* to open the cassette compartment.
- Insert the cassette with the safety tab facing up and the tape windows facing out.
- Press the cassette down gently until it locks into place, and close the cassette compartment door.
- *Details are on page 17.*

6. Position viewfinder and adjust eyepiece focus control.

- Grasp the viewfinder and rotate it horizontally.
- Pull the viewfinder out from the camcorder and rotate the eyepiece into a comfortable viewing position.
Caution: Pulling on the eyepiece may cause damage to the eyepiece or camcorder.
- If the image in the viewfinder is blurry, adjust the eyepiece focus control for your vision. *Details are on page 22.*

First-Time Operation

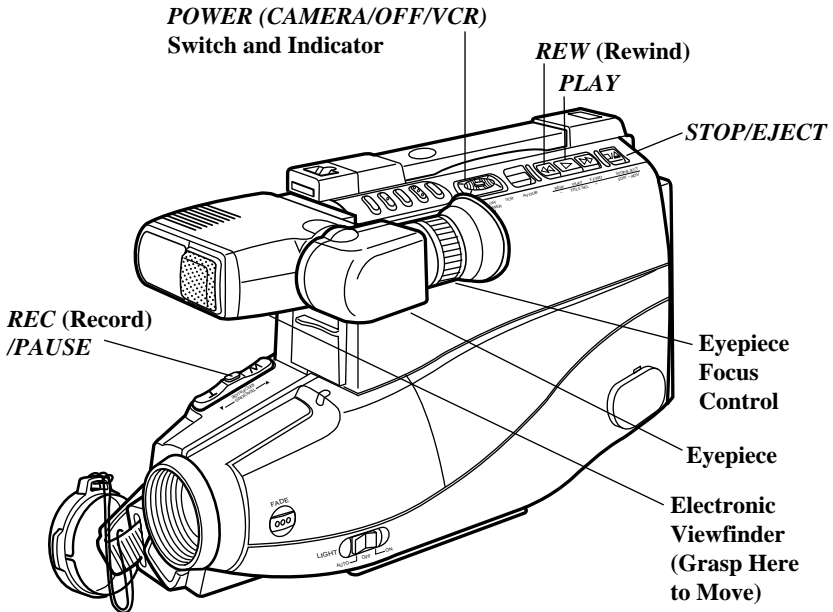

7. Start and stop recording.

Start and stop recording by pressing and releasing *REC/PAUSE*. *REC* appears in the viewfinder. You do not have to hold the button to record.

Notes: If you do not record within five minutes, the camcorder will automatically shut off to prevent excessive tape wear. Press *REC/PAUSE* to turn on the camcorder.

Any material recorded on the tape will automatically be erased if you record over it.

8. Play back what you have recorded.

- Press *REC/PAUSE* to stop recording.
- Press and hold the small button on *POWER* while sliding it in *VCR*.
- Press *REW* (rewind) to rewind the tape.
- Press *PLAY* to play back the tape in the viewfinder.
- Press *STOP/EJECT* when you are finished playing back the tape.
- *Details on viewfinder playback are on page 42.*

(continued on next page)

First-Time Operation

9. Review the camcorder's operating controls.

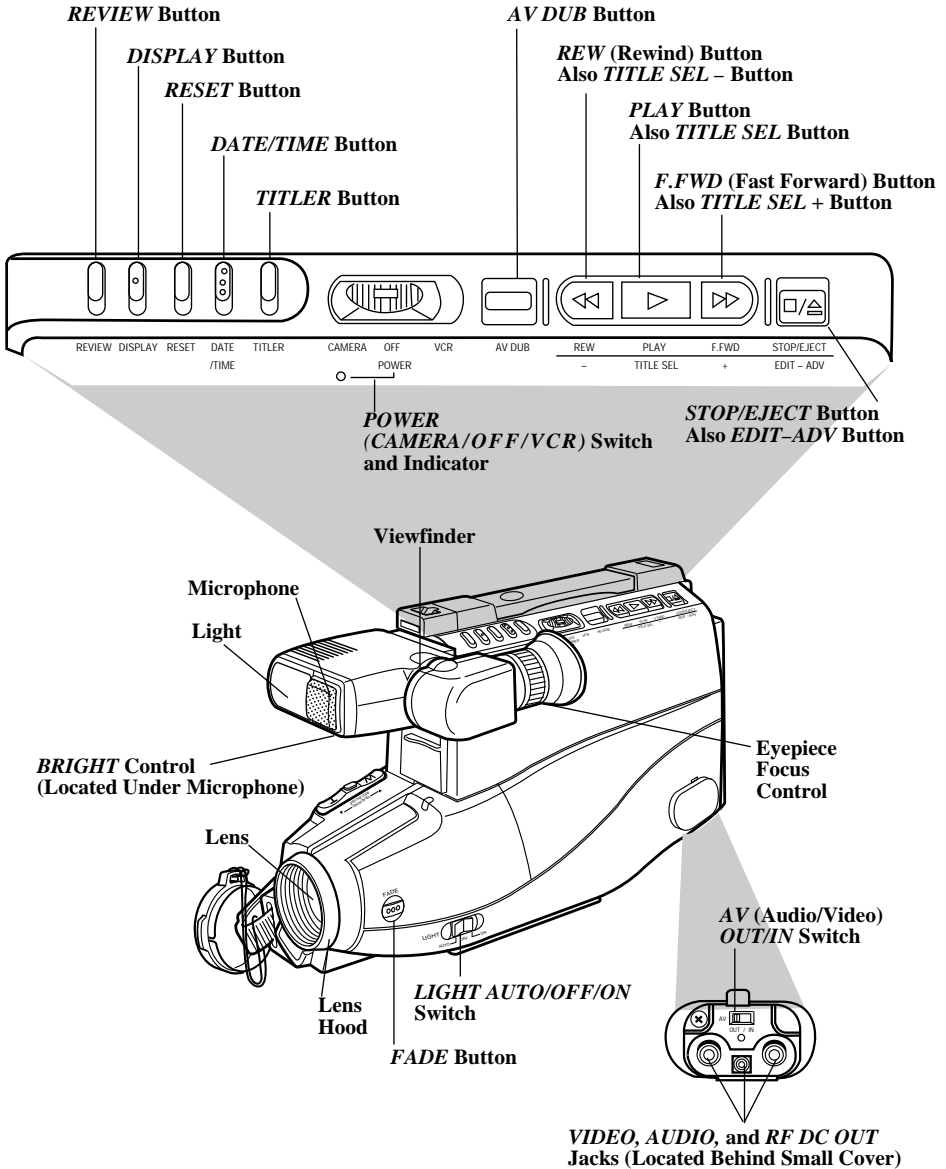

First-Time Operation

9. Review the camcorder's operating controls.

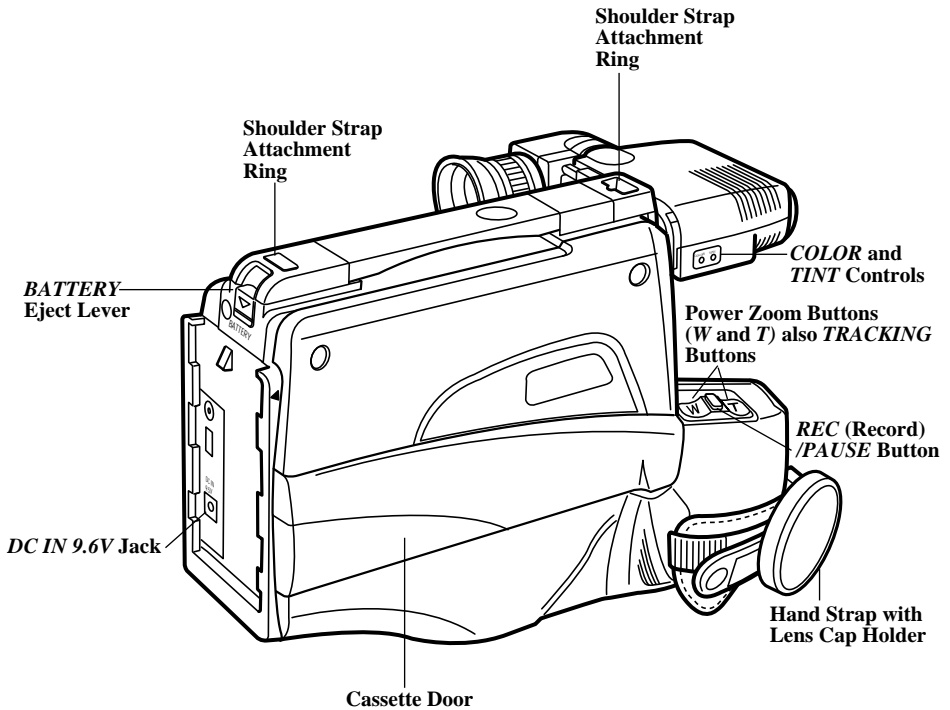

Powering the Camcorder

Caution: Do not attempt to use a “power converter” to use your AC adapter/charger on a power source other than 120 volts, 50/60 Hz, or the adapter/charger and camcorder may be damaged. If you wish to operate the AC adapter/charger on a power source other than 120 volts, 50/60 Hz, use only a transformer-type power converter. **Do not use “solid-state” or “switching-type” power converters. They will damage your AC adapter/charger.** An optional CPS014 shown on page 53 is designed for use on 100-240 volts, 50/60 Hz.

Using the Adapter/Charger to Power Your Camcorder

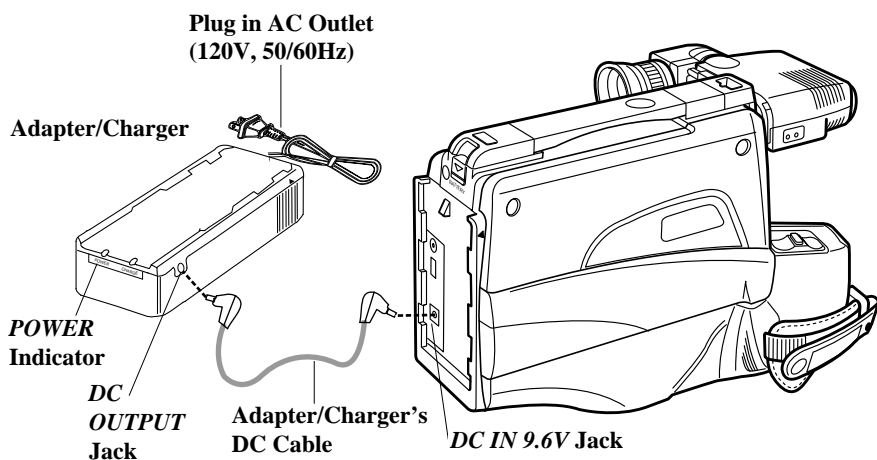

1. Connect one end of the adapter/charger's cable to the adapter/charger's *DC OUTPUT* jack and the other end to the *DC IN 9.6V* jack on the back of the camcorder.
2. Plug the adapter/charger into the nearest AC outlet (120V, 50/60 Hz).
3. The *POWER* indicator on the adapter/charger will light when it is properly connected.

Notes: The adapter/charger cannot charge the battery and operate the camcorder at the same time. If you connect both, the adapter/charger will power the camcorder. Remove the adapter/charger's cable from the *DC OUTPUT* jack to charge the battery.

When using the adapter/charger to power the camcorder, the battery level indicator may display . This indicator is used for battery operation and has no meaning when using the adapter/charger to power the camcorder.

To Remove the Adapter/Charger

1. Remove the adapter/charger's plug from the AC outlet.
2. Remove the adapter/charger's DC cable from the *DC IN 9.6V* jack on the camcorder.

Caution: Do not use this adapter/charger for any purpose other than charging the EP096FS, EP096FL, CB096FS, or CB096FL battery pack or supplying power to the camcorder.

Powering the Camcorder

Using the Battery to Power Your Camcorder

Charging the Battery

The battery must be charged before it can be used the first time. Charging will take approximately two hours depending on the condition of the battery. When fully charged, the battery should supply approximately 60 minutes of operating time (depending on how much you use zoom and pause). To extend the battery's operation time, turn off the camcorder's power when not in use.

WARNING: LEAD-ACID BATTERY. MUST BE DISPOSED OF PROPERLY.

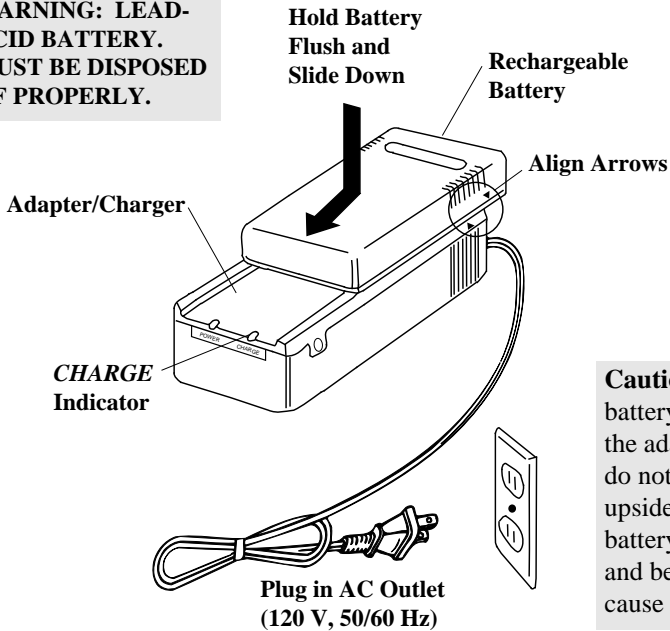

Caution: When a battery is attached to the adapter/charger, do not turn them upside down. The battery may fall off and be damaged or cause injury.

1. Attach the battery to the adapter/charger as shown. Align the reference arrow on the battery with the arrow on the adapter/charger. Hold the battery flush against the adapter/charger and slide it in the direction of the arrow.
Note: You cannot charge the battery and operate the camcorder from the adapter/charger at the same time. Remove the adapter/charger's DC cable from the camcorder to charge the battery.
2. Plug the adapter/charger into the nearest AC outlet (120 V, 50/60 Hz).
3. The *CHARGE* indicator will light while the battery is being charged. When the indicator turns off, the battery is fully charged.
4. Remove the battery from the adapter/charger by sliding the battery up and off.
5. Attach the charged battery to the camcorder *as shown on the next page*.

(continued on next page)

Powering the Camcorder

Using the Battery to Power Your Camcorder

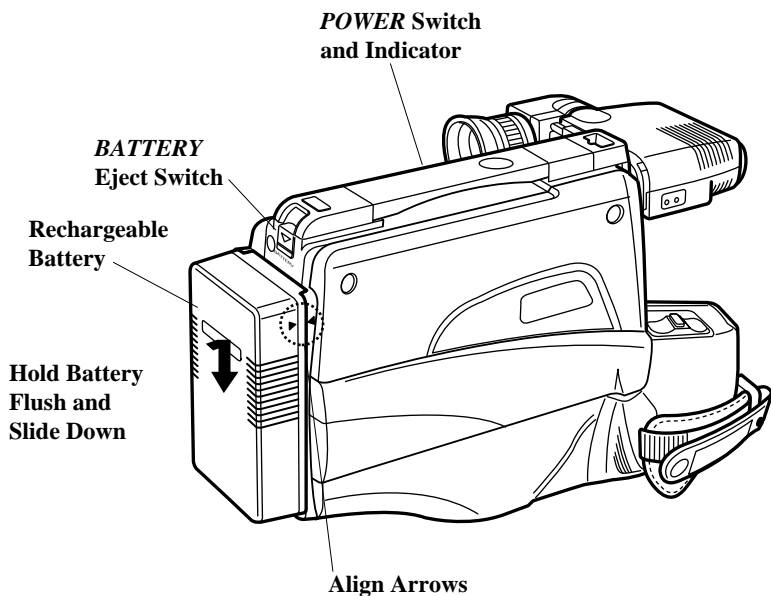

Attach Charged Battery

1. Align reference arrow on battery with arrow on camcorder. Hold battery flush against camcorder while sliding it down in the direction of the arrow as shown.
2. Press and hold small button on *POWER* while placing it in *CAMERA*. *POWER* indicator will light if battery is properly attached.

Remove the Battery

1. Slide *POWER* to *OFF*. *POWER* indicator will turn off.
2. Press and hold *BATTERY* eject while sliding battery up and off the camcorder.

ATTENTION: LEAD-ACID BATTERY MUST BE DISPOSED OF PROPERLY. THE PRODUCT THAT YOU HAVE PURCHASED USES A RECHARGEABLE BATTERY. AT THE END OF ITS USEFUL LIFE, UNDER VARIOUS STATE AND LOCAL LAWS, IT MAY BE ILLEGAL TO DISPOSE OF THIS BATTERY INTO THE MUNICIPAL WASTE STREAM. CHECK WITH YOUR LOCAL SOLID WASTE OFFICIALS FOR DETAILS IN YOUR AREA FOR RECYCLING OPTIONS OR PROPER DISPOSAL.



Pb

Powering the Camcorder

Using the Battery to Power Your Camcorder

Battery Care

- Your battery will provide better service and longer performance if you charge it before and after use, and store it at normal room temperature.
- The battery should be charged at a temperature of 32°F-95°F (0°C-35°C) to prevent damage.
- Do not operate the battery at temperatures below 14°F (-10°C) or above 95°F (35°C). The battery may be damaged if operated at temperatures above 122°F (50°C). Operation time will decrease at extremely low temperatures.
- After repeated chargings and use, the operation time will gradually decrease. When operation time becomes too short to be useful, it is time to replace the battery.

Battery Storage

- Store the battery at normal room temperature.
- Lead acid batteries discharge if not used. Recharge the battery at least once every six months or you may not be able to recharge it.
- A battery stored for a long period may not supply power for the specified time. Additional rechargings may help restore the battery's operation time.

Battery Safety Precautions

Batteries being recharged that have not been used for an extended period may continue to charge after the normal time. Do not charge a battery for more than 24 hours.

If both indicators on the adapter/charger start flashing, remove the battery, and reattach it. If after several attempts — the indicators continue to flash — your battery cannot take a charge and must be replaced.

Throwing the battery into a fire or exposing the battery to excessive heat — over 149° F (65° C) could be hazardous.

Do not short the battery's terminals.

Allow battery to cool down before attaching it to adapter/charger. The *CHARGE* indicator will not light and the battery will not charge if you attach a hot battery.

Do not attempt to disassemble or modify the battery. There are no user-serviceable parts inside.

Use the battery only with specified AC adapter/chargers and camcorders.

If leakage from a damaged battery contacts your skin or clothing, wash it off immediately with running water.

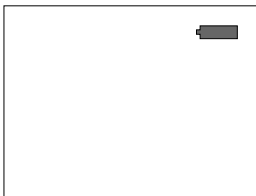

Powering the Camcorder

Check Battery Power (Battery Level Indicator)



**Battery Level Indicator
Display in Viewfinder**

The battery level indicator () always appears in the camcorder's viewfinder to show how much battery power is left in the rechargeable battery. This indicator is not recorded on the tape.

- When the battery is fully charged, the display shows .
- After a while, only  appears.

- When the battery reaches the empty level,  will start flashing. Recharge the battery or attach the adapter/charger before continuing to use the camcorder.

Note: The battery level indicator has no meaning when you power the camcorder with the adapter/charger or optional car cord.

Caution: When the battery reaches its empty level during use, the camcorder will turn off. However, the battery should have enough reserve power to eject the cassette when you press *STOP/EJECT*.

If the camcorder does not eject the cassette when you press *STOP/EJECT*, **do not force the cassette door open**. This will damage your camcorder.

Before attempting to eject the cassette, power your camcorder with the adapter/charger or recharge the battery.

Powering the Camcorder

Using the Optional Thomson Car Cord Adapter

To power your camcorder from the cigarette lighter socket of a car, truck, or RV, you need the optional car cord adapter DCC096 shown on page 53.

The DCC096 car cord is especially designed to convert power from a 12-volt battery to the 9.6-volt input jack on the camcorder.

Caution: The DCC096 car cord is designed to be used only with vehicles having 12-volt negative ground electrical systems.

Warning: To avoid possible damage to your camcorder, use only the DCC096. It has positive tip polarity and is capable of converting 12-volts to 9.6 volts.

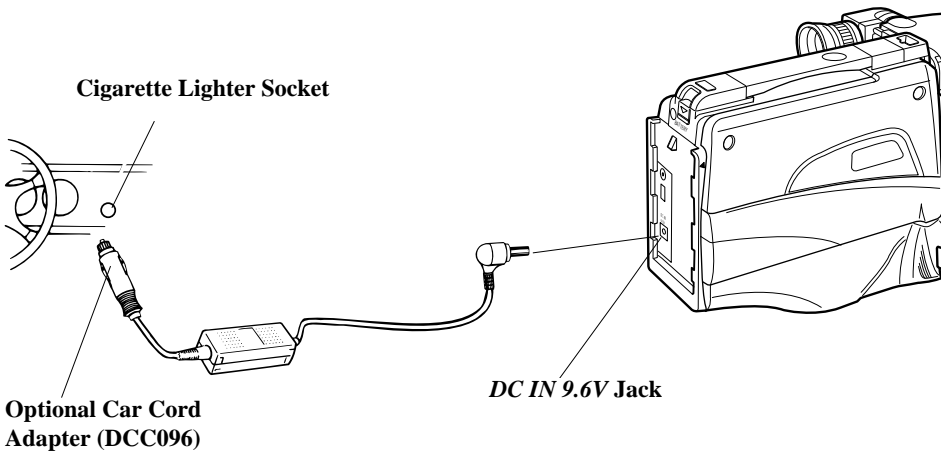

1. Remove the adapter/charger's DC cable or battery from the camcorder, if either is attached.
2. Connect the small plug on the car cord to the *DC IN 9.6V* jack located on the back of the camcorder.
3. Insert the other end of the car cord into the vehicle's cigarette lighter socket.
4. Place the camcorder's *POWER* switch in *CAMERA*. If the car cord is connected properly, the *POWER* indicator will light.

Notes: The vehicle does not have to be turned on for the camcorder to operate from the DC car cord.

When using the car cord to power the camcorder, the battery level indicator may display . This indicator is used for battery operation and has no meaning when using the car cord to power the camcorder.

Video Cassettes

We recommend that our cassettes be used with your camcorder. Use of poor quality tapes or tapes that have been damaged or mishandled can contaminate the video heads, resulting in a snowy picture or no picture at all during playback. Because there is no control over the type of tape purchased or rented by consumers, **head cleaning is not covered under warranty**. It is considered normal maintenance.

If a snowy picture or no-picture condition persists, consider the use of a dry chemical non-abrasive head-cleaning tape. Be sure to follow the directions with the head-cleaning kit carefully. Improper use of a head cleaner may damage your camcorder.

Erase Protection — Safety Tab

You can use your video cassettes over and over again. To erase a previous recording, just record over it.

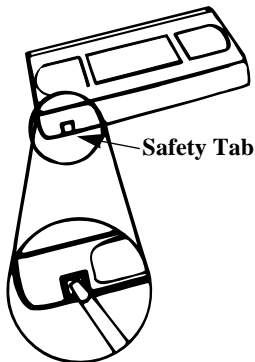

To prevent accidental erasure, break the tab.

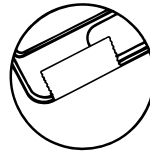

To record again, cover the hole with vinyl tape.

Recording and Playback Times

The camcorder records and plays back in VHS standard speed (SP). The chart shows the maximum SP recording times for popular VHS cassettes.

CASSETTE	RECORDING TIME
T-60	60 Min.
T-120	2 Hrs.
T-160	2 Hrs., 40 Min.
T-180	3 Hrs.

Video Cassettes

Inserting and Removing Cassettes

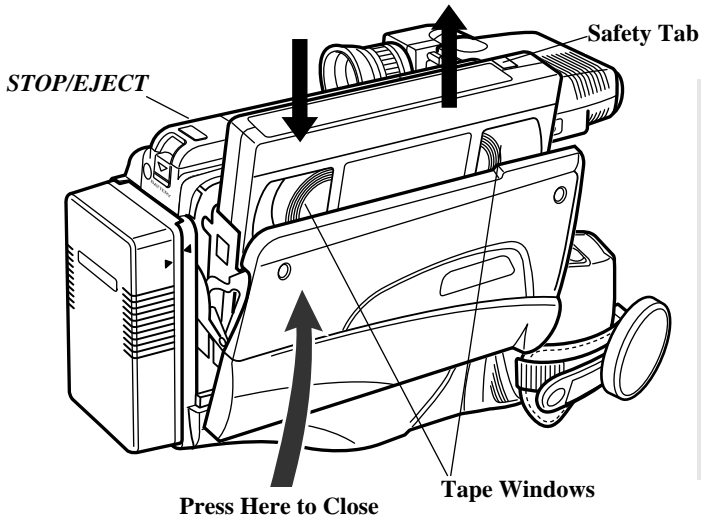

Caution: Insert cassette with safety tab facing up and tape windows facing out. Cassette should slide easily into the compartment. **Gently push the cassette down until it locks into place.**

1. Attach a power source to the camcorder (either a charged battery or adapter/charger).
2. Press *STOP/EJECT* on the top of the camcorder to open cassette door.
3. Insert or remove the cassette from the cassette compartment.
4. Gently close the cassette door with your hand.

Cassette Care and Storage

Follow these directions for continued high-quality performance from your cassettes.

- When you are finished with a cassette, rewind it and remove it from the camcorder.
- Label and store cassettes vertically in their protective cases at normal room temperatures. Excessive heat or cold may damage your cassettes.
- Keep dust from entering the cassette compartment. All dust is abrasive and will cause excessive wear on the tape and the camcorder's recording or playback heads.
- Keep cassettes away from strong magnetic fields, such as electric motors and other devices.
- Do not use a cassette if it has been damaged or exposed to moisture. The tape may jam or damage the camcorder.
- When you are finished recording, break off the safety tab on the cassette to prevent accidental erasure.
- Do not leave your camcorder or cassettes in a car or outdoors for an extended period. Excessive heat or cold may damage them.

Camcorder Traveling and Cassette Tips

Traveling Tips

Write down your camcorder's serial number and keep it separate from the camcorder when traveling. If your camcorder is lost or stolen, you will be able to identify it.

Make sure you have any plug adapters you need before taking your camcorder to other countries. Consult your dealer.

Use extra care to avoid damage to your camcorder and accessories when operating them at a beach or pool. Spray, sand, and dust should be avoided. If your lens has been exposed to the elements, clean it only with proper lens cleaning supplies.

Carry your camcorder in the carrying case when traveling. *See page 52* for a specially designed soft case. An ordinary suitcase or carry bag does not offer the protection your camcorder needs. Treat your camcorder as carry-on luggage to protect it from rough handling.

Cassette Tips

Do not use a cassette if it has been damaged or exposed to moisture. The tape may jam or damage your camcorder.

When you are finished recording, break off the safety tab on the cassette to prevent accidental erasure.

Label your cassettes before storing them.

Store your cassettes vertically in their protective cases at normal room temperature.

Do not leave your camcorder or cassettes in a car or outdoors for an extended period. Excessive heat or cold may damage them.

Camcorder Features

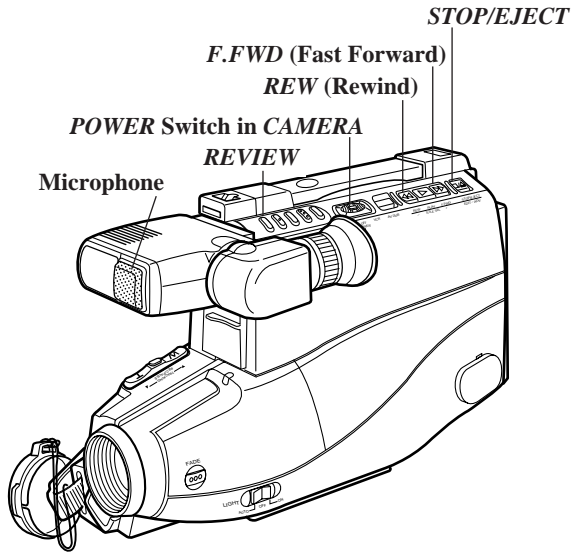

Quick Review

Press *REVIEW* when *POWER* is in *CAMERA* and the camcorder is in record pause to review the last few seconds of a recording.

The camcorder will play back the last few seconds of the recording, return the tape to its previous position, and return to record pause.

Tape Positioning

When *POWER* is in *VCR* and the camcorder is in the stop mode, you can quickly fast-forward or rewind the tape.

- Press *F.FWD* (fast forward) to fast forward the tape. Press *STOP/EJECT* to stop fast-forwarding.
- Press *REW* (rewind) to rewind the tape to the beginning. Press *STOP/EJECT* to stop rewinding.

Microphone

The microphone picks up sound during a recording. It is more sensitive to sounds coming from the direction the lens is pointed.

AI (Artificial Intelligence)

The camcorder will automatically adjust focus, white balance and iris according to the recording conditions.

Camcorder Features

Program AE (Auto Exposure)

Program auto exposure automatically selects the shutter speed and adjusts the iris according to the shutter speed.

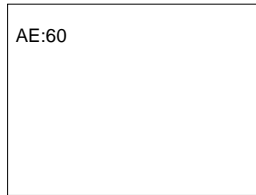

Viewfinder Display

The AE indicator for the shutter speed selected (*1/60, 1/100, 1/120, 1/180, 1/250, 1/350, 1/500, 1/750, 1/1000, 1/1500, 1/2000, or 1/4000* second) appears in the viewfinder.

Auto Focus

The camcorder will focus on the subject in the center of the viewfinder.

Auto focus operates on the telephoto “T” side from approximately 3.6 feet to infinity and on the wide-angle “W” side 3/8 of an inch from the lens surface to infinity.

The following conditions may prevent auto focus from operating properly.

- Subject has close foreground and background far away.
- Two subjects at different distances that overlap.
- Subject with distinct horizontal stripes or small pattern.
- Subject not in center of the viewfinder.
- Subject with shiny surfaces or sharp angles.
- Recording in low-light situations.
- Recording through a window.

Macro Focus

The macro-focus feature lets you focus on objects as close as 3/8 of an inch from the camcorder lens.

1. Press and hold zoom button “W” until the lens is completely zoomed out.
2. Position the subject in the center of the viewfinder.

Notes: Zooming is not possible when using macro focus. To change the size of the subject, move the camcorder’s lens closer or farther away from it.

For best results, increase illumination when recording using macro focus.

Camcorder Features

Electronic Indexing

Each time you begin recording (after the camcorder has been turned off for at least four hours), the camcorder will automatically record an index mark at the beginning of the new recording.

When you play back the indexed tape in a VCR that has a compatible indexing feature called “VHS Index Search System”, the invisible marks can be located automatically. See your VCR owner’s manual for index playback instructions.



Viewfinder Display

INDEX will appear briefly in the viewfinder to let you know the camcorder is recording an index mark.

Note: The camcorder does not record index marks every time you stop and start recording. An index mark is recorded only once — at the start of each day’s recording session (or whenever the camcorder has been turned off for at least four hours).

Time Remaining Display

The time remaining display shows the amount of recording or playback time left on the tape in the camcorder.

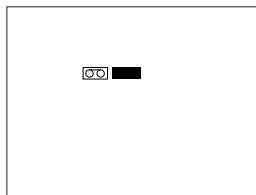

Viewfinder Display

“-----” will appear for approximately ten seconds when you first start playing or recording a tape while the camcorder calculates the time remaining.

Once time remaining has been calculated, it will automatically be updated and readily available as long as the same tape remains in the camcorder.

Viewfinder

The camcorder's viewfinder is a miniature monitor that displays the picture seen by the camcorder when recording. The viewfinder also can be used for viewing the tape during playback.

When carrying or storing the camcorder, return the viewfinder to the original position to prevent possible damage.

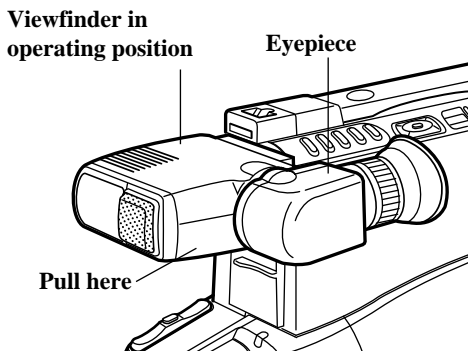
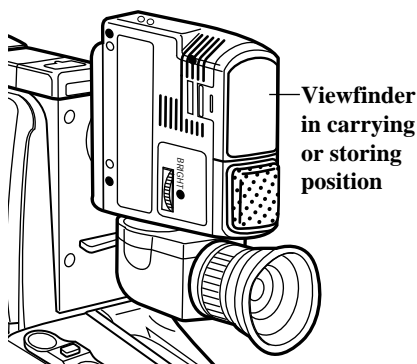

Caution: Pulling on the eyepiece may cause damage to the camcorder.

1. Grasp the viewfinder and rotate it horizontally.
2. Pull the viewfinder out from the camcorder and adjust the eyepiece for convenient viewing.

Eyepiece Focus Control

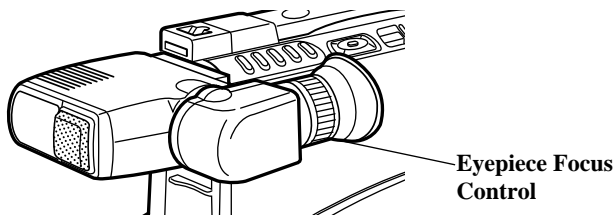

The eyepiece focus control lets you set the focus of the viewfinder for your personal vision. If you wear eyeglasses, you probably can operate the camcorder without them.

Set the correct focus by focusing on one of the viewfinder's displays (such as the

counter). Look through the viewfinder, and adjust the eyepiece focus control for your vision.

The eyepiece focus control does not affect the focus of the picture actually recorded by the camcorder.

Viewfinder

Eyepiece *BRIGHT*, *COLOR*, and *TINT* Controls

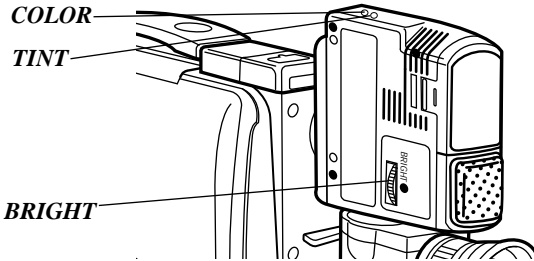

***BRIGHT* Control**

Viewfinder brightness can be adjusted by turning the *BRIGHT* control. This does not affect the picture actually recorded by the camcorder.

***COLOR* and *TINT* Controls**

The small *COLOR* and *TINT* controls are set at the factory and should require no adjustment.

Tilt Adjustment

For convenient viewing, you can rotate the eyepiece about 225° degrees.

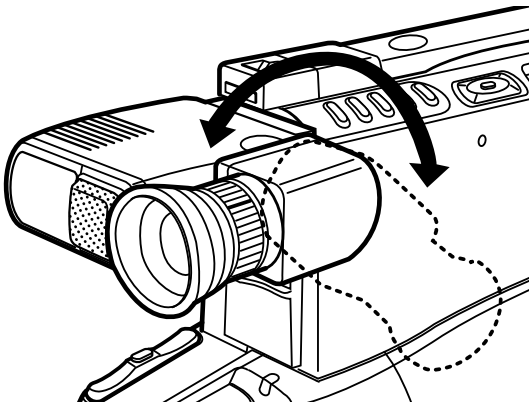

Caution: Do not force the eyepiece to rotate completely around. This will damage the eyepiece and/or the camcorder.

Displays in Viewfinder

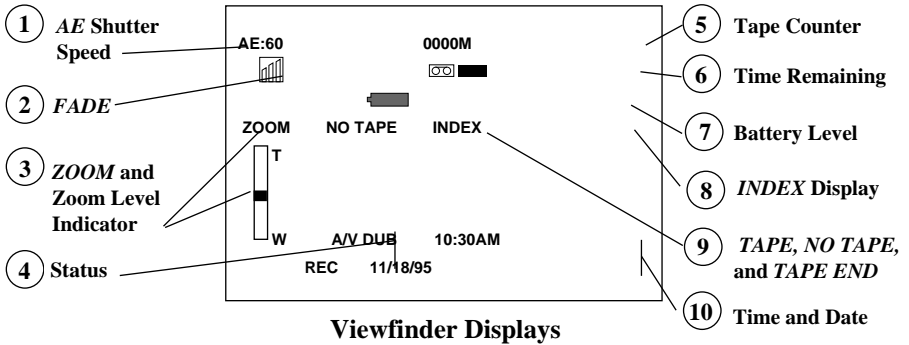



① AE (Auto Exposure) Shutter Speed

The shutter speed selected by the camcorder appears here. It is not recorded on the tape.

② Fade

Press *FADE* to select white, wipe, or zoom fade. It is not recorded on the tape.

-  appears for white fade.
-  appears for wipe fade.
-  appears for zoom fade.
- *Details are on page 29.*

③ ZOOM and Zoom Level

- The zoom level indicator appears when you press power zoom button *T* or *W*. *ZOOM* appears when you zoom in more than 12 times.
- *Details are on page 28.*

④ Status

The following displays appear in this area. They are not recorded on the tape.

- *A/V DUB* for audio/video dubbing.
- *A. DUB* for audio dubbing.
- *REC* for recording.
- *66* during fast forward.
- *55* during rewind.
- *||* during record pause.

⑤ Tape Counter with Memory Stop (M)

The tape counter helps you locate tape segments. It is not recorded on the tape.

- Press *DISPLAY* to turn memory stop on or off.
- *Details are on page 30.*

⑥ Time Remaining ()

This display shows the amount of recording or playback time remaining on the tape. It is not recorded on the tape. *Details are on page 21.*

Displays in Viewfinder

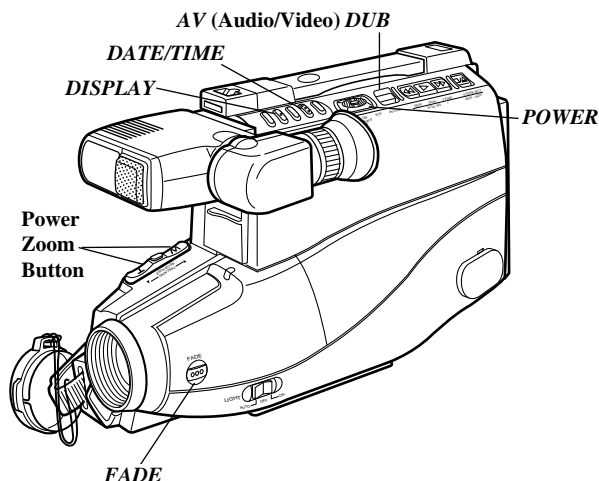

7 Battery Level ()

This indicator shows the amount of time left for the rechargeable battery. It is not recorded on the tape. *Details are on page 14.*

8 INDEX

INDEX appears briefly when the camcorder automatically indexes the tape. It is not recorded on the tape. *Details are on page 21.*

9 TAPE, NO TAPE, and TAPE END

- TAPE flashes when you try to record and the safety tab has been removed.
- TAPE flashes when a damaged tape is inserted. Remove the tape and replace it with a new one.
- NO TAPE flashes when you try to record and there is no cassette in the camcorder.

- TAPE END flashes when you have approximately three minutes recording time left on the cassette.
- TAPE END briefly appears when you reach the end of the cassette during recording.
- These displays are not recorded when they appear.

10 Time and Date Display

- Press DATE/TIME repeatedly to display time and date, AUTO date, date only, or no date display when the camcorder is in record pause.
- These displays are recorded when they appear.
- *Details are on pages 26-27.*

Date and Time Display

Set the Time and Date

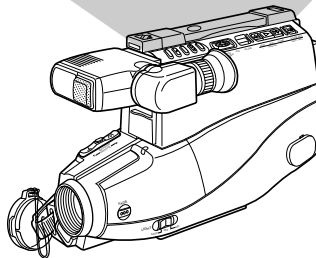
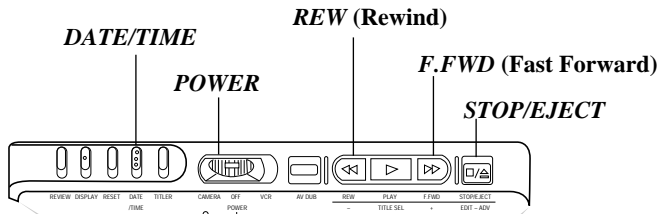

1. Attach a power supply (battery or adapter/charger) to the camcorder.
2. Press and hold the small button on **POWER** and place in **CAMERA**.
3. Press **DATE/TIME** to display the date and time in the viewfinder. A flashing cursor lets you know which part of the display you are setting.
5. When the correct digit is displayed, press **STOP/EJECT**. The cursor will move to the next part of the display.
6. Repeat steps 4 and 5 to set the correct month, day, year, hour, minute(s), and **AM/PM**.
7. After setting **AM** or **PM**, press **DATE/TIME** to remove the flashing cursor and start the internal clock.

Note: If flashing cursor does not appear, press and hold **DATE/TIME** and then press **STOP/EJECT**.

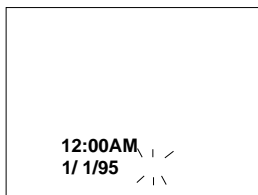

4. Repeatedly press **F.FWD** or **REW** until correct month appears. Press and hold the button to advance the digits faster.

To Correct the Date or Time

To correct the date or time, press and hold **DATE/TIME** and then press **STOP/EJECT**. The display will appear in the viewfinder along with the flashing cursor. Use **F.FWD** and **REW** to correct the time or date. Press **DATE/TIME** to remove the flashing cursor and start the clock.

Date and Time Display

Recording Date and Time (or Date) on Your Tape

The time and date (or date only) can be recorded on your tape. Whenever one of the displays appears in the viewfinder, it will be recorded.

The camcorder has an auto-date feature that will record the date only for approximately ten seconds when you begin recording.

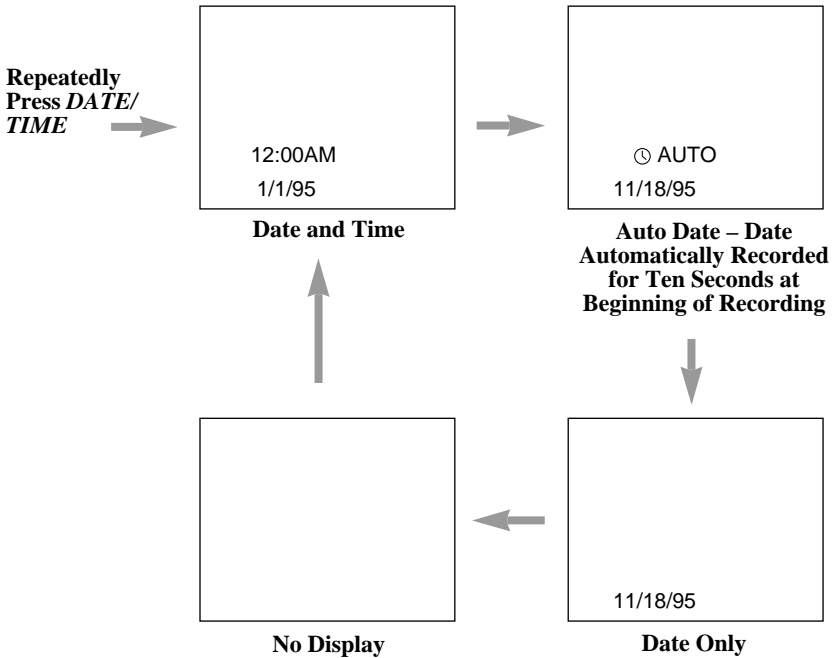

Charging the Camcorder's Built-in Clock Battery

The camcorder has a built-in rechargeable clock battery.

This battery must be charged approximately every two months.

1. Attach a power supply (adapter/charger or charged battery) to the camcorder.
2. Make sure *POWER* is in *OFF*.
3. Leave the power supply attached at least 24 hours.

Cautions: If this battery is not charged every two months, it will over-discharge and shorten its useful life.

Do not attempt to replace this battery. Take the camcorder to an authorized Servicenter.

Zooming

Power Zoom Buttons

T = Telephoto

W = Wide Angle

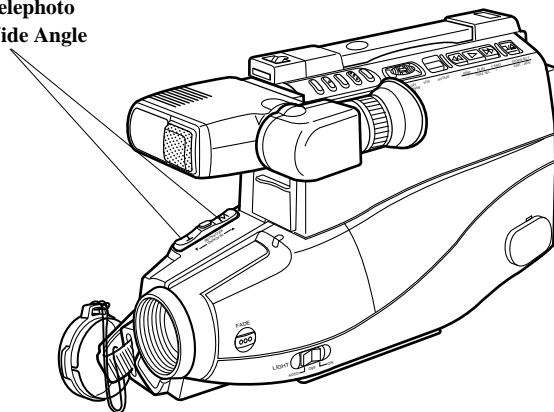

Using Power Zoom Buttons

ZOOM and Zoom Level Indicator

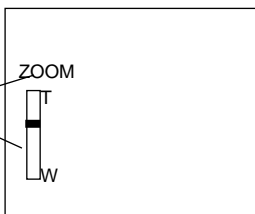

To zoom in or out slowly, press the zoom button lightly. To zoom in or out quickly, press the zoom button firmly.

- Press “T” to move the lens in the “telephoto” (close-up) direction.

ZOOM appears in the viewfinder when you zoom in more than 12 times.

- Press “W” to move the lens in the “wide-angle” direction.

The zoom level indicator will appear briefly in the viewfinder.

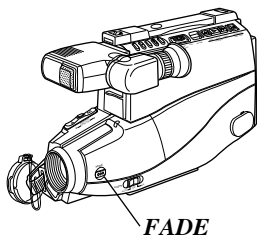

Fading In and Out of Scenes

You can add a professional touch to your recordings when you fade in and out of scenes. Both the picture and sound will gradually appear or disappear. The speed of the fade is controlled by the camcorder.



Select the Type of Fade

You can select white, wipe, or zoom fade.

- Select white fade to fade in and out from a white screen.  appears in the viewfinder.
- Select wipe fade to fade in and out from a black screen.  appears in the viewfinder.
- Select zoom fade to fade in and out while zooming.  appears in the viewfinder.

Repeatedly Press *FADE*

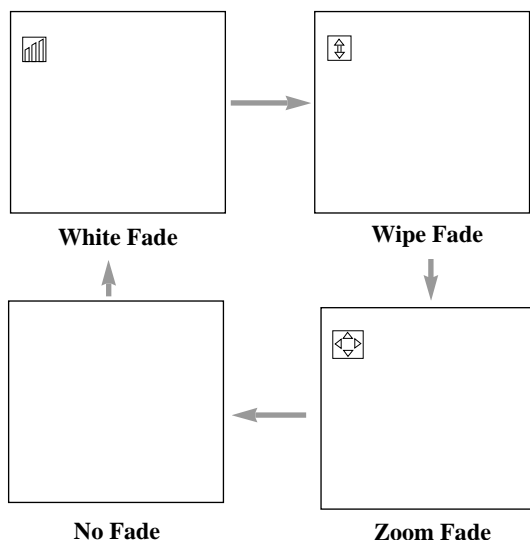

Fade In

1. Place the camcorder in record pause.
2. Repeatedly press *FADE* to select fade mode.

Note: The last fade mode used will appear the first time you press *FADE*.

3. Press *REC/PAUSE* to start recording. The picture and sound will gradually appear in place of the blank screen.

Fade Out

1. During recording, repeatedly press *FADE* to select the fade mode.

Note: The last fade mode used will appear the first time you press *FADE*.

2. Press *REC/PAUSE* to stop recording. The picture and sound will gradually disappear.

Tape Counter with Memory Stop

The tape counter is automatically displayed in the viewfinder and acts as a handy reference to help you locate tape segments.

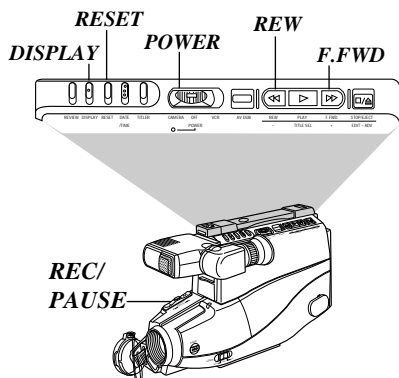

Memory Stop

The tape counter's memory stop helps you locate a certain point on the tape. When memory stop is turned on, the tape will stop automatically during fast forward or rewind when the tape counter reaches "0000M".

Using Memory Stop:

1. Press *DISPLAY* to turn memory stop on. "M" appears after tape counter when memory stop is turned on.
2. Locate the place on the tape you want to return to and press *RESET* to reset tape counter to "0000M".
4. Make sure *POWER* is in *VCR*. Then press *REW* (rewind). The tape will rewind until it reaches the tape counter reading of "0000M".

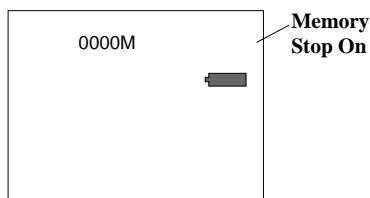

3. Continue to record or play the tape. When you want to return to the place you marked, press *REC/PAUSE* to stop recording, or press *STOP/EJECT* to stop playback.

Notes: Press *DISPLAY* to turn memory-stop feature on or off.

Whenever memory stop is turned on, the camcorder will stop rewinding or fast forwarding when the counter reaches "0000M". To continue rewinding or fast forwarding the tape, press *REW* (rewind) or *F.FWD* (fast forward) again.

The tape counter is automatically reset to "0000" whenever a cassette is inserted.

ProEdit Features

ProEdit® System



- Flying Erase Head
- Edit Search
- Audio Dub
- A/V (Audio and Video) Dub
- Titler

The camcorder incorporates a complete package of advanced editing features to make it easy and fun to edit your home videos like a professional. The major ProEdit® System features *are described here and on the following pages.*

Flying Erase Head



A separate erase head is mounted on the spinning headwheel (hence the term “flying”). The flying erase head allows you to make clean edits without “glitches” or “rainbow noise”.

Edit Search



The edit-search feature allows you to edit as you make your recording by using *F.FWD*, *REW*, and *PLAY* to precisely position the tape while the camcorder is in record pause.

- Press and hold *REW* (rewind) to visually search the recorded tape in reverse.
- Press and hold *F.FWD* (fast forward) to visually search forward on the recorded tape.
- Press and hold *PLAY* to view the recorded tape at normal speed.

When you release the button, the camcorder will return to record pause at that point on the tape.

ProEdit Features

Audio Dubbing

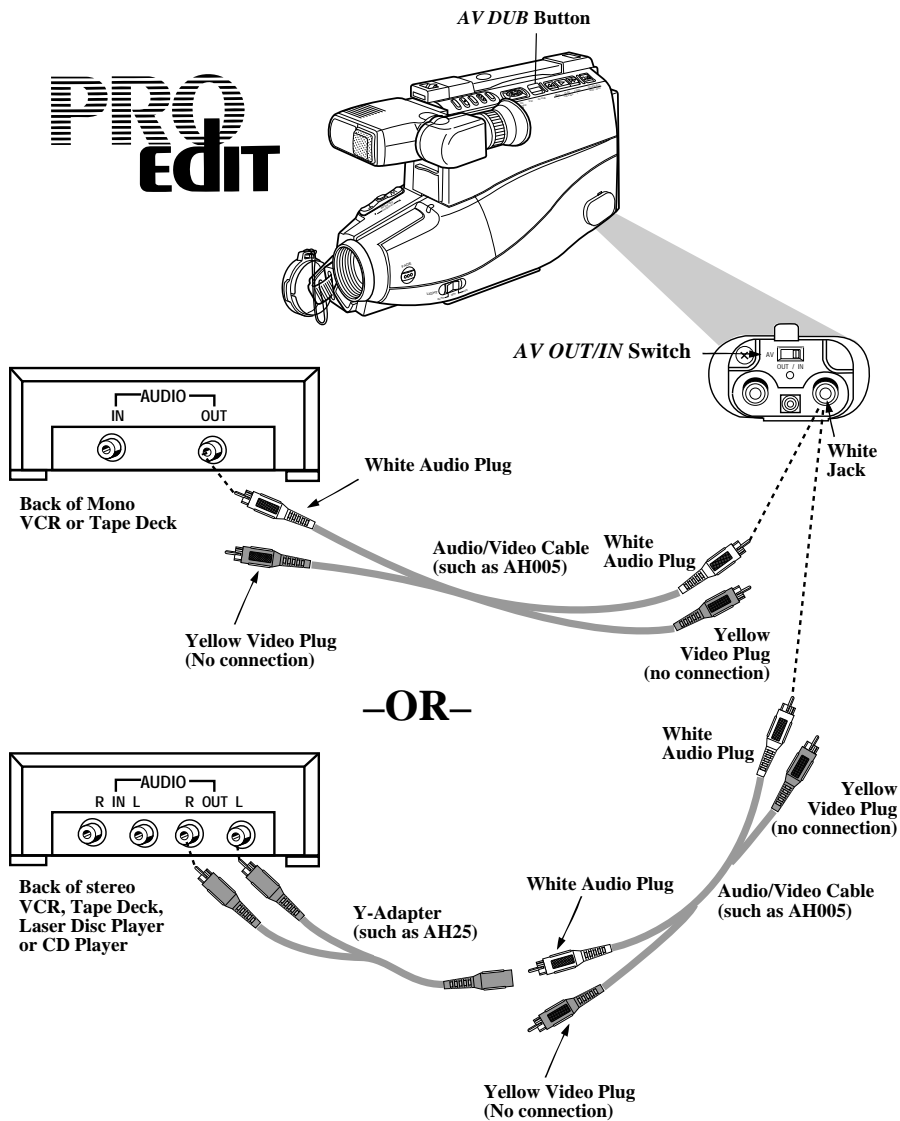

Note: You will need an optional audio/video cable, such as AH005 shown on page 54. If the audio source has separate left and right outputs, attach the audio plug to the one labeled *MONO*. If one is not labeled *MONO*, you may need a Y-adaptor, as shown on page 54, to record audio from both the left and right channels.

Audio Dubbing



The audio dub feature lets you record new audio (sound) on a previously recorded tape without erasing the original video (picture). The previous audio is erased and replaced with the new audio.

The audio dub feature increases your editing flexibility. Video segments can first be assembled and then a single narration or music background can be added.

The new audio can be added two different ways.

- You can speak into the camcorder's built-in microphone.
- You can connect an external sound system to the white *AUDIO* jack on the camcorder.

To Audio Dub

1. Press and hold the small button on *POWER* while sliding it to *VCR*.
2. If you are recording from a source connected to the white *AUDIO* jack on the side of the camcorder, place *AV OUT/IN* switch to *IN*.
3. Insert the tape you want to audio dub and use *PLAY*, *F.FWD*, and *REW* to locate a point on the tape a few seconds before you want to begin dubbing.
4. Press *REC/PAUSE* exactly where you want to begin dubbing. This will place the camcorder in play pause.
5. Press and hold *AV DUB*, and then press *PLAY*. Release both buttons at the same time. *A. DUB II* will appear in the viewfinder when the camcorder is ready to begin audio dubbing.
6. To begin dubbing, start the audio source and press *REC/PAUSE*. *II* will disappear from the viewfinder while you are dubbing.
7. Press *STOP/EJECT* when you are finished dubbing.

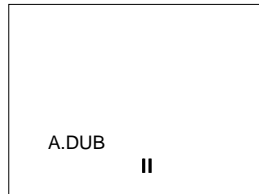

Remember: Place the *AV OUT/IN* switch to *OUT* to record on the camcorder.

Notes: If you want to stop dubbing at a certain point on the tape, turn on memory stop, and set tape counter to "0000M" at the point where you want the dubbing to stop. The camcorder will stop dubbing automatically when it reaches "0000M".

Audio and Video Dubbing



The audio and video dubbing feature lets you record new audio (sound) and video (picture) on a previously recorded tape in the camcorder.

The source for the dubbing is the camcorder's microphone and camera or a source connected to the *AUDIO/VIDEO* jacks on the side of the camcorder.

- To record from the camcorder's microphone and camera, no special connections are required.
- To record from an external video source (VCR, LaserDisc player, etc.), you will need an optional audio/video cable, such as AH005 shown on page 54.

To Audio and Video Dub

1. Press and hold the small button on *POWER* while sliding it in *VCR*.
2. If you are recording from a source connected to the *AUDIO/VIDEO* jacks on the side of the camcorder, place the *AV OUT/IN* switch to *IN*.
3. Insert the tape you want to dub and use *PLAY*, *F.FWD*, and *REW* to locate a point on the tape a few seconds before you want to begin dubbing.
4. Press *REC/PAUSE* exactly where you want to begin dubbing. This will place the camcorder in play pause.
5. Press and hold *AV DUB*, and then press *PLAY*. Release both buttons at the same time. *A. DUB ||* will appear in the viewfinder when the camcorder is ready to begin audio dubbing.
6. Press and hold *AV DUB*, and then press *PLAY* again. Release both buttons at the same time. *AV DUB ||* will appear in the viewfinder when the camcorder is ready to begin audio and video dubbing.

Note: If you are dubbing from a source connected to the *AV OUT/IN* jacks, be sure to start it playing.



7. To begin dubbing, press *REC/PAUSE*. *||* will disappear from the viewfinder while you are dubbing.
8. Press *STOP/EJECT* when you are finished dubbing.

Remember: Place the *AV OUT/IN* switch to *OUT* to record on the camcorder.

Notes: If you want to stop dubbing at a certain point on the tape, turn on memory stop and set the tape counter to "0000M" at the point where you want the dubbing to stop. The camcorder will stop dubbing automatically when it reaches "0000M".

ProEdit Features

Titler

PRO EDIT

The camcorder's built-in titler can store two different titles in memory. Either title can be displayed and recorded at any time.

The built-in character register contains over 45 different characters for creating your titles. Each title can contain up to 32 characters on two lines.

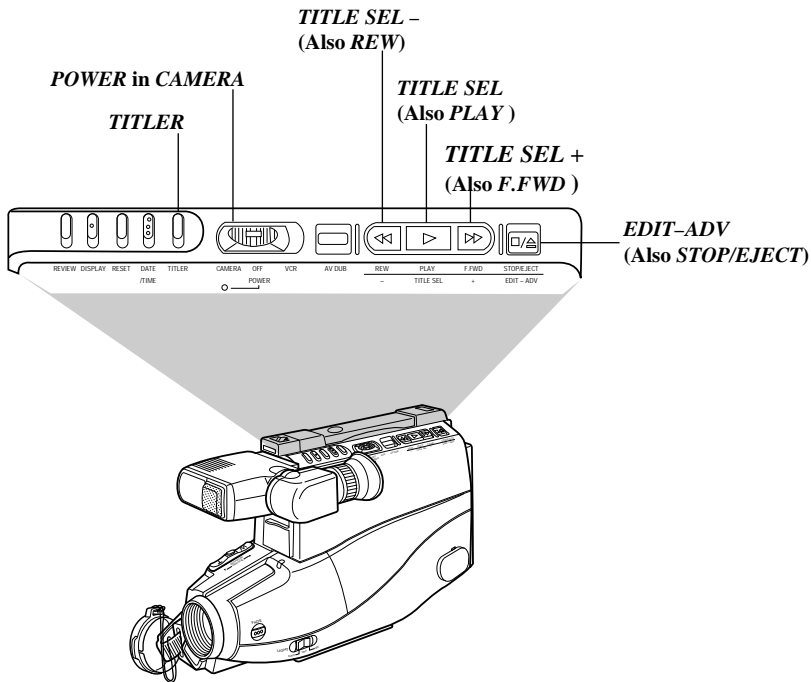

ProEdit Features

To Create a Title

1. Attach a power source to the camcorder, press and hold the small button on **POWER** while sliding it to **CAMERA**. **POWER** indicator will light.
2. Press **TITLER** to display titler graphics in the viewfinder. A flashing cursor will appear.
Note: Press **TITLE SEL** (select) to select the other title page. Each time you press **TITLE SEL**, it will switch between the two title pages.
3. Press **EDIT-ADV** to move the flashing cursor to the place you want to begin your title.
4. Select the first character for your title by pressing **TITLE SEL +** or **TITLE SEL -** until the character you want appears in the viewfinder.

Notes: You can scroll through the character register at a faster pace by pressing and holding **TITLE SEL +** or **TITLE SEL -**.

See the "Chart of Characters in Titler's Register" below for the characters available.

5. After you have selected the first character, press **EDIT-ADV** to move the flashing cursor where you want your next character to appear.
6. Repeat steps 4 and 5 until you have completed the title.
7. Press **TITLE SEL** if you wish to create another title on the other title page.
8. When you are finished, press **TITLER** to store the title and remove the title display from the viewfinder.

Important Note: Remember to remove the titler graphics from the viewfinder for normal recording.

To Correct an Error

1. Press **TITLER** to display the titler graphics in the viewfinder.
2. Press **EDIT-ADV** until the flashing cursor is placed over the character you wish to correct.

3. Press **TITLE SEL +** or **TITLE SEL -** until the correct character appears.

Note: If you want to delete a character, press **TITLE SEL +** or **TITLE SEL -** until the blank space appears.

Chart of Characters in Titler's Register

A	B	C	D	E	F	G	H	I	J	K	L	M	N	O	P	Q	R	S
T	U	V	W	X	Y	Z	0	1	2	3	4	5	6	7	8	9	?	'
.	/	,	-	;	:	<	>	!	(BLANK)									

(continued on next page)

Recording Titles on a Tape in the Camcorder

To record a title on a tape in the camcorder, follow the steps below.

1. Attach a power source to the camcorder, slide *POWER* to *CAMERA*.
2. Locate the place on the tape where you want to record the title.
Notes: If you record a title on a pre-recorded tape, the audio and video will be erased where the title is inserted. There will also be a three-to-four second pause of blank tape before the existing audio and video return.
Audio and video dubbing titles onto existing tapes will eliminate the pauses of blank tape. *Details are on pages 34-35.*
3. Press *TITLER* to display the titler graphics in the viewfinder.

- Note:** If you want to record the other title page, press *TITLE SEL* to display it in the viewfinder.
4. Press *REC/PAUSE* to start recording the title.
 5. After you have recorded the title for the desired length of time, press *TITLER* to remove titler graphics from the viewfinder. The camcorder will now record as normal. If you do not want to continue recording, press *REC/PAUSE*.

Important Note: Remember to remove the titler graphics from the viewfinder for normal recording.

Recording Titles While Copying a Tape from Camcorder to Another VCR

This method of adding titles lets you keep the original tape as it is, and add titles to the copy you are making on another VCR. Connect your camcorder to a VCR *as shown on pages 44-45*.

1. Attach a power source to the camcorder.
2. Place the tape you want to copy in the camcorder and place *POWER* in *VCR*.
3. Press *TITLER* to display the title you want to record. If you want to record the other title page, press *TITLE SEL*. The camcorder will recall the last title page displayed the next time you press *TITLER*.
4. Press *TITLER* to remove titler graphics from the viewfinder.
5. Place a blank tape in the VCR, and place the VCR in record pause.
6. Start copying the tape from the camcorder to the VCR. *Details for copying a tape are on pages 44-45.*
7. When you see the place on the tape you want to insert the title, press *TITLER*.
8. After you have recorded the title for the desired time, press *TITLER* to stop recording the title.
9. Stop the camcorder and VCR when you are finished copying the tape.

Important Note: Remember to remove the titler graphics from the viewfinder for normal playback.

Recording Tips

Make a recording of your home and contents to store in a safe place in case of fire or theft.

Practice recording under a variety of lighting conditions. This will help you respond quickly whenever you see a scene you want to record.

Fading in and out of scenes may make your videos appear more professional.

Do not move the camcorder rapidly from side-to-side while recording. A steady, gradual “pan” avoids blurring and “jitter”.

Use the viewfinder to make sure the camcorder is level while recording or your scenes will appear “tilted”.

Make sure indoor scenes are well-lit to improve picture quality and color reproduction.

Do not bump or tap the camcorder’s microphone while recording because this sound will be recorded.

Be aware of video and audio backgrounds. Background details barely noticed while you are taping may show up as visual “clutter” on your recording. Background noises (especially TV sets, radios, household appliances, traffic sounds, etc.) can detract from the sound you want to record.

Avoid long “still” shots of landmarks and scenic attractions. Recordings are more interesting if they include people and details. “Local color” will give travel videos lasting appeal. Consider recording a familiar or landmark scene from an unfamiliar vantage point for added interest. Remember to check the lighting before starting to record.

Try to avoid taping backlit subjects indoors. Bright light behind your subject may cause the subject to appear too dark.

Include close-up shots of individuals when taping family outings or group functions.

For a different perspective, try kneeling down (or laying) on the floor when recording children or pets.

Recording on the Camcorder from a VCR or TV Monitor

To record on a tape in your camcorder from a VCR or TV monitor with *AUDIO OUT* and *VIDEO OUT* jacks, you will need an optional audio/video cable, such as AH005 shown on page 54.

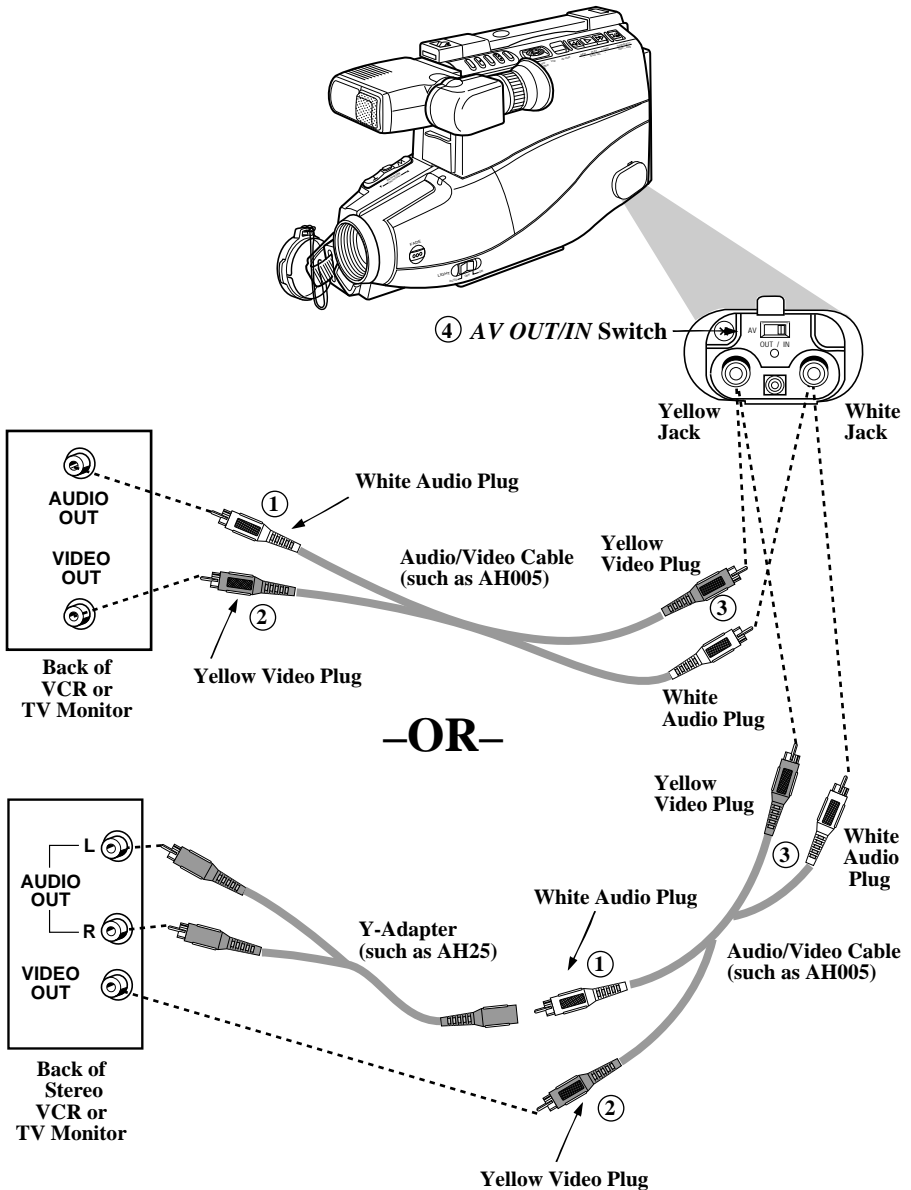

Recording on the Camcorder from a VCR or TV

Installation

- ① Attach the white plug on one end of the audio/video cable to the *AUDIO OUT* jack on the VCR (or TV monitor).
Note: If your VCR or TV monitor has stereo left and right *AUDIO OUT* jacks, attach the plug to the one labeled *MONO*. If one of the audio jacks is not labeled *MONO*, you may need a Y-adaptor, such as AH25 shown on page 54, to hear both channels.
- ② Attach the yellow plug on the same end to the *VIDEO OUT* jack on the VCR (or TV monitor).
- ③ Attach the yellow plug on the other end of the audio/video cable to the yellow *VIDEO* jack and the white plug to the white *AUDIO* jack on the side of the camcorder.
- ④ Place the *AV OUT/IN* switch to *IN*.

Recording Operation and How to Copy Tapes on the Camcorder

1. A. Camcorder connected directly to TV monitor: Turn on the TV and tune it to the channel you want to record.
B. Camcorder connected to a VCR that is already connected to a TV: Turn on the VCR and select the channel you want to record (or place the cassette you want to copy in the VCR). If you are copying a tape, press *PLAY* on the VCR when you are ready to start copying.
Note: If you want to see what is being recorded, turn on the TV and tune it to the channel that you normally use to see the signal from the VCR.
2. Press and hold the small button on the camcorder's *POWER* switch while sliding it to *CAMERA*.
3. Insert a cassette in the camcorder with the safety tab intact.
4. Press *REC/PAUSE* to start the camcorder recording.
Note: If you are copying a tape, start the VCR playing the tape.
5. Press *REC/PAUSE* on the camcorder when you are finished.
Remember: Place the *AV OUT/IN* switch to *OUT* to record on the camcorder.

Caution: The unauthorized recording of television programs and other materials may infringe the rights of others.

Viewfinder Playback and Playback Features

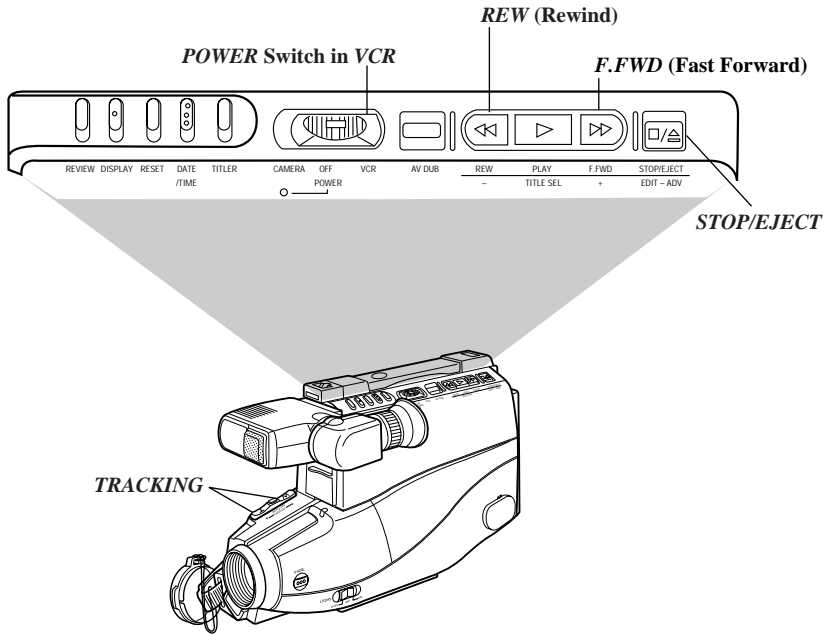

Viewfinder Playback

1. Attach a power supply to the camcorder.
2. Press and hold the small button on **POWER** while sliding it to **VCR**.
3. Press **STOP/EJECT** and insert the cassette you want to play back.
4. Press **PLAY** to begin playback. Adjust **TRACKING** if necessary.
5. Press **STOP/EJECT** when you are finished.

Note: The camcorder can only play back tapes recorded at SP speed.

Viewfinder Playback and Playback Features

Playback Features

Stop-Action Pause

During playback, you can view one frame of the tape.

- Press *REC/PAUSE* to stop the action.
- Press *REC/PAUSE* again to return to normal playback.

Caution: Pause is designed for momentary interruptions and should not be used for an extended period of time. If the camcorder remains in pause for more than five minutes, it will automatically remove the tape from the spinning heads to prevent excessive tape wear.

Picture Search

During playback you can visually search the tape at a higher speed in forward or reverse.

- Press and hold *F.FWD* to search the tape forward.
- Press and hold *REW* to search the tape in reverse.
- Release the button to return to normal playback.

Tracking

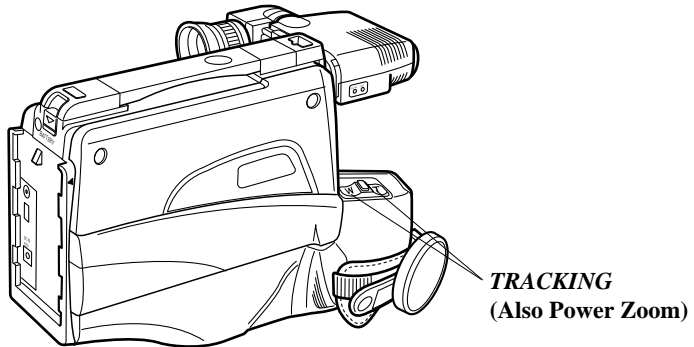

When you play a tape not recorded on your camcorder, streaks may appear. To remove the streaks, press either *TRACKING* button to move the streaks up or down and out of the picture.

Press either *TRACKING* button during stop-action (play-pause) to reduce picture “jitter” (picture bouncing up or down).

Remove the cassette to reset the camcorder’s tracking to its preset center. The *TRACKING* buttons only affect tape playback. They have no effect during recording.

Playback on a TV or VCR with *AUDIO* and *VIDEO IN* Jacks

To connect your camcorder to a TV monitor (or VCR) with *AUDIO IN* and *VIDEO IN* jacks, you will need an optional audio/video cable, such as AH005 shown on page 54. If your TV is already connected to a VCR, you can attach the camcorder to the VCR and watch what the camcorder is recording or playing on the TV.

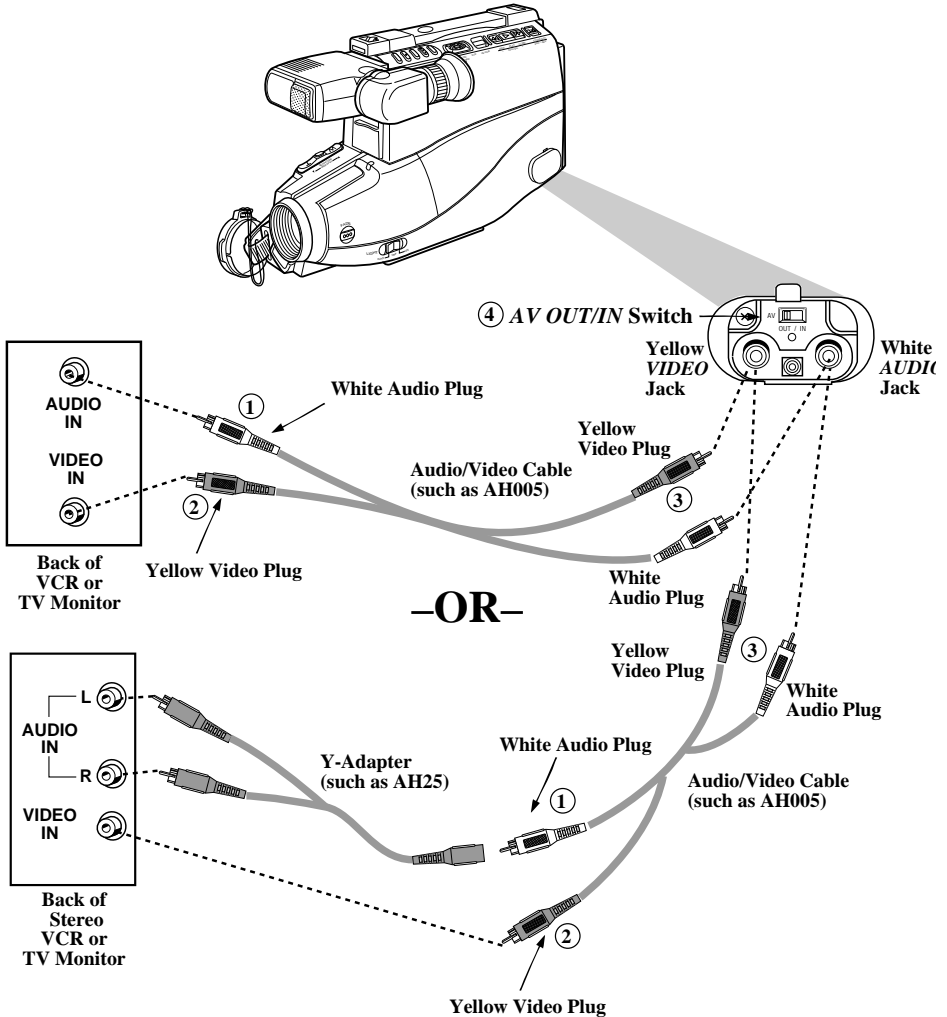

Caution: The unauthorized recording of television programs and other materials may infringe the rights of others.

Playback on a TV or VCR with *AUDIO* and *VIDEO IN* Jacks

- ① Attach the white plug on one end of the audio/video cable to the *AUDIO IN* jack on the TV or VCR.
Note: If your TV (or VCR) has stereo left and right *AUDIO IN* jacks, attach the plug to the one labeled *MONO*. If one of the jacks is not labeled *MONO*, you may need a Y-adaptor, such as AH25 shown on page 54, to hear both channels.
- ② Attach the yellow plug on the same end of the audio/video cable to the *VIDEO IN* jack on the TV or VCR.
- ③ Attach the yellow plug on the other end of the audio/video cable to the yellow *VIDEO* jack and the white plug to the white *AUDIO* jack on the side of the camcorder.
- ④ Place the *AV OUT/IN* switch to *OUT*.

Playback Operation and How to Copy Tapes on a VCR

1. A. Camcorder connected directly to TV monitor: Turn on the TV and tune it to its video input channel.
B. Camcorder connected to VCR that is already connected to TV: Turn on VCR and place it in the “line” or “camera” mode. (If your VCR does not have a “line” or “camera” mode, consult the VCR owner’s manual.) Operate the TV as you normally do to see the signal coming from the VCR.
2. Press and hold the small button on the camcorder’s *POWER* switch while sliding it to *VCR*. Insert the cassette you want to playback (or copy).
Note: The camcorder can only play back tapes recorded at the SP speed.
3. Press *PLAY* on the camcorder. To copy what the camcorder is playing, place a blank cassette in the VCR and start the VCR recording. Adjust the tracking on the camcorder if necessary. *Details are on page 43.*
 - During playback, use the playback features *described on page 43.*
4. Press *STOP/EJECT* when you are finished.

Watching What the Camcorder is Seeing or Recording on the TV

1. A. Camcorder connected directly to TV: Turn on the TV, and tune it to its video input channel.
B. Camcorder connected to VCR that is already connected to TV: Turn on VCR and place it in the “line” or “camera” mode. (If your VCR does not have a “line” or “camera” mode, consult the VCR owner’s manual.) Operate the TV as you normally do to see the signal coming from the VCR.
2. Press and hold the small button on the camcorder’s *POWER* switch while sliding it to *CAMERA*. Insert the cassette you want to record on.
Note: When the camcorder is used as a camera, turn the TV’s volume down to prevent a high-pitched squeal caused by feedback.
3. Press the camcorder’s *REC/PAUSE* button to begin recording. You can watch what the camcorder is seeing or recording on the TV screen.

Playback on a TV Without Audio and Video Inputs

To connect your camcorder to a TV without audio and video input jacks. You will need an optional RF output adapter (such as CRF95) and an optional coaxial RF cable (such as AH065G or AH066G) shown on page 54.

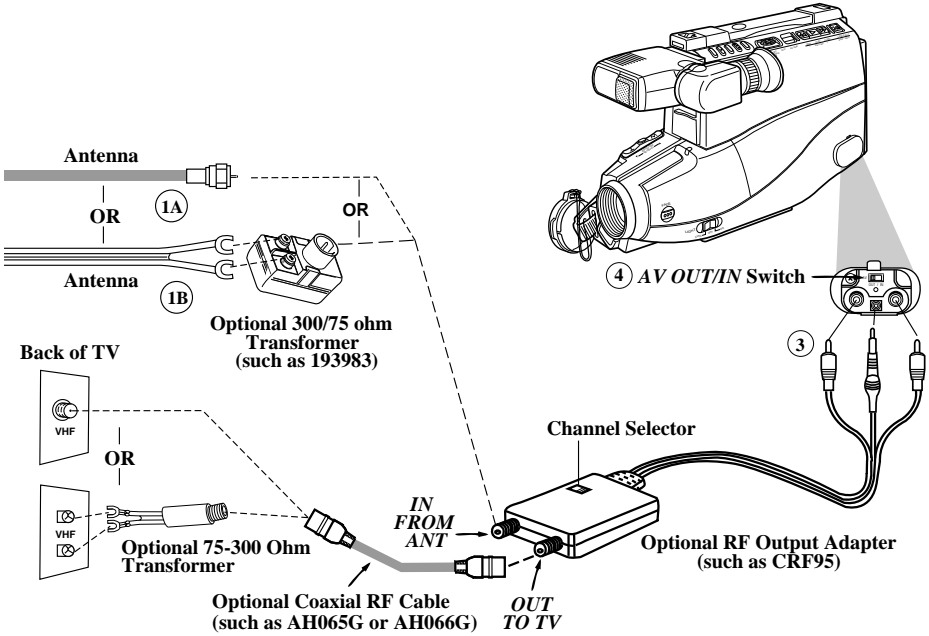

① Disconnect the VHF antenna from your TV. If you are going to leave the RF adapter connected to the TV, connect the antenna to the RF output adapter.

A. If antenna is round 75-ohm cable, connect it to *IN FROM ANT* connector on RF output adapter.

B. If antenna is flat twin-lead, connect flat-lead connectors to screw terminals on optional 300-75 ohm transformer. Then connect transformer to *IN FROM ANT* connector on RF output adapter.

② Attach one end of coaxial RF cable to *OUT TO TV* connector on RF adapter, and attach other end of the cable to VHF input on TV as shown.

Note: If TV has screw terminals, you may need an optional 75-to-300 ohm transformer, such as AH011.

③ Attach RF output adapter's yellow plug to the *VIDEO* jack, small plug to the *RF DC OUT* jack, and white plug to the *AUDIO* jack on the side of the camcorder.

④ Place the *AV OUT/IN* switch to *OUT*.

Playback on a TV Without Audio and Video Inputs

Playback Operation

1. Set the channel selector switch on the RF output adapter to *CH3* or *CH4*.
2. Turn on the TV and tune it to the same channel (3 or 4) you selected with the channel selector switch on the RF output adapter.
3. Press and hold the small button on the camcorder's *POWER* switch while sliding it to *VCR*.
4. Insert the cassette you want to play back into the camcorder.

Note: The camcorder can only play back tapes recorded at the SP speed.

5. Press *PLAY* on the camcorder. Adjust tracking on the camcorder, if necessary. *Details are on page 43.*
 - During playback, use the playback features *described on page 43.*
6. Press *STOP/EJECT* on the camcorder when you are finished playing back the tape.

Watch What the Camcorder is Seeing or Recording on the TV

1. Turn on the TV and tune it to channel 3 or 4 (the same channel you selected with the *CH3/CH4* switch on the RF output adapter).
2. Press and hold the small button on the camcorder's *POWER* switch while sliding it to *CAMERA*. Insert the cassette you want to record on.

3. Press the camcorder's *REC/PAUSE* button to begin recording. You can watch what the camcorder is seeing or recording on the TV screen.

Note: When the camcorder is used as a camera, turn the TV's volume down to prevent a high-pitched squeal caused by feedback.

Normal TV Viewing

For normal TV viewing, you can leave the RF output adapter hooked up to the TV. Just disconnect the adapter's plug

from the camcorder or turn the camcorder's power off.

Note to Cable-TV Installer: This reminder is provided to call your attention to Article 820-40 of the National Electrical Code (Section 54 of Canadian Electrical Code, Part I), that provides guidelines for proper grounding and, in particular, specifies that the cable ground shall be connected to the grounding system of the building as close to the point of cable entry as practical.

Color Enhancement Light

The color enhancement light helps create brighter, sharper pictures.

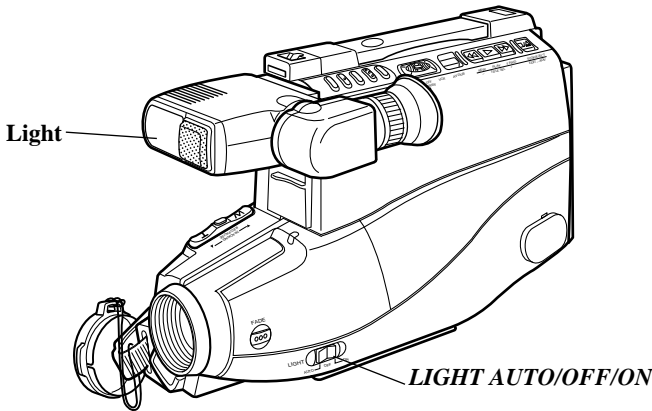

To Use the Color Enhancement Light

1. Attach the rechargeable battery or AC adapter/charger to power the camcorder.
2. Press and hold the small button on *POWER* and place it in *CAMERA*.
3. Select a position for the *LIGHT AUTO/OFF/ON* switch.
 - Place in *AUTO* to have the light automatically turn on when the camcorder is aimed at a dark object and turn off when aimed at a bright object.

Note: A cassette must be inserted for *AUTO* to operate.

- Place in *ON* to have the light turn on whenever *POWER* is in *CAMERA*.
- Place in *OFF* to turn off the light.

If the camcorder is left in record pause for more than five minutes, the power and light automatically turn off. Press *REC/PAUSE* to turn camcorder back on.

Notes: Turn on the light only when you need it. The power consumption of the light is approximately two-thirds that of the camcorder. When the light is on, the operation time of the rechargeable battery is reduced.

Avoid bumping or shaking the light when in use. The light's bulb is sensitive when hot and may burn out.

Do not allow water to drop on the light when in operation.

Dangers: During operation and after using the light, the front surface and bulb of the light will be very hot. To avoid burns, do not touch them.

To prevent overheating, do not block or cover the ventilation holes on the color enhancement light.

Never use the color enhancement light in the vicinity of explosives or highly flammable materials.

Color Enhancement Light

Removing and Replacing the Front Case of the Light

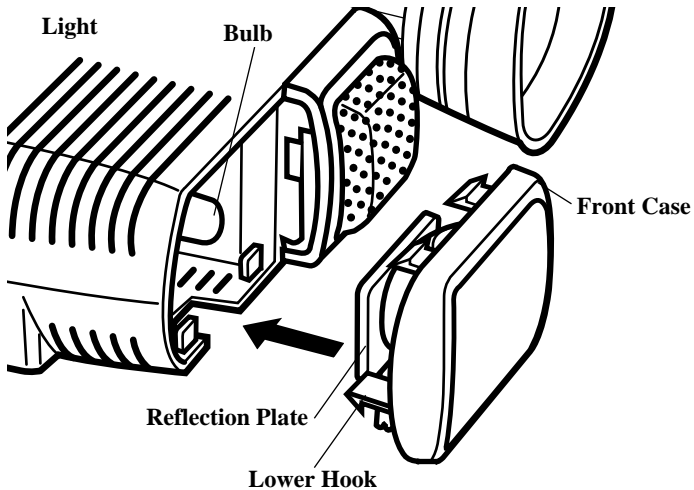

To Remove and Replace Light Case

1. To remove front case, press and hold the lower hook while removing it.
2. To replace the front case, pass the bulb through the hole of the reflection plate, and attach the lower hook to the light.
3. Press front of case to light.

Notes: Do not touch the bulb with your fingers. It may shorten its service life.

Make sure the front case of the light is properly attached after removing it or replacing a bulb.

When replacing the bulb, only use #221111 to reduce the risk of fire and other hazards.

See the installation instructions packed with the replacement bulb when replacing the bulb.

Caution: Use only bulb #221111 when replacing the bulb to reduce the risk of fire or other hazards.

Attaching the Shoulder Strap

The shoulder strap is designed to let you carry the camcorder from your shoulder and — when you are ready to shoot — bring the camcorder to shooting position in one quick movement.

Cautions: When carrying the camcorder with the shoulder strap, place the viewfinder in its original position. This helps prevent possible damage to the viewfinder from bumping against your body as you move.

Make sure the shoulder strap is firmly attached before using it to carry your camcorder.

To Attach the Shoulder Strap

1. Unfasten one end of the shoulder strap from the buckle. Make sure you leave the buckle on the strap.



2. Thread one end of the shoulder strap through one of the shoulder strap rings as shown below in diagrams A and B.

Diagram A

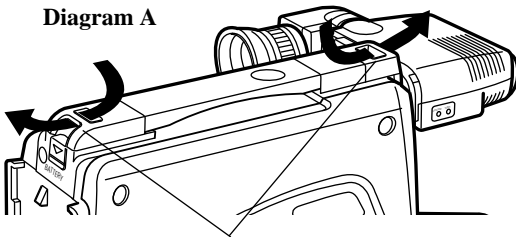
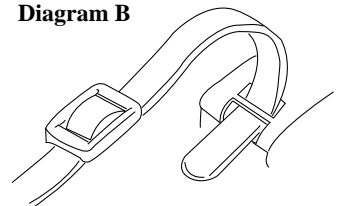
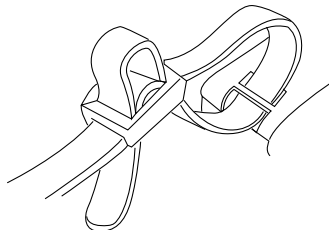

Diagram B



Shoulder Strap Rings

3. Thread the strap back into the buckle as shown below. Pull on the strap and make sure it is fastened correctly and tightly before using it to support your camcorder.



4. Repeat steps 1–3 to attach the other end of the shoulder strap.

Packing Carrying Case

The carrying case that came with your camcorder is specially designed to provide protection for your camcorder and its accessories. See below for details on packing your case.

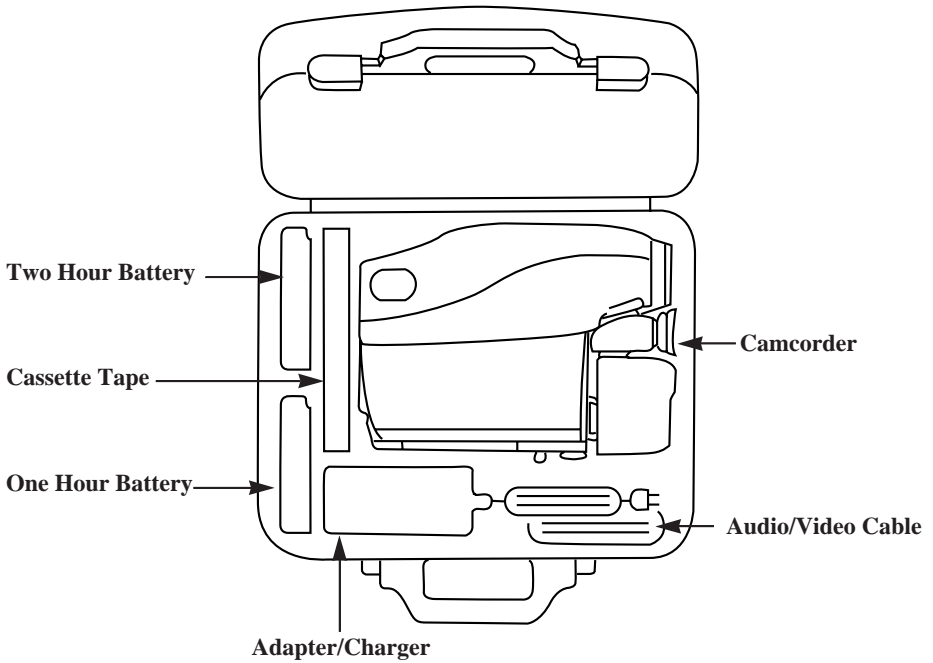

Optional Accessories

We invite you to take a look at some great ideas for sparking creativity and adding to the fun of using your camcorder. These pages have a selection of accessories to help make your memorable moments look and sound even better.

To order accessories, contact your local dealer.

Accessories are available by calling toll-free or by using the order form on page 57.

AC028A Soft Camcorder Case

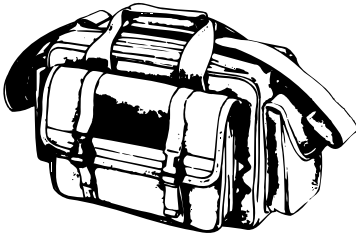

This case provides exceptional protection and utility for full size camcorders and most accessories. It is constructed of rugged, 1000 denier weight, Cordura nylon fabric for years of reliable service and good looks.

Three outside pockets provide ample accessory storage with mesh-covered lens filter compartment and built-in holders for memo pads, pens, and other accessories. The hand grip and adjustable shoulder strap allow for convenient, comfortable transportation of the camcorder.

VCC1000 Video Color Control Center

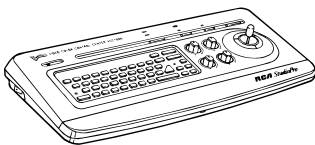

The VCC1000 is two accessories in one. The color control center allows you to adjust the color intensity, tint, white balance, and sharpness of tapes being dubbed. This is especially helpful when the original tape was produced in poor lighting conditions or poor color settings.

The second feature, the character generator, lets you create titles that can be recorded on your tapes. This lets you add a professional and/or personal touch to your home videos.

All specifications and descriptions of accessories are subject to change without notice.

Optional Accessories

DCC096 DC (Battery) Car Cord

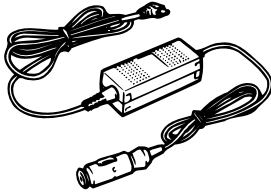

This DC car cord enables you to operate your camcorder from your car, truck, or RV by plugging the car cord directly into the vehicle's cigarette lighter.

Caution: Do not use any other car cord with this camcorder.

CPS014 AC Adapter/Charger

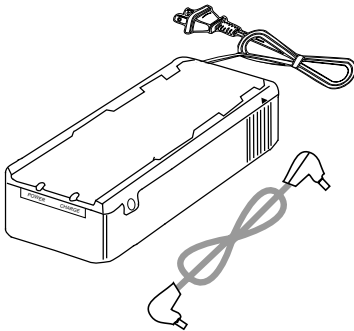

This adapter/charger operates on 100-240 volts, 50/60 Hz, so it can be used almost anywhere in the world to power your camcorder and recharge the EP096FS battery supplied with your camcorder.

It also charges the EP096FL (2 hour) battery. A simple plug adapter may be required in some countries.

EP096FS and EP096FL Rechargeable Batteries

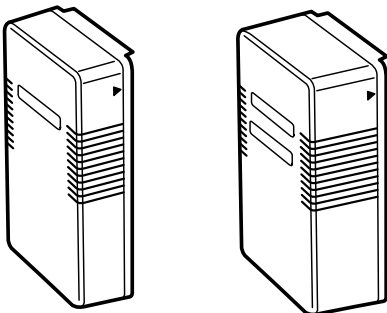

These rechargeable lead-acid batteries are specifically designed for long life. The EP096FS can power your camcorder up to one hour and the EP096FL up to two hours (depending on how much you use the light, zoom, and pause).

Both batteries can be recharged with the AC adapter/charger that came packed with your camcorder. First charging takes approximately two hours for the EP096FS and three hours for the EP096FL.

(continued on next page)

Optional Accessories

AH005 Audio/Video Cable

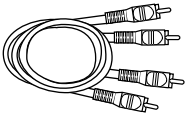

This six foot audio/video dubbing cable is used to connect your camcorder to a VCR or TV monitor to copy tapes.

CRF95 RF Output Adapter

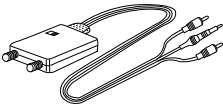

This adapter is used with coaxial RF cable (AH065G or AH066G) to connect your camcorder to a standard TV (one without audio/video input jacks) for playback. If your antenna cable is the flat twin-lead type attached by two screws, you will also need a 300-75 ohm transformer such as 193983. If your TV has 300 ohm VHS screw terminals, you will need an optional 75/300 ohm transformer such as AH011.

Coaxial RF Cables

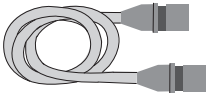

AH065G (6-ft)

AH066G (10-ft)

These RF cables are used with the RF output adapter to connect your camcorder to a standard TV (one without audio/video input jacks) for playback.

If your antenna cable is the flat twin-lead type attached by two screws, you will also need a 300-75 ohm transformer such as 193983.

If your TV has 300 ohm VHS screw terminals, you will need an optional 75-300 ohm transformer such as AH011.

193983 Cable Transformer

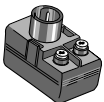

This 300-to-75 ohm transformer is used to connect a standard 300-ohm antenna twin-lead to a standard round 75-ohm connector.

AH011 Cable Transformer

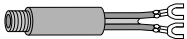

This 75-to-300 ohm transformer is used to connect a standard 75-ohm antenna cable, such as AH065G or AH066G, to the 300-ohm screw terminals on a TV.

AH25 Y-Adapter



This Y-adapter allows you to connect your camcorder's mono audio cable to a stereo TV or VCR.

Optional Accessories

Removing the Lens Hood

The lens hood can be removed so you can attach optional accessories, such as wide-angle lens, lens extender, or lens filter kit.

To remove the lens hood, place your hand flat against the lens hood and turn it counterclockwise. Do not grasp the end of the lens hood.

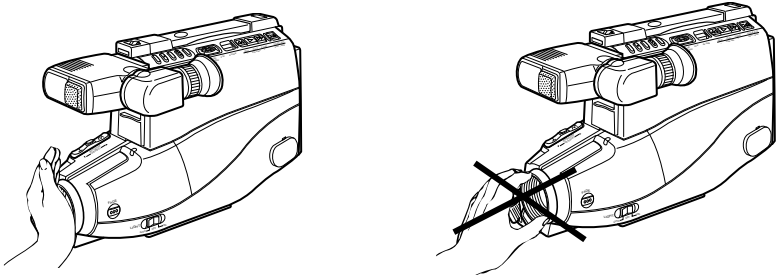

Attaching Accessory Lens

Remove the lens hood *as shown above*.

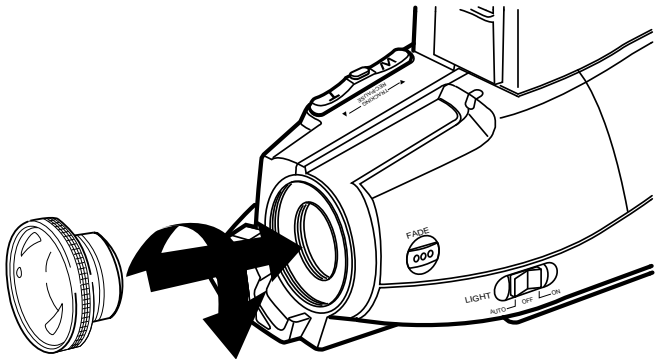

Turn the accessory lens clockwise into the camcorder's lens. Make sure the lens is tightened firmly, but do not over tighten.

All specifications and descriptions of accessories are subject to change without notice.

(continued on next page)

Optional Accessories

Using an Optional Tripod

Mounting the camcorder on a tripod, such as AC031 or AC040, will keep the camcorder steady and produce excellent video results.

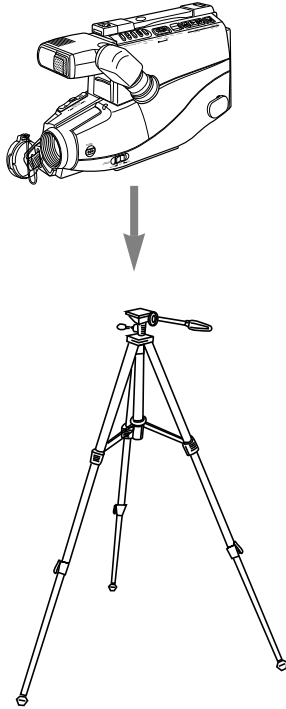

AC031 Deluxe Tripod

This tripod's fluid effect head provides smooth camera pan and tilt. Its quick-release mount makes it easy to attach or remove the camcorder. The grooved, tubular 3-section leg design folds down to 24" when not in use and weighs only 4-1/4 lbs. Rubber feet allow for sure footing and the built-in retractable leg spikes eliminate the need for removing the feet.

AC040 Heavy Duty Tripod

This high-end tripod is equipped with many professional features that enable you to produce professional results. The spring-flow head system combines both fluid and spring action for smooth "panning" and tilt action. It features heavy-duty 30 mm "D-channel" styled legs, oversized quick-release pad, click stop tilt adjustment, pan-drag tension adjustment, tilt-lever lock, transferable handle, bubble level, adjustable elevator friction tube, non-skid rubber feet with retractable spikes and quick-release leg lever locks.

Caution: Before using a tripod, make sure it is stable enough to hold the camcorder without falling over. Do not transport the camcorder attached to the tripod.

When attaching your camcorder to a tripod, be careful not to force the tripod screw into the camcorder's tripod mounting hole.

The tripod screw should not protrude into the camcorder more than approximately three-eighth (3/8) inch. Forcing the screw could damage the mounting hole on the bottom of the camcorder.

All specifications and descriptions of accessories are subject to change without notice.

Accessory Order Form

Order Form for Camcorder Models CC423

Description	Part No.	Price	Qty.	Total
Soft Camcorder Case	AC028A	\$ 89.95		
Deluxe Tripod	AC031	\$ 99.95		
Heavy Duty Tripod	AC040	\$169.95		
Audio/Video Cable	AH005	\$ 10.99		
Cable Transformer	AH011	\$ 1.90		
RF Coaxial Cable (6-ft.)	AH065G	\$ 6.99		
RF Coaxial Cable (10-ft.)	AH066G	\$ 8.99		
Y-Adapter	AH25	\$ 1.95		
Rechargeable Battery	EP096FS	\$ 74.95		
Rechargeable Battery	EP096FL	\$ 89.95		
AC Adapter/Charger	CPS014	\$179.95		
RF Output Adapter	CRF95	\$ 49.95		
Car Cord	DCC096	\$ 49.95		
Video Color Control Center	VCC1000	\$349.00		
300-75 Cable Transformer	193983	\$ 6.95		
DC Cable	209342	\$ 12.95		
Shoulder Strap	227327	\$ 13.95		
Replacement Bulb (4 watt) for Built-in Light	221111	\$ 12.95		
AC Adapter/Charger (Supplied)	221355 or 221356	\$169.95		

Prices are subject to change without notice.

Total Merchandise (\$10 Minimum Order)..... \$ _____

Sales Tax \$ _____

We are required by law to collect the appropriate sales tax for each individual state, county, and locality to which the merchandise is being sent.

Shipping, Handling, and Insurance \$ _____ 5.00

Total Amount Enclosed \$ _____

Use VISA or MasterCard preferably. Money order or check must be in U.S. currency only. No COD or cash.

- Allow 8 weeks for delivery.
- All accessories are subject to availability.

Detach Here



Please complete other side also

Accessory Order Form

Charge your order on your VISA
or MasterCard by
filling in below

USE YOUR CREDIT CARD

IMPORTANT: Copy complete account number
from your VISA card



My card expires:

IMPORTANT: Copy complete account number
from your MasterCard



Copy Number above your name on MasterCard My card expires:

AUTHORIZED SIGNATURE

Prices are subject to change without notice.

Print or type your name and address clearly. This will be your mailing label.



A complete and correct order will save you days of waiting.

Name: _____

Street: _____

_____ Apt: _____

City: _____

State: _____ Zip: _____

Please make sure that both sides of this form have been filled out completely.

Detach Here 

Accessory Order Form

To order accessories, contact your local Dealer.

If a dealer is not nearby, you can also follow the directions below to order by telephone or direct-by-mail.

United States and Canada Orders

To place your order by phone, have your Visa or MasterCard ready and call the toll-free number listed below between 8AM and 8PM Eastern Standard Time. **Use this number only to place an order for accessory items listed on this order form.**

1 – 800 – 338 – 0376

Most times your order will be shipped UPS within 72 hours of receipt. If ever it is not possible to ship within 30 days, we will notify you with an update on your order and an option to cancel.

To place your order by mail, detach and mail the completed order form with credit card information, money order, or check in U.S. currency (made payable to Thomson Consumer Electronics, Inc.) to the following address:

Video Accessories
PO Box 8419
Ronks, PA 17573

For more information on these accessories (or current prices), write to the following address:

Video Accessories Customer Service
Thomson Consumer Electronics, Inc.
Distributor & Special Products
2000 Clements Bridge Rd
Deptford, NJ 08096-2088

International Orders

This offer is valid only in the United States and Canada. For international orders, please send your request for a price quotation (not an order) to:

International Customer Service
Thomson Consumer Electronics, Inc.
Distributor & Special Products
2000 Clements Bridge Rd
Deptford, NJ USA 08096-2088

Care and Maintenance

Keep dust and grit from entering the camcorder's cassette door. Dust and grit are abrasive and cause excessive wear to both the camcorder's recording and playback heads and cassettes.

Do not use strong or abrasive detergents when cleaning your camcorder. They may damage the camcorder.

Before handling your camcorder, make sure your hands and face are free from any chemical products such as suntan lotion, as it may damage the finish.

Do not touch the lens with your fingers! The oil from your skin may damage the lens. To clean the lens, always use lens-cleaning tissues and a commercially prepared cleaning solution designed for use on camera lens.

Always replace the lens cap on the lens when the camcorder is not in use.

The camcorder can be damaged by improper storage or handling. Do not subject the camcorder to swinging, shaking, or dropping.

Do not store the camcorder in temperatures below -22°F (-30°C) or above 149°F (65°C).

When the camcorder is not in use, always remove the cassette and AC adapter/charger or battery.

Retain the original carton for future storage or shipping purposes.

Things to Avoid

Do not aim your camcorder at the sun or other bright objects or leave your camcorder in direct sunlight. Doing so could permanently damage the camcorder's internal parts.

Avoid operating your camcorder after moving it from a cold location to a warm location. Moisture may cause the tape to stick to the headwheel and damage the headwheel or tape. Give the camcorder 2 to 3 hours to reach a stable temperature before inserting a cassette.

Do not operate or leave your camcorder in extremely humid environments.

Do not operate the camcorder for extended periods in temperatures below 40°F (4°C) or above 95°F (35°C).

Do not expose the camcorder or adapter/charger to rain or moisture. If either component becomes wet, turn off the power and take the unit to an Authorized RCA Camcorder Servicer.

Care and Maintenance

Cleaning the Camcorder

To clean the camcorder's exterior, remove any power source connected to the camcorder and gently wipe it with a clean soft cloth.

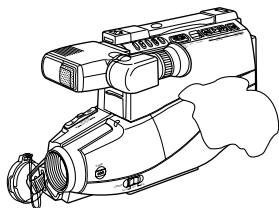

Caution: Use of strong cleaning products, such as those containing alcohol or benzine, may damage the camcorder.

Cleaning the Camcorder's Lens

To clean the camcorder's lens, blow it with a blower brush, and then gently wipe the lens with cleaning tissue and commercially prepared cleaning solution designed for use on camera lens. Improper cleaning may scratch the lens.

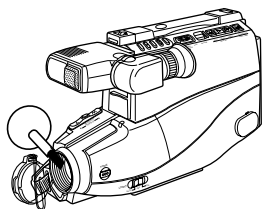

Caution: Do not touch the lens with your fingers. The oil from your skin can damage the lens.

Cleaning the Camcorder's Viewfinder

The viewfinder eyepiece can be removed for cleaning.



1. Turn the eyepiece counterclockwise and pull it out.



2. Gently use a cotton swab or blower brush to remove dust.



3. Reattach the eyepiece by aligning the reference marks, and then turn the eyepiece clockwise.

Trouble Checks

Troubles sometimes are caused by simple “faults” that you can easily correct without the help of a service technician by first checking a few basic remedies.

Before you call or take your camcorder to an Authorized RCA Camcorder Servicenter, look below for the type of trouble you are experiencing. Then perform the simple checks and adjustments listed for that trouble.

Trouble	Checks and Adjustments
No Power (<i>POWER</i> Indicator Will Not Come On)	<ul style="list-style-type: none">• If using the rechargeable battery, it may need recharging.• If using the AC adapter/charger, make sure it is plugged into a working AC outlet.
Will Not Record or Play Back	<ul style="list-style-type: none">• Make sure there is a cassette in the camcorder.• Try ejecting and re-inserting the cassette.• The cassette tape is broken — try another cassette.• You have reached the end of the cassette — try rewinding it.• Moisture condensation may cause the tape to stick to the headwheel and damage the headwheel or tape. Give the camcorder 2 to 3 hours to reach a stable temperature before re-inserting a cassette.
Will Not Play Back	<ul style="list-style-type: none">• <i>POWER</i> switch must be in <i>VCR</i>.
Will Not Record	<ul style="list-style-type: none">• Safety tab has been removed from cassette. <i>See page 16.</i>• <i>POWER</i> switch must be in <i>CAMERA</i>.• <i>AV OUT/IN</i> switch must be in <i>OUT</i> to record on the camcorder.
No Picture in Viewfinder	<ul style="list-style-type: none">• Make sure the lens cap has been removed.
Tape Does Not Rewind or Fast Forward	<ul style="list-style-type: none">• Make sure titler graphics do not appear in viewfinder. Press <i>TITLER</i> to remove them.

Trouble Checks

Trouble	Checks and Adjustments
Tape Stops During Rewind or Fast Forward	<ul style="list-style-type: none"> • The tape counter's memory-stop feature may be turned on. When an "M" appears behind the tape-counter display, the camcorder will stop rewinding or fast-forwarding when the counter reads "0000M". Press the <i>REW</i> (rewind) or <i>F.FWD</i> (fast forward) button again to continue, or press <i>DISPLAY</i> to turn off memory stop.
Camcorder Remains in Play Pause	<ul style="list-style-type: none"> • Press <i>REC/PAUSE</i> to return to normal playback.
Poor Picture Quality During Recording	<ul style="list-style-type: none"> • There is insufficient light. Add more light. • Use the color enhancement light to add more light. <i>Details are on pages 48-49.</i>
Viewfinder Displays Are Out of Focus	<ul style="list-style-type: none"> • Try adjusting the eyepiece focus control. <i>Details are on page 22.</i>
Poor Auto-Focus Operation	<ul style="list-style-type: none"> • Lens may be smudged and image appears unfocused. • Viewfinder eyepiece focus or <i>BRIGHT</i> control may be adjusted incorrectly. <i>Details are on pages 22-23.</i>
Poor Picture Quality During Playback	<ul style="list-style-type: none"> • Tape was recorded on a different camcorder or VCR. If the picture contains black-and-white streaks, press one of the <i>TRACKING</i> buttons to correct. • Camcorder only has one speed (SP). If the tape was recorded on a different VCR at a different speed, it cannot be played back in this camcorder.
Recorded Audio is Too Low	<ul style="list-style-type: none"> • Subject may have been too far from the camcorder.

(continued on next page)

Trouble Checks

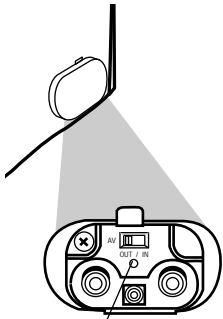
Trouble	Checks and Adjustments
AE Shutter-Speed or INDEX Indicator Does Not Appear in Viewfinder	<ul style="list-style-type: none"> • <i>POWER</i> switch must be in <i>CAMERA</i>.
Date and Time (or Date) were Recorded on the Tape	<ul style="list-style-type: none"> • Date and time (or date) will be recorded on the tape whenever they appear in the viewfinder. Press <i>DATE/TIME</i> to remove them from the viewfinder when recording.
Color in Viewfinder Does Not Look Natural and needs Adjustment	<ul style="list-style-type: none"> • The <i>COLOR</i> and <i>TINT</i> controls may need adjustment. Caution: Use a plastic screw driver to carefully adjust these delicate controls.
Date and Time Appear Incorrect	<ul style="list-style-type: none"> • Make sure the date and time have been set. <i>Details on page 26.</i> • The camcorder's internal clock battery may need recharging. <i>Details on page 27.</i>
Camcorder Does Not Turn On and/or Function Buttons Will Not Operate	<ul style="list-style-type: none"> • Remove the power source. After one minute press the reset switch gently using a non-metallic pointed item, such as a toothpick, until you feel a click. This resets the camcorder to the factory settings and erases the date, time, and custom settings. <div data-bbox="753 799 974 1150" style="text-align: right;">  <p>Reset Switch</p> </div>

You can reach Thomson at the following number:

800-283-6503
(Toll free inside U.S.A.)

Our toll-free Camcorder number operates from 8 a.m. to 5 p.m., CST Monday – Friday for U.S. customers only

Thomson provides a toll-free telephone number to help you with any problems you may encounter with your camcorder. Many can be diagnosed over the phone, and if necessary, a replacement unit can be shipped to you. Please have your camcorder model/serial number and date of purchase ready when you call. If your unit is out of warranty, we will quote the cost of an exchange unit to you.

Returning equipment to Thomson for repair or exchange

If we are unable to resolve your problem over the phone, we will gladly service your unit or exchange it for a new or refurbished camcorder. Refer to the limited warranty on the reverse side to learn about your specific rights and responsibilities.

Always consult Thomson and get a Return Authorization number before returning anything! Obtain a Return Authorization (RA) number from the telephone representative before returning your equipment to avoid delays, accounting errors, or even loss of your unit.

Important information to customers who ship defective equipment to Thomson Consumer Electronics

The Thomson representative who authorized the return of your equipment will give you an RA number over the phone. They will also provide you with instructions on where and how to return your camcorder. Write the number in large, clear characters on the outside of the box. To avoid confusion and misunderstandings, shipments without an RA number clearly visible on the outside of the box will be returned to you at your expense.

Include a brief note describing the problem and any conversations about the problem you have had with Thomson personnel. Include your name, address

and model/serial number of your camcorder. These numbers are located on the bottom of your unit. If your camcorder is within the warranty period, please provide a copy of the bill of sale to verify purchase date. Use the original box and packing material to protect the equipment from damage in shipment.

For your protection, insure all shipments for full replacement value and use a reliable shipper. Thomson assumes no responsibility for warranty shipments from the customer to the factory if not shipped in the manner prescribed by Thomson.

Limited Warranty

What your warranty covers:

- Any defect in materials or workmanship.

For how long after your purchase:

- 90 days for labor charges.
- One year for parts.

What we will do:

During the initial 90 days

- Exchange your camcorder with a new or, at our option, a refurbished unit or at your option, repair your camcorder at no cost to you.

After the 90 days and within one year

- Exchange your camcorder with a new or, at our option, a refurbished unit or at your option, repair your camcorder. Parts will be provided at no charge, but you will be responsible for the cost of labor required for the repair.

How you get service:

- Call 1-800-283-6503 and have your unit's date of purchase and model/serial number ready. The model/serial number information is on the bottom of your camcorder.
- A representative will troubleshoot your problem over the phone. If the representative determines that you should receive a replacement unit, you will be provided with a Return Authorization (RA) number and the location of a nearby exchange point if one exists. No returns will be accepted without the RA number.

To receive a replacement camcorder before you return yours:

If you are located near an exchange point:

1. We will send a replacement unit to the exchange point next business day delivery.
2. The exchange location will notify you of its arrival.
3. Take your unit, including all accessories, and your bill of sale

which validates date of purchase to the exchange location and you will be provided the new or refurbished unit.

4. If the repairs were covered by your warranty, you will not be billed.

If you are not located near an exchange point:

1. Provide your Discover, MasterCard or Visa account number and expiration date to our phone representative. This is for security purposes. If we receive your unit including all accessories within 14 days from the date you were provided a Return Authorization number, only items not covered by warranty will be charged to your account. **IF YOUR UNIT INCLUDING ALL ACCESSORIES IS NOT RECEIVED WITHIN 14 DAYS, THE SUGGESTED RETAIL VALUE OF THE CAMCORDER AND/OR ACCESSORIES WILL BE CHARGED TO YOUR CREDIT CARD.** This amount will be credited if the unit is subsequently received.
2. We will send you a replacement unit next business day delivery.
3. You will receive an invoice packed with the replacement product, but will not be charged for the unit portion of the invoice amount if we receive your unit including all accessories within 14 days from the date you were provided the RA number. Any labor and parts charges not covered by our warranty will be included and charged against your account.
4. Ship the unit back to us along with all accessories included with your camcorder using the replacement unit's carton. Shipping instructions will be included in the carton along with your RA number, which will allow you to easily ship the unit back to us. **Make sure you insure your**

Limited Warranty

shipment in case of damage or loss.

Include with the shipment:

- A copy of your dated bill of sale to verify your unit's warranty eligibility.
- A brief note describing your camcorder problem.
- Your name, address and phone number.

Return transportation, storage, and handling costs and insurance are your sole responsibility. We accept no liability in case of damage or loss.

To receive a replacement unit after we have received your unit:

1. Write the RA number on the outside of the carton used to return the unit.

Make sure you insure your shipment in case of damage or loss.

2. Carefully pack the unit along with all accessories included with your camcorder, using the original box and packing material if possible.
3. Include with the shipment:
 - A copy of your dated bill of sale to verify your unit's warranty eligibility.
 - A brief note describing your camcorder problem.
 - Your name, address and phone number.

Return transportation, storage, and handling costs, and insurance are your responsibility. We accept no liability in case of damage or loss.

4. Include a cashier's check or money order for payment if there are any out of warranty labor or parts charges which were indicated by the representative, and you elected not to use your credit card.
5. Upon receipt of your product, a new or refurbished unit will be shipped to you next day delivery.

To have your Camcorder repaired by an Authorized RCA Camcorder Servicenter:

- Check with your dealer or call 1-800-336-1900 for the Authorized RCA Camcorder Servicenter nearest you.
- Take your unit to the Authorized RCA Camcorder Servicenter of your choice.
- Show the Authorized RCA Camcorder Servicenter representative your sales receipt or other, evidence of purchase.
- Pick up your camcorder when repairs are complete.

What your warranty does not cover:

- Adjustment of customer controls.
- Damage from misuse or neglect.
- A unit that has been modified or incorporated into other products or is used for institutional or other commercial purposes.
- Battery for clock and other features.
- Cleaning of video/audio heads.
- Camcorders purchased or serviced outside the U.S.A.
- Return transportation, storage and handling costs of your unit, including insurance for loss or damage.
- Acts of God, such as but not limited to lightning damage.

Product Registration:

- Please complete and mail the *Product Registration Card* packed with your camcorder. It will make it easier to contact you should it ever be necessary. The return of the card is not required for warranty coverage.

How State Law relates to warranty:

- This warranty gives you specific legal rights and you may have other rights that vary from state to state.

If you purchased your Camcorder outside the United States:

- This warranty does not apply. Contact your dealer for warranty information.

Specifications

General

Power requirement: 9.6VDC

Power consumption: 8 watts (normal)

Weight: 4.4 lbs. (2 kg)

Dimensions:

4-1/2"(W) x 8-1/8"(H) x 12-1/4"(D)

(111 x 205 x 311mm)

Video Recorder Section

Format: VHS

Record/Playback System:

Two video record/playback heads

One flying erase head

Headwheel Cylinder Diameter: 62 mm

Video Signal: EIA Standard NTSC

Color

Camera Section

Scanning: 525 Lines/60 Fields/30

Frames

Image Sensor: 1/4" high/resolution,
solid state CCD imager

Tripod Mount: One 1/4" x 20 threaded
hole

Lens: f1.6 — 12:1 (4-48mm)

Diameter: 46 mm

Adapter/Charger

Power Requirement: 120 V 50/60 Hz

Power Consumption: 30 Watts (max)

Weight: (390 grams)

Dimensions:

(78 x 52 x 155 mm)

Tripod Mount: One 1

Information to User

This equipment has been tested and found to comply with the limits for a Class B digital device and RF lighting device, pursuant to Part 15 and part 18 of the FCC Rules. These limits are designed to provide reasonable protection against harmful interference in a residential installation. This equipment generates, uses, and can radiate radio frequency energy and, if not installed and used in accordance with the instructions, may cause harmful interference to radio communications. However, there is no guarantee that interference will not occur in a particular installation. If this equipment does cause harmful interference to radio or television reception, which can be determined by turning the equipment off and on, the user is encouraged to try to correct the interference by one or more of the following measures:

- Reorient or relocate the receiving antenna.
- Increase the separation between the equipment and receiver.

- Connect the equipment into an outlet on a circuit different from that to which the receiver is connected.
- Consult the dealer or an experienced radio/TV technician for help.

Alterations or modifications carried out without appropriate authorization may invalidate the user's FCC right to operate the equipment.

This digital apparatus does not exceed the Class B limits for radio noise emissions from digital apparatus as set out in the interference-causing equipment standard entitled "Digital Apparatus", ICES-003 of the Department of Communications.

Cet appareil numérique respecte les limites de bruits radioélectriques applicables aux appareils numériques de Classe B prescrites dans la norme sur le matériel brouilleur: "Appareils Numériques", NMB-003 édictée par le ministre des Communications.

— A —

A. (Audio) *DUB* Indicator24,33,35
A/V DUB Indicator24,35
 Accessories, Included3
 Accessories, Optional52-59
 Accessory Lens, Attaching55
 Accessory Order Form57-59
 Adapter/Charger, Using4,10
 Adjustments and Checks62-64
AE Displays20,24
 AI (Artificial Intelligence)19
 Assistance65
 Attaching the Adapter/Charger . . .4,10
 Attaching the Rechargeable Battery .12
 Attaching the Shoulder Strap50
 Audio Dubbing32-33
 Audio/Video Dubbing33,35
AUDIO/VIDEO Jacks
8,32-33,34-35,40-41,44-45,46
AUTO Date Display27
AV (Audio/Video) *OUT/IN* Switch
8,32-33,34-35,40-41,44-45,46
AV DUB Button8,25,33,35

— B —

Battery, Attaching and Removing . . .12
 Battery Care and Storage13
 Battery Charging11
 Battery, Clock27
BATTERY EJECT Lever8,12
 Battery Level Indicator14,24-25
 Battery, Rechargeable11-14
 Battery Safety Precautions13
BRIGHT Control9,23
 Bulb Replacement, Video Light49

— C —

Camcorder, Cleaning61
 Camcorder Operating Controls8-9
 Camcorder, Powering10-15
 Camcorder, Recording On From a
 VCR or *TV* Monitor40-41
 Camcorder, Unpacking3
CAMERA/OFF/VCR Switch . .5,7,12,19,
 26-27,33,35,36-38,41,42,45,47
 Car Cord, Optional15,53
 Card, Registrationi
 Care and Maintenance60-61
 Care and Storage, Battery13
 Care and Storage, Cassettes17
 Carrying Case, Packing51
 Cassette Door9,17
 Cassette, Inserting and Removing .6,17
 Cassette Tips18
 Cassettes, Video16-17
 Charging the Battery11
 Chart of Title Characters37
 Checking Battery Power14
 Checks and Adjustments62-64
 Cleaning the Camcorder61
 Clock Battery, Charging27
COLOR Control9,23
 Color Enhancement Light48-49
 Contents1-2
 Copying Tapes40-41,44-45
 Correcting the Date and Time26
 Customer Assistance .1,3,65,Back Cover

Index

— D —

Date and Time Displays . . .24-25,26-27
Date and Time Recording27
DATE/TIME Button8,25,26-27
DC IN 9.6V Jack9
Design Specifications68
DISPLAY Button8,24-25,30
Dubbing32-33,34-35

— E —

Edit Search31
EDIT—ADV Button8,36-38
Electronic Indexing21
Erase Protection16
Eyepiece Focus Control6,8,22

— F —

F.FWD Button . .8,19,26,30,31,33,35,43
FADE Button8,24,29
FADE Indicators24,29
Fading29
First-Time Operation3-9
Flying Erase Head31
Focus, Auto and Macro20

— H —

Handstrap5,9

— I —

INDEX Indicator21,24-25
Indexing, Electronic21
Information to User69

— L —

Lens Hood8,55
Lens Cap Holder9
Lens Cap, Remove5
Lens Hood, Removing55
Lens, Cleaning61
LIGHT AUTO/OFF/ON Switch . . .8,48
Light Bulb, Replacing49
Light, Built-in8,48-49
Limited Warranty66-67

— M —

Maintenance and Care60-61
Memory Stop Feature30
Microphone8,19

— N —

NO TAPE Indicator24-25

— O —

OFF/CAMERA/VCR Switch . .5,7,12,19,
.26-27,33,35,36-38,41,42,45,47
Operating Controls, Camcorder8-9
Operation, First-Time3-9
Optional Accessories52-59
Optional Car Cord15,53
Order Form, Accessories57-59

Index

— P —

- Packing Carry Case 51
- PAUSE* Indicator 33,35
- Picture Search 43
- PLAY* Button 7,8,31,33,35,42,45,47
- Playback on a TV with
 - AUDIO/VIDEO IN* Jacks 44-45
- Playback on a TV
 - without Audio/Video Inputs 46-47
- Playback, First 7
- Playback, Viewfinder 42
- Plug Adapter, Optional 10
- POWER (CAMERA/OFF/VCR)*
 - Switch 5,7,12,19,26-27
 - 33,35,36-38,41,42,45,47
- Power Zoom Buttons 24-25,28
- Powering Your Camcorder 10-15
- Problem Solving 62-64
- Product Registration i
- ProEdit Features 31-38
- Program AE (Auto Exposure) 20

— Q —

- Quick Review 19

— R —

- REC* Indicator 7,24
- REC/PAUSE* Button
 - 7,9,29,30,33,35,38,43,45,47
- Rechargeable Battery 11-14
- Recording Date and Time 27
- Recording on the Camcorder 40-41
- Recording Speed 16
- Recording Tips 39
- Recording Titles 38

- Recording, First 7
- Registration Card i
- Removing Lens Hood 55
- Removing the Rechargeable Battery 12
- Replacing Bulb of Video Light 49
- RESET* Button 8,30
- REVIEW* Button 8,19
- REW* (Rewind) Button
 - 7,8,19,26,30,31,33,35,43
- RF DC OUT* Jack 8,46
- RF Output Adapter 46-47,54

— S —

- Safety Information i
- Safety Precautions, Battery 13
- Safety Tab 16
- Set the Date and Time 26
- Shoulder Strap Attachment Rings 9,50
- Shoulder Strap, Attaching 50
- Solving Problems 62-64
- SP (Standard Play) Speed 16
- Specifications 68
- Status Displays 24
- Stop Action Pause 43
- STOP/EJECT* Button
 - 6,7,8,17,19,26,30,33,35,45,47

— T —

- Tab, Safety 16
- Table of Contents 1-2
- Tape Copying 40-41,44-45
- Tape Counter 24,30
- TAPE END* Indicator 24-25
- TAPE* Indicator 24-25
- Tape Positioning 19
- Things to Avoid 60
- Tilt Adjustment 23

Index

Time and Date Display24-25,26,27
Time and Date Recording27
Time Remaining Display21,24
TINT Control9,23
Tips, Cassette18
Tips, Recording39
Tips, Traveling18
TIME/DATE Button8,25,26-27
TITLE SEL + and - Buttons8,36-38
TITLE SEL Button8,36-38
TITLER Button8,36-38
Titler36-38
TRACKING (Also Power Zoom)
 Buttons42,43
Traveling Tips18
Tripod, Using56
Trouble Checks62-64

— U —

Unpacking the Camcorder3
User Information69
Using a Tripod56
Using Adapter/Charger10
Using the Rechargeable Battery . .11-14

— V —

VCR/OFF/CAMERA Switch . .5,7,12,19,
 26-27,33,35,36-38,41,42,45,47
VIDEO/AUDIO
 Jacks8,32-33,34-35,44-45,46
Video Cassettes16-17
Video Light48-49
Viewfinder6,8,22-23,42,61
Viewfinder Playback42
Viewfinder, Cleaning61

— W —

Warranty, Limited66-67

— Z —

Zoom Buttons9,28
Zoom Level Control24,28
Zooming28

Need Assistance? We want to help!

U.S. Consumers:

Camcorder Exchange Warranty800-283-6503

Customer Service800-336-1900

Accessories800-338-0376

Canadian Consumers:

English800-522-0338

French800-522-0445

If your camcorder needs service, please contact your dealer or the nearest Servicenter from the yellow pages. Please do not send any products to the Indianapolis address listed in this manual or on the carton. This will only add delays in service for your product.

THOMSON CONSUMER ELECTRONICS

**10330 N Meridian Street
Indianapolis, IN 46290**

©1995 Thomson Consumer Electronics, Inc.

Trademark(s)[®] Registered

Marca(s) Registrada(s)

Printed in Japan

Part Number 95-CC423-1

QR12653

Free Manuals Download Website

<http://myh66.com>

<http://usermanuals.us>

<http://www.somanuals.com>

<http://www.4manuals.cc>

<http://www.manual-lib.com>

<http://www.404manual.com>

<http://www.luxmanual.com>

<http://aubethermostatmanual.com>

Golf course search by state

<http://golfingnear.com>

Email search by domain

<http://emailbydomain.com>

Auto manuals search

<http://auto.somanuals.com>

TV manuals search

<http://tv.somanuals.com>