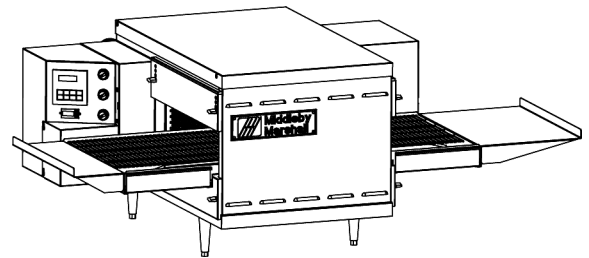
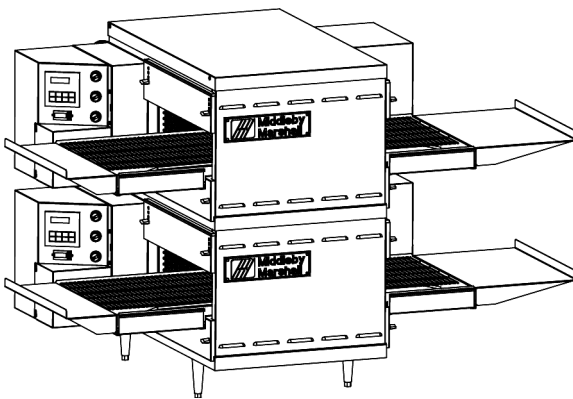


# *owner's operating & installation manual*

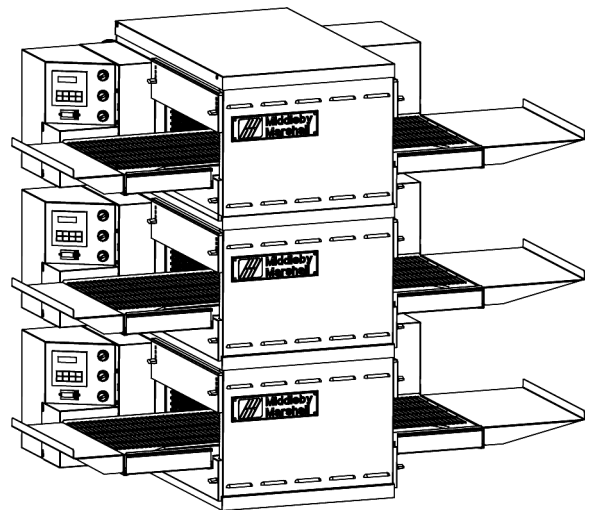
**PS528-Series OVENS  
Model PS528G**



PS528 (Single)



PS528 (Double)



PS528 (Triple)



**NOTICE:**

This Owner's Operating and Installation Manual should be given to the user. The operator of the oven should be familiar with the functions and operation of the oven.

This manual must be kept in a prominent, easily reachable location near the oven.

Ovens are shipped from the factory configured for use with natural gas. If permitted by local, national and international codes, at the time of installation the oven may be converted to propane gas operation. This conversion requires the use of a Gas Conversion Kit that is supplied with the oven. For CE-approved ovens, the conversion is described in the *Installation* section of this Manual. For domestic and standard export ovens, instructions are included in the Gas Conversion Kit.

It is suggested to obtain a service contract with a Middleby Marshall Authorized Service Agent.

**WARNING**

**POST, IN A PROMINENT LOCATION, THE EMERGENCY TELEPHONE NUMBER OF YOUR LOCAL GAS SUPPLIER AND INSTRUCTIONS TO BE FOLLOWED IN THE EVENT YOU SMELL GAS.**

Instructions to be followed in the event the user smells gas shall be obtained by consulting the local gas supplier. If the smell of gas is detected, immediately call the emergency phone number of your local Gas Company. They will have personnel and provisions available to correct the problem.

**WARNING**

**FOR YOUR SAFETY, DO NOT STORE OR USE GASOLINE OR OTHER FLAMMABLE VAPORS AND LIQUIDS IN THE VICINITY OF THIS OR ANY OTHER APPLIANCE.**

**WARNING**

**Improper installation, adjustment, alteration, service, or maintenance can cause property damage, injury, or death. Read the installation, operation, and maintenance instructions thoroughly before installing or servicing this equipment.**

**NOTICE**

The warranty is *NOT VALID* **unless** the oven is installed, started, and demonstrated under the supervision of a factory-authorized installer.

**NOTICE**

Contact your authorized Service Agency to perform maintenance and repairs. A Service Agency Directory is supplied with your oven.

**NOTICE**

Using any parts other than genuine Middleby Marshall factory-manufactured parts relieves the manufacturer of all warranty and liability.

**NOTICE**

Middleby Marshall (Manufacturer) reserves the right to change specifications at any time.

**KEEP THIS MANUAL IN A VISIBLE LOCATION NEAR THE OVEN FOR FUTURE REFERENCE.**

**MIDDLEBY MARSHALL**  
**NO QUIBBLE LIMITED WARRANTY**  
**(U.S.A. ONLY)**

MIDDLEBY MARSHALL, HEREINAFTER REFERRED TO AS "THE SELLER", WARRANTS EQUIPMENT MANUFACTURED BY IT TO BE FREE FROM DEFECTS IN MATERIAL AND WORKMANSHIP FOR WHICH IT IS RESPONSIBLE. THE SELLER'S OBLIGATION UNDER THIS WARRANTY SHALL BE LIMITED TO REPLACING OR REPAIRING, AT SELLER'S OPTION, WITHOUT CHARGE, ANY PART FOUND TO BE DEFECTIVE AND ANY LABOR AND MATERIAL EXPENSE INCURRED BY SELLER IN REPAIRING OR REPLACING SUCH PART. SUCH WARRANTY SHALL BE LIMITED TO THE ORIGINAL PURCHASER ONLY AND SHALL BE EFFECTIVE FOR A PERIOD OF ONE YEAR FROM DATE OF ORIGINAL INSTALLATION, OR 18 MONTHS FROM DATE OF PURCHASE, WHICHEVER IS EARLIER, PROVIDED THAT TERMS OF PAYMENT HAVE BEEN FULLY MET.

This warranty is valid only if the equipment is installed, started, and demonstrated under the supervision of a factory-authorized installer.

Normal maintenance functions, including lubrication, cleaning, or customer abuse, are not covered by this **no quibble warranty**.

Seller shall be responsible only for repairs or replacements of defective parts performed by Seller's authorized service personnel. Authorized service agencies are located in principal cities throughout the contiguous United States, Alaska, and Hawaii. This warranty is valid in the 50 United States and is void elsewhere unless the product is purchased through Middleby International with warranty included.

***The foregoing warranty is exclusive and in lieu of all other warranties, expressed or implied. There are no implied warranties of merchantability or of fitness for a particular purpose.***

The foregoing shall be Seller's sole and exclusive obligation and Buyer's sole and exclusive remedy for any action, including breach of contract or negligence. In no event shall Seller be liable for a sum in excess of the purchase price of the item. Seller shall not be liable for any prospective or lost profits of Buyer.

***This warranty is effective on Middleby Marshall equipment sold on, or after, February 15, 1995.***

**MIDDLEBY MARSHALL INC.**  
**OVEN LIMITED WARRANTY**  
**(Non U.S.A.)**

The Seller warrants equipment manufactured by it to be free from defects in material and workmanship for which it is responsible. The Seller's obligation under this warranty shall be limited to replacing or repairing, at Seller's option, without charge, F.O.B. Seller's factory, any part found to be defective and any labor and material expense incurred by Seller in repairing or replacing such part. Such warranty is limited to a period of one year from date of original installation or 15 months from date of shipment from Seller's factory, whichever is earlier, provided that terms of payment have been fully met. All labor shall be performed during regular working hours. Overtime premium will be charged to the Buyer.

**This warranty is not valid unless equipment is installed, started, and demonstrated under the supervision of a factory-authorized installer.**

Normal maintenance functions, including lubrication, adjustment of airflow, thermostats, door mechanisms, microswitches, burners and pilot burners, and replacement of light bulbs, fuses and indicating lights, are not covered by warranty.

Any repairs or replacements of defective parts shall be performed by Seller's authorized service personnel. Seller shall not be responsible for any costs incurred if the work is performed by other than Seller's authorized service personnel.

When returning any part under warranty, the part must be intact and complete, without evidence of misuse or abuse, freight prepaid.

Seller shall not be liable for consequential damages of any kind which occur during the course of installation of equipment, or which result from the use or misuse by Buyer, its employees or others of the equipment supplied hereunder, and Buyer's sole and exclusive remedy against Seller for any breach of the foregoing warranty or otherwise shall be for the repair or replacement of the equipment or parts thereof affected by such breach.

The foregoing warranty shall be valid and binding upon Seller if and only if Buyer loads, operates and maintains the equipment supplied hereunder in accordance with the instruction manual provided to Buyer. Seller does not guarantee the process of manufacture by Buyer or the quality of product to be produced by the equipment supplied hereunder and Seller shall not be liable for any prospective or lost profits of Buyer.

THE FOREGOING WARRANTY IS EXCLUSIVE AND IN LIEU OF ALL OTHER EXPRESS AND IMPLIED WARRANTIES WHATSOEVER. SPECIFICALLY THERE ARE NO IMPLIED WARRANTIES OF MERCHANTABILITY OR OF FITNESS FOR A PARTICULAR PURPOSE.

The foregoing shall be Seller's sole and exclusive obligation and Buyer's sole and exclusive remedy for any action, whether in breach of contract or negligence. In no event shall seller be liable for a sum in excess of the purchase price of the item.

**TABLE OF CONTENTS**

	Page
<b>SECTION 1</b>	
I. MODEL IDENTIFICATION .....	1
SERIES PS528 GAS SPECIFICATIONS .....	2
II. COMPONENT FUNCTION .....	4
A. Conveyor Motor and Conveyor Belt .....	4
B. Blower Fan .....	4
C. Gas Burner .....	4
D. Cooling Fan .....	4
E. Air Fingers and Blank Plates - See Figure 1-9 .....	4
<b>SECTION 2</b>	
I. UNLOADING .....	8
<b>PARTS LIST FOR SERIES PS528 GAS OVEN</b>	
INSTALLATION KIT .....	8
<b>UTILITY ROUGH-IN DIMENSIONS AND POSITIONING</b>	
FOR PS528-SERIES OVENS .....	13
CIRCUIT BREAKER.....	13
ELECTRICAL SPECIFICATIONS .....	13
ELECTRICAL RATING.....	13
SUPPLY WIRE .....	13
SUGGESTED.....	13
II. VENTILATION GUIDELINES.....	13
III. ELECTRICAL CONNECTION INFORMATION FOR	
PS528-SERIES OVENS.....	14
IV. ELECTRIC SUPPLY FOR GAS HEATED OVENS .....	14
V. GAS SUPPLY .....	15
<b>SECTION 3 INSTALLATION</b>	
I. CONTROL FUNCTIONS .....	19
II. COMPONENT INFORMATION AND LOCATION .....	20
A. Door Safety Switch .....	20
B. Blower Switch .....	20
C. Heat Switch .....	20
D. Temperature Controller.....	20
E. Conveyor .....	21
MEASURING CONVEYOR SPEED. ....	21

**TABLE OF CONTENTS  
(Continued)**

	Page
III. STEP-BY-STEP OPERATION .....	22
A. Startup Procedures .....	22
Daily Startup.....	22
Power Failure.....	22
B. Shutdown Procedure .....	22
IV. NORMAL OPERATION - STEP-BY-STEP.....	24
A. Daily Startup Procedure.....	24
B. Daily Shutdown Procedure .....	24
V. QUICK REFERENCE: TROUBLESHOOTING .....	26
<b>SECTION 4 MAINTENANCE</b>	
I. MAINTENANCE - DAILY.....	28
A. Exterior .....	28
B. Cooling Fan.....	28
C. Conveyor Belt .....	28
D. Crumb Pans .....	28
II. MAINTENANCE - MONTHLY .....	29
A. Removing Conveyor From Oven For Cleaning ....	29
B. Air Fingers Disassembly For Cleaning.....	31
C. Reassembly of Air Fingers .....	32
D. Reinstall End Plugs .....	35
E. Conveyor Reassembly Into Oven.....	36
F. Checking Conveyor Belt Tension.....	36
G. Conveyor Belt Link Removal.....	37
H. Attaching Drive Chain .....	38
III. MAINTENANCE - EVERY 3 MONTHS .....	39
A. Electrical Terminals.....	39
B. Ventilation .....	39
IV. MAINTENANCE - EVERY 6 MONTHS.....	39
<b>PS528-SERIES GAS OVEN KEY SPARE</b>	
PARTS .....	40
KEY SPARE PARTS KIT .....	40
<b>SECTION 5 TROUBLESHOOTING</b>	
Troubleshooting Charts.....	41
<b>SECTION 6 ELECTRICAL SCHEMATICS</b>	
Wiring Diagram, G208-240V 50/60 GO, PS528 .....	43

**NOTE**

Wiring Diagrams are in Section 6 of this Manual.  
The diagram for each oven is also on the lower  
inner surface of its Control Console.

# SECTION 1 DESCRIPTION

## I. MODEL IDENTIFICATION

The Middleby Marshall PS528-Series may be used either as a single oven or stacked for use as double or triple ovens.

A single PS528-Series Oven (Figure 1-1) is mounted on a base pad with legs. A double oven (Figure 1-2) consists of two, *stacked*, single ovens. A triple oven (Figure 1-3) consists of three stacked single ovens. The lower oven is mounted on a base pad with stacking pins.

On a double or triple oven, the ovens operate independently. All ovens use identical controls and components. One oven can be cleaned or serviced, while the others are operating.

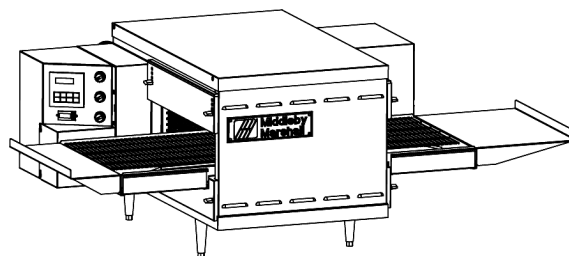


Figure 1-1. Single PS528 Oven

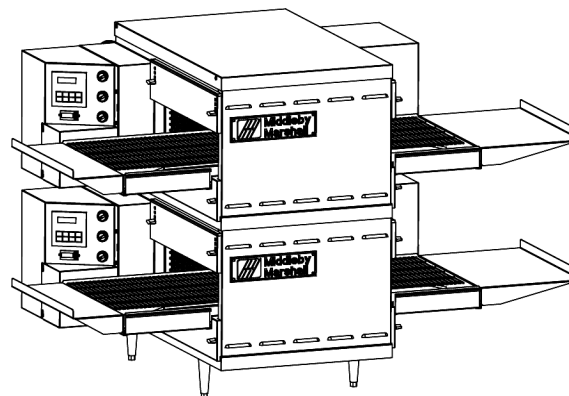


Figure 1-2. Double PS528 Oven

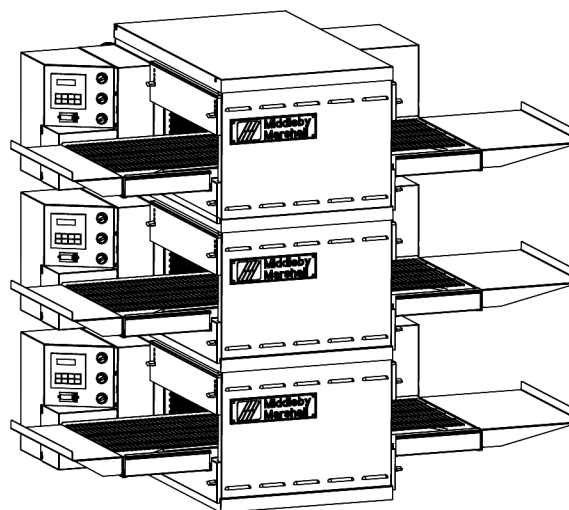


Figure 1-3. Triple PS528 Oven

SECTION 1  
DESCRIPTION

**PS528 SERIES OVEN SPECIFICATIONS**

Conveyor Belt Width	18.00" (457mm)
Heating Zone Length	28.00" (711mm)
Baking Area Square Feet	3.5 sq. ft. (0.33 sq. m.)
Overall Dimension Standard Single Oven w/Legs	50.00" (1270mm) L x 40.75" (1035mm) W x 21.72" (786mm) H x
Overall Dimension Double Oven	50.00" (1270mm) L x 40.75" (1035mm) W x 37.27" (947mm) H x
Overall Dimension Triple Oven	50.00" (1270mm) L x 40.75" (1035mm) W x 52.82" (1342mm) H x
Weight of Single Oven	250 lb (93.3kg)
Shipping Weight	325 lb (121.3kg)
Shipping Cube	22.1 ft <sup>3</sup> (0.62 m <sup>3</sup> )
BTU's - Natural or Propane Gas	50,000 BTU/hr (53 MJ/hr)
Gas Input - Natural or Propane Gas	1/2" NPT (1/2" BS)
Maximum Operating Temperature	600°F (316°C)
Warm-up Time	20 min.
Belt Speed Limits	1-10 minutes

**SERIES PS528 ELECTRICAL SPECIFICATIONS**

Main Blower & Elements Voltage	Control Circuit Voltage	Phase	Frequency	Amperage Draw	Poles	Wires
208-240V	208-240V	1 Ph	50/60 Hz	1.5 Amp	2 Pole	3 Wire (2 hot, 1 grd)

**GAS ORIFICE AND PRESSURE SPECIFICATIONS (PER OVEN CAVITY) - DOMESTIC AND STANDARD EXPORT OVENS**

Gas Type	Main Orifice I.D.	Supply (Inlet) Pressure	Orifice (Manifold) Pressure
Natural	#42 drill (.094")(2.38mm)	6-8" W.C. (14.9-19.9mbar) * (1.49-3 KPA)	3.5" W.C. (8.72mbar) (0.872 KPA)
Propane	#48 drill (.076")(1.93mm)	6-8" W.C. (14.9-19.9mbar) * (1.49-3 KPA)	3.5" W.C. (8.72mbar) (0.872 KPA)

\* The gas supply pressures and orifice sizes shown are for ovens installed in North America. The required gas supply pressures and orifice sizes of ovens installed in other locations are dependent on the local gas type and on all applicable local codes.

**GAS ORIFICE AND PRESSURE SPECIFICATIONS (PER OVEN CAVITY) - CE OVENS**

Supply (Inlet) Pressure

Gas Type	Main Orifice dia.	Supply (Inlet) Pressure					Orifice (Manifold) Pressure	Rated Heat Input
		IT,PT,ES,SE, UK,CH,IT,AT, DK,FI I <sub>2H</sub>	DE I <sub>2E</sub>	BE,FR I <sub>2E+</sub>	SE,CH,AT,DK, FI,DE,NL I <sub>3B/P</sub>	BE,IE,IT,PT, ES,UK I <sub>3+</sub>		
G20	2.3749 mm	20 mbar	20 mbar	20 mbar	--	--	11.21 mbar	22.36 kW-hr.
G25	2.3749 mm	--	--	--	--	--	16.19 mbar	22.36 kW-hr.
G30	1.3970 mm	--	--	--	29 or 50 mbar	28-30, 37 or 50 mbar	26.2 mbar	22.59 kW-hr.

**NOTE**

Wiring Diagrams are contained in Section 6 of this Manual and are also located inside the oven at the bottom of the Control Panel.

Additional electrical information is provided on the oven's serial plate.

**This Manual Must Be Kept For Future Reference.**

II. COMPONENT FUNCTION (Figure 1-4)

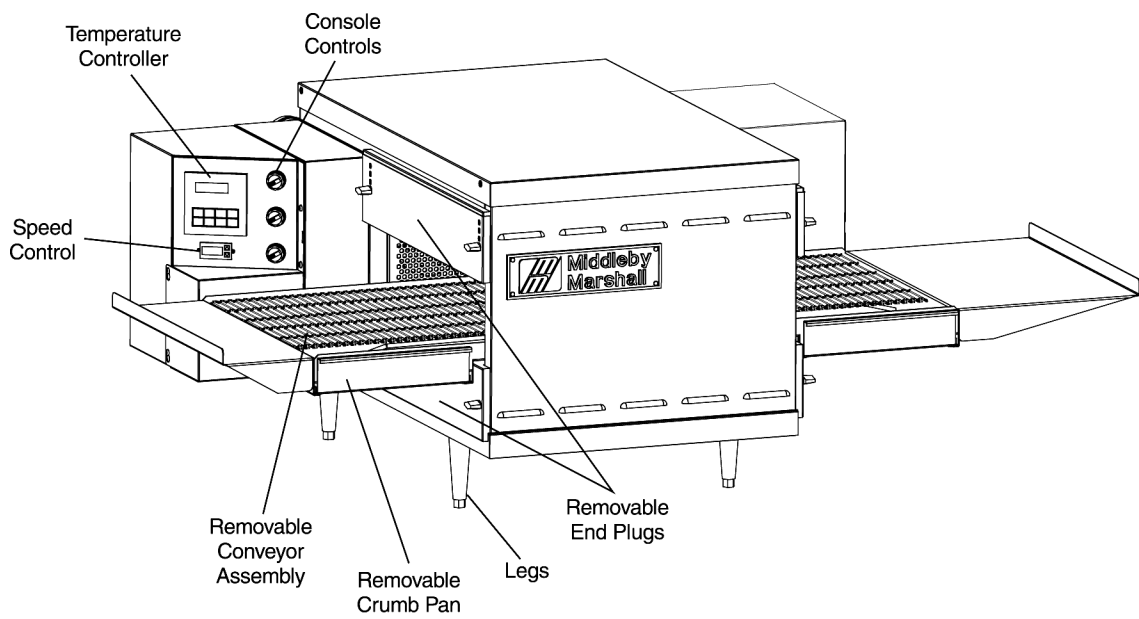


Figure 1-4. PS528-Series Oven Components Locations



## SECTION 1 DESCRIPTION

### II. COMPONENT FUNCTION

#### A. Conveyor Motor and Conveyor Belt

The conveyor belt is driven by a variable-speed electric motor (Figure 1-5) operating through a gear reducer. The motor speed is controlled by a digital control. The stainless-steel wire belt can travel in either direction at variable rates ranging from 3 minutes to 30 minutes; this is the time that a product can take to pass through the oven.

#### B. Blower Fan

The blower fans are located at the rear of the oven. These blowers force heated air through the air fingers. The BLOWER switch must be set to "ON" or "I" for oven warmup and baking.

#### C. Gas Burner

The gas burner is located inside the rear panel and is controlled by the temperature controller.

#### D. Cooling Fan — See Figure 1-5 and Figure 1-6

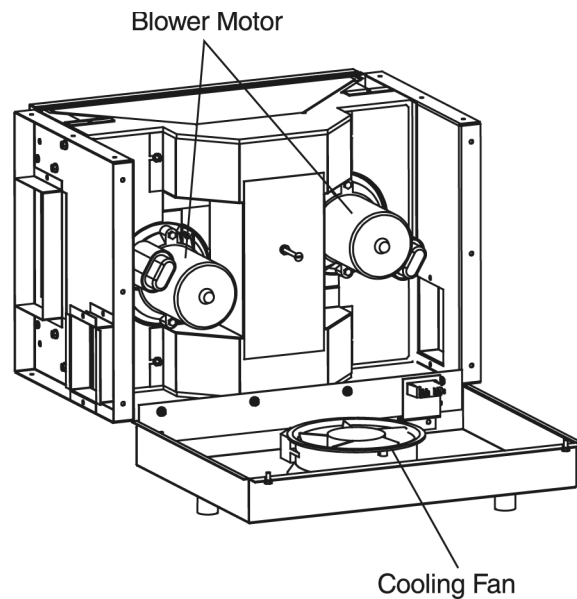
The cooling fan is located in the back of the oven. The cooling fan draws air through its grille, blowing it through the blower motor compartment and the control compartments into the oven top and exhausted out the front louvers.

#### E. Air Fingers and Blank Plates - See Figure 1-7

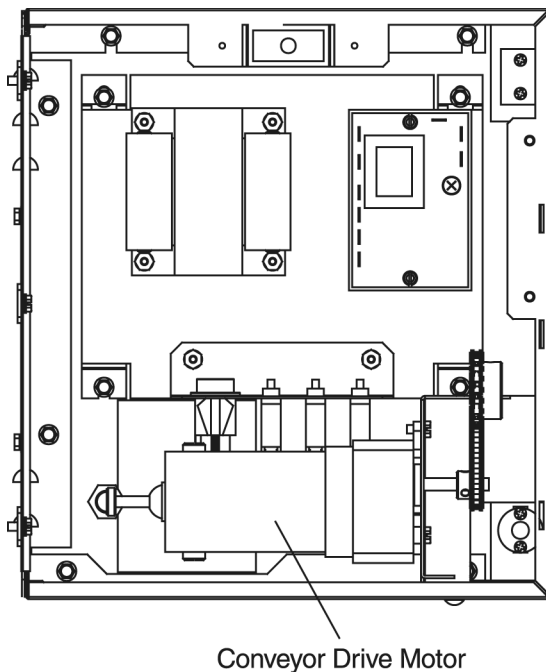
##### E1. Air Fingers

An Air Finger Assembly is made up of three parts:

1. **Outer Plate** - The Outer Plate is the removable covering with tapered holes, which direct the air stream onto the product being baked.
2. **Inner Plate** -The perforated Inner Plate is vital in forming the unique air jets. It must be assembled into the manifold with its holes aligned with the holes of the outer plate.
3. **Manifold** - The Manifold is the assembly which slides on tracks into the oven plenum.



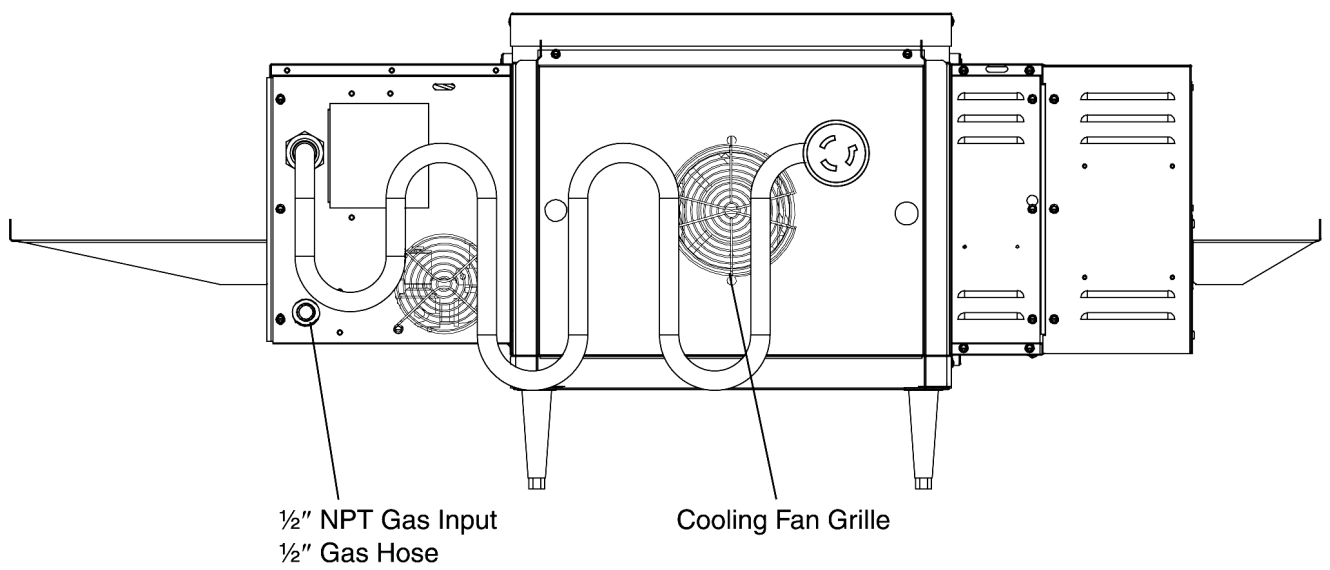
Blower Assembly



Right Control Box

**Figure 1-5. Machinery Compartment Components**



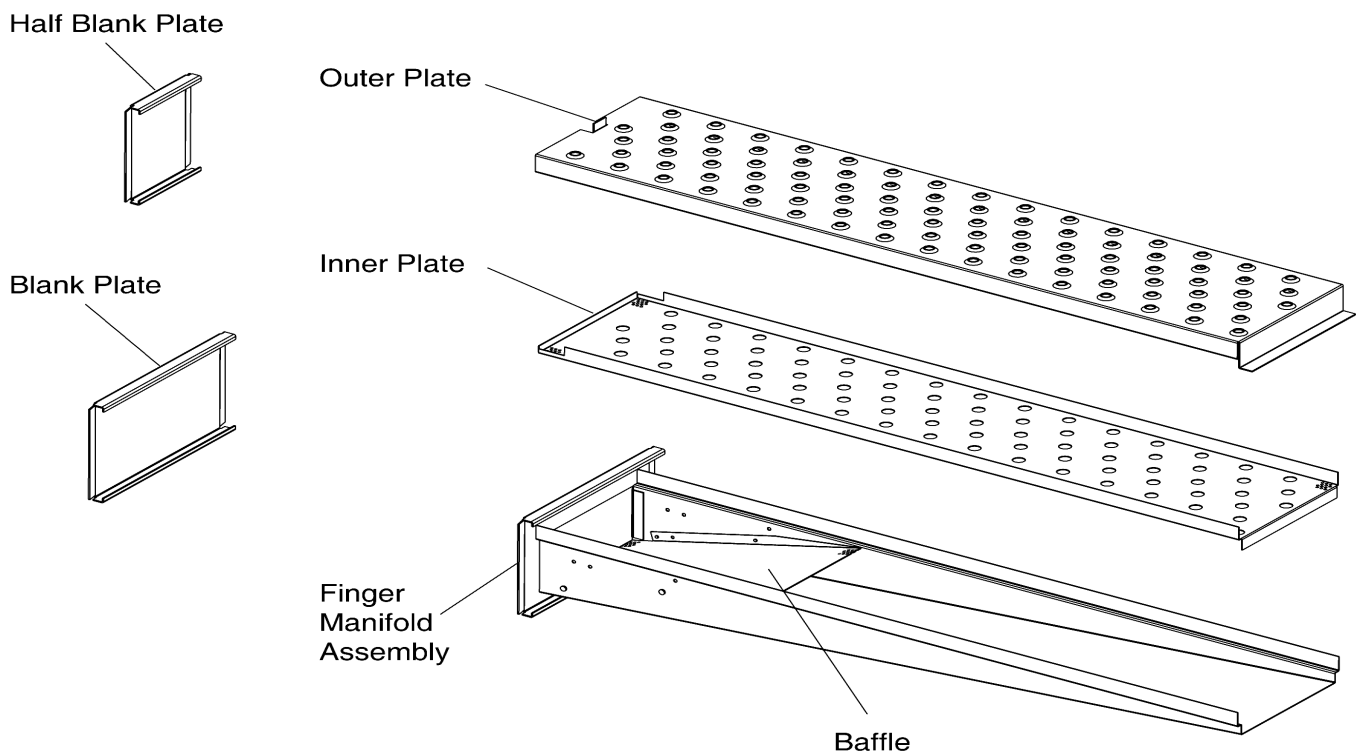


**Figure 1-6. Cooling Fan**

SECTION 1  
DESCRIPTION

**F2. Blank Plates**

1. **Blank Plates-** The Blank Plates are available to install on the plenum where an air finger is not required.



**Figure 1-7. Blank Plates (two sizes) and an Air Finger.**

## SECTION 2 INSTALLATION

**WARNING - For gas ovens, after any conversions, readjustments, or service work on the oven:**

- Perform a gas leak test.
- Test for correct air supply.
- Test for proper combustion and gas supply.
- Check that the ventilation system is in operation.

### WARNING

Keep the appliance area free and clear of combustibles.

### WARNING

The oven must be installed on an even (level) non-flammable flooring and any adjacent walls must be non-flammable. Recommended minimum clearances are specified in the *Description* section of this Manual.

### WARNING

Do not obstruct the flow of combustion and ventilation air to and from your oven. There must be no obstructions around or underneath the oven. Constructional changes to the area where the oven is installed shall not affect the air supply to the oven.

### CAUTION

For additional installation information, contact your local Authorized Service Agent.

### NOTE

There must be adequate clearance between the oven and combustible construction. Clearance must also be provided for servicing and for proper operation.

### NOTE

An electrical wiring diagram for the oven is located inside the machinery compartment.

### NOTE

*All aspects of the oven installation, including placement, utility connections, and ventilation requirements, must conform with any applicable local, national, or international codes. These codes supersede the requirements and guidelines provided in this manual.*

### NOTE

*In the USA, the oven installation must conform with local codes. In the absence of local codes, gas oven installations must conform with the National Fuel Gas Code, ANSI Z223.1. Installed ovens must be electrically grounded in accordance with local codes, or in the absence of local codes, with the National Electrical Code (NEC), or ANSI/NFPA70.*

### NOTE

*In Canada, the oven installation must conform with local codes. In the absence of local codes, gas oven installations must conform with the Natural Gas Installation Code, CAN/CGA-B149.1, or the Propane Gas Installation Code, CAN/CGA-B149.2, as applicable. Installed ovens must be electrically grounded in accordance with local codes, or in the absence of local codes, with the Canadian Electrical Code CSA C22.2.*

### NOTE

*In Australia, the oven installation must conform with any requirements of the appropriate statutory authority. Gas oven installations must conform with AGA Codes AG311 and AG601.*

### NOTE

*In CE countries, all aspects of the gas supply connection must comply with current IEC/CEE requirements and with all applicable local, national, and international codes. In addition, four casters are provided to allow the oven to be more easily moved to the installation location. These casters are intended to simplify pre-installation movement only, and are NOT suitable for use as part of a CE oven installation. During the installation procedure, the casters MUST be removed, so that the oven can be supported by the supplied 152mm adjustable legs.*

## SECTION 2 INSTALLATION

**NOTE:** The oven, when installed, must be electrically grounded in accordance with local codes, or in the absence of local codes, with the National Electrical Code (NEC), or ANSI/NFPA70.

### NOTE

There must be adequate clearance between the oven and any adjacent combustible construction. Clearance must also be provided for servicing and for operation.

### CAUTION

It is recommended that the oven be placed under a ventilation hood for adequate air supply and ventilation.

### CAUTION

Do not obstruct the flow of ventilation air to and from your oven. Do not obstruct the fan holes in the rear of the unit.

## I. UNLOADING

Your Middleby Marshall PS528-Series Oven is shipped partially assembled. It will arrive in a carton on a crate.

The crate and carton must be examined before signing the Bill of Lading. Report any visible damage to the transport company, and check for the proper number of crates. If apparent damage is found, make arrangements to file a claim against the carrier. Surface Interstate Commerce Regulations (U.S.A.) require that the claim must be initiated by the consignee within 10 days from the date that the shipment is received.

### PARTS LIST FOR SERIES PS528 GAS OVEN INSTALLATION KIT Single Stack Oven P/N 63946

ITEM NO.	QTY	PART NO.	DESCRIPTION
1	4	3101908	LEG 4" AD FT
2	1	62208	INSULATION BOTTOM TRAY
3	1	62206	BOTTOM TRAY WELDMENT
4	1	61650	TOP COVER
5	4	51387	SCREW MSSLT THREAD 8-32 × 1/2, 18-8
7	1	22450-0228	GAS HOSE RESTRAINT CABLE
8	1	22361-0001	GAS HOSE
9	1	49975	CORD & PLUG NEMA L6-20P
10	1	23115-0009	MANUAL GAS VALVE, 3/4" × 1/2, COUPLER
11	1	31823	REDUCER, 3/4" – 1/2"
12	4	62207	INSULATION

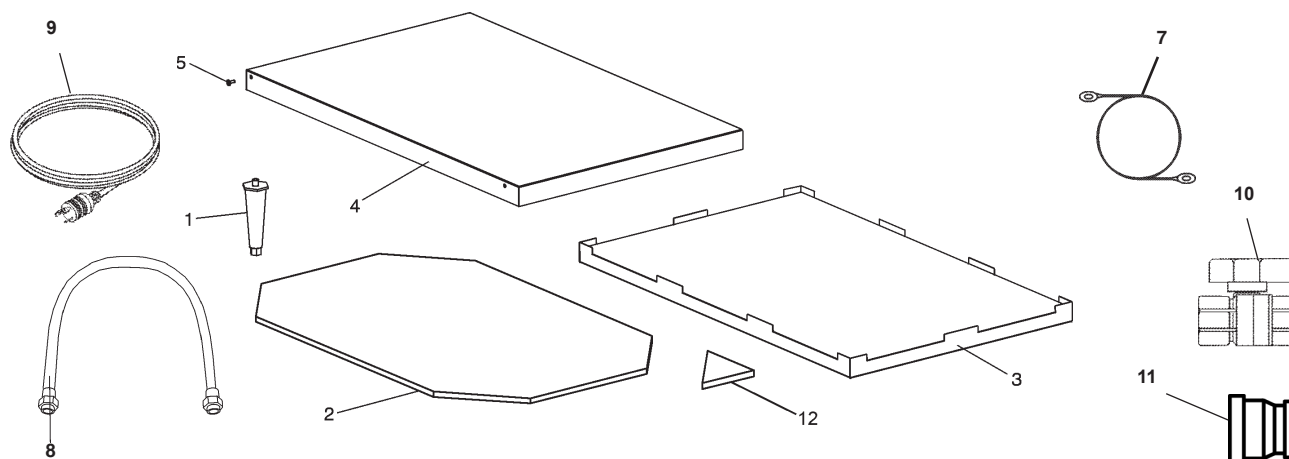
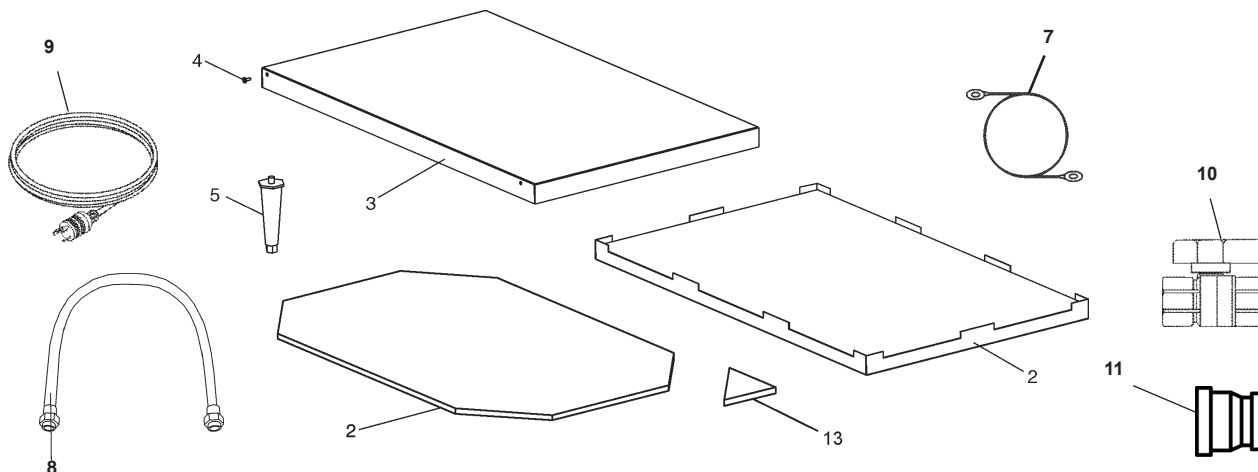


Figure 2-1. PS528-Series Gas Oven Installation Parts

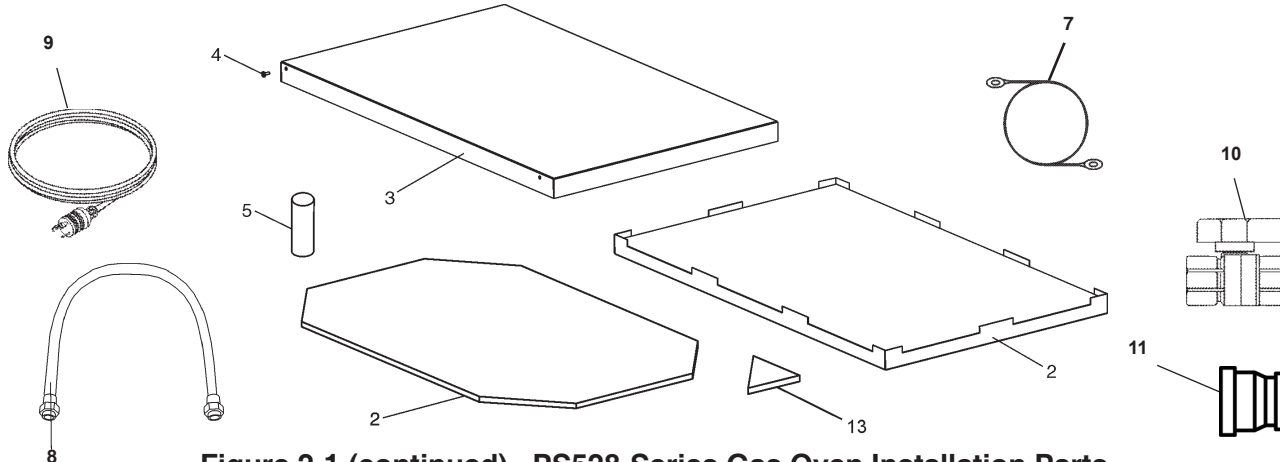
**PARTS LIST FOR SERIES PS528 Gas OVEN  
INSTALLATION KIT Double Stack Oven P/N 63947**

ITEM NO.	QTY	PART NO.	DESCRIPTION
1	2	62208	INSULATION BOTTOM TRAY
2	1	62206	BOTTOM TRAY WELDMENT
3	1	61650	TOP COVER
4	4	51387	SCREW MSSLT THREAD 8-32 × 1/2, 18-8
5	4	3101908	LEG 4" AD FT
7	1	22450-0228	GAS HOSE RESTRAINT CABLE
8	2	22361-0001	GAS HOSE
9	1	49975	CORD & PLUG NEMA L6-20P
10	1	23115-0009	MANUAL GAS VALVE, 3/4" × 1/2, COUPLER
11	1	31823	REDUCER, 3/4" – 1/2"
12	1	59227	HEAT GUARD
13	4	62207	INSULATION



**PARTS LIST FOR SERIES PS528 Gas OVEN  
INSTALLATION KIT Triple Stack Oven P/N 63948**

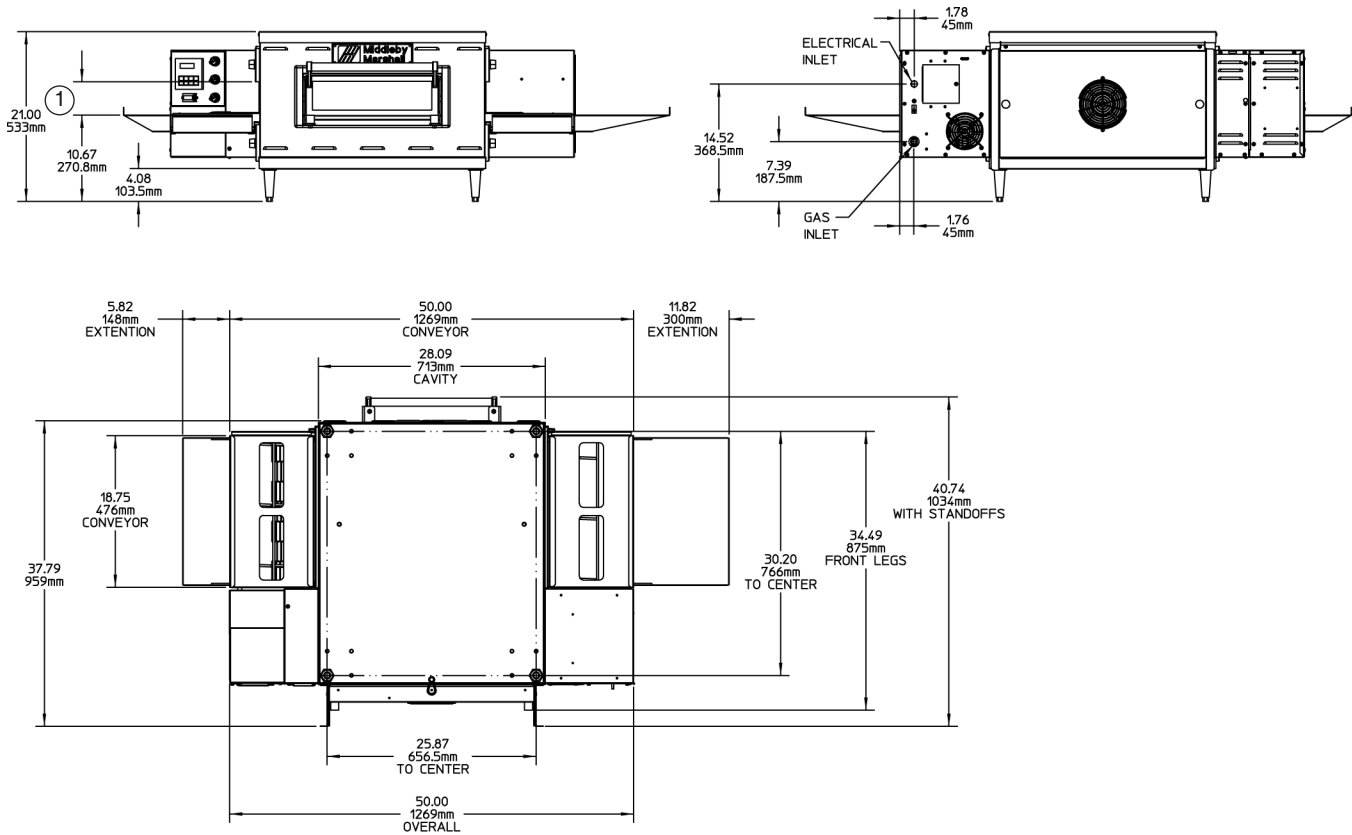
ITEM NO.	QTY	PART NO.	DESCRIPTION
1	2	62208	INSULATION BOTTOM TRAY
2	1	62206	BOTTOM TRAY WELDMENT
3	1	61650	TOP COVER
4	4	51387	SCREW MSSLT THREAD 8-32 × 1/2, 18-8
5	4	M3828	PIN, ALIGNMENT
7	1	22450-0228	GAS HOSE RESTRAINT CABLE
8	3	22361-0001	GAS HOSE
9	1	49975	CORD & PLUG NEMA L6-20P
10	1	23115-0009	MANUAL GAS VALVE, 3/4" × 1/2, COUPLER
11	1	31823	REDUCER, 3/4" – 1/2"
12	2	59227	HEAT GUARD
13	4	62207	INSULATION



**Figure 2-1 (continued). PS528-Series Gas Oven Installation Parts**

SECTION 2  
INSTALLATION

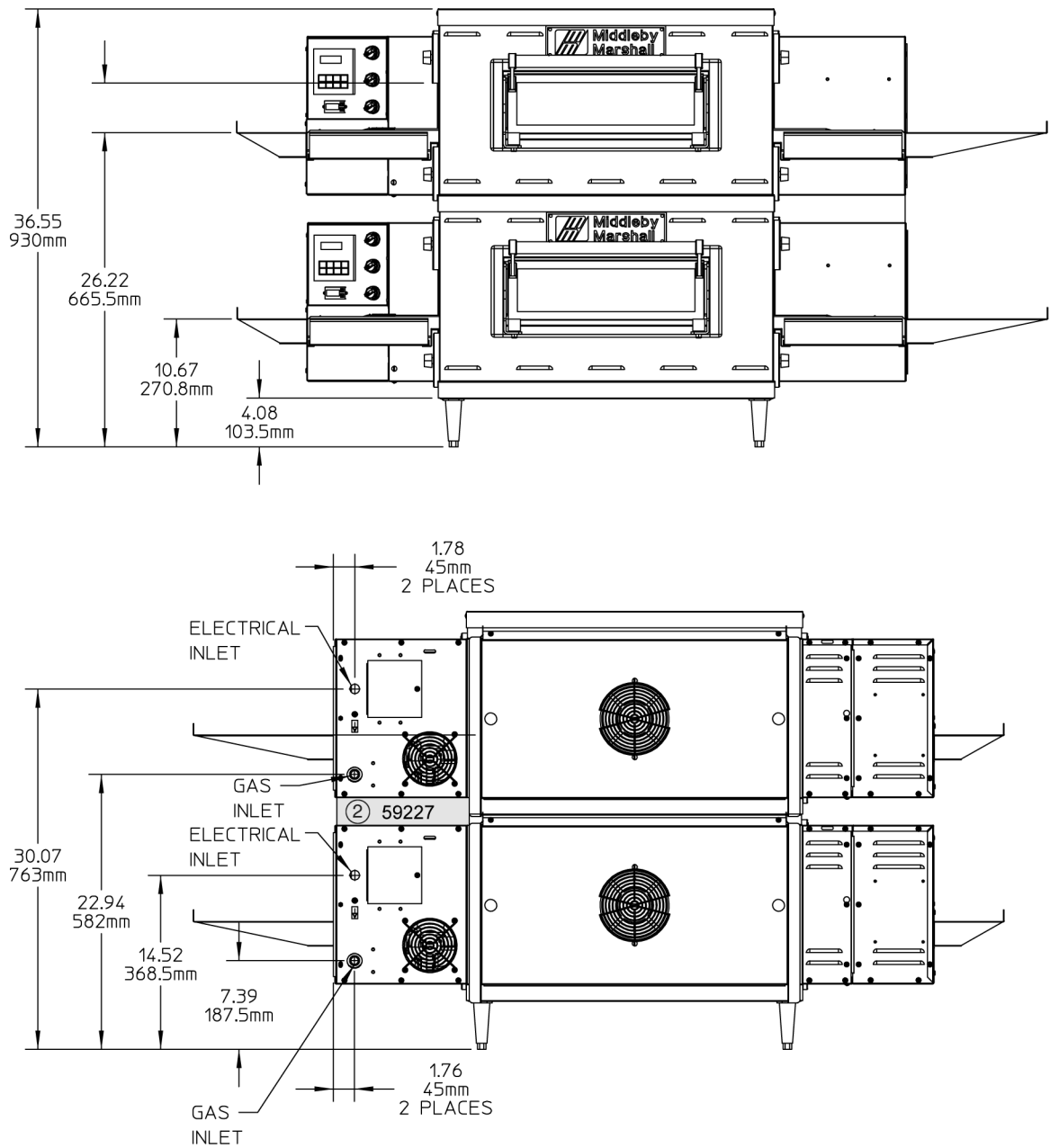
Figure 2-5. MODEL PS528 SINGLE OVEN DIMENSIONS



1

The Opening Height is Adjustable from 2-1/4 inch minimum to 3-3/4 inch maximum in 1/2 inch increments.

Figure 2-6. MODEL PS528 DOUBLE OVEN DIMENSIONS



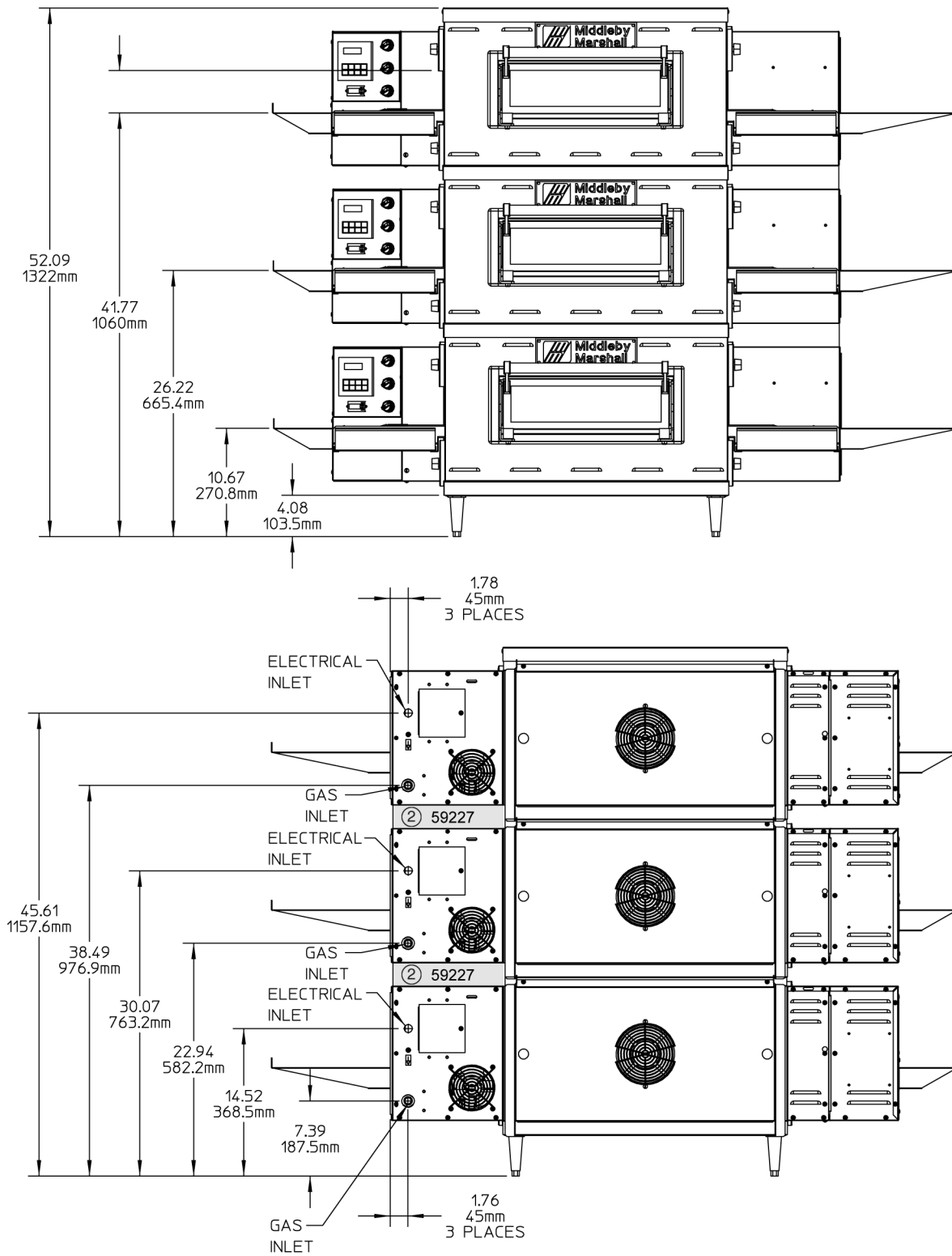
① The Opening Height is Adjustable from 2-1/4 inch minimum to 3-3/4 inch maximum in 1/2 inch increments.

② P/N 59927 is shown in its correct installed position.



SECTION 2  
INSTALLATION

Figure 2-7. MODEL PS528 TRIPLE OVEN DIMENSIONS



① The Opening Height is Adjustable from 2-1/4 inch minimum to 3-3/4 inch maximum in 1/2 inch increments.

② P/N 59927 is shown in its correct installed position.

UTILITY ROUGH-IN DIMENSIONS AND POSITIONING  
FOR PS528-SERIES OVENS

**WARNING**  
DO NOT USE CONDUIT OR GAS LINE  
FOR GROUND CONNECTION.

**CAUTION**  
IT IS RECOMMENDED THAT THE OVEN  
BE PLACED UNDER A VENTILATION  
HOOD FOR ADEQUATE AIR SUPPLY  
AND VENTILATION.

ELECTRIC SUPPLY TO BE  
PROVIDED BY CUSTOMER

**CIRCUIT BREAKER**

Separate circuit breaker with lockout/tagout electrical shutoff for each oven. Wire each oven separately.

15A Amp circuit breaker for 208-240V.

**ELECTRICAL SPECIFICATIONS**

**DOMESTIC:** 208V main blower motors, 1 Ph, 1.5 Amp draw, 50/60 Hz, 208-240V control circuit, 2 pole, 3 wire system per oven (2 hot, 1 grd).

**Do NOT** use conduit for ground.

or

**DOMESTIC or EXPORT:** 240V main blower motors, 1 Ph, 1.5 Amp draw, 50/60 Hz, 208-240V control circuit, 2 pole, 3 wire system per oven (2 hot, 1 grd).

230V main blower motors, 1 Ph, 1.5 Amp draw, 50/60 Hz, 208-240V control circuit, 2 pole, 3 wire system per oven (2 hot, 1 grd).

**Do NOT** use conduit for ground.

A 6 foot cord with a NEMA L6-20 plug is supplied on Domestic units.

**POWER RATING**

50,000 BTU/hr (14.7 kW/hr.)

**SUPPLY WIRE**

Supply wire size must be in accordance with the National Electrical Code (current edition) and must be in compliance with local codes.

**SUGGESTED**

If space permits, service should be located near the control console end of the oven(s) to allow convenient access to safety switches.

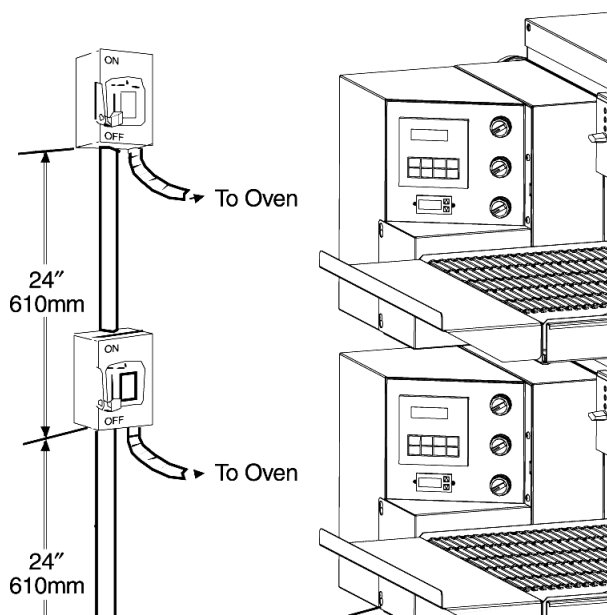


Figure 2-9. Typical PS528-Series Oven(s) Installation

**CAUTION**  
UNIT MUST HAVE AIR VENT PLATES  
INSTALLED OR WARRANTY WILL BE VOID.

**II. VENTILATION GUIDELINES**

A mechanically driven ventilation system is required for the PS528 Series Middleby Marshall conveyORIZED gas ovens.

Local codes and conditions vary greatly from one area to another and must be complied with. Following are the suggested requirements for good ventilation. Please remember these are recommendations or guidelines, you may have a special condition or problem that will require the services of a ventilation engineer or specialist. Proper ventilation is the oven owner's responsibility. Improper ventilation can inhibit oven performance.

**Please Note:** There are now two "stand off" 'C' Channels and "Heat Guards" for "Double and Triple Ovens" that must be installed in the field.

**Please Note:** There is now one heat guard on double units and two heat guards on triple units. See Figure 2-7.

These 'C' Channel brackets are installed in the vertical plane using existing screws (Item 6) to support these 'C' Channels using the upper and lower Key Hole openings in the 'C' Channels. The 'C' Channels are identical and once installed will allow ample amounts of air through the cooling fan mounted on the rear side of the oven by keeping the oven away from the rear wall.

SECTION 2  
INSTALLATION

III. ELECTRICAL CONNECTION  
INFORMATION FOR PS528-SERIES  
OVENS.

**WARNING**

Authorized supplier personnel normally accomplish the connections for the ventilation system, electric and gas supplies, as arranged by the customer. Following these connections, the factory-authorized installer can perform the initial startup of the oven.

Check the oven data plate (Figure 2-10) before making any electric supply connections. Electric supply connections must agree with data on the oven data plate.

**NOTE:** The electric supply installation must satisfy the requirements of the appropriate statutory authority, such as the National Electrical Code (NEC), ANSI/NFPA70, (U.S.A.); the Canadian Electrical Code, CSA C22.2; the Australian Code AG601; or other applicable regulations.

A fused disconnect switch or a main circuit breaker (customer furnished) MUST be installed in the electric supply line for each oven; it is recommended that this switch/circuit breaker have lockout/tagout capability. The electric supply connection must meet all national and local electrical code requirements. Copper is the recommended material for the electrical supply conductors.

IV. ELECTRIC SUPPLY FOR GAS HEATED  
OVENS

Power requirements for gas heated ovens are 208 - 240VAC, 1-phase, 3-wire (2 'hot', 1 ground). Electrical connection is made through a cord and plug. Using flexible cable(s) for the electrical power supply conductors requires a 2" (51mm) strain-relief fitting (not furnished) to enable safe access to the terminal block from which oven power is distributed.

The supply conductors must be of the size and material (copper) recommended to provide the current required; (refer to the data plate for the ampere specifications). The electric current rating for each conductor supplying a PS528-Series Oven is 1.5A.

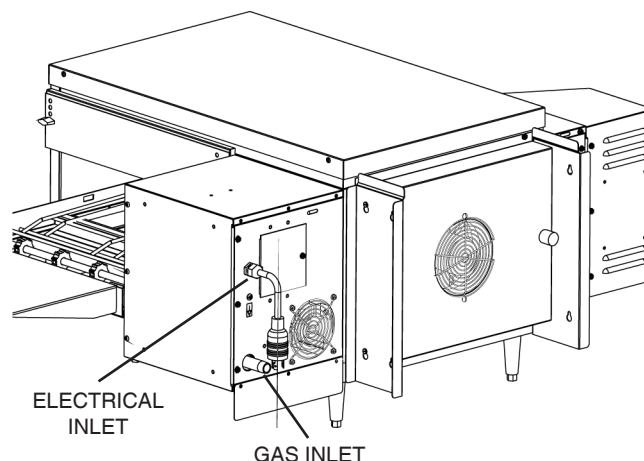


Figure 2-11. Junction Connection Box

MIDDLEBY®  
MARSHALL  
1400 TOASTMASTER DRIVE ELGIN ILLINOIS 60120 USA

MOD. TYP  SR.-NR:  ANNO   
ID.-NR:

	TTPTES.SE.GB CHEAT.DK.FUR	NL	LI DE	BEPR	SECHAT.DKND FIDEAL.OUR	NEUTR PTES.OGB
CAT	Q2H	Q2L	Q2E	Q2+	Q5/P	Q5+
P	Q20 20	Q25 25	Q30 30	Q35 35/25	Q30 28-30/50	Q36 28-36/70

Qn = kW   
U = V,  Hz ~  
A = A   
TYPE A

0359

THIS APPLIANCE IS FOR  
PROFESSIONAL USE  
AND SHALL BE USED  
BY QUALIFIED PEOPLE.

PHN 45636 REV 6

INTERNATIONAL CE PLATE

1400 TOASTMASTER DRIVE  
ELGIN, ILLINOIS 60120 U.S.A.

MODEL NO.  SERIAL NO.   
Numero de modelo Numero de serie

ID NO.  TYPE OF GAS   
Type de gaz

INPUT STUBS PER HOUR MAXIMUM   
Chauffage maximum par heure, en BTU

MAX. PRESS.  IN. H<sub>2</sub>O/PSI  WIRE WITH GROUND  
Collage avec solde à la masse

VAC  AMPS  PHASE  Hz

SUITABLE FOR INSTALLATION ON COMBUSTIBLE FLOORS ADJACENT TO COMBUSTIBLE AND NONCOMBUSTIBLE WALLS WITH THE FOLLOWING MINIMUM CLEARANCES: ( ) INCHES TO LEFT SIDE, ( ) INCHES RIGHT SIDE & ( ) INCHES TO BACK WALLS. FOR INSTALLATION UNDER VENTILATION HOOD ONLY. INTENDED FOR OTHER THAN HOUSEHOLD USE.

ADAPTE POUR ETRE INSTALLE SUR DES PLANCHERS INFLAMMABLES, ADJACENTS A DES MURS COMBUSTIBLES ET NON COMBUSTIBLES, ET RESPECTANT LES ESPACEMENTS MINIMUM SUIVANTS PARVOIR GAUCHE ( ) POUCES, PARVOIR DROITE ( ) POUCES, PARVOIR ARRIERE ( ) POUCES. POUR UNE INSTALLATION SOUS UNE HOTTE DE VENTILATION SEULEMENT. DESTINE A UN USAGE AUTRE QUE DOMESTIQUE.

5849 REV D

DOMESTIC PLATE

Figure 2-10. Typical Electric Oven Data Plate

## V. GAS SUPPLY

### CAUTION

**DURING PRESSURE TESTING NOTE THE FOLLOWING:**

1. The oven and its individual shutoff valve must be disconnected from the gas supply piping system during any pressure testing of that system at test pressure in excess of 1/2 psi (3.45 kPa).

2. The oven must be isolated from the gas supply piping system by closing its individual manual shutoff valve during any pressure testing of the gas supply piping system at test pressure equal to or less than 1/2 psi (3.45 kPa).

3. If incoming pressure is over 14" W.C. (35mbar), a separate regulator **MUST** be installed in the line **BEFORE** the individual shutoff valve for the oven.

**WARNING:** To prevent damage to the control valve regulator during initial turn-on of gas, it is very important to open the manual shutoff valve very slowly.

After the initial gas turn-on, the manual shutoff valve must remain open except during pressure testing as outlined in the above steps or when necessary during service maintenance.

### A. Gas Utility Rough-In Recommendations

The following gas system specifications are **STRONGLY RECOMMENDED**. Deviating from these recommendations may affect the baking performance of the oven.

Gas Meter - 650 cfh (307ℓ/min) meter

#### Gas Line

- DEDICATED LINE from the gas meter to the oven
- 1-1/2" (38.1mm) pipe for natural gas
- 1-1/2" (38.1mm) pipe for propane
- Maximum length: 200' (61m). Each 90° elbow equals 7' (2.13m) of pipe.

### B. Gas Conversion

Where permitted by local and national codes, it is possible to convert ovens from natural to propane gas, or from propane to natural gas. Use the appropriate Middleby Gas Conversion Kit for the specific oven model.

**CAUTION:** The terms of the oven's warranty require all start-ups, conversions and service work to be performed by a Middleby Authorized Service Agent.

### C. PS528 Propane Conversion

Two items have to be changed, to change the oven to LP:

1. Replace main orifices.
2. Adjust main gas regulator per instructions below.

Disconnect the manifold union closest to the main burner, and remove the manifold assembly (four screws). Slide out the manifold assembly (leaving the ignition and sense wires connected). Replace the main orifices.

Replace the main orifices on the manifold assemblies with the LP units, and replace the manifold assembly. Reconnect the union.

### D. Adjusting the Maximum Pressure Setting

1. Disconnect pressure feedback connection (if applicable).
2. Connect a suitable pressure gauge to pipe line or to outlet

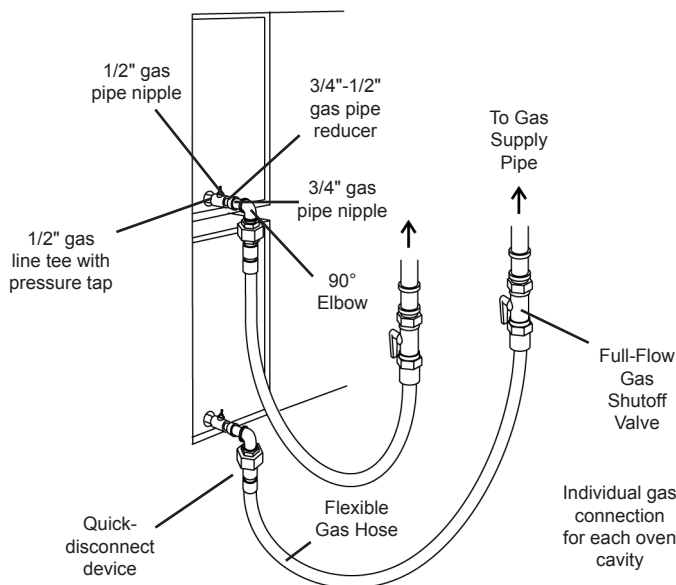
pressure tap of gas control concerned, to measure burner pressure (measuring point must be as near to burner as possible).

3. Make sure that the appliance is in operation and the Moduplus® coil is energized with maximum current.
4. If maximum rate pressure needs adjustment, use an 8 mm wrench to turn adjustment screw for maximum pressure setting (clockwise to increase or counter-clockwise to decrease pressure), until the desired maximum outlet pressure is obtained.
5. Disconnect electrical connection of the Moduplus®.
6. Check minimum pressure setting and readjust if necessary. (See Adjusting Minimum Pressure Setting for proper adjusting procedure.)
7. Reconnect pressure feedback connection (if applicable).
8. If minimum and maximum pressures are set, wire the Moduplus® in circuit.
9. Close pressure tap screw.

### E. Adjusting the Minimum Pressure Setting

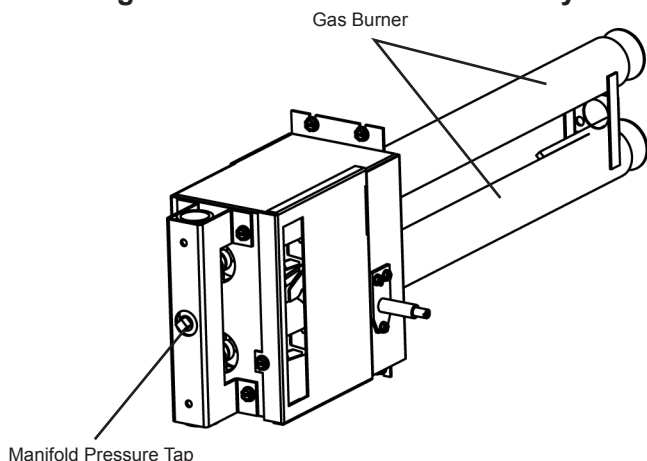
1. Disconnect pressure feedback connection (if applicable).
2. Connect a suitable pressure gauge to pipe line or to outlet pressure tap of gas control concerned, to measure burner pressure (measuring point must be as near to burner as possible).
3. Disconnect electrical connection of the Moduplus®.
4. Energize operator, set control in operation and wait until an outlet pressure is recorded on pressure gauge.
5. If minimum rate pressure needs adjustment, use an 8 mm wrench to turn adjustment screw for minimum pressure setting (clockwise to increase or counter-clockwise to decrease pressure), until the desired minimum outlet pressure is obtained.
6. Check if main burner lights easily and reliable at minimum pressure.
7. Reconnect pressure feedback connection (if applicable).
8. Close pressure tap screw.

Figure 2-15 - Flexible Gas Hose Installation

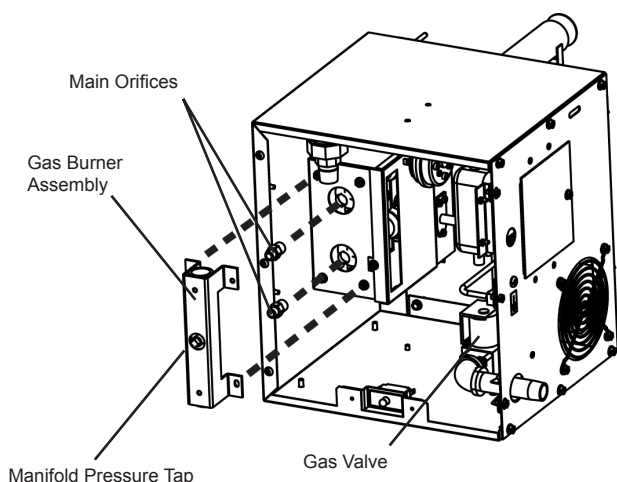


## SECTION 2 INSTALLATION

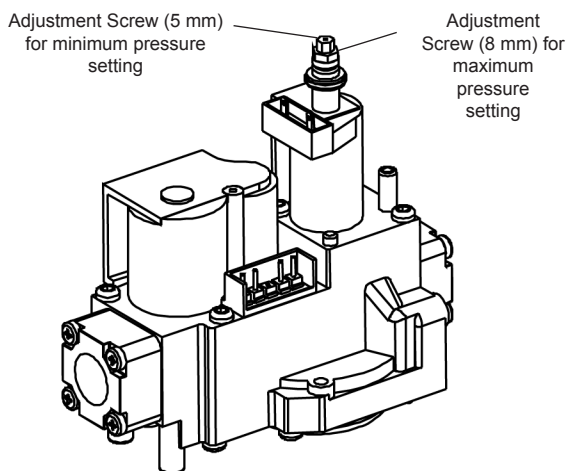
**Figure 2-16. Gas Burner Assembly**



**Figure 2-17. Burner Assembly**



**Figure 2-18. Gas Valve**



### F. Checkout

After any adjustment, set appliance in operation and observe through a component cycle to ensure that burner system components function correctly.

### G. Maintenance

It is recommended to check yearly the minimum and the maximum setting and readjust them if necessary.

### H. Connection

#### WARNING



Some procedures in this section may require conversions, readjustments, or service on the oven's gas system. Before performing these procedures, check that the main gas supply valve and the circuit breaker/fused disconnect are in the OFF ("O") position. After completing these procedures, perform a gas leak test before operating the oven.

#### CAUTION

The terms of the oven's warranty require all start-ups, conversions and service work to be performed by a Middleby Marshall Authorized Service Agent. The installation, start-up and changes required when changing from one gas type to another can be performed ONLY by a certified professional.

**NOTE:** Certain safety code requirements exist for the installation of gas ovens; refer to the beginning of Section 2 for a list of the installation standards. In addition:

- *In the USA*, the installation must conform with local codes, or in the absence of local codes, with the National Fuel Gas Code, ANSI Z223.1.
- *In Canada*, the installation must conform with local codes, or in the absence of local codes, with the Natural Gas Installation Code, CAN/CGA-B 149.1, or the Propane Installation Code, CAN/CGA-B 149.2, as applicable.
- *In Australia*, the installation must conform with AGA Codes AG311 and AG601, and with any requirements of the appropriate statutory authority.
- *In CE countries*, the gas supply connection should be according to EN-203 (gas appliance directive) and to applicable ISO 228-1 or ISO 7-1 recommendations. All aspects of the gas supply connection must comply with current IEC/CEE requirements and with all applicable local, national, and international codes.
- *For all ovens equipped with casters*, the gas line connection shall be made with:
  - A connector that complies with the Standard for Connectors for Movable Gas Appliances, ANSI Z21.69 (in USA), or Connectors for Movable Gas Appliances, CAN/CGA-6.16 (in Canada).

Check the oven's gas supply requirements to determine the type of gas to be used with the oven. If the gas type required does NOT match the local supply:

- For North American installations, a conversion kit is supplied with the oven to allow operation using propane gas. Refer to Part B, Gas Conversion, in this section.
- For CE ovens, directions for converting the oven for use with other gases are described in Part D.1, Preparation for Use with Various Gases, in this section.



If the installation will use the supplied gas hose, be sure that the 1/2" to 3/4" gas line fitting is attached. Refer to the instructions in the gas hose package. One gas line connection method is shown in Figure 2-15; however, compliance with the applicable standards and regulations is mandatory.

Inlet and regulated gas pressures can be measured using a "U" tube manometer at the tap locations shown in Figures 2-15 and 2-16.

1. *Checking the Gas Supply (Inlet) Pressure*

- a. With the main gas supply valve closed and the circuit breaker/fused disconnect in the OFF ("O") position, open the inlet pressure tap shown in Figure 2-16 and attach a manometer to the tap.
- b. Depress the safety switches to allow the oven to operate.
- c. Open the main gas supply valve. Switch the circuit breaker/fused disconnect to the ON ("I") position.
- d. Start the oven according to the directions in the Operation section of this Manual. Adjust the temperature controller to the maximum setting (316°C).
- e. Measure the supply (inlet) pressure.
- f. Switch the oven off. Close the main gas supply valve, and switch the circuit breaker/fused disconnect to the OFF ("O") position. Remove the manometer, and close the inlet tap.
- g. Compare the measured supply (inlet) pressure to the nominal pressures shown in Table 1-5 (in the Description section of this Manual).

If the supply pressure is lower or higher than the nominal pressure, the reason should be investigated and the gas supplier contacted.

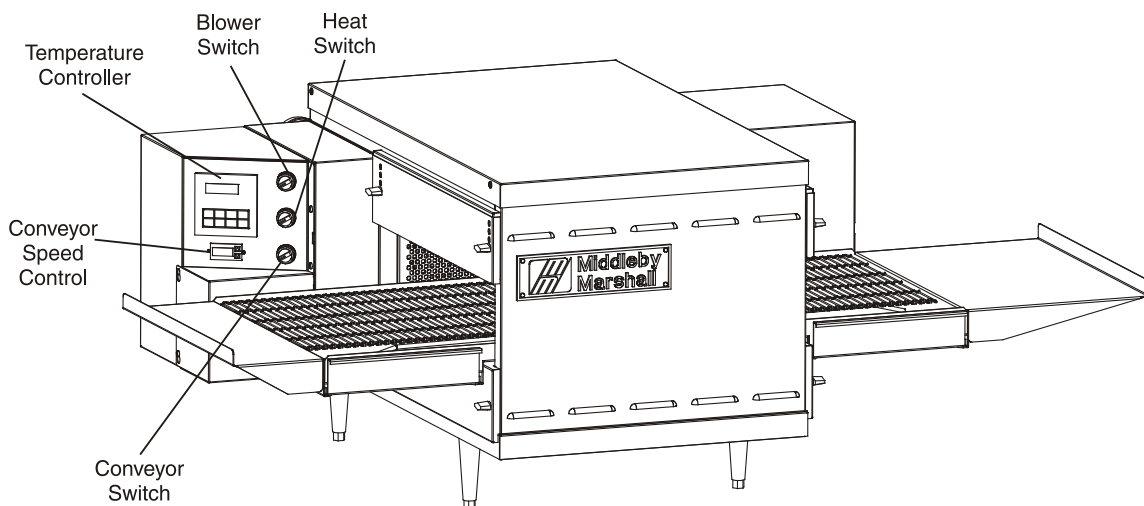
For natural gas ovens, if the measured supply pressure is lower than 0.247psi, or higher than 0.363psi, contact the gas supplier. DO NOT OPERATE THE OVEN or adjust the oven controls.

## NOTES



## SECTION 3 OPERATION

### I. CONTROL FUNCTIONS



**Figure 3-1. PS528-Series Oven Control Functions**

#### **WARNING**

A possibility of injury from rotating parts and electric shock exists in this oven. Never disassemble or clean the oven with the BLOWER switch or any other oven control turned "ON" or "I". Turn "OFF" or "O" and lockout or tagout all electric power to the oven before attempting to clean or service this oven.

## SECTION 3 OPERATION

### II. COMPONENT INFORMATION AND LOCATION (Figures 3-1 and 3-2)

#### A. Door Safety Switch

The Door Safety Switch is located at the lower right side of control panel opening. Opening the control panel door permits this switch to open, disconnecting power to all electrical controls.

#### CAUTION

Do NOT touch the wires going to this safety switch. Current is always present.

#### B. Blower Switch

The blower switch has two positions. The switch must be "ON" or "I" for the main blowers to come on and permit the oven to run. The fan circulates the air throughout the oven and must stay on during baking and during the cool down cycle above 200°F (93°C) to prevent blower bearing damage. To protect the blower motor and bearings a thermostatic override is built into the oven.

If the temperature inside the oven is over 180°F (82°C) the main blower will continue to run after the blower switch is turned to the "OFF" or "O" position.

#### C. Heat Switch

The "Heat Switch" allows the burner to activate. Activation is determined by the settings on the Digital Temperature Controller.

#### D. Temperature Controller

The temperature controller is a solid-state, PID type to maintain the operator-set temperature. The temperature controller continuously monitors the oven temperature and turns on the modulating solid state relay controller. The heat is on for the time required to maintain a constant oven temperature.

The temperature controller contains a low-limit switch which allows the oven to cool down to 200°F (93°C) before shutting off the blower. A high-limit indication (ALM 1) will appear on the display if the oven reaches 650°F (343°C).

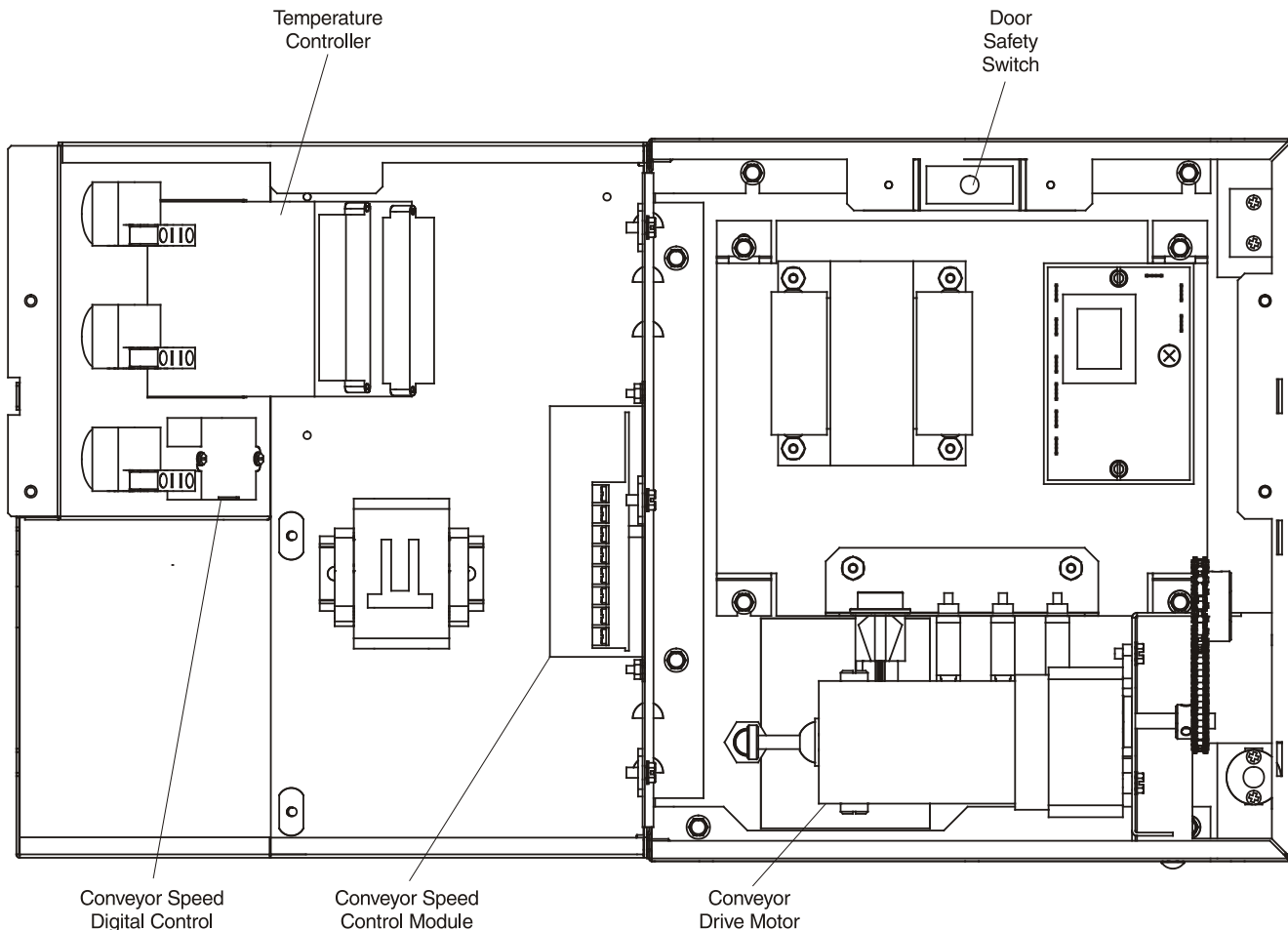


Figure 3-2. Interior View of Control Console

**E. Conveyor**

The on-off switch for the conveyor motor is on the control panel. Also on the control panel is the digital conveyor speed control. The digital control can be adjusted from 1-10 min. bake time (conveyor speed). Refer to Figure 3-3.

Conveyor speed is measured by the amount of time it takes for an item to go through the bake chamber of the oven.

**MEASURING CONVEYOR SPEED.**

See Figures 3-4 and 3-5.

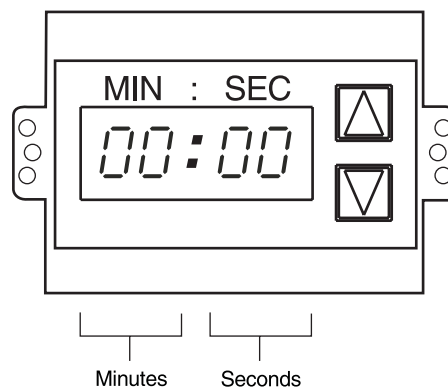
To check conveyor speed, place a product item at the entrance end of baking chamber as shown. Time how long it takes for the leading edge of the item to go from the entrance end of the baking chamber to the exit end. This should be the conveyor speed shown on the conveyor speed digital control.

**NOTE:** In Figures 3-4 and 3-5, the oven shown is with the conveyor running right to left.

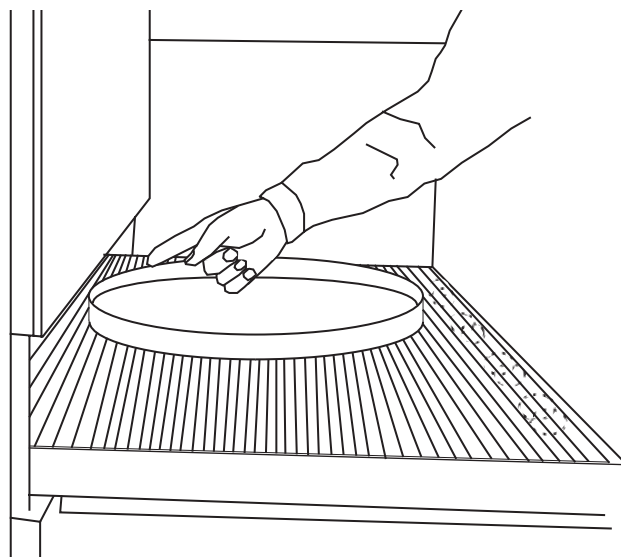
**WARNING**

Possibility of injury from rotating parts and electrical shock exist in this oven.

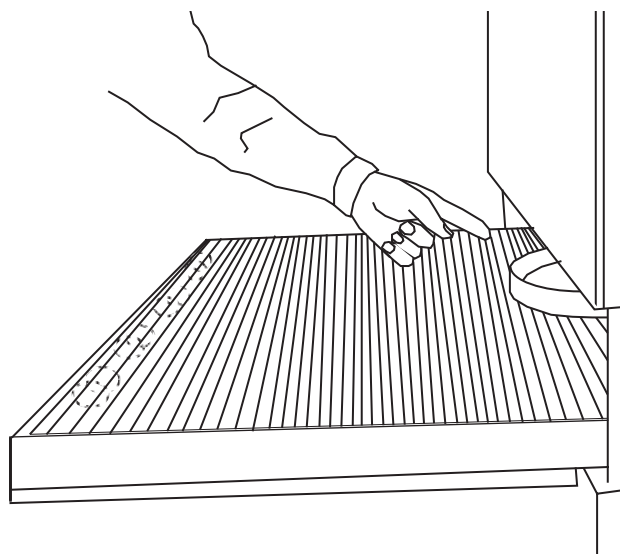
Never disassemble or clean the oven with the blower switch or any other part of the oven turned "ON" or "I". Turn "OFF" or "O" and lock-out or tagout all electrical power to the oven before attempting to clean or service this oven.



**Figure 3-3. Conveyor Speed Digital Control**



**Figure 3-4. Product at entrance end of baking chamber – BEGINNING OF TIMING**



**Figure 3-5. Product at exit end of baking chamber – END OF TIMING**

## SECTION 3 OPERATION

**WARNING**  
**OVEN MUST BE KEPT CLEAR OF  
COMBUSTIBLES AT ALL TIMES.**

### III. STEP-BY-STEP OPERATION

#### A. Startup Procedures

##### Daily Startup

1. Turn the BLOWER switch (Figure 3-6) to the "ON" or "I" position. This starts the main blower fan and the cooling fans. The blower circulates air through the air fingers and must stay on during the cooking or baking process.
2. Check to see if the cooling fans (see Figure 1-8) are operating when the blower switch (see Figure 3-6) is turned "ON" or "I". The cooling fans cool the control components and blower motor. The cooling fans, located at the rear of the oven blows air into and through the cabinet. Air is exhausted through the front of the cabinet and also out the front of the oven. Refer to Daily Maintenance Section for fan intake checking procedure.

##### IMPORTANT NOTE

The cooling fan operates when the BLOWER switch is turned "ON" or "I". It must operate to keep the control console below 140°F (60°C).

3. Turn the CONVEYOR switch (Figure 3-6) to the "ON" or "I" position. This starts the conveyor belt moving through the oven. Set the conveyor speed for the desired baking time. Refer to the following Procedures E, F and G.

4. Set the temperature controller to the desired baking temperature.

**NOTE:** For complete temperature controller operation instructions refer to Step C.

5. Turn the HEAT switch (Figure 3-6) to the "ON" or "I" position. Wait for the "Heat ON" light to turn on.
6. Oven will reach a baking temperature of 500°F (232°C) in approximately 20 minutes. Allow the oven to cycle for 30 minutes after it has reached desired bake temperature. The oven is now ready for baking.

##### Power Failure

In case of power failure, turn off all switches and remove product. After power has been reestablished follow normal startup procedure.

#### B. Shutdown Procedure

1. Turn the BLOWER and HEAT switches to "OFF" or "O".
- NOTE:** The blowers will remain on until the oven temperature cools down to 200°F (93°C) at which time they will stop automatically.
2. Make certain that there are no products left on the conveyor inside the oven. Turn the CONVEYOR switch to "OFF" or "O".

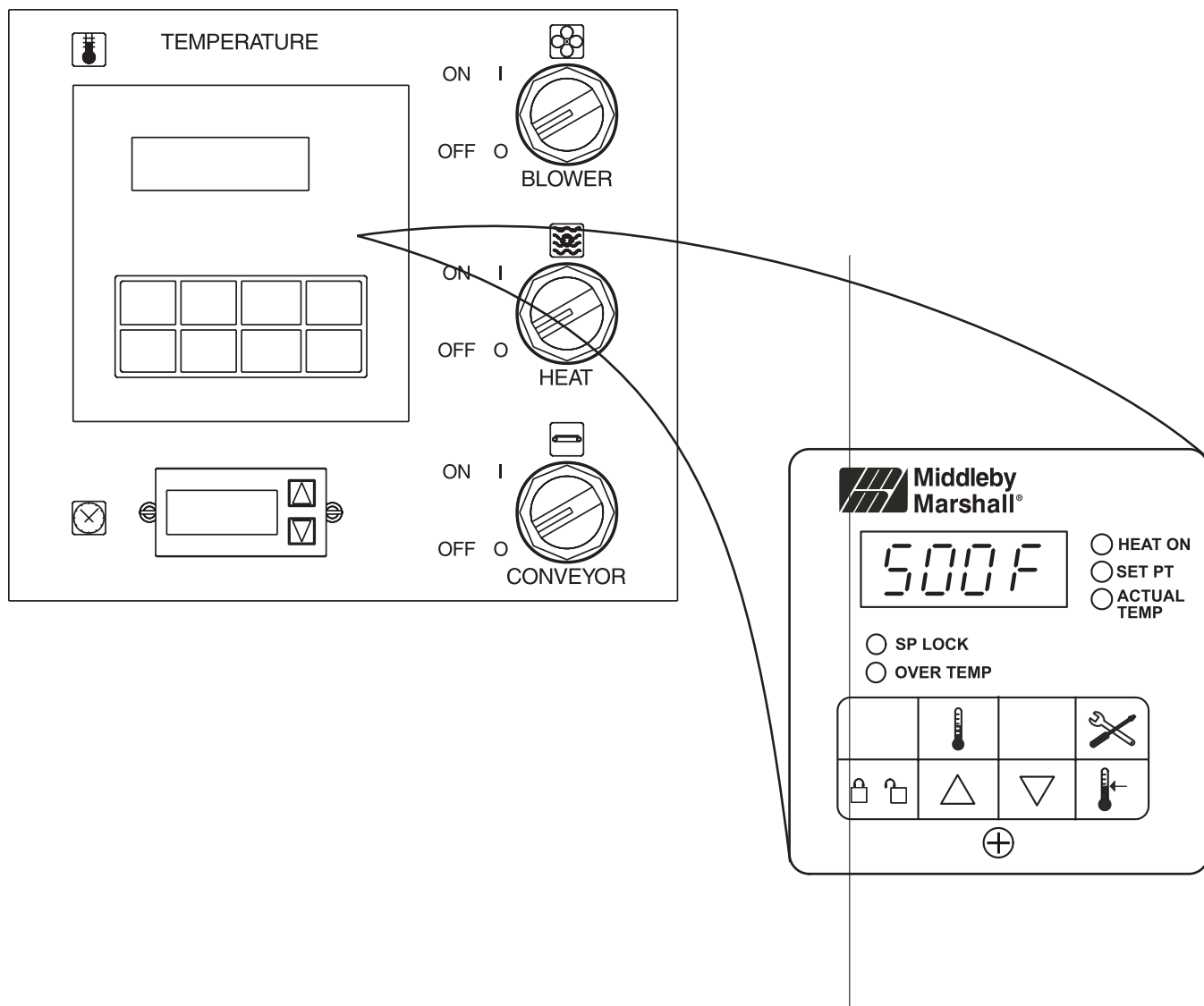


Figure 3-6. Control Panel

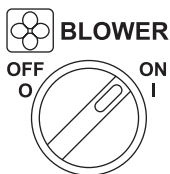
# SECTION 3 OPERATION

## IV. NORMAL OPERATION - STEP-BY-STEP

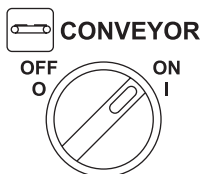
### A. Daily Startup Procedure

1. Check that the circuit breaker/fused disconnect is in the on position.

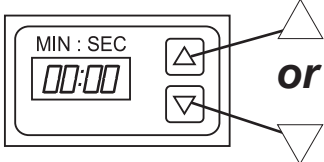
2. Turn the "BLOWER" (☸) switch to the "ON" ("I") position.



3. Turn the "CONVEYOR" (⇄) switch to the "ON" ("I") position.

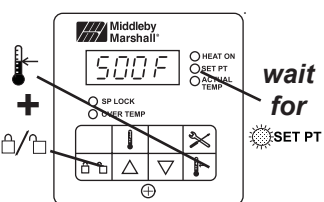


4. If necessary, adjust the conveyor speed setting by pressing the ▲ or ▼ pushbuttons on the conveyor speed controller to change the displayed bake time.

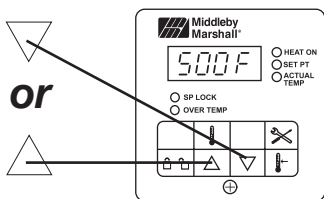


5. Adjust the temperature controller to a desired set temperature, if necessary.

- Press the Set Point and Unlock keys at the same time. Wait for the "SET PT" light to turn on.



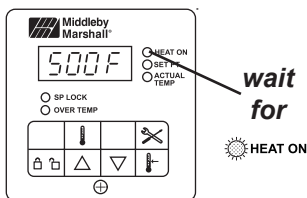
- Press the Up Arrow and Down Arrow Keys as necessary to adjust the set-point.



6. Turn the "HEAT" (☸) switch to the "ON" ("I") position, and wait for the "HEAT ON" light to turn on.

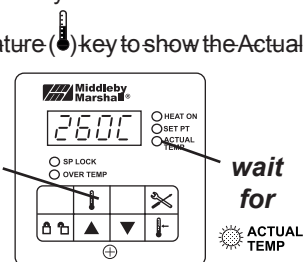


7. Wait for the oven to heat to



the setpoint temperature. Higher setpoint temperatures will require a longer wait. The oven can reach a temperature of 500°F (232°C) in approximately 15 minutes.

8. (Optional) Press the Temperature (🌡️) key to show the Actual Temperature in the display, and wait for the "ACTUAL TEMP" light to turn on. This allows you to monitor the oven temperature as it rises to the setpoint.



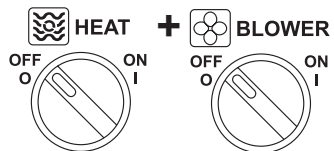
9. Allow the oven to preheat for 10 minutes after it has reached the set point temperature.

perature.

### B. DAILY SHUTDOWN PROCEDURE

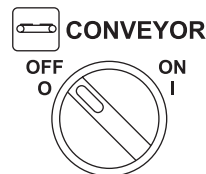
1. Turn the "HEAT" (☸) and "BLOWER" (☸) switches to

the "OFF" ("O") position. Note that the blowers will remain in operation until the oven has cooled to below 200°F (93°C).



2. Make certain that there are no products left on the conveyor inside the oven.

Turn the "CONVEYOR" (⇄) switch to the "OFF" ("O") position.



3. After the oven has cooled and the blowers have turned to the "OFF" or "O"

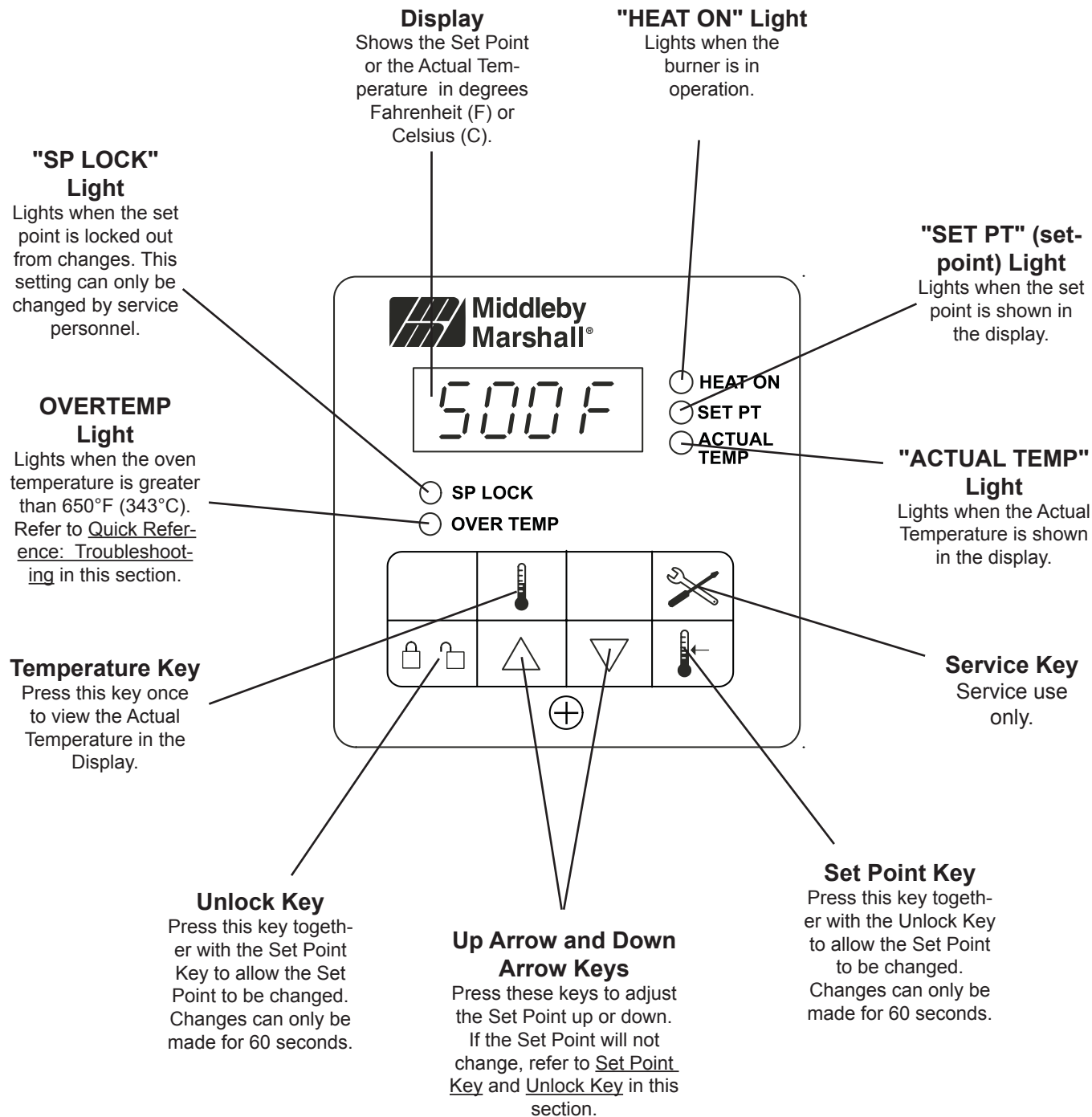
position, switch the circuit breaker/fuse disconnect to the "OFF" or "O" position.

### IMPORTANT

On gas ovens, if the "HEAT ON" light will not illuminate, OR if the oven does not heat, the gas burner may not have lit. Turn the "HEAT" (☸), "BLOWER" (☸), and "CONVEYOR" (⇄) switches to the "OFF" ("O") position. Wait for AT LEAST FIVE MINUTES before restarting the oven. Then, repeat the Daily Startup procedure.

### CAUTION



In case of power failure, turn all switches to the "OFF" ("O") position and remove the product. After the power has been restored, perform the normal startup procedure. IF THE OVEN WAS SWITCHED OFF FOR LESS THAN 5 MINUTES, WAIT FOR AT LEAST FIVE MINUTES BEFORE RESTARTING THE OVEN.





SECTION 3  
OPERATION

V. QUICK REFERENCE: TROUBLESHOOTING

SYMPTOM	PROBLEM	SOLUTION
 <b>OVERTEMP</b> <i>light is lit, food product is undercooked</i>	The oven temperature exceeded 650°F (343°C), and the burner was automatically shut down.	<ul style="list-style-type: none"> <li>Follow the procedures under <u>Daily Shutdown Procedures</u> in this section to shut down the oven. Contact your Middleby Marshall Authorized Service Agent to determine and correct the cause of the condition to prevent damage to the oven.</li> </ul>
<i>Oven will not turn on at all</i>	Electrical power may not be reaching the oven, or the controls may be set incorrectly.	<ul style="list-style-type: none"> <li>Check that the circuit breaker/fused disconnect is turned on.</li> <li>Check that the "BLOWER" (☼) Switch is in the "ON" ("I") position.</li> <li>Turn the "HEAT" (☼), "BLOWER" (☼), and "CONVEYOR" (☼) switches to the "OFF" ("O") position.</li> </ul>
 <i>appears in display, oven is not heating</i>	The oven did not reach 200°F (93°C) within 15 minutes of startup, and the oven has stopped heating.	<ul style="list-style-type: none"> <li>Wait for AT LEAST FIVE MINUTES before restarting the oven.</li> <li>Repeat the Daily Startup procedure.</li> <li>Check that the Set Point is correctly set.</li> <li>Check that both the "BLOWER" (☼) and "HEAT" (☼) Switches are in the "ON" ("I") position.</li> </ul>
<i>Oven will not heat</i>	Controls may be set incorrectly.	<ul style="list-style-type: none"> <li>If the oven still will not heat, turn the "HEAT" (☼), "BLOWER" (☼), and "CONVEYOR" (☼) switches to the "OFF" ("O") position.</li> <li>Wait for AT LEAST FIVE MINUTES before restarting the oven.</li> <li>Repeat the Daily Startup procedure. Check that the Set Point is above 200°F (93°C).</li> </ul>
<i>Oven is operating, but little or no air is blowing from air fingers</i>	Air fingers may have been reassembled incorrectly after cleaning.	<ul style="list-style-type: none"> <li>Turn the oven to the "OFF" or "O" position, and allow it to cool. Disconnect electrical power to the oven.</li> <li>Refer to Section 4, <u>Maintenance</u>, for instructions on reassembling the air fingers.</li> </ul>
<i>Conveyor moves with a jerky motion, or will not move at all</i>	Conveyor may be jammed on an object in the oven, or conveyor belt or drive chain tension may be incorrect.	<ul style="list-style-type: none"> <li>Turn the oven to the "OFF" or "O" position, and allow it to cool. Disconnect electrical power to the oven.</li> <li>Check if the conveyor is blocked by an object inside the oven.</li> <li>Refer to Section 4, <u>Maintenance</u>, for instructions on checking the conveyor and drive chain tension.</li> <li>Check that the set temperature and bake time settings are correct.</li> </ul>
<i>Food products are overcooked or undercooked.</i>	Controls may be set incorrectly.	

**IF THESE STEPS FAIL TO RESOLVE THE PROBLEM, CONTACT YOUR LOCAL MIDDLEBY MARSHALL AUTHORIZED SERVICE AGENT. A SERVICE AGENCY DIRECTORY IS SUPPLIED WITH YOUR OVEN.**

## SECTION 4 MAINTENANCE

### WARNING

Before ANY cleaning or servicing of the oven, perform the following procedure:

1. Switch off the oven and allow it to cool. Do NOT service the oven while it is warm.
2. Turn the full-flow gas safety valve to the off position.
3. Turn off the electric supply circuit breaker(s) and disconnect the electric supply to the oven.
4. If it is necessary to move a gas oven for cleaning or servicing, disconnect the gas supply before moving the oven.

When all cleaning and servicing is complete:

1. If the oven was moved for servicing, return the oven to its original location.
2. Reconnect the gas supply.
3. Reconnect the electrical supply.
4. Turn on the full-flow gas safety valve. Test the gas line connections for leaks using approved leak test substances or thick soap suds.
5. Turn on the electric supply circuit breaker(s).
6. Perform the normal startup procedure.

### WARNING

Possibility of injury from rotating parts and electrical shock exist in this oven. Turn off and lockout or tagout electrical supply to oven(s) before attempting to disassemble, clean or service oven(s). Never disassemble or clean the oven with the blower switch or any other part of the oven turned on.

### WARNING

Before performing any maintenance work or cleaning, turn main power switch off.

### CAUTION

When cleaning do not use any abrasive cleaning materials or water spray, wipe clean only. Never use a water hose or pressurized steam cleaning equipment when cleaning this oven.

### NOTICE

If the oven is to be removed from its installed location for servicing, perform the following procedure:

1. Switch off the oven and allow it to cool. Do NOT service the oven while it is warm.
2. Turn off main circuit breakers and disconnect connector from oven.
3. Move oven to desired location for servicing.
4. When servicing is complete, move oven to original location.
5. Adjust legs to level oven.
6. Connect electrical connectors to oven.
7. Turn on main circuit breakers.
8. Follow normal startup instructions.

## SECTION 4 MAINTENANCE

### I. MAINTENANCE - DAILY

#### A. Exterior

Everyday you should clean the outside of the oven with a soft cloth and mild detergent.

#### WARNING

Never use a water hose or pressurized steam cleaning equipment when cleaning the oven.

#### B. Cooling Fan

1. ONE COOLING FAN GRILLE AT THE REAR OF THE OVEN MUST BE CLEANED DAILY - Clean grille with a stiff nylon type brush.
2. Check the air intake of the cooling fan daily. The best time to check is right after starting the oven.

#### IMPORTANT NOTE

The cooling fan operates when the blower switch is turned to "ON" ("I"). It must operate to keep the electrical control cabinet below 140°F (60°C).

#### WARNING

IF FAN BLADE IS NOT ROTATING, BROKEN, OR FAN ASSEMBLY IS MISSING FROM MAIN BLOWER MOTOR SHAFT, DO NOT OPERATE OVEN. REPLACE COOLING FAN BLADE BEFORE OPERATING OVEN. Serious damage could be done to the burner blower motor and/or solid-state electrical components if oven is operated while cooling fan is not running or vent grille is plugged.

3. Using a stiff nylon brush clean control compartment vent grille.

#### C. Conveyor Belt (Figure 4-2)

Everyday, just after starting the oven, stand at the unloading end of the conveyor, and with a brush, remove food particles (crumbs, etc.) clinging to the conveyor belt, brushing them into the crumb pan.

#### D. Crumb Pans (Figure 4-2)

#### WARNING

Crumb pan is extremely hot while oven is operating. Allow oven to cool before removing crumb pan.

When the oven is cool remove and clean the crumb pan at each end of the oven. Each crumb pan can be removed by sliding it out, as shown in Figure 4-2. Reinstall the crumb pans after cleaning.

### II. MAINTENANCE - MONTHLY

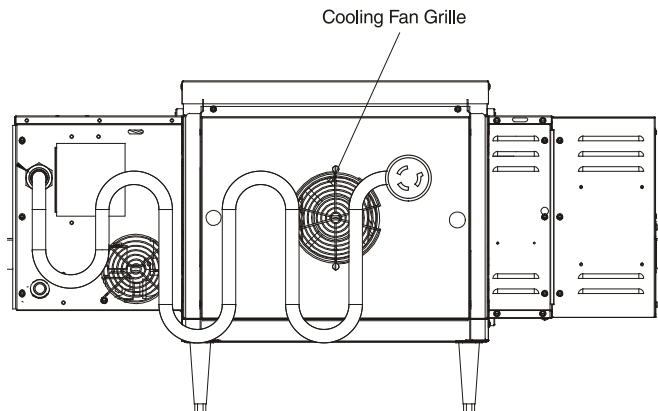


Figure 4-1. Oven Cooling Fans

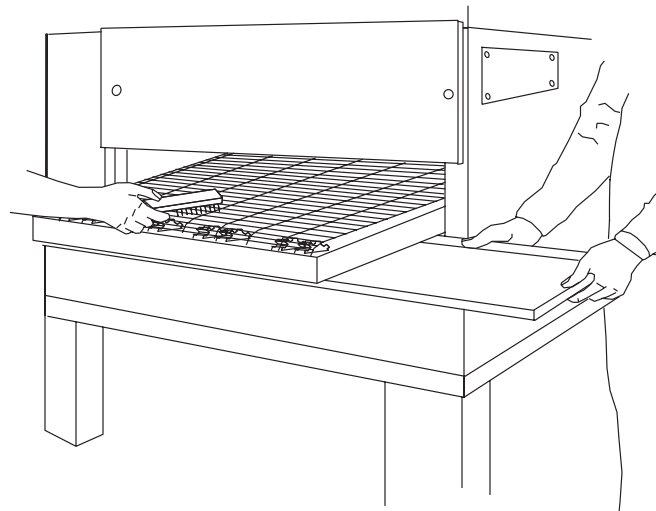


Figure 4-2. Conveyor Belt and Crumb Pan Cleaning

**NOTE: The oven interior may require cleaning more than once a month depending on the volume of baking. To clean the interior, you have to disassemble some parts of the oven.**

When cleaning your Series PS528 Oven note the following:

**PRECAUTIONS-**

1. Do not use excessive water or saturation of oven insulation will occur.
2. Do not use a caustic oven cleaner or the aluminized finger manifold surfaces will be severely damaged.

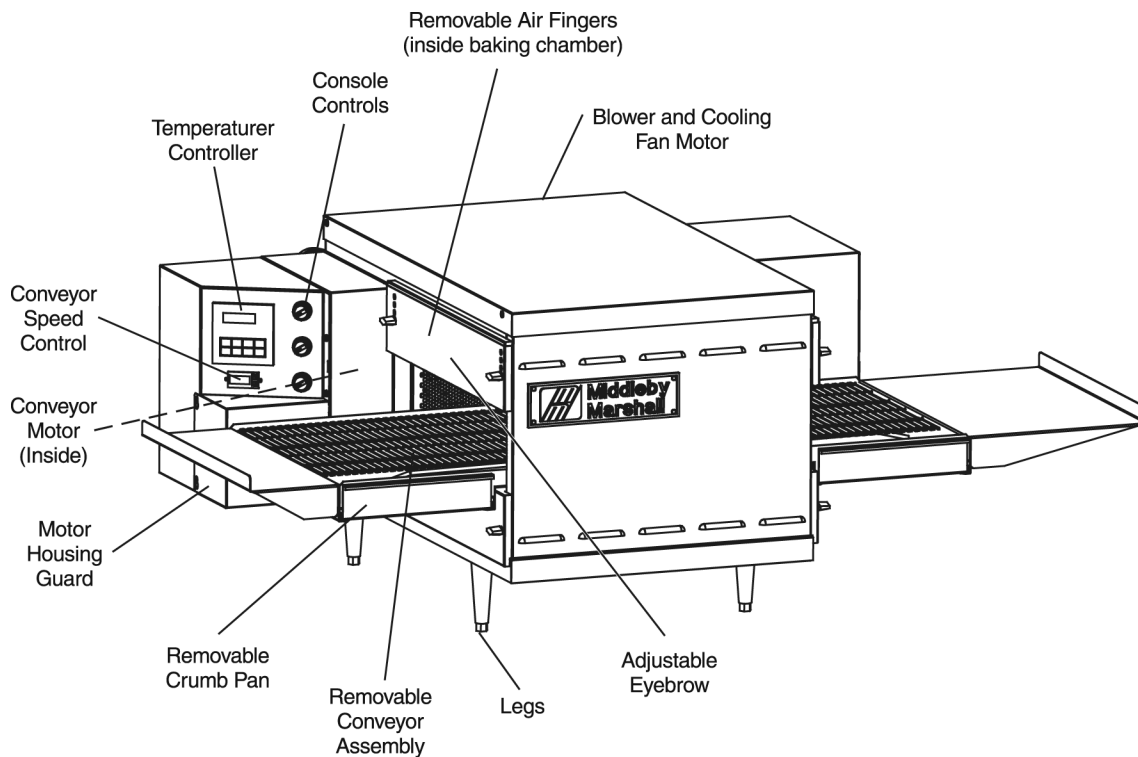
When cleaning your oven, first remove all heavy debris with a vacuum cleaner. Use a damp cloth for light cleaning. For heavier cleaning of baked on grease and carbon deposits use a non-caustic cleaner that will not react with the aluminized finger manifold surfaces.

You can order non-caustic cleaner from your local authorized Middleby Marshall Parts Distributor in the quantities listed:

Part #	Quantity
27170-0244	Case of Quarts (6)
27170-0246	Case of Gallons (4)

**A. Removing Conveyor From Oven For Cleaning**

1. Remove entry and exit trays.
2. Loosen (do not remove) two screws on housing guard.
3. Remove motor housing guard.
4. Lift conveyor and remove chain.
5. Lift other side of conveyor and push toward other



**Figure 4-3.**

SECTION 4  
MAINTENANCE

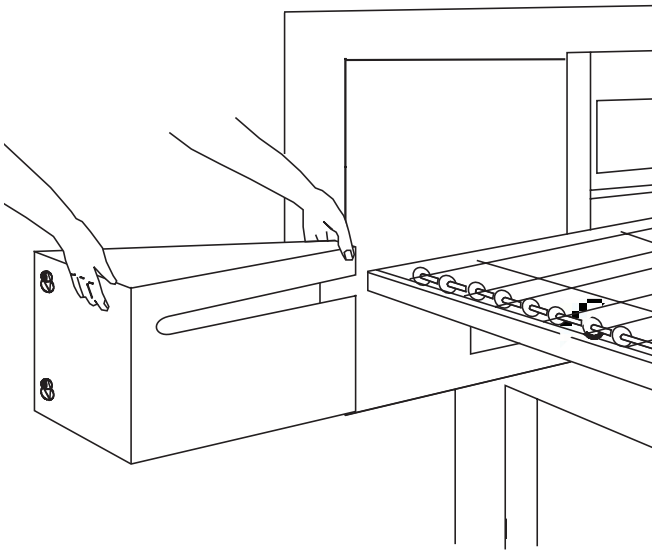


Figure 4-4.

side.

6. Remove conveyor as shown.

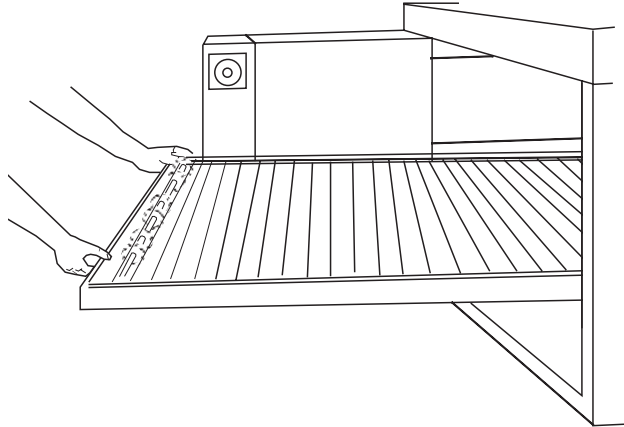


Figure 4-6.

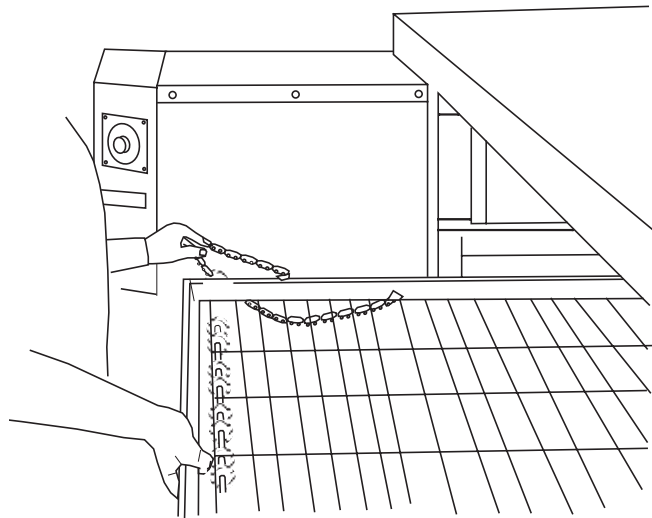


Figure 4-5.

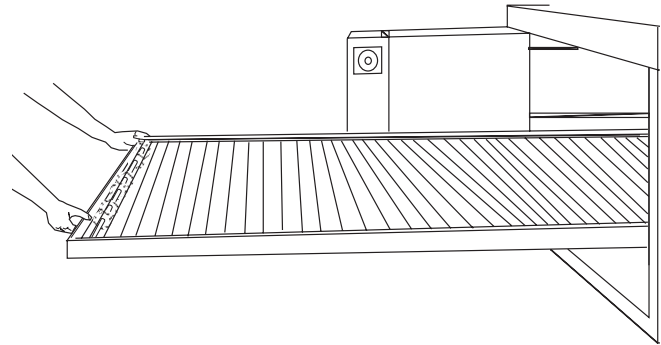


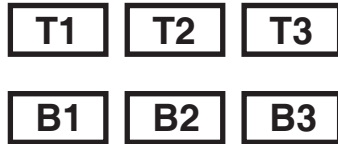
Figure 4-7.

**CAUTION**

Be careful not to bump the drive sprocket while handling the conveyor, to avoid damaging the drive shaft.

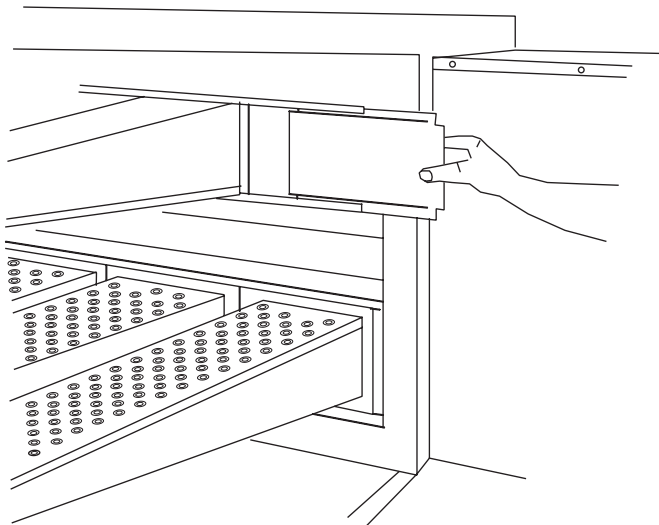
**B. Air Fingers Disassembly For Cleaning**

1. As the air fingers are removed use a felt pen to mark all parts of the fingers. This includes the finger manifold, inner plate and the outer plate (refer to Figure 1-9). If a blank or choke plate is used, mark that plate also. Fingers are marked in the order shown; as viewed from the front of the oven. (The marks for an upper oven should be preceded with a "U", example UB1, UT2, etc.)



**Standard Fingers**

2. Slide blank plates straight out.



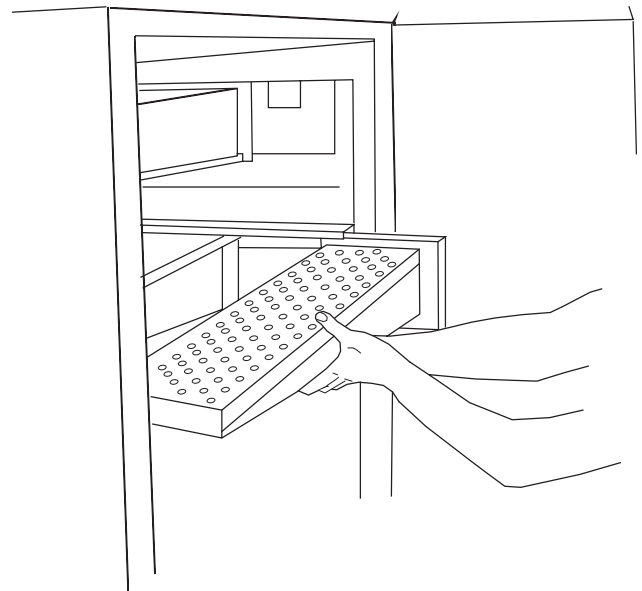
**Figure 4-8.**

3. Remove air fingers.

**NOTE:** Some oven users require a custom finger arrangement where the quantity of air fingers may vary.

You can remove top and bottom fingers and blank plates from each or either end. It is highly recommended that each finger be marked before removing so it is placed in exactly the same position when reassembled (refer to step 1).

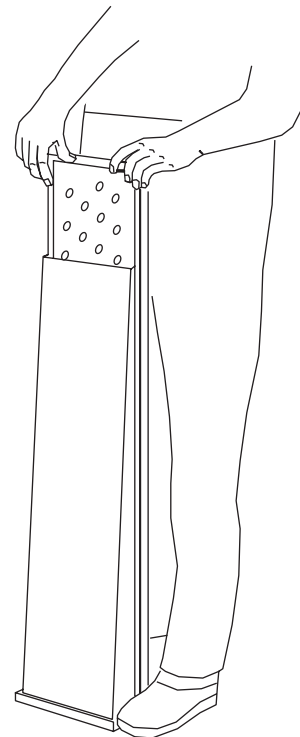
Remove the air fingers, pull the finger at the back side - pull straight out.



**Figure 4-9.**

4. With air fingers out, place them in an upright position to remove the outer plate.

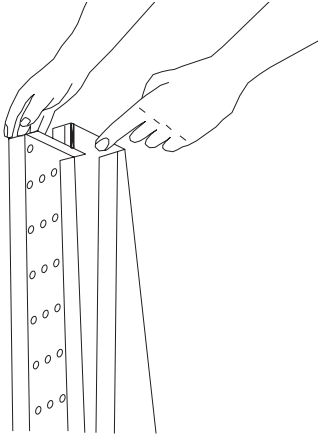
5. Gently step on the lip of the finger and pull the outer plate off.



**Figure 4-10.**

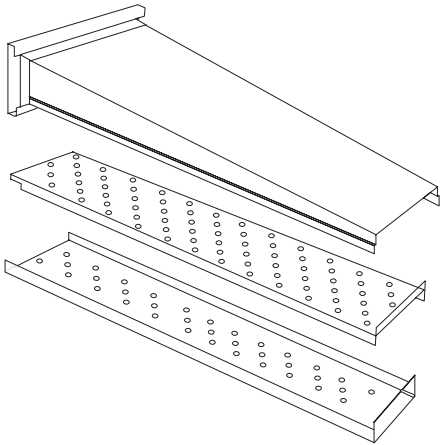
## SECTION 4 MAINTENANCE

6. To remove the inner plate, pull the plate out and then up.

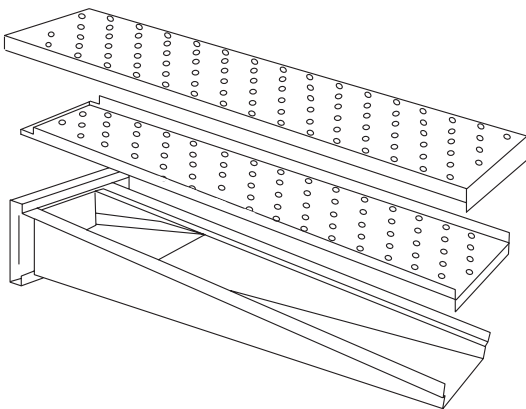


**Figure 4-11.**

7. The outer finger plate is stainless and may be cleaned by either soaking in a hot, strong detergent solution or using a caustic cleaner. The conveyor belt can also be cleaned in the same way.



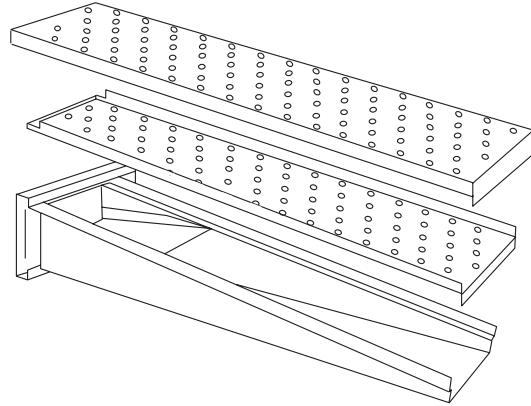
**Figure 4-12. Standard Lower Finger**



**Figure 4-13. Standard Upper Finger**

### C. Reassembly of Air Fingers

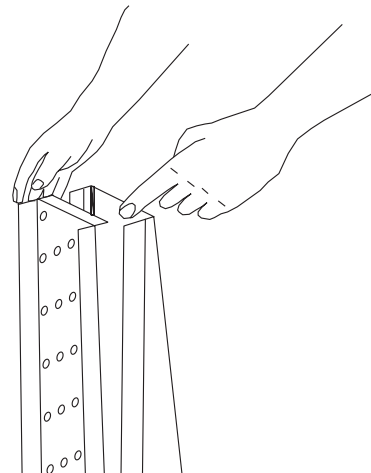
1. Air fingers are made up of one inner plate, one outer plate and the finger housing manifold. Be sure to match up the markings (T1, T2, T3, etc.) on all the parts of the air fingers as you are reassembling.



**Figure 4-14.**

2. Reassemble the inner plate. Keep your fingers clear so you won't pinch them. The inner plate of a finger will only go in one way because of its design.

3. Replace the outer plate by placing your hands flat on the top of the plate and pushing down. Keep your fingers clear so you won't pinch them.



**Figure 4-15.**



4. Replace the air fingers by pushing in at the back side. Remember to replace them according to the numbers marked on them when they were removed. They must go back in the same way they came out.

**IMPORTANT:** When inserting fingers the tab on the outer plate must be in the groove as shown in Figure 4-18. There is a blocking tab on the outside of the groove which will prevent inserting the finger in the groove if the outer plate is moved away from the flange of the finger manifold.

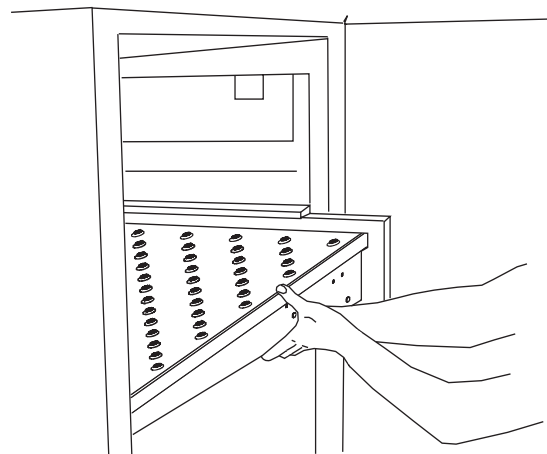


Figure 4-16.

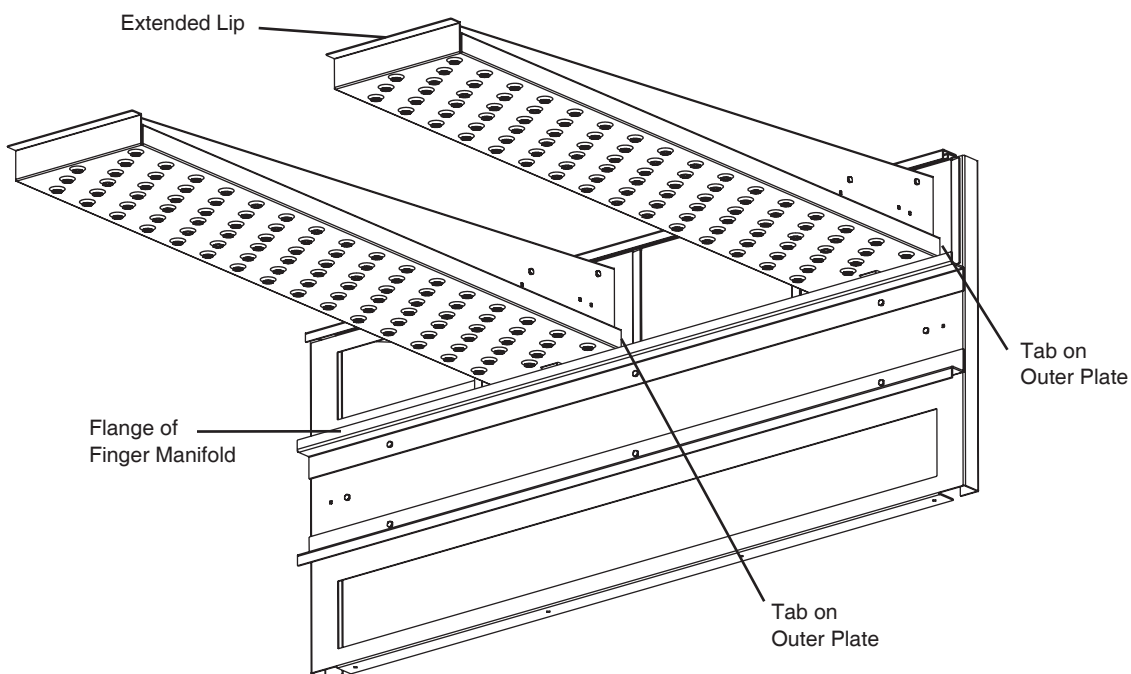


Figure 4-17.

SECTION 4  
MAINTENANCE

5. Install fingers and blank plates correctly with edges interlocked and no space between edges.

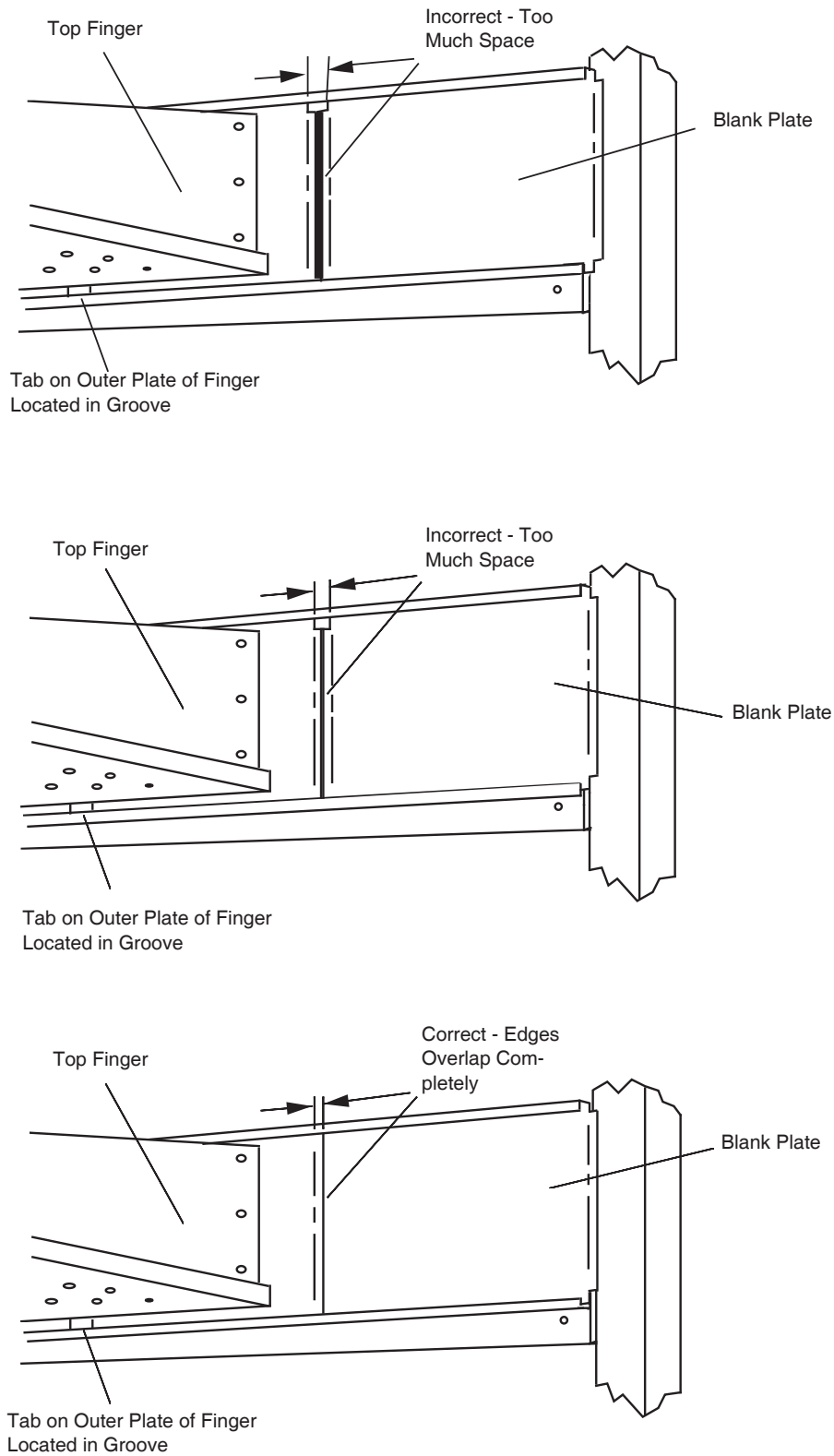
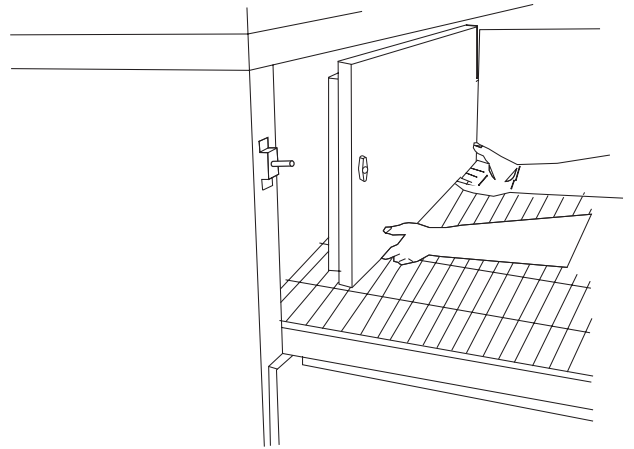


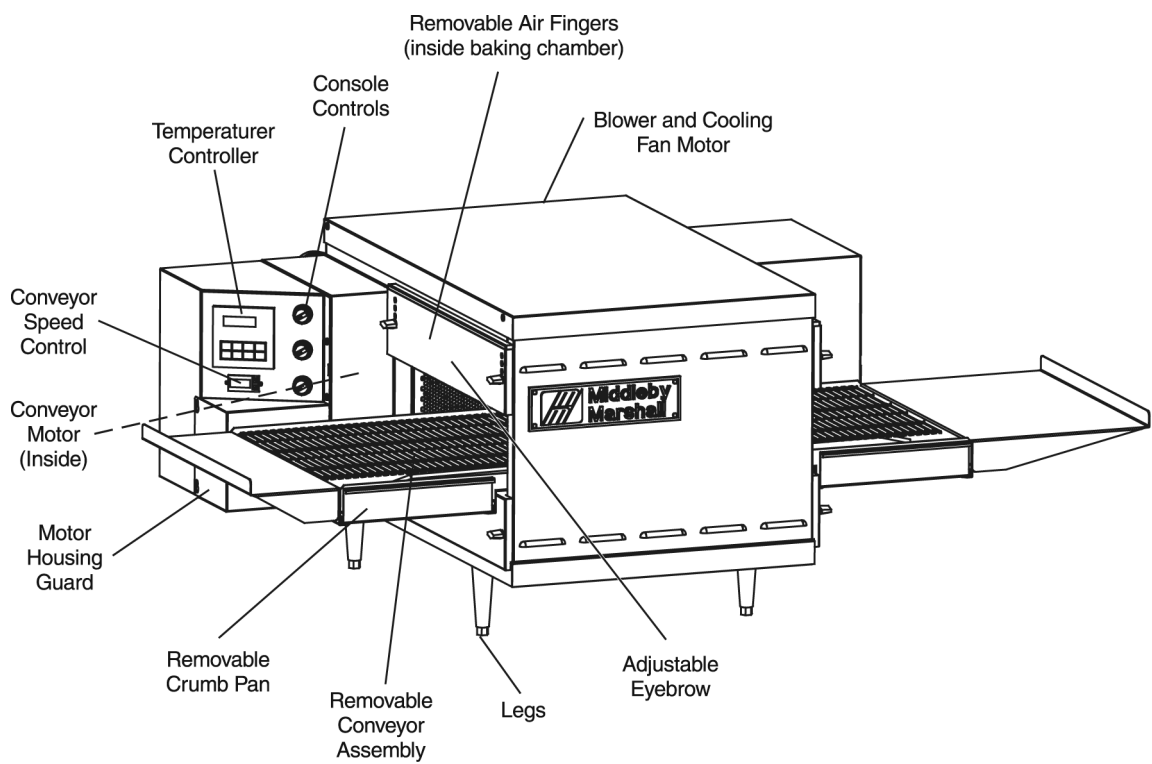
Figure 4-18.

**D. Reinstall End Plugs**

1. Reinstall lower end plug. Be sure to tighten the wing screw on the end plug.
2. Reinstall conveyor.
3. Reinstall upper end plug. Be sure to tighten two wing screws on the end plug.



**Figure 4-19.**



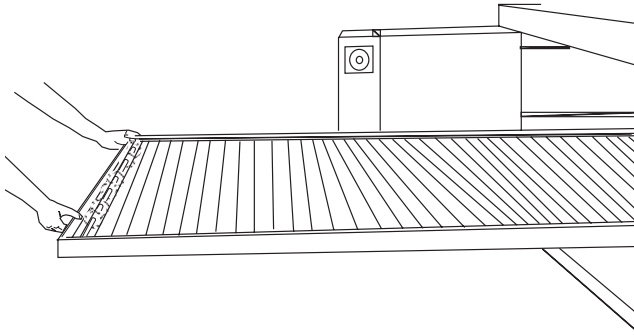
**Figure 4-20.**

## SECTION 4 MAINTENANCE

### E. Conveyor Reassembly Into Oven

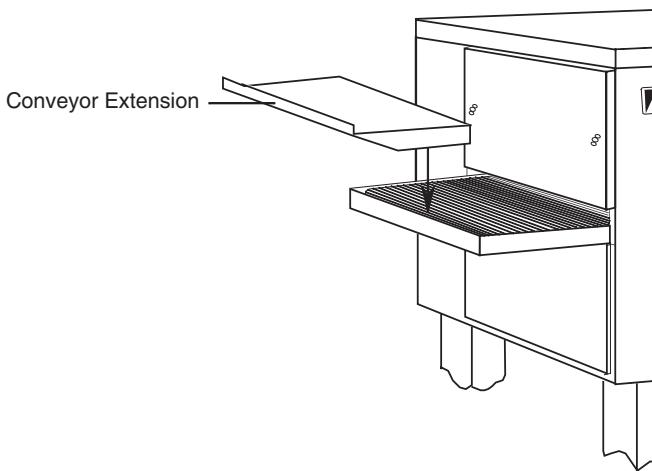
1. Lift conveyor and position it in oven as shown.

**NOTE:** Conveyor may be inserted into either end of oven. If it is to be installed from the non-drive end of the oven the drive sprocket assembly must be removed as shown in conveyor disassembly section.



**Figure 4-21.**

2. Reinstall the conveyor extension.



**Figure 4-22.**

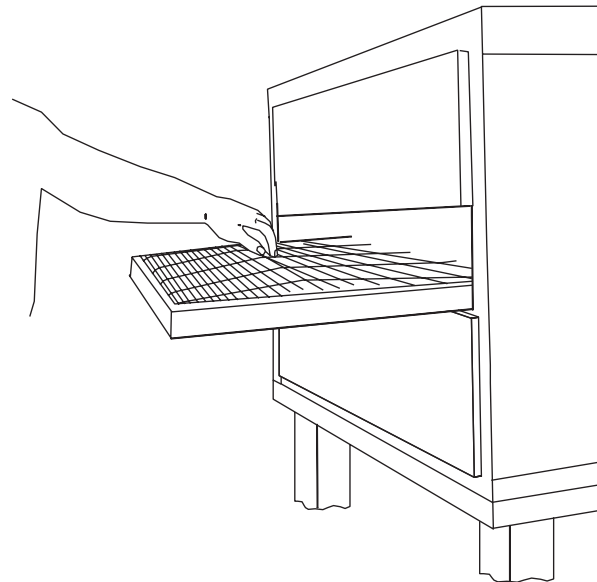
### F. Checking Conveyor Belt Tension

#### **WARNING**

Oven conveyor belt must be cool when adjusting belt. Do not adjust belt if HOT.

1. With the conveyor assembly in the oven, stand at one end of conveyor and check tension by lifting the conveyor belt at the center of the oven chamber opening. The belt should not lift higher than 1" to 2" (75mm to 102mm).
2. If conveyor belt is still not under proper tension, an entire link must be removed. Use the following procedure "H. Conveyor Belt Link Removal" to remove a link. If conveyor belt is under proper tension proceed directly to "J. Attaching Drive Chain".

**Figure 4-23.**



### G. Conveyor Belt Link Removal

1. Using long nose pliers, an entire link can be removed with the conveyor assembly either in or out of the oven. Position master links at end of conveyor as shown in Figure 4-24.

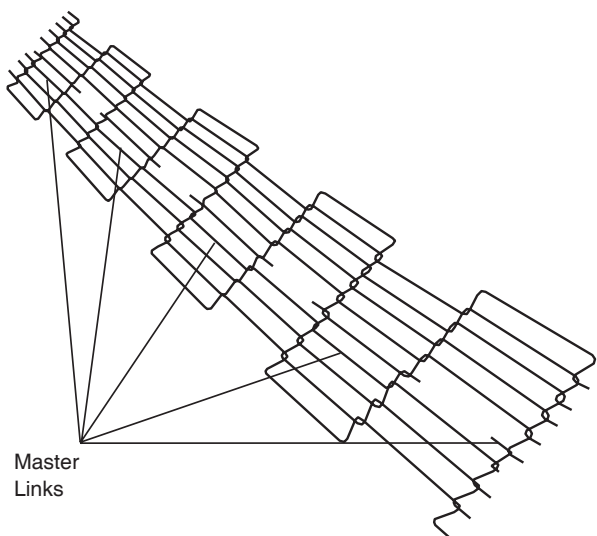


Figure 4-24.

2. Using long nose pliers, unhook master links at left end of conveyor as shown in Figure 4-25.

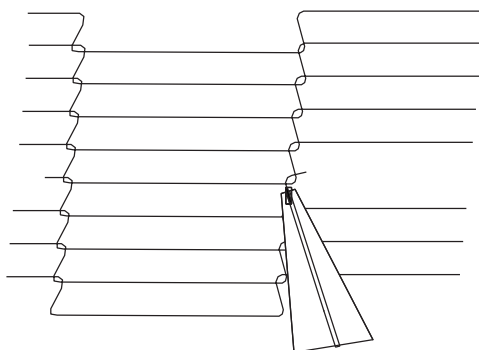


Figure 4-25.

3. Remove the outside master links on the right and left sides of the conveyor belt as shown in Figure 4-26.

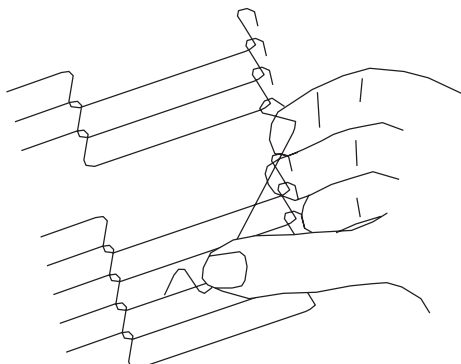


Figure 4-26.

4. Unhook the link to be removed.

5. Pull up on the belt link section and remove. Do not discard the link removed as it may be used for making spare master links.

**NOTE:** If a section of the conveyor belt is being replaced it should be done now. Remove the links that need replacing and use the section of conveyor belt furnished in your installation kit to replace them.

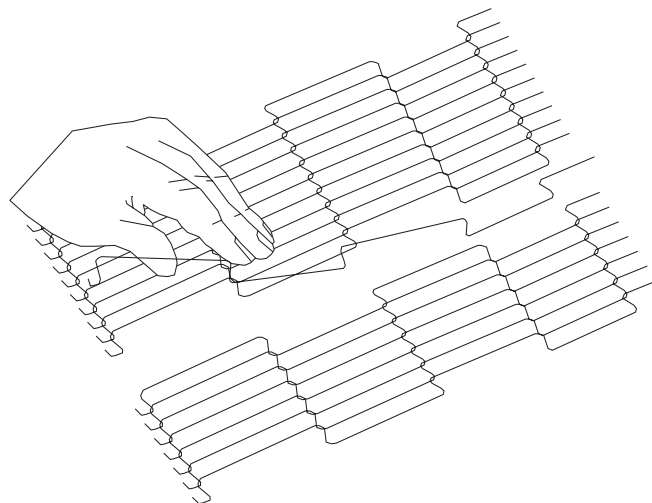


Figure 4-27.

**NOTE:** Before connecting the inside master links, notice that these links have a correct position (Figure 4-28). The link at the right is in the correct (horns up) position for inserting into the conveyor belt. The horns facing down are in the incorrect position.

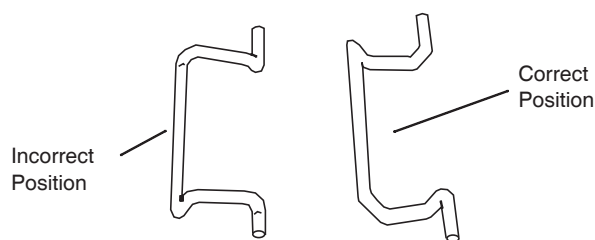
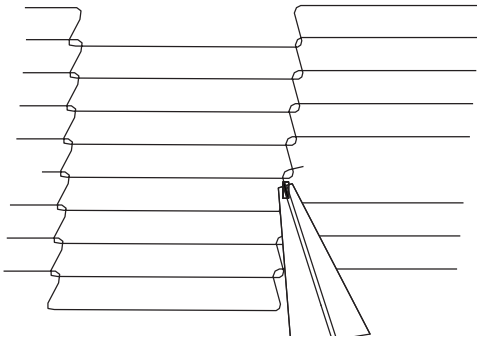


Figure 4-28.

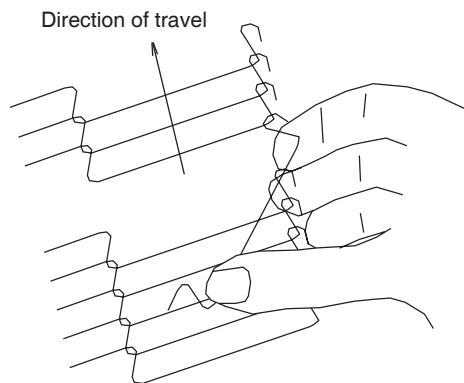
## SECTION 4 MAINTENANCE

6. Reconnect the inside master links (Figure 4-29.)



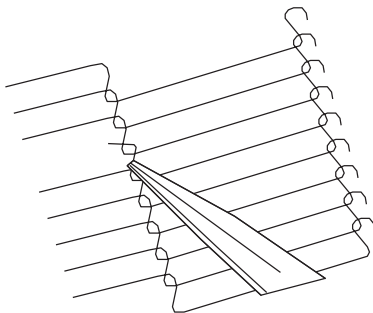
**Figure 4-29.**

**NOTE:** The outside master links have right and left sides to them. The right edge master link has an open hook facing you as shown in Figure 4-30. This will match up with the outer edges of the conveyor belt. Remember this hook travels backwards on the conveyor.



**Figure 4-30.**

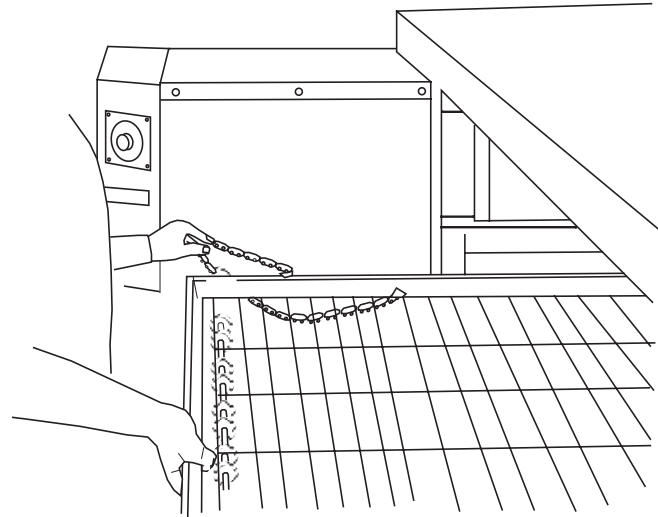
7. Reconnect the outside master links.
8. Replace all parts removed from the oven.



**Figure 4-31.**

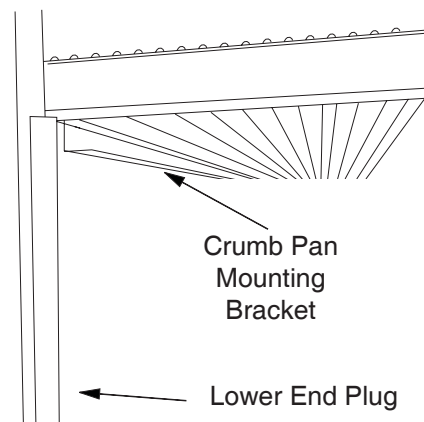
### H. Attaching Drive Chain

1. If drive sprocket assembly was removed reassemble it into the conveyor drive shaft. Be sure flat on end of drive shaft aligns with set screw in conveyor shaft collar. Once in place tighten 3/32" set screw.
2. Lift conveyor and install drive chain to conveyor drive sprocket and motor sprocket.



**Figure 4-32.**

3. The angle plate located on the underside of the conveyor must be against the lower end plug. This is true on both sides of oven.



**Figure 4-33.**

4. Reattach conveyor guard to control panel and secure two screws.

Install both upper end plugs.

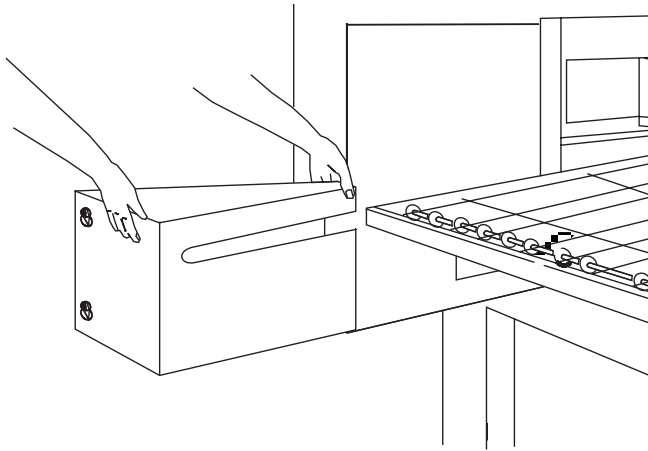


Figure 4-34.

#### A. Electrical Terminals

Open the control cabinet door by removing the three screws from the control cabinet door. Tighten all electrical control terminal screws including the electrical contactor terminal screws as shown in Figure 4-35.

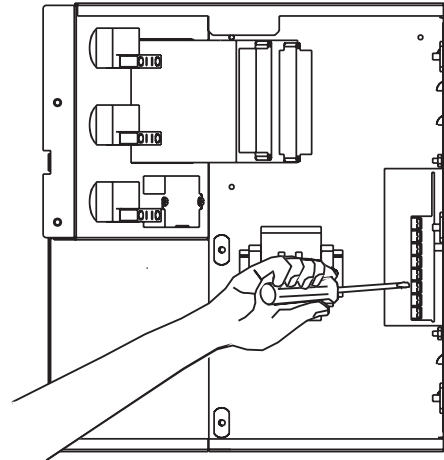


Figure 4-35.

### III. MAINTENANCE - EVERY 3 MONTHS

#### WARNING

Shut OFF all electrical power and lock/tag out the switch before attempting maintenance work.

**NOTE:** It is recommended that the 3-month maintenance be performed by an authorized Middleby Marshall technician.

#### B. Ventilation

Check that the air circulation throughout the oven is not blocked and is working properly.

### IV. MAINTENANCE - EVERY 6 MONTHS

A. Check brushes on D.C. conveyor motor, when worn to less than 1/10" (2.4mm), replace the brushes.

B. Check your oven venting system.

C. Inspect and clean the burner nozzle and the spark electrode assembly.

#### IMPORTANT NOTICES:

- Installation of replacement parts requiring access to the interior of the oven is permitted only by an authorized service technician.
- If there are any problems with the operation of the oven, the authorized service technician must be called.
- It is suggested to obtain a service contract with a manufacturer's authorized service technician.

SECTION 4  
MAINTENANCE

**KEY SPARE PARTS KIT**

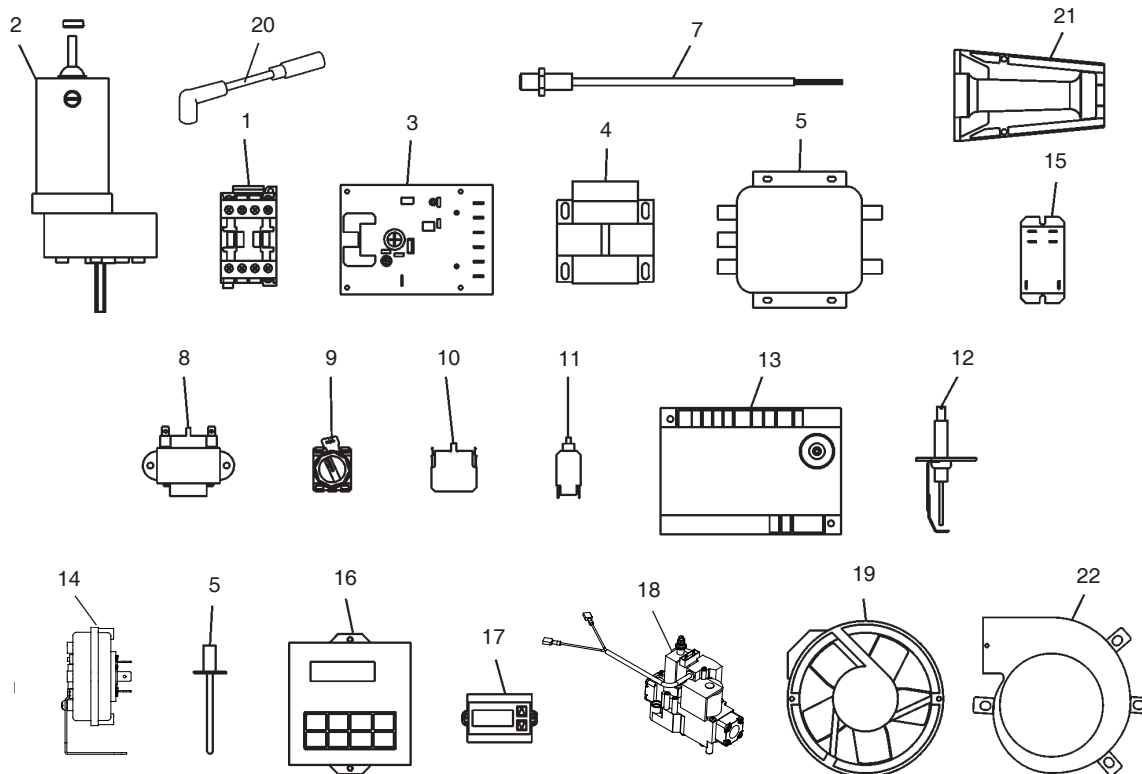
An oven can be purchased with a Key Spare Parts Kit (Figure 4-36). (The kit can be purchased when the oven is ordered, or later, from a Middleby Marshall Authorized Parts Distributor). The kit contains many of the crucial

parts that can reduce serious downtime and loss of production, if a failure occurs.

Replacement parts for this kit can be purchased from your Middleby Marshall Authorized Parts Distributor.

**PS528-SERIES GAS OVEN KEY SPARE PARTS KIT (Figure 4-36)**

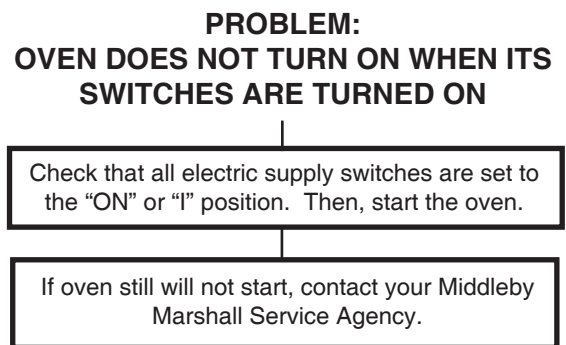
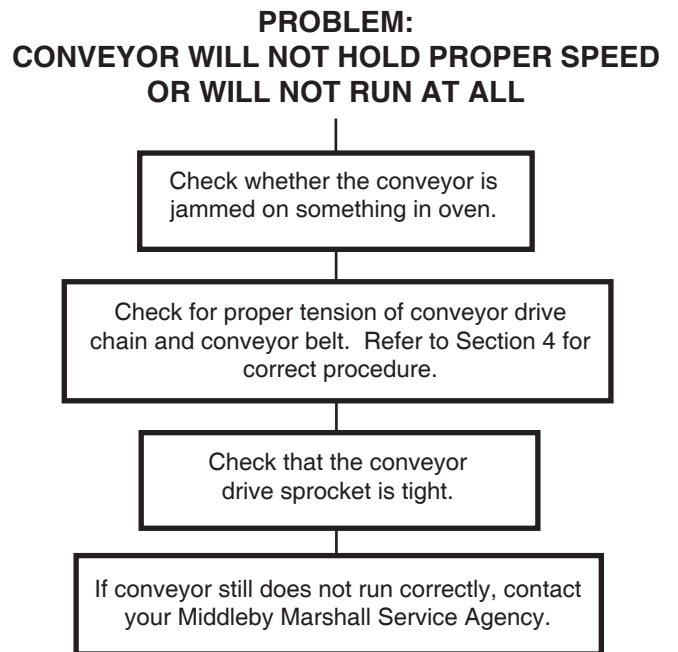
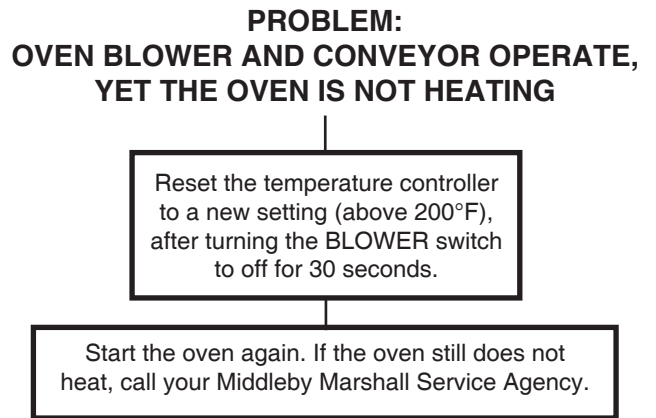
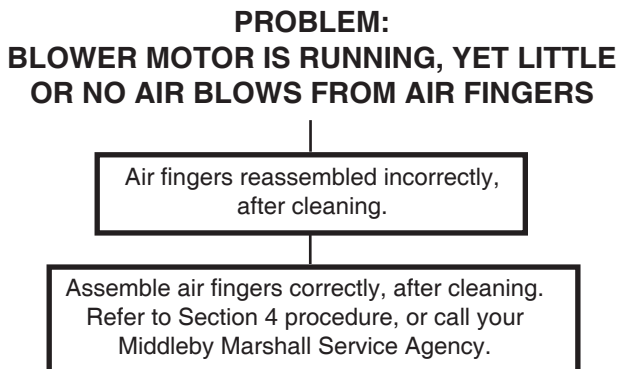
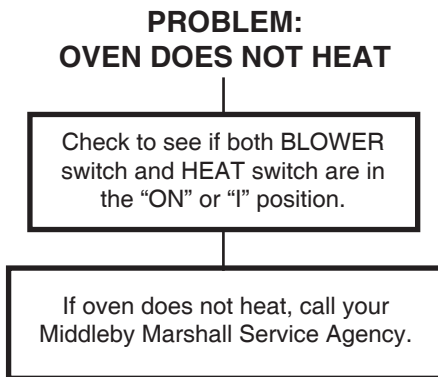
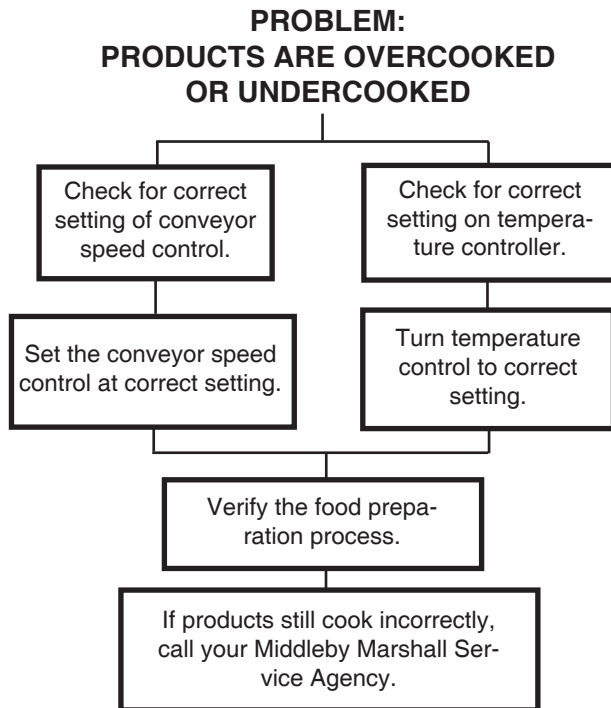
ITEM	PART NO.	ENGLISH DESCRIPTION	QUANTITY
1	28041-0011	Contact, DP 25A 208/240V	1
2	58390	Motor, Conveyor Drive w/Magnet	1
3	60671	Board, Amplifier Signal, 0-15VDC	1
4	32108	XFMR, 240V PRI 24V 65VA SEC	1
5	33812-5	Thermocouple, Type "J" Shielded 2.50 x 120	3
6	33813	Filter, RFI	1
7	38185	Assembly, Pickup Sensor	1
8	41872	Transformer, 240V (P), 24V (S) 25VA	1
9	44696	Switch, Rotary and Mounting Adapter	2
10	44697	Block, Contact	3
11	45644	Breaker, Circuit 240V 1A	1
12	48455	Ignitor, Single Rod	1
13	61602	Ignition, Spark Module 24VAC 50/60 Hz	1
14	62044	Switch, Air .08" WC	1
15	50794	Relay, 240VAC 2P1S	1
16	47321	Control, Combo 4-20MA, Burst	1
17	60542	Controller, Digital w/o Dip Switch	1
18	60679	Valve, Gas PS528	1
19	36451	Fan, Cooling 230VAC 295 CFM	1
20	62282	Ignition Cable, 25"	1
21	59002	Inshot Burner	2
22	62106	Main Blower	2



**Figure 4-36.**

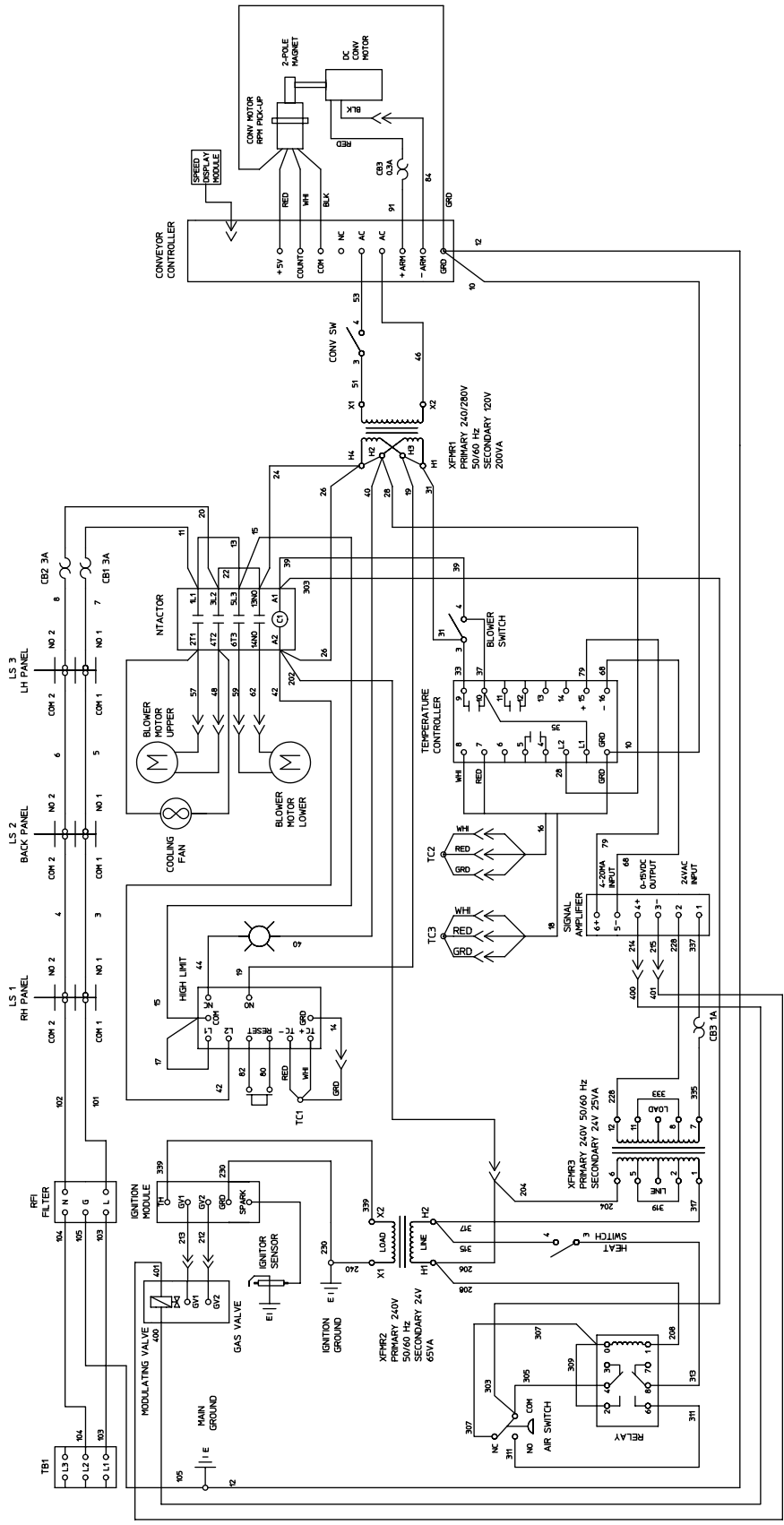


## SECTION 5 TROUBLESHOOTING



## NOTES

# SECTION 6 ELECTRICAL SCHEMATICS



Wiring Diagram, G208-240 50/60 GO, PS528G • P/N 62317 REV B

## **WARNING**

**Improper installation, adjustment, alteration, service or maintenance can cause property damage, injury or death. Read the installation, operating and maintenance instructions thoroughly before installing or servicing this equipment.**

### **NOTICE**

During the warranty period, ALL parts replacement and servicing should be performed by your Middleby Marshall Authorized Service Agent. Service that is performed by parties other than your Middleby Marshall Authorized Service Agent may void your warranty.

### **NOTICE**

Using any parts other than genuine Middleby Marshall factory manufactured parts relieves the manufacturer of all warranty and liability.

### **NOTICE**

Middleby Marshall reserves the right to change specifications at any time.

# **CFESA**

**Commercial Food Equipment Service Association**

Middleby is proud to support the Commercial Food Equipment Service Association (CFESA). We recognize and applaud CFESA's ongoing efforts to improve the quality of technical service in the industry.

Middleby Cooking Systems Group • 1400 Toastmaster Drive • Elgin, IL 60120 • USA • (847)741-3300 • FAX (847)741-4406

***[www.middleby.com](http://www.middleby.com)***



## Free Manuals Download Website

<http://myh66.com>

<http://usermanuals.us>

<http://www.somanuals.com>

<http://www.4manuals.cc>

<http://www.manual-lib.com>

<http://www.404manual.com>

<http://www.luxmanual.com>

<http://aubethermostatmanual.com>

Golf course search by state

<http://golfingnear.com>

Email search by domain

<http://emailbydomain.com>

Auto manuals search

<http://auto.somanuals.com>

TV manuals search

<http://tv.somanuals.com>