

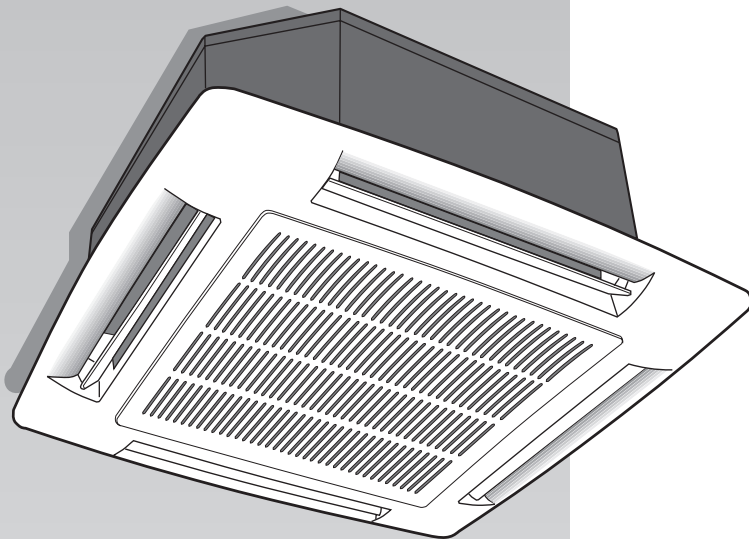

---

**42GW**

---

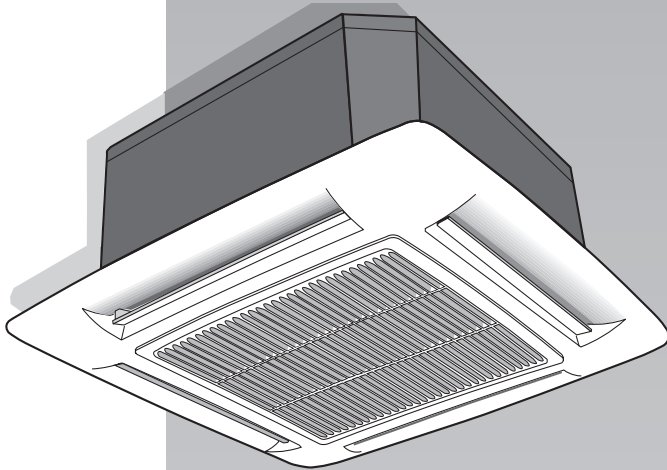

---

**INSTALLATION MANUAL**

---

# 42 GW

## “Hydronic Global Cassette” Fan Coil Units

### Contents

	Page
Dimensions and weights .....	2
Technical data .....	3
General information .....	4
Avoid .....	5
Installation .....	6/8
Water connections .....	8
Motorized valve and control .....	9/11
Electrical connections .....	11/12
Wiring diagram .....	13
Fresh air renewal and conditioned air supply to adjacent room .....	14/15
Maintenance .....	16

Models C = 2-pipe D = 4-pipe	Models C = 2-pipe D = 4-pipe	Models with electric heater	Power supply
42GWC004	42GWC004H	42GWE004	230V ~ 50Hz
42GWC008	42GWC008H	42GWE008	
42GWC010	42GWC010H	42GWE010	
42GWC012	42GWC012H	42GWE012	
42GWC016	42GWC016H	42GWE016	
42GWC020	42GWC020H	42GWE020	
42GWC020	42GWC020H	42GWE004H	
42GWD004	42GWD004H	42GWE008H	
42GWD010	42GWD010H	42GWE010H	
42GWD010	42GWD010H	42GWE012H	
42GWD020	42GWD020H	42GWE016H	
		42GWE020H	
		42GWH004	
		42GWH008	

# 42 GW

## Dimensions and weights

**42GW**  
**004 - 008 - 010**

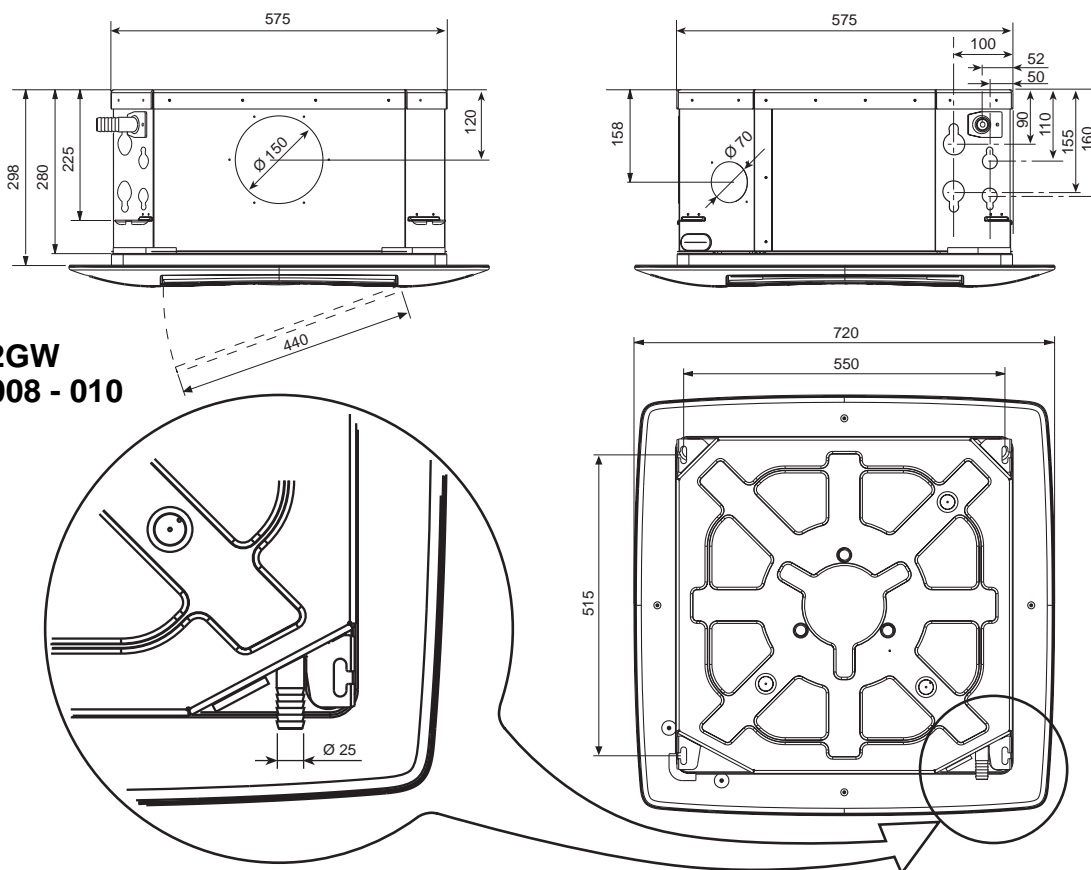

**42GW**  
**012 - 016 - 020**

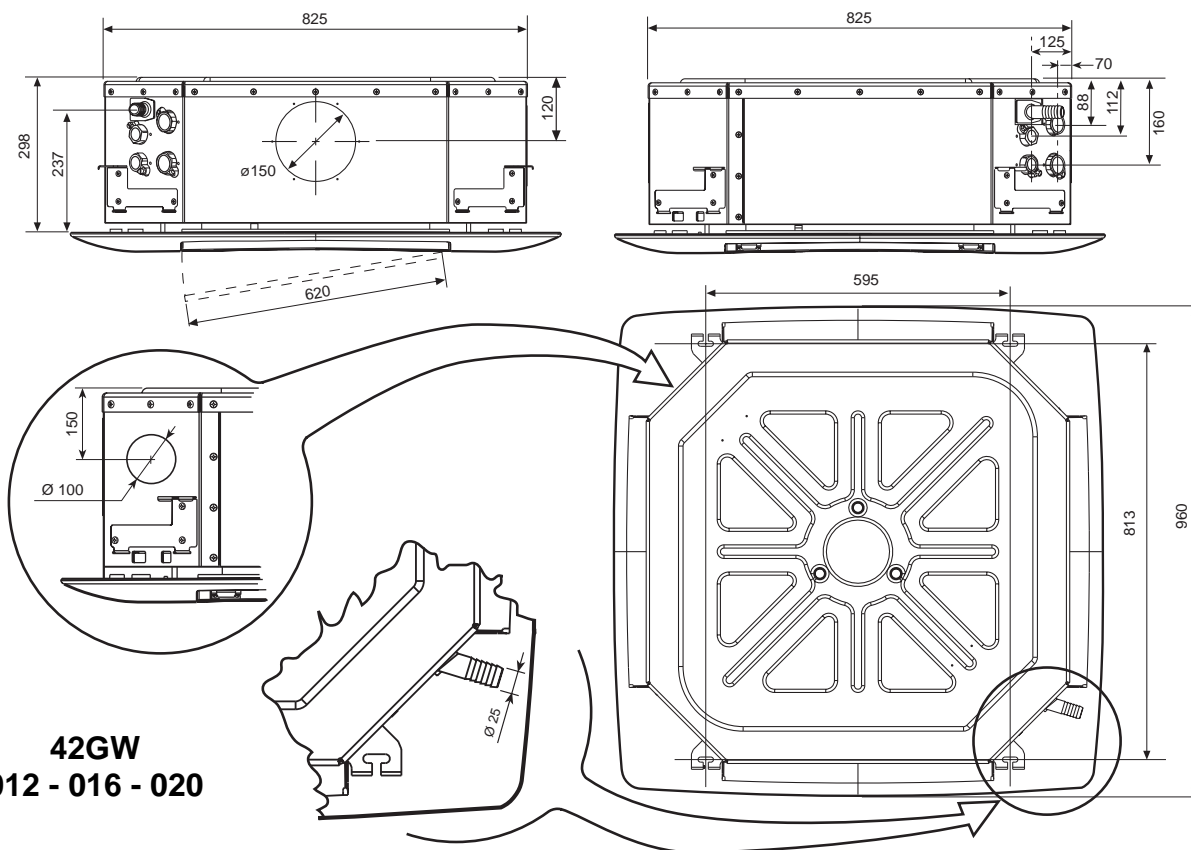

42GW	kg	004	008	010	012	016	020
Unit			17.5	19	19	36	38
Frame/Grille assembly		3	3	3	5	5	5

**Table I: Nominal data**

POWER INPUT					
Models		Cooling		Heating	
		W	A	W	A
42GWC008	42GWC008H	78	0.34	68	0.29
42GWC010	42GWC010H	100	0.43	90	0.39
42GWC012	42GWC012H	97	0.42	87	0.38
42GWC016	42GWC016H	135	0.58	125	0.54
42GWC020	42GWC020H	197	0.85	187	0.81
42GWD004	42GWD004H	66	0.28	56	0.24
42GWD010	42GWD010H	100	0.43	90	0.39
42GWD020	42GWD020H	197	0.85	187	0.81

Note: 230V ~ 50Hz.

Models	POWER INPUT			
	Cooling		Heating	
	W	A	W	A
42GWE004	70	0.30	1560	6.8
42GWH004	70	0.30	560	2.4
42GWE008	65	0.28	2555	11.1
42GWH008	65	0.28	555	2.4
42GWE010	94	0.40	2584	11.2
42GWE012	123	0.53	3113	13.5
42GWE016	141	0.61	3131	13.6
42GWE020	233	1.00	3223	14.0
42GWE004H	70	0.30	1560	6.8
42GWE008H	65	0.28	2555	11.1
42GWE010H	94	0.40	2584	11.2
42GWE012H	123	0.53	3113	13.5
42GWE016H	141	0.61	3131	13.6
42GWE020H	233	1.00	3223	14.0

**Table II: Wire section of connecting cable mm<sup>2</sup>**

Models	L/R	N/C
from 004 to 020	1.0	1.0

- The power cable to the electrical heaters must be type H07 RN-F.
- The unit power cable must be type H07 RN-F.

**Table III: Technical data of electric heaters (if installed)**

Mod.	004	H004	008	H008	010	012	016	020	
Electric heater capacity	kW	1.5	0.5	1.5+1.0	0.25+0.25	1.5+1.0	2x1 + 2x0.5		
Supply voltage (ph)	V	230 (1 ph)	230 (1 ph)	230 (*)	230 (1 ph)	230 (*)	400	400	400
Max. power input	A	6.50	2.1	10.8	2.1	10.8	7.5	7.5	7.5
Safety thermostat	N° 1 Thermostat with automatic reset ST1 60°C N° 1 Thermostat with manual reset(electric) ST2 100°C								
Power supply cables	mm <sup>2</sup>	3 x 1.5	3 x 1.5	3 x 2.5	3 x 2.5	3 x 2.5	5 x 1.5	5 x 1.5	5 x 1.5
Recommended fuse (Type gL)	A	8	8	12	12	12	10	10	10

**IMPORTANT:**  
The electric heater must always be factory installed (mod. 42GWE/H...).  
The use of other electric heaters is absolutely prohibited.  
Failure to follow this safety requirement causes unit damage and voids the warranty.

(\*) In areas with a 2 kW limit for single-phase electric heaters it is possible to divide the power supply on two phases and neutral of a three phase supply with neutral.  
Use cable type H07 RN-F - 4 x 1.5 mm<sup>2</sup> - 400V 2N-

**Table IV: Material supplied**

Description	Q.ty	Use
Installation instructions	1	Unit installation
Fresh air intake baffle	1	Air renewal

**Table V: Operating limits**

Water circuit	Water- side maximum pressure 1400 kPa (142 m w.c.)	Minimum entering water temperature: + 4°C
		Maximum entering water temperature: + 80°C
Room air		Minimum temperature: 5°C (1)
		Maximum temperature 32°C
Power supply	Nominal single phase voltage Operating voltage limits	230V ~ 50Hz min. 198V – max. 264V
	Nominal three phase voltage Operating voltage limits	400V 3N~ 50Hz min. 342V – max. 462V
		60Hz Special Export Market min. 187V – max. 253V

**Notes:** (1) If the room temperature can go down to 0°C, it is advisable to empty the water circuit to avoid damage caused by ice (see paragraph on water connections).

**Table VI: Accessories**

Description	Size / Code	
	004-008-010	012-016-020
2-pipe valve	42GW9003	42GW9007
4-pipe valve	42GW9004	42GW9008
Primary air	42GW9005	42GW9006
Air disch. closing *	40GK-900---003-40	40GK-900---013-40
Active carbon filter	40GK-900---002-40	40GK-900---012-40
Electrostatic filter	40GK-900---001-40	40GK-900---011-40
Drain pan	42GW9009	42GW9010

Description	Size / Code
	004-008-010-012-016-020
Water discharge pump	40GKX9001
Control	42GW9014
Control	42GW9015
Control	42GW9016
Control	42GW9017
Control CRC	33DFS-RM
Auxiliary board	42GW9013

\* Not to be used on units equipped with electric heater (mod.42GWE)

# 42 GW

## General Information

---

### Unit installation

Read this instruction manual thoroughly before starting installation.

- **This unit complies with the low-voltage (EEC/73/23) and electromagnetic compatibility (EEC/ 89/336) directives.**
- The installation should be carried out by a qualified installer.
- Follow all current national safety code requirements. In particular ensure that a properly sized and connected ground wire is in place.
- Check that the voltage and frequency of the mains power supply are as required for the unit to be installed; the available power source must be adequate to operate all other appliances connected to the same line. Also ensure that national safety code requirements have been followed for the main supply circuit.
- Where necessary, use field-supplied 25 mm I.D. PVC pipe of appropriate length and with the correct thermal insulation for the condensate drain extension.
- After installation thoroughly test system operation and explain all system functions to the owner.
- Use this unit only for factory approved applications: **the unit cannot be used in laundry or steam pressing premises.**

#### **WARNING:**

**Disconnect the mains power supply switch before servicing the system or handling any internal parts of the unit.**

- The manufacturer declines any liability for damage resulting from modifications or errors in the electrical or water connections. Failure to observe the installation instructions, or use of the unit under conditions other than those indicated in Table "Operating limits" of the unit installation manual, will immediately invalidate the unit warranty.
- Failure to observe electric safety codes may cause a fire hazard in the event of short circuits.
- Inspect equipment for damage during transport. In case of damage file an immediate claim with the shipping company. Do not install or use damaged units.
- In case of malfunction turn the unit off, disconnect the mains power supply and contact a qualified service engineer.
- Maintenance must only be carried out by qualified personnel.
- **All of the manufacturing and packaging materials used for this appliance are biodegradable and recyclable.**
- Dispose of the packaging material in accordance with local requirements.

### Choosing the installation site

#### **Positions to avoid:**

- Exposure to direct sunlight.
- Areas close to heat sources.
- On damp walls or in positions that may be exposed to water hazard.
- Where curtains or furniture may obstruct free air circulation.

#### **Recommendations:**

- Choose an area free from obstructions which may cause uneven air distribution and/or return.
- Consider using an area where installation is easy.
- Choose a position that allows for the clearances required.
- Look for a position in the room which ensures the best possible air distribution.
- Install unit in a position where condensate can easily be piped to an appropriate drain.

# 42 GW

## Avoid...

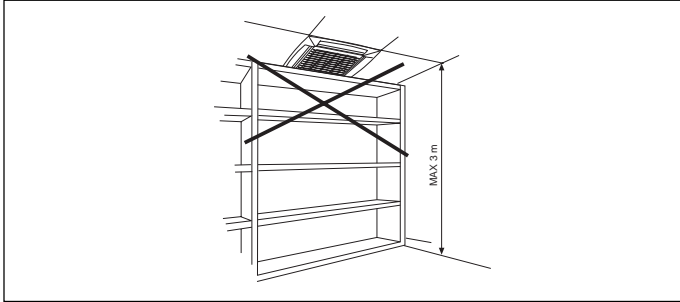

... any obstruction of the unit air intake or supply grilles.

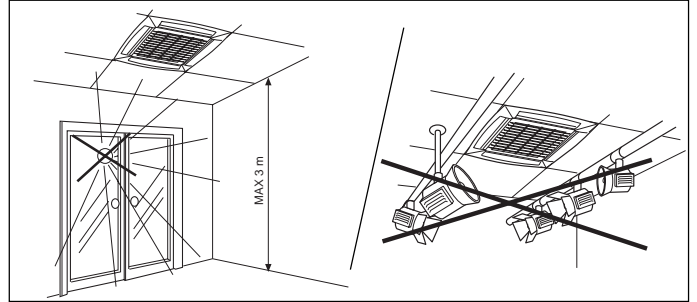

... exposure to direct sunshine, when the unit is operating in the cooling mode; always use shutters or shades.  
... positions too close to heating sources which may damage the unit.

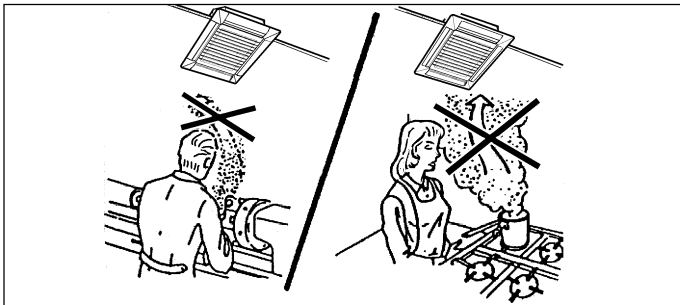

... exposure to oil vapours.

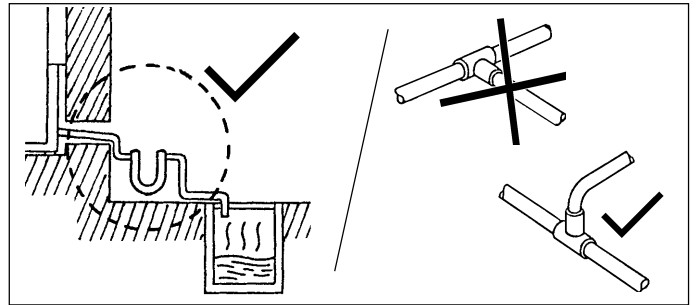

... connecting condensate piping to sewage system drain without appropriate trap. Trap height must be calculated according to the unit discharge head in order to allow sufficient and continuous water evacuation.

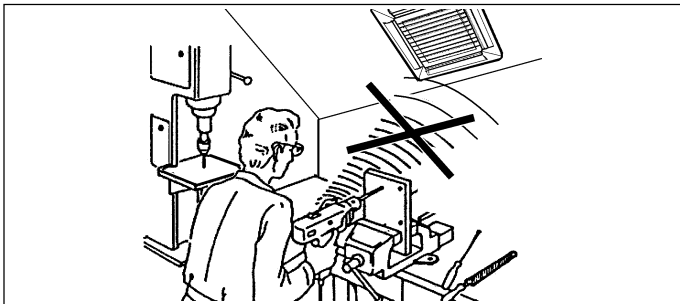

... installation in areas with high frequency waves.

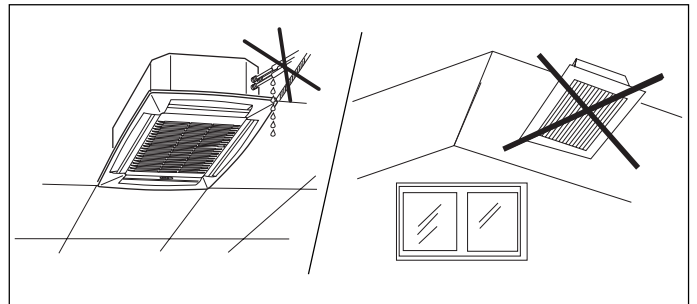

... only partial insulation of the piping.  
Non-level installation which will cause condensate dripping.

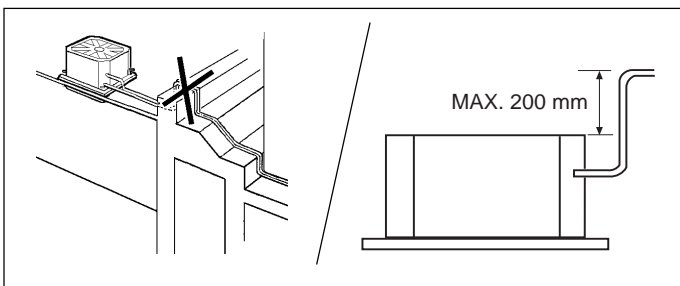

... ascending sections of condensate drain piping.  
These may only be used near the unit with a maximum height difference of 200 mm from the top of the unit.

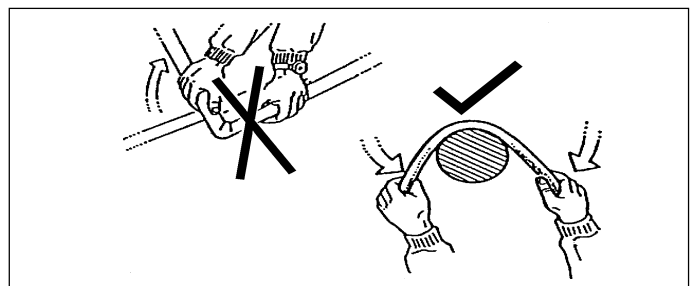

... flattening or kinking the refrigerant pipes or condensate pipes.

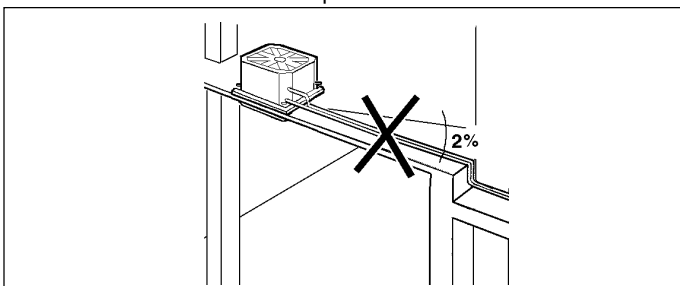

... horizontal sections or curves of condensate drain piping with less than 2% slope.

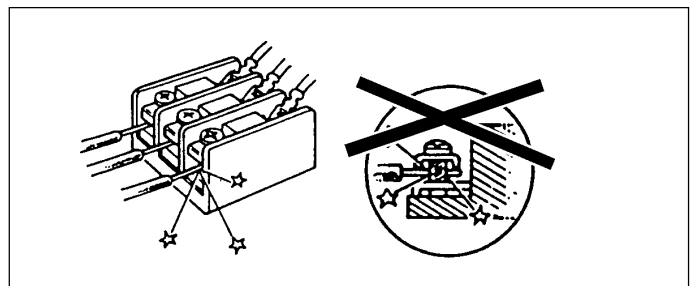

...slack on electrical connections.

# 42 GW

## Installation

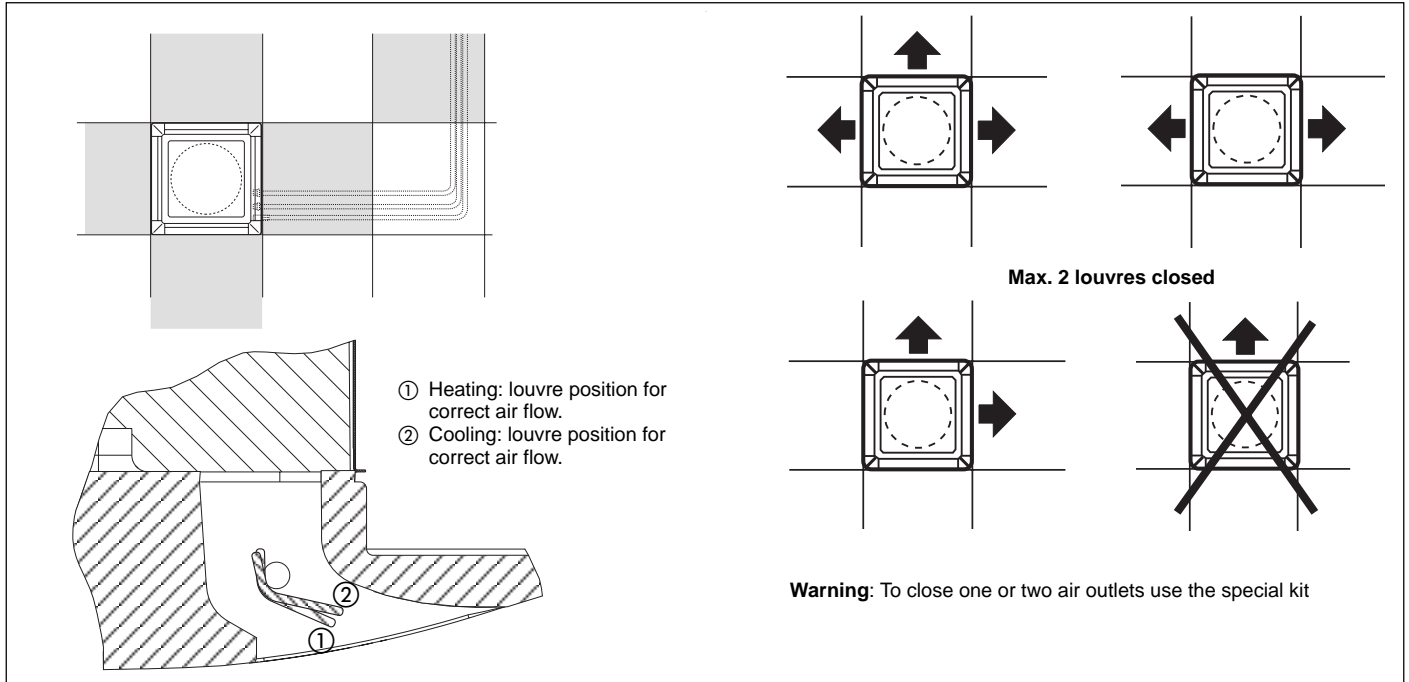

- Install the unit as centrally as possible in the room, the air flow direction can be controlled by manually regulating the louvres position, according to the operating mode (cooling or heating): this will ensure optimum distribution of the air in the room.
- During cooling mode operation the best position for the deflecting louvres is one which allows air diffusion close to the ceiling (Coanda effect). In heating mode, the louvres should be positioned so that the air is directed towards the floor, in order to prevent layers of hot air forming in the upper part of the room.
- In order to allow easy and rapid installation and maintenance, make sure that in the selected position it is possible to remove the ceiling panels or, if the ceiling is constructed of masonry, that access to the unit is guaranteed.

**ATTENTION:**  
 Only restrict the air outlets as indicated in the drawing.

### Prior to installation

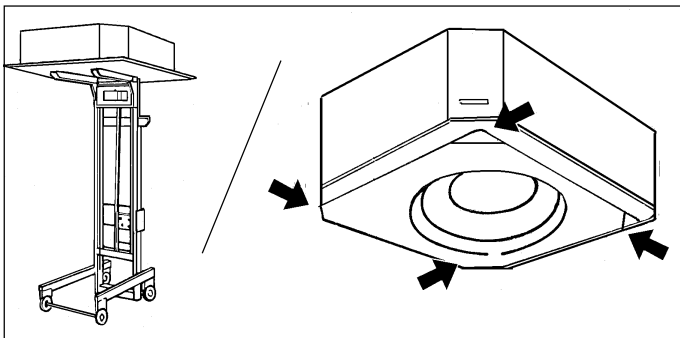

It is advisable to place the unit as close as possible to the installation site before removing it from the packaging. The grille panel and the control are separately packed for maximum protection.

**IMPORTANT:**  
 Do not lift the unit by the condensate drain discharge pipe; hold it by its four corners only.

Unit installation will be facilitated using a stacker.

If plaster board ceiling panels are installed the maximum dimensions of the unit housing must not exceed 660 x 660 mm (mod. 004 - 008 - 010) and 900 x 900 mm (mod. 012 - 016 - 020).

In rooms with high humidity, brackets should be insulated by self adhesive insulation supplied.

### Installation

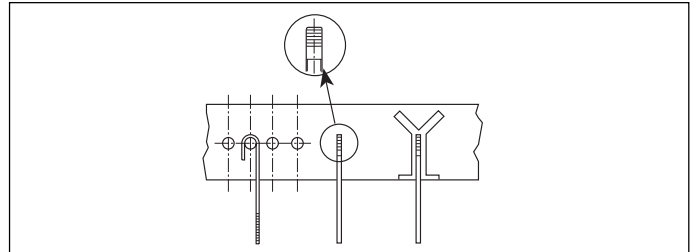

Mark the position of the hangers, connection lines and condensate drain pipe, power supply cables and remote control cable (see dimensions); the cardboard template (supplied with the kit) may be of assistance for this operation. Depending on the type of ceiling the hangers can be fixed as shown in the drawing.

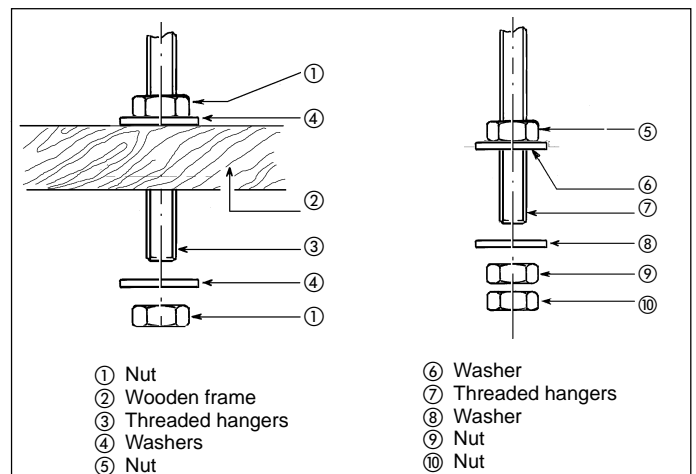

Once the threaded hangers have been positioned, **do not tighten** the nuts, and insert the washers as shown in the drawing.

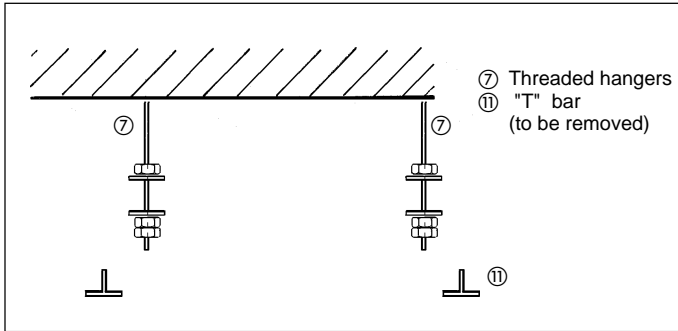

First position the connection lines, as described in the chapter "Water connections".  
Remove the "T" bar in order to facilitate installation operations.

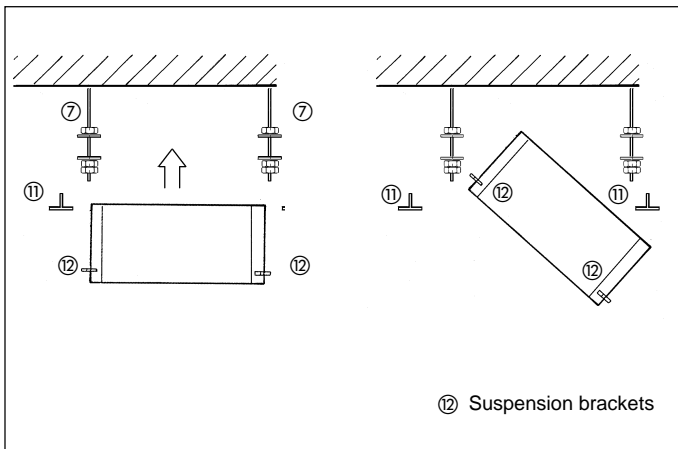

Carefully lift the unit (without the frame) using the four suspension brackets (or the four corners), inserting it into the false ceiling.  
If the "T" bar cannot be removed the unit may need to be tilted (this operation may only be carried out with false ceilings with a minimum height of 300 mm).

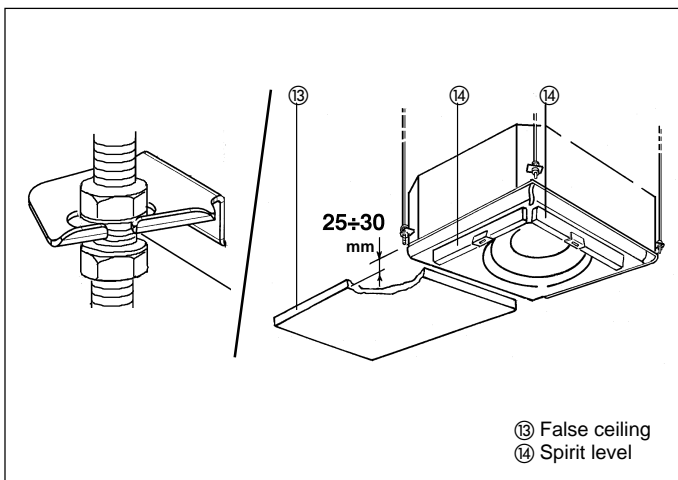

Align and level the unit by adjusting the nuts and locknuts on the threaded hangers, maintaining a distance of 25 -30 mm between the sheet metal body and the underside of the false ceiling.  
Reposition the "T" bar and align the unit in relation to the bar by tightening the nuts and locknuts.  
After connection of the condensate drain line and the refrigerant lines, carry out a final check to make sure that the unit is level.

### Condensate drain pipe

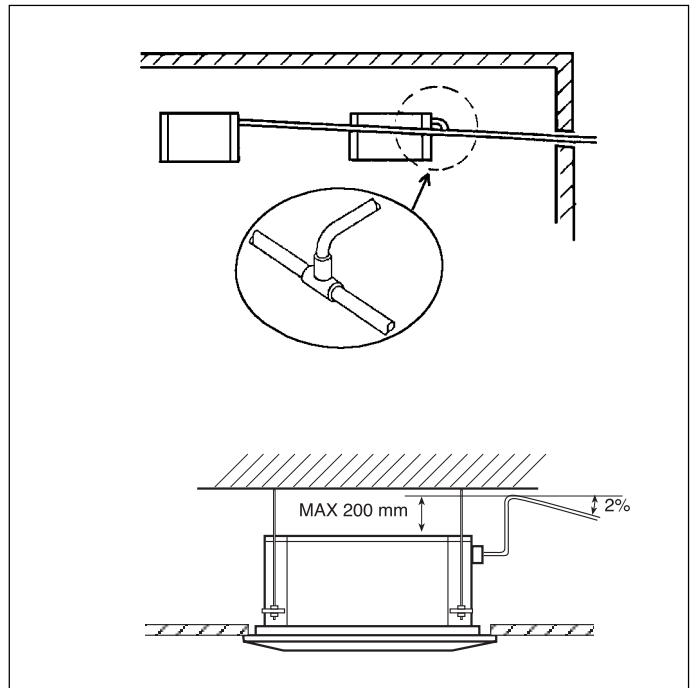
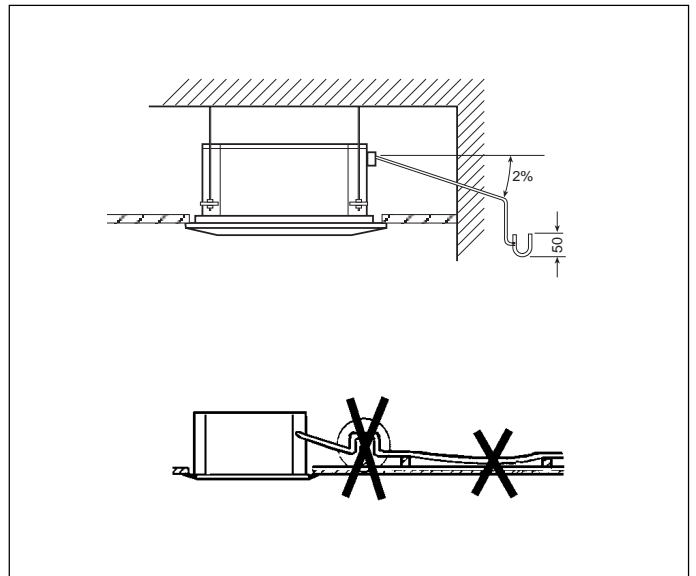

- To ensure correct condensate water flow, the drain pipe should have a gradient of 2% without obstructions. Furthermore an odour trap of at least 50 mm depth should be made to prevent unpleasant odours from reaching the room.
- Condensate may be discharged at a maximum height of 200 mm above the unit, as long as the ascending tube is vertical and aligned with the drainage flange.
- If it is necessary to discharge the condensate from a level above 200 mm, install an auxiliary water discharge pump and float valve.  
A float valve is recommended to stop the flow switch if there is a fault at the auxiliary pump.
- The condensate pipe must be insulated with a condensation-proof material such as polyurethane, propylene or neoprene of 5 to 10 mm thickness.
- If more than one unit is installed in the room, the drain system can be made as shown in the drawing.



# 42 GW

## Installation

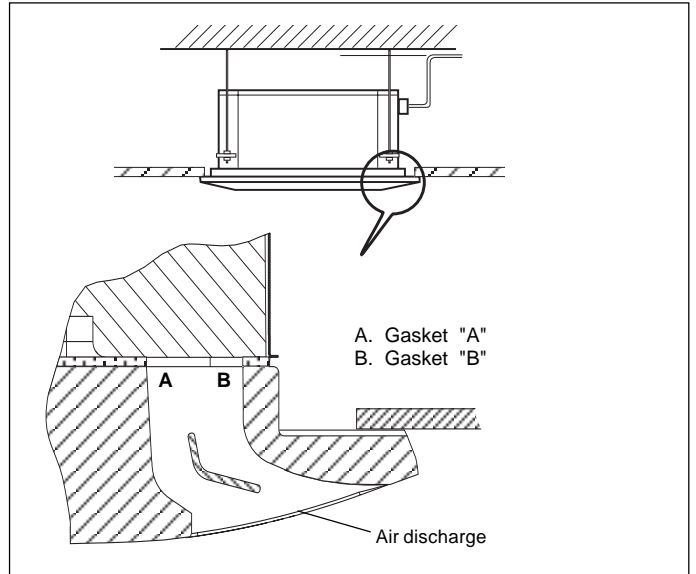
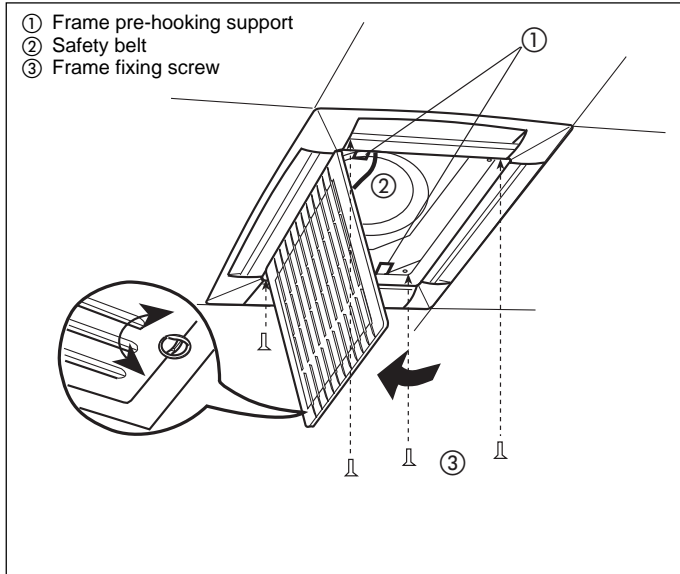

### Installation of grille/frame assembly

Carefully unpack the assembly and check for damage sustained in transit. Attach the assembly to the unit by using the two hooks.

Use the screws supplied to fix the frame in position.

Ensure that the frame is not distorted by excessive tightening, that it is aligned with the false ceiling and above all that there is a seal between the air inlet and outlet.

In the drawing gasket "A" prevents return air from mixing with the supply air and gasket "B" prevents the supply air from leaking into the ceiling void.

On completion, the gap between the unit frame and the false ceiling must not be more than 5 mm.

## Water connections

Water connections are fixed to the unit body to avoid damage when pipes are connected; it is advisable to tighten the connection with a spanner.

The upper coil connection is supplied with an air purge valve, the lower connection with a water purge valve, suitable for a 10 mm wrench or screw-driver.

**(The coil is only partially drainable; it is advisable to blow air into the coil for complete drainage).**

Models	Connections dimension (Ø)	Models	Connections dimension (Ø)
004	3/4"	012	1"
008	3/4"	016	1"
010	3/4"	020	1"
004*	1/2"	020*	3/4"
010 *	1/2"		

\* Hot water circuits, four-pipe version

## Checking

Before unit operation pour a quantity of water into the external auxiliary drain pan. Verify that the water flows into the internal condensate drain pan and that the pump regularly drains the liquid.

Otherwise check the pipe slope and look for possible obstructions. Water connections are fixed to the unit body to avoid damage when pipes are connected; it is advisable to tighten the connection with a spanner.

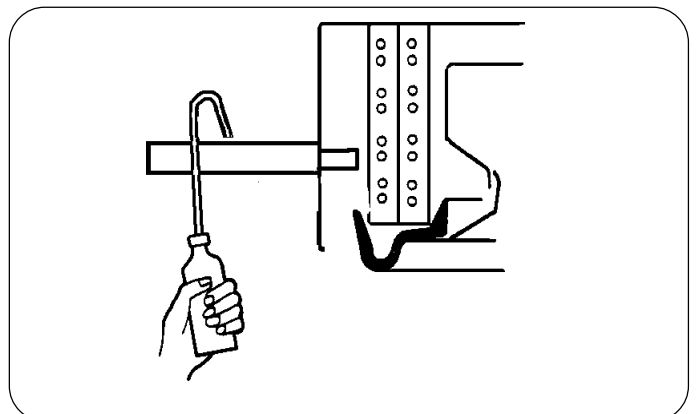
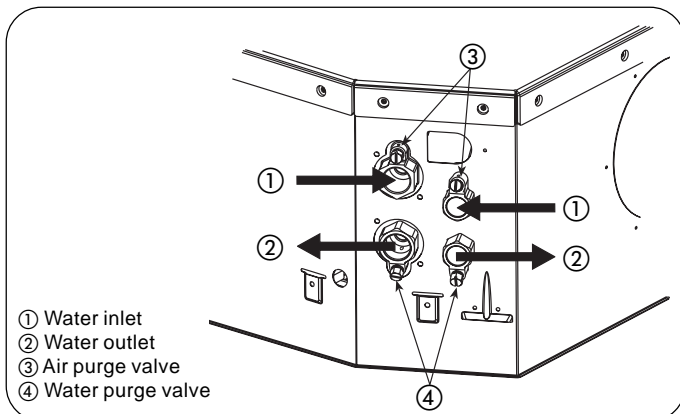

- The unit control circuit only allows opening of the motorized valve when the fan motor is working. (See wiring diagrams)
- When the thermostat asks for cooling, terminal 1 of TB3 (cold water) is supplied with 230V. When it asks for heating, terminal 2 of TB3 (hot water or electric heater) is supplied with 230V.
- The control circuit ensures that the condensate discharge pump works continuously while the thermostat, asking for cooling, keeps the cold water regulating valve open.

**WARNING :**

The valve is not only necessary to control the room temperature, but also to stop the cold water flow to the coil in case of an abnormal condensing water level rise in the drain pan.

- If there is an abnormal condensing water rise in the drain pan (for example: possible defective drain, pump malfunction, fan motor not working) causing the opening of the float switch contact (FS), the control circuit either operates the condensate drain pump, or at the same time closes the regulating valve, stopping the cold water flow towards the coil and avoiding further condensation.

**Control**

The water flow has to be controlled:

- by installing the motorized thermo-electric valves supplied as accessory
- or
- by installing motorized field supplied valves.

**Motorized thermo-electric valve assembly and components**

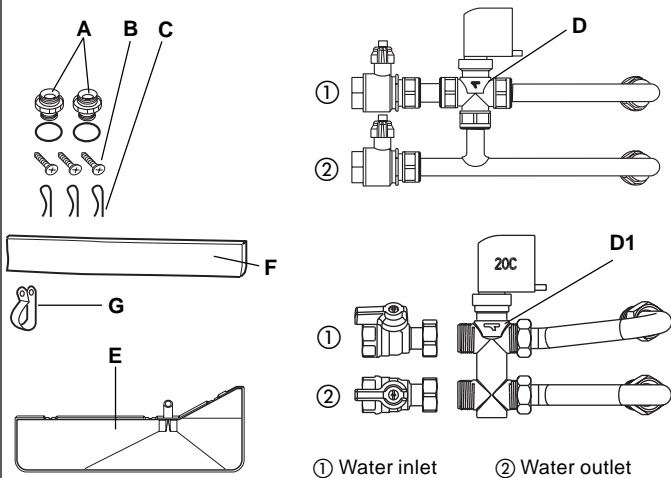

Mod. 42GW	004 012		004 020	
	008 016		010 020	
	2-pipe		4-pipe	
Ref. Description	q.ty	q.ty	q.ty	q.ty
A Adaptor 3/4" gas with O-ring		2		
Adaptor 1" gas with O-ring + Adaptor 3/4" gas with O-ring +				2+
B Self tapping screw	3	3	3	3
C Clip	3	3	3	3
D Valve 1" gas pre-assembled		1		
Valve 1" gas pre-assembled + Valve 3/4" gas pre-assembled				1+
D1 Valve 3/4" gas pre-assembled	1			
Valve 3/4" gas pre-assembled			1+	
Valve 1/2" gas pre-assembled			1	
E Auxiliary drain pan	1	1	1	1
F Insulating material	1	1	1	1
G Cable holder	1	1	1	1

**Instructions for mounting of motorized thermo-electric valve assembly**

(see "Components" table)

- The thermo-electric valve must be mounted on the unit after the unit installation. For this operation follow figures, depending on model.
- Insert the clips supplied in the unit side slots.

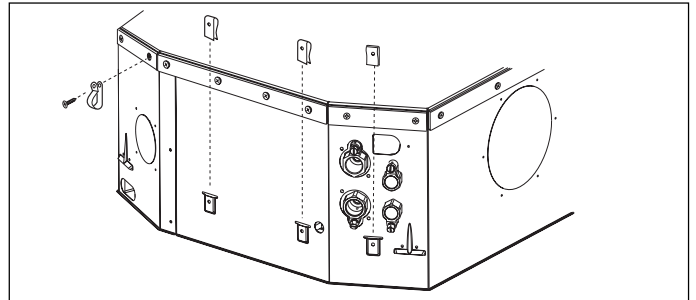

**Assembly**

For models 42GWD (4-pipe), the valve assembly for the cold water coil must be installed first.

- Gently grease the O-rings before fitting them into their seats.

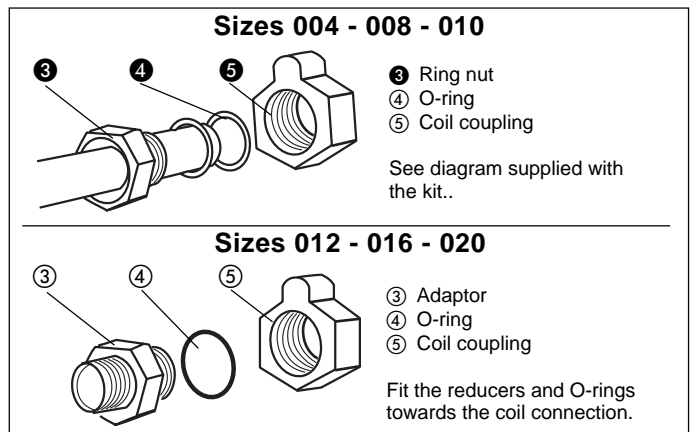

- Connect the valve assembly to the coil and fix it by a 30Nm torque.
- Insulate the valve assembly.
- For 4-pipe hot water coil, repeat all the operations with gas adaptors, as per the table.
- Pass cables through the cable holder G and fix them to the case using the already pre-assembled screws.
- Mount the drain pan below the valve assembly, inserting the discharge pipe into the special hole; align and fix it to the 3 clips previously assembled using the three screws supplied.
- Insulate the 3 screws and the drain pan lower part using the insulating material F.
- To connect the steel pipes to the system, ensure they are aligned and supported to avoid excess strain on the unit. If the system is filled with water, check all fitting seals.

**NOTE:**

The seal efficiency of the valve assembly is factory tested. Any system losses are therefore due to an incorrect installation.

**Electric connections**

- To connect valves to the electric panel pass cables through the electric panel grommet and connect them to the terminal board TB3 as per the wiring diagrams.

# 42 GW

## Motorized valve and control

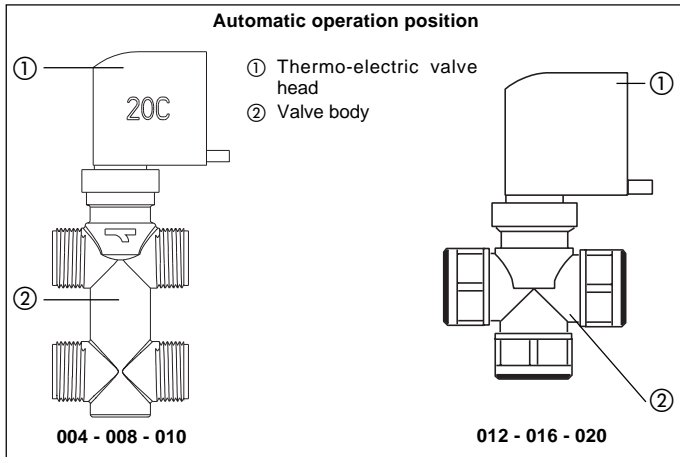

### Operation of the thermo-electric valve

- This 3-way valve is an ON-OFF type with a very slow stroke. It is not a modulating valve so it has no PTC. This valve is driven, as a sensible element, by the ambient thermostat of the "cassette" unit.
- The thermo-electric valve is normally closed towards the coil and open towards the bypass. When the room temperature does not satisfy the thermostat, an electric heater activates the heating of a thermostatic element which causes the down-stroke of the piston; the valve opens after about 3 minutes about to allow water to circulate in the coil.
- If the room temperature satisfies the thermostat or if the electric power has been switched off, the valve is closed after about 3 minutes towards the coil and is opened towards the bypass.
- If an emergency occurs, the valve may be manually opened, removing the electric head, unscrewing the ring nut.

**When the emergency ends, remember to reset the valve to automatic operation, repositioning the electric head; failure to do this can result in condensate formation due the water pipes, even if the unit is switched off.**

## Instructions for field supplied valves

### Water connection

- Install valves following manufacturer's instructions; refer to the relevant figures for connection to the unit.
- Carefully insulate pipes, valve assemblies and coil connections (cold water side) to avoid condensation forming on the pipes and dripping on the false ceiling.

### Electrical wiring

- Connect the room control following instructions for the control used.

#### WARNING:

**Pass cables through the control panel cable-conduit.**

- Connect valves as per the following instructions, using the wiring diagram in this chapter.
- **Valves, closing the unit water inlet when there is no power supply, must be used.**

### ON-OFF valves (230V)

- In this case the cold water valve must be controlled by the ON-OFF signal from terminal 1 of TB3 and the hot water valve from terminal 2 of TB3.

### ON-OFF valves with other voltages than 230V

- If a room control listed in the accessories table is used, follow the instructions in the previous paragraph and install two 230V relay at TB3 terminals 1, 2, 4 and 5 which will control the valve opening.

### 230V valve connection or 230V valve relay connection

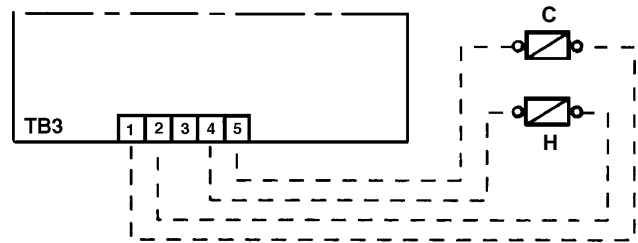

H Heating valve or heating valve relay  
C Cooling valve or cooling valve relay

- If a low voltage control is used or if the control is not listed in the accessories table, the connections must be made on the unit terminal board.

### Control connection

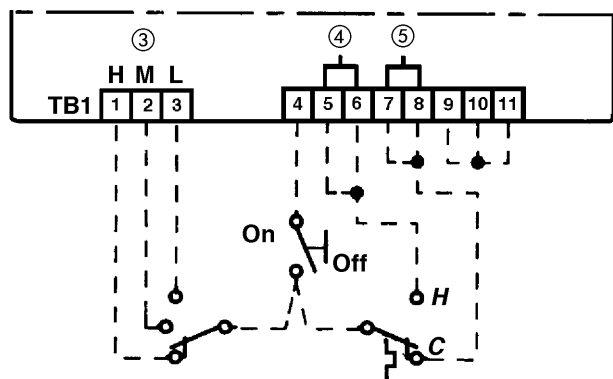

③ Fan speed  
H = high speed  
M = medium speed  
L = low speed  
④ Heat  
⑤ Cool

- If these connections are not made as described the drain pan condensate may overflow.
- Valves should only open when the fan motor is working, i.e. when one of TB1 terminals 1 or 2 or 3 is supplied from TB1 terminal 4.
- The optional electric heater (mod. 42GWE) which can only be factory installed, must only be energized when the fan is working.
- The optional electric heater which must be factory installed on model 42GWE, works only if TB1 terminals 5-6 are supplied from TB1 terminal 4.
- The water discharge pump should work every time the cold water valve is opened, supplying TB1 terminal 7 and 8 from TB1 terminal 4.
- When the system is filled with water, verify all couplings for tightness.
- The manufacturer does not accept responsibility for the tightness of the field - installed valve assembly and this is not tested in the factory. He declines any responsibility for non functioning of these assemblies and for damage due to dripping.

## Electrical connections

We recommend to remove the main board from the electric panelboard for better access to electric connections.

### STANDARD version unit - Control panel

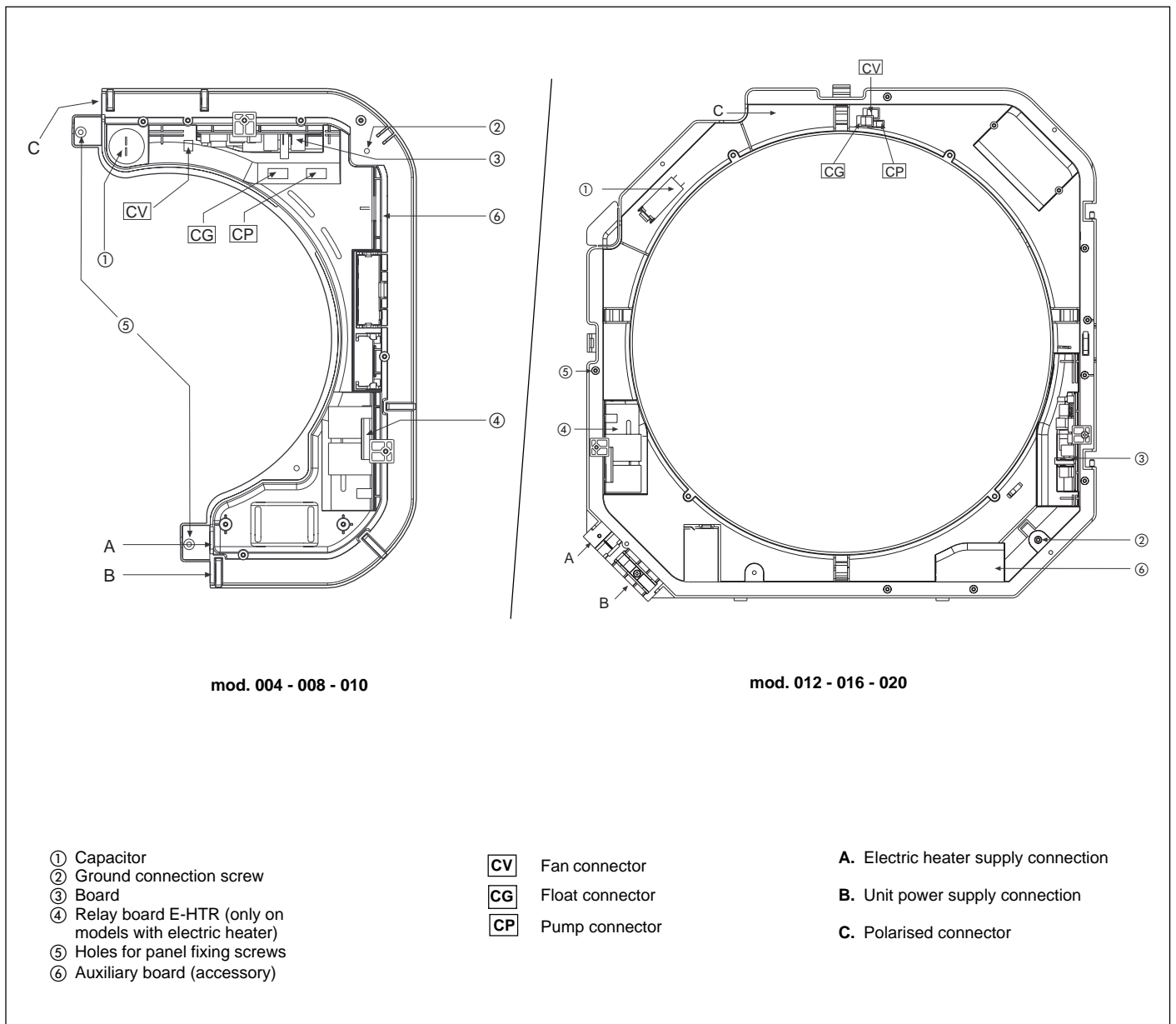

# 42 GW

## Electrical connections

The control panel can be reached by opening the grille and removing the metal covers using the 3 or 4 screws.

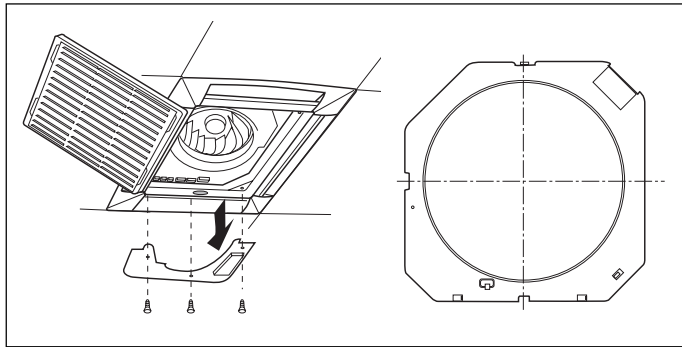

### IMPORTANT for units with electric heaters;

The unit is equipped with two thermostats: one with automatic reset and one with manual (electric) reset that can be reactivated by switching the power supply off and then on.

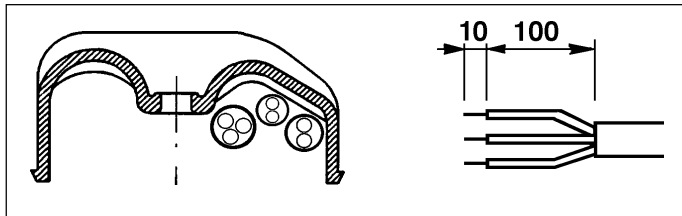

Connect the power cables to terminal box connectors in accordance with the wiring diagram and tighten firmly.

### IMPORTANT:

• Make ground connection prior to any other electrical connections.

- If the unit is fitted with an electric heater, this must have a separate power supply. Ensure that the mains supply connection is made through a switch that disconnects all poles, with a contact gap of at least 3 mm.
- Fix the power cable of the electric resistance heaters under the single cable clamp. Make certain that the YELLOW/GREEN cable is stripped back further than the others.

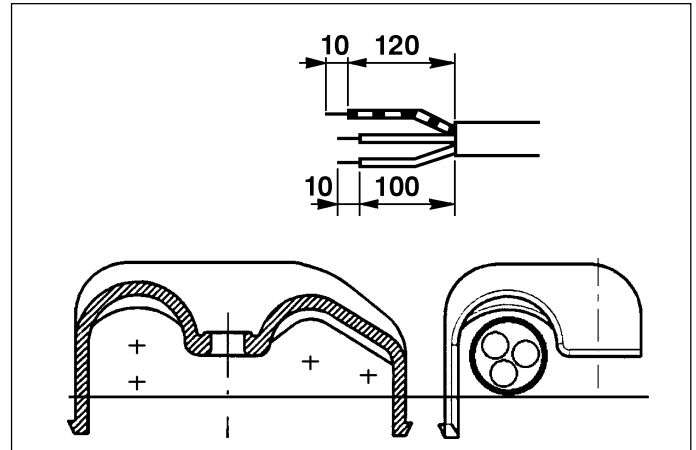

## Wiring diagram legend

- Factory wiring
- - Field wiring
- ⊕ Connector
- Terminal on terminals
- ⊕ Normally closed contact
- ⊖ Normally open contact
- ⊕ Capacitor
- FC Fan capacitor
- FS Safety switch float
- IFM Fan motor indoor unit
- PR Drain pump relay
- PS Drain pump
- C1-3 Connectors
- HR Heating relay
- CR Cooling relay
- CEV Electric valve (cooling)
- HEV Electric valve (heating)
- PCB Relay board
- HTR Electric heater
- ST Safety thermostat
- T Timer
- TB Terminal board

- ① Low speed
- ② Medium speed
- ③ High speed
- ④ Power supply line
- ⑤ Heating selection
- ⑥ Common thermostat (heating)
- ⑦ Cooling selection
- ⑧ Common thermostat (cooling)
- ⑨ Neutral fan
- ⑩ Neutral in
- ⑪ Neutral out
- ⑫ Neutral
- ⑬ Heating out
- ⑭ Cooling out

### Cables colour

- A Brown
- B Blue
- C Black
- G Grey
- R Red
- W White
- Y-G Yellow/Green

### Connections

- L Line phase
- N Neutral

### Warning:

Any warranty is declined in case of field changes of factory wiring and settings

### Note

The connection sequence does not represent the physical lay-out.

# 42 GW

## Wiring diagram, standard version unit

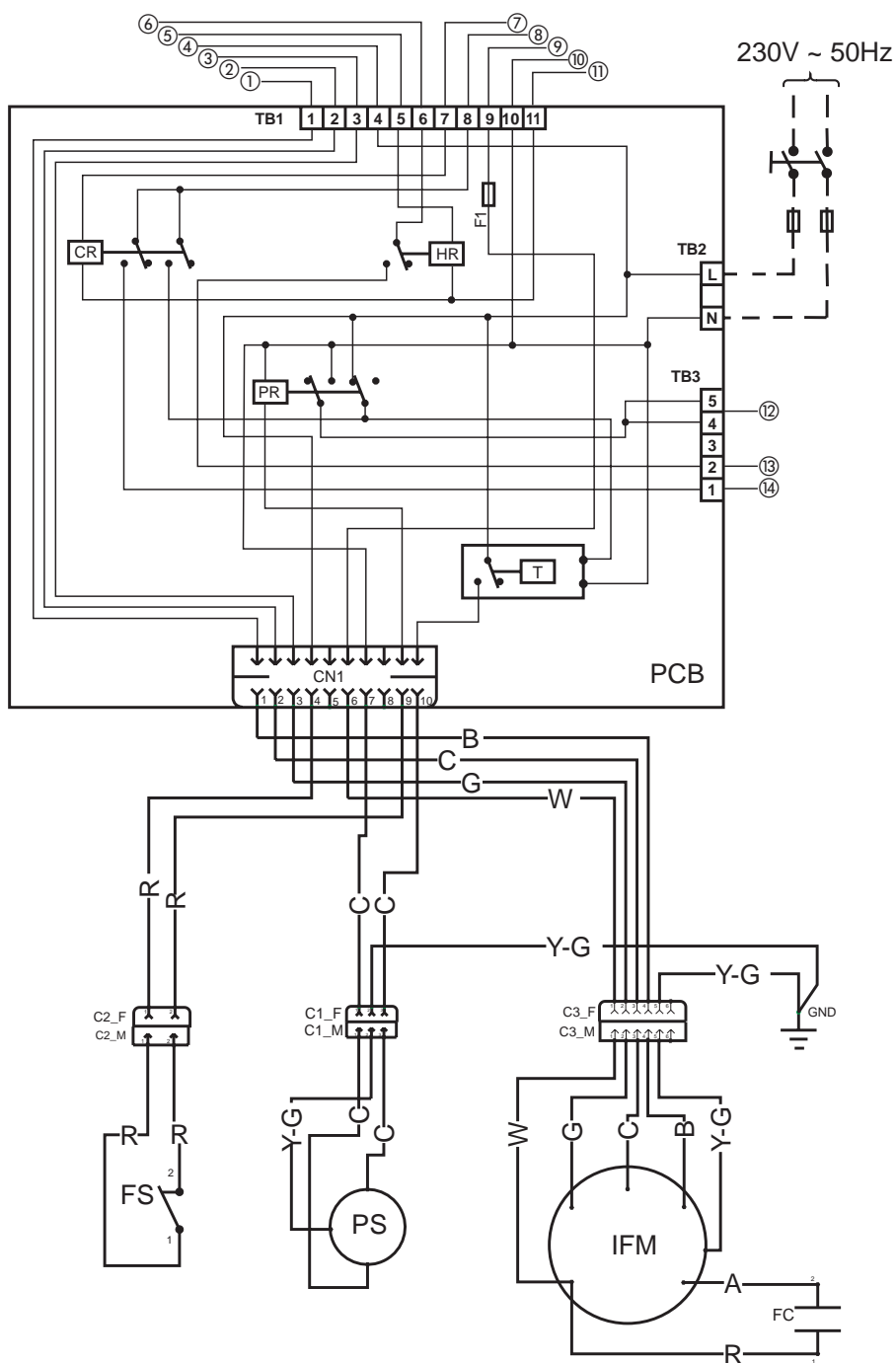

**Valves connection:**  
select the diagram according to the system type

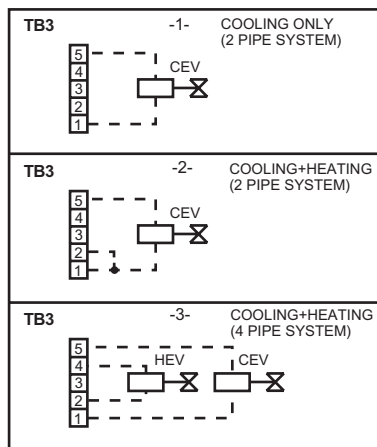

### Electric heater supply

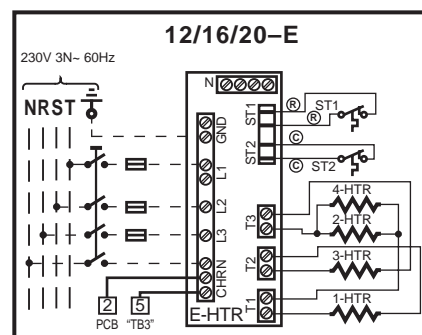
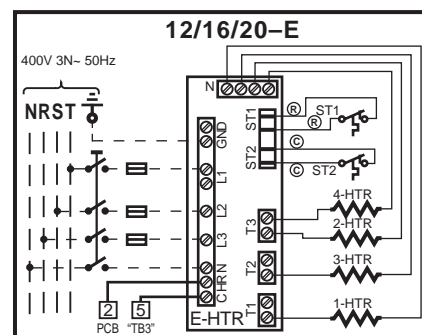
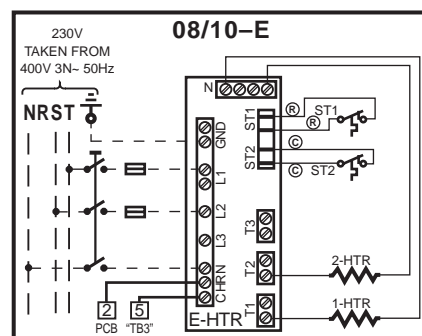
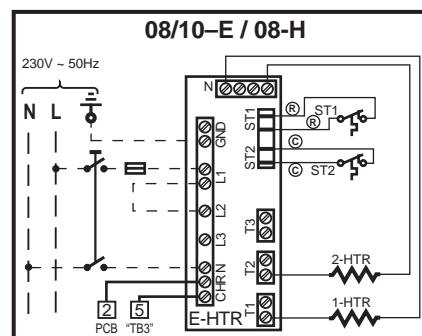
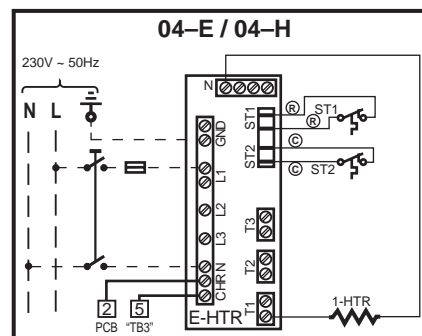

# 42 GW

## Fresh air renewal and conditioned air supply to an adjacent room

Model		004-008-010	012-016-020
Ø A	mm	150	150
B	mm	120	120
Ø C	mm	70	100

- ① Duct connection flange
- ② Clip
- ③ 6 mm neoprene gasket
- ④ Insulated flexible duct
- ⑤ Fresh air intake
- ⑥ Conditioned air supply to an adjacent room
- ⑦ Polystyrene partition
- ⑧ Baffle
- ⑨ Frame

### Air intake grille

- ⑩ Wall
- ⑪ Undercut door
- ⑫ Wall-fitted grille
- ⑬ Door-fitted grille

- Side knockouts allow connection of fresh air inlet ducts and ducts to deliver conditioned air to an adjacent room.
- Remove the external prepunched anti-condensate insulation and take away the knockout panels using a punch.

### Air distribution to adjacent room

With a pencil, trace a line on the polystyrene around the inside edges of the panel that was previously removed. Cut away the polystyrene with a knife, taking care not to damage the heat exchange coil.

### Fresh air intake

Remove the polystyrene partition. Introduce the baffle supplied after the frame has been hooked as per above figure (ref. ⑧).

Following that tighten the assembly frame/grille using the 4 screws.

- Use locally purchased material, suitable for operating temperatures of 60 °C (continuous). Conduits can be of flexible polyester (with spiral core) or corrugated aluminium, externally covered with anti-condensate material (fibre glass of 12 +/- 25 mm thickness).
- To complete the installation, all non-insulated ducts must be covered with anti-condensate insulation (ex. expanded neoprene, 6 mm thickness).

**If these instructions are not observed, condensate may drip; the manufacturer will not be held responsible for any damage caused.**

- The two prepunched side knockouts must not be used at the same time to deliver conditioned air to an adjacent room.
- The return and supply duct lengths can be calculated in accordance with the "air distribution to an adjacent room" and "fresh air renewal" diagrams (also taking into account the pressure drop through air diffusers, grilles and fresh air filters), as well as the increase in noise caused by these ducts.

### Fresh air renewal

- The optional supplementary fan for fresh air intake (field supplied) has to be connected to terminal block as per diagrams enclosed.  
Fan motor operation is parallel to the thermo-electric control valve, and the motor stops when the valve shuts off.
- For winter operation with fresh air intake, an anti-freeze thermostat set at 2°C is recommended, with the bulb placed on the water outlet pipe, before the supplementary fan.
- The fresh air flow must be less than 10% of the total air flow, to avoid operating problems or excessive noise.  
For higher air flow a "primary air kit" is available which uses the prepunched hole for air ducting to an adjacent room and a baffle so that the fresh air is introduced into the room through a diffuser.
- Install an air inlet grille with filter inspection port to prevent dust and dirt from entering and fouling the unit heat exchanger.  
Filter installation also makes the installation of a duct closing damper during shut-down periods unnecessary.

### Conditioned air supply to an adjacent room

- **Air supply to an adjacent room requires that the outlet corresponding with the duct is closed, using the air supply outlet obstruction kit supplied. The kit cannot be used in units equipped with electric heater (mod. 42GWE).**  
  
An air inlet grille must be fitted (if possible near the floor) between the air conditioned room (where the unit is situated) and the adjacent room or, alternatively, the door must be undercut, as shown in the drawing.
- The duct lengths can be calculated in accordance with the "air distribution to an adjacent room" diagram, also taking into account the pressure drop through air diffusers and fresh air filters.
- **DO NOT use active carbon or electrostatic filter kits for ducts towards adjacent rooms.**

### Winter operation diagram with fresh air intake

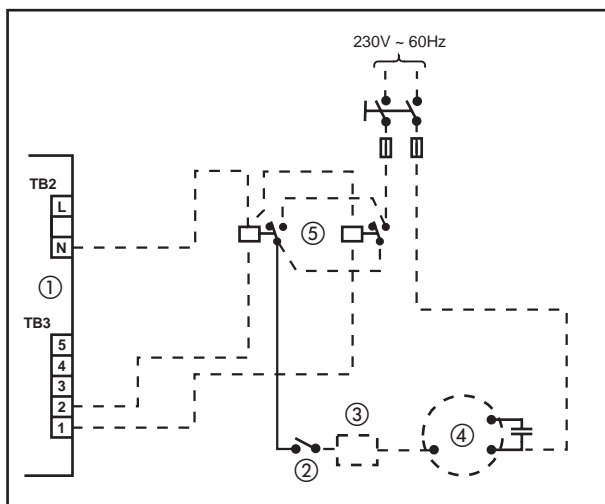

- ① Terminal board
- ② Antifreeze thermostat
- ③ Speed controller
- ④ Fresh air fan motor
- ⑤ Relay 230V

### Diagram of conditioned air supply to an adjacent room: one louvre closed

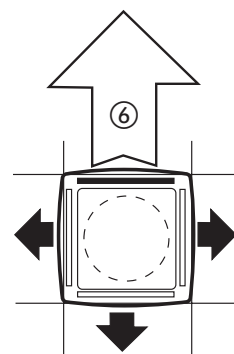
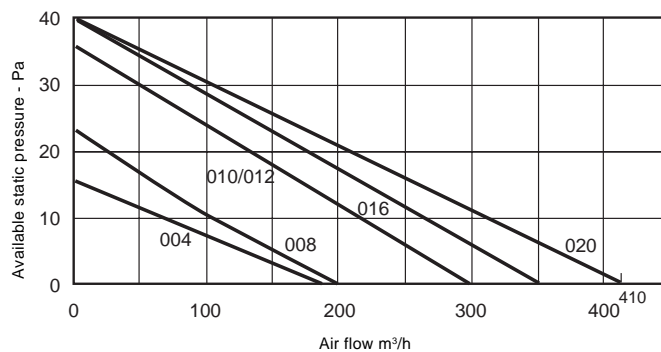

⑥ Supply air duct to adjacent room

In case of two louvres closed, the fresh air flow towards the adjacent room is 50% higher compared with only one louvre closed (with equal static external pressure)



# 42 GW

## Maintenance and owner's guide

### Maintenance

Cleaning and maintenance operations must be carried out by specially trained personnel.

Before performing any service or maintenance operations, turn OFF the main power switch.

To open the unit grille:

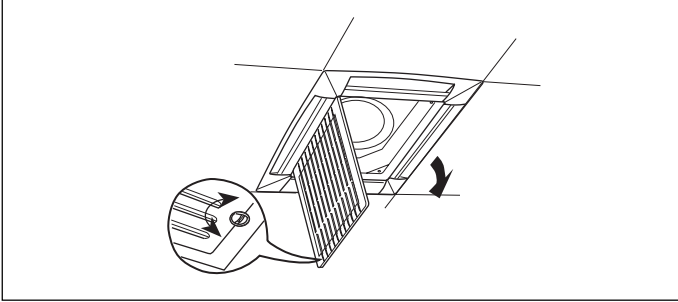

Turn the two screws through 90° (1/4 turn).

### Filter cleaning

Clean filters in accordance with the actual operating conditions and times (approximately every 6 months).

- The acrylic air filter is washable in water.

Electrostatic and active carbon filters (which can be used on the unit) are not washable but must be replaced.

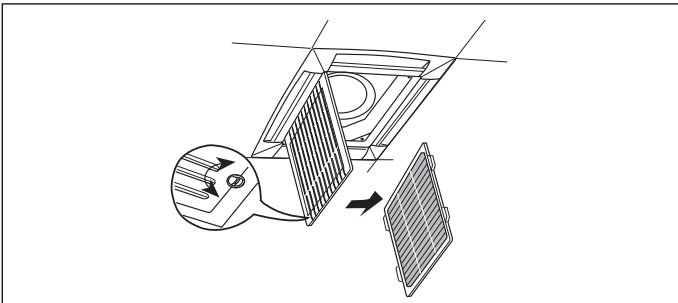

Extract the filter.

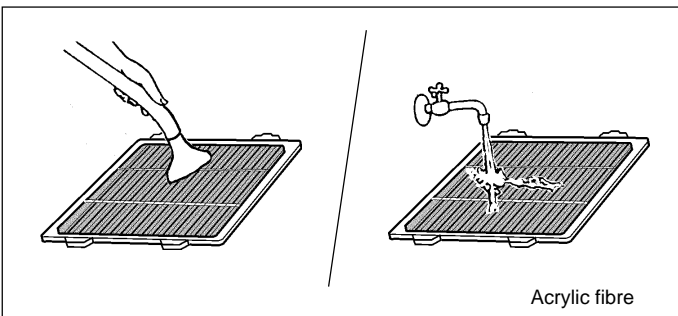

First vacuum clean the filter, then wash under tap water and finally dry.  
Replace the filter in the correct position.

### Prolonged shutdown:

- Before starting the air conditioner:
  - clean or replace the unit air filters.
  - check and clean the drain pan and the condensate discharge of the unit
  - check tightness of electric connections.

### Additional maintenance

- The electric panel is easily accessible by removing the cover panel.  
The inspection or replacement of internal components such as: fan motor, coil, condensate discharge pump, float switch, electric heater (if fitted), involve the removal of the condensate drain pan.

### Condensate drain pan removal

- During the removal operation of the condensate drain pan protect the floor with a plastic sheet under the unit.
- Remove the frame-grille assembly by loosening the screws; drain the condensate water contained in the drain pan into a bucket of at least 10 litres capacity, using the special drain with a rubber plug.
- Remove the electrical panel cover and disconnect the electric connections, connectors Cv, Cg, Cp and the yellow-green ground wire Ⓣ (see drawing in "electrical connections" section).

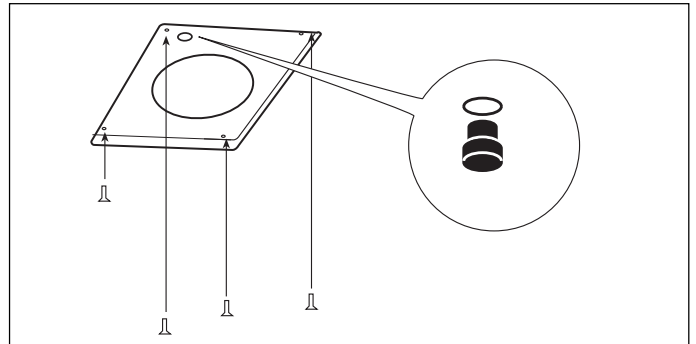

- Remove the four fixing screws on the side of the drain pan and carefully remove the condensate drain pan.

### Guide for the owner

When installation and tests are completed instruct the Owner on the main operating modes of the air conditioner, such as:

- Turning the unit ON and OFF.
- Changing the operation modes.
- Temperature selection.

Leave the installation manual with the owner for future use during maintenance operations or for any other needs.



**Via R. Sanzio, 9 - 20058 Villasanta (MI) Italy - Tel. 039/3636.1**

---

The manufacturer reserves the right to change any product specifications without notice.

## Free Manuals Download Website

<http://myh66.com>

<http://usermanuals.us>

<http://www.somanuals.com>

<http://www.4manuals.cc>

<http://www.manual-lib.com>

<http://www.404manual.com>

<http://www.luxmanual.com>

<http://aubethermostatmanual.com>

Golf course search by state

<http://golfingnear.com>

Email search by domain

<http://emailbydomain.com>

Auto manuals search

<http://auto.somanuals.com>

TV manuals search

<http://tv.somanuals.com>