

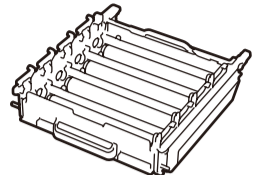

Unpack the machine and check the components

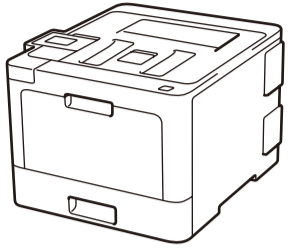

Drum Unit*

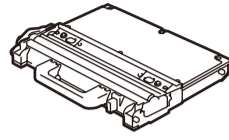

Waste Toner Box*

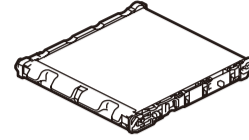

Belt Unit*

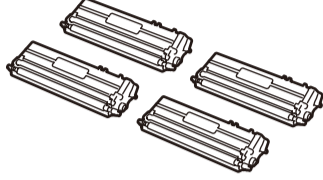

In-box Toner Cartridges*
(Black, Cyan, Magenta and Yellow)



Brother Installation Disc



AC Power Cord



Quick Setup Guide



Product Safety Guide

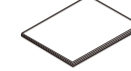

Reference Guide
(only for certain models)

NOTE:

- The components included in the box may differ depending on your country.
- The available connection interfaces vary depending on the model.
- Interface cables are not included. If you require one, it will need to be purchased. Use one of the following cables:

USB cable

We recommend using a USB 2.0 cable (Type A/B) that is no more than 2 metres long.

Network cable

Use a straight-through Category 5e (or greater) twisted-pair cable.

• The illustrations in this Quick Setup Guide show the HL-L8360CDW.



Watch our Video FAQs for help with setting up your Brother machine: solutions.brother.com/videos.

1 Remove the packing materials and install the drum unit and toner cartridge assembly

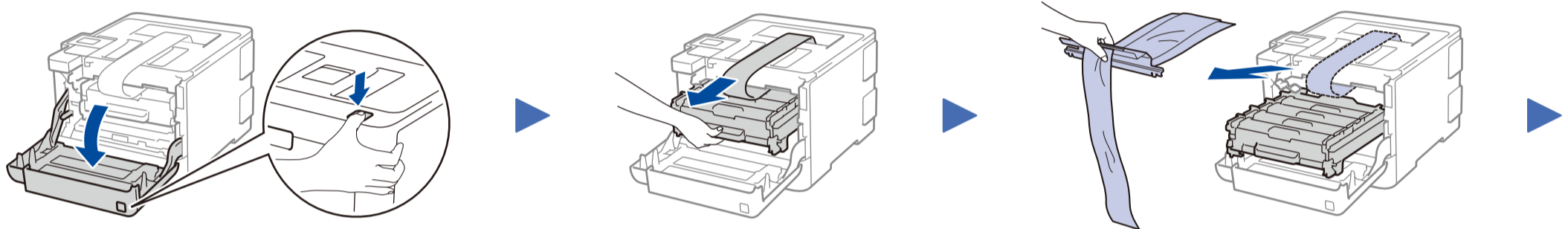

Remove the packing tape.

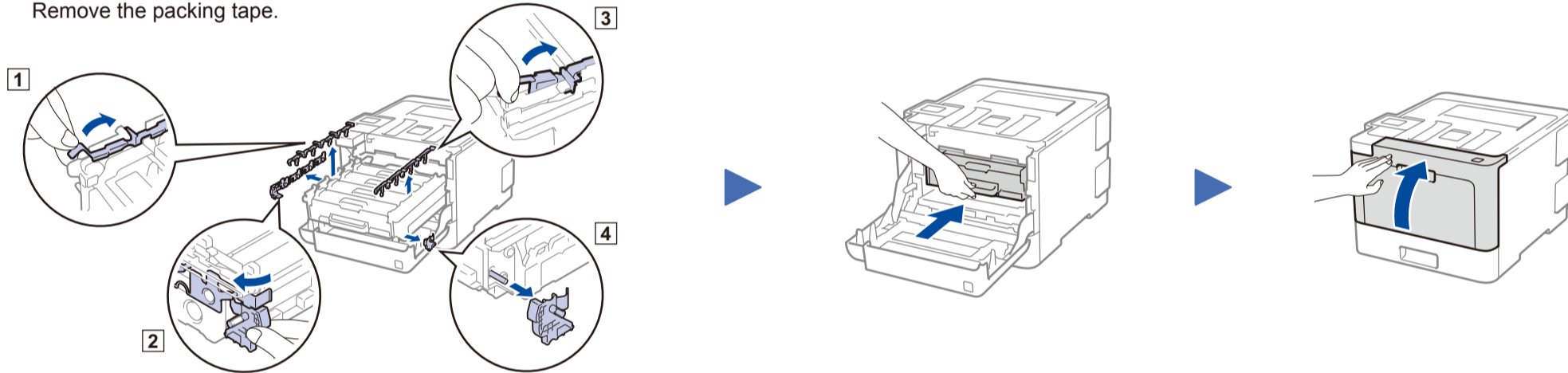

2 Load paper in the paper tray

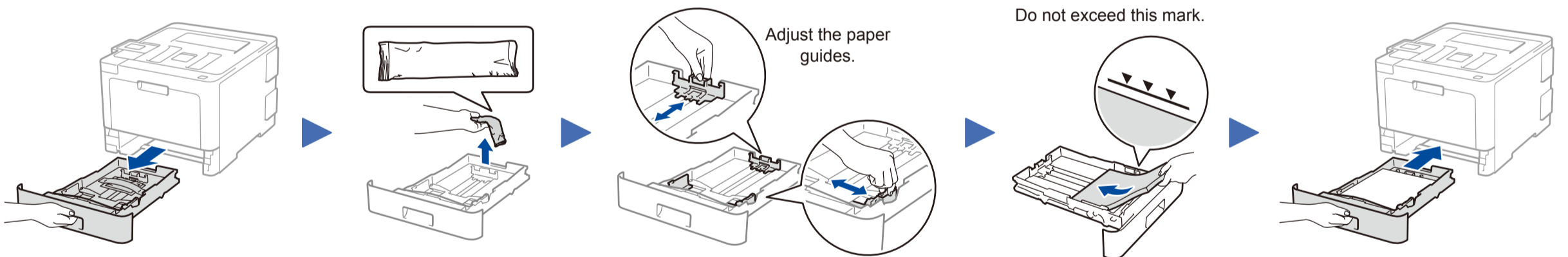

3 Connect the power cord and turn the machine on

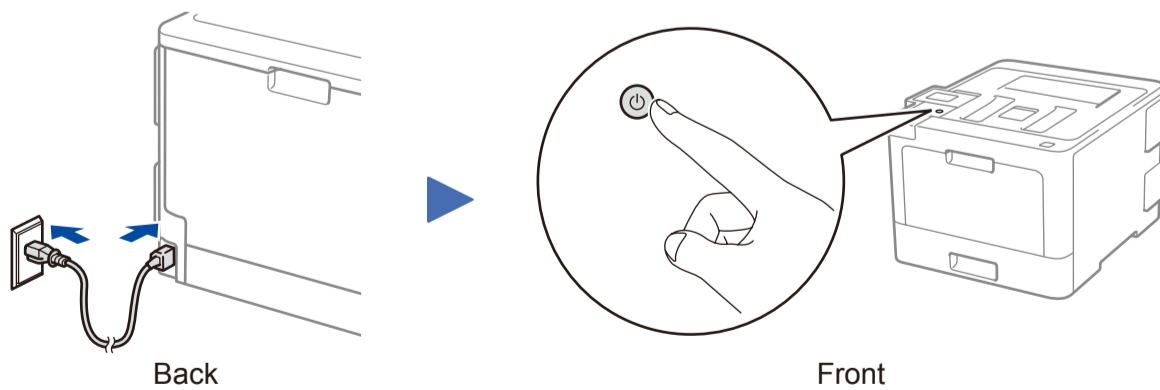

4 Select your language (if needed)

■ For LCD models

1. Press ▼ or ▲ to select [Initial Setup], and then press OK.
2. Press OK to select [Local Language].
3. Press ▼ or ▲ to select your language, and then press OK.
4. Press Cancel.

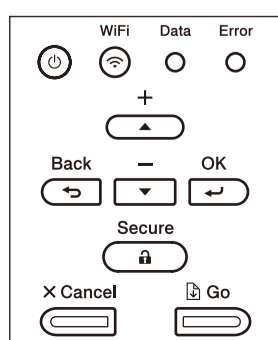

■ For Touchscreen models

1. On the machine's Touchscreen, press [Settings] > [All Settings] > [Initial Setup] > [Local Language].
2. Press your language.
3. Press [Go].

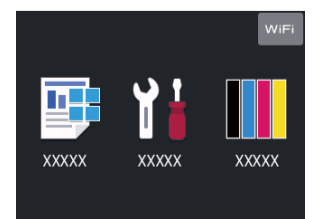

5 Select a device to connect to your machine

Computer



Go to **6** and follow the instructions.

NOTE:
(For HL-L8260CDW)
We recommend configuring wireless settings from your computer.

Mobile Device

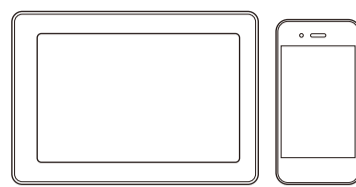

Go to **7** and follow the instructions.

6 Connect your computer

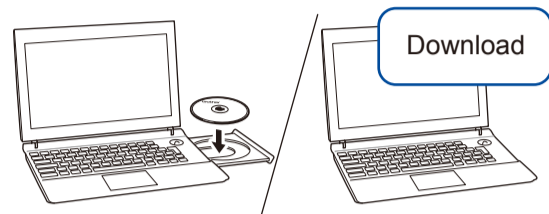

Put the installation disc into your CD/DVD drive, or download the Full Driver & Software Package at:

For Windows®: solutions.brother.com/windows
For Macintosh: solutions.brother.com/mac

If you are using a recently released operating system on your computer, visit the above websites for updated driver and software information.

▶ Follow the on-screen instructions and prompts.

For Windows®:
If the Brother screen does not appear automatically, go to **Computer (This PC)**. Double-click the CD/DVD-ROM icon, and then double-click **start.exe**.

For Macintosh:
For full driver functionality, we recommend choosing the **CUPS driver** when adding a printer.

▶ Finished

Brother regularly updates firmware to add features and apply bug fixes. To check for the latest firmware, visit solutions.brother.com/up3.

Can't Connect? Check the following:

Wireless network

Restart your wireless access point/router (if possible).

Wired network

USB connection

Disconnect the cable.

Restart your machine and computer, and then go to **6**.

If still not successful, go to **7**.

If still not successful, visit support.brother.com for FAQs & Troubleshooting.

7 Alternative wireless setup

Find your SSID (Network Name) and Network Key (Password) on your wireless access point/router and write them in the table provided below.

SSID (Network Name)	
Network Key (Password)	

SSID: XXXXXXXX
Network key: XXXX

If you cannot find this information, ask your network administrator or wireless access point/router manufacturer.

■ For LCD models
To select each menu option, press ▲ or ▼, and then press **OK** to confirm. Select [Network] > [WLAN] > [Setup Wizard].

■ For Touchscreen models
Press **WiFi** > [Setup Wizard] > [Yes].

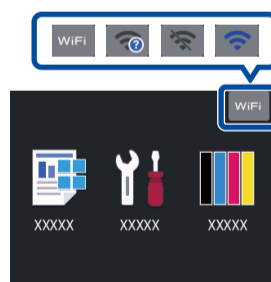

Even if you do not have a wireless access point/router, you can connect your device and your machine directly. For additional wireless network support, go to solutions.brother.com/wireless-support.

Select the SSID (Network Name) for your access point/router and enter the Network Key (Password).

When the wireless setup is successful, the Touchscreen/LCD displays [Connected].

If setup is not successful, restart your Brother machine and your wireless access point/router, and repeat **7**.

For Computer

Go to **6** to install software.

For Mobile Device

Go to **8** to install apps.

8 Print using your mobile device

Your mobile device must be connected to the same wireless network as your Brother machine.

Brother SupportCenter is a mobile app that provides the latest support information for your Brother product. Visit the App Store or Google Play™ to download.

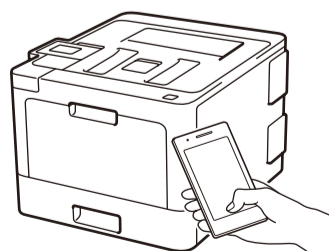

AirPrint is available for Apple device users. You do not need to download any software to use AirPrint. For more information, see the *Online User's Guide*.



Download and install our free application **Brother iPrint&Scan** from a mobile application store, such as the App Store, Google Play™ or Microsoft® Store using your mobile device.

Optional apps

You can print from your mobile device using various apps. For instructions, see the *Online User's Guide*.



Additional Wireless Support: solutions.brother.com/wireless-support

For FAQs, Troubleshooting, and to download software and manuals, visit support.brother.com.

© 2017 Brother Industries, Ltd. All rights reserved.

Free Manuals Download Website

<http://myh66.com>

<http://usermanuals.us>

<http://www.somanuals.com>

<http://www.4manuals.cc>

<http://www.manual-lib.com>

<http://www.404manual.com>

<http://www.luxmanual.com>

<http://aubethermostatmanual.com>

Golf course search by state

<http://golfingnear.com>

Email search by domain

<http://emailbydomain.com>

Auto manuals search

<http://auto.somanuals.com>

TV manuals search

<http://tv.somanuals.com>