

Ikelite Digital Housing

instruction manual

#6146.10 for Canon PowerShot G10

#6146.11 for Canon Powershot G11

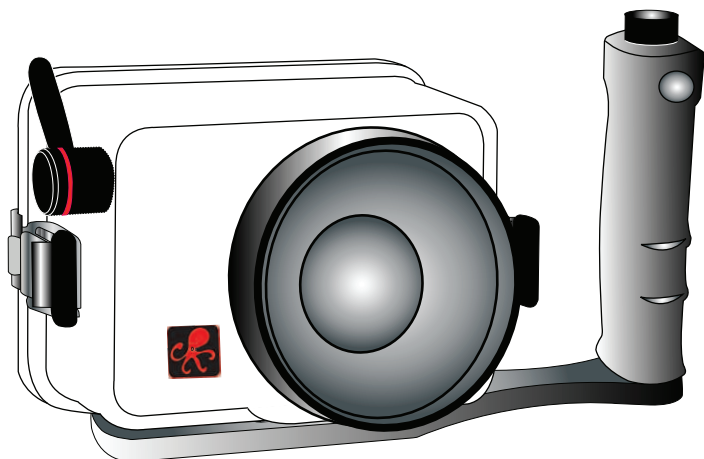

Congratulations on your purchase of an Ikelite Digital Camera Housing. Ikelite has over 45 years of experience in the underwater photographic and lighting market. Our products are designed and built in the USA by Ikelite for both the professional and amateur photographer.

The clear housing permits instant visual inspection of the camera and all sealing surfaces as well as complete monitoring of controls and camera LCD screens.

Ikelite Digital Housings are slightly negative in salt water for stability. This housing has been water pressure tested at the factory to 200' (60m).

Please Read

We suggest that you read this instruction booklet thoroughly before use. If you are new to underwater photography, be sure to read the General and Photo Tips sections.

We also suggest that you read your camera manual thoroughly to have a full understanding of each camera function.

Initial Camera Setup

1. Set ISO to 80.
2. Set camera mode dial to "Av" Aperture priority. In Aperture Priority mode "Av" the shutter speed should automatically go to 1/60 second.
3. Set Flash to "On" (lightning bolt in LCD).
4. For General photography, set aperture to f3.5.
5. For Macro photography, set aperture to f8.0.
6. Set White Balance (AWB) to "Auto".
7. Set Image Size to "L" and compression to "S" Superfine.
8. Set Metering to "Center-Weighted Avg."
9. In the camera menu set the "ND" Filter to "Cancel".

NOTES:

- TTL Flash NOT available when camera is in "M" Manual mode. There is no TTL flash even with Canon's own flash in the camera "M" mode. Manual power settings can be selected with the multi-control button on the back of the camera. The strobe should still be left in TTL to take advantage of this feature.
- Leave the housing hotshoe disconnected when using an EV manual controller. If using an EV controller in "M" Manual mode, set the EV controller to "non-Pre-flash".
- When multiple exposure (continuous shooting) mode is used, the external flash will not fire. This is normal and also happens with Canon external speedlights.

2

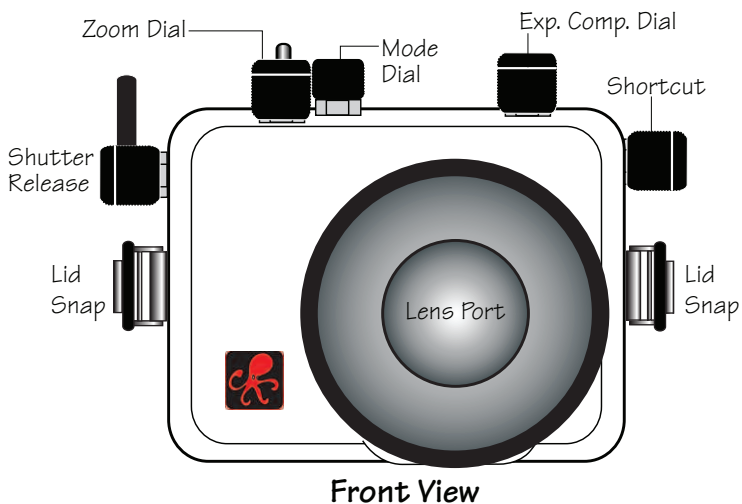

Front View

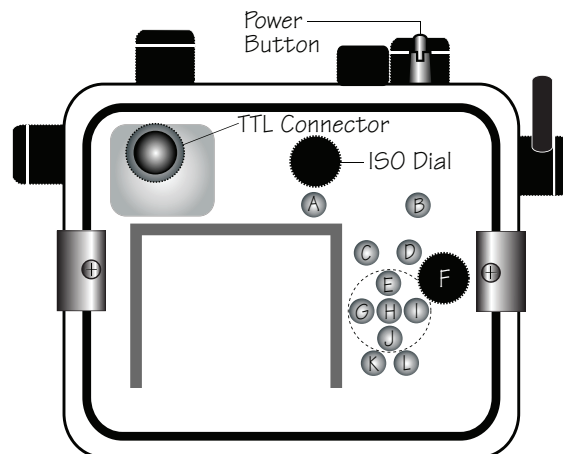

- | | | |
|--------------------|------------------|----------------|
| [A] Playback | [E] Manual Focus | [I] Flash |
| [B] AE/FE Lock | [F] Control Dial | [J] Self-Timer |
| [C] Single Erase | [G] Macro | [K] Display |
| [D] Metering Light | [H] FUNC./SET | [L] Menu |

Back View

Housing Lens Port and Accessory Lenses

Treat the glass in the lens port as a camera lens. After use, rinse and gently dry the lens port to avoid water spotting. To clean, use a mild soap solution or lens cleaner.

Do not use alcohol or window cleaner on the Lens Port.

See Page #19 for accessory lens information.

Opening the Housing

1. Lid Snaps have a Lock. To open, push Lid Snap Lock forward and lift as shown. Keep pressure on the Lid Snap so it does not fly open quickly.

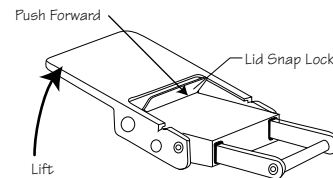

Some lid snaps have a lot of spring tension once they go over center, so keep a firm grip on the lid snap. Lid Snaps may be opened one at a time.

3

4

Installing the Camera

1. Pull out on each housing control until it stops. This will get the controls out of the way for installation of the camera.
2. Remove the back from the housing.
3. The mounting tray for the camera is secured to the housing back. Position the camera on the tray.
4. Slide the housing Hotshoe Connector into the Camera Hotshoe Mount (**Diagram A**). Slide the connector forward until it stops. This should be done before the camera is secured with the mounting bolt (**Page #6 - Diagram B**).

NOTE: If you are using an EV Controller and NOT hard-wiring your strobes directly to the housing, leave the housing hotshoe disconnected from the camera. You will also need to install the Flash Deflector (supplied) over the back of the housing port to block and deflect the camera flash to the EV controller.

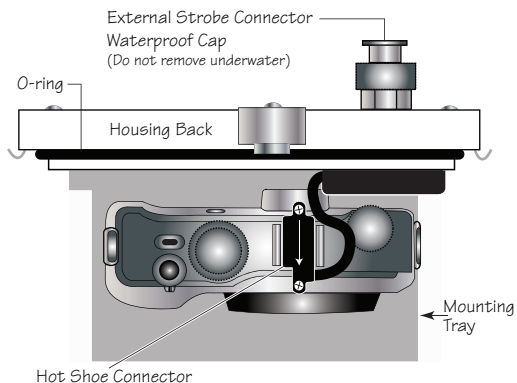

Diagram A

Caution:

Do not remove the External Strobe Connector Waterproof Cap unless an external sync cord is going to be plugged in. Do not remove the Waterproof Cap or Sync Cord underwater.

5

Installing the Camera (cont.)

5. Using a coin or screwdriver (preferred), secure the camera with the mounting bolt which threads into the camera's tripod socket (**Diagram B**).

CAUTION:

Some camera tripod socket threads are plastic. The mounting tray bolt is metal. Do not cross thread or over tighten as you may damage the camera tripod socket threads.

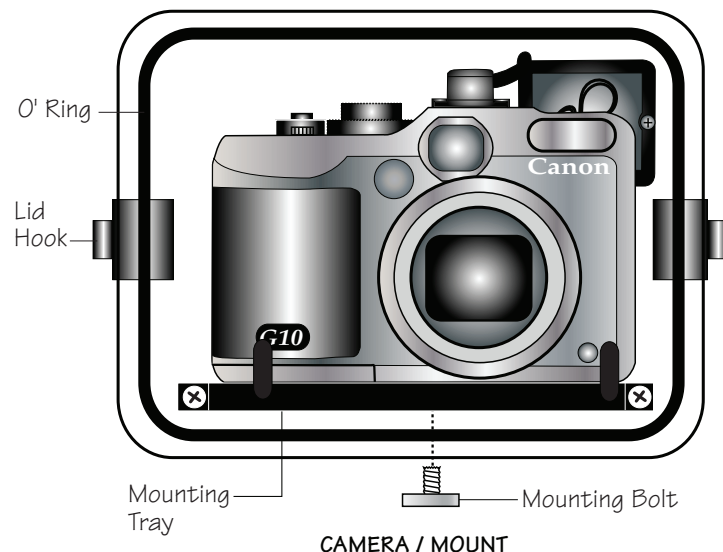

CAMERA / MOUNT

Diagram B

6

Closing the Housing

1. Place housing face down in your lap or on flat surface.
2. Check to see that there is an o-ring on the housing back and that it is clean and in its proper location.
3. Guide the back into the housing front. The o-ring should touch the housing all the way around. There should be an even gap all the way around between the housing and the housing back.
4. Lift the lid snaps so they are extended and place each lid snap into the corresponding hook on the housing back.
5. To close the housing, push down on the lid snaps until they snap into place. Lid snaps on opposite sides of the housing should be closed at the same time. Be sure they are down far enough to engage the lock.

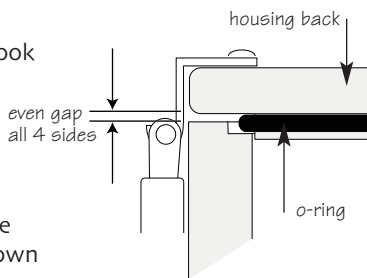
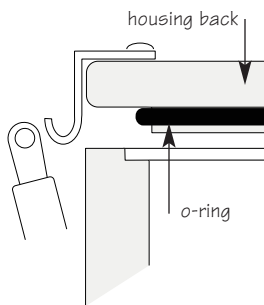

Double check - Once the housing is closed, check the o-ring seal.

Check the gap between the housing back and the housing. It should be even all the way around the housing. Look through the clear plastic back at the o-ring. You should see a darkened area where the o-ring is compressed against the housing back. If you do not see an even black compression seal all the way around the back, open the lid snaps, reset the housing back and close the lid snaps. Visually check the seal again.

7

Checking Controls

Once the housing has been closed, make sure the housing controls line up with the corresponding camera controls. If the housing controls are misaligned slightly, make sure the camera hold down bolt has been tightened down firmly so the camera is flat against the tray.

Turn Camera On

Turn the camera on and operate each of the housing controls to get a feel for using the camera in the housing. Take a few pictures above water with the camera in the housing.

Zoom Control

(NOTE:) After you have used the housing's zoom control, it must be returned to the center position to disengage. If the housing zoom control is pushing the zoom lever in either direction, you may not be able to take a picture or access any other function because the camera is receiving a signal from the engaged zoom control.

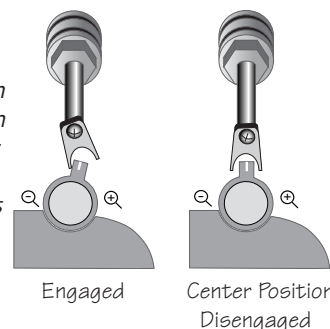

Flash Diffuser

A flash diffuser is included to improve image quality when using the camera's built-in flash to illuminate the subject. The camera flash is relatively weak for underwater use and is partially blocked by the housing port. Effective use is limited to macro photography at a distance of less than 2 feet (0.6m). Use of the built-in camera flash is not recommended for best results.

8

Flash Deflector

A flash deflector (supplied) can be installed over the back of the housing port next to the housing exterior. The deflector will deflect the camera flash when using an EV Manual Controller. The deflector will redirect the camera's flash to the EV Controller which controls the external strobe output. To attach, push the deflector over the back of the housing port, until the deflector clips into position, blocking the camera flash.

NOTE: The deflector is **not** needed when an Ikelite DS digital strobe is connected (hard-wired) directly to the housing (recommended).

Using External Strobes

For the best photographic results underwater, we recommend using Ikelite External Strobes. This housing has Conversion Circuitry built into the housing back, eliminating the need for an EV Controller. The Conversion Circuitry provides real Canon TTL flash when used with an Ikelite DS Digital substrobe(s) and the #4103.51 single or #4103.52 dual sync cord, connected directly to the housing.

See **page 13** for DS Substrobe compatibility with the Conversion Circuitry.

Using Non-Ikelite or Ikelite Non-DS Substrobes (Substrobe 50, 100A, 200, 400) with this Housing.

The Conversion Circuitry is automatically disabled when used with a Non-Ikelite or Non-DS Substrobe. These Substrobes can be used in their manual mode utilizing any power settings provided on the Substrobe.

9

Using Strobes (cont.)

DS161 (cont.)

The DS161 flash covers the equivalent of an 18mm lens or 100 degrees w/diffuser installed. It is the ideal choice when using wide angle lenses greater than 80 degrees. It also features a 1.5 second recycle time and 225 flashes per full charge.

SA-100 Ball/Socket Arm

The SA-100 system #4086.61 with its 1" diameter ball is ideal underwater. The #9571.3 extended stem mount allows easy attachment of the EV controller or flashlight mount, and drops right into the release handle. The arm system allows easy strobe placement from macro close-up to wide angle. The complete system removes with a push of the handle button.

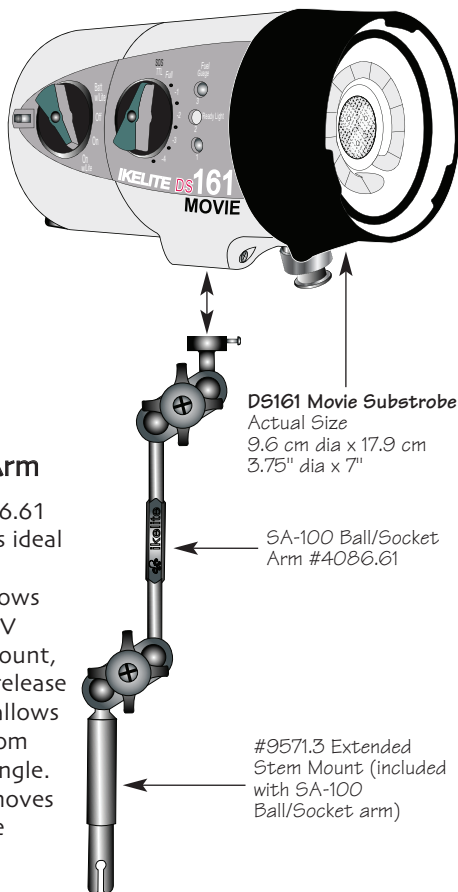

11

Using Ikelite DS Digital Strobes

For the best underwater photographic results, we recommend adding an external DS-digital strobe connected to the housing with a #4103.51 TTL Sync Cord and a SA-100 Ball/socket arm (**Page #11**).

Ikelite DS series Substrobes are industry favorites for their warm, even coverage and lightning fast recycle time. Being farther from the camera lens, the optional DS Substrobe aids in reducing the illumination of particles in the water and helps to eliminate backscatter. When used in conjunction with the EV-Controller, the DS51 Mode switch is set to the TTL setting and the EV-Controller provides ten power settings in half-stop increments.

Substrobe DS51

The Substrobe DS51 covers the equivalent of a 28mm lens. It is the ideal choice when using only the camera lens with no accessory wide angle lenses attached.

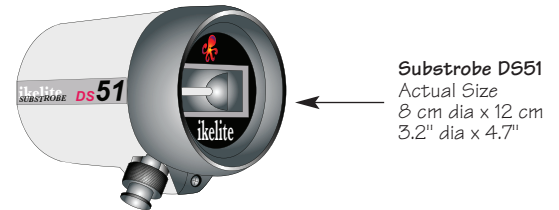

DS161 Movie Substrobe

The DS161 Movie Substrobe combines all of the functionality of our renowned DS160 with a powerful 500 lumen LED video light. Three super-bright LEDs are arranged behind a special optical element to provide 45 degrees angle of coverage free of hotspots.

10

Using Strobes (cont.)

Recommended Strobe Packages

DS51 Substrobe Package #3944.51 includes #4086.61 SA-100 Arm System with Ikelite TTL sync cord.

Add a second Substrobe DS51: #3944.52 includes #4086.61 SA-100 Arm System with Ikelite dual TTL sync cord.

DS160 Substrobe Package #3944.90 includes #4086.61 SA-100 Arm System and 1.5 hour Smart Charger with Ikelite TTL sync cord.

Add a second Substrobe DS160: #3944.92 includes #4086.61 SA-100 Arm System and Ikelite dual TTL sync cord.

DS161 Movie Substrobe Package #3945.01 (Recommended) includes #4086.61 SA-100 Arm System and 1.5 hour Smart Charger with Ikelite TTL sync cord.

Add a second DS161 Movie Substrobe: #3945.02 includes #4086.61 SA-100 Arm System and dual Ikelite TTL sync cord.

DS200 Substrobe Package #3944.60 includes #4085.26 Arm System and 1.5 hour Smart Charger with Ikelite TTL sync cord.

NOTE: #9523.32 Dual Tray required when using two strobes.

Please Read If Using an EV-Controller

TTL flash control is not available when using an EV-Controller, and therefore an EV Controller is not recommended for use with this housing.

NOTE: Do not attach the housing hotshoe to the camera when using the EV Manual Controller. If attached, the camera flash may not fire, which is necessary to trigger the external strobe.

Complete information regarding Ikelite products and optional accessories available at www.ikelite.com

12

NOTE: DS Substrobe Update information

DS50 Substrobes

- DS50 SubStrobes with a Serial Number below 63,850 can not be updated to operate with the Conversion Circuitry.
- DS50 SubStrobes with a Serial Number between 63,850 and 69,999 operate with the Conversion Circuitry, but require an update to provide optimum performance.
- DS50 Substrobes with a Serial Number of 70,000 or higher, or with one of the two following labels in the battery compartment provide optimum performance with the Conversion Circuitry and do not need an update.



DS125 Substrobes

- DS125 Substrobes with a Serial Number below 2,500 must be updated to operate correctly with the Conversion Circuitry.
- DS125 Substrobes with a Serial Number between 2,501 and 4,999 will operate with the Conversion Circuitry, but require an update to provide optimum performance.
- DS125 Substrobes with a Serial Number of 5,000 or higher, or with one of the two following labels in the battery compartment, provide optimum performance with the Conversion Circuitry and do not need an update.



To Update Your Substrobe:

Send to the Ikelite address on the back page of this manual or contact Ikelite for more information.

13

Lubricants

1. Ikelite provides silicone lubricant with the housing. We recommend you use only Ikelite lubricant on Ikelite products as some other brands may cause the o-ring to swell and not seal properly.
2. Use only enough lubricant to lightly cover control shafts and o-rings. Wipe off any excess lubricant with a clean cloth. Lubricant is not a sealant, it is used to reduce friction. Excessive lubricant can collect sand and dirt which may interfere with proper sealing.

CAUTION

Never use spray lubricants as the propellant ingredient can cause the plastic housing to crack.

Control Maintenance

Ikelite controls are designed to provide years of reliable service with minimal maintenance.

1. Push button controls require no maintenance other than rinsing in fresh water after saltwater use. If a push button control becomes difficult to push or if it sticks when depressed, soak the housing in luke warm fresh water. After a few minutes, operate the push button. If this does not correct the problem, return the housing to Ikelite for maintenance.
2. Some of the controls have long shafts. These controls can be pulled out, exposing the shaft (see diagrams A and B on pages #16 & #17). To lubricate the control, gently pull on the knob until the stainless steel shaft is exposed. Lightly lubricate the shaft, then move the shaft in and out several times. This will lubricate the x-ring in the Ikelite control gland. This should be done before using the housing after a prolonged storage period, or once a week when the housing is in constant use.

15

Maintenance

The Ikelite Digital Housing should be given the same care and attention as your other photographic equipment. In addition to normal maintenance, we recommend that the housing be returned to Ikelite periodically to be checked and pressure tested.

1. **Do Not** leave the camera and housing in direct sunlight for prolonged periods. Heat may damage the camera.
2. **Do Not** ship the camera in the housing.
3. Before using the housing, always check the tightness of the **set screw** in each control knob. Check each **control gland** penetrating the housing to make sure they are tight. There is a slight chance that either could vibrate loose during travel.
4. Keep the back o-ring clean and lightly lubricated. To lubricate, remove the o-ring from the back. Put a small amount of Ikelite lubricant on your fingers. Pull the o-ring through your fingers to apply a light coating of lubricant. Only apply enough lubricant to make the o-ring feel slick. **Do Not stretch the o-ring**. This light coating of lubricant will help to keep the o-ring from drying out and will help to show a dark sealing line when the housing back is properly sealed.
5. Keep the area where the o-ring fits and the sealing surface of the housing clean.
6. Rinse the housing exterior thoroughly in fresh water after each salt water use. Dry with a soft cloth. Dry lens port to eliminate water spotting. After several uses in salt water, soak the housing exterior in a mild soap solution, rinse and dry, before storing. When storing the housing, remove the back o-ring, lightly lubricate, and place in a plastic bag. Place the plastic bag with o-ring inside the housing for safe keeping.
7. If removing a housing push button, **Do Not** re-use the E-clip. Contact Ikelite for replacement E-clips (part #0319.12).

14

Control Maintenance Cont.

3. Some of the controls have a short shaft and cannot be pulled out exposing the shaft for lubrication. In the unlikely event one of these controls sticks or becomes difficult to operate you can remove the control from the housing and lubricate it, or return the housing to Ikelite for maintenance. To remove the control (Diagram A), loosen the set screw in the knob (allen wrench required); remove the knob. If there is salt or dirt build-up on the exposed control shaft, clean the shaft. Open the housing and gently slide the control shaft out of the control gland. Clean and lightly lubricate the shaft, including the end of the shaft. Slide the shaft back into the control gland and gently slide it back and forth a few times without fully removing the shaft from the gland. Replace the knob noting the flat area on the shaft. The set screw in the knob should tighten down against the flat area on the control, so the knob does not turn on the shaft.

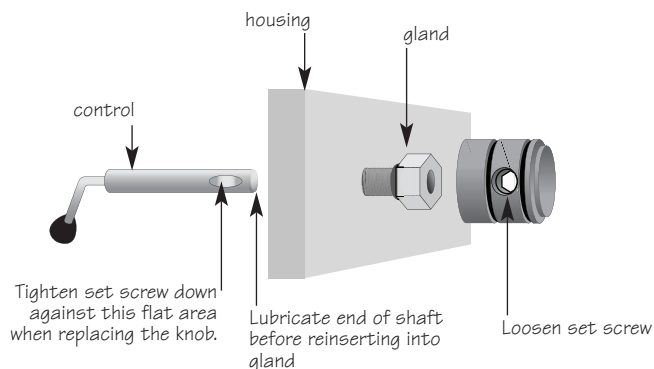
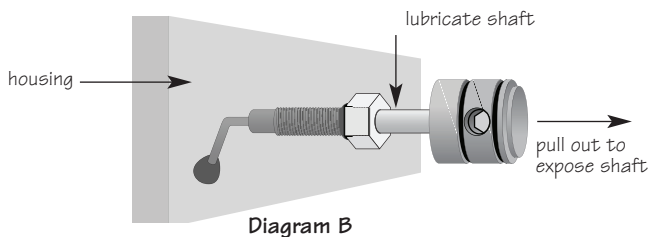

Diagram A

16



General Tips

1. Due to the power required to operate the camera, flash, and LCD screen, it is a good idea to start each dive with a fresh set of batteries.
2. Some cameras reset their flash to AUTO when the camera is turned on. If you prefer another setting be sure to select it.
3. As soon as you enter the water, take a moment and check the housing to see that it is properly sealed.
4. Next, check to see if there are any bubbles on the face of the lens port. If there are, take your finger and remove them. If there are bubbles on the lens port they can produce soft focus spots in your photographs.
5. If you are shooting with the camera's built-in flash and the camera lens is set to the widest angle, you may need to zoom the lens slightly or a shadow may appear in the lower left corner of close-up photographs. The lens port may block some of the light. Installing the flash diffuser will help to eliminate the shadow. (*You can test this above water*)

NOTE: To shoot photographs closer than 2 feet (0.6m), you should use an external strobe such as the DS51 or DS161. With an external strobe, you can position it so nothing blocks the light path between the strobe and the subject.

17

Photo Tips

1. The number one rule in underwater photography is eliminate as much water between camera and subject as possible. Get as close as you can to the subject, then use the zoom. If you are using flash, subjects beyond 6 feet (1.8m) will not have much color.
2. The camera's built-in flash is very close to the camera lens. The flash can light up any suspended particles in the water and they can be recorded in your picture. This effect is called backscatter. To eliminate as much backscatter as possible, photograph close. Photograph in clear water; do not stir up the sand or silty bottom. If backscatter becomes a problem in the environment you are photographing, an external flash will help eliminate much of the backscatter.
3. Many digital cameras have a slight lag time between when you press the shutter release button and the camera actually takes the picture. Hold the camera steady a second or two after pressing the shutter release button.
4. Do not shoot down on subjects as they will quite often blend into the background and be difficult to see in the photograph. Shoot subjects straight on or shoot up at a slight angle using the blue water as a contrasting background.
5. Underwater flash is used to restore the warmer colors filtered out by the water as well as to illuminate the subject. When photographing underwater, set the camera to use flash on every shot. If the camera's flash is set to AUTO and the sun is behind your subject, the camera may see enough light and not fire the flash. With the sun behind the subject, the subject is shaded (dark) and needs flash for a good exposure.
6. When using daylight or flash, if your camera consistently over or underexposes the image, you may want to adjust your camera's exposure compensation settings.

18

Photo Tips Cont.

7. Image manipulation programs can often correct underexposed images. Overexposed images result in missing color information which cannot be corrected. If exposure error occurs, it is better to have the image slightly underexposed.

Optional Accessories

Back o-ring #0110

Carry a spare o-ring in case the original becomes damaged or lost.

Tray with Dual Release Handles #9523.32

Required to mount two external Substrobes.

WD-4 Wide-Angle Conversion Dome #6430.4

The removeable WD-4 corrects light refraction underwater, restoring the camera's original 28mm angle of coverage. Approximately 3/4 of the camera's zoom range can be used with the dome in place. Additional information is linked from the G10 web page at www.ikelite.com.

External Macro Adaptor #9306.82

Allows attachment of 67mm threaded macro lenses from Inon and Epoque. NOT for use with 67mm threaded wide-angle lenses.

NOTE: Other Accessory and Wide-Angle Conversion lenses cannot be used with this housing.

Ikelite Limited Warranty

All Ikelite products are warranted against any manufacturing defects for a period of one year from the original date of purchase. Defective products should be returned prepaid to Ikelite. Ikelite will, at its discretion, repair or replace such products, and will return to customer prepaid. All other claims of any nature are not covered. Housing is pressure tested and warranted to 200' (60m) maximum underwater depth. Except as mentioned above, no other warranty expressed or implied, applies to this Ikelite product.

19

Returning Products for Service

Ikelite is most interested in performing any service to ensure that all products perform as intended. Evidence of purchase date must be provided to obtain warranty service.

No prior authorization is required. You may return directly to us or through your dealer. Please include a brief description of the problem, any relevant e-mail correspondence, and/or instructions on what you want us to do. Always include name, shipping address, e-mail address, and phone number inside of the package. You may also want to insure the package. No reimbursements for return freight will be issued. Send Postage Pre-Paid to:

Ikelite Underwater Systems
ATTN: Repair Dept.
50 West 33 Street
Indianapolis, IN 46208 USA

Returning Products for Service (outside the United States)

For the separate international customs documentation form that you complete to accompany the shipment, please state or designate that the enclosed products were originally manufactured in the USA and are being returned to the manufacturer for repair service. Value of the equipment listed for customs purposes should be zero.

How to contact Ikelite if necessary

E-mail: ikelite@ikelite.com
Phone 317.923.4523
Fax 317.924.7988



Ikelite Underwater Systems
50 West 33rd Street
Indianapolis, IN 46208 USA

Digital 6146.10_6146.11-03-0810

Free Manuals Download Website

<http://myh66.com>

<http://usermanuals.us>

<http://www.somanuals.com>

<http://www.4manuals.cc>

<http://www.manual-lib.com>

<http://www.404manual.com>

<http://www.luxmanual.com>

<http://aubethermostatmanual.com>

Golf course search by state

<http://golfingnear.com>

Email search by domain

<http://emailbydomain.com>

Auto manuals search

<http://auto.somanuals.com>

TV manuals search

<http://tv.somanuals.com>